

Operation and Installation

RV/Mobile Generator Sets



Models:

15/20CCO

15/20CCFO

15/20CCOZ

15/20CCFOZ

ISO 9001
KOHLER
GENERATORS
INTERNATIONALLY REGISTERED

KOHLER[®]
POWER SYSTEMS

TP-5605 4/97a

California Proposition 65

 WARNING

Engine exhaust from this product contains chemicals known to the State of California to cause cancer, birth defects, or other reproductive harm.

Table of Contents

SUBJECT	PAGE	SUBJECT	PAGE
Safety Precautions and Instructions	I	Cleaning	3-13
Introduction	i	Checking Electrolyte Level	3-14
Service Assistance	i	Checking Specific Gravity	3-14
Routine Service Parts	ii	Gauge Connections for Single-Phase Models ..	3-15
Section 1. Specifications	1-1	Wattage Requirements	3-16
Introduction	1-1	Generator Service	3-17
General Specifications	1-1	General	3-17
Engine	1-2	Storage Procedure	3-17
Generator	1-3	Section 4. Troubleshooting	4-1
Generator Models 15/20 kW	1-4	Engine	4-1
Section 2. Operation	2-1	Electrical System	4-4
Prestart Checklist	2-1	Generator	4-4
Exercising the Generator	2-1	Section 5. Wiring Diagrams	5-1
Controller (Single-Phase)	2-2	Voltage Reconnection	5-1
Controller (Three-Phase)	2-3	Voltage Reconnection Procedure	5-2
Preheat Feature	2-4	12-Lead (Three-Phase) Generator Sets	5-3
Starting Procedure	2-4	Section 6. Installation	6-1
Stopping Procedure	2-4	Introduction	6-1
Fault Shutdowns	2-4	Features	6-1
Low Oil Pressure		Generator Selection And	
Shutdown Switch	2-4	Wattage Requirements	6-2
High Water Temperature		Installation Factors	6-2
Shutdown Switch	2-5	Electrical Load	6-2
Circuit Protection	2-5	Lighting Load	6-2
Section 3. Scheduled Maintenance	3-1	Motor Loads	6-3
General	3-1	Appliance Loads	6-4
Lubrication System	3-3	Kilowatt Derating	6-4
Oil Selection	3-3	Compartment Size	6-4
Oil Check	3-3	Air Requirements	6-6
Oil Change	3-4	Remote Radiator Cooling System	6-9
Oil Filter	3-5	Fuel System	6-13
Fuel System	3-6	Fuel Lines	6-14
Specification	3-6	Exhaust Systems	6-15
Fuel Filter	3-6	Electrical Systems	6-17
Bleeding the Fuel System	3-7	Battery And Connections	6-17
Fuel Solenoid	3-8	AC Load Lead Connections	6-19
Air Cleaner Service	3-8	Remote Switch Connection	
Governor	3-9	(Single-Phase Models Only)	6-20
Cooling System	3-10	Section 7. Installation Drawings	7-1
Belt Tension	3-12	Appendix A. Glossary of Abbreviations	A-1
Battery Charging	3-12	Appendix B. Operating Hour Service Log ..	B-1
Battery	3-13		

Safety Precautions and Instructions

A generator set, like any other electromechanical device, can pose potential dangers to life and limb if improperly maintained or operated. The best way to prevent accidents is to be aware of potential dangers and act safely. Please read and follow the safety precautions and instructions below to prevent harm to yourself and others. This manual contains several types of safety precautions and instructions which are explained below. **SAVE THESE INSTRUCTIONS.**

DANGER

Danger indicates the presence of a hazard that *will* cause *severe* personal injury, death, or substantial property damage.

WARNING

Warning indicates the presence of a hazard that *can* cause *severe* personal injury, death, or substantial property damage.

CAUTION

Caution indicates the presence of a hazard that *will* or *can* cause *minor* personal injury or property damage.

NOTICE

Notice communicates installation, operation, or maintenance information that is important but not hazard related.

Safety decals affixed to the generator set in prominent places advise the operator or service technician of potential hazards and how to act safely. The decals are reproduced in this publication to improve operator recognition. Replace missing or damaged decals.

Accidental Starting



Accidental starting.
Can cause severe injury or death.

Disconnect battery cables before working on generator set (disconnect negative lead first and reconnect it last).

Disabling generator set. Accidental starting can cause severe injury or death. Disconnect battery cables (remove negative lead first and reconnect it last) to disable generator set before working on the generator set or connected equipment. The generator set can be started by the remote start/stop switch unless this precaution is followed.

Battery

WARNING



Sulfuric acid in batteries.
Can cause severe injury or death.

Use protective goggles and clothes. Battery acid can cause permanent damage to eyes, burn skin, and eat holes in clothing.

Battery acid. Sulfuric acid in batteries can cause severe injury or death. Sulfuric acid in battery can cause permanent damage to eyes, burn skin, and eat holes in clothing. Always wear splash-proof safety goggles when working near the battery. If battery acid is splashed in the eyes or on skin, immediately flush the affected area for 15 minutes with large quantities of clean water. Seek immediate medical aid in the case of eye contact. Never add acid to a battery after placing the battery in service, as this may result in hazardous spattering of battery acid.

Battery gases. Explosion can cause severe injury or death. Battery gases can cause an explosion. Do not smoke or permit flame or spark to occur near a battery at any time, particularly when it is charging. Avoid touching terminals with tools, etc., to prevent burns and sparks that could cause an explosion. Remove wristwatch, rings, and any other jewelry before handling battery. Never connect negative (-) battery cable to positive (+) connection terminal of starter solenoid. Do not test battery condition by shorting terminals together. Sparks could ignite battery gases or fuel vapors. Ventilate any compartment containing batteries to prevent accumulation of explosive gases. To avoid sparks, do not disturb battery charger connections while battery is being charged. Always turn battery charger off before disconnecting battery connections. Remove negative lead first and reconnect it last when disconnecting battery.

Engine Backfire/Flash Fire

⚠ WARNING

<p>Fire. Can cause severe injury or death.</p> <p>Do not smoke or permit flame or spark to occur near fuel or fuel system.</p>

Servicing fuel system. A flash fire can cause severe injury or death. Do not smoke or permit flame or spark to occur near carburetor, fuel line, fuel filter, fuel pump, or other potential sources of spilled fuel or fuel vapors. Catch all fuel in a suitable container when removing fuel line or carburetor.

Servicing air cleaner. A sudden backfire can cause severe injury or death. Do not operate with air cleaner removed.

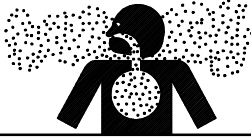
Exhaust System

⚠ WARNING

<p>Carbon monoxide. Can cause severe nausea, fainting, or death.</p> <p>The exhaust system must be leakproof and routinely inspected.</p>

Generator set operation. Carbon monoxide can cause severe nausea, fainting, or death. Never operate the generator set inside a building unless the exhaust gas is piped safely outside. Never operate in any area where exhaust gas could accumulate and seep back inside a potentially occupied building or vehicle. Be careful when parking your vehicle to avoid obstructing the exhaust outlet. The exhaust gases must discharge freely to prevent carbon monoxide from deflecting into the vehicle. Avoid breathing exhaust fumes when working on or near the generator set. Carbon monoxide is particularly dangerous because it is an odorless, colorless, tasteless, nonirritating gas that can cause death if inhaled for even a short period of time.

Carbon monoxide symptoms. Carbon monoxide can cause severe nausea, fainting, or death. Carbon monoxide is a poisonous gas which is present in exhaust gases. Carbon monoxide poisoning symptoms include but are not limited to the following:

- Light-headedness, dizziness
- Physical fatigue, weakness in joints and muscles
- Sleepiness, mental fatigue, inability to concentrate or speak clearly, blurred vision
- Stomachache, vomiting, nausea

If experiencing any of these symptoms and carbon monoxide poisoning is possible, affected persons should seek fresh air immediately. They should remain active. They should not sit, lie down, or fall asleep. Alert others to the possibility of carbon monoxide poisoning. If the condition of affected persons does not improve within minutes of breathing fresh air, they should seek medical attention.

Copper tubing exhaust systems. Carbon monoxide can cause severe nausea, fainting, or death. Do not use copper tubing in diesel exhaust systems. Sulfur in diesel exhaust causes rapid deterioration of copper tubing exhaust systems resulting in exhaust leakage.

Installing exhaust tail pipe. Carbon monoxide can cause severe nausea, fainting, or death. Install exhaust system tail pipe so discharged exhaust gases will not be drawn into vehicle interior through windows, doors, air conditioners, etc. Do not use flexible tail piping because it could crack and allow lethal exhaust fumes to enter the vehicle.

Inspecting exhaust system. Carbon monoxide can cause severe nausea, fainting, or death. In addition to routine exhaust system inspection, install a carbon monoxide detector. Consult your coach builder or dealer for approved detector installation. Inspect your detector before each generator set use.

Fuel System

WARNING



Explosive fuel vapors.
Can cause severe injury or death.

Use extreme care when handling, storing, and using fuels.

Fuel system. Explosive fuel vapors can cause severe injury or death. All fuels are highly explosive in a vapor state. Use extreme care when handling and storing fuels. Store fuel in a well-ventilated area away from spark-producing equipment and out of the reach of children. Never add fuel to the tank while the engine is running since spilled fuel may ignite on contact with hot parts or from ignition spark. Do not smoke or permit flame or spark to occur near sources of spilled fuel or fuel vapors. Keep fuel lines and connections tight and in good condition. Do not replace flexible fuel lines with rigid lines. Use flexible sections to avoid breakage caused by vibration. Do not operate generator set in the presence of fuel leaks, fuel accumulation, or sparks. Repair systems before resuming generator set operation

Draining fuel system. Explosive fuel vapors can cause severe injury or death. Spilled fuel can cause an explosion. Use a container to catch fuel when draining fuel system. Wipe up all spilled fuel after draining system.

Hazardous Noise

CAUTION



Hazardous noise.
Can cause loss of hearing.

Never operate generator set without a muffler or with a faulty exhaust system.

Hazardous Voltage/ Electrical Shock

WARNING



Hazardous voltage.



Moving rotor.

Can cause severe injury or death.

Operate generator set only with all guards and electrical enclosures in place.

WARNING



Hazardous voltage.
Backfeed to utility system can cause severe injury, death, or property damage.

Connect generator set to building electrical system only through an approved device and after building main switch is open.

Grounding generator set. Hazardous voltage can cause severe injury or death. Electrocutation is possible whenever electricity is present. Open main circuit breakers of all power sources before servicing equipment. Configure the installation to electrically ground the generator set and electrical circuits when in use. Never contact electrical leads or appliances when standing in water or on wet ground, as the chance of electrocution is increased under such conditions.

Short circuits. Hazardous voltage can cause severe injury or death. Short circuits can cause bodily injury and/or equipment damage. Do not contact electrical connections with tools or jewelry while adjustments are made. Remove wristwatch, rings, and jewelry before servicing equipment.

Engine block heater. Hazardous voltage can cause severe injury or death. Engine block heater can cause electrical shock. Remove engine block heater plug from electrical outlet before working on block heater electrical connections.

Electrical backfeed to utility. Hazardous backfeed voltage can cause severe injury or death. Connect generator set to building/campground electrical system only through an approved device and after building/campground main switch is open. Backfeed connections can cause serious injury or death to utility personnel working on power lines and/or personnel in the vicinity of the work area. Unauthorized connection to utility electrical system may be unlawful in some states and/or localities. Install a transfer switch to prevent interconnection of generator set power and other sources of power.

Heavy Equipment

⚠ WARNING

<p>Unbalanced weight. Improper lift can cause severe injury or death and/or equipment damage.</p> <p>Do not use lifting eyes. Use slings under skid to balance and lift generator set.</p>

Hot Parts

⚠ WARNING

<p>Hot coolant and steam. Can cause severe injury or death.</p> <p>Before removing pressure cap, stop generator set and allow it to cool. Then loosen pressure cap to relieve pressure.</p>

⚠ WARNING

<p>Hot engine and exhaust system. Can cause severe injury or death.</p> <p>Do not work on generator set until it is allowed to cool.</p>



Checking coolant level. Hot coolant can cause severe injury or death. Allow engine to cool. Release pressure from cooling system before opening pressure cap. To release pressure, cover the pressure cap with a thick cloth; then slowly turn it counterclockwise to the first stop. Remove cap after pressure has been completely released and the engine has cooled. Check coolant level at tank if generator set is equipped with a coolant recovery tank.

Servicing exhaust system. Hot parts can cause severe injury or death. Do not touch hot engine parts. An engine becomes hot while running and exhaust system components become extremely hot.

Combustible materials. Fire can cause severe injury or death. Hot exhaust system can ignite adjacent combustible materials. Do not locate electrical wiring, fuel lines, or combustible material above the exhaust muffler. Exercise caution when parking your vehicle to prevent exhaust system and hot exhaust gases from starting grass fires.

Combustible materials. Fire can cause severe injury or death. Hot generator set can ignite debris in compartment. Keep the compartment and generator set clean and free of debris and combustible materials to minimize possibility of fire. Do not block fuel/oil drain opening in generator set mounting tray. Cut a corresponding hole in the subfloor for drain opening if subfloor is used.

Moving Parts

⚠ WARNING	
	
Hazardous voltage.	Moving rotor.
Can cause severe injury or death.	
Operate generator set only with all guards and electrical enclosures in place.	

⚠ WARNING	
	
Rotating parts.	
Can cause severe injury or death.	
Do not operate generator set without all guards, screens, and covers in place.	

Tightening hardware. Flying projectiles can cause severe injury or death. Retorque all crankshaft and rotor hardware after servicing. Do not loosen crankshaft hardware or rotor throbolt when making adjustments or servicing generator set. Rotate crankshaft manually in a clockwise direction only. Turning crankshaft bolt or rotor throbolt counterclockwise can loosen hardware. Loose hardware can cause hardware or pulley to release from engine of generator set and can cause personal injury.

Servicing generator set when operating. Exposed moving parts can cause severe injury or death. Keep hands, feet, hair, clothing, and test leads away from belts and pulleys when generator set is running. Replace guards, screens, and covers before operating generator set.

Notice

NOTICE	
This generator set has been rewired from its nameplate voltage to:	
<div style="border: 1px solid black; height: 40px; width: 100%;"></div>	
246242	

NOTICE

Voltage reconnection! Affix notice to generator set after reconnecting to a voltage different than the nameplate. Order voltage reconnection decal 246242 from authorized service distributors/dealers.

NOTICE

Hardware damage! Engine and generator set may use both American Standard and metric hardware. Use the correct size tools to prevent rounding of bolt heads and nuts.

NOTICE

When replacing hardware, do not substitute with inferior grade hardware. Screws and nuts are available in different hardness ratings. American Standard hardware uses a series of markings and metric hardware uses a numeric system to indicate hardness. Check markings on bolt head and nuts for identification.

NOTICE

Canadian installations only:

For standby service connect output of generator set to a suitably rated transfer switch in accordance with Canadian Electrical Code, Part 1.

NOTICE

This generator set does not comply with United States Coast Guard (U.S.C.G.) requirements and must not be used for marine applications. Use only generator sets specified for marine use in marine installations. U.S.C.G. Regulation 33CFR183 requires a generator set to be ignition protected when used in a gasoline-fueled environment.

Notes

Introduction

All information in this publication represents data available at time of printing. Kohler Co. reserves the right to change this literature and the products represented without incurring obligation.

Read through this manual and carefully follow all procedures and safety precautions to ensure proper equipment operation and to avoid bodily injury. Read and follow the Safety Precautions and Instructions section at the beginning of this manual. Keep this

manual with equipment for future reference.

Equipment service requirements are minimal but are very important to safe and efficient operation; therefore, inspect parts often and perform required service at the prescribed intervals. An authorized service distributor/dealer should perform required service to keep equipment in top condition.

Service Assistance

For sales and service in the U.S.A. and Canada check the yellow pages of the telephone directory under the heading GENERATORS– ELECTRIC for an authorized service distributor/dealer or call 1-800-544-2444.

For sales and service outside the U.S.A. and Canada, contact your local distributor.

For further information or questions, contact the company directly at the following address or number:

KOHLER CO., Kohler, Wisconsin 53044 U.S.A.
Phone: 414-565-3381
Fax: 414-459-1646 (U.S.A. Sales)
414-459-1614 (International)

To ensure supply of correct parts or information, make note of the following identification numbers in the spaces provided:

GENERATOR SET

MODEL, SPEC, and SERIAL numbers are found on the nameplate attached to the generator set.

Model No. _____

Specification No. _____

Serial No. _____

GENERATOR SET ACCESSORIES

An alternate nameplate inside the junction box identifies factory-installed generator set accessories.

Accessory Nos. _____

ENGINE

The engine serial number is found on the engine nameplate.

Engine Serial No. _____

Routine Service Parts

Kohler generator distributor/dealers have a complete listing of parts for each generator set. Contact the local Kohler generator distributor/dealer for service.

Part Description	Kohler Part No.
Air cleaner element	258646
Oil filter	229841
Fuel filter	225010
Alternator V-belt	225626
Black spray paint	221292

Section 1. Specifications

Introduction

Your vehicle is equipped with a dependable Kohler alternating-current RV/Mobile Generator Set. Service requirements of the generator set are minimal, but it is important that the required services be performed at the prescribed intervals. Please take a few moments to read through this manual; then carefully follow all service recommendations to keep your set in top condition. In the space provided, record the MODEL, SPECIFICATION, SERIAL and ENGINE SPEC. numbers as found on the nameplate attached to the belt

guard of the engine for remote-radiator models and on the radiator bracket for in-line radiator models (see Section 8 "Service Ordering Instructions"). This information will enable your Kohler Generator Service Dealer/Distributor to supply the correct part or data for your particular version. Keep this manual in your vehicle for future reference. The illustrations in this manual are representative of most units. Your generator set may differ slightly from those shown.

General Specifications

	15 kW (60Hz)	20 kW (60Hz)		
Dimensions L x W x H in. (mm):				
Remote Radiator (Single Phase)	39.57 x 20.89 x 25.61 (1005 x 531 x 650)	39.57 x 20.89 x 27.25 (1005 x 531 x 692)		
Remote Radiator (Single Phase) Airbag Mounted.	39.57 x 22.00 x 25.61 (1005 x 559 x 650)	39.57 x 22.00 x 28.51 (1005 x 559 x 724)		
In-line Radiator (Single Phase)	45.02 x 20.99 x 28.00 (1144 x 533 x 711)	45.02 x 20.99 x 28.00 (1144 x 533 x 711)		
In-line Radiator (Three Phase)	46.62 x 20.99 x 28.00 (1184 x 533 x 711)	46.62 x 20.99 x 28.00 (1184 x 533 x 711)		
Weight— dry, lbs. (kg):				
Remote Radiator (Single Phase)	684 (310)	695 (315)		
Remote Radiator (Single Phase) Airbag Mounted.	N/A	N/A		
In-line Radiator (Single Phase)	719 (326)	730 (331)		
In-line Radiator (Three Phase)	719 (326)	730 (331)		
Air Requirements CFM (M ³ /min):				
Combustion.	70 (2)	70 (2)		
Cooling	1930 (55)	1930 (55)		
Fuel Inlet Size in. (mm)	1/4-18 N.P.S.F	1/4-18 N.P.S.F		
Fuel Return Size in. (mm)	1/4-18 N.P.S.F	1/4-18 N.P.S.F		
Fuel Consumption gph (Lph):				
Load	25%	50%	75%	100%
15 kW	0.6 (2.3)	0.8 (3.0)	1.1 (4.2)	1.4 (5.3)
20 kW	0.9 (3.4)	1.2 (4.5)	1.5 (5.7)	1.9 (7.2)

DERATION: All units are rated 1.0 power factor. The kilowatts of the generator set will decrease 3.5% for each 1,000 feet (305 meters) above 500 feet (152 meters) above sea level and 1% for each 10°F (5.5°C) above 85°F (30°C).

Engine

Some general engine specifications are listed below.
Refer to the appropriate service section and the engine
service manual for specific service details.

	15 kW	20 kW
Manufacturer	Yanmar	
Model	4TN84E-RK	4TN84TE-TK
Type	Water-cooled, 4-cycle diesel engine	
Number Cylinders	4	
Firing Order	1-3-4-2	1-3-4-2
Compression Ratio	17.79:1	16.99:1
Displacement cu. in. (cm ³)	116 (1910)	
Rated Horsepower (60 Hz)	27.4	36.3
RPM (60 Hz)	1800	
Bore in. (mm)	3.307 (84)	
Stroke in. (mm)	3.386 (86)	
Combustion System	Direct Injection	
Valve Clearance in. (mm)		
Intake	0.0079 (0.2)	
Exhaust	0.0079 (0.2)	
Cylinder Block Material	Cast Iron	
Cylinder Head Tightening Torque ft. lbs (Nm)		
Step 1:	25.23–31.1 (3.5–4.3)	
Step 2:	54.23–61.46 (7.5–8.5)	
Cylinder Head Material	Cast Iron	
Connecting Rod	Forged Carbon Steel	
Piston Rings	2 Compression/1 Oil	
Main Bearings, Number and Type	4, Replaceable Sleeves	
Governor	Mechanical	
Lubrication System	Full Pressure	
Oil Capacity (with filter) qts. (L)	6.1 (5.8)	
Oil Type (API)	CC or CD	
Oil Pressure psi (kPa)	42.66–56.88 (294–392)	
Fuel Recommendation	Diesel– ASTM D975 No. 2-D (Cetane No. > 45)	
Aspiration	Natural Aspiration	Turbocharged
Fuel Injection Pump	Yanmar YPES	
Battery Voltage	12	
Battery Ground	Negative	
Battery Recommendation (min.)	625 Cold Cranking Amps 100 Amp Hr.	
Starter Motor	Bendix Automotive Type	
Cooling System Capacity qts. (L)		
Remote Radiator (Engine Water Jacket)	2.85 (2.7)	
In-line Radiator	4 qts. 16 oz. (4.26)	
Timing	16° ±1°	
Air Cleaner	Dry Paper Element	

Generator

Models 15CCO/CCFO/CCOZ/CCFOZ

Model Series	Voltage		Wire	Amps/			PH
	Code	Voltage		Pole	kW		
60 Hz Models:							
15CCO	61	120/240	3	62.5	15.0	1	
15CCO	101	100/200	3	75.0	15.0	1	
15CCOZ	01	120/240	4	45.1	15.0	3	
15CCOZ	51	139/240	4	45.1	15.0	3	
15CCOZ	51	127/220	4	49.2	15.0	3	
15CCOZ	71	227/480	4	22.6	15.0	3	
15CCOZ	71	240/416	4	26.0	15.0	3	
15CCOZ	81	120/208	4	52.0	15.0	3	

50 Hz Models:

15CCFO	101	120/240	3	52.1	12.5	1	
15CCFO	61	110/220	3	56.8	12.5	1	
15CCFO	11	100/200	3	62.5	12.5	1	
15CCFO	41	220	2	56.8	12.5	1	
15CCFOZ	51	110/190	4	47.5	12.5	3	
15CCFOZ	51	115/200	4	45.1	12.5	3	
15CCFOZ	71	220/380	4	23.7	12.5	3	
15CCFOZ	71	230/400	4	22.6	12.5	3	
15CCFOZ	71	240/416	4	21.7	12.5	3	
15CCFOZ	81	120/208	4	43.4	12.5	3	
15CCFOZ	81	110/220	4	41.0	12.5	3	

Models 20CCO/CCFO/CCOZ/CCFOZ

Model Series	Voltage		Wire	Amps/			PH
	Code	Voltage		Pole	kW		
60 Hz Models:							
20CCO	61	120/240	3	83.3	20.0	1	
20CCO	101	100/200	3	100.0	20.0	1	
20CCOZ	01	120/240	4	60.1	20.0	3	
20CCOZ	51	139/240	4	60.1	20.0	3	
20CCOZ	51	127/220	4	65.6	20.0	3	
20CCOZ	71	227/480	4	30.1	20.0	3	
20CCOZ	71	240/416	4	34.7	20.0	3	
20CCOZ	81	120/208	4	69.4	20.0	3	

50 Hz Models:

20CCFO	101	120/240	3	69.4	16.5	1	
20CCFO	61	110/220	3	75.8	16.5	1	
20CCFO	11	100/200	3	83.3	16.5	1	
20CCFO	41	220	2	75.8	16.5	1	
20CCFOZ	51	110/190	4	63.3	16.5	3	
20CCFOZ	51	115/200	4	60.1	16.5	3	
20CCFOZ	71	220/380	4	31.7	16.5	3	
20CCFOZ	71	230/400	4	30.1	16.5	3	
20CCFOZ	71	240/416	4	28.9	16.5	3	
20CCFOZ	81	120/208	4	57.8	16.5	3	
20CCFOZ	81	110/220	4	54.7	16.5	3	

Generator Models 15/20 kW

	Single-Phase Models	Three-Phase Models
RPM (60-Hz Models)	1800	1800
RPM (50-Hz Models)	1500	1500

15 kW:

Stator Resistance (ohms)** Leads:

1-2, 3-4, 33-44	0.07	N/A
55-33	1.3	N/A
B1-B2	0.06	N/A
Rotor Resistance (ohms)	3.0	N/A

20 kW:

Stator Resistance (ohms)** Leads:

1-2, 3-4, 33-44	0.07	N/A
55-33	1.3	N/A
B1-B2	0.06	N/A
Rotor Resistance (ohms)	3.0	N/A

Excitation Method	Static Excited	Rotating Exciter
Overbolt Torque	25 ft. lbs. (300 in. lbs.)	
Voltage Regulator Type	PowerBoostä III E	PowerBoostä V
Insulation (Rotor and Stator)	Class 155, Epoxy Varnish, Vacuum Impregnated	
Winding Material	Copper	
Bearing (Number and Type)	1, Replaceable Ball	
Circuit Protection:		
Controller	10-Amp Fuse	10-Amp Circuit Breaker
Optional AC Output	Manual-Reset Circuit Breaker	
Voltage Regulator	10-Amp Fuse	N/A
Fuel Solenoid	10-Amp Fuse	

** Most ohmmeters will not give accurate readings when measuring less than 1 ohm. The stator can be considered good if a low resistance reading (continuity) is obtained and there is no evidence of shorted windings (discoloration). Do not confuse a low resistance reading with a reading indicating a shorted winding.

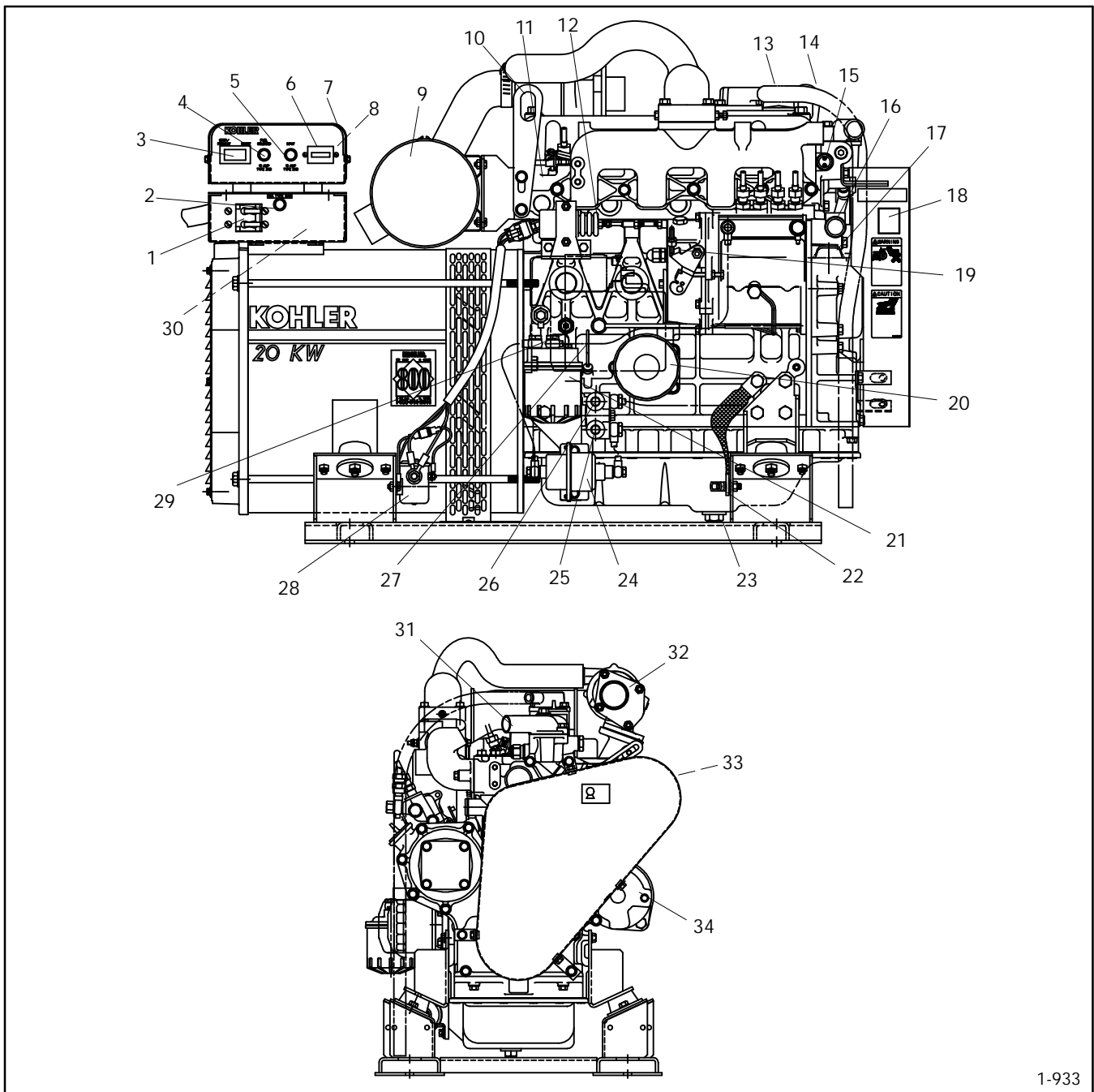

1-933

- | | |
|--|--|
| 1. Optional AC circuit breaker | 19. Mechanical governor |
| 2. Voltage regulator fuse | 20. Oil filter |
| 3. Start-stop/preheat switch | 21. Fuel filter |
| 4. Fuel solenoid fuse | 22. Ground connection |
| 5. Controller fuse | 23. Oil drain |
| 6. Hourmeter | 24. Fuel pump |
| 7. Controller | 25. Fuel inlet connection point |
| 8. Remote connection (at rear of controller) | 26. Fuel return connection point |
| 9. Air cleaner | 27. Oil check |
| 10. Lifting eye | 28. Heater coil relay |
| 11. Intake heater | 29. Low oil pressure shutdown |
| 12. Fuel solenoid | 30. Voltage regulator
(inside junction/circuit breaker box) |
| 13. Oil fill | 31. Coolant outlet |
| 14. Lifting eye | 32. Exhaust outlet |
| 15. High water temperature shutdown | 33. Battery charging alternator (behind guard) |
| 16. Coolant inlet | 34. Starter |
| 17. Oil fill | |
| 18. Generator nameplate | |

Figure 1-1. Service View of 20CCO RV with Remote Radiator (Typical)

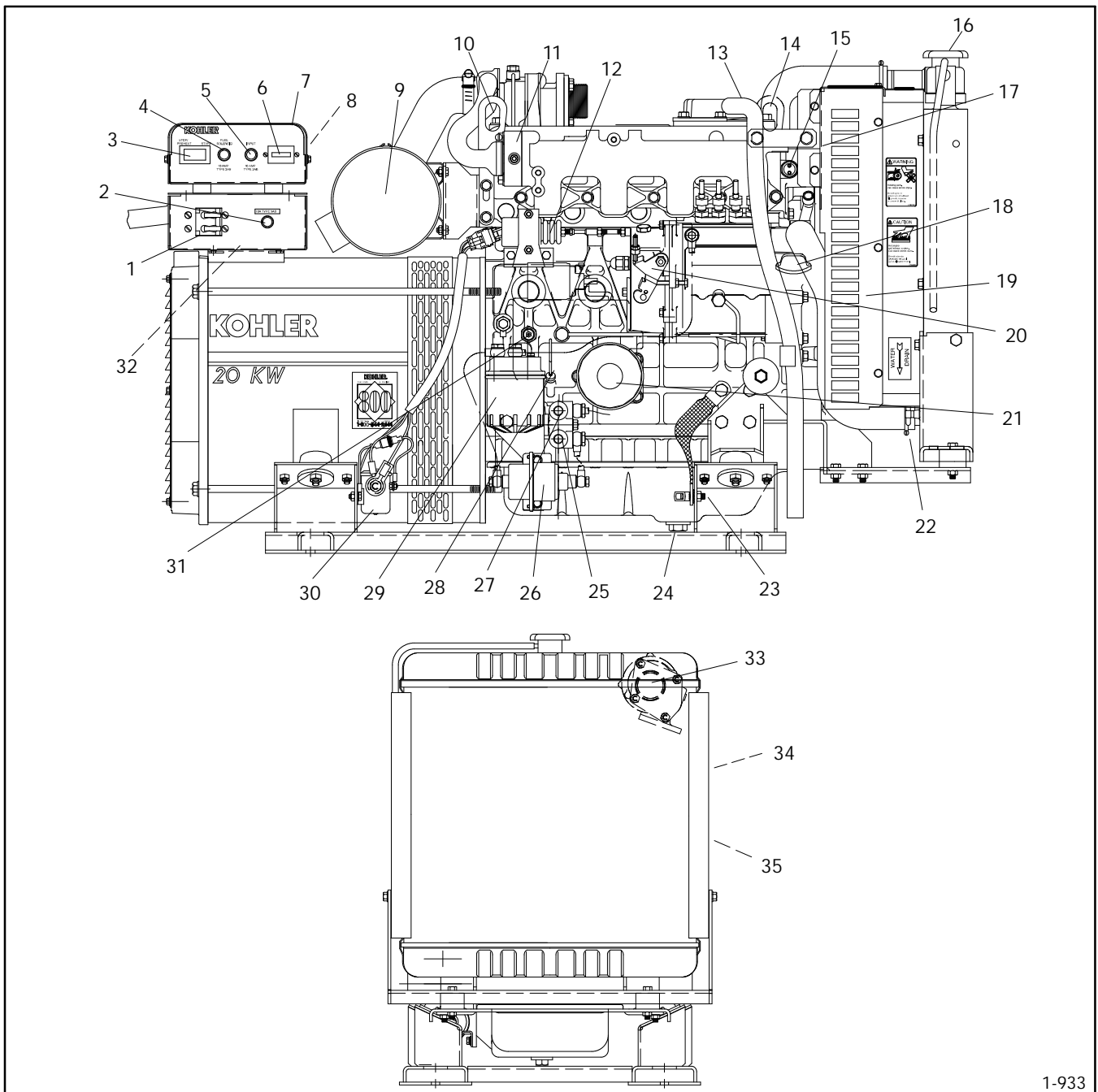

1-933

- | | |
|--|--|
| <ol style="list-style-type: none"> 1. Optional AC circuit breaker 2. Voltage regulator fuse 3. Start-stop/preheat switch 4. Fuel solenoid fuse 5. Controller fuse 6. Hourmeter 7. Controller 8. Remote connection (at rear of controller) 9. Air cleaner 10. Lifting eye 11. Intake heater 12. Fuel solenoid 13. Oil fill 14. Lifting eye 15. High water temperature shutdown 16. Pressure cap/initial coolant fill 17. Generator nameplate 18. Oil fill 19. In-line radiator | <ol style="list-style-type: none"> 20. Mechanical governor 21. Oil filter 22. Coolant drain 23. Ground connection 24. Oil drain 25. Fuel inlet connection point 26. Fuel pump 27. Fuel return connection point 28. Oil check 29. Fuel filter 30. Heater coil relay 31. Low oil pressure shutdown 32. Voltage regulator
(inside junction/circuit breaker box) 33. Exhaust outlet 34. Battery charging alternator (behind guard on non-service side of unit) 35. Starter (on non-service side of unit) |
|--|--|

Figure 1-2. Service View of 20CCO RV In-line Radiator (Typical)

Section 2. Operation

To ensure continued satisfactory operation, check the following items before each startup and at regular intervals.

Prestart Checklist

Air Cleaner. Keep air cleaner element clean. Install element to keep unfiltered air from entering engine.

Air Shrouding. Keep tight and in position.

Air Inlets. Keep clean and unobstructed.

Battery. Ensure tight battery connections. Maintain full battery electrolyte level.

Coolant Level. For cooling systems equipped with a coolant recovery tank, check coolant level at tank after the engine has cooled.

Maintain coolant level just below the filler neck, approximately 3/4 to 1 1/2 in. (19 to 33 mm).

A coolant solution of 50% ethylene glycol provides freezing protection of -34°F (-37°C) and overheating protection to 265°F (129°C). A coolant solution with less than 50% ethylene glycol may not provide adequate freezing and overheating protection. A coolant solution with more than 50% ethylene glycol can cause engine or component damage. Do not use alcohol or methanol antifreeze or mix them with the specified coolant. Consult the engine manufacturer's operation manual for engine coolant specifications.

Do not add coolant to a hot engine. Wait until engine has cooled. Adding coolant to a hot engine can cause the cylinder block or cylinder head to crack.

NOTE

Do not energize block heater before filling cooling system. Before energizing block heater, run engine until it is warm and refill radiator to purge air from the system. Immerse heater element in coolant to prevent block heater failure.

Drive Belts. Check belt condition and tension of radiator fan, water pump, and battery charging alternator belt(s).

Exhaust System. Keep exhaust outlet clear. Keep muffler and piping tight and in good condition.

Fuel Level. Keep tank(s) full to ensure adequate fuel supply.

Oil Level. Maintain oil level at or near full mark on dipstick but not over. Keep the oil level in the mechanical governor (if equipped) at or near the full level.

Operating Area. Check for obstructions that could block the flow of cooling air. Keep the air intake area clean. Do not leave rags, tools, or debris on or near the generator set.

Exercising the Generator

Run the generator set under load once each week for one hour with an operator present.

Operator should perform all prestart checks before starting the exercise procedure. While the generator set is running, listen for a smooth-running engine and visually inspect the generator set to ensure there are no fluid or exhaust leaks.

Start the generator set according to the starting procedure in the controller section of this manual.

Controller (Single-Phase)

Depending on application, the Kohler relay controller may be located at the set or at a location remote from the generator. Remote harnesses for the controller are available in 7.5- and 15-foot (2.3- and 4.6-meter) lengths. If the generator set has automatically stopped because of high water temperature (230°F/110°C) or low oil pressure (6.8 psi/46.9 kPa or less), correct the cause before restarting the set.

Refer to Figure 2-1 or Figure 2-2 and the following descriptions to identify controller components.

Generator Start and Stop/Preheat Switch. Switch serves the dual function of generator operation and generator preheat. When pressed to the preheat position, the preheat switch aids in cold weather starting. Refer to Start/Stop and Preheating procedures following.

Fuel Solenoid Fuse. 10-amp fuse protects fuel solenoid circuitry.

Controller Fuse. 10-amp fuse protects controller circuitry against damage if a short develops in the engine wiring system or the wiring to the remote start/stop switch.

Remote Switch Connection (located at rear of controller). Connect the remote start/stop switch to operate the generator set at a location remote from the set. Controller connections are made through the plug connector at the rear of the unit.

Hourmeter. Meter records total generator set operating hours for reference in maintenance schedule.

DC Circuit Breaker. Circuit breaker shuts down the generator set automatically after fault. See Circuit Protection following.

AC Circuit Breaker (optional). Circuit breaker trips when a fault is detected in the output circuit. Used to disconnect generator set during maintenance on vehicle wiring. To close circuit breaker(s), place breaker in ON position.

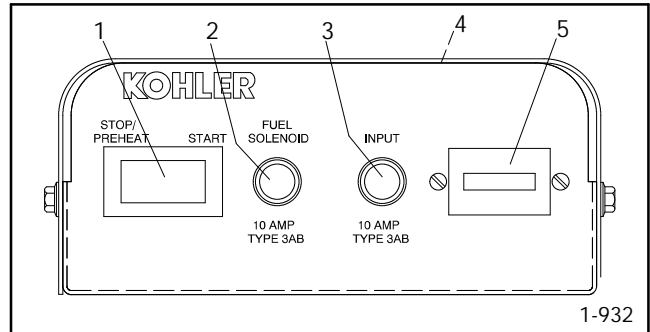

1. Generator start and stop/preheat switch
2. Fuel solenoid fuse
3. Controller fuse
4. Remote switch connection
5. Hourmeter

Figure 2-1. Single-Phase Controller

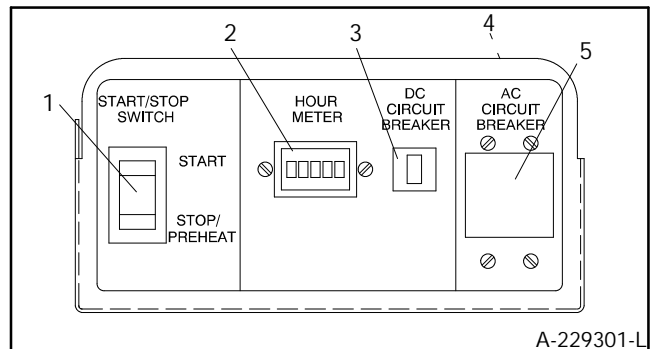

1. Generator start and stop/preheat switch
2. Hourmeter
3. DC circuit breaker
4. Remote switch connection
5. AC circuit breaker

Figure 2-2. Single-Phase Controller (spec PA-135322)

Controller (Three-Phase)

For identification of three-phase controller, see Figure 2-3.

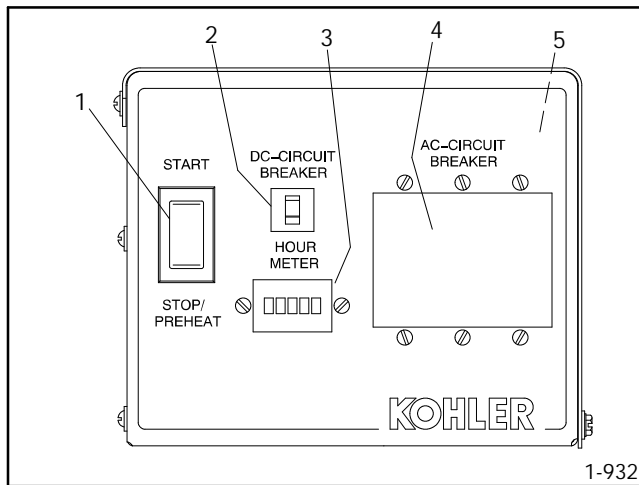

1. Generator start and stop preheat switch
2. DC circuit breaker
3. Hourmeter
4. AC circuit breaker
5. Fuel solenoid fuse

Figure 2-3. Three-Phase Controller

Generator Start and Stop Preheat Switch serves the dual function of generator operation and generator preheat. When pressed to the preheat position, the preheat switch aids in cold weather starting. Refer to Start/Stop and Preheating procedures following.

DC Circuit Breaker trips when a fault is detected in the DC circuitry. The generator set shuts down automatically after fault. See Circuit Protection following.

Hourmeter records total generator set operating hours for reference in maintenance schedule.

AC Circuit Breaker (optional) trips when a fault is detected in the output circuit. Used to disconnect generator set during maintenance of vehicle wiring. To close circuit breaker(s), place in ON position.

Fuel Solenoid Fuse (located inside the controller). 10-amp fuse protects fuel solenoid circuitry.

Preheat Feature

During cold weather starts (below 23°F [-5°C]), place controller start switch in STOP/PREHEAT position for 15 to 20 seconds before attempting to start the generator set. This provides energizing of the air heater coil. Do not energize preheat feature for more than 30 seconds or damage may occur.

Starting Procedure

Move the START-STOP/PREHEAT switch to the START position and hold in this position until the engine is running, then release. Do not crank engine continuously for more than 10 seconds at a time. If the engine does not start, allow a 60-second cooldown period between cranking attempts. If the unit fails to start after three attempts, contact an authorized service dealer/distributor for repair. Failure to follow these guidelines may result in burnout of the starter motor.

NOTE

If the engine starts and then stops, allow the engine to come to a complete stop before making a restart attempt. If the flywheel ring gear is still rotating when the starter pinion gear is engaged, the pinion gear will clash which may damage the ring gear teeth.

NOTE

If ambient temperature is below 23°F (-5°C), see Preheat Feature.

Stopping Procedure

Whenever possible, allow a brief cooling period by running the set at low or no load for a few minutes just prior to shutdown. To stop, move the switch to the STOP position and hold until the set comes to a complete halt. If the generator set shuts down automatically, identify and correct the problem before attempting to restart.

NOTE

Do not place Start-Stop/Preheat switch in Stop/Preheat position for more than 30 seconds or damage to the preheat feature may occur.

Fault Shutdowns

Low Oil Pressure Shutdown Switch

The low oil pressure (LOP) shutdown feature protects the engine against internal damage if the oil pressure drops below 6.8 psi (46.9 kPa) because of an oil pump fault or other engine malfunction. The LOP shutdown does not protect the set from damage due to operating with the oil level below the safe range— *IT IS NOT A LOW OIL LEVEL SHUTDOWN*. Check the oil level regularly and add oil as needed to prevent running out of oil. Location of the LOP shutdown switch is shown in Figure 2-4.

NOTE

This is not a low oil *level* shutdown. Maintain proper oil level to enable low oil pressure shutdown switch to function.

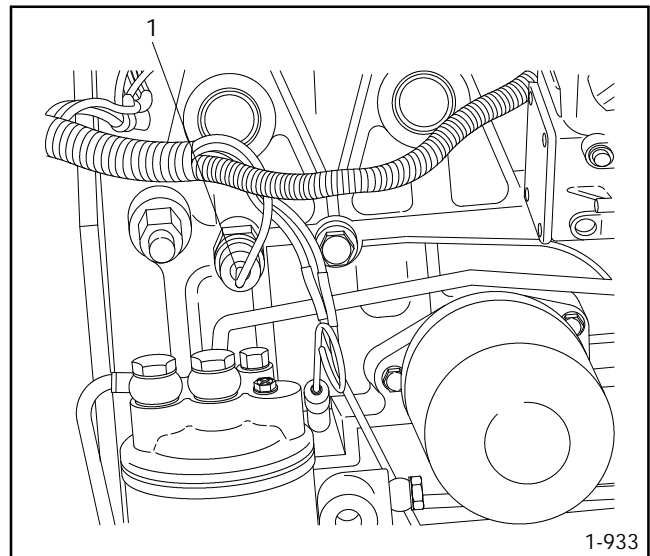

1. Low oil pressure switch

Figure 2-4. Low Oil Pressure Shutdown Switch

High Water Temperature Shutdown Switch

The generator set is also equipped with a high water temperature (HWT) shutdown switch. See Figure 2-5. The unit will automatically shut down when the engine coolant temperature exceeds 230°F (110°C). Correct the cause of the shutdown before restarting the generator.

NOTE

The high water temperature (HWT) shutdown switch is not a low coolant level switch. Maintain proper coolant level to enable HWT switch to function.

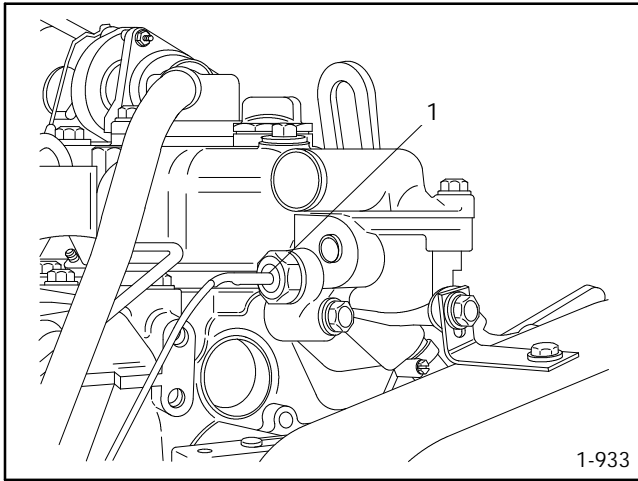

1. High water temperature switch

Figure 2-5. High Water Temperature Shutdown Switch

Circuit Protection

Refer to Figure 2-6 and the following descriptions to identify controller components.

10-Amp Fuel Solenoid Fuse. A replaceable 10-amp fuse protects the fuel solenoid. (On three-phase models the in-line fuse is mounted inside the controller.) If this fuse is blown, the generator shuts down. If the fuse is replaced and then blows again, have the generator set examined by an authorized Kohler service distributor/dealer.

10-Amp Controller-Input Fuse (Single-Phase) or Circuit Breaker (Three-Phase). A replaceable 10-amp fuse or circuit breaker protects the controller circuitry. If the generator will not crank and the battery and/or connections are intact, the controller fuse/breaker may be blown or tripped. Contact an authorized Kohler service distributor/dealer if fuse/breaker blows/trips repeatedly.

10-Amp PBIIE Voltage Regulator Fuse (Single-Phase Models Only). A replaceable 10-amp fuse protects the voltage regulator circuitry. If this fuse is blown, the generator set shuts down. If this fuse is replaced and then blows again, have the generator set examined by an authorized Kohler service distributor/dealer.

Optional AC Circuit Breaker(s) trips when a fault is detected in the AC output circuit. See Section 4– Troubleshooting to determine cause of fault. After fault is corrected, reset AC circuit breaker by placing in ON position.

DC Circuit Breaker will trip when a fault occurs in the controller circuit. See Section 4– Troubleshooting to determine cause of fault. After fault is corrected, reset DC circuit breaker by depressing center button.

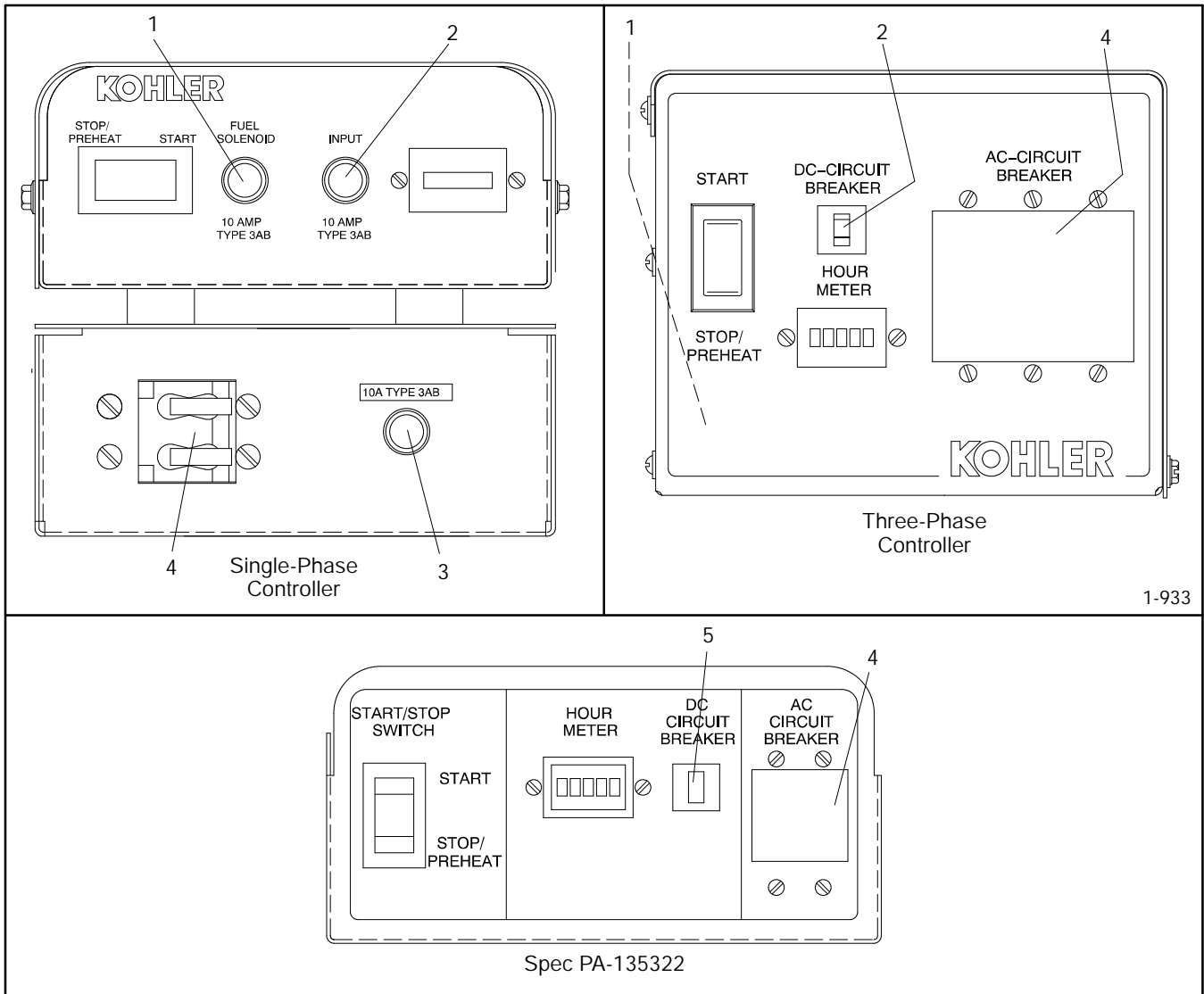

1-933

1. 10-amp fuel solenoid fuse
2. 10-amp controller-input fuse or circuit breaker
3. 10-amp PBIIE voltage regulator fuse

4. Optional AC circuit breaker
5. DC circuit breaker

Figure 2-6. Circuit Protection

Section 3. Scheduled Maintenance

General

Schedule routine maintenance using the Maintenance Schedule following and the hourmeter located on the generator controller. If the generator will be subject to extreme operating conditions, service the unit more frequently. Instructions to perform most of the scheduled services are provided in the following pages. Items in the maintenance schedule marked with an asterisk (*) should be performed more often if the generator set is operated in dirty, dusty conditions. Items identified with asterisks (**) should be performed only by an authorized Kohler service dealer/distributor. Tools and instruments required for these additional steps are usually not available to the generator set owner. For this reason, return the set periodically to an authorized service distributor/dealer for complete servicing and tune-up. Such service improves performance and continuous satisfactory operation during a long trouble-free service life.

NOTE

Perform the items listed in the maintenance schedule at the designated intervals for the life of the generator. For example, an item serviced every 100 hours or 3 months must also be serviced after 200 hours or 6 months, 300 hours or 9 months, etc. The generator will eventually accumulate enough hours to warrant a complete overhaul. The exact time at which extensive service will be necessary cannot be predicted. However, rough operation, lack of power, and excessive oil use indicate serious generator set problems. As part of a preventive maintenance program, service the engine (clean cylinder head, inspect valves, check compression, etc.) and generator (replace bearing, inspect wiring, remove debris, etc.) at the earliest indication that a serious problem exists.

Perform Service at Intervals Indicated (X)	Before Each Startup	Every 50 Hours or 1 Month	Every 100 Hours or 3 Months	Every 300 Hours or 6 Months	Every 500 Hours or Yearly
<u>FUEL SYSTEM</u>					
Check the fuel level	X				
Fill fuel tank	X				
Remove sediment from fuel tank	X				
Replace the fuel filter element		X		X	
		(Break-in Period)			
Check the injection timing**					X
Check governor operation and adjust as necessary**					X
Check the injection spray condition**					X
<u>LUBRICATION SYSTEM</u>					
Check the oil level in crankcase	X				
Replace the oil in crankcase*		X	X		
		(Break-in Period)			
Replace the lube oil filter element*		X	X		
		(Break-in Period)			
<u>COOLING SYSTEM</u>					
Check coolant level	X				
Adjust the tension of water pump V-belt		X	X		
		(Break-in Period)			
Change coolant					X
Clean radiator fins, inspect hoses			X		
<u>AIR CLEANER</u>					
Replace the air cleaner element*				X	
Clean the breather pipe*			X		
<u>ELECTRICAL SYSTEM</u>					
Verify proper operation of gauges, if equipped	X				
Check the electrolyte level in the battery	X				
Check the electrical connections		X			
Check the battery specific gravity				X	
Adjust battery charging alternator V-belt		X	X		
		(Break-in Period)			
<u>CYLINDER HEAD</u>					
Check for leakage of water and oil	X	X			
Retighten all major nuts and bolts		X			X
		(Break-in Period)			
Check mounting bolts and vibromounts for tightness				X	
Retighten the cylinder head bolts**					X
Adjust intake and exhaust valve clearance**				X	
<u>GENERATOR</u>					
Blow dust out of generator*					X
Clean slip rings and inspect brushes (Single-phase units only)**				X	

* Service more frequently if operated in dusty areas.
** Should be performed by an authorized Kohler Service Dealer/Distributor.

Lubrication System

Oil Selection

The selection of engine oil is very important to a diesel engine. If an unsuitable oil is used or an oil change is neglected, damage and a shorter engine life may result. Oil must meet the American Petroleum Institute (API) classification of CC or CD. Avoid mixing different brands of oils and lubricants; oils of different manufacturers may be incompatible and deteriorate when mixed. Recommended SAE viscosity designations for given temperature ranges in which the generator set will be operated are listed in Figure 3-1.

NOTE

Failure to observe these standards may cause inadequate oil pressure and cold-starting difficulties.

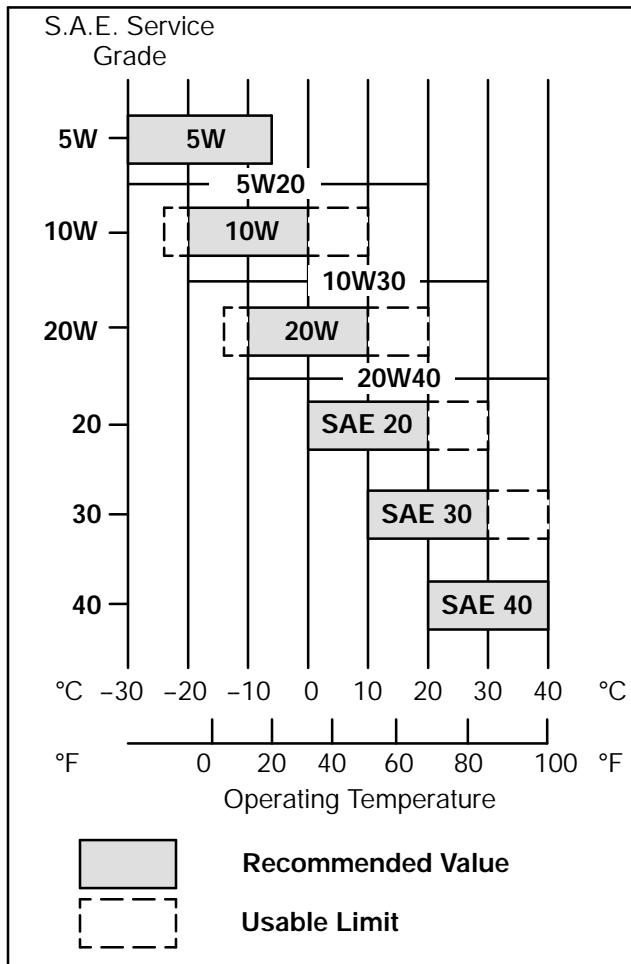
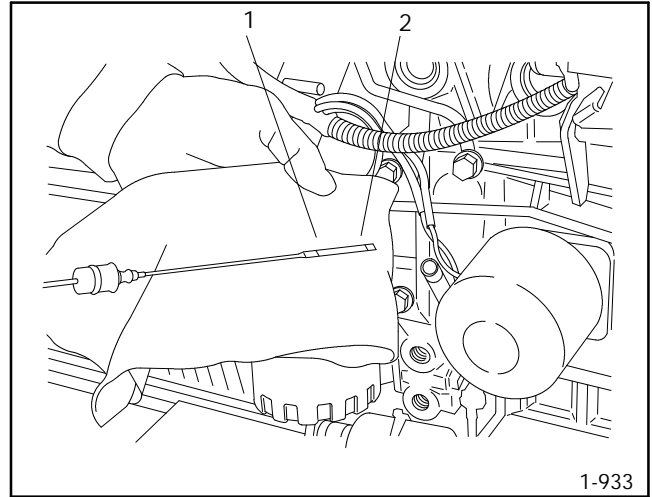

Figure 3-1. Engine Oil Selection.

Oil Check

Check crankcase oil level daily or before each start to ensure that the level is in the safe range. To check oil level, remove oil dipstick and wipe dipstick clean (see Figure 3-2). Reposition dipstick in crankcase and push it all the way down into the tube. Remove dipstick and check the level. Oil level should read between MIN and MAX marks on dipstick. Do not operate set if oil level exceeds the MAX mark or registers below the MIN mark on dipstick.



1. MAX level
2. MIN level

Figure 3-2. Oil Level Check

NOTE

Do not check oil level when the set is in operation. The engine must be stopped and on a level surface when checking oil. Obtain the most accurate oil reading by shutting down the generator and waiting several minutes before checking oil.

Oil Change

On a new engine, change the oil after the first 50 hours of operation and thereafter at 100-hour intervals or 3 months, whichever occurs first. Change oil more frequently under dirty, dusty conditions. Change oil while the engine is still warm.

1. Place a container below the oil drain hole and remove oil drain plug. Allow sufficient time for the old oil to drain completely. Replace oil drain plug. Dispose of used engine oil in an environmentally safe manner. Take used oil to a suitable collection facility in your area. *DO NOT POUR USED OIL ON THE GROUND, DOWN SEWERS, OR INTO STREAMS OR OTHER BODIES OF WATER.*
2. Remove oil fill cap. One is located on the rocker-arm cover and one is located near the fuel injector pump. See Figure 3-4.
3. Fill crankcase with proper amount and type of oil; see Figure 3-3 and Oil Selection.
4. If replacing engine oil filter, see Oil Filter following.
5. Start the generator set and check for oil leaks.
6. Stop the generator set. Remove the dipstick and wipe clean, reinsert as far as possible, and remove to check oil level. Add oil, as necessary, to bring level up to MAX mark.

OIL CAPACITY (with Filter) qts. (L)	
15 kW	6.1 (5.8)
20 kW	6.1 (5.8)

Figure 3-3.

NOTE

Too high an oil level causes high oil consumption and carbonizing of the engine. Low oil level will cause engine damage.

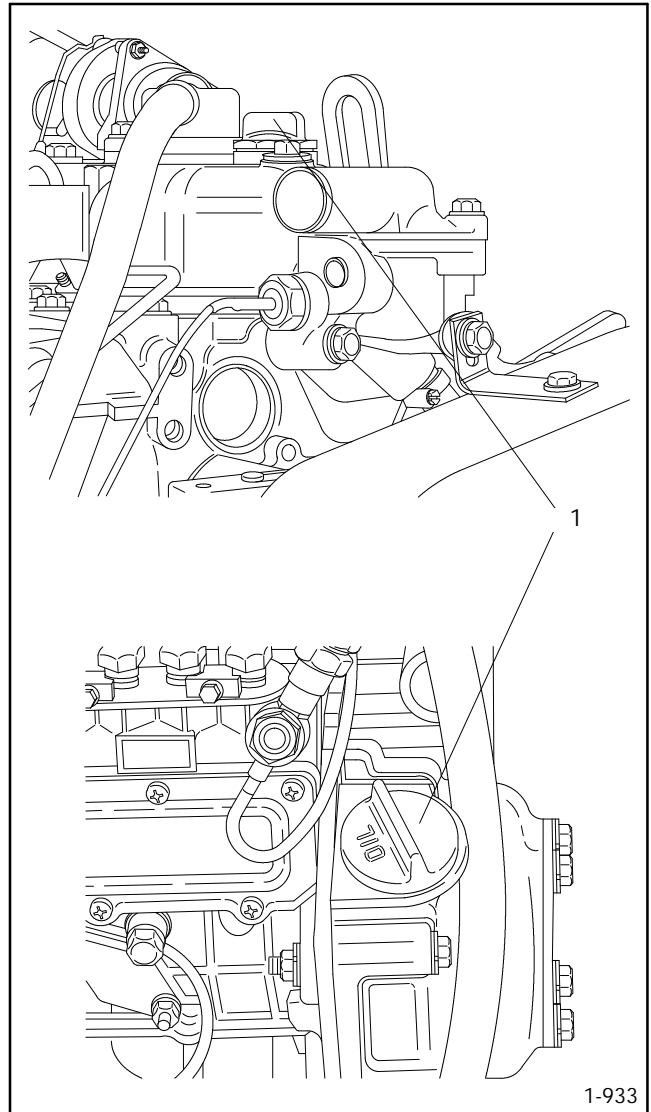

1. Oil fill

Figure 3-4. Oil Fill Locations

Oil Filter

Replace the oil filter for the first time after 50 hours or 1 month of operation and then every 100 hours or 3 months. Change more frequently if operating in dirty, dusty conditions. See Figure 3-5 and refer to the following procedure.

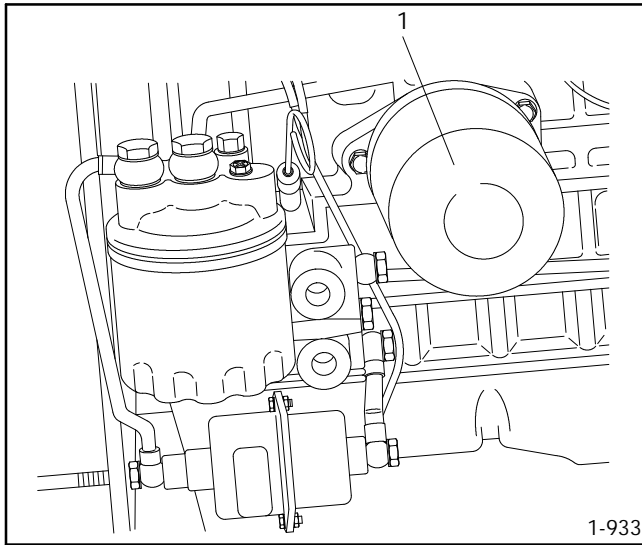

1. Oil filter

Figure 3-5. Oil Filter Location

1. Loosen oil filter by turning with a filter wrench in a counterclockwise direction. Use rags to clean up spilled oil. Remove and discard.
2. Clean contact surface on oil filter adapter.
3. Lightly lubricate the gasket surface of the new oil filter with the fresh engine oil. Thread oil filter to adapter until gasket makes contact, hand tighten an additional one-half turn.
4. Start the generator set and check for oil leaks.
5. Stop the generator set. Remove dipstick and wipe clean. Reinsert as far as possible, then remove to check oil level. Add oil, as necessary, to bring level up to MAX level.

Fuel System

Specification

Use a clean, good quality No. 2-D (DIN 51 601) diesel fuel oil. The fuel must meet the requirements of the American Society of Testing and Materials (ASTM) diesel fuel classification D975 (Federal Specification W-F-800a). Cleanliness of the fuel is especially important on diesel engines which have easily clogged precision fuel injectors and pumps. See chart below.

United States	ASTM/D975	No. 2-D Diesel
United Kingdom	BS2869	Class A1 or Class A2

Other Considerations:

Sulfur Content Less than 0.5%
Sediment/Water Content Not to exceed 0.1%
Cetane Number 45 minimum
Pour point At least 10°F (5.6°C)
Below the lowest outside
air temperature

NOTE

Never store diesel fuel in galvanized containers; diesel fuel and the galvanized coating react chemically to produce flaking which quickly clogs filters or causes failure of the fuel pump or injectors. Do not run the generator set out of fuel; air will be drawn into the fuel lines and the entire system will have to be bled before the unit can be restarted.

NOTE

Avoid storing fuel over long periods of time. Take special precautions to keep all dirt, water, and other contaminants out of the fuel. Storage tanks containing diesel fuel contaminated with water may cause the growth of microbes. The presence of microbes will form a slime which will clog fuel filters and lines.

Fuel Filter

The fuel filter serves to remove water and dirt contained in the fuel. The fuel filter element is paper and no attempt should be made to clean it. Its useful life will be determined largely by the quality and condition of the fuel used. Under normal conditions, replace the fuel filter element for the first time after 50 hours or one month and then every 300 hours or six months. See Figure 3-6 for location and use the following procedure to service the fuel filter.

1. Loosen the fuel filter by turning in a counterclockwise direction. Use rags to clean up spilled fuel oil. Remove and discard filter.
2. Clean contact surface on the fuel filter adapter.
3. Lightly lubricate the gasket surface of the new fuel filter with fresh fuel oil. Thread the fuel filter to the adapter until the gasket makes contact, hand tighten an additional one-half turn.

See Bleeding section following.

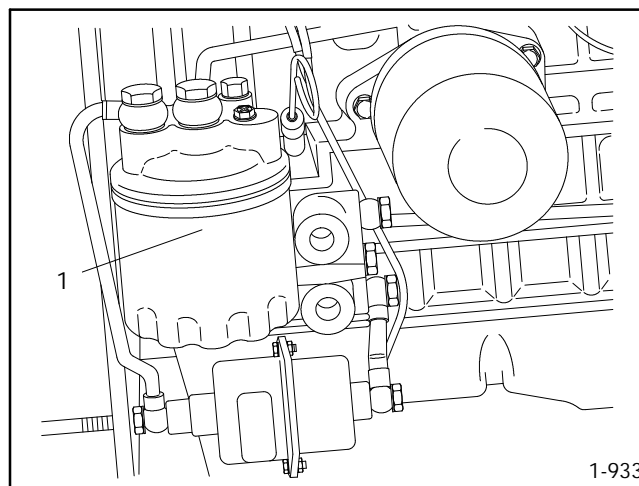

1. Fuel filter

Figure 3-6. Fuel Filter Location

Bleeding the Fuel System

If the generator set engine runs out of fuel, air leaks develop in the suction side of the fuel system, or the fuel filter is replaced, bleed the entire system to prevent starting failures and/or erratic operation. See Figure 3-7 and refer to the following procedure.

1. Disconnect lead 71A from the starter relay to disable cranking during the bleeding procedure.
2. Fill the fuel tank.
3. Loosen the line connection at the fuel filter.
4. Crank the engine until fuel (free from bubbles) flows from the loosened connection. Tighten the fuel line connection.
5. Loosen the small vent screw (with Phillips head) on the fuel filter.
6. Crank the engine until fuel (free from bubbles) flows from this point. Tighten vent screw.
7. Loosen the line connection (bleed point) at the fuel injection pump inlet.
8. Crank the engine to operate the fuel pump until fuel (free from bubbles) flows from this loosened connection. Tighten line connection.
9. Reconnect lead 71A to the starter relay.

 **WARNING**

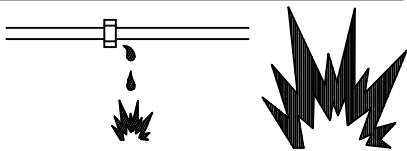

**Explosive fuel vapors.
Can cause severe injury or death.**

Use extreme care when handling, storing,
and using fuels.

Draining fuel system. Explosive fuel vapors can cause severe injury or death. Spilled fuel can cause an explosion. Use a container to catch fuel when draining fuel system. Wipe up all spilled fuel after draining system.

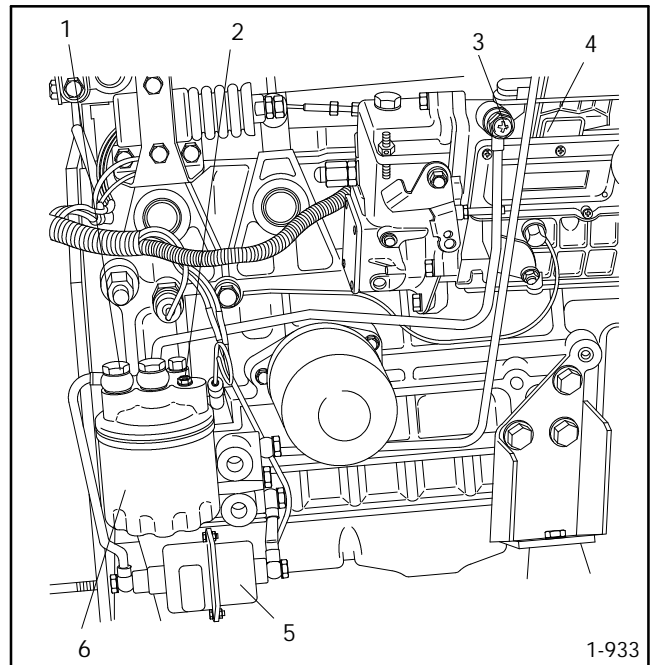

1. Line connection (bleed point)
2. Vent screw
3. Line connection (bleed point)
4. Fuel injection pump
5. Electric fuel pump
6. Fuel filter

Figure 3-7. Bleeding the Fuel System

Fuel Solenoid

The fuel solenoid (Figure 3-8) stops fuel flow through the fuel injection pump when the start-stop/preheat switch is placed in the STOP position. If the fuel solenoid is removed or the setting is believed incorrect, readjust according to the following procedure. Do not modify the solenoid linkage during reconnection.

1. With the fuel solenoid mounted to the engine block, compress the plunger and adjust the fuel-solenoid linkage so that the linkage connects to the fuel control lever $1/16$ in (1.6 mm) before the lever contacts internal full-open stop.
2. Attach the balljoint to the fuel-solenoid linkage.

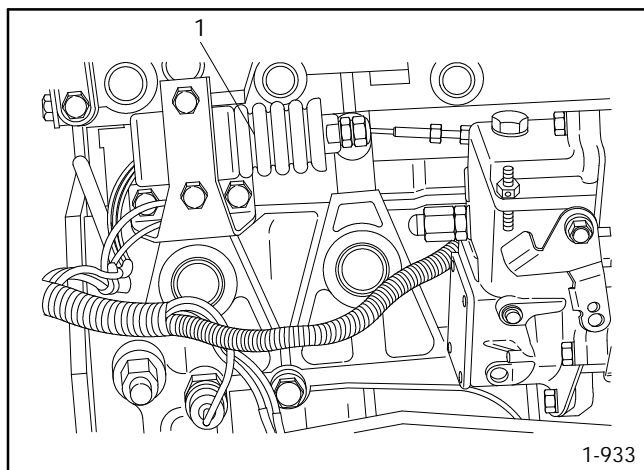

1. Fuel solenoid

Figure 3-8. Fuel Solenoid Location

Air Cleaner Service

Replace the paper element at 300-hour or 6-month intervals; change more frequently if operating under dirty, dusty conditions. Operating the set with a dirty air cleaner element may cause engine damage and increased fuel consumption. At the time of service, clean the air cleaner breather pipe and remove all dust and foreign matter from the air cleaner housing. See Figure 3-9 and refer to the following procedure.

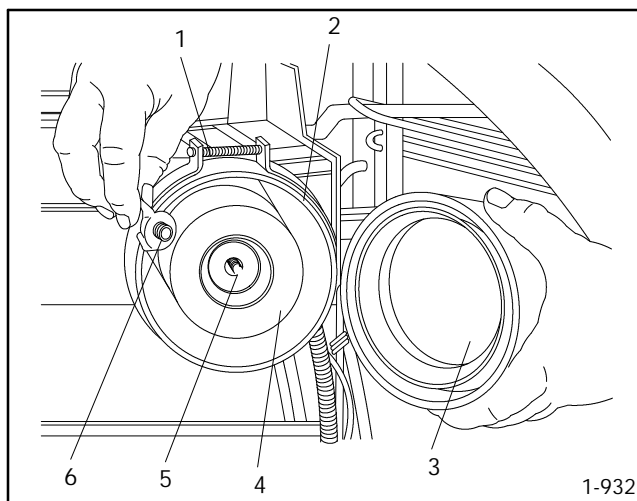

1. Eyebolt/clamp
2. Base
3. Cover
4. Element
5. Threaded rod
6. Wing nut

Figure 3-9. Air Cleaner Components

1. Loosen eyebolt and clamp to remove the air cleaner cover.
2. Remove wing nut and slide air cleaner element from the threaded rod.
3. Clean dry element by tapping edges on a hard surface. Replace if damaged or very dirty.

NOTE

Do not attempt to clean dry-type element in any liquid or with compressed air as this will damage paper filter material.

4. Wipe dirt or dust accumulation from cover and base. Check that all clamps are tight on inlet/outlet connections.
5. Install air cleaner element on threaded rod. Tighten wing nut making sure parts fit properly.
6. Position cover with arrow up; place clamp over base and cover, and tighten eyebolt.

Governor

The centrifugal, mechanical-type governor keeps the engine speed constant by automatically adjusting the amount of fuel supplied to the engine according to changes in the load. No regular service is required on the unit. The governor is adjusted during run-in at the factory, and further adjustment is not necessary unless encountering greatly varying load conditions or poor governor control develops after extended usage.

60-Hz generator sets are designed to operate at 60–63 Hz, 1800 rpm under full load and 1890 rpm under no load.

50-Hz generator sets are designed to operate at 50-52.5 Hz, 1500 rpm under full load and 1575 rpm under no load.

To check speed, use a hand-held tachometer or frequency meter. See Figure 3-10. Loosen the locking nut on the speed-adjusting screw. Turn the screw in a counterclockwise direction to increase speed and

frequency or in a clockwise direction to decrease speed. Tighten the lock nut to secure at new setting.

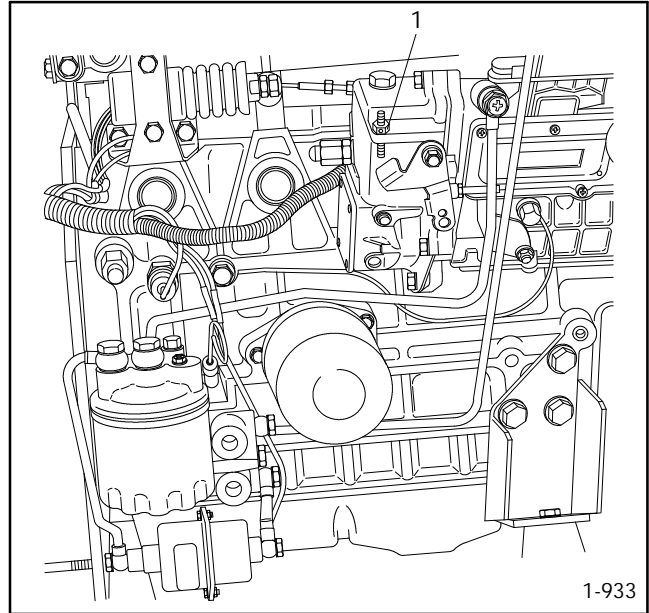

1. Locking nut

Figure 3-10. Governor

Cooling System

WARNING



Hot coolant and steam. Can cause severe injury or death.

Before removing pressure cap, stop generator set and allow it to cool. Then loosen pressure cap to relieve pressure.

Checking coolant level. Hot coolant can cause severe injury or death. Allow engine to cool. Release pressure from cooling system before opening pressure cap. To release pressure, cover the pressure cap with a thick cloth; then slowly turn it counterclockwise to the first stop. Remove cap after pressure has been completely released and the engine has cooled. Check coolant level at tank if generator set is equipped with a coolant recovery tank.

To prevent the generator set from shutting down or becoming damaged because of overheating, keep the cooling air inlets clean and unobstructed at all times. Inspect the exterior of the radiator for obstructions; remove all dirt and foreign material with a soft brush or cloth to avoid damaging radiator fins. Check all hoses and connections for leaks and replace any hoses that are cracked, frayed, or spongy. When making coolant level checks, check condition of the radiator cap rubber seal; replace if cracked or deteriorating. Remove dirt and other debris from the radiator cap and filler neck.

Coolant capacity for the 15/20 kW in-line radiator model is 4 qts. 16 oz. (4.26 L). Consult the coach manufacturer

for remote radiator cooling system capacity. Drain petcocks are provided on the bottom tank of the radiator and another in the engine block to drain the system. When draining the coolant, remove the radiator cap and open the block drain located near the flywheel housing; this will allow the entire system to drain and prevent air pockets from forming and restricting coolant passage in the block. To refill the cooling system, close the drain petcock and fill the radiator to the proper level with the recommended coolant mixture. See Figure 3-12 for coolant fill location. Replace the radiator cap and operate the engine until the thermostat opens and the radiator upper hose becomes hot. Stop the engine and allow to cool. Add coolant to the radiator to just below the overflow tube on the filler neck. Replace the radiator cap.

A coolant solution of 50% ethylene glycol and 50% clean, softened water is required to inhibit corrosion, prevent freezing to -34°F (-37°C), and to improve cooling. The antifreeze should contain a rust inhibitor and be changed every two years. Do not use alcohol or methanol antifreeze or mix them with the coolant. Do not add coolant to an overheated engine until the engine has cooled. Adding coolant to an extremely hot engine can cause a cracked block or cylinder head.

Check coolant level frequently and add antifreeze solution as needed to maintain level just below the overflow tube and at the min level in the coolant recovery tank when cold (max when hot).

NOTE

Give special attention when checking for proper coolant level. After a radiator has been drained, some time is normally required before complete refill of all air cavities takes place.

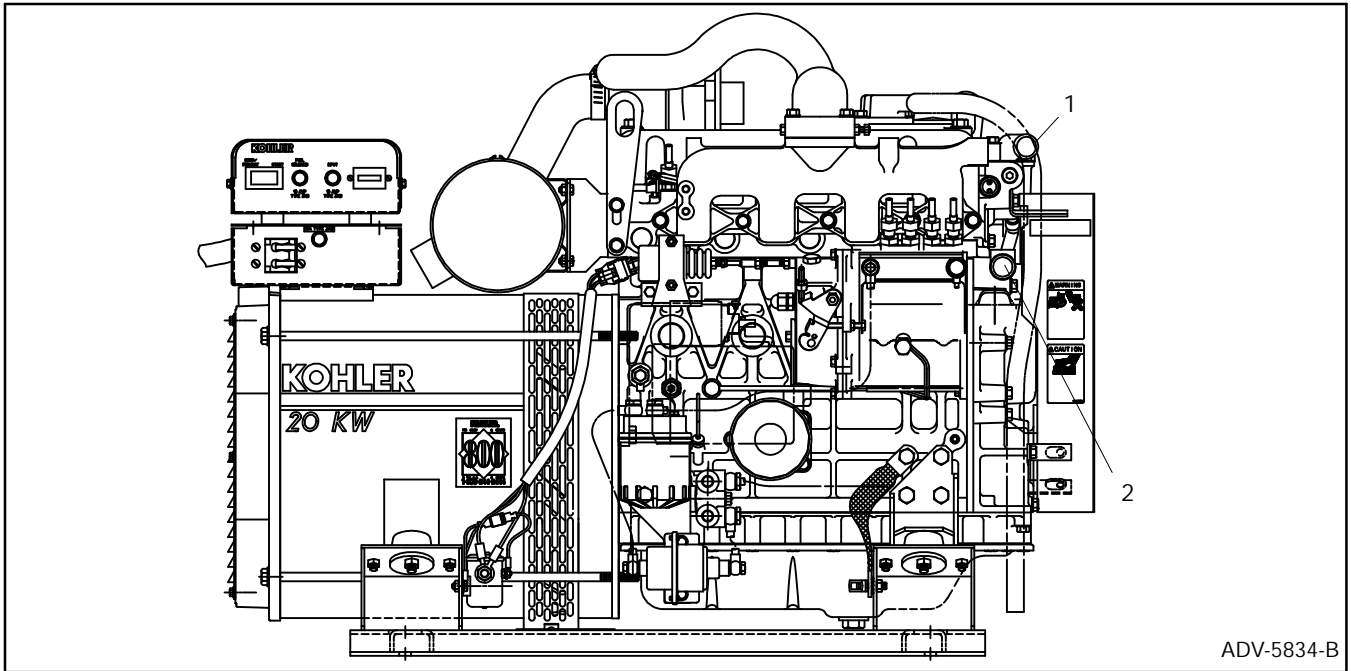

ADV-5834-B

1. Coolant outlet

2. Coolant inlet

Figure 3-11. Coolant Fill and Coolant Drain Connections (Remote Radiator Model)

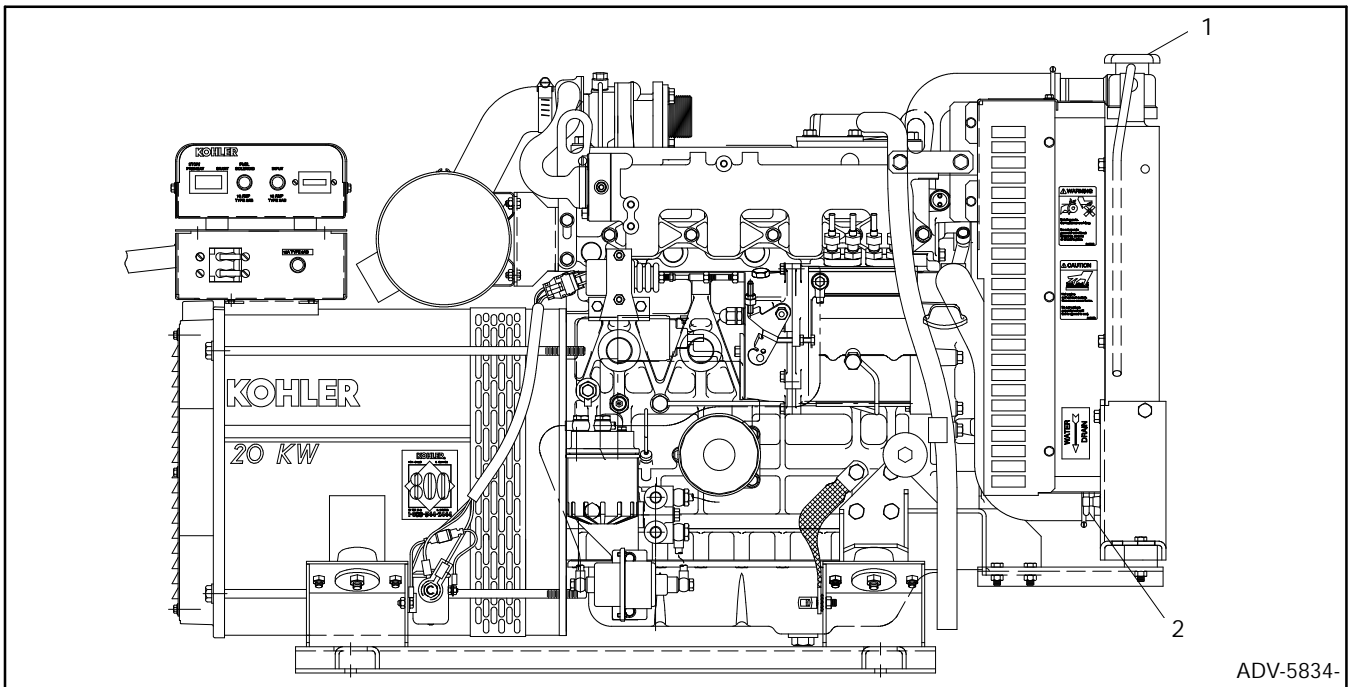

ADV-5834-

1. Initial coolant fill

2. Coolant drain

Figure 3-12. Initial Coolant Fill and Coolant Drain Locations (In-line Radiator Model)

Belt Tension

Adjust the tension of the alternator/fan belt so that it can be depressed about 0.4-0.6 in. (10-15 mm) when applying finger pressure. See Figure 3-13. Use the following procedure to adjust the belt.

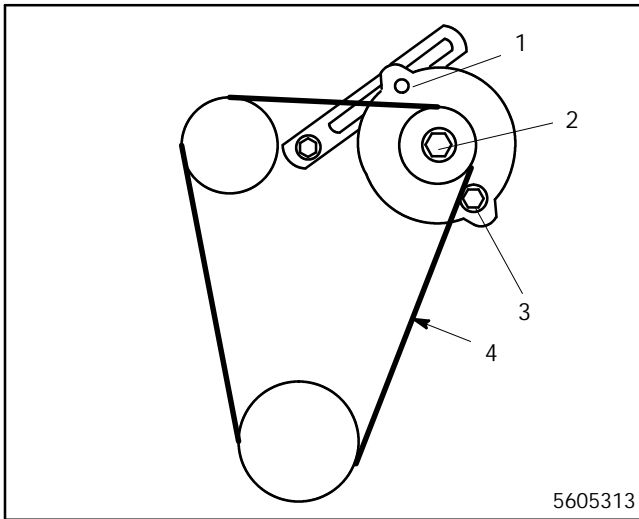

1. Adjusting screw
2. Battery charging alternator pulley
3. Alternator pivot screw
4. Check alternator belt tension here

Figure 3-13. Belt Tension

1. Disconnect battery, negative lead first.
2. Loosen pivot and adjusting screws.
3. While prying battery-charging alternator outward, tighten adjusting screw.
4. Tighten pivot screw.
5. Recheck and adjust as necessary.
6. Reconnect battery, negative lead last.

NOTE

Also, check fan belt for cracks or tears and replace if necessary.

⚠ WARNING

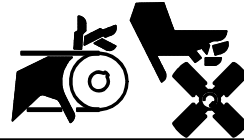

**Rotating parts.
Can cause severe injury or death.**

Do not operate generator set without all guards, screens, and covers in place.

Exposed moving parts can cause severe injury or death. Keep hands, feet, hair, and clothing away from belts and pulleys when unit is running. Replace guards, covers, and screens before operating generator set.

Battery Charging

Your generator is equipped with a 40-amp, belt-driven battery charging alternator. See Figure 3-14. It is attached to the engine block by a bracket and keeps the battery constantly charged. Be sure to observe battery polarity when connecting the battery to the generator set. The alternator requires no maintenance other than maintaining belt tension. To adjust the alternator belt tension, see Belt Tension.

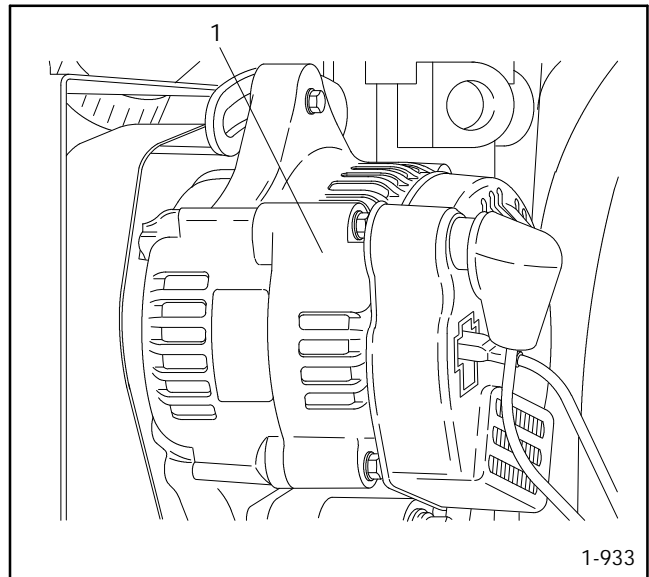

1. Battery charging alternator

Figure 3-14. Battery Charging Alternator

Battery

Use a 12-volt battery with a rating of at least 625 cold cranking amps. When using a Maintenance-Free battery, it is not necessary to check the specific gravity or electrolyte level. Otherwise perform these procedures at the intervals specified in the Maintenance Schedule. A negative ground system is used. Battery connections are shown on the wiring diagrams. Make sure that the battery is properly connected and the terminals are tight.

NOTE

The generator set will not start if the battery connections are made in reverse.

WARNING



Sulfuric acid in batteries. Can cause severe injury or death.

Use protective goggles and clothes. Battery acid can cause permanent damage to eyes, burn skin, and eat holes in clothing.

Battery acid. Sulfuric acid in batteries can cause severe injury or death. Sulfuric acid in battery can cause permanent damage to eyes, burn skin, and eat holes in clothing. Always wear splash-proof safety goggles when working near the battery. If battery acid is splashed in the eyes or on skin, immediately flush the affected area for 15 minutes with large quantities of clean water. Seek immediate medical aid in the case of eye contact. Never add acid to a battery after placing the battery in service, as this may result in hazardous spattering of battery acid.

Battery gases. Explosion can cause severe injury or death.

Battery gases can cause an explosion. Do not smoke or permit flame or spark to occur near a battery at any time, particularly when it is charging. Avoid touching terminals with tools, etc., to prevent burns and sparks that could cause an explosion. Remove wristwatch, rings, and any other jewelry before handling battery. Never connect negative (-) battery cable to positive (+) connection terminal of starter solenoid. Do not test battery condition by shorting terminals together. Sparks could ignite battery gases or fuel vapors. Ventilate any compartment containing batteries to prevent accumulation of explosive gases. To avoid sparks, do not disturb battery charger connections while battery is being charged. Always turn battery charger off before disconnecting battery connections. Remove negative lead first and reconnect it last when disconnecting battery.

Cleaning

Keep battery clean by wiping it with a damp cloth. Keep all electrical connections dry and tight. If corrosion is present, disconnect cables from battery and remove corrosion with a wire brush. Clean battery and cables with a solution of baking soda and water. Be careful that cleaning solution does not enter battery cells. When cleaning is complete, flush battery and cables with clean water and wipe with a dry cloth. After the battery cables are reconnected, coat terminals with petroleum jelly or other nonconductive grease.

Checking Electrolyte Level

Check the electrolyte level before each startup. Remove filler caps and check that electrolyte level is up to bottoms of filler holes. See Figure 3-15. Refill as necessary with distilled water or clean tap water. DO NOT add fresh electrolyte! Be sure filler caps are tight.

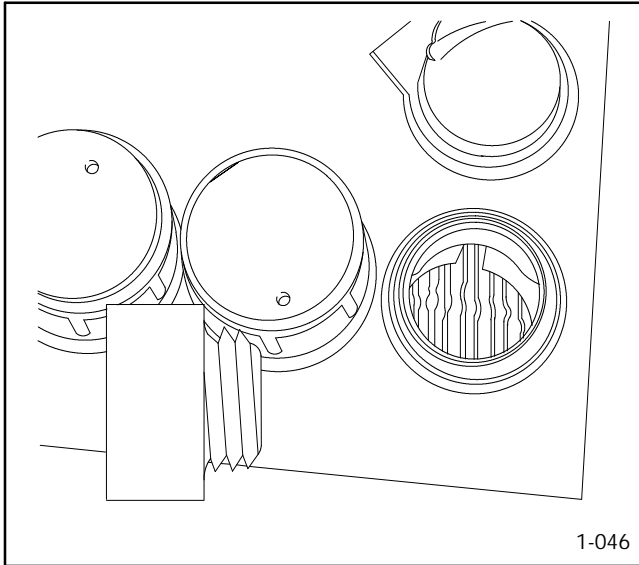

Figure 3-15. Battery Electrolyte Level

Checking Specific Gravity

Use a battery hydrometer to check the specific gravity of the electrolyte in each battery cell. While holding the hydrometer vertical, read the number on the glass bulb at the top of the electrolyte level. If the hydrometer used does not have a correction table, use the one in Figure 3-16. Determine specific gravity and electrolyte temperature of battery cells. Locate temperature in Figure 3-16 and adjust specific gravity by amount shown. The battery is fully charged if the specific gravity is 1.260 at an electrolyte temperature of 80°F (26.7°C). The difference between specific gravities of each cell should not exceed ± 0.01 . Charge the battery if the specific gravity is below 1.215 at an electrolyte temperature of 80°F (26.7°C).

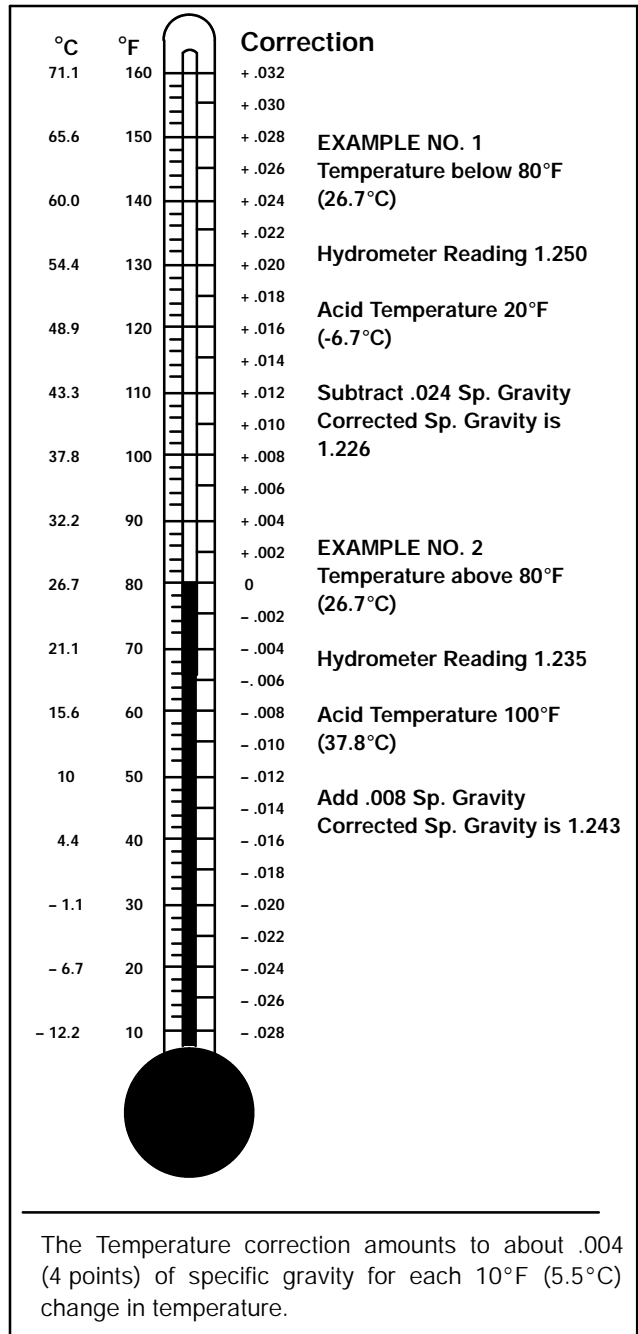

Figure 3-16. Specific Gravity Temperature Correction

Gauge Connections for Single-Phase Models

The 15/20 kW generator sets may be equipped with sending devices for optional connection to oil pressure and water temperature gauges (not provided).

Because lead 10 (from water temperature sender) and lead 11 (from oil pressure sender) may not appear at controller plug J4 or P4, it may be necessary to access these leads in the engine harness or remote harness if used. Leads 10 and 11 do not run the full length of the

remote harness. Retrieve the ends of these leads from the harness for connection to the oil pressure and water temperature gauges. The installer may also elect to run separate leads from each sender directly to the gauges and bypass the harnesses entirely. See Figure 3-17 and refer to the wiring diagram in Section 5. Use insulink or similar connectors at all spliced connections to ensure reliable operation of the senders and gauges.

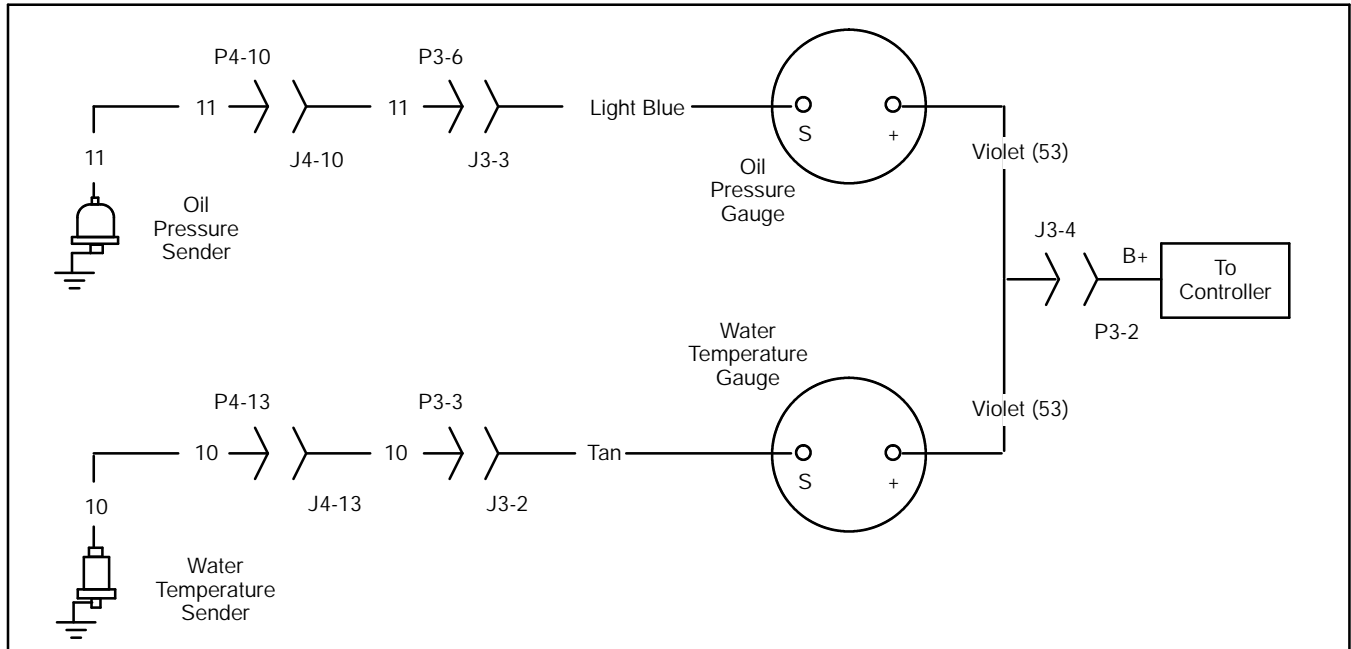

Figure 3-17. Oil Pressure/Water Temperature Sender Connections

Wattage Requirements

If the rated capacity of your generator is exceeded, the circuit breaker(s) located in the controller trips to protect the generator against damage. This could be caused by a short in the AC circuit in your vehicle or simply by having too many appliances or tools turned on simultaneously time resulting in an overload condition. If the circuit breaker(s) trips, the set may continue running but there will be no AC output to the protected circuit. Before resetting the circuit breaker(s), turn off some of the appliances or tools and lights inside the vehicle to bring the load down within the rated limits of the set. If this is done and the circuit breaker(s) trips again after being reset, a short circuit is indicated. In this event, turn off the set and have a qualified electrician locate and correct the cause of the short circuit.

The average wattage requirements of some common RV/Mobile appliances/tools and motor loads are listed in the following charts. Use these figures to calculate the total load on your set to avoid having the circuit breaker trip because of overload. The lighting load is easily determined by adding the wattage rating of each bulb in the circuit. Check the nameplate rating on motors and appliances in your vehicle for exact wattage requirements.

Electrical Appliance	Rating (Watts)
Blanket	50-250
Blender	600
Broiler	1350
Fan, Air Circulating	25-100
Fan, Furnace	270
Heater, Space	750-1500
Heater, Water	1500
Pan, Frying	1200
Percolator, Coffee	650
Radio	50-100
Television	300-750
Toaster	750-1200

Figure 3-18. Appliance Average Wattage Ratings

Construction Tools	Motor Starting Watts	Running Watts
Air Compressor (Small)	1500	725
Air Compressor, 3/4 hp	4000+	2000
Drill, 1/4 in.	500	250
Drill, 3/8 in.	600	350
Drill, 1/2 in.	800	600
Grinder, 1/2 hp	1500	1200
Hammer, Demolition	2000	1800
Hammer, HD Rotary	1500	1200
Paint Sprayer (Airless)	400	240
Polisher, Orbit	500	360
Power Paint Roller	120	90
Power Plane	600	450
Router	900	700
Saw, Circular 6 1/2 in.	2200	1000
Saw, Circular 7 1/4 in.	2500	1200
Saw, Table 10 in.	4000	1500
Saw, Sabre (Worm Drive)	2500	1200
Sander, Belt	1500	600
Sander, Finishing	900	360
Screwdriver, Power	1000	530
Shear, 12 gauge	1800	720
Soldering Gun	—	250
Vacuum Cleaner, Wet/Dry	1500	1260
Wrench, Impact 1/2 in.	2000	840

Figure 3-19. Construction Tool Average Wattage Ratings.

NOTE

Motor-driven equipment generally takes 2 to 3 times more the listed running amperage or wattage to start the motor. Always check the tool or motor nameplate to be sure.

Generator Service

General

Under normal conditions, generator service will not be required on a regular basis. If operating under dusty and

dirty conditions, use dry compressed air to blow dust out of the generator at frequent intervals. Do this with the generator set operating and direct the stream of air in through the cooling slots at the end of the generator.

Storage Procedure

If your generator set is to be out of service for a considerable length of time (2 months or more), complete the following steps to preserve the set before placing it in storage.

1. Drain the oil (while hot) from the crankcase then refill with regular grade oil. See Section 3, Oil Selection in this manual.
2. Drain the fuel from the fuel tank to prevent accumulated moisture from mixing with the fuel.
3. Check the engine coolant protection. See Section 3– Cooling System for additional information.
4. Disconnect battery (negative lead first) and place in storage.
5. Seal all openings in the engine with non-absorbent adhesive tape. Mask off all areas to be used for electrical contact.
6. Clean exterior surface of the generator. Spread a light film of oil over unpainted metallic surfaces which could rust or corrode.

Notes

Section 4. Troubleshooting

When troubles occur, do not overlook simple causes. A starting problem, for example, could be caused by incorrect fuel or an empty fuel tank. The following charts list some common problems. If procedures in this manual do not explain how to correct the problem, take

the generator set to an authorized Kohler service distributor/dealer. Tell the dealer exactly what happened when the problem occurred and of any adjustments made to the set.

Engine

Problem	Possible Cause	Corrective Action
Engine hard to start or will not start	Weak or dead battery	Recharge or replace
	Battery connections made in reverse	Correct
	Faulty ground	Clean and retighten
	Fuse blown	Replace
	Out of fuel	Replenish
	Incorrect type of fuel	Use correct type of fuel; consult fuel and engine supplier (see fuel system specification)
	Fault shutdown	Check low oil pressure and high water temperature shutdown switches
	Clogged fuel filter	Replace filter element
	Air cleaner clogged	Clean or replace element
	Defective fuel feed pump	Replace fuel feed pump
	Air in fuel system	Bleed air from fuel system
	Incorrect type of crankcase lube oil	Use correct lube oil (see oil selection)
	Water, dirt in fuel system	Drain, flush fuel system and replace fuel
	Dirty or faulty injectors	See authorized service distributor/dealer
	Incorrect compression	See authorized service distributor/dealer
	Injection pump malfunctioning	See authorized service distributor/dealer
Incorrect valve clearance	See authorized service distributor/dealer	
Engine knocks	Faulty injector	See authorized service distributor/dealer
	Incorrect type of fuel	Use correct type of fuel; consult fuel supplier (see fuel specifications)
	Incorrect fuel injection timing	See authorized service distributor/dealer
	Incorrect cylinder top clearance	See authorized service distributor/dealer
	Defective piston or piston ring	See authorized service distributor/dealer
	Defective crankshaft bearing or piston pin bearing	See authorized service distributor/dealer
	Incorrect valve clearance	See authorized service distributor/dealer
	Air in injectors	Bleed air in fuel system

Engine (continued)

Problem	Possible Cause	Corrective Action
Engine runs irregularly or stalls frequently	Vent in fuel tank cap obstructed	Clean cap in solvent; blow dry
	Clogged fuel filter	Replace fuel filter element
	Water, dirt, or air in fuel system	Drain, flush, fill, and bleed air in fuel system
	Dirty or faulty injectors	See authorized service distributor/dealer
	Faulty governor linkage	See authorized service distributor/dealer
	Defective fuel feed pump	Replace fuel feed pump
	Incorrect valve clearance	See authorized service distributor/dealer
	Incorrect compression	See authorized service distributor/dealer
Stops suddenly	Out of fuel	Replenish fuel supply
	Air intake restriction	Service air cleaner
	Fuse blown in controller	Replace fuse. If fuse blows again, see authorized service distributor/dealer
	High water temperature (HWT) shutdown*	Check engine coolant level, loose fan belt, radiator obstructions, etc.
	Low oil pressure (LOP) shutdown*	Check engine lube oil level
	Defective fuel pump	See authorized service distributor/dealer
	Clogged fuel filter	Replace filter
Lack of engine power	Engine overload	Reduce load
	Air intake restriction	Service air cleaner
	Clogged fuel filter	Replace filter element
	Incorrect valve clearance	See authorized service distributor/dealer
	Dirty or faulty injectors	See authorized service distributor/dealer
	Incorrect fuel injection timing	See authorized service distributor/dealer
	Incorrect engine compression	See authorized service distributor/dealer
	Vent in fuel tank cover obstructed	Clean cap in solvent; blow dry
	Overfueling (rich)	See authorized service distributor/dealer
Engine overheats	Engine overloaded	Reduce load
	Defective cooling system	Check water pump
	Loose or defective water pump v-belt	Adjust belt tension or replace belt
	Cooling system needs flushing	Flush cooling system
	Defective thermostat	Replace thermostat
	Defective high water temperature (HWT) switch	Replace switch
	Cooling water leaks from passages	Check water passages
	Radiator clogged with dirt or oil	Clean with water soluble grease remover and flush cooling system
	Radiator cap defective	Replace
	Cylinder head gasket defective	See authorized service distributor/dealer
* See Section 2– Fault Shutdowns		

Engine (continued)

Problem	Possible Cause	Corrective Action
Engine emits black or gray exhaust smoke	Fuel filter clogged	Clean or change
	Overload	Reduce load
	Incorrect type of fuel	Use correct fuel
	Clogged or dirty air cleaner	Service air cleaner element
	Defective injection pump	See authorized service distributor/dealer
	Faulty injectors	See authorized service distributor/dealer
	Incorrect fuel injection timing	See authorized service distributor/dealer
	Incorrect valve clearance	See authorized service distributor/dealer
	Lube oil level too high	Drain out surplus
	Incorrect lube oil	Use correct viscosity (see Oil Selection)
Engine emits white or blue smoke	Excessive engine oil	Reduce to specified level
	Piston ring and liner worn	See authorized service distributor/dealer
	Incorrect injection timing	See authorized service distributor/dealer
	Incorrect compression	See authorized service distributor/dealer
Low lube oil pressure	Low lube oil level	Add lube oil
	Incorrect lube oil viscosity	Drain, fill with correct viscosity oil
	Defective lube oil pump	See authorized service distributor/dealer
	Defective oil pressure switch	Replace switch
	Worn engine components	Rebuild— consult engine service manual
High lube oil consumption	Too light viscosity oil	Use correct viscosity oil (see oil selection)
	Oil leaks	Check for leaks in lines, around gaskets, and drain plug
	Incorrect type of oil	Use oil of correct viscosity
	Clogged breather system	Clean breather system
	Defective piston ring, piston cylinder liner, valve guide, or valve seat	See authorized service distributor/dealer
High fuel consumption	Incorrect type of fuel	Use correct fuel (see Fuel Specifications)
	Clogged or dirty air cleaner element	Service air cleaner element
	Engine overloaded	Reduce load
	Incorrect valve clearance	See authorized service distributor/dealer
	Incorrect fuel injection timing	See authorized service distributor/dealer
	Low engine temperature	Check thermostat
	Incorrect compression	See authorized service distributor/dealer
	Fuel leakage	Check for leaks at fuel tank, lines, and engine fuel system

Electrical System

Problem	Possible Cause	Corrective Action
Battery will not charge	Loose or corroded connections	Clean and tighten connection
	Sulfated or worn-out battery	Check electrolyte level and specific gravity (batteries with filler caps only)
	Defective alternator	Replace alternator
	Loose or defective alternator belt	Adjust belt tension or replace belt
Starter does not work correctly	Loose or corroded connections	Clean and tighten connection
	Low battery output	Check electrolyte level and specific gravity (batteries with filler caps only)
	Defective starter solenoid	Replace starter solenoid
	Defective starter switch	Replace starter switch
	Defective wiring	Check wiring
Starter cranks slowly	Low battery output	Check electrolyte level and specific gravity (batteries with filler caps only)
	Too heavy viscosity lube oil	Use correct viscosity (see Oil Selection)
	Loose or corroded wiring	Clean and tighten loose connections
	High starter current draw	Rebuild or replace starter

Generator

Problem	Possible Cause	Corrective Action
No AC output	AC circuit breaker(s) in OFF position	Reset to ON position
	No DC power to controller	Check battery connections
	Fuse blown	Replace fuse
	AC circuit breaker tripping because of overload on generator set	Reduce load (see Wattage Requirements)
	Short circuit in vehicle circuit causing breaker to trip	Reset. If breaker trips repeatedly, stop generator set and contact authorized service distributor/dealer
	General malfunction such as faulty component or other internal fault	See authorized service distributor/dealer
Low output or excessive drop in voltage	Engine speed too low	See authorized service distributor/dealer
	Generator overloaded	Reduce load
Engine in poor condition		If routine services are performed and condition persists, see an authorized service distributor/dealer

Section 5. Wiring Diagrams

Voltage Reconnection

The reconnection procedure explains voltage reconnections only. Adjust the governor and voltage regulator at time of frequency adjustment.

The following information illustrates the reconnection of 4-lead or 12-lead generator sets. In all cases, follow the National Electrical Code (NEC) guidelines.

Reconnect the stator leads of the generator set to change output phase (12-lead models only) or voltage. Refer to the following procedure and the connection schematics. Follow all safety precautions at the front of this manual and in the text while performing this procedure.

NOTE

Order voltage reconnection decal 246242 from an authorized service distributor/dealer and affix decal to generator set after reconnecting to a voltage different than the nameplate.



Accidental starting.
Can cause severe injury or death.

Disconnect battery cables before working on generator set (disconnect negative lead first and reconnect it last).

Disabling generator set. Accidental starting can cause severe injury or death. Turn generator set master switch to OFF position, disconnect power to battery charger, and remove battery cables (remove negative lead first and reconnect it last) to disable generator set before working on the generator set or connected equipment. The generator set can be started by an automatic transfer switch or remote start/stop switch unless these precautions are followed.

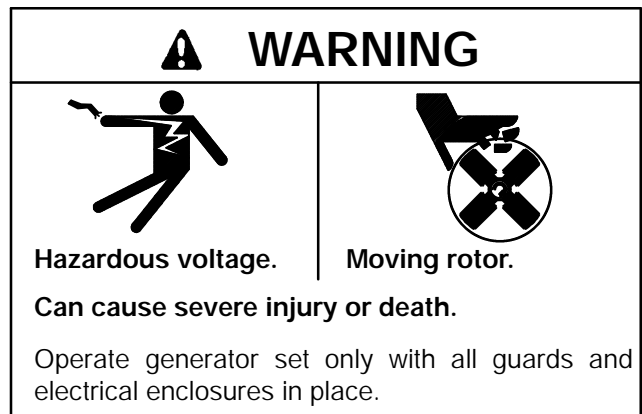

Hazardous voltage.

Moving rotor.

Can cause severe injury or death.

Operate generator set only with all guards and electrical enclosures in place.

Grounding generator set. Hazardous voltage can cause severe injury or death. Electrocutation is possible whenever electricity is present. Open main circuit breakers of all power sources before servicing equipment. Configure the installation to electrically ground the generator set and electrical circuits when in use. Never contact electrical leads or appliances when standing in water or on wet ground, as the chance of electrocution is increased under such conditions.

Short circuits. Hazardous voltage can cause severe injury or death. Short circuits can cause bodily injury and/or equipment damage. Do not contact electrical connections with tools or jewelry while adjustments are made. Remove wristwatch, rings, and jewelry before servicing equipment.

Voltage Reconnection Procedure

Four-Lead (Single-Phase) Generator Sets

See Figure 5-1 for four-lead reconnectable (single-phase) generator set options.

	60 Hz	50 Hz
120/240 or 100/200 volt	X	
110/220 or 100/200 volt		X

Figure 5-1. Four-Lead, Single-Phase Generator Set Voltage Connection Options

120/240-Volt (or 110/220-Volt, 100/200-Volt) Configurations

Circuit breaker must be a circuit breaker manufacturer two-pole circuit breaker. Two single-pole circuit breakers do not conform to NEC requirements when supplying a 240-volt (or 220-volt) load. This is true even if they are mechanically attached together. Leads L1 and L2 are different phases and must never be connected together.

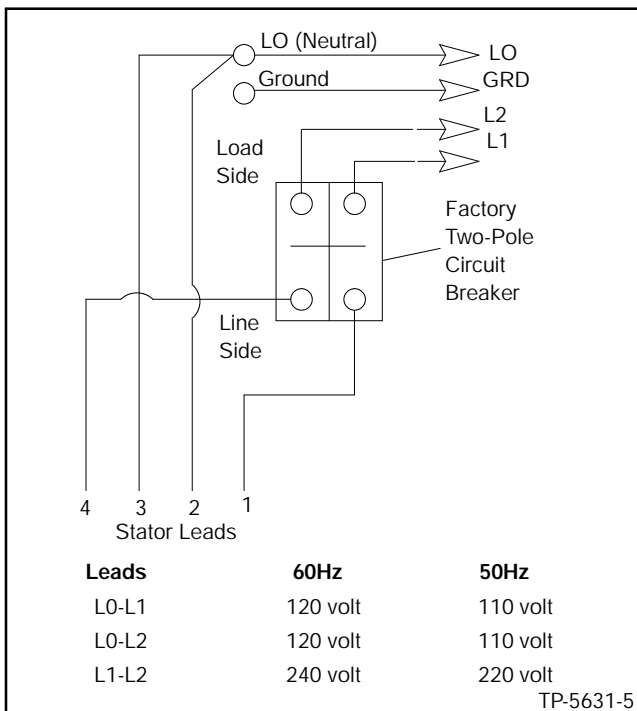

Figure 5-2. 100-120 Volt, 3 Wire Configurations

200-240-Volt Configurations

This system uses a single-pole circuit breaker with 200-240 Volt, 2 wire.

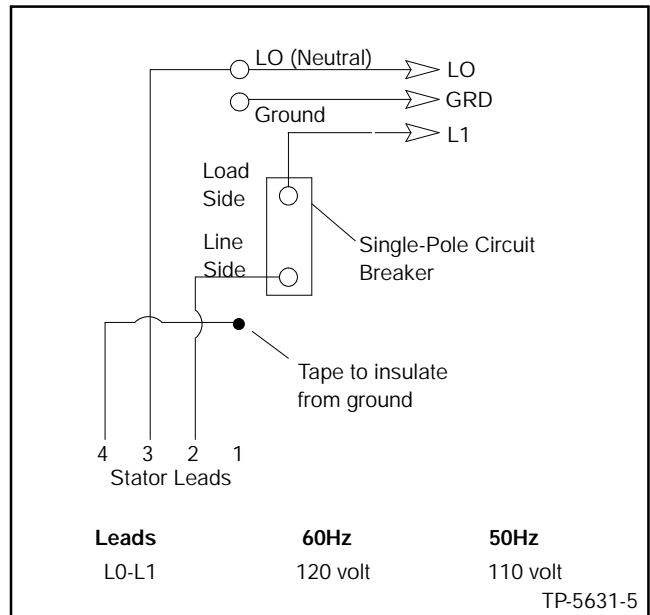

Figure 5-3. 100-120 Volt, 2 Wire Configurations

12-Lead (Three-Phase) Generator Sets

Reconnect three-phase, 12-lead generator sets to the voltages and phases shown in Figure 5-4. If the generator set is reconnected to obtain a different output

voltage, voltage regulator voltage adjustments may be necessary to obtain desired voltage.

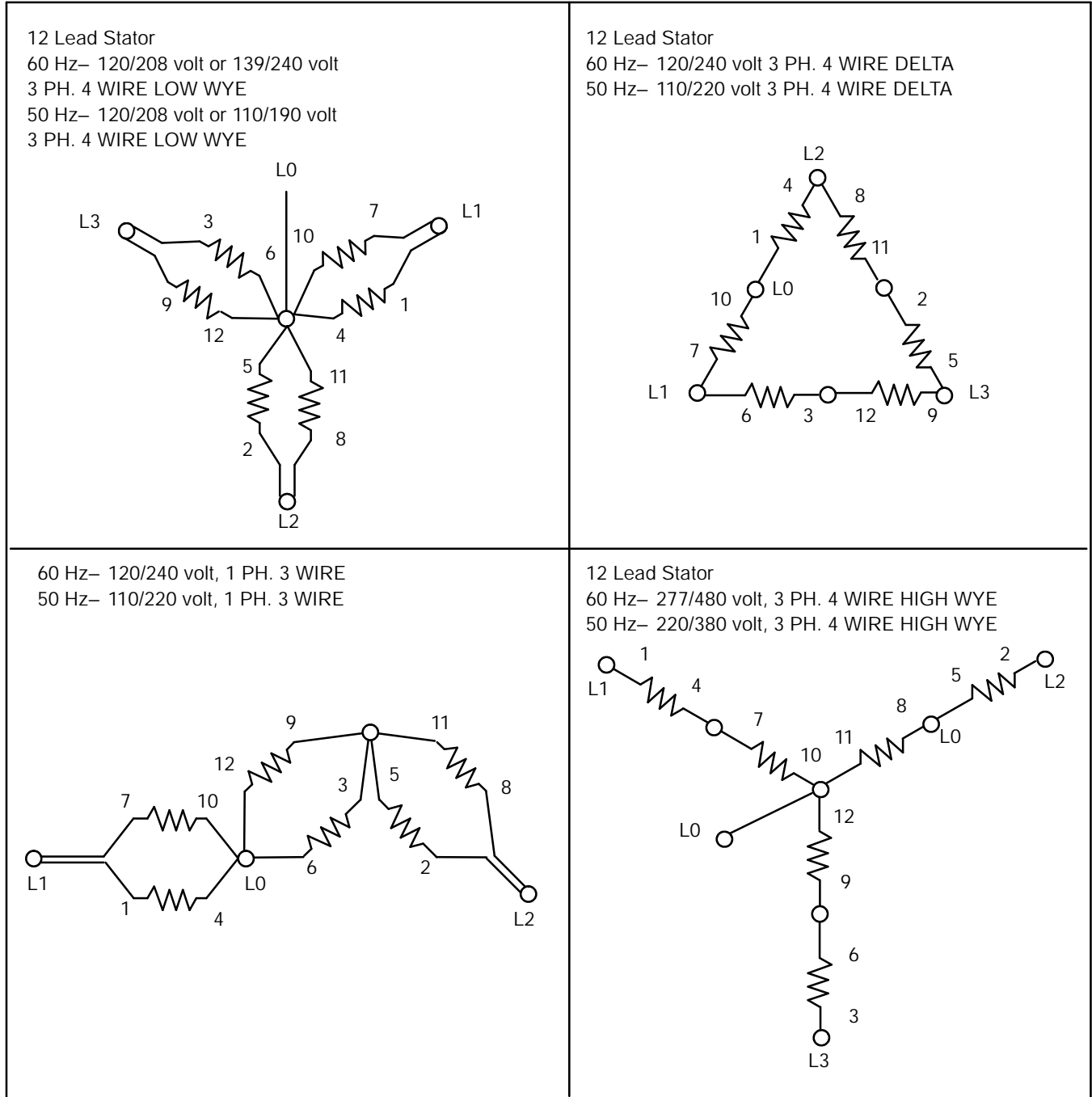

Figure 5-4. Generator Reconnection

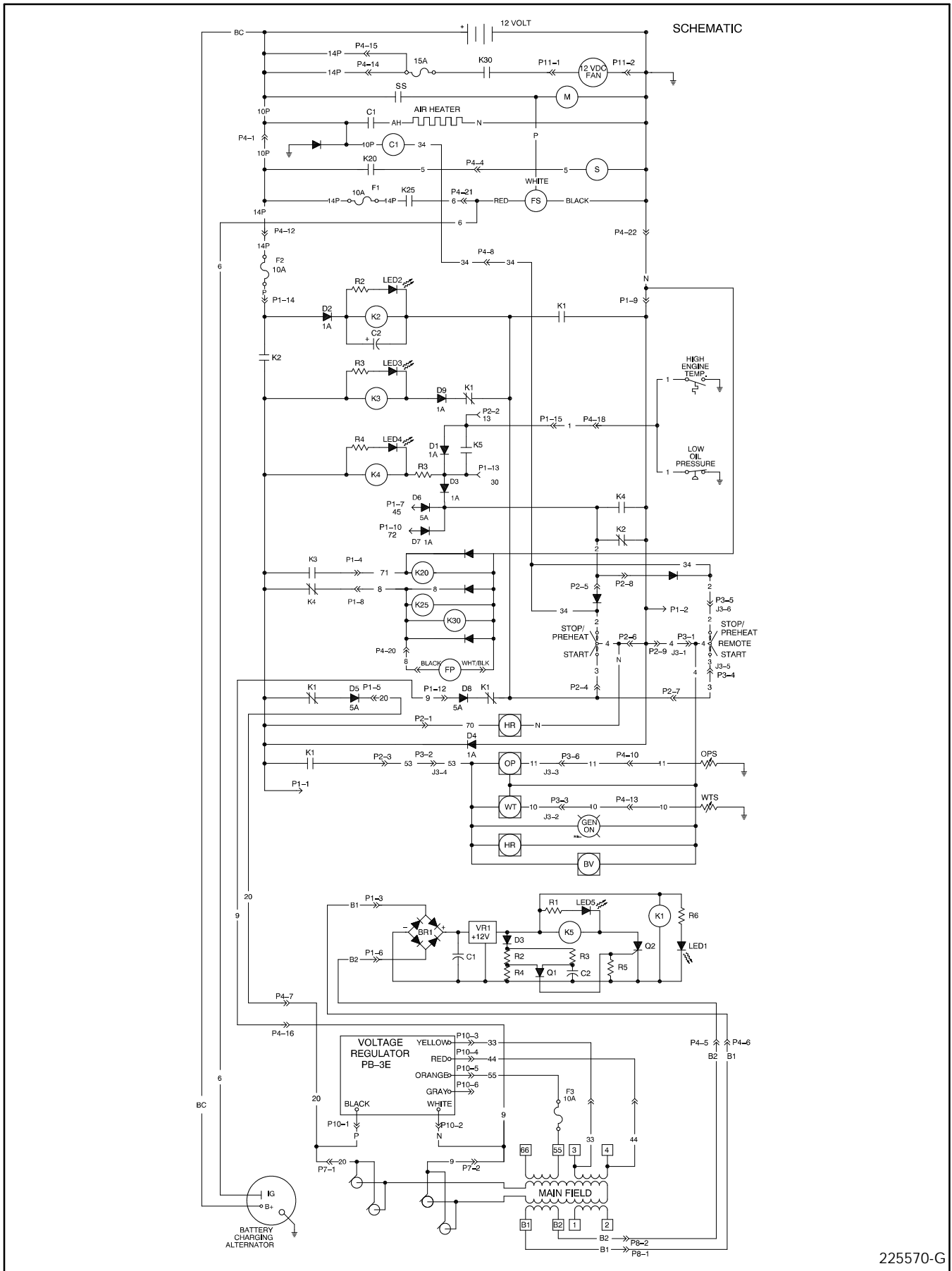

Figure 5-5. Wiring Diagram (Schematic) for 15/20CCO RV Single Phase

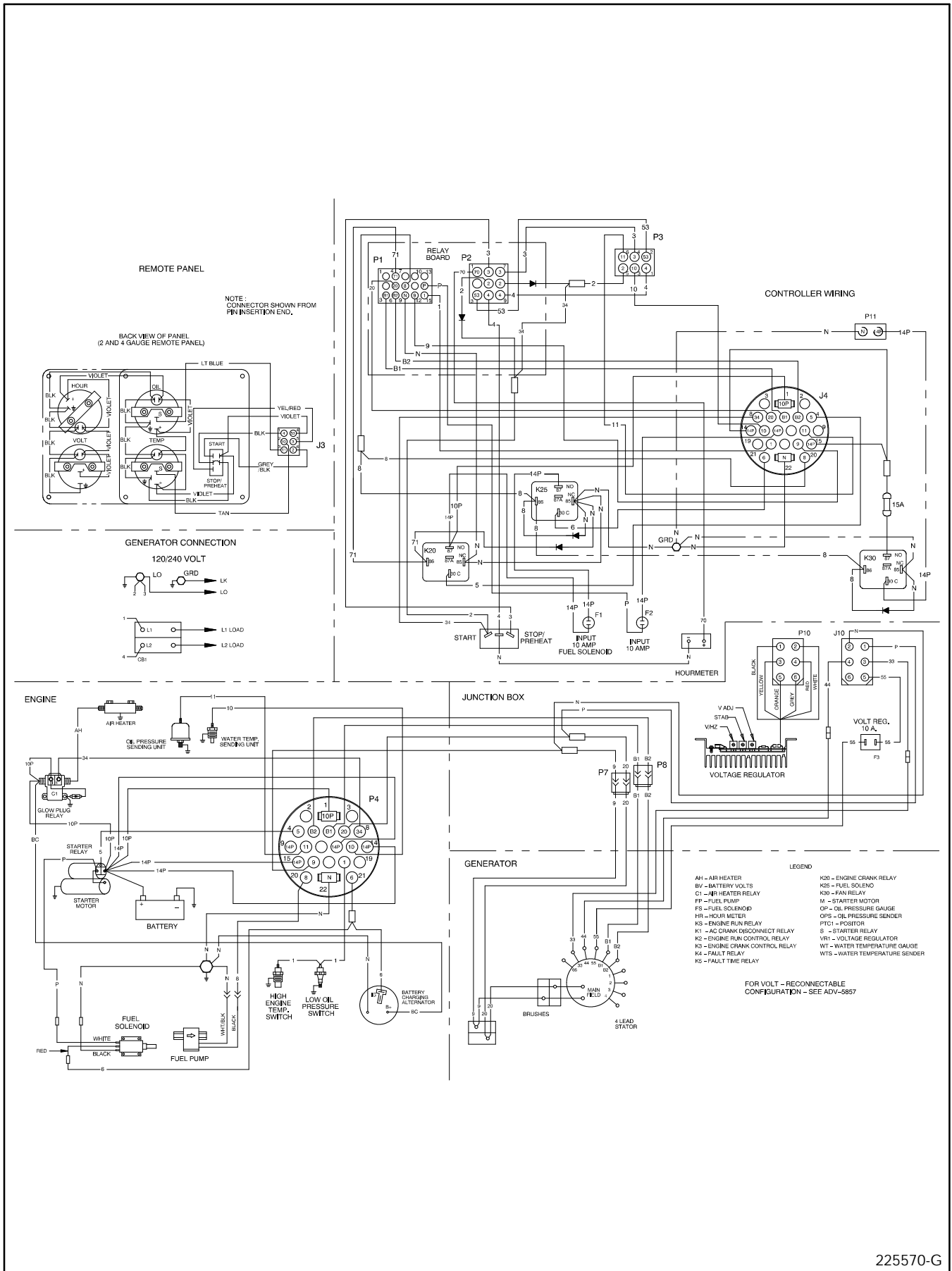

Figure 5-6. Wiring Diagram (Point-to-Point) for 15/20CCO RV Single Phase

225570-G

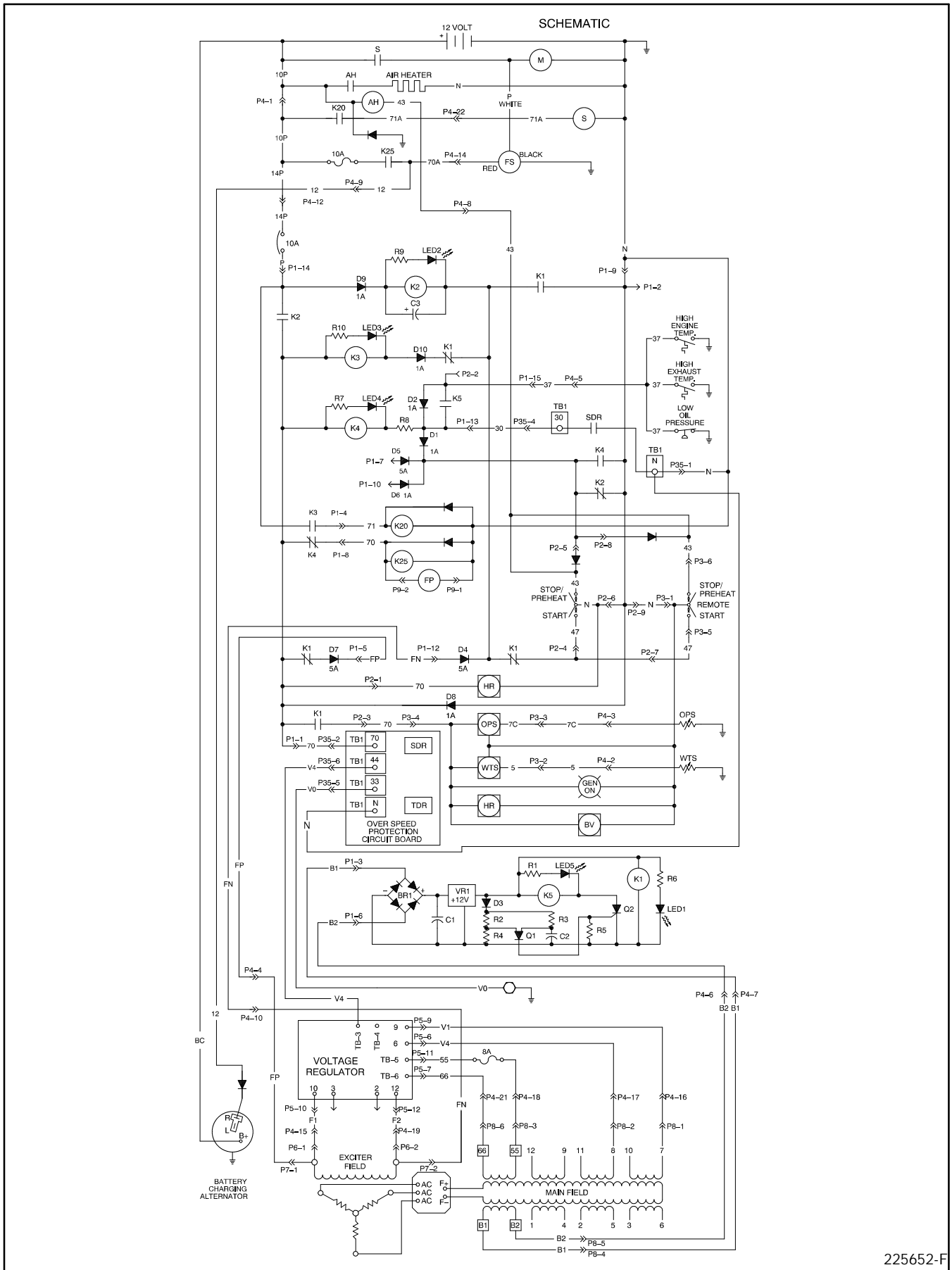
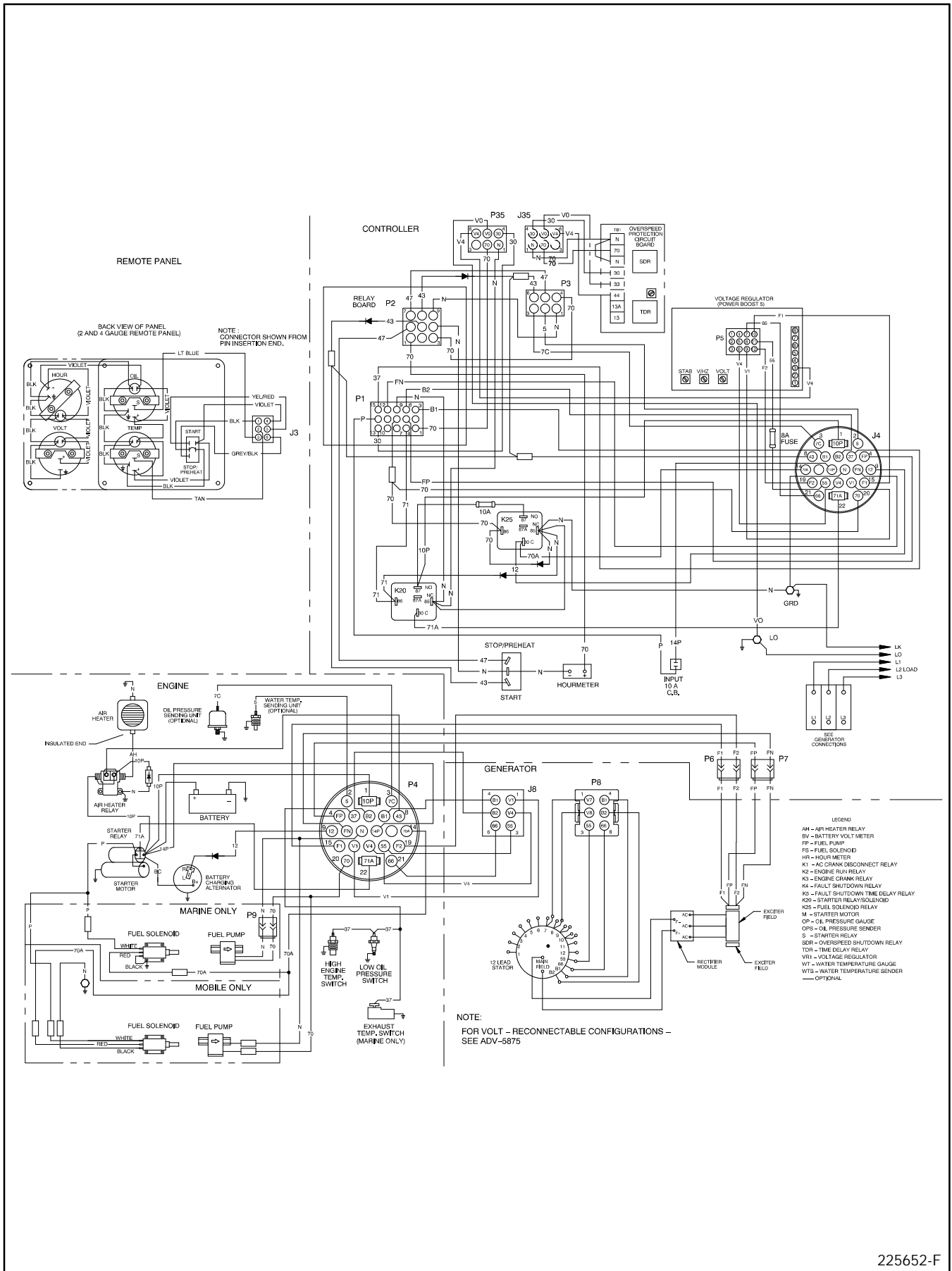
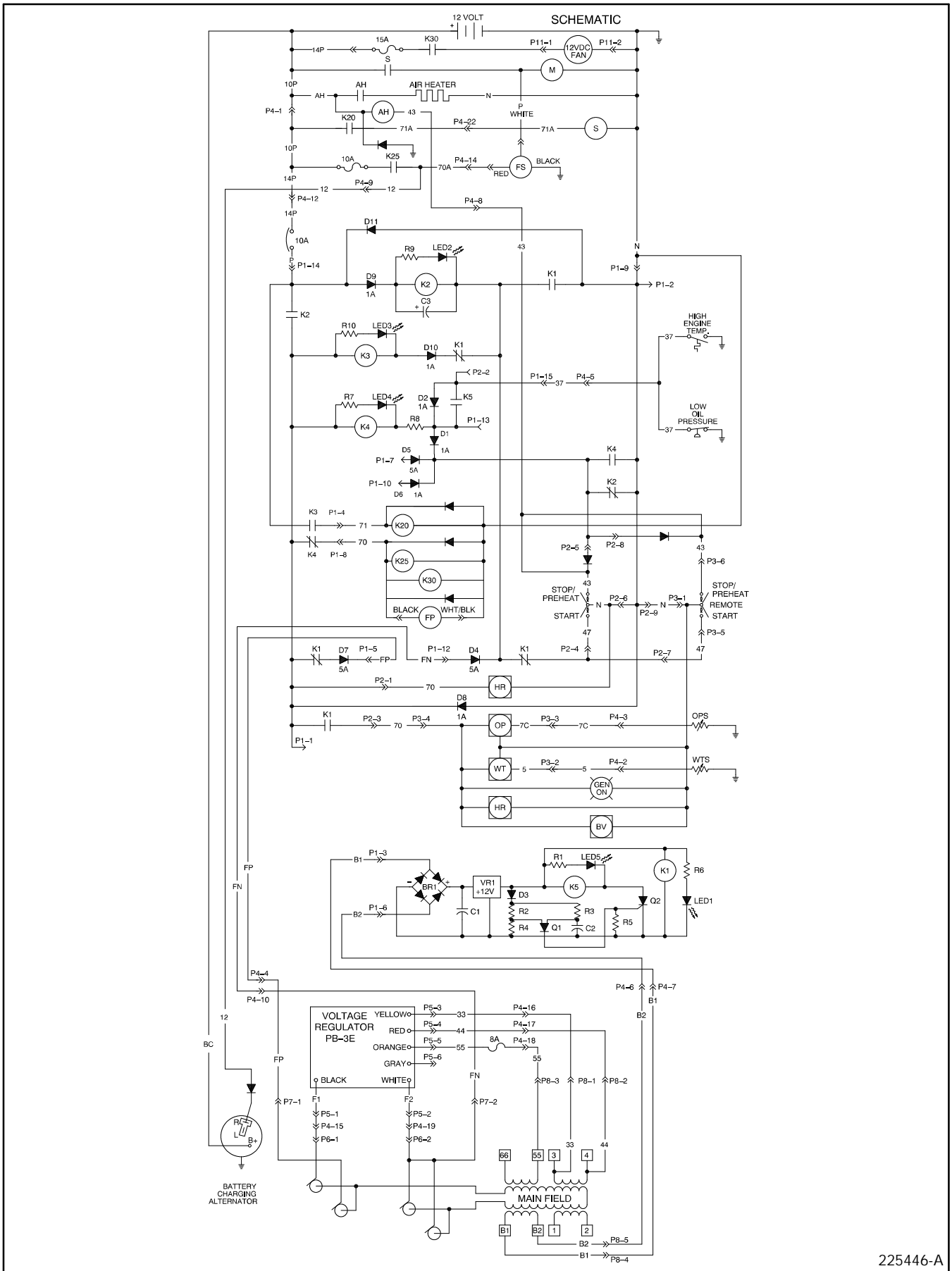

Figure 5-7. Wiring Diagram (Schematic) for 15/20CCOZ Mobile Three Phase



225652-F

Figure 5-8. Wiring Diagram (Point-to-Point) for 15/20CCOZ Mobile Three Phase



225446-A

Figure 5-9. Wiring Diagram (Schematic) for 20CCO RV (spec PA-135322)

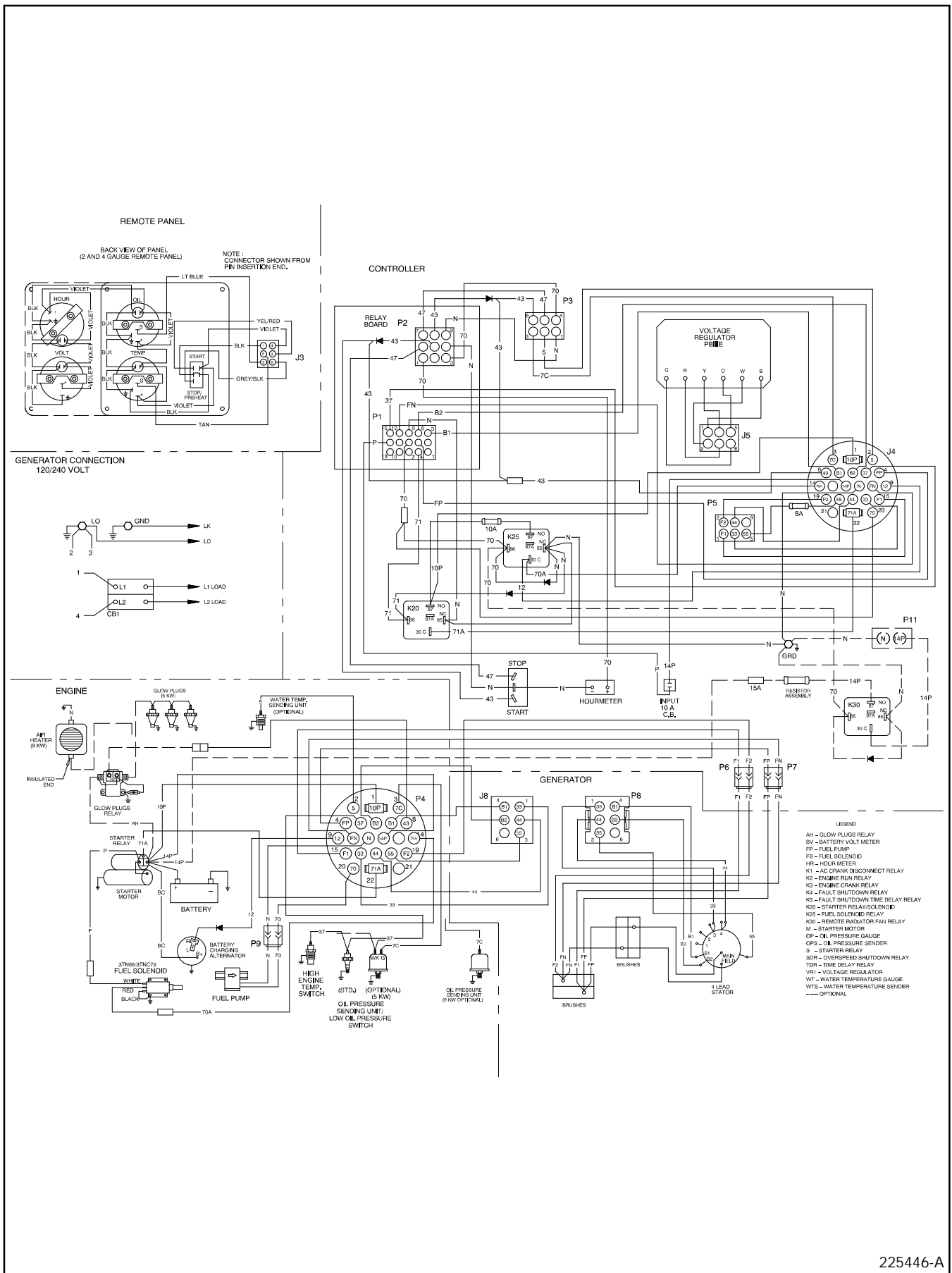

225446-A

Figure 5-10. Wiring Diagram (Point-to-Point) for 20CCO RV (spec PA-135322)

Notes

Section 6. Installation

Introduction

Use this section as a guide when installing a generator set in the vehicle; then refer to the operation section for specific service instructions. When installing an RV/Mobile generator set, the installation must comply with the Kohler-detailed installation instructions. Any additional requirements can also be found in the following sources: (1) ANSI A 119.2/NFPA 501 C, (2) article 551 of ANSI/NFPA 70, National Electrical Code, (3) C.S.A. (Canadian Standards Association) standard C22.2 #100, and (4) C.E.C. (Canadian Electrical Code) C22.1. Generator set installation must also comply with state and local requirements.

NOTE

These generator sets do not comply with United States Coast Guard (U.S.C.G.) requirements and must not be used for marine applications. Use only generator sets specified for marine use in marine installations. U.S.C.G. Regulation 33CFR183 requires a generator set to be ignition protected when used in a gasoline-fueled environment.

Features

These generator sets feature Yanmar 4TN84E-RK or 4TN84TE-RK diesel engines, rotating-field, alternating-current generator, and relay controller. The generator is directly connected to the engine for permanent alignment. Each controller includes a Start-Stop/Preheat switch for test operating the set at the controller. The single-phase controller also has a keyed connector for connecting a wiring harness to a remote start-stop switch (usually located on the dashboard of the vehicle). After the set is attached to the frame of the vehicle and the coach-supplied radiator and hose connections are installed, the following are all that is usually required to make it operational:

- Attach exhaust system.
- Add proper amount of radiator coolant. Mount the coolant recovery tank.
- Add oil to crankcase until dipstick indicates full.
- Connect fuel lines (inlet and return), remote switch, load leads, and battery terminals.

Generator Selection And Wattage Requirements

Consider total wattage requirements (lights, motors, appliances) in selecting a generator set, or sizing wattage requirements when available space and construction may limit the size of the generator set. Refer to the following when figuring wattage requirements.

Installation Factors

Each generator set is shipped as a unit except for the optional exhaust system components which are shipped loose for assembly after the set is installed in the vehicle.

When preplanning the installation, consider the following factors.

1. **Electrical Load:** Does the set selected have adequate capacity to handle the load?
2. **Compartment Size:** Will there be sufficient room around the set to maintain minimum clearances?
3. **Air Requirements:** Are the compartment air inlets and outlets sized to allow adequate circulation of air for cooling and combustion?
4. **Compartment Floor:** Is the compartment floor strong enough to support the weight of the generator set?
5. **Cooling System:** Is the cooling system large enough to adequately cool the generator set?
6. **Fuel System:** Is the system properly designed to prevent fuel starvation of either the main engine or generator set engine?
7. **Exhaust System:** Will the system meet all safety requirements after installation?
8. **Electrical Connections:** Will all systems (battery, load, and remote switch) be compatible with vehicle systems?

Each of these installation considerations is covered in detail on the following pages.

Electrical Load

While the electrical load of the vehicle should have been calculated prior to purchase of the generator set, recheck the load before installing the set to make sure that the capacity is ample to meet demands without possible overloading.

Lighting Load

The lighting load is usually easiest to calculate. In most cases, simply add the wattage of each lamp to be operated off the generator set. Note that in many applications, not all of the lights or lamps are in the generator set AC circuit— some are DC powered by the 12-volt battery in the vehicle. Make sure the total wattage includes only lights actually on the generator set AC circuit.

The lighting load is usually not too heavy in mobile installations; however, it must be accurately calculated to prevent overloading which could occur, for example, if all lights happened to be on when the air conditioner or other motor loads startup.

Motor Loads

When figuring generator set capacity requirements for installation involving motor loads, do not overlook the high current demanded by the motor during startup. The in-rush or starting current may be 2-5 times higher than that required when the motor reaches normal operating speed. Reserve capacity must be allowed for in-rush demands plus other loads which could be on the line as the motor starts.

Air conditioning units are perhaps the most common type of motor load for generator sets in recreational vehicles. The starting characteristics of the different makes of air conditioners vary greatly— one particular 13,500 BTU unit has, for example, lower starting requirements than an 11,000 BTU unit of another make. When only one unit is involved, there is usually no starting problem, provided the lighting and appliance load is not too high when the unit is started.

The trend seems to be toward larger capacity air conditioners and the use of more than one unit in larger vehicles. Simultaneous starting of two units can present problems if the capacity is marginal. Because of the variation in starting characteristics of the various makes of air conditioners, no definite statements are made in this publication regarding multiple motor-starting capabilities of the mobile generator sets covered. Delayed starting or use of easy-starting devices on air conditioner units should be considered whenever simultaneous starting of more than one motor is involved. The starting and running requirements of some motor loads common to mobile applications are listed in Figure 6-1. Use this as a guide when selecting generator set capacity requirements involving motor loads.

Motor Requirements	1/4 HP	1/3 HP	1/2 HP	3/4 HP	1 HP	2HP	3HP
Starting (In-Rush)	750	1000	1500	2000	3300	4000	5000
Running Watts	350	400	600	750	1100	2000	3000

Figure 6-1. Motor Requirements

Electrical Appliance	Ratings (Watts)
Blanket	50-250
Blender	600
Dryer, Hair	500-1200
Fan, Air Circulating	25-100
Fan, Furnace	270
Heater, Space	750-1500
Heater, Water	1500
Pan, Frying	1200
Percolator, Coffee	650
Radio	50-100
Television	300-750
Toaster	750-1200

Figure 6-2. Appliance Ratings (60 Hz)

Construction Tools	Motor Starting Watts	Running Watts
Air Compressor (Small)	1500	725
Air Compressor 3/4 hp	4000+	2000
Drill, 1/4 in.	500	250
Drill, 3/8 in.	600	350
Drill, 1/2 in.	800	600
Grinder 1/2 hp	1500	1200
Hammer, Demolition	2000	1800
Hammer, HD Rotary	1500	1200
Paint Sprayer (Airless)	400	240
Polisher, Orbit	500	360
Power Paint Roller	120	90
Power Plane	600	450
Router	900	700
Saw, Circular 6 1/2 in.	2200	1000
Saw, Circular 7 1/4 in.	2500	1200
Saw, Table 10 in.	4000	1500
Saw, Sabre (Worm Drive)	2500	1200
Sander, Belt	1500	600
Sander, Finishing	900	360
Screwdriver, Power	1000	530
Shear, 12 gauge	1800	720
Soldering Gun	-	250
Vacuum Cleaner, Wet/Dry	1500	1260
Wrench, Impact 1/2 in.	2000	840

Figure 6-3. Construction Tool Ratings (60 Hz)

Appliance Loads

Generator sets in recreational vehicles are often used to furnish AC for appliances such as TV, stereo, electric water heaters, etc. With the exception of the resistance-type loads such as the water heater, requirements for appliances are usually low. Such loads must not, however, be overlooked when figuring total requirements. Reserve capacity should be available for anticipated appliance loads to avoid overloading of a set. The average power requirements of some electrical appliances are listed in Figure 6-2 and Figure 6-3.

Kilowatt Derating

All units are rated 1.0 power factor. The kilowatts of the generator set will decrease 3.5% per 1000 ft. (305 m) above 500 ft. (152 m) above sea level. Derate 1% for every 10°F (5.5°C) above 85°F (30°C).

Compartment Size

When planning compartment size requirements, allow the minimum clearances for cooling of the generator set as shown in Figure 6-4.

NOTE

Because the sets are flexibly mounted, the minimum clearances will ensure that the sides of the compartment and the set will not rub while the set is in operation or while the vehicle is in transit.

Front	1 1/2 in. (38 mm)
Side	1 1/2 in. (38 mm)
Top	1 1/2 in. (38 mm)
Rear	1 1/2 in. (38 mm)

Figure 6-4. Minimum Clearance Requirements

NOTE

Minimum clearances are listed for cooling air circulation. Additional clearance is required for routine servicing of the generator set.

Consider the thickness of insulating and sound-deadening material used to line the compartment when planning clearances. If necessary, enlarge the compartment to maintain minimum clearance requirements. Securely fasten the generator set to avoid unwanted movement from vibration and road shock. If the unit is equipped with a mounting tray, the tray is usually supported on the ends by angle iron and has a full door for service access. Use the same number of bolts as mounting holes in the tray to secure the tray to the support structure. Units not equipped with a mounting tray are secured by attaching the generator set mounts directly to the vehicle frame. Skid-mounted units can be either affixed to a tray for tray mounting or attached directly to the vehicle frame by the installer. The generator is easily removed from the coach if a carriage with rollers is incorporated into the support structure. See Figure 6-5. Avoid road splash and the possibility of igniting combustible material beneath the coach by enclosing all unnecessary free space beneath the generator compartment.

When designing the compartment, allow sufficient room for the set to be easily removed when major service is required. See Figure 6-5. Also keep in mind that the compartment door must have air-intake openings having a free area equal to or greater than that specified under Air Requirements following.

Make sure the compartment is vapor tight and completely sealed from the inside of the vehicle to prevent exhaust or other fumes from entering the vehicle.

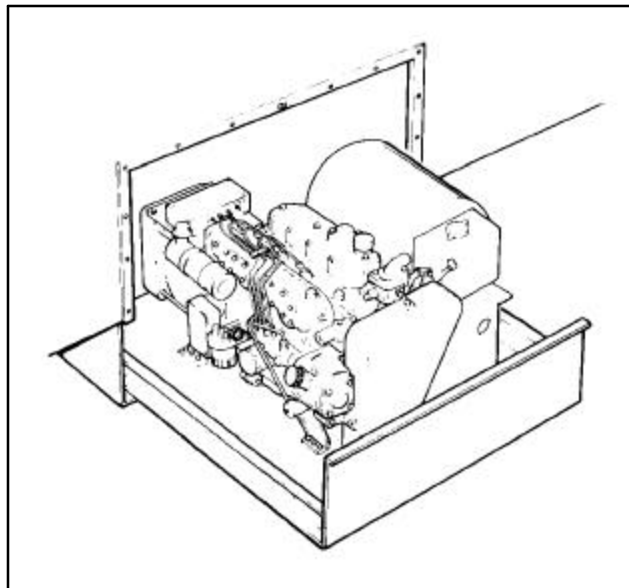

Figure 6-5. Slide Tray Feature for Ease of Service

Line the compartment with a good sound-deadening material. The material selected must be fireproof or highly resistant to fire. An available type of 3-layer foam material does an efficient job of absorbing sound. Some materials have a self-adhesive back; others are easily cut to size with scissors and quickly installed using special fire-retardant adhesive which bonds the material to almost any clean, dry surface.

NOTE

Be careful not to place combustible insulation near exposed exhaust-system components.

Air Requirements

Each engine is equipped with a high water temperature shutdown switch automatically shuts down the set if operating temperatures climb too high. To prevent the generator set from shutdown, make sure the compartment openings are large enough to allow adequate circulation of the cooling and combustion air.

The minimum free-air opening in the compartment is shown in Figure 6-6. Remember louvres, screens, and protective grill work restrict effective air flow. Even a simple, relatively open mesh screen, as shown in Figure 6-7, will restrict air flow as much as 45%. Increase the intake openings to compensate for such restrictions. Air inlet and discharge openings for in-line radiator-mounted models are shown in Figure 6-8 and Figure 6-9.

	Air Inlet	Air Outlet
15 kW Remote Radiator	140 (903)	216 (1393)
15 kW In-line Radiator	430 (2775)	330 (2128)
20 kW Remote Radiator	140 (903)	216 (1393)
20 kW In-line Radiator	430 (2775)	330 (2128)

**Figure 6-6. Min. Air Requirements
sq. in. (sq. cm.)**

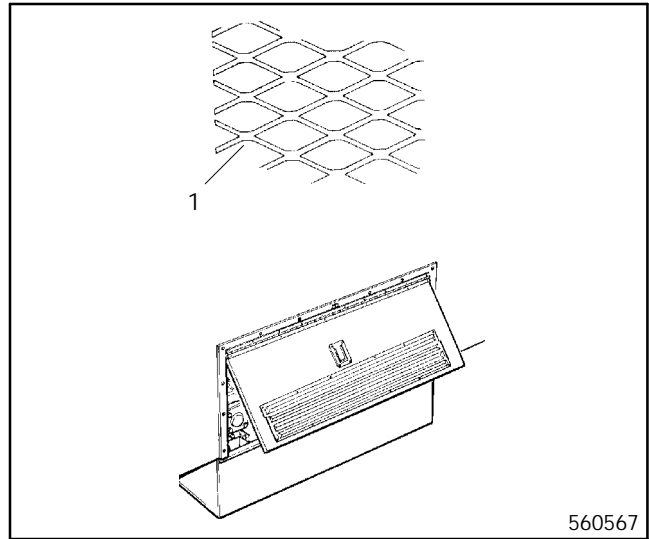

1. Wide mesh screen

Figure 6-7. Inlet Screen

Remote and in-line radiator generator sets will require an air outlet in the compartment floor and an air inlet in the generator-end wall. See Figure 6-11 for proper sizes and positions. An additional 3 in. (7.62 cm) diameter hole is required in the compartment so combustion air from the outside of the compartment can be brought into the air cleaner using a 2 in. (5 cm) I.D. hose.

NOTE

Install two supplemental cooling fans, capable of 265 cfm (7.49 m³/min) each, to supply adequate air to the generator compartment.

NOTE

Seal the air inlet openings, at the engine in-line radiator and/or generator-end bracket, against the compartment wall. This is to make sure that only exterior air is drawn into the generator compartment.

15/20 kW Generator Free-Air Opening: 140 sq. in. (903 sq. cm)

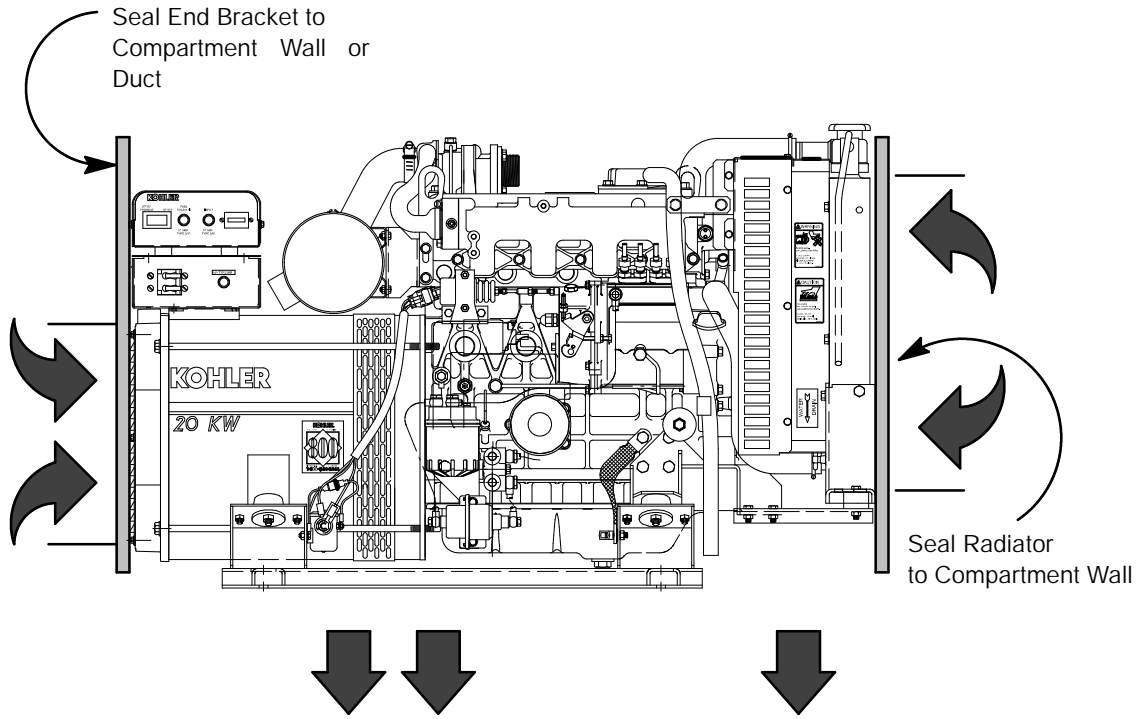

15/20 kW Radiator Free-Air Opening: 290 sq. in. (1872 sq. cm)

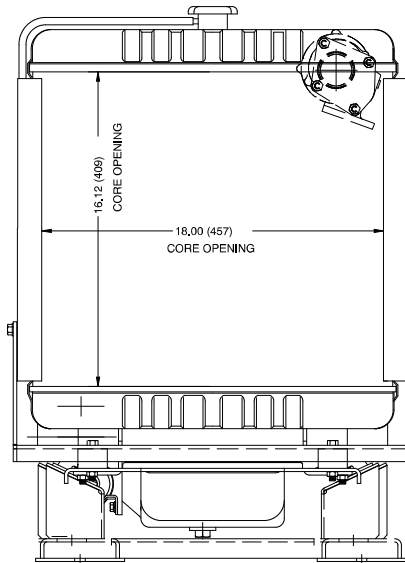

ADV-5834-

Figure 6-8. Air Flow Requirements for In-line Radiator Model with Suction Fan.

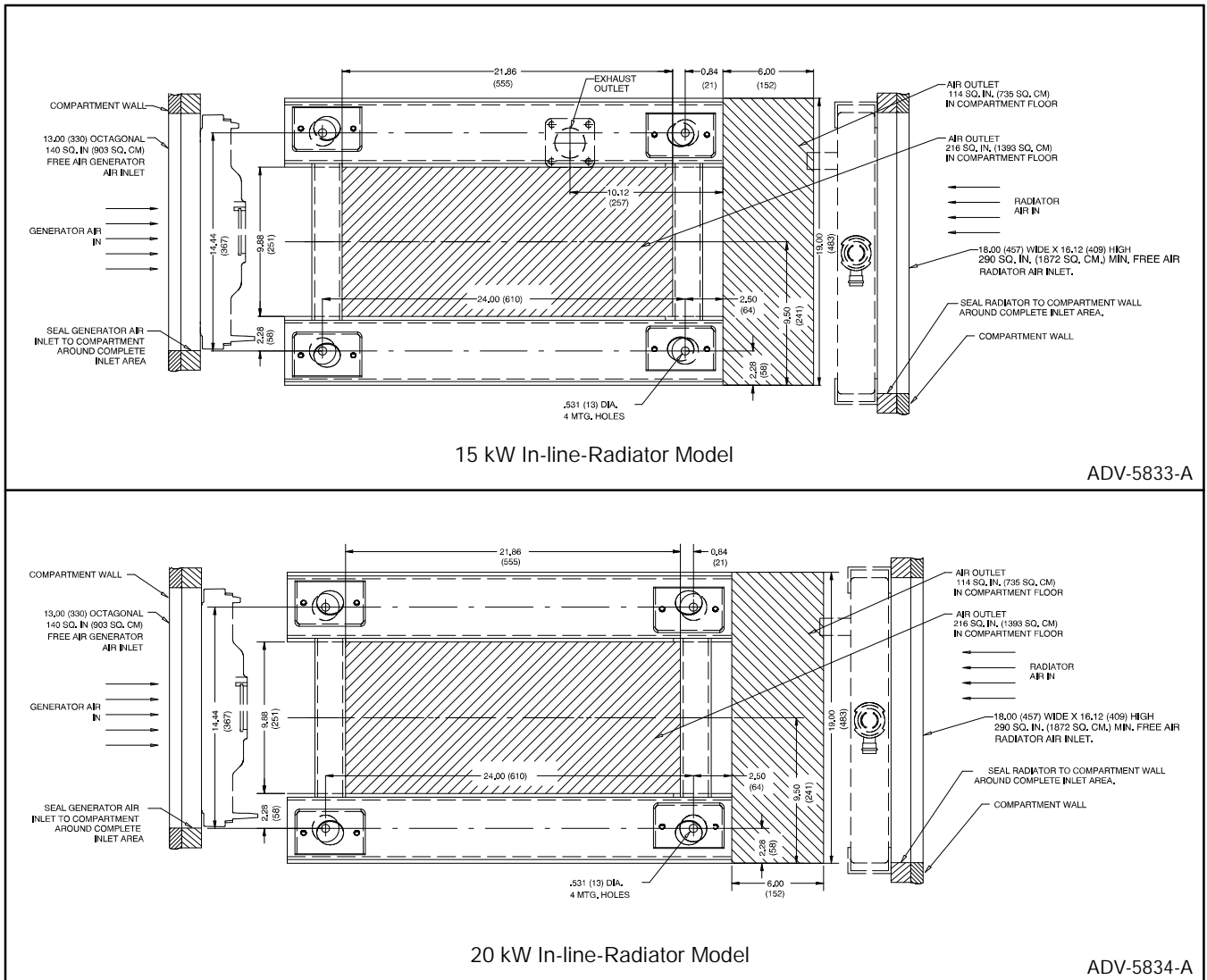

Figure 6-9. Air Flow Requirements for In-line Radiator Models (with Suction Fan)

Remote Radiator Cooling System

Use the following data to design and install the generator set cooling system. To ensure a safe, effective installation, be sure the cooling system selected follows these parameters. Kohler Co. offers radiator assemblies which meet these requirements and adequately cool the generator. Select the radiator assembly appropriate for the generator installation.

Due to the multitude of coach manufacturers and variety of generator installations, only general guidelines are provided. Adapt these recommendations to the installation. In a typical installation, install the radiator assembly the same compartment as the generator. If using the blower fan radiator assembly is used, cooling air is drawn across the generator and engine and then through the radiator. If the suction fan radiator assembly is used, the suction fan pulls cooling air through the radiator and then past the generator set. If the radiator assembly alone is used, the installer must supply an electric blower or suction fan to circulate the cooling air through the radiator. See Figure 6-10 and Figure 6-11. Depending on space limitations, locate the radiator in front of, adjacent to, or in a ventilated location remote from the engine (maximum horizontal distance from the generator is 10 ft.). To prevent recirculation of heated air, be sure to maintain a tight seal between the radiator and the discharge chute. Generally, the discharge chute opening should be approximately 1 1/2 times the size of the radiator core.

NOTE

If locating the radiator in a compartment separate from the engine, remember the engine combustion air and heat rejection requirements of the alternator and engine block when designing the cooling system. Two supplemental cooling fans capable of 265 cfm (7.49 m³/min) should be installed to supply air to the generator compartment for these requirements.

NOTE

If installing a non-Kohler radiator assembly, be sure the radiator fan motor rotates in the correct direction and is of the proper voltage.

If sizing a non-Kohler radiator, follow these general guidelines for radiator selection.

Heat Rejection:

15 kW– 792.99 Btu per min.

20 kW– 1050.58 Btu per min.

Cooling System Water Flow:

Typical: 35 liters per min. at 1800 rpm*

31 liters per min. at 1500 rpm*

Max. water head allowed:

230°F (110°C) ± 3°

Connection Points to Radiator 15/20CCO:

Coolant Inlet: 1.10 in. (28 mm) I.D. Hose

Coolant Outlet: 1.10 in. (28 mm) I.D. Hose

*If the application requires excessive runs between the generator set and the remote radiator, check the water flow. Be certain the radiator is sized accordingly for the installation.

NOTE

The cooling system fill (radiator or coolant recovery tank) must be the highest point in the cooling system. (See Figure 6-12.) If the cooling system fill is not located as directed, cooling water will not completely fill the engine and result in overheating of the engine and disablement of the high water temperature shutdown switch.

A close relationship exists between the cooling system design and the generator compartment size. Availability of space is often the determining factor in cooling system design. See Compartment Size section of this manual prior to designing and installing the generator cooling system.

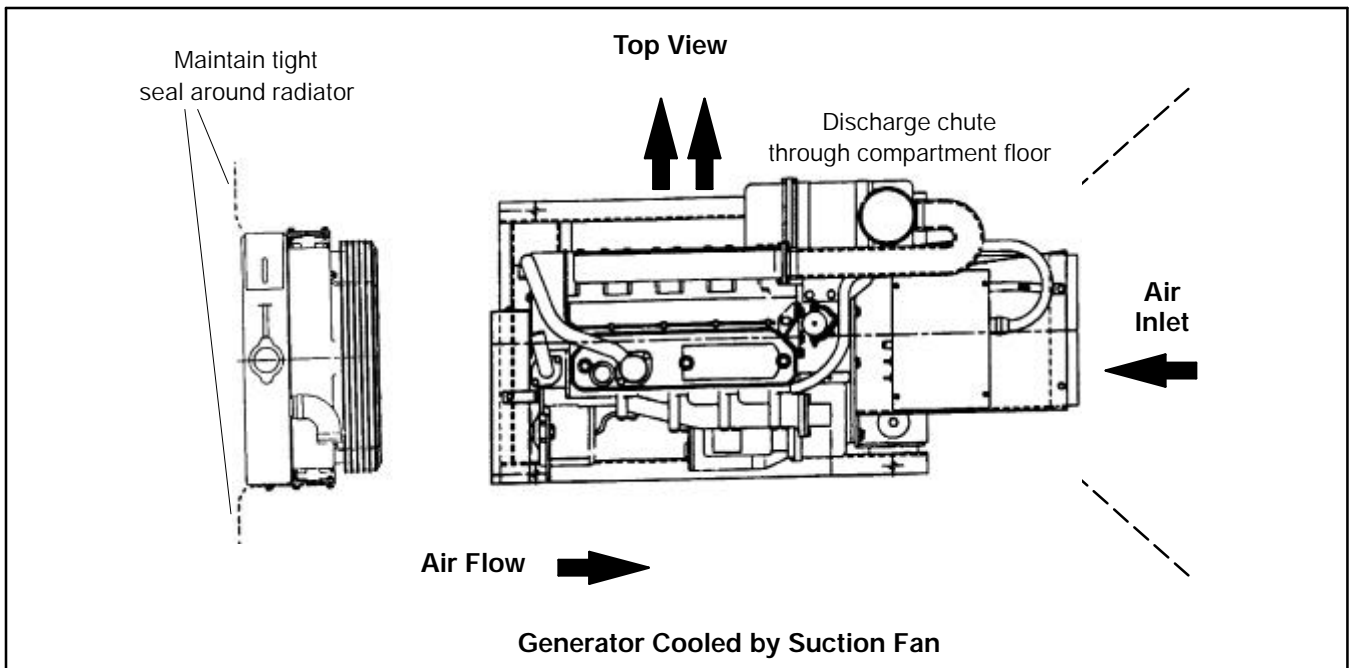

Figure 6-10. Typical Cooling System Installation for Remote Radiator Mounted in the Generator Compartment

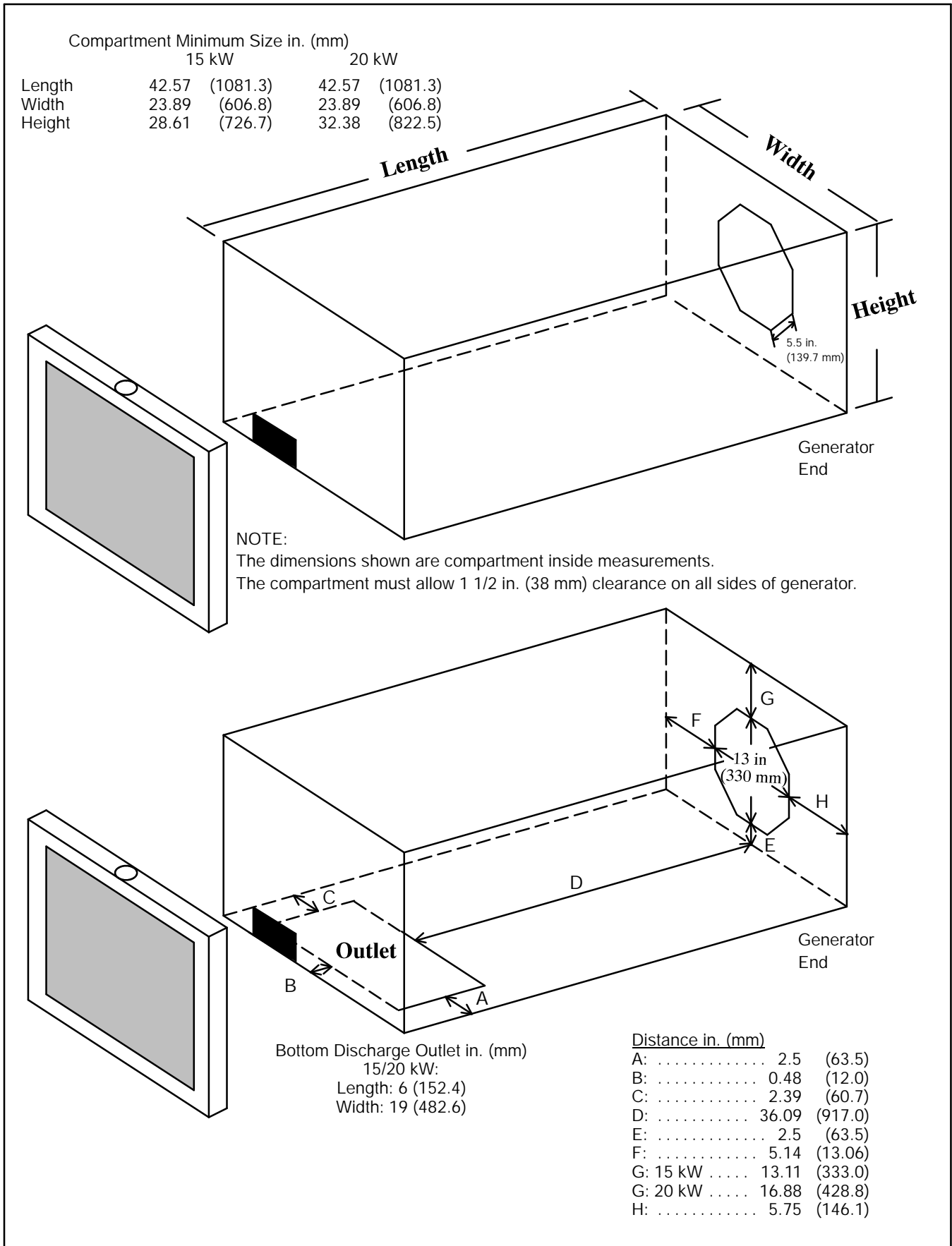
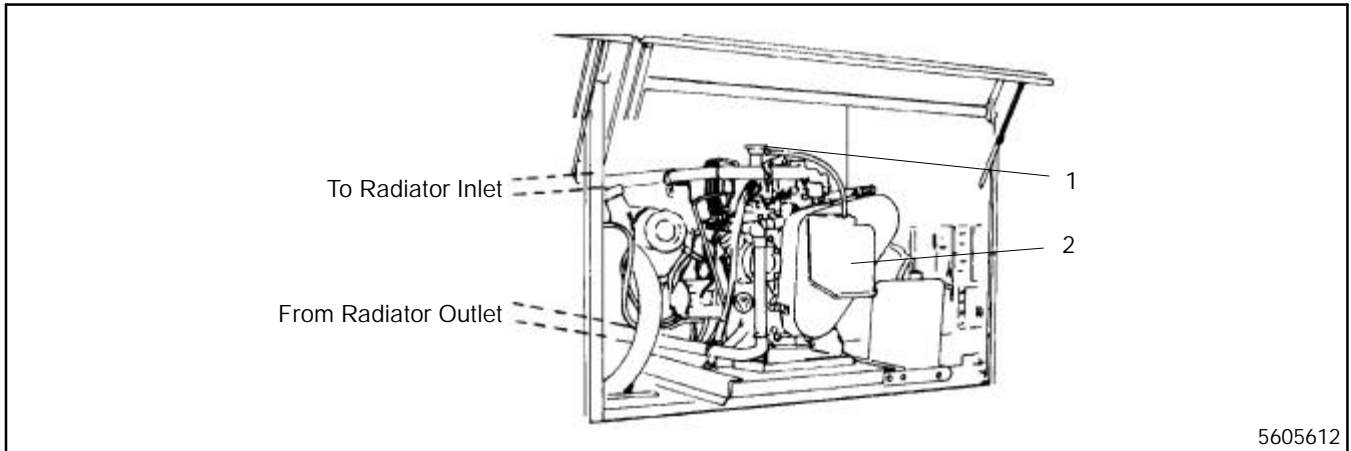

Figure 6-11. Typical Cooling System Installation (Compartment Minimum Sizes) for Remote Radiator Mounted Outside the Generator Compartment

NOTE

Mount the coolant recovery tank so that its surface level is the same height or 2 in. (5 cm) max. below the level of the pressure cap. See Figure 6-12. If the cooling

system fill (coolant recovery tank) is not located as directed, cooling water will not completely fill the engine and result in overheating of the engine.



1. Initial coolant fill

2. Coolant fill at coolant recovery tank

Figure 6-12. Cooling System Fill (Coolant Recovery Tank)

Fuel System

 **WARNING**



**Explosive fuel vapors.
Can cause severe injury or death.**

Use extreme care when handling, storing, and using fuels.

Fuel system. Explosive fuel vapors can cause severe injury or death. All fuels are highly explosive in a vapor state. Use extreme care when handling and storing fuels. Store fuel in a well-ventilated area away from spark-producing equipment and out of the reach of children. Never add fuel to the tank while the engine is running since spilled fuel may ignite on contact with hot parts or from ignition spark. Do not smoke or permit flame or spark to occur near sources of spilled fuel or fuel vapors. Keep fuel lines and connections tight and in good condition. Do not replace flexible fuel lines with rigid lines. Use flexible sections to avoid breakage caused by vibration. Do not operate generator set in the presence of fuel leaks, fuel accumulation, or sparks. Repair systems before resuming generator set operation

Draining fuel system. Explosive fuel vapors can cause severe injury or death. Spilled fuel can cause an explosion. Use a container to catch fuel when draining fuel system. Wipe up all spilled fuel after draining system.

The diesel fuel system for the generator set must be designed to operate independently of the system for the vehicle engine if both engines are to be operated at the same time. The best way to do this is to have separate fuel tanks; however, this is usually impractical because of space restrictions. In most installations, both engines operate off a common tank with a separate dip tube arrangement as shown in Figure 6-13. This prevents the smaller engine from being starved of fuel by the larger engine. The generator set dip tube is generally shorter than the vehicle dip tube. With this arrangement, fuel may not be available to the generator set when fuel supply is low.

A simple tee fitting is sometimes used to provide fuel for both engines off a common tank; however, this usually prohibits simultaneous operation. There is also the possibility that operation of either engine could

completely drain the fuel line of the other engine, thus making starting difficult if not impossible. Therefore, the tee arrangement should not be used.

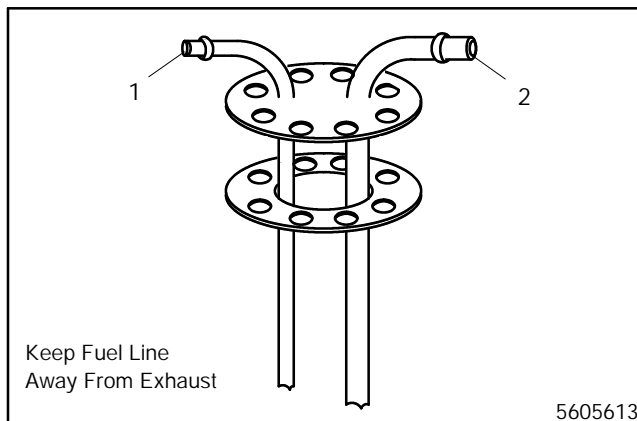

1. Fuel line to generator set
2. Fuel line to vehicle engine

Figure 6-13. Two Dip Tubes in Fuel Tank

NOTE

Do not tee into fuel-injected fuel systems. Use a two dip tube arrangement for fuel supply. Consult an authorized Kohler service dealer/distributor for further fuel system installation information.

Take care when routing the fuel line from the fuel tank to the generator set. Keep fuel lines as short as possible but maintain adequate clearance from the exhaust system. Run fuel lines along the frame or undercarriage— never run fuel lines inside the coach. Locate fuel lines below the generator set compartment with entry point near fuel pump (max. lift of the fuel pump is 1 meter or 39 inches). The fuel line must be of adequate size to handle the flow of fuel and withstand road shock and year-round climate conditions. If using steel tubing, it should be 5/16 in. (8 mm) I.D. (minimum) with an 8 in. (230 mm) (minimum) flexible section to allow free movement of the generator set. Fuel inlet and return connections are 1/4-18 N.P.S.F.

Locate the fuel return line as far as practical from the fuel pickup. This will allow returned fuel to be cooled by the tank fuel before delivery back to the fuel injectors. Incoming fuel cools the injectors and achieves maximum engine efficiency supplying cool fuel to the engine. The fuel tank capacity and the amount of fuel will affect cooling capability.

Fuel Line Sizes:

Fuel Inlet	1/4-18 N.P.S.F.
Fuel Return	1/4-18 N.P.S.F.

Fuel Lines

If using metal lines from the fuel tank, a flexible hose section should connect the metal line to the fuel pump. A flexible hose section should connect the metal line from the fuel tank to the engine fuel-return connection point.

The flexible sections allow vibrational motion of the generator set during operation. See Figure 6-14 for fuel inlet- and return-line connections.

NOTE

Diesel-fueled engines require type B1 hose.

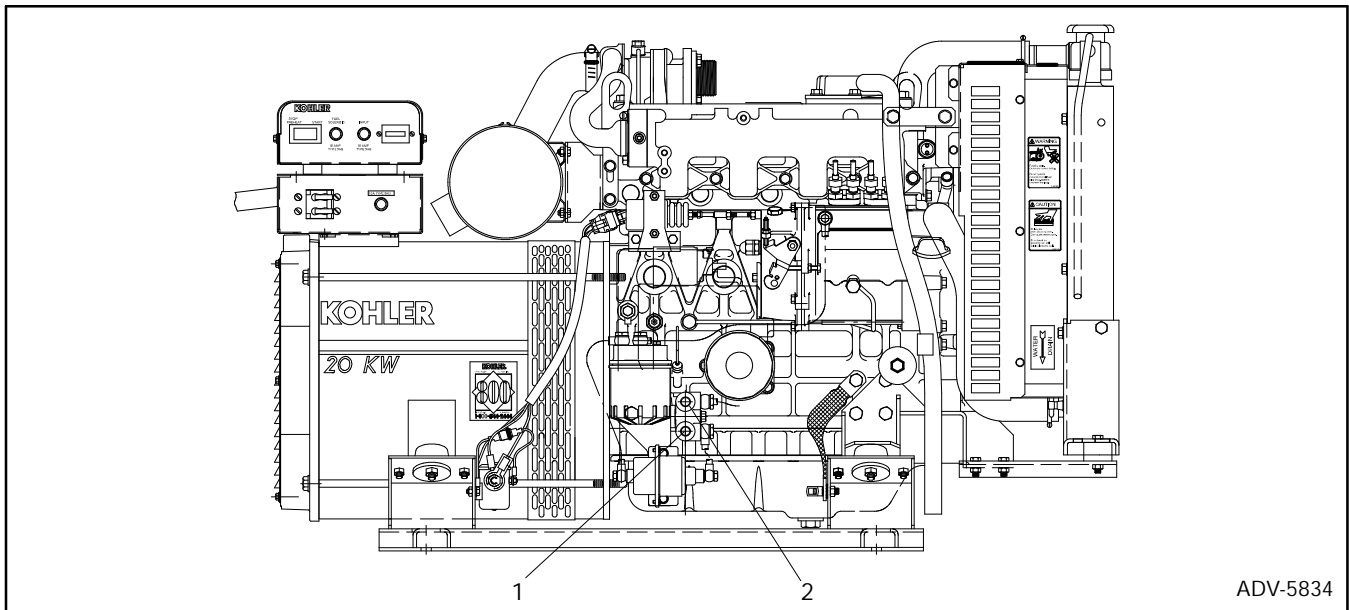



1. Fuel inlet connection

2. Fuel return connection

Figure 6-14. Fuel Inlet and Return Connection Points

Exhaust Systems

Carefully plan the generator exhaust system to ensure a safe, quiet installation. Be sure the installation will comply with all state and local requirements and applicable articles of the codes listed at the beginning of this section.

 WARNING

Hot engine and exhaust system. Can cause severe injury or death. Do not work on generator set until it is allowed to cool.

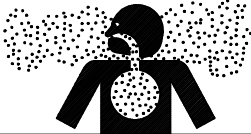
Combustible materials. Fire can cause severe injury or death. Hot exhaust system can ignite adjacent combustible materials. Do not locate electrical wiring, fuel lines, or combustible material above the exhaust muffler. Exercise caution when parking your vehicle to prevent exhaust system and hot exhaust gases from starting grass fires.

 WARNING

Carbon monoxide. Can cause severe nausea, fainting, or death. The exhaust system must be leakproof and routinely inspected.

Installing exhaust tail pipe. Carbon monoxide can cause severe nausea, fainting, or death. Install exhaust system tail pipe so discharged exhaust gases will not be drawn into vehicle interior through windows, doors, air conditioners, etc. Do not use flexible tail piping because it could crack and allow lethal exhaust fumes to enter the vehicle.

Generator set operation. Carbon monoxide can cause severe nausea, fainting, or death. Never operate the generator set inside a building unless the exhaust gas is piped safely outside. Never operate in any area where exhaust gas could accumulate and seep back inside a potentially occupied building or vehicle. Be careful when parking your vehicle to avoid obstructing the exhaust outlet. The exhaust gases must discharge freely to prevent carbon monoxide from deflecting into the vehicle. Avoid breathing exhaust fumes when working on or near the generator set. Carbon monoxide is particularly dangerous because it is an odorless, colorless, tasteless, nonirritating gas that can cause death if inhaled for even a short period of time.

Copper tubing exhaust systems. Carbon monoxide can cause severe nausea, fainting, or death. Do not use copper tubing in diesel exhaust systems. Sulfur in diesel exhaust causes rapid deterioration of copper tubing exhaust systems resulting in exhaust/water leakage.

NOTE

Suspend exhaust system components beneath the undercarriage with automotive-type tailpipe hangers (shock mounted) only. Position hangers in vertical position directly above exhaust pipe to reduce vibration. Excessive vibration caused by angular hanger mounting could cause exhaust pipe damage. If the tailpipe extends more than 18 in. (45.7 cm) beyond muffler, attach an additional hanger for support. Use only automotive-type, U-bolt muffler clamps in exhaust system installation.

NOTE

The muffler material must be aluminized steel or other corrosion-resistant material of welded or crimped construction. The muffler must be a USDA-approved type or the muffler must be fitted with a USDA-approved spark arrestor.

Because of the different locations of mufflers and piping to these mufflers, follow clearance requirements to

protect generator set components and to avoid igniting adjacent combustible materials. A clearance of 1.5 in. (38 mm) is recommended between exhaust system parts and fuel system, electrical system, and all combustible components.

Route the exhaust piping through the compartment floor or walls provided minimum clearances are maintained and exhaust piping bends are minimized. Use a tail pipe as short as possible with as few gradual bends as possible to reduce back pressure; maximum back pressure allowed is 21.65 in. water column for the 15 kW and 11.81 in. water column for the 20 kW. The exhaust piping must include an exhaust sleeve or thimble when routed through a combustible wall. Extend tail pipe a minimum of 1 in. (25 mm) past perimeter of vehicle. If the generator tail pipe is located on the same side as the compartment air intake, position tail pipe so exhaust gases will not be recirculated. Install 1.61 in. I.D. flexible tubing between the exhaust manifold flange and the silencer.

Electrical Systems

Battery, load lead, and remote switch panel connections are needed to complete the installation. Make final connections to the battery only after all other connections have been made as this will prevent unintentional starting. Some specific details on each connection are stated in the following paragraphs. Refer to the wiring diagram for specific details. Connections should be made only by qualified electricians. Securely supported or harness all wiring to the generator set to prevent abrasion. Additional support is required to prevent exposure to the exhaust system and drippage of fuel, oil, or grease— at least 2 in. (51 mm) clearance must be provided between electrical wiring and hot exhaust parts. Also, do not locate wiring directly below or in close proximity to fuel system parts or oil fill tube. Some other points to consider when making AC load connections are covered in the following paragraphs.

NOTE

Wiring connections made at the time of installation should be accessible for inspection and servicing.

Battery And Connections

A separate 12-volt battery is recommended for the generator set. With a separate battery, cables can be kept short which eliminates the problem of excessive voltage drop through long cables. See Figure 6-15 for length and sizes. Refer to Figure 6-16 (View A) for cable connections (note that a ground strap must be connected between the ground lug on the generator set and frame of the vehicle with this arrangement).

If the starting battery for the vehicle engine must also be used for starting the generator engine, the negative battery terminal must be grounded to the vehicle frame and heavy gauge (#4) ground strap must connect the ground lug on the generator set to the vehicle frame as illustrated in Figure 6-16 (View B).

Distance Between Generator Set And Battery	Cable Size (AWG) at 0°F (-18°C)	Cable Size (AWG) at 32°F (0°C)	Cable Size (AWG) at 75°F (24°C)
40 ft. (12.2 m)	0	0	1
30 ft. (9.1 m)	0	1	2
25 ft. (7.6 m)	1	2	4
20 ft. (6.1 m)	2	2	6
15 ft. (4.6 m)	2	4	6
10 ft. (3.0 m)	4	6	8
5 ft. (1.5 m)	6	6	8
2.5 ft. (0.8 m)	8	8	8

Figure 6-15. Battery Cable Size

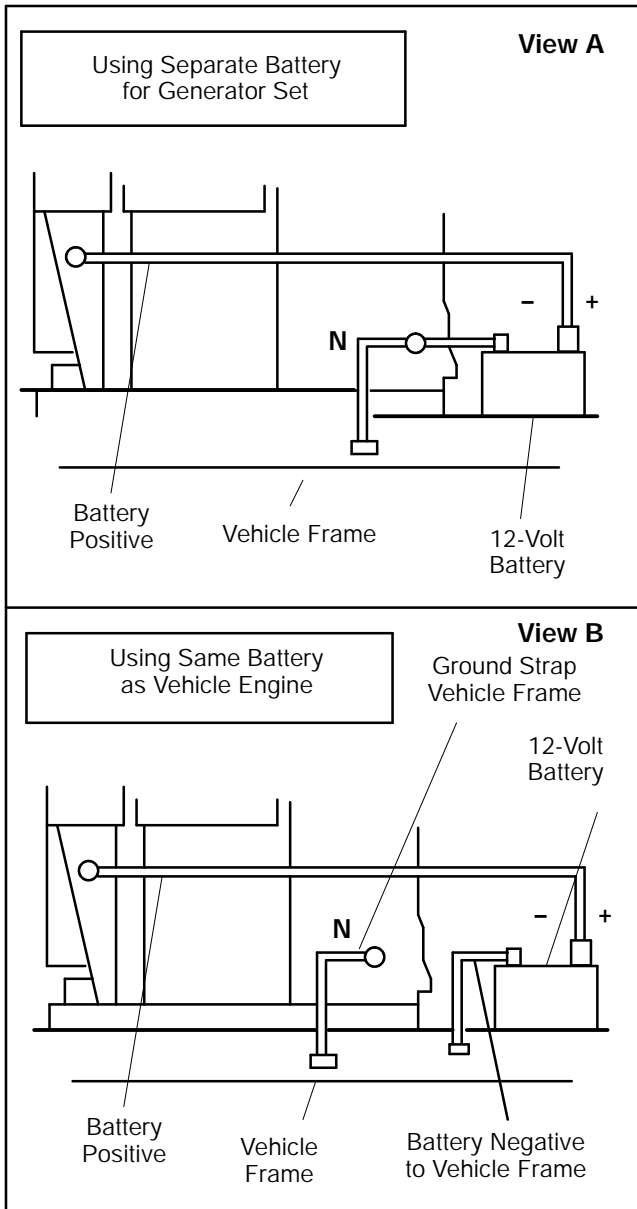

Figure 6-16. Battery Connection Details

⚠ WARNING



**Sulfuric acid in batteries.
Can cause severe injury or death.**

Use protective goggles and clothes. Battery acid can cause permanent damage to eyes, burn skin, and eat holes in clothing.

Battery gases. Explosion can cause severe injury or death. Battery gases can cause an explosion. Do not smoke or permit flame or spark to occur near a battery at any time, particularly when it is charging. Avoid touching terminals with tools, etc., to prevent burns and sparks that could cause an explosion. Remove wristwatch, rings, and any other jewelry before handling battery. Never connect negative (-) battery cable to positive (+) connection terminal of starter solenoid. Do not test battery condition by shorting terminals together. Sparks could ignite battery gases or fuel vapors. Ventilate any compartment containing batteries to prevent accumulation of explosive gases. To avoid sparks, do not disturb battery charger connections while battery is being charged. Always turn battery charger off before disconnecting battery connections. Remove negative lead first and reconnect it last when disconnecting battery.

NOTE

A ground connection is required between the generator and the vehicle frame even if the battery used to start the generator is not the same as the vehicle.

AC Load Lead Connections

Each set has four color-coded load leads. The black leads (L1 and L2) are hot, the white lead (L0) is neutral and the green lead is the hazard ground. Route the load leads directly from the junction box to the vehicle AC circuit or transfer-switch connection. All installations require that the load leads be routed through flexible conduit from the generator end bracket to the junction box location. The load lead junction box must be accessible for servicing and inspection.

NOTE

Keep load lead circuit away from the generator, specifically fuel and exhaust system components.

NOTE

All field-supplied wiring must be capable of withstanding temperatures of 167°F (75°C).

AC load lead L0 (white or gray) is always the neutral lead on Kohler generator sets. Make sure the neutral of the

AC circuit in the vehicle is connected to the lead L0 (white or gray). If equipment ground-type plugs and receptacles (3-pronged) are used in the vehicle, the green wire must be connected to the U-shaped pin. On vehicles which also have provisions for using an outside AC power source, the neutral as well as the hot (or black) leads must be completely isolated from the generator set when power is switched to the outside source. See Figure 6-17.

NOTE

Use a triple-pole, double-throw transfer switch rated for the calculated load of the RV to transfer the load from one source to the other. Install a ground-fault circuit interrupter in the wiring system to protect all branch circuits.

NOTE

The AC load circuit of the generator set must be protected by a circuit breaker(s) against overload or short circuit.

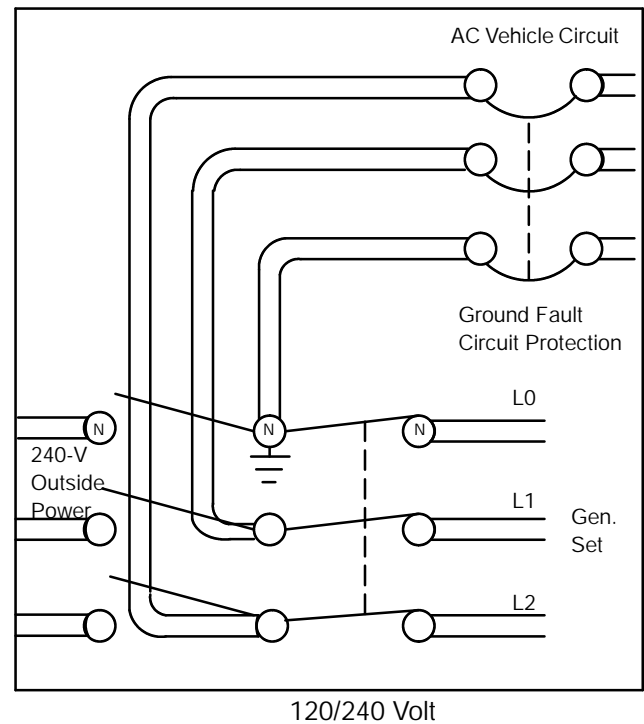
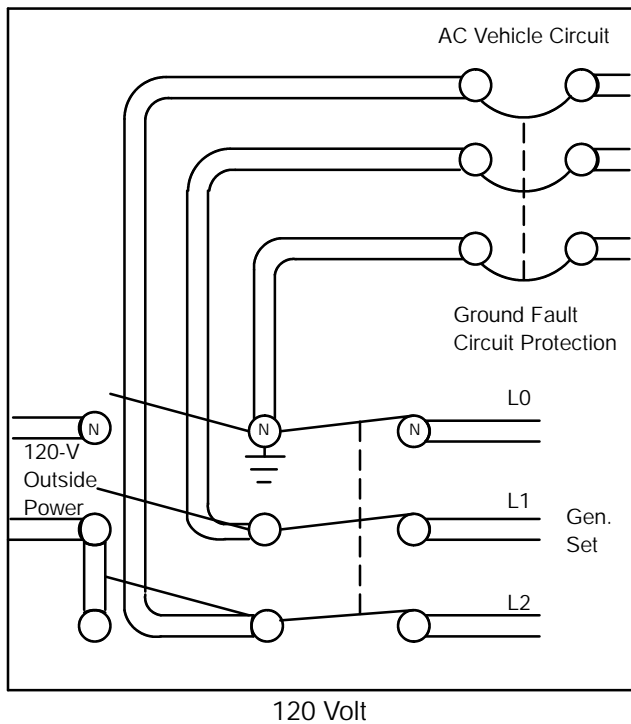



Figure 6-17. Transfer Switch Connections, 3-Wire AC Circuit

⚠ WARNING

<p>Hazardous voltage. Backfeed to utility system can cause severe injury, death, or property damage.</p> <p>Do not connect to any building electrical system without connecting through an approved device and after building main switch is open.</p>

Electrical backfeed to utility. Hazardous backfeed voltage can cause severe injury or death. Connect generator set to building/campground electrical system only through an approved device and after building/campground main switch is open. Backfeed connections can cause serious injury or death to utility personnel working on power lines and/or personnel in the vicinity of the work area. Unauthorized connection to utility electrical system may be unlawful in some states and/or localities. Install a transfer switch to prevent interconnection of generator set power and other sources of power.

NOTE

For standby service connect output of generator to suitably rated transfer switch in accordance with Canadian Electrical Code, Part 1.

Remote Switch Connection (Single-Phase Models Only)

Controllers include an accessory plug (P3) for easy connection of the remote switch to the preheat switch, oil pressure gauge (if equipped), water temperature gauge (if equipped) and generator ON lamp wiring harness (available separately). One end of the 15 in. (38.1 cm) P3 wiring harness plugs directly into the controller. The pigtail leads on the remaining end of the harness connect to the appropriate remote panel terminals via customer-supplied wiring. Be sure to connect the remote operating controls to the correct P3 wire harness lead. See Figure 6-18 and Figure 6-19 for identification of P3 harness leads.

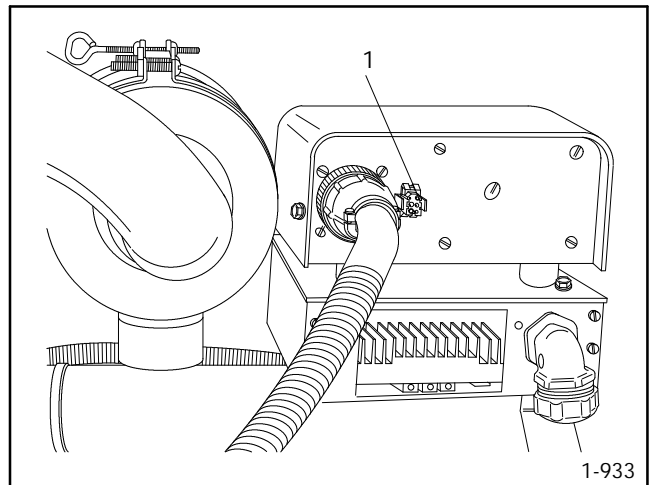

1. Remote connection

Figure 6-18. Controller Remote Connection

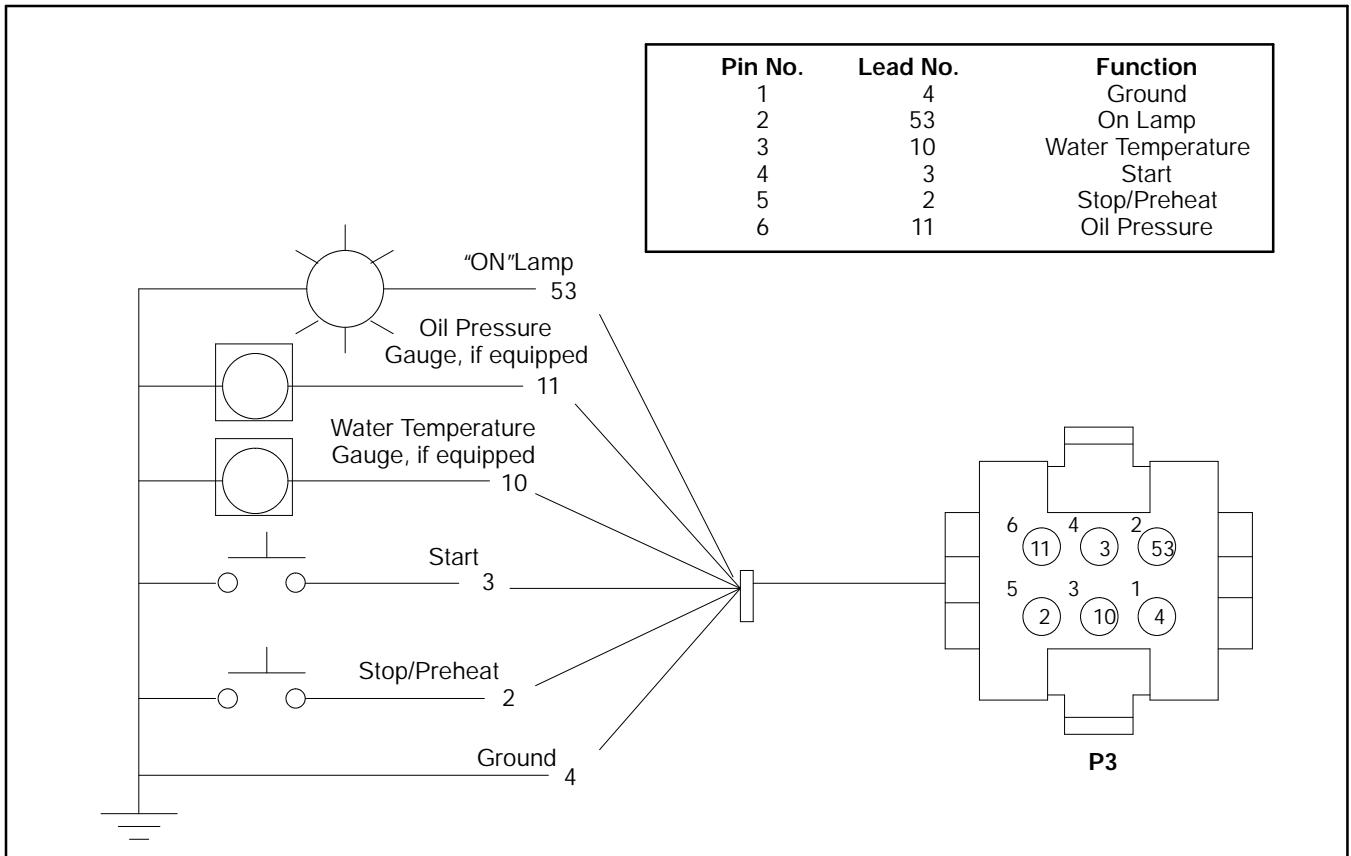
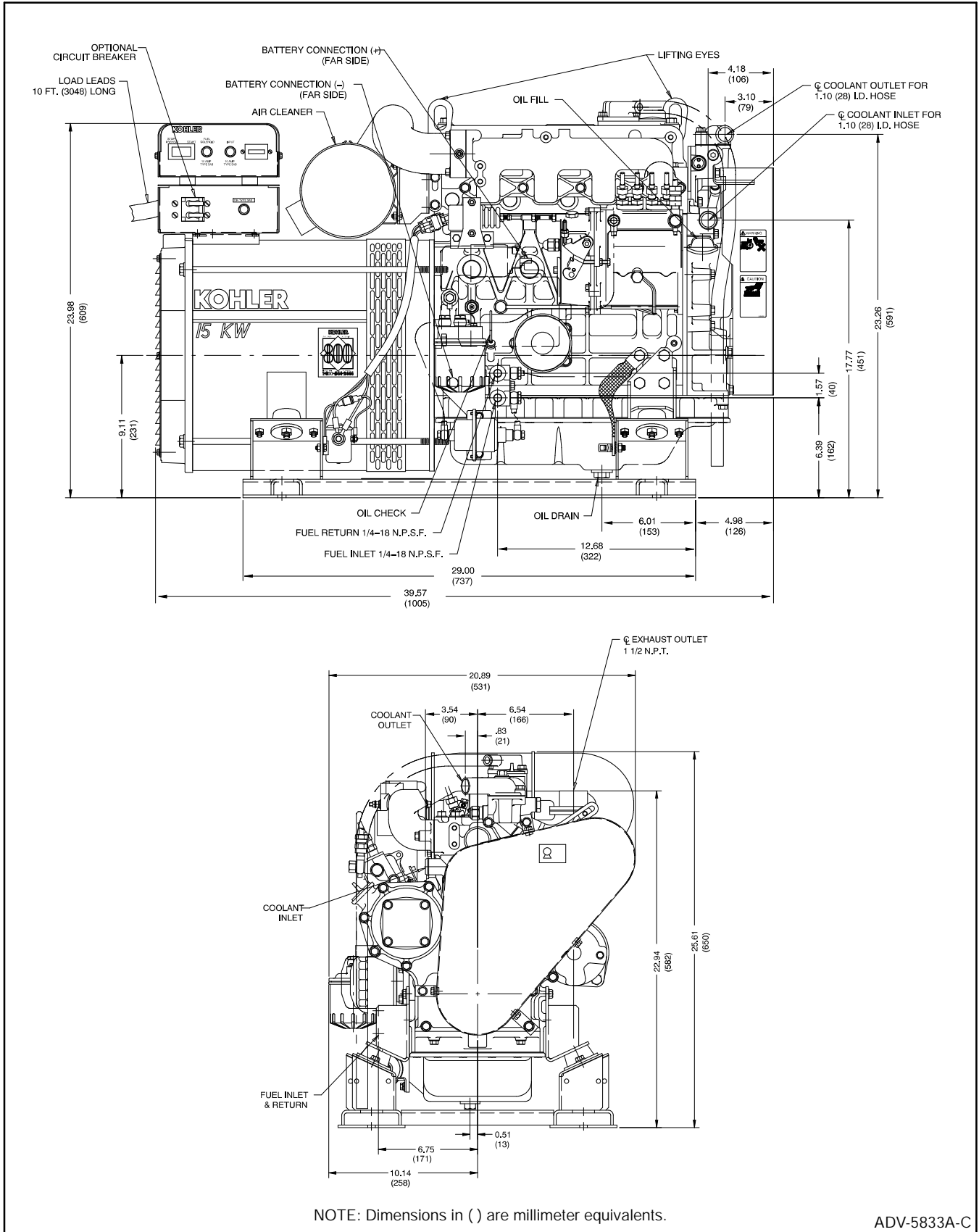

Figure 6-19. Panel Wiring (P3 Wiring Harness)

Notes

Section 7. Installation Drawings



ADV-5833A-C

15CCO RV Remote Radiator Single-Phase Model

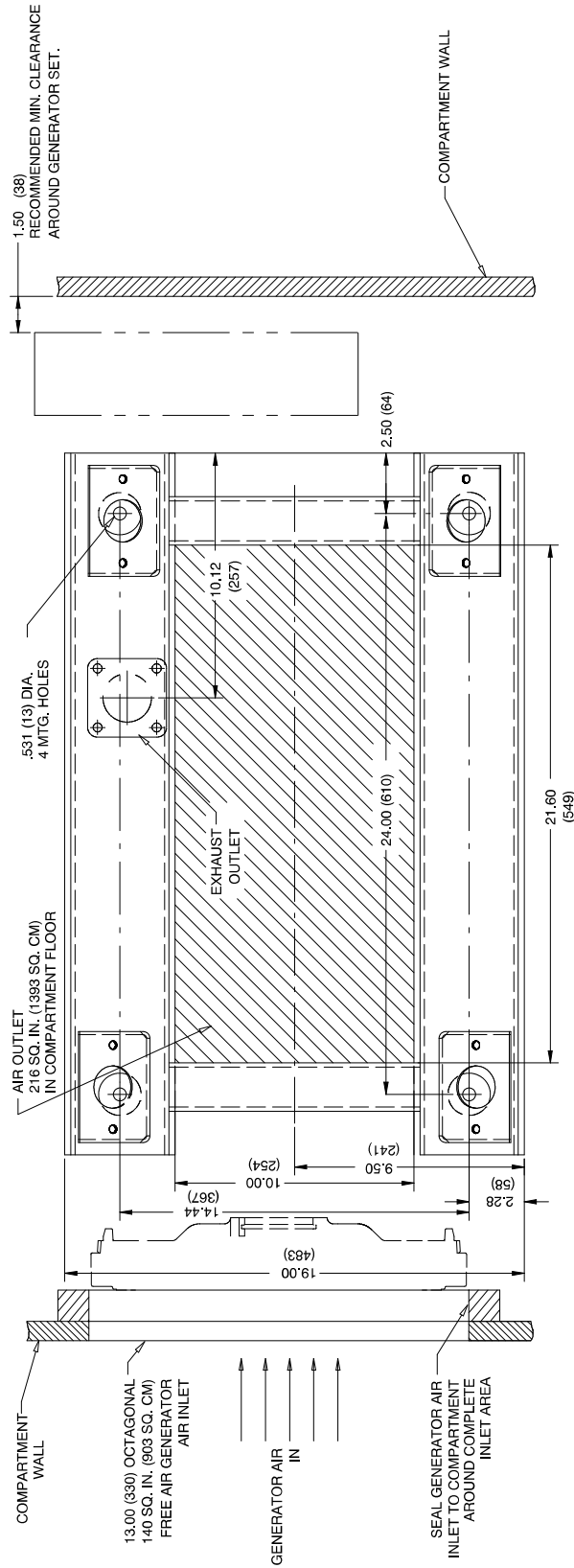

NOTE: Dimensions in () are millimeter equivalents.

ADV-5833A-C

15CCO RV Remote Radiator Single-Phase Mounting Pattern

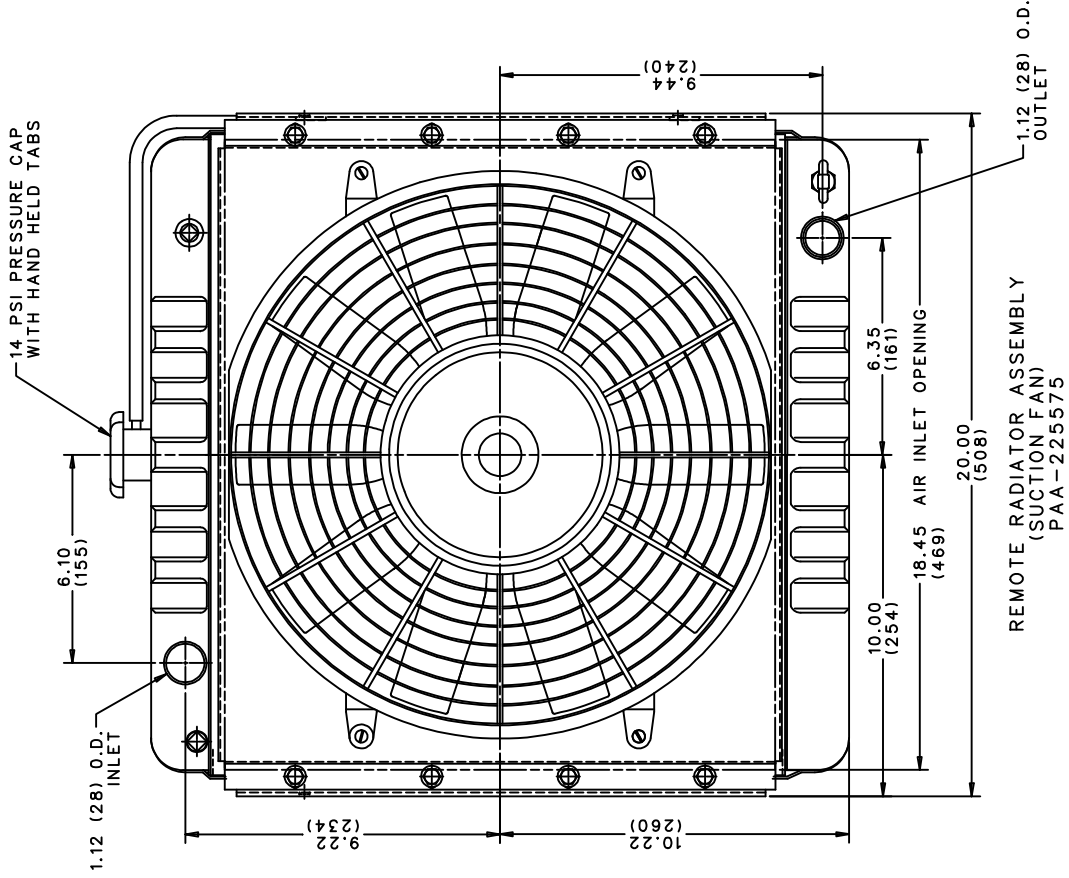
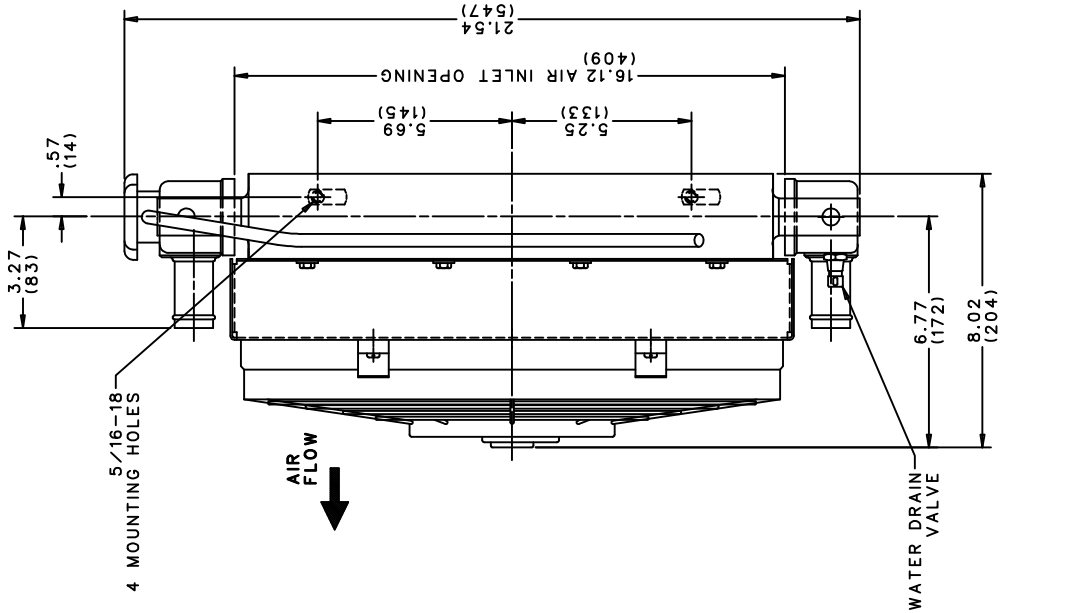

NOTE: Dimensions in () are millimeter equivalents.

ADV-5833B-A

15CCO RV Remote Radiator (Suction)

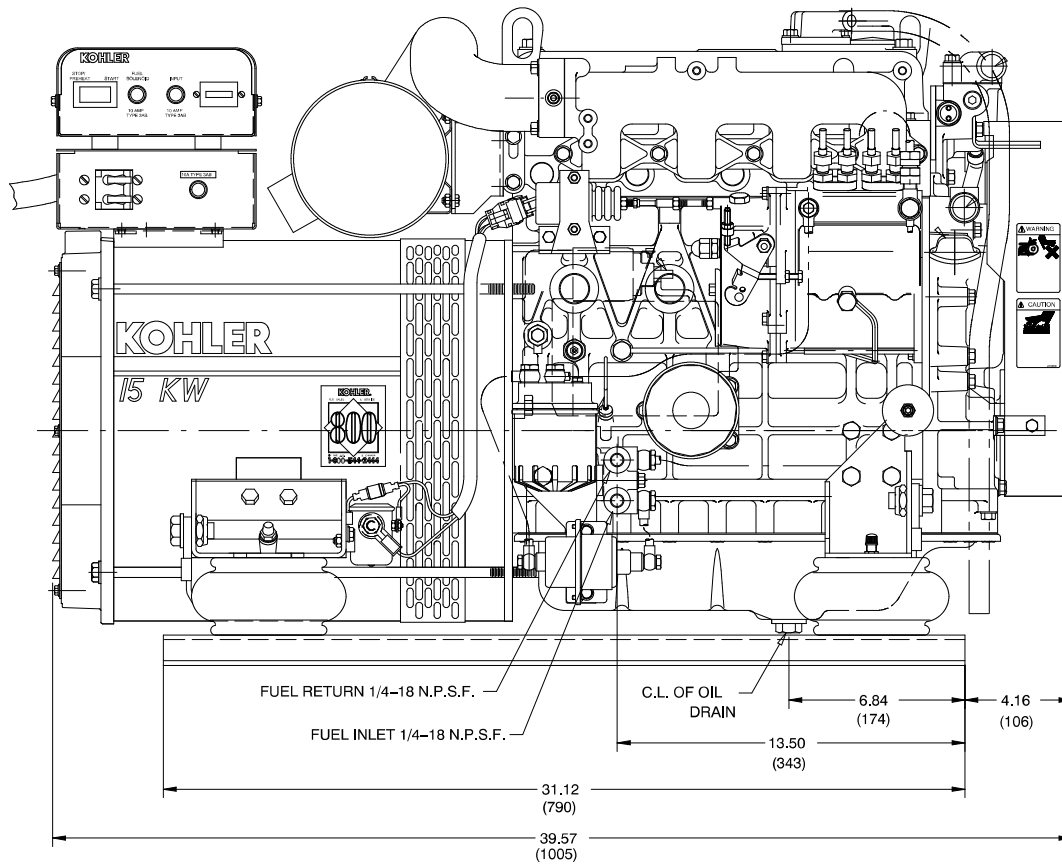

NOTE: Dimensions in () are millimeter equivalents.

ADV-5833C-A

15CCO RV Remote Radiator (with Airbag Mounts) Single-Phase Model

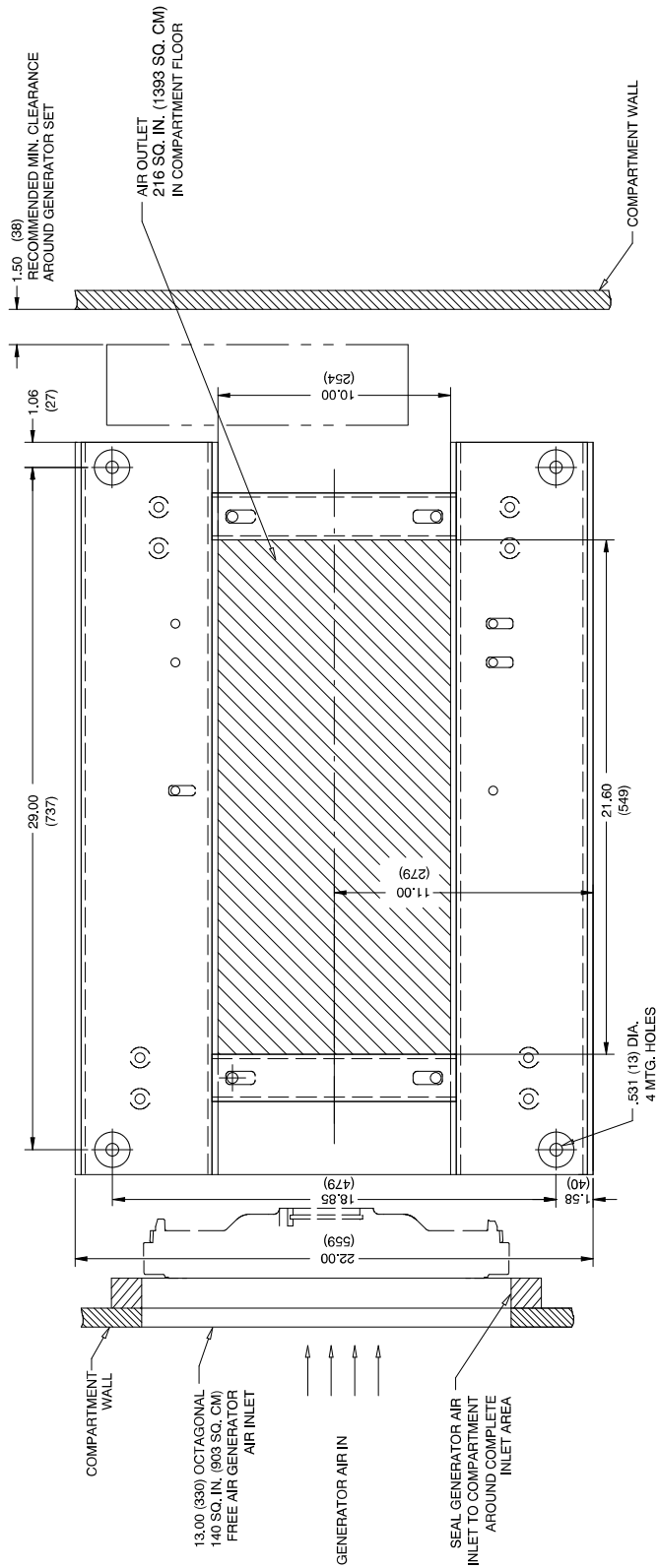

NOTE: Dimensions in () are millimeter equivalents.

ADV-5833C-A

15CCO RV Remote Radiator (with Airbag Mounts) Single-Phase Mounting Pattern

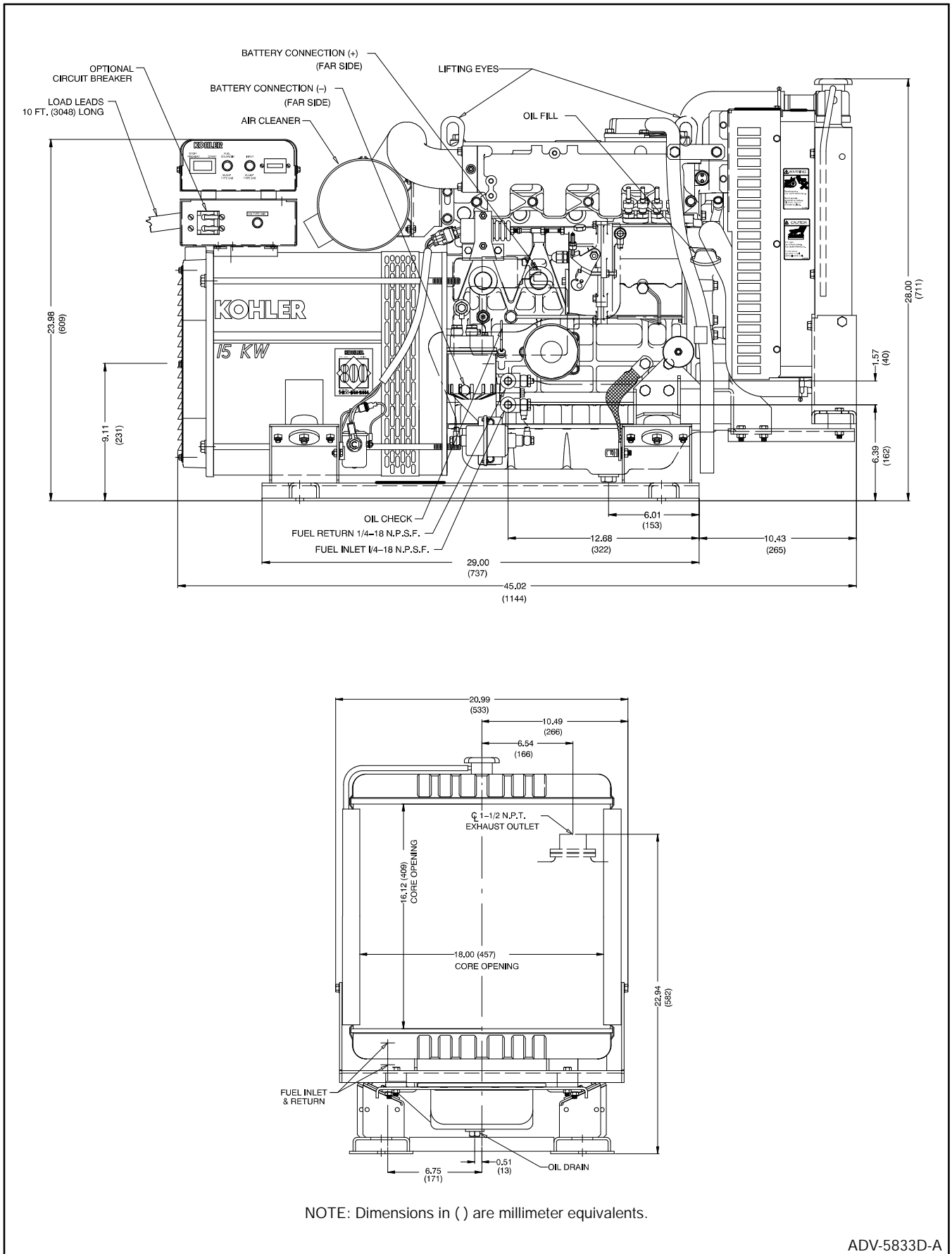

ADV-5833D-A

15CCO RV Inline (Suction) Radiator Single-Phase Model

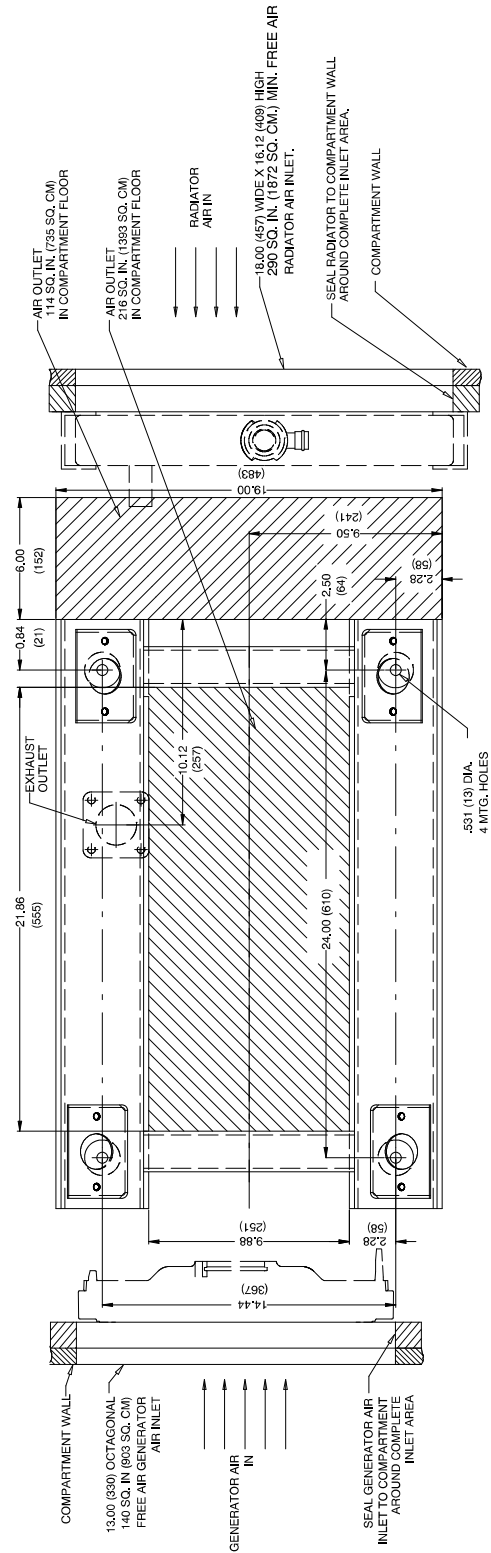

NOTE: Dimensions in () are millimeter equivalents.

ADV-5833D-A

15CCO RV In-line Radiator Single-Phase Mounting Pattern

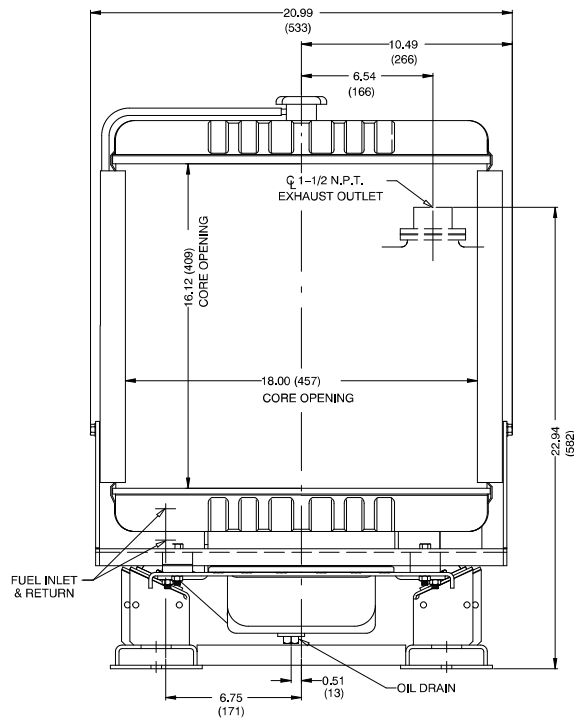
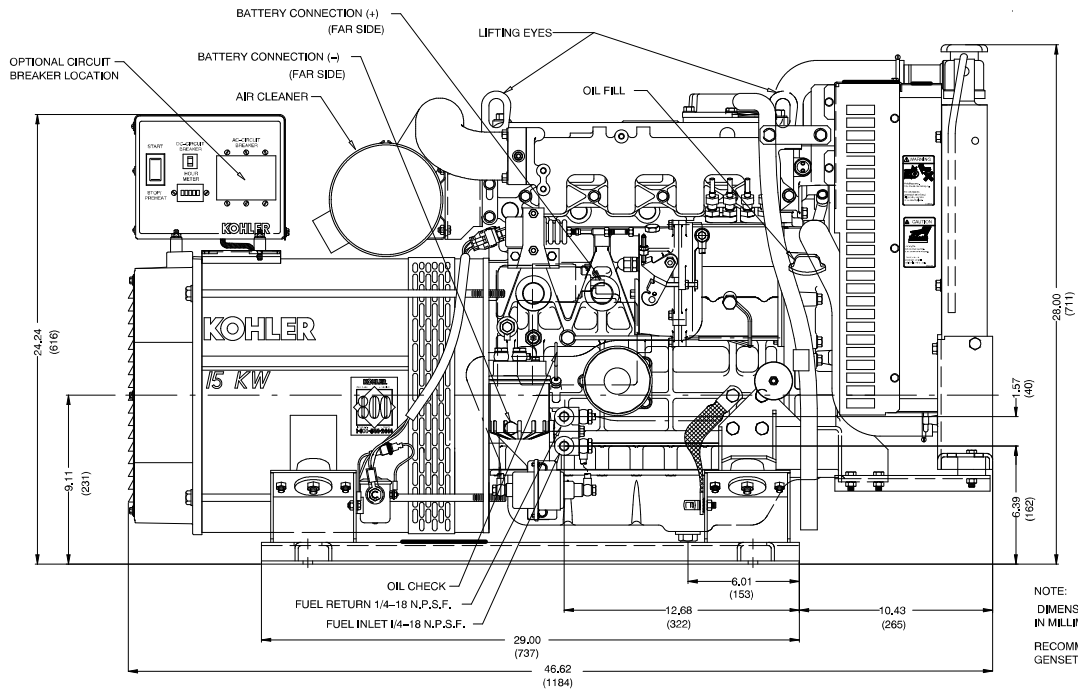

NOTE: Dimensions in () are millimeter equivalents.

ADV-5879-B

15CCO MOBILE In-line (Suction) Radiator Three-Phase Model

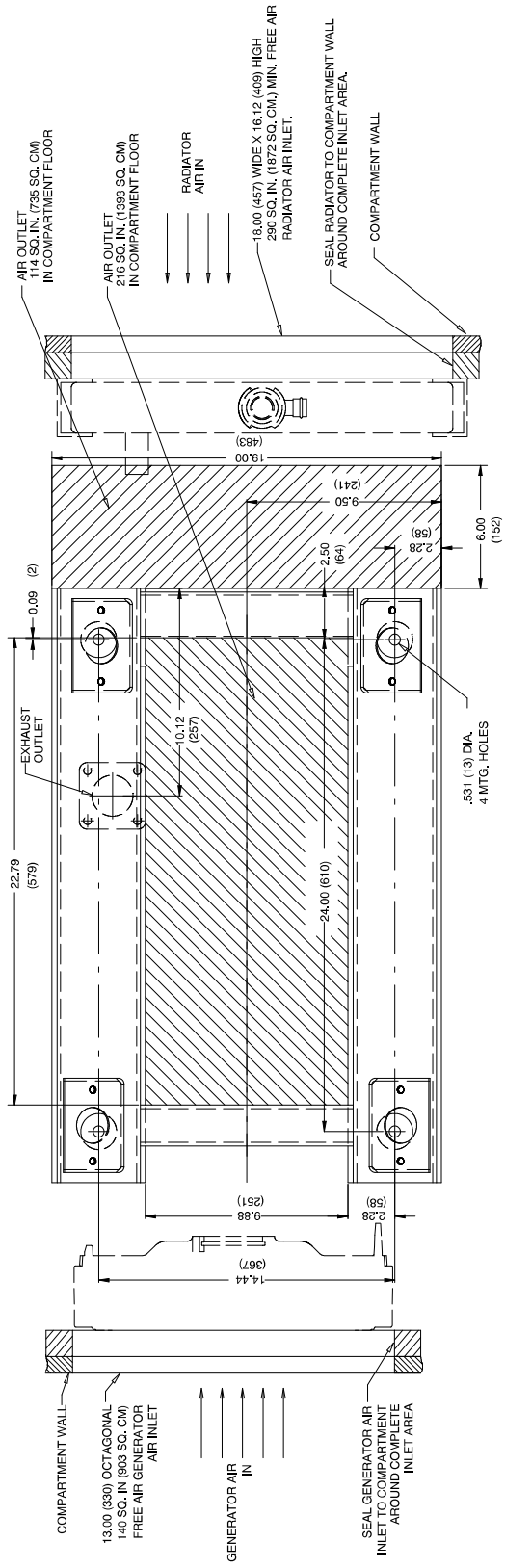

NOTE: Dimensions in () are millimeter equivalents.

ADV-5879-B

15CCOZ MOBILE In-line Radiator Three-Phase Model

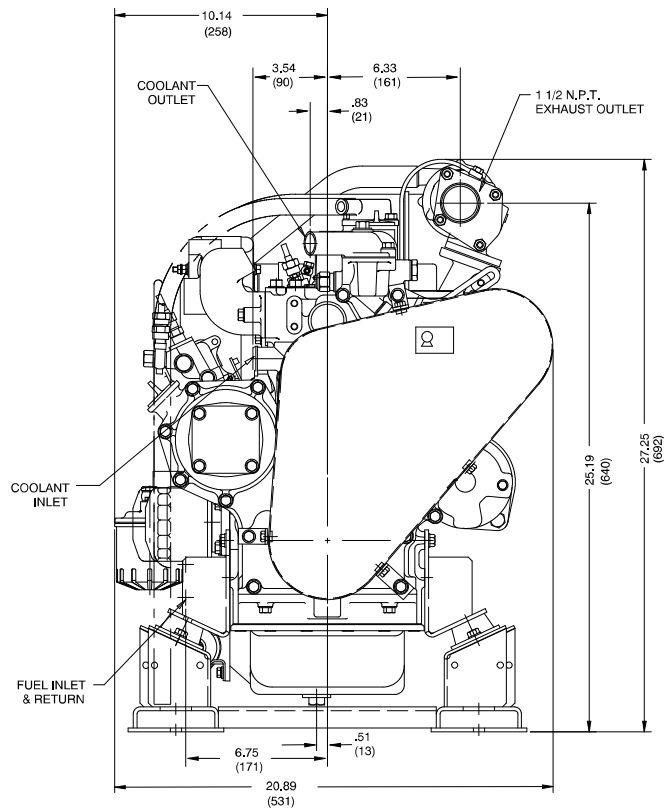
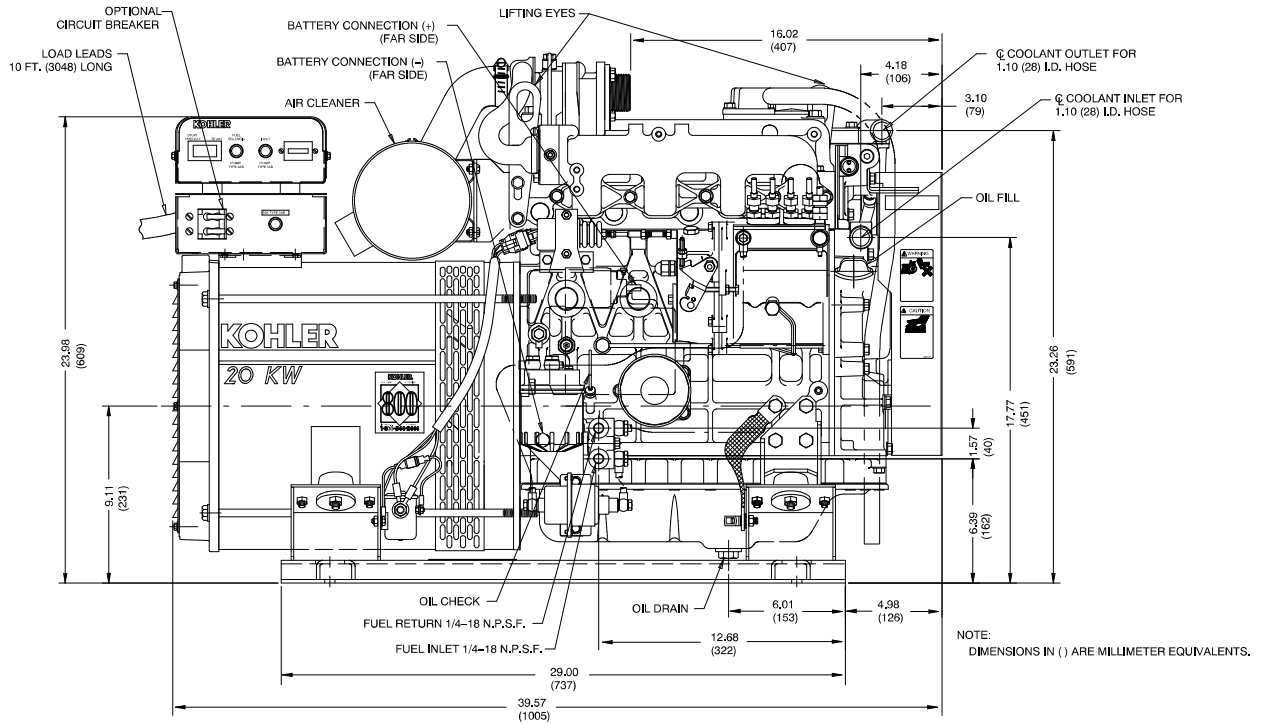

NOTE: Dimensions in () are millimeter equivalents.

ADV-5834A-C

20CCO RV Remote Radiator Single-Phase Model

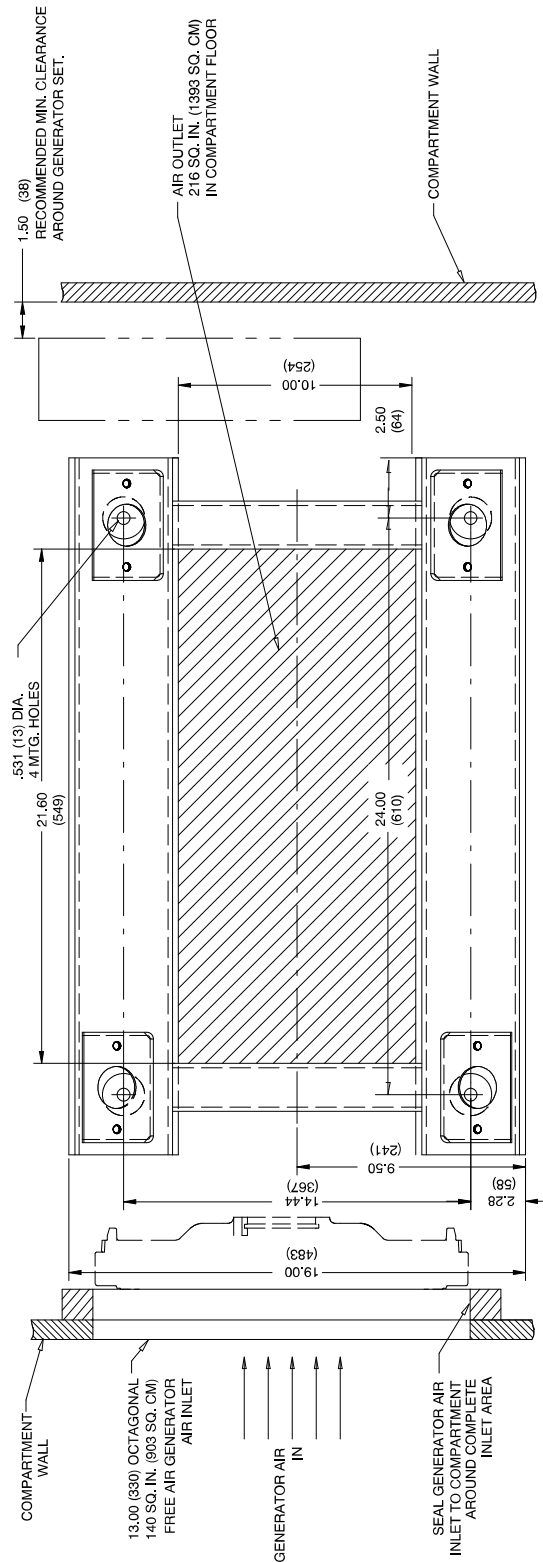

NOTE: Dimensions in () are millimeter equivalents.

ADV-5834A-C

20CCO RV Remote Radiator Single-Phase Mounting Pattern

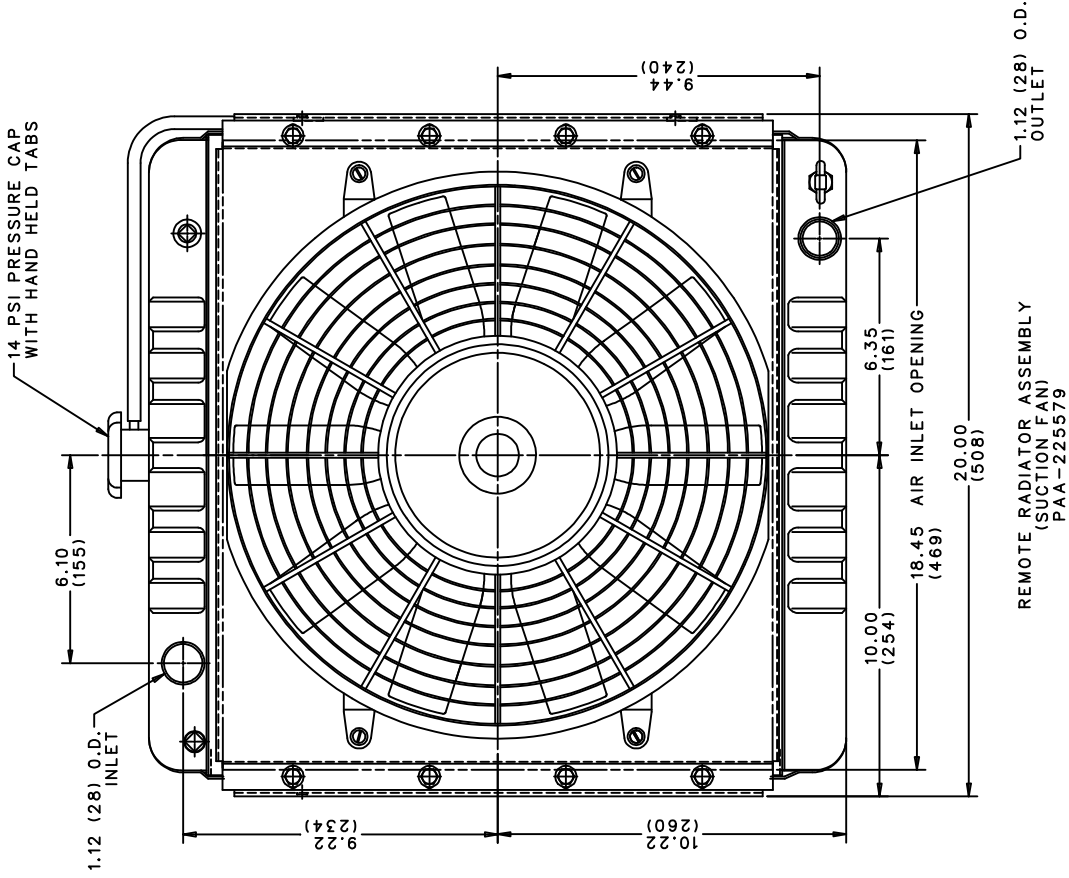
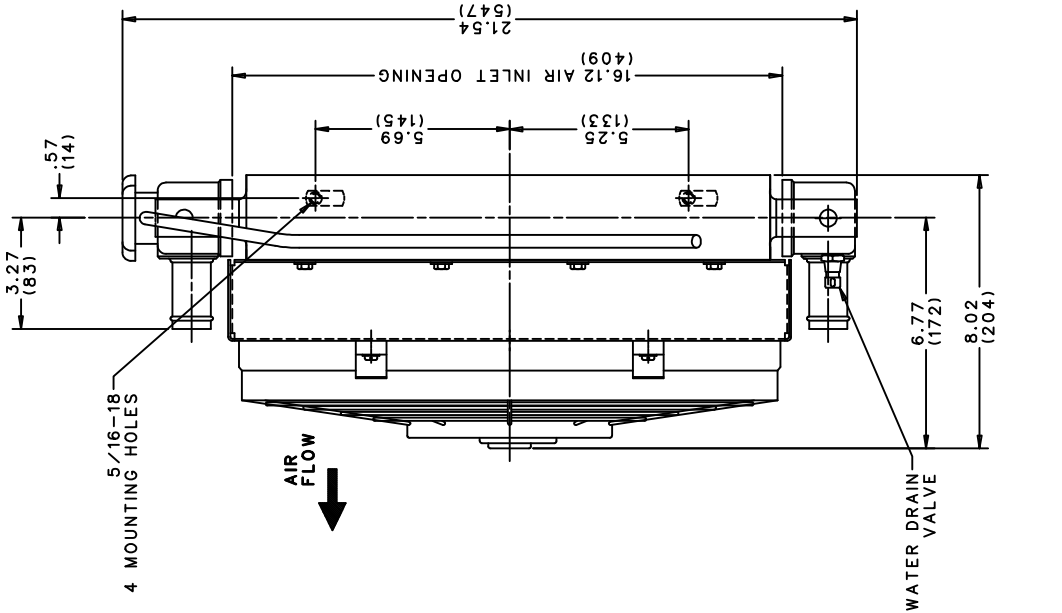

NOTE: Dimensions in () are millimeter equivalents.

REMOTE RADIATOR ASSEMBLY
(SUCTION FAN)
PAA-225579

ADV-5834B-A

20CCO RV Remote Radiator (Suction)

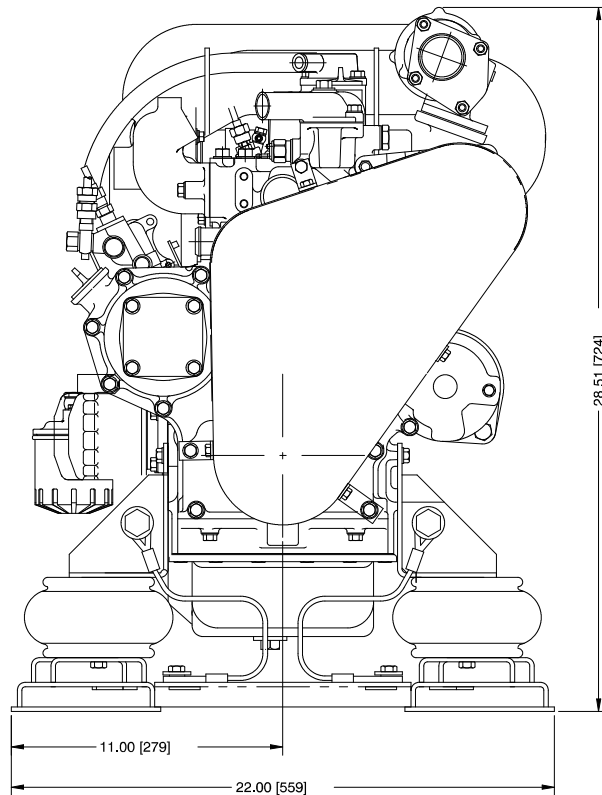
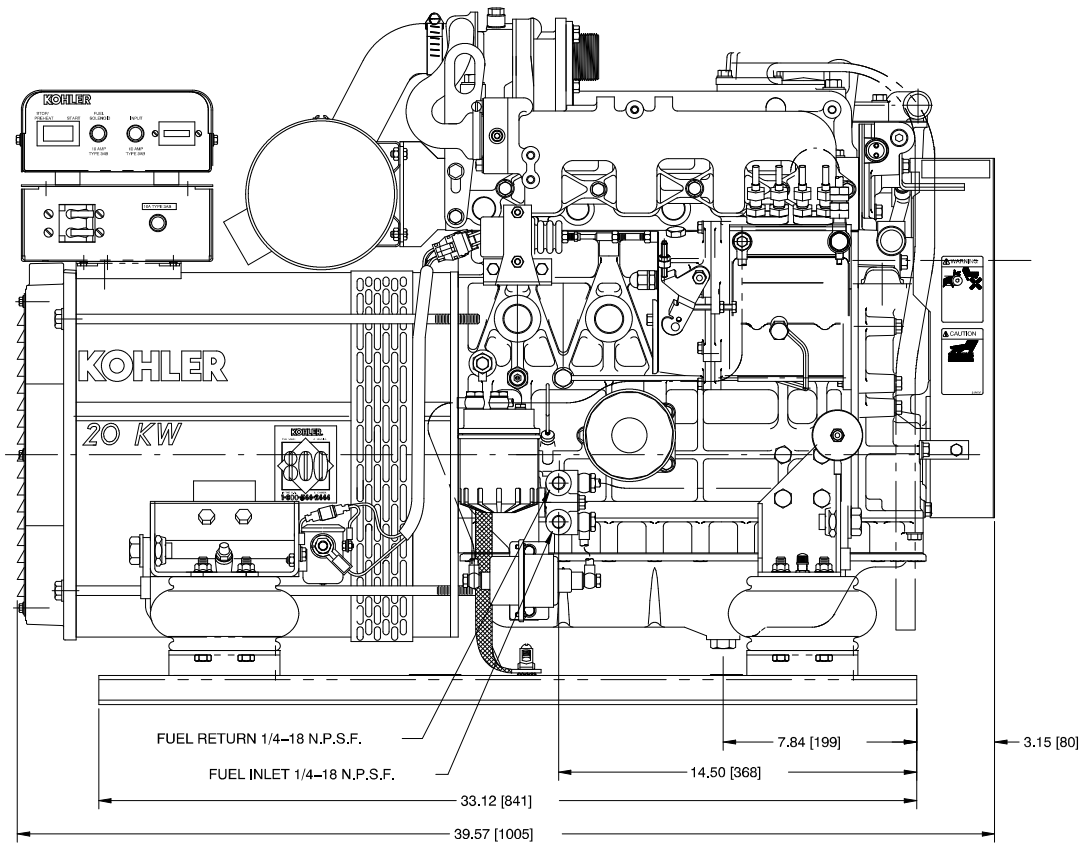

NOTE: Dimensions in () are millimeter equivalents.

ADV-5834C-B

20CCO RV Remote Radiator (with Airbag Mounts) Single-Phase Model

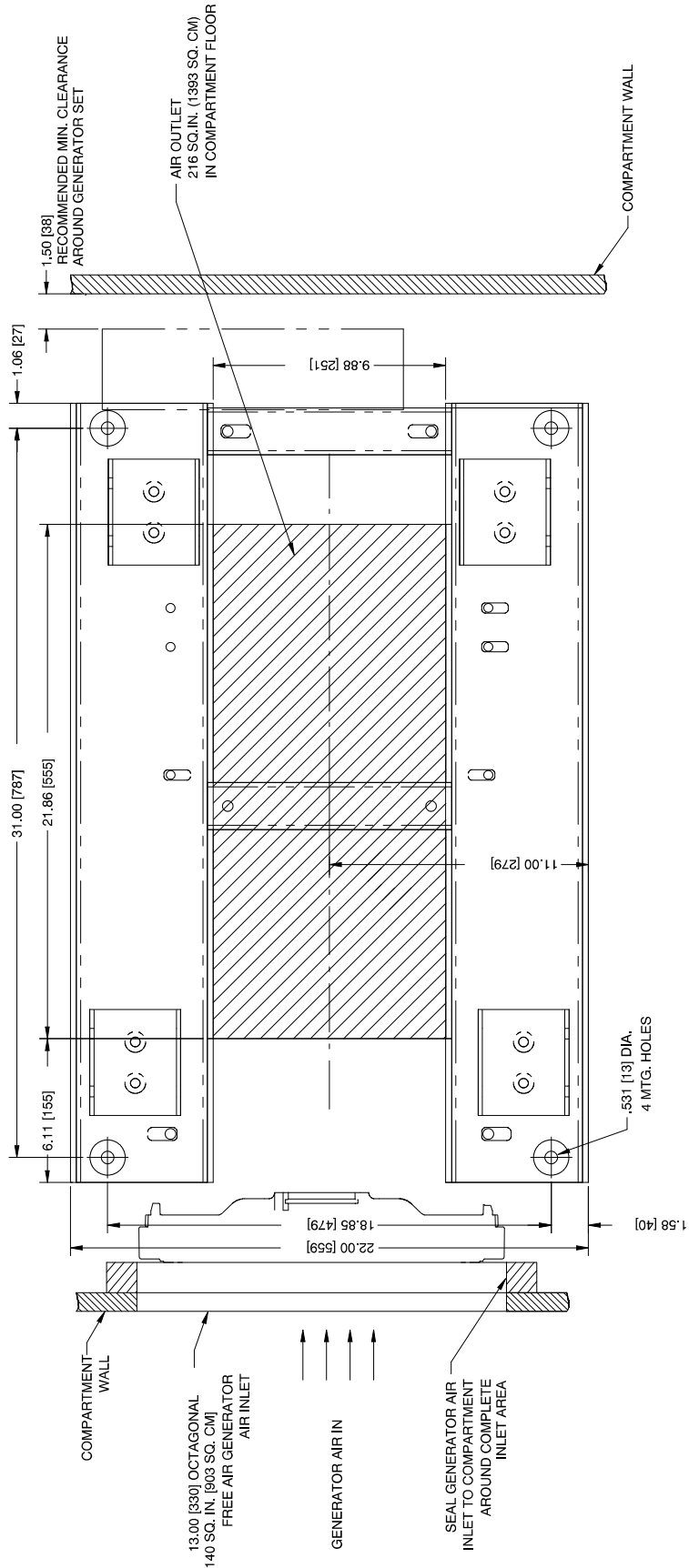

ADV-5834C-B

20CCO RV Remote Radiator (with Airbag Mounts) Single-Phase Mounting Pattern

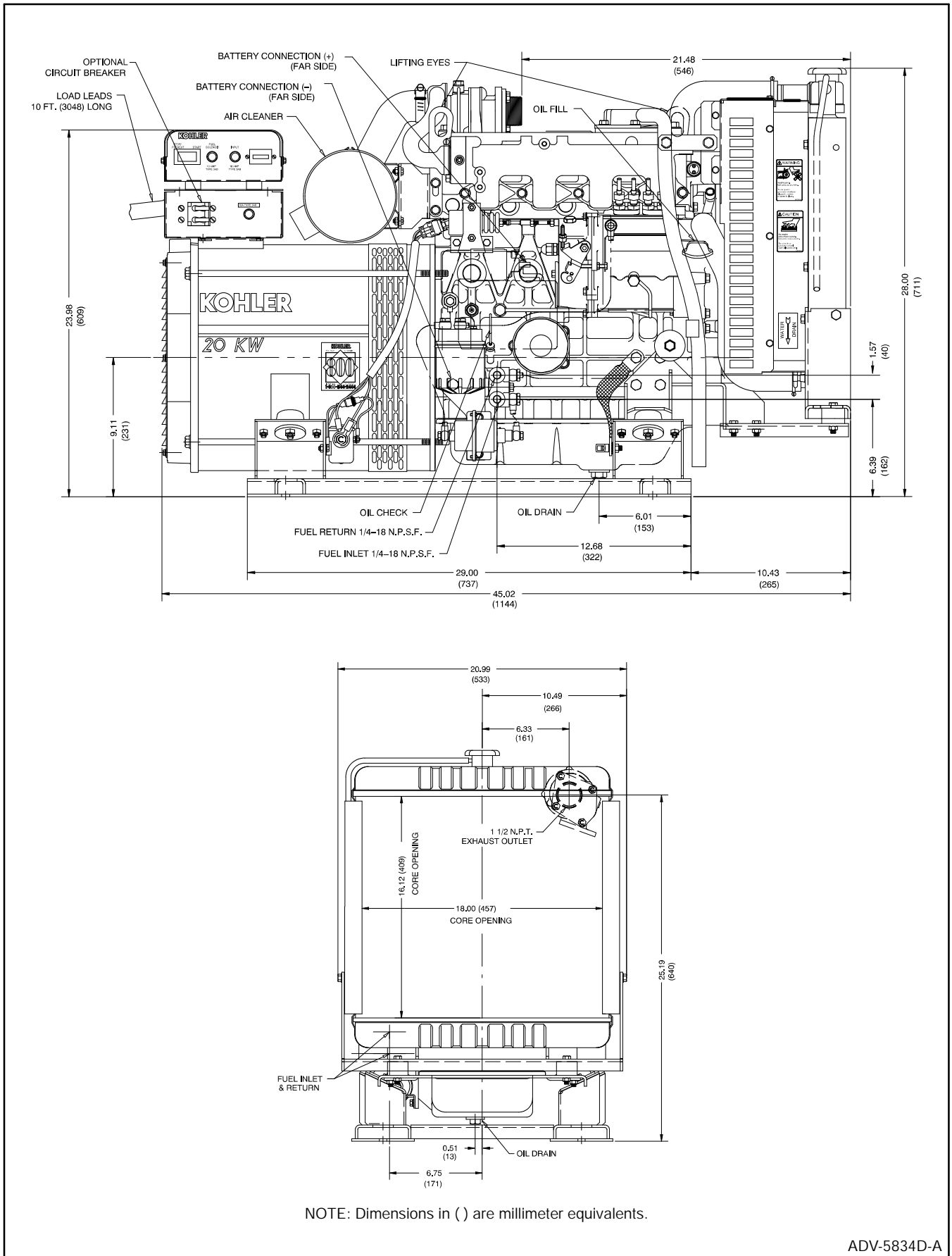

2000 RV In-line Radiator Single-Phase Model

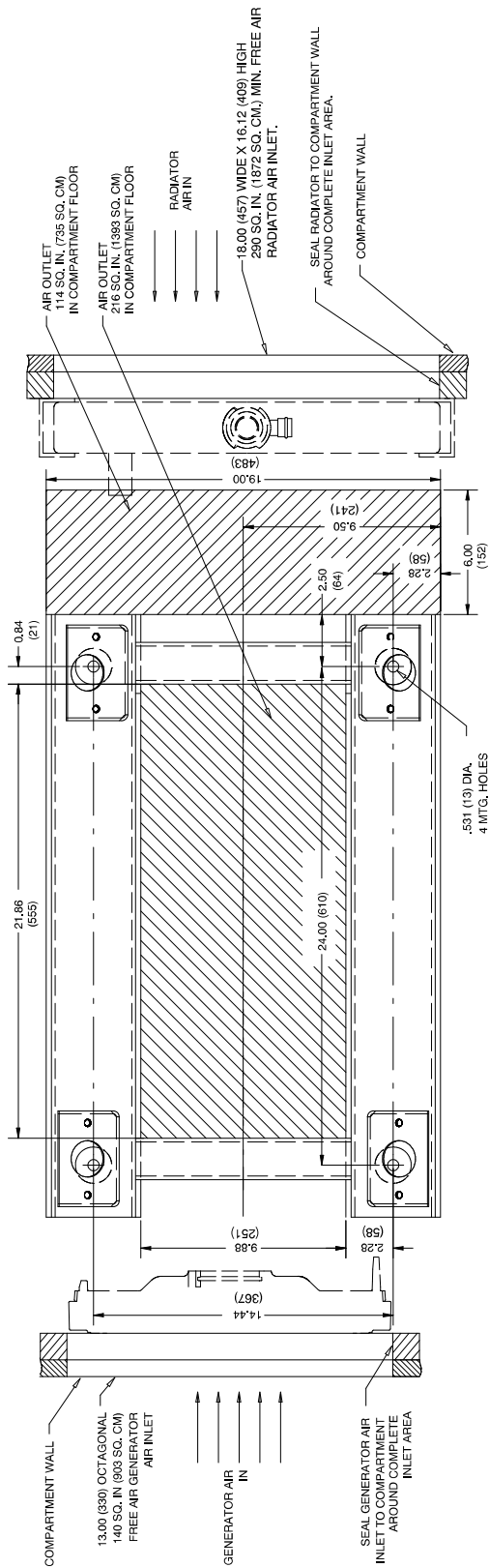

NOTE: Dimensions in () are millimeter equivalents.

ADV-5834D-A

20CCO RV In-line Radiator Single-Phase Mounting Pattern

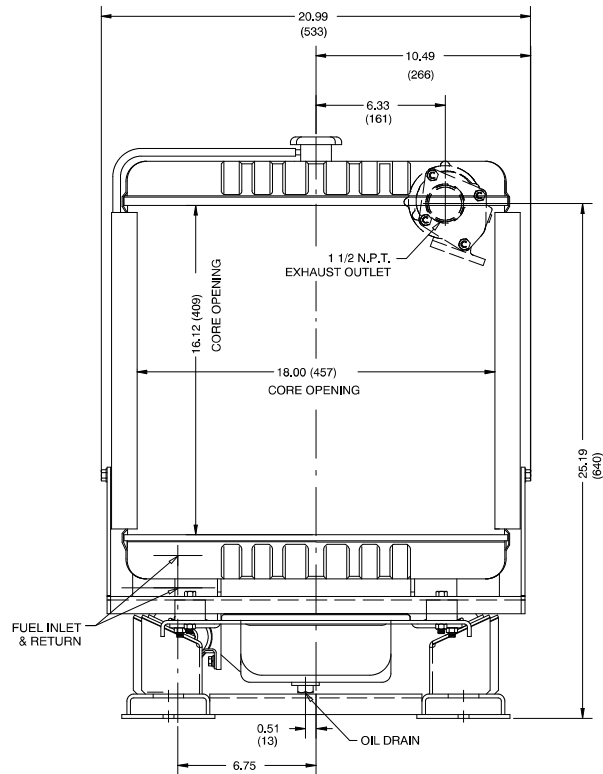
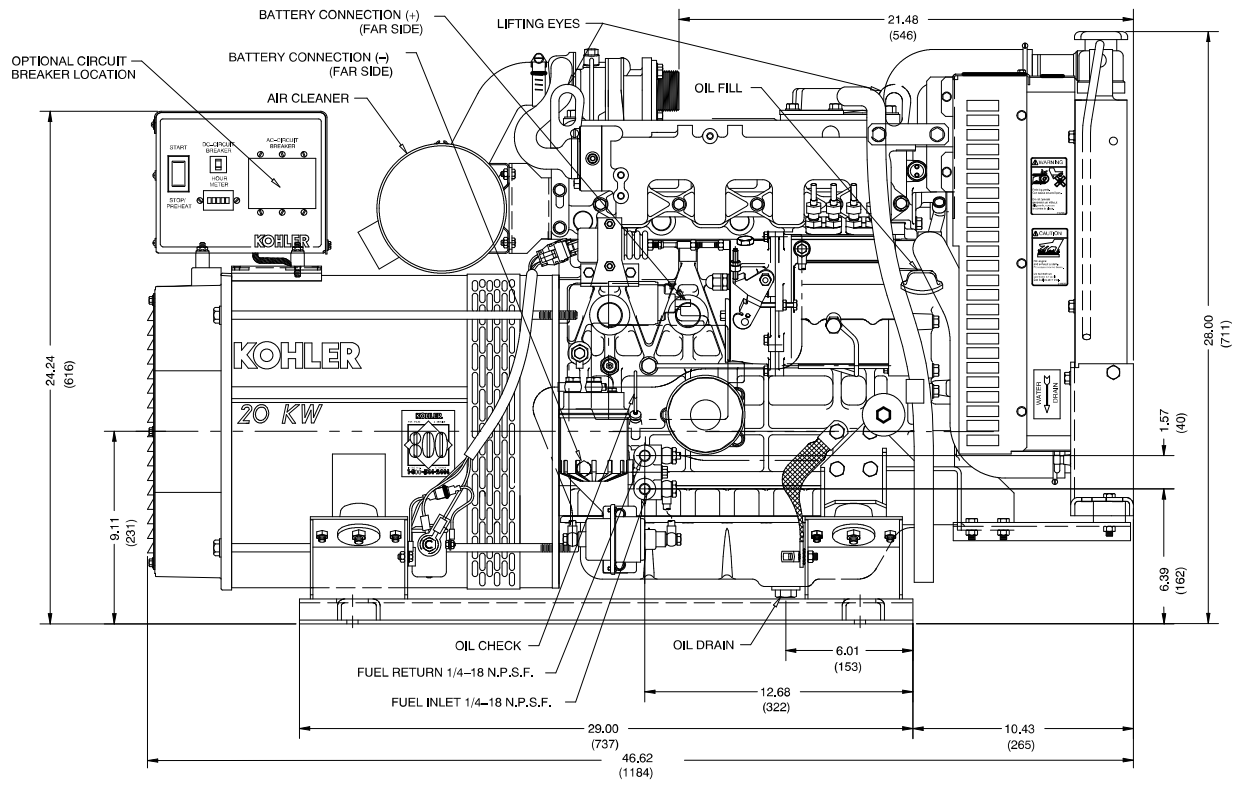

NOTE: Dimensions in () are millimeter equivalents.

ADV-5880-A

20CCOZ MOBILE In-line (Suction) Radiator Three-Phase Model

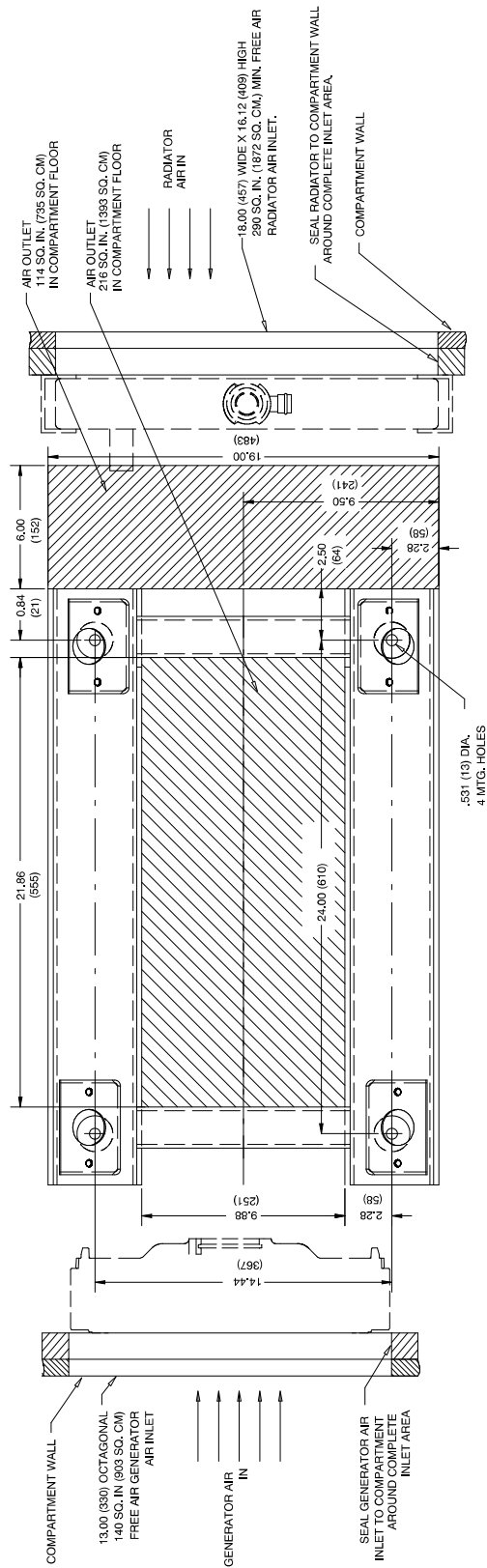

NOTE: Dimensions in () are millimeter equivalents.

ADV-5880-A

20CCOZ MOBILE In-line Radiator Three-Phase Mounting Pattern

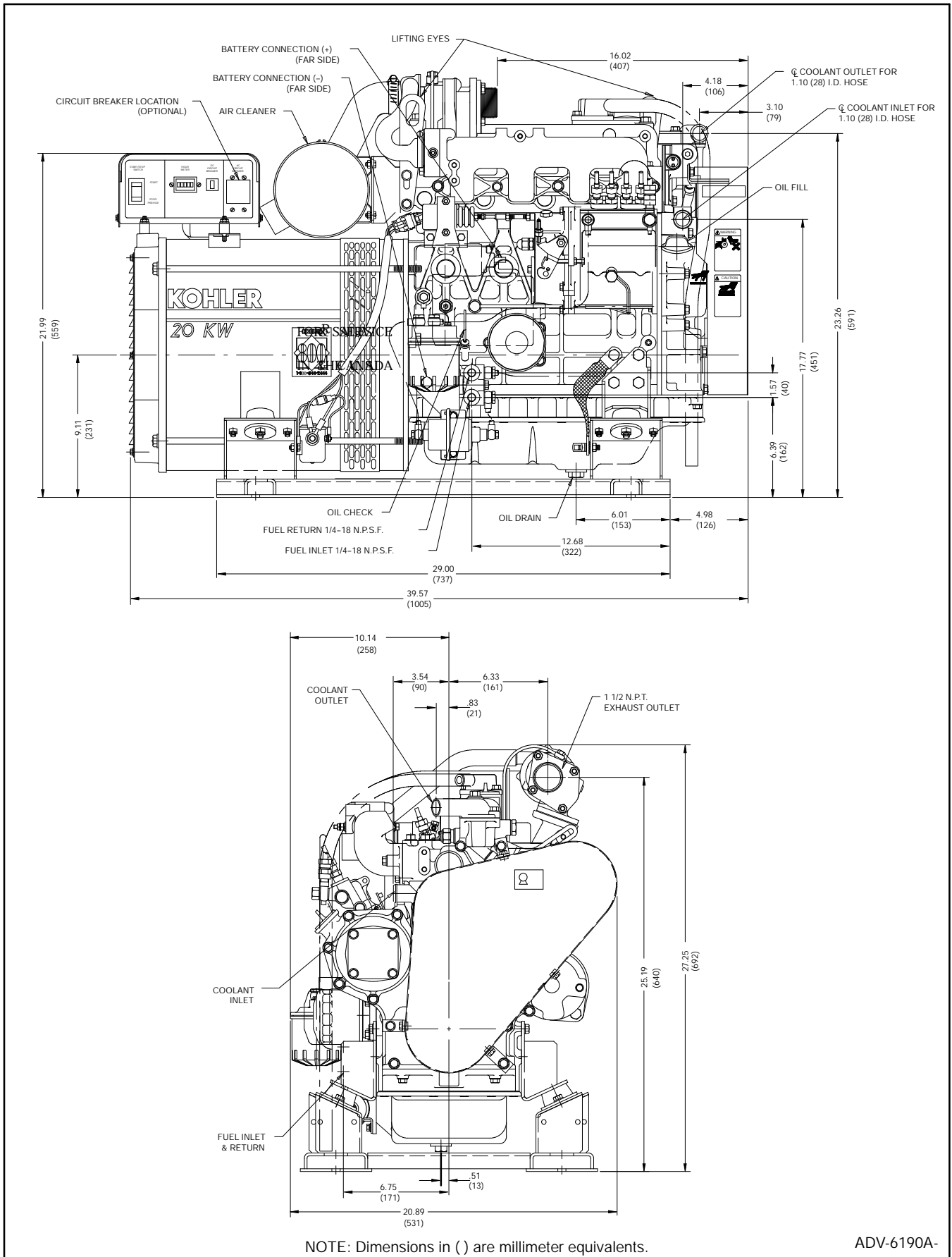

20 kW RV Remote Radiator (spec PA-132322)

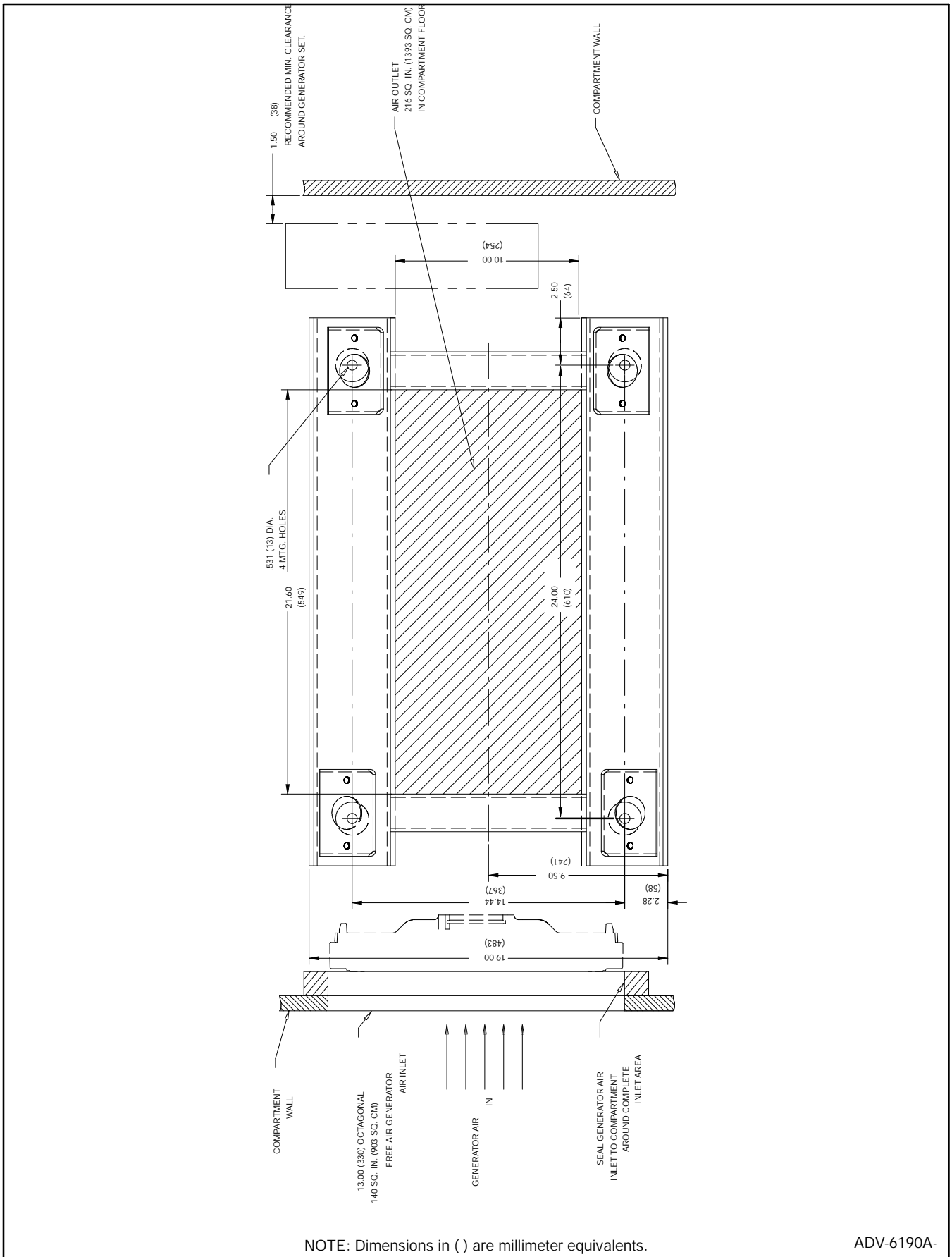

20 kW RV Remote Radiator Mounting Pattern (spec PA-135322)

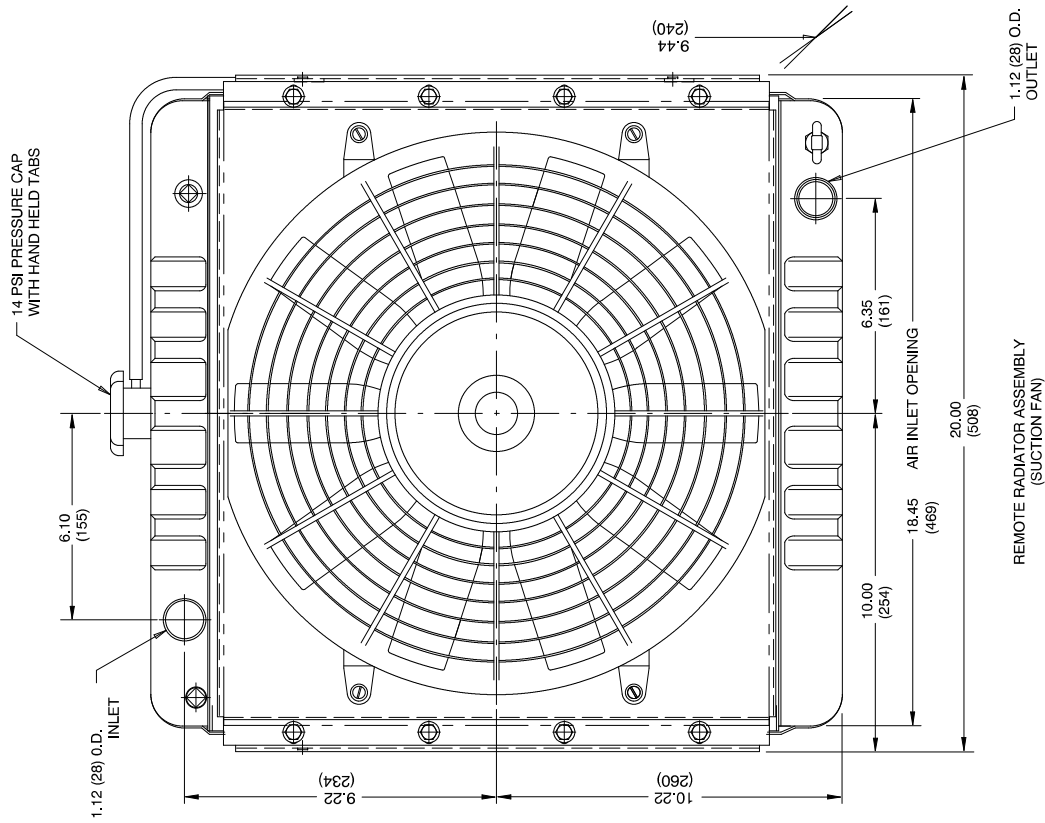
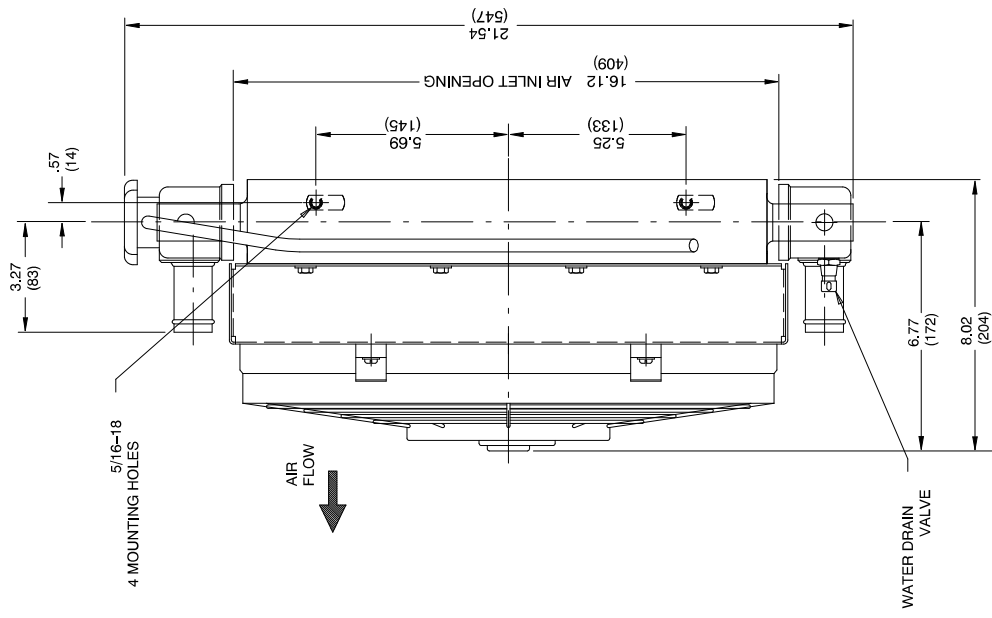

NOTE: Dimensions in () are millimeter equivalents.

ADV-6190B-

20 kW RV Remote Radiator (Suction)

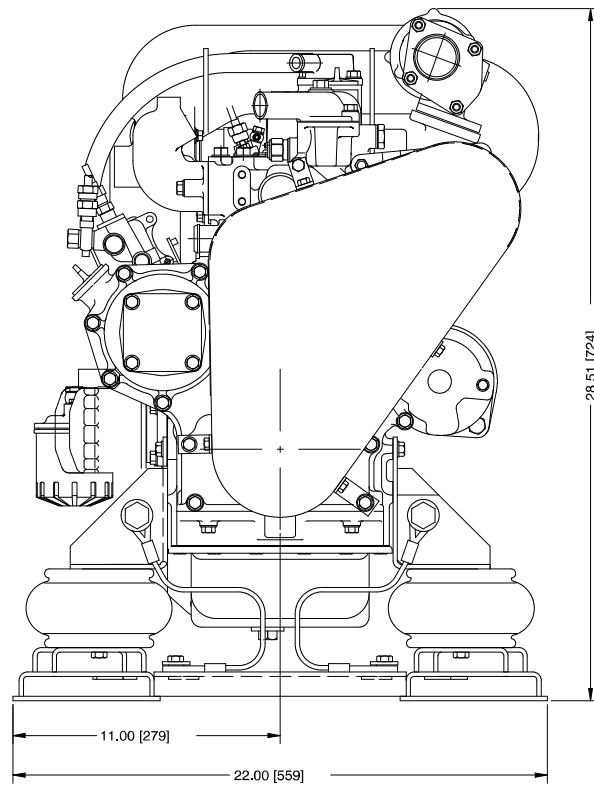
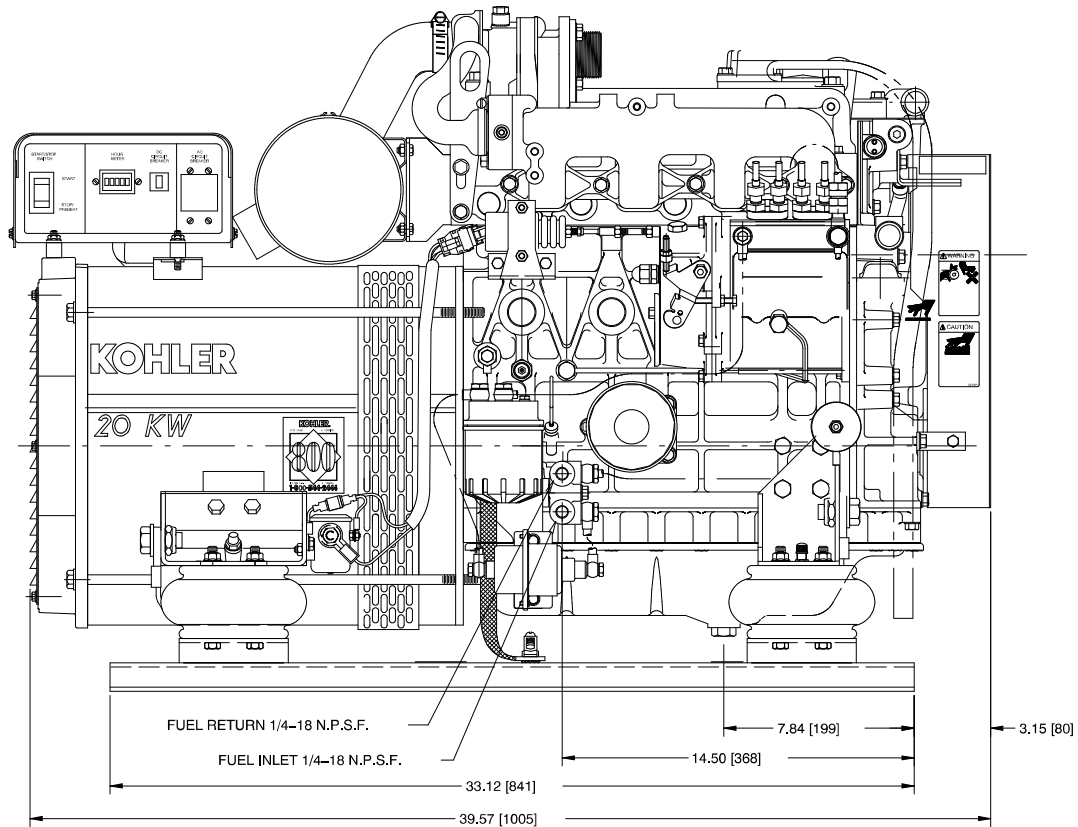

NOTE: Dimensions in () are millimeter equivalents.

ADV-6190C-

20 kW RV Remote Radiator with Airbag Mounts (spec PA-135322)

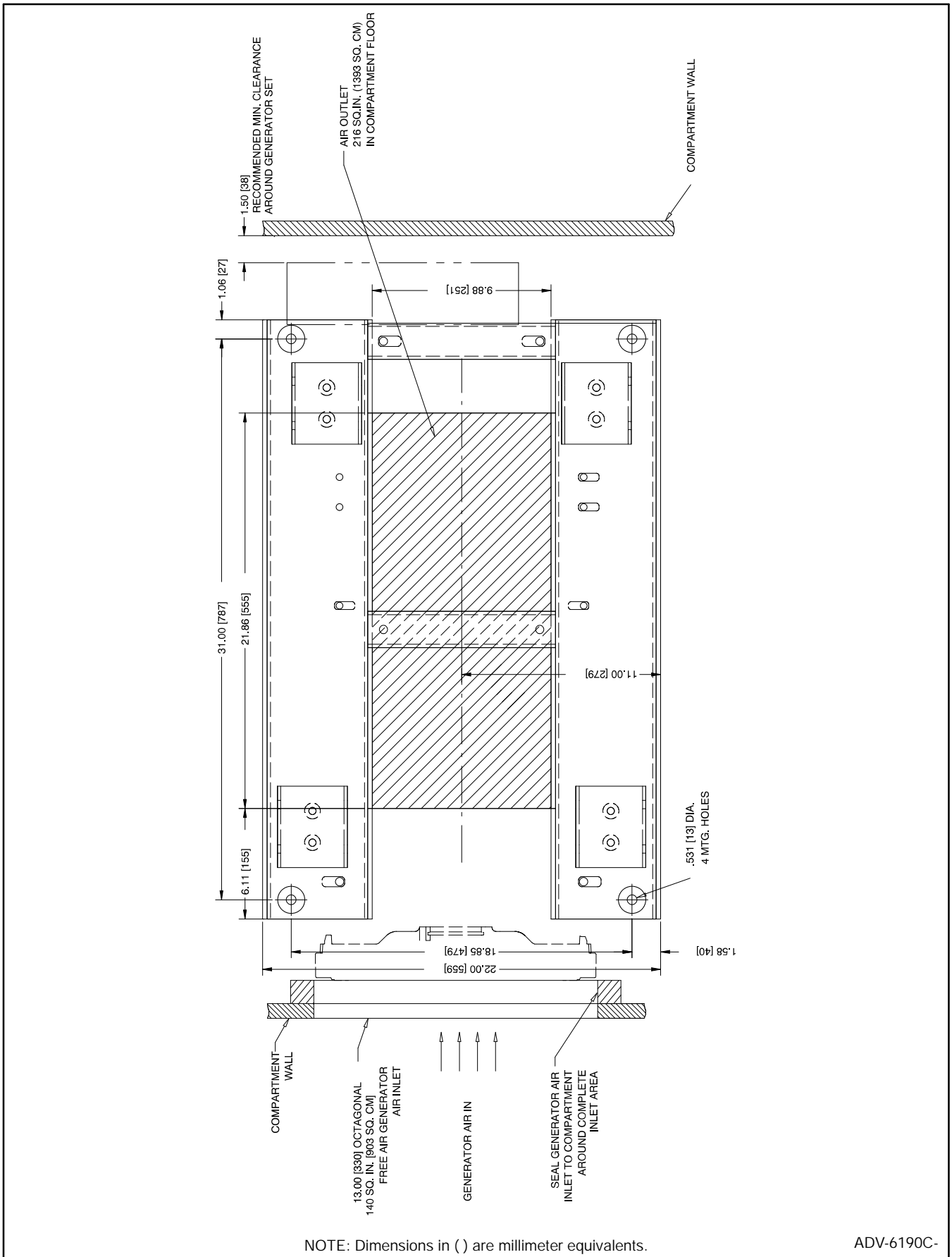

20 kW RV Remote Radiator with Air Bags Mounting Pattern (spec PA-135322)

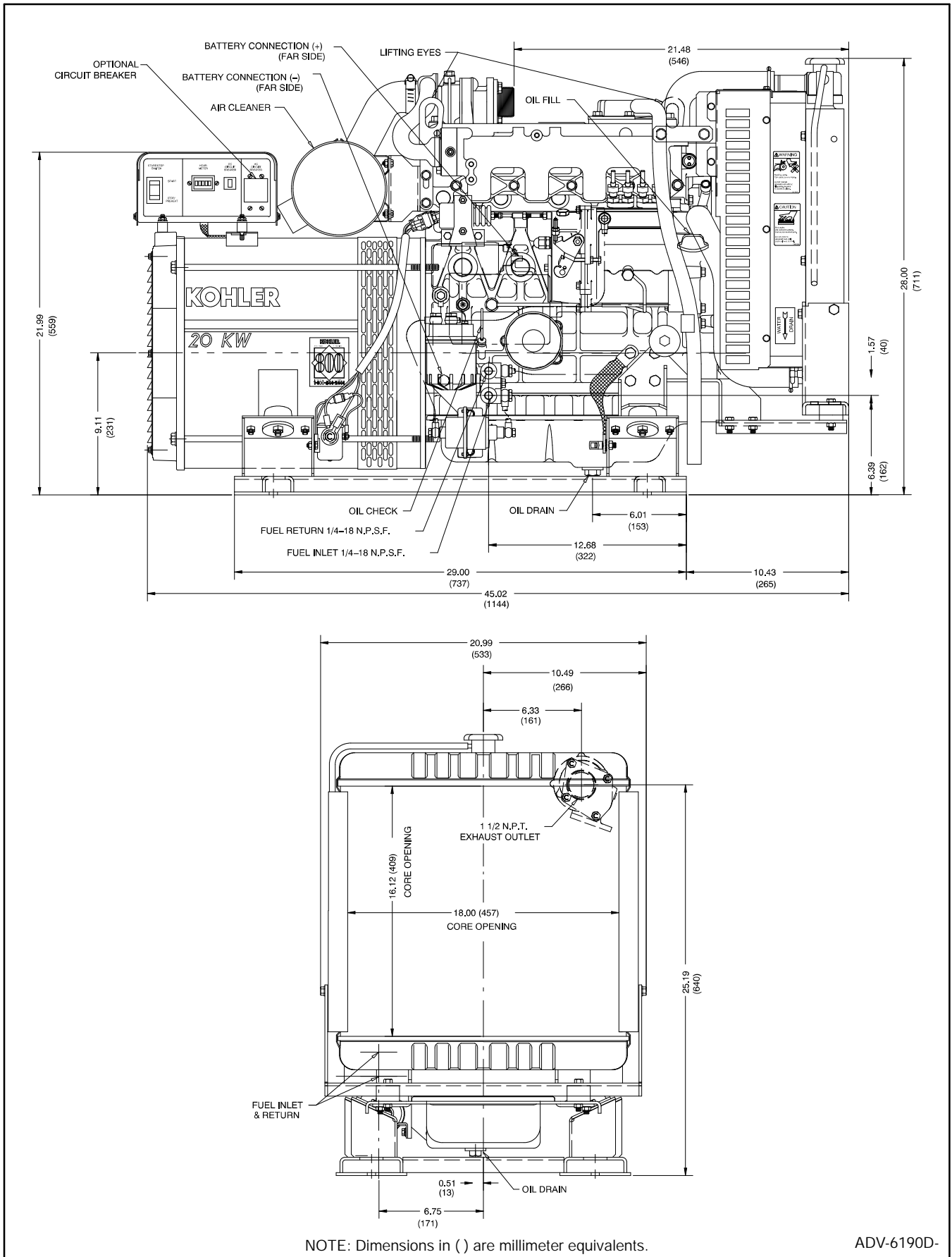

20 kW RV In-line Radiator (spec PA-135322)

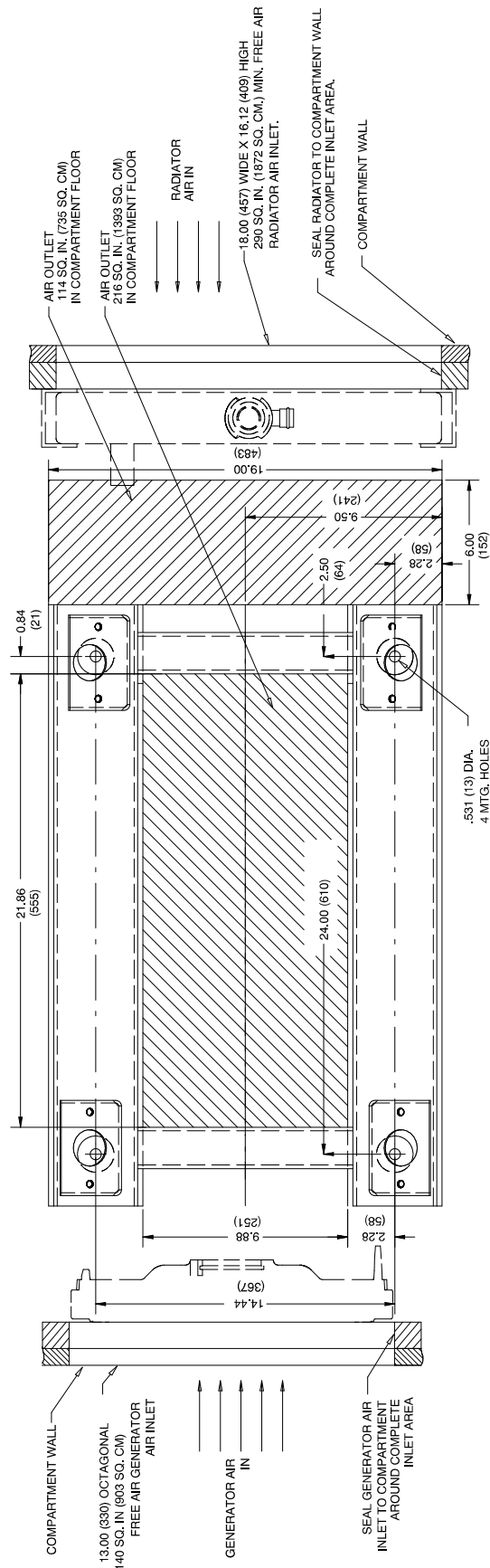

NOTE: Dimensions in () are millimeter equivalents.

ADV-6190D-

20 kW RV In-line Radiator Mounting Pattern (spec PA-135322)

Notes

Appendix A. Glossary of Abbreviations

Abbreviations are used throughout this manual. Normally they will appear in the text in complete form with the abbreviation following in parentheses the first time they are used. After that they will appear in the

abbreviated form. The commonly used abbreviations are shown below. Some items may not apply to this application.

Abbreviation	Description
ABDC	after bottom dead center
AC	alternating current
AISI	American Iron and Steel Institute
AHWT	anticipatory high water temp.
ALOP	anticipatory low oil pressure
AM	amplitude modulation
amp	ampere
amps	amperes
ANSI	American National Standard Institute
API	American Petroleum Institute
approx.	approximate, approximately
A/R	as required, as requested
A/S	as supplied, as stated, as suggested
ASA	American Standards Association (former name of ANSI)
ASME	American Society of Mechanical Engineers
assy.	assembly
ASTM	American Society for Testing Materials
ATDC	after dead top center
aux.	auxiliary
A/V	audio-visual
AWG	American Wire Gage
AWM	appliance wiring material
BBDC	before bottom dead center
BDC	before dead center
BHP	brake horsepower
bmep	brake mean effective power
BTDC	before top dead center
Btu	British thermal unit
°C	Celsius degree
cc	cubic centimeter
CCA	cold cranking amps
CEC	Canadian Electrical Code
cfh	cubic feet per hour
cfm	cubic feet per minute
CID	cubic inch displacement
cm	centimeter, centimeters
cmm	cubic meters per minute
co.	company
cont'd.	continued
CPVC	chloropoly vinyl chloride
CRT	cathode ray tube
CSA	Canadian Standards Association
CT	current transformer
cu. in.	cubic inch (es)

Abbreviation	Description
CWC	city-water cooled
cyl.	cylinder
dB	decibel
dBA	decibels (A weighted)
DC	direct current
DCR	direct current resistance
deg.	degree
dept.	department
dia.	diameter
DIN	Deutsches Institut fur Normung e. V. (also Deutsche Industrie Normenausschuss)
e.g.	example given
EIA	Electronic Industries Association
EMI	electromagnetic interference
EPA	Environmental Protection Agency
etc.	etcetera, (and so forth)
ext.	external
°F	Fahrenheit degree
fl. oz.	fluid ounce(s)
FM	frequency modulation
ft.	foot, feet
ft. lbs.	foot pound(s)
fs	full scale
ga.	gauge (meters wire size)
gal./gals.	gallon, gallons
gph	gallons per hour
gpm	gallons per minute
gr.	grade
grd.	ground
HCHT	high cylinder head temperature
HET	high exhaust temperature
Hg.	mercury (element)
H ₂ O	water
HP	horsepower
hr, hrs	hour, hours
HWT	high water temperature
Hz	hertz (cycles per second)
ID	inside diameter
IEEE	Institute of Electrical and Electronic Engineers
in.	inch, inches
inc.	incorporated
in. lbs.	inch pounds
int.	internal
int.-ext.	internal-external

Abbreviation	Description
ISO	International Standards Organization
J	joule, joules
JIS	Japanese Industry Standard
kg	kilogram, kilograms
kg/cm ²	kilograms per square centimeter
kgm	kilogram meter(s)
kJ	kilojoules (btu cal)
km	kilometer, kilometers
kPa	kiloPascal, kiloPascals
kph	kilometers per hour
kV	kilovolt
kVA	kilovolt amperes
kW	kilowatt, kilowatts
kWH	kilowatt hour
L	liter, liters
LxWxH	length x width x height
LED(s)	light emitting diode(s)
lb., lbs.	pound, pounds
L/hr.	liter per hour, liters per hour
L/min.	liter(s) per minute
LOP	low oil pressure
LP	liquified petroleum
LWT	low water temperature
m	meter, meters
m ³	cubic meter, cubic meters
max.	maximum
MCM	one thousand circular mils.
meggar	megohmmeter
MHz	megahertz
mi.	mile, miles
mil	one one-thousandth of an inch
min.	minimum
misc.	miscellaneous
mJ	milli joule(s)
MJ	mega joule(s)
mm	millimeter
m ³ /min	cubic meters per minute
MPa	megaPascal
mpg	miles per gallon
mph	miles per hour
MS	military standard
mW	milliwatt(s)
MW	megawatt(s)
N/A	not available
NBS	National Bureau of Standards
N.C.	normally closed
NEC	National Electrical Code
NEMA	National Electrical Manufacturers Association
NFPA	National Fire Protection Association
Nm	Newton meter(s)
N.O.	normally open

Abbreviation	Description
no., nos.	number, numbers
NPT	National Standard taper pipe thread per general use
N/R	not required
OC	overcrank
OD	outside diameter
OEM	original equipment manufacturer
OS	overspeed
O/S	oversize
OSHA	Occupational Safety and Health Act
OV	overvoltage
oz.	ounce, ounces
PF	power factor
PMG	permanent magnet generator
pot	potentiometer
ppm	parts per million
psi	pounds per square inch
pt., pts.	pint, pints
PVC	polyvinyl chloride
qt., qts.	quart, quarts
qty.	quantity
ref.	reference
RFI	radio frequency interference
r.h.m.	round-head machine (screw)
rms	root means square
RPM	revolutions per minute
RTV	room temperature vulcanization
SAE	Society of Automotive Engineers
SCR	silicon controlled rectifier
sec.	second, seconds
spec, specs	specification
sq.	square
sq. cm.	square centimeters
sq. in.	square inch(es)
tach	tachometer
TDC	top dead center
tech. pub.	technical publications
temp.	temperature
TIF	telephone influence factor
TP, TPs	technical publications
turbo	turbocharger
UHF	ultrahigh frequency
UNC	Unified coarse thread (was NC)
UNF	Unified fine thread (was NF)
UL	Underwriter's Laboratories, Inc.
U/S	undersize
U.S.A.	United States of America
V	volt, volts
vac	volts alternating current
vdc	volts direct current
VHF	very high frequency
W	watt, watts

TP-5605 4/97a

© Kohler Co., 1997. All rights reserved.

KOHLER[®] POWER SYSTEMS

KOHLER CO. Kohler, Wisconsin 53044
Phone 414-565-3381, Web site www.kohlergenerators.com
Fax 414-459-1646 (U.S.A. Sales), Fax 414-459-1614 (International)
After July 26, 1997, use area code 920 instead of 414
For the nearest sales and service outlet in U.S.A. and Canada
Phone 1-800-544-2444