

# Operation

## Commercial Mobile Generator Sets



Model:

**7ER**  
**6EFR**

**ISO 9001**  
**KOHLER**  
GENERATORS  
INTERNATIONALLY REGISTERED

**KOHLER**<sup>®</sup>  
POWER SYSTEMS

TP-6033 5/99a

---

**California Proposition 65**

** WARNING**

Engine exhaust from this product contains chemicals known to the State of California to cause cancer, birth defects, or other reproductive harm.

---

# Table of Contents

<b>Safety Precautions and Instructions</b> .....	<b>I</b>	3.4 Fuel System .....	9
<b>Introduction</b> .....	<b>i</b>	3.4.1 Fuel Specifications .....	9
<b>Service Assistance</b> .....	<b>i</b>	3.4.2 Carburetor/Choke Lubrication .....	9
<b>Service Parts/Publications</b> .....	<b>ii</b>	3.4.3 Carburetor Adjustment .....	9
<b>Section 1. Service Views</b> .....	<b>1</b>	3.5 Air Cleaner .....	10
<b>Section 2. Operation</b> .....	<b>3</b>	3.6 Exhaust System .....	10
2.1 Prestart Checklist .....	3	3.7 Cooling System .....	11
2.2 Angular Operation .....	3	3.7.1 Checking the Cooling System .....	11
2.3 Exercising the Generator Set .....	3	3.7.2 Draining the Cooling System .....	11
2.4 Starting and Stopping Procedure .....	3	3.7.3 Filling the Cooling System .....	11
2.4.1 Controls and Indicators .....	4	3.7.4 Flushing and Cleaning the Cooling System .....	12
2.4.2 Starting the Generator Set .....	4	3.8 Ignition System .....	13
2.4.3 Remote Panel Gauge Operation .....	4	3.9 Battery .....	15
2.4.4 Stopping the Generator Set .....	4	3.10 Generator Storage Procedure .....	16
<b>Section 3. Scheduled Maintenance</b> .....	<b>5</b>	<b>Section 4. Troubleshooting</b> .....	<b>17</b>
3.1 General Maintenance .....	5	<b>Section 5. Wiring Diagrams</b> .....	<b>21</b>
3.2 Service Schedule .....	6	<b>Appendix A. Glossary of Abbreviations</b> .....	<b>A-1</b>
3.3 Lubrication System .....	8	<b>Appendix B. Operating Hour Service Log</b> .....	<b>B-1</b>
3.3.1 Oil Specifications .....	8		
3.3.2 Oil Check .....	8		
3.3.3 Oil Additions .....	8		
3.3.4 Oil Change .....	8		
3.3.5 Oil Filter Change .....	9		

# Notes

# Safety Precautions and Instructions

Electromechanical equipment, including generator sets, transfer switches, switchgear, and accessories, can cause bodily harm and pose life-threatening danger when improperly installed, operated, or maintained. To prevent accidents be aware of potential dangers and act safely. Read and follow all safety precautions and instructions. **SAVE THESE INSTRUCTIONS.**

This manual has several types of safety precautions and instructions: Danger, Warning, Caution, and Notice.

## DANGER

Danger indicates the presence of a hazard that **will cause severe personal injury, death, or substantial property damage.**

## WARNING

Warning indicates the presence of a hazard that **can cause severe personal injury, death, or substantial property damage.**

## CAUTION

Caution indicates the presence of a hazard that **will or can cause minor personal injury or property damage.**

## NOTICE

Notice communicates installation, operation, or maintenance information that is safety related but not hazard related.

Safety decals affixed to the equipment in prominent places alert the operator or service technician to potential hazards and explain how to act safely. The decals are shown throughout this publication to improve operator recognition. Replace missing or damaged decals.

## Accidental Starting

### WARNING

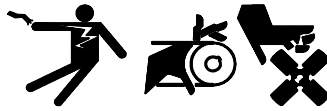

#### **Accidental starting. Can cause severe injury or death.**

Disconnect the battery cables before working on the generator set. Remove the negative (-) lead first when disconnecting the battery. Reconnect the negative (-) lead last when reconnecting the battery.

**Disabling the generator set. Accidental starting can cause severe injury or death.** Before working on the generator set or equipment connected to the set, disable the generator set as follows: (1) Disconnect the power to the battery charger, if equipped. (2) Remove the battery cables, negative (-) lead first. Reconnect the negative (-) lead last when reconnecting the battery. Follow these precautions to prevent the starting of the generator set by the remote start/stop switch.

## Battery

### WARNING



#### **Sulfuric acid in batteries. Can cause severe injury or death.**

Wear protective goggles and clothing. Battery acid may cause blindness and burn skin.

**Battery acid. Sulfuric acid in batteries can cause severe injury or death.** Sulfuric acid in the battery can cause blindness and burn skin. Always wear splashproof safety goggles when working near the battery. If battery acid splashes in the eyes or on the skin, immediately flush the affected area for 15 minutes with large quantities of clean water. Seek immediate medical aid in the case of eye contact. Never add acid to a battery after placing the battery in service, as this may result in hazardous spattering of battery acid.

**Battery gases. Explosion can cause severe injury or death.** Battery gases can cause an explosion. Do not smoke or permit flames or sparks to occur near a battery at any time, particularly when it is charging. To prevent burns and sparks that could cause an explosion, avoid touching the battery terminals with tools or other metal objects. Remove wristwatch, rings, and other jewelry before handling the battery. Never connect the negative (-) battery cable to the positive (+) connection terminal of the starter solenoid. Do not test the battery condition by shorting the terminals together. Sparks could ignite the battery gases or fuel vapors. Ventilate the compartments containing batteries to prevent accumulation of explosive gases. To avoid sparks, do not disturb the battery charger connections while the battery is charging. Always turn the battery charger off before disconnecting the battery connections. Remove the negative (-) lead first when disconnecting the battery. Reconnect the negative (-) lead last when reconnecting the battery.

## Engine Backfire/Flash Fire

<b>⚠ WARNING</b>

<b>Fire.</b> <b>Can cause severe injury or death.</b>
Do not smoke or permit flames or sparks near fuels or the fuel system.

### **Servicing the fuel system. A flash fire can cause severe injury or death.**

Do not smoke or permit flames or sparks near the carburetor, fuel line, fuel filter, fuel pump, or other potential sources of spilled fuels or fuel vapors. Catch fuels in an approved container when removing the fuel line or carburetor.

**Servicing the air cleaner. A sudden backfire can cause severe injury or death.** Do not operate the generator set with the air cleaner removed.

**Combustible materials. A fire can cause severe injury or death.** Generator set engine fuels and fuel vapors are flammable and explosive. Handle these materials carefully to minimize the risk of fire or explosion. Equip the compartment or nearby area with a fully charged fire extinguisher. Select a fire extinguisher rated ABC or BC for electrical fires or as recommended by the local fire code or an authorized agency. Train all personnel on fire extinguisher operation and fire prevention procedures.

## Exhaust System

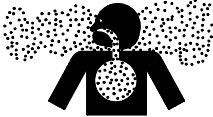
<b>⚠ WARNING</b>

<b>Carbon monoxide.</b> <b>Can cause severe nausea, fainting, or death.</b>
The exhaust system must be leakproof and routinely inspected.

**Generator set operation. Carbon monoxide can cause severe nausea, fainting, or death.** Carbon monoxide is an odorless, colorless, tasteless, nonirritating gas that can cause death if inhaled for even a short time. Avoid breathing exhaust fumes when working on or near the generator set. Never operate the generator set inside a building unless the exhaust gas is piped safely outside. Never operate the generator set where exhaust gas could accumulate and seep back inside a potentially occupied building or vehicle. Do not obstruct the exhaust outlet when parking your vehicle. The exhaust gases must discharge freely to prevent carbon monoxide from deflecting into the vehicle.

**Carbon monoxide symptoms. Carbon monoxide can cause severe nausea, fainting, or death.** Carbon monoxide is a poisonous gas present in exhaust gases. Carbon monoxide poisoning symptoms include but are not limited to the following:

- Light-headedness, dizziness
- Physical fatigue, weakness in joints and muscles
- Sleepiness, mental fatigue, inability to concentrate or speak clearly, blurred vision
- Stomachache, vomiting, nausea

If experiencing any of these symptoms and carbon monoxide poisoning is possible, seek fresh air immediately and remain active. Do not sit, lie down, or fall asleep. Alert others to the possibility of carbon monoxide poisoning. Seek medical attention if the condition of affected persons does not improve within minutes of breathing fresh air.

**Installing the exhaust tail pipe. Carbon monoxide can cause severe nausea, fainting, or death.** Install the exhaust system tail pipe to prevent the drawing of discharged exhaust gases into the vehicle interior through windows, doors, air conditioners, and other openings. Do not use flexible tail piping because it could crack and allow lethal exhaust fumes to enter the vehicle.

**Inspecting the exhaust system. Carbon monoxide can cause severe nausea, fainting, or death.** For the safety of the vehicle's occupants, install a carbon monoxide detector. Consult the coach builder or dealer for approved detector location and installation. Inspect the detector before each generator set use. In addition to routine exhaust system inspection, test the carbon monoxide detector per the manufacturer's instructions and keep the detector operational at all times.

## Fuel System

<b>⚠ WARNING</b>

<b>Explosive fuel vapors.</b> <b>Can cause severe injury or death.</b>
Use extreme care when handling, storing, and using fuels.

**The fuel system. Explosive fuel vapors can cause severe injury or death.** Vaporized fuels are highly explosive. Use extreme care when handling and storing fuels. Store fuels in a well-ventilated area away from spark-producing equipment and out of the reach of children. Never add fuel to the tank while the engine is running because spilled fuel may ignite on contact with hot parts or from sparks. Do not smoke or permit flames or sparks to occur near sources of spilled fuel or fuel vapors. Keep the fuel lines and connections tight and in good condition. Do not replace flexible fuel lines with rigid lines. Use flexible sections to avoid fuel line breakage caused by vibration. Do not operate the generator set in the presence of fuel leaks, fuel accumulation, or sparks. Repair fuel systems before resuming generator set operation.

Explosive fuel vapors can cause severe injury or death. Take additional precautions when using the following fuels:

**Gasoline**—Store gasoline only in approved red containers clearly marked GASOLINE.

**Draining the fuel system. Explosive fuel vapors can cause severe injury or death.** Spilled fuel can cause an explosion. Use a container to catch fuel when draining the fuel system. Wipe up spilled fuel after draining the system.

## Hazardous Noise

### ⚠ CAUTION



**Hazardous noise. Can cause hearing loss.**

Never operate the generator set without a muffler or with a faulty exhaust system.

**Engine noise. Hazardous noise can cause hearing loss.** Generator sets not equipped with sound enclosures can produce noise levels greater than 105 dBA. Prolonged exposure to noise levels greater than 85 dBA can cause permanent hearing loss. Wear hearing protection when near an operating generator set.

## Hazardous Voltage/ Electrical Shock

### ⚠ WARNING

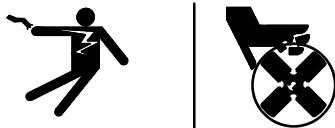

**Hazardous voltage. Moving rotor. Can cause severe injury or death.**

Operate the generator set only when all guards and electrical enclosures are in place.

**Grounding electrical equipment. Hazardous voltage can cause severe injury or death.** Electrocutation is possible whenever electricity is present. Open the main circuit breakers of all power sources before servicing the equipment. Configure the installation to electrically ground the generator set, transfer switch, and related equipment and electrical circuits to comply with applicable codes and standards. Never contact electrical leads or appliances when standing in water or on wet ground because these conditions increase the risk of electrocution.

**Short circuits. Hazardous voltage/current can cause severe injury or death.** Short circuits can cause bodily injury and/or equipment damage. Do not contact electrical connections with tools or jewelry while making adjustments or repairs. Remove wristwatch, rings, and jewelry before servicing the equipment.

**Testing the voltage regulator. Hazardous voltage can cause severe injury or death.** High voltage is present at the voltage regulator heat sink. To prevent electrical shock do not touch the voltage regulator heat sink when testing the voltage regulator. (*PowerBoost™, PowerBoost™ III, and PowerBoost™ V voltage regulator models only*)

**Electrical backfeed to the utility. Hazardous backfeed voltage can cause severe injury or death.** Connect the generator set to the building/campground electrical system only through an approved device and after the building/campground main switch is opened. Backfeed connections can cause serious injury or death to utility personnel working on power lines and/or personnel near the work area. Some states and localities prohibit unauthorized connection to the utility electrical system. Install a transfer switch to prevent interconnection of the generator set power and other sources of power.

## Heavy Equipment

### ⚠ WARNING



**Unbalanced weight. Improper lifting can cause severe injury or death and equipment damage.**

Do not use lifting eyes. Use slings under the skid to balance and lift the generator set.

## Hot Parts

### ⚠ WARNING



**Hot coolant and steam. Can cause severe injury or death.**

Before removing the pressure cap, stop the generator set and allow it to cool. Then loosen the pressure cap to relieve pressure.

### ⚠ WARNING



**Hot engine and exhaust system. Can cause severe injury or death.**

Do not work on the generator set until it cools.



**Checking the coolant level. Hot coolant can cause severe injury or death.** Allow the engine to cool. Release pressure from the cooling system before opening the pressure cap. To release pressure, cover the pressure cap with a thick cloth and then slowly turn the cap counterclockwise to the first stop. Remove the cap after pressure has been completely released and the engine has cooled. Check the coolant level at the tank if the generator set has a coolant recovery tank.



**Servicing the exhaust system. Hot parts can cause severe injury or death.** Do not touch hot engine parts. The engine and exhaust system components become extremely hot during operation.

**Combustible materials. Fire can cause severe injury or death.** A hot exhaust system can ignite adjacent combustible materials. Do not locate electrical wiring, fuel lines, or combustible materials above the exhaust muffler. Exercise caution when parking your vehicle to prevent the exhaust system and hot exhaust gases from starting grass fires.

**Combustible materials. Fire can cause severe injury or death.** A hot generator set can ignite debris in the compartment. Keep the compartment and generator set clean and free of debris and combustible materials to minimize the possibility of fire. Do not block the fuel/oil drain opening in the generator set mounting tray. Cut a corresponding hole in the subfloor, if used, for the drain opening.

### Moving Parts

<b>⚠ WARNING</b>	
	
<b>Hazardous voltage. Moving rotor. Can cause severe injury or death.</b>	
Operate the generator set only when all guards and electrical enclosures are in place.	

<b>⚠ WARNING</b>	
	
<b>Rotating parts. Can cause severe injury or death.</b>	
Operate the generator set only when all guards, screens, and covers are in place.	

**Tightening the hardware. Flying projectiles can cause severe injury or death.** Loose hardware can cause the hardware or pulley to release from the generator set engine and can cause personal injury. Retorque all crankshaft and rotor hardware after servicing. Do not loosen the crankshaft hardware or rotor throbolt when making adjustments or servicing the generator set. Rotate the crankshaft manually in a clockwise direction only. Turning the crankshaft bolt or rotor throbolt counterclockwise can loosen the hardware.

**Servicing the generator set when it is operating. Exposed moving parts can cause severe injury or death.** Keep hands, feet, hair, clothing, and test leads away from the belts and pulleys when the generator set is running. Replace guards, screens, and covers before operating the generator set.

### Notice

<b>NOTICE</b>
This generator set has been rewired from its nameplate voltage to

246242

**NOTICE**  
**Voltage reconnection.** Affix a notice to the generator set after reconnecting the set to a voltage different from the voltage on the nameplate. Order voltage reconnection decal 246242 from an authorized service distributor/dealer.

**NOTICE**  
**Hardware damage.** The engine and generator set may use both American Standard and metric hardware. Use the correct size tools to prevent rounding of the bolt heads and nuts.

**NOTICE**  
**When replacing hardware, do not substitute with inferior grade hardware.** Screws and nuts are available in different hardness ratings. To indicate hardness, American Standard hardware uses a series of markings, and metric hardware uses a numeric system. Check the markings on the bolt heads and nuts for identification.

**NOTICE**  
**Canadian installations only.** For standby service connect the output of the generator set to a suitably rated transfer switch in accordance with Canadian Electrical Code, Part 1.

**NOTICE**  
**This generator set does not comply with United States Coast Guard (USCG) requirements and must not be used for marine applications.** For marine installations use only generator sets specified for marine use. USCG Regulation 33CFR183 requires that a generator set must be ignition protected when used in a gasoline-fueled environment.

# Introduction

---

All information in this publication represents data available at the time of print. Kohler Co. reserves the right to change this literature and the products represented without incurring obligation.

Read through this manual and carefully follow all procedures and safety precautions to ensure proper equipment operation and to avoid bodily injury. Read and follow the Safety Precautions and Instructions section at the beginning of this manual. Keep this manual with equipment for future reference.

Equipment service requirements are minimal yet very important to safe and efficient operation; therefore, inspect parts often and perform required service at the prescribed intervals. Have an authorized service distributor/dealer perform required service to keep equipment in top condition.

At the time of print, this manual applied to the model number listed on the front cover. On occasion this manual may be used for models not listed, such as when similar new models are created after the printing of this manual and prior to the updated reprint or in cases where the manual is deemed an acceptable substitute for a manual under development.

---

**Before installing a mobile generator set, obtain the most current Installation Manual by contacting your local distributor/dealer. Only qualified persons should install the generator set.**

---

## Service Assistance

---

For sales and service in the U.S.A. and Canada check the yellow pages of the telephone directory under the heading GENERATORS—ELECTRIC for an authorized service distributor/dealer or call 1-800-544-2444.

For sales and service outside the U.S.A. and Canada, contact your local distributor.

For further information or questions, contact the company directly at:

KOHLER CO., Kohler, Wisconsin 53044 U.S.A.  
Phone: 920-565-3381  
Fax: 920-459-1646 (U.S.A. Sales)  
920-459-1614 (International)

To ensure supply of correct parts or information, make note of the following identification numbers in the spaces provided:

### GENERATOR SET

MODEL, SPEC, and SERIAL numbers are found on the nameplate attached to the generator set.

Model No. \_\_\_\_\_

Specification No. \_\_\_\_\_

Serial No. \_\_\_\_\_

### ENGINE

The engine serial number is found on the engine nameplate.

Engine Serial No. \_\_\_\_\_

# Service Parts/Publications

---

## Routine Service Parts

The following table contains a list of recommended spare parts. Contact your Kohler generator distributor/dealer for a complete list of service parts for your generator set.

Part Description	Part Number
Air Cleaner Foam Element	359894
Air Cleaner Paper Element	359895
Battery Charging Fuse (25 amp)	262389
Input Fuse (10 amp)	223316
Oil Filter	359771
Spark Plug	359979
Spray Paint (Black)	221292
Voltage Regulator Fuse (10 amp)	223316

## List of Related Literature

The following table identifies the literature available for the generator sets covered in this manual. Only qualified persons should install or service the generator set.

Literature Type	Part Number
Installation Manual	TP-6034
Operation Manual (Generator)	TP-6033
Operation Manual (Engine)	TP-6001
Parts Catalog*	TP-6036
Service Manual (Generator)	TP-6035
Service Manual (Engine)	TP-6002
Service Manual Supplement (Engine)	TP-6008

\* One manual combines the generator and engine information.

# Section 1. Service Views

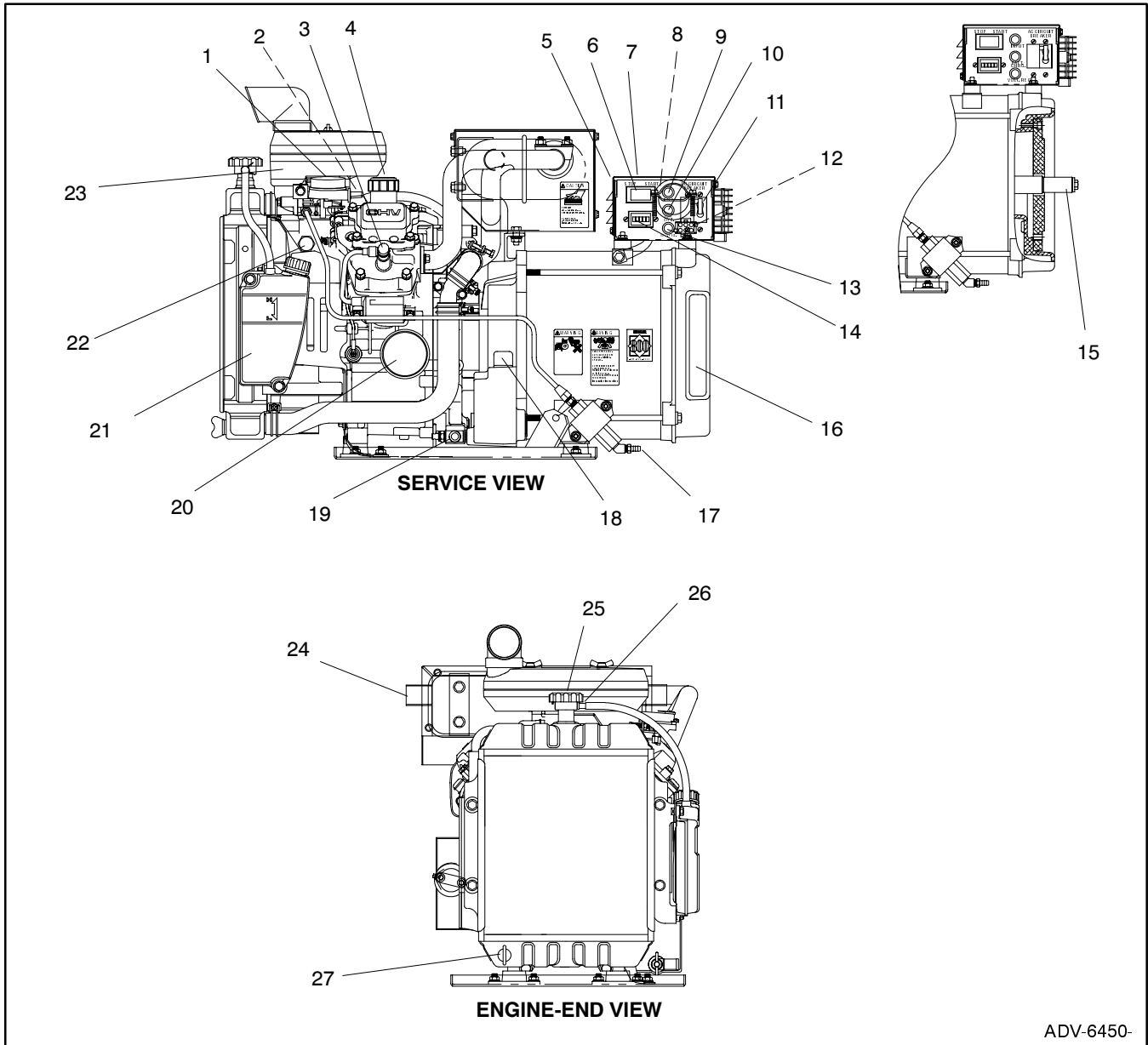

1. Electric choke (on carburetor)
2. Carburetor/choke linkage
3. Spark plugs (also one on nonservice side)
4. Oil fill
5. Controller
6. Start/Stop switch
7. Nameplate (top)
8. AC load lead connector (nonservice side)
9. Input fuse
10. Battery charging fuse
11. AC circuit breaker
12. Remote start connector (nonservice side)
13. Voltage regulator fuse
14. Hourmeter
15. Extended shaft (generator specification available)
16. Cooling air inlet

17. Fuel feed pump (fuel inlet)
18. Oil check
19. Oil-drain valve
20. Lube oil filter
21. Coolant overflow bottle (daily coolant check/fill location)
22. Antidieseling solenoid (on carburetor)
23. Air cleaner
24. Exhaust outlet
25. Pressure cap (coolant fill location after draining coolant)
26. Overflow tube
27. Coolant-drain valve

**Note:** Consult the installation drawings in the spec sheet or installation manual for the fuel- and battery-connection points.

**Note:** Consult the distributor/dealer or service manual for items not shown.

**Figure 1-1. Service Views**

# Notes

### 2.1 Prestart Checklist

To ensure continued satisfactory operation, check the following items before each startup and at regular intervals according to the service schedule.

**Air Cleaner.** Keep the air cleaner element clean. Install the element to keep unfiltered air from entering the engine.

**Air Inlets.** Keep the air inlets clean and unobstructed.

**Battery.** Ensure tight battery connections. Consult the battery manufacturer's instructions regarding battery care and maintenance.

**Coolant Level.** Maintain adequate coolant level.

**Exhaust System.** Keep the exhaust outlet clear. Keep the muffler and piping tight and in good condition.

Inspect the exhaust system components for cracks and corrosion (exhaust outlet, exhaust line, exhaust clamps, and muffler).

- Check for corroded metal parts and replace them as needed.
- Check for loose, corroded, or missing clamps. Tighten or replace the exhaust clamps as needed.
- Check that the exhaust outlet is clear.
- Check the exhaust gas condition. If the exhaust is blue or black, contact your local distributor/dealer.
- Ensure that the carbon monoxide detector is (1) in the vehicle, (2) operational, and (3) in the ON position whenever the generator set is in use.

**Fuel Level.** Keep the tank(s) full to ensure adequate fuel supply.

**Oil Level.** Maintain adequate oil level.

**Operating Area.** Check for obstructions that could block the flow of combustion air. Keep the air intake area clean. Do not leave rags, tools, or debris on or near the generator set.

### 2.2 Angular Operation

Angular operation on this unit is 25° continuous/30° intermittent—3 minutes or less (max. in all directions).

### 2.3 Exercising the Generator Set

Run the generator set under load once each week for one hour with an operator present.

Perform all of the prestart checks before starting the exercise procedure. Start the generator set according to the starting procedure. While running the generator set, listen for a smooth-running engine and visually inspect the generator set to ensure that there are no fluid or exhaust leaks.

### 2.4 Starting and Stopping Procedure

---

#### NOTE

**Starter motor cooldown.** Do not crank the engine continuously for more than 10 seconds at a time. Allow a 60-second cooldown period between cranking attempts if the engine does not start. If the unit fails to start after three attempts, contact an authorized Kohler distributor/dealer for repair. Failure to follow these guidelines may result in starter motor burnout.

#### NOTE

**Engine restart.** If the engine starts and then stops, allow the engine to come to a complete stop before making a restart attempt. If the flywheel ring gear is still rotating when the starter pinion gear is engaged, the pinion gear will clash, which may damage the ring gear teeth.

---

### 2.4.1 Controls and Indicators

The following table describes the controls and indicators located at the controller.

Name	Description
Start/Stop Switch	Use this switch to start and stop the generator set. Press the switch to the start position to start the generator set. Press the switch to the stop position to stop the generator set.
AC Circuit Breaker	The circuit breaker trips when a fault occurs in the output circuit. During maintenance of the vehicle wiring, the circuit breaker disconnects the generator set. Place the circuit breaker in the ON position to close the circuit breaker.
Input Fuse	This fuse protects the controller circuitry.
Battery Charging Fuse	This fuse protects the battery charging circuitry.
Voltage Regulator Fuse	This fuse protects the voltage regulator circuitry.
Remote Start Connector	A 6-pin connector on the controller back panel allows connection of the (optional) remote start kits.
Hourmeter	This meter records the total generator set operating hours for reference in maintenance scheduling.

### 2.4.2 Starting the Generator Set

The following table describes the action required to start the generator set.

Action
<b>Starting</b> Place the generator set controller start/stop switch or the remote start/stop switch in the start position.

### 2.4.3 Remote Panel Gauge Operation

If the generator set has an optional remote panel with gauges, observe the gauges upon engine startup. If the gauge readings are not within the ranges specified, see the following table, contact an authorized service distributor/dealer.

Gauge	Normal Operating Range
Oil pressure	40-60 psi (276-414 kPa)
Water temperature	160-182°F (71-83°C)
DC voltmeter	12-14 volts

### 2.4.4 Stopping the Generator Set

The following table describes the actions required to stop the generator set.

Step	Action
1	<b>Cooldown</b> Run the generator set at no load for 5 minutes to ensure adequate engine cooldown.
2	<b>Stopping</b> Place the controller start/stop switch or remote start/stop switch in the stop position and wait until the generator set comes to a complete stop.

## Section 3. Scheduled Maintenance

### 3.1 General Maintenance

#### WARNING

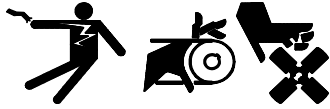

#### **Accidental starting. Can cause severe injury or death.**

Disconnect the battery cables before working on the generator set. Remove the negative (-) lead first when disconnecting the battery. Reconnect the negative (-) lead last when reconnecting the battery.

**Disabling the generator set. Accidental starting can cause severe injury or death.** Before working on the generator set or equipment connected to the set, disable the generator set as follows: (1) Disconnect the power to the battery charger, if equipped. (2) Remove the battery cables, negative (-) lead first. Reconnect the negative (-) lead last when reconnecting the battery. Follow these precautions to prevent the starting of the generator set by the remote start/stop switch.

#### WARNING

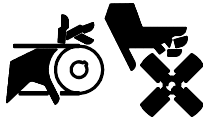

#### **Rotating parts. Can cause severe injury or death.**

Operate the generator set only when all guards, screens, and covers are in place.

**Servicing the generator set when it is operating. Exposed moving parts can cause severe injury or death.** Keep hands, feet, hair, clothing, and test leads away from the belts and pulleys when the generator set is running. Replace guards, screens, and covers before operating the generator set.

#### NOTICE

**Hardware damage.** The engine and generator set may use both American Standard and metric hardware. Use the correct size tools to prevent rounding of the bolt heads and nuts.

**Engine Service.** Perform the generator set engine service at the intervals specified by the engine literature.

**Generator Set Service.** If the generator set operates under dusty or dirty conditions, use *dry* compressed air to blow dust out of the generator. With the generator set running, direct the stream of air in through the cooling slots at the generator end.

See the Safety Precautions and Instructions at the beginning of this manual before attempting to service, repair, or operate the generator set. Have an authorized Kohler service distributor/dealer perform all generator service.

**Routine Maintenance.** Refer to the service schedule following and the hourmeter located on the generator set controller to schedule routine maintenance. Service units subject to extreme weather, long operating hours, or dusty or dirty conditions more frequently.

**Service Log.** Use the Operating Hour Service Log located in the back of this manual to document performed services.

**Service Schedule.** Perform maintenance on each item in the service schedule at the designated interval for the life of the generator set. For example, an item requiring service every 100 hours or 3 months also requires service after 200 hours or 6 months, 300 hours or 9 months, and so on.

**Tools.** The tools and instruments to perform some maintenance items are not generally available to the generator set owner. Therefore, have service performed by an authorized distributor/dealer.

### 3.2 Service Schedule

Perform Service at Intervals Indicated (X)	Reference Section	Before Starting	After 50 Hrs or 1 Month	Every 100 Hrs or 3 Months	Every 400 Hrs or 6 Months	Every 500 Hrs or Yearly
<b>FUEL SYSTEM</b>						
Check the fuel level and fill as necessary	2.1	X				
Lubricate the carburetor and choke linkage	3.4.2			X (200 hrs)		
Check the fuel lines and replace them as necessary *					X (300 hrs)	
<b>LUBRICATION SYSTEM</b>						
Check the crankcase oil level and add oil as necessary	3.3.2	X				
Replace the oil in the crankcase	3.3.4		X (20 hrs break-in period)	X		
Replace the lube oil filter element	3.3.5		X (20 hrs break-in period)	X (200 hrs)		
<b>COOLING SYSTEM</b>						
Check the coolant level and fill as necessary	3.7	X				
Inspect the radiator and hoses	3.7.1			X (200 hrs)		
Flush the cooling system *	3.7.4				X	
<b>IGNITION SYSTEM</b>						
Clean and regap the spark plugs	3.8			X		
Replace the spark plugs	3.8				X (300 hrs)	
<b>INTAKE/EXHAUST SYSTEM</b>						
Inspect the exhaust system components *	3.6	X				
Check the exhaust gas condition	3.6	X (during operation)				
Clean the air cleaner's foam element	3.5		X (25 hrs)			
Clean the air cleaner's paper element	3.5			X		
Replace the air cleaner's paper element	3.5					X (300 hrs)
Check the crankcase breather pipe for obstructions *					X	
Inspect the complete exhaust system *						X

\* Consult your local distributor/dealer for service.

## Service Schedule, continued

Perform Service at Intervals Indicated (X)	Reference Section	Before Starting	After 50 Hrs or 1 Month	Every 100 Hrs or 3 Months	Every 400 Hrs or 6 Months	Every 500 Hrs or Yearly
<b>ELECTRICAL SYSTEM</b>						
Keep the battery charged and in good condition †	3.9	X				
Check and tighten the electrical connections			X			
Clean the battery cables *				X (200 hrs)		
<b>ENGINE AND MOUNTING</b>						
Check for water, fuel, coolant, and oil leakage *‡		X				
Retighten all nuts and bolts		X				
Check tightness of the mounting bolts/vibromounts				X (200 hrs)		
Check and adjust the valve clearance *					X (300 hrs)	
Clean the combustion chamber *					X (300 hrs)	
<b>REMOTE CONTROL SYSTEM</b>						
Check the remote control operation	2.4.3		X (break-in period)			X
<b>GENERATOR</b>						
Test run the generator set	2.3		X (weekly)			
Blow dust out of the generator *	3.1					X
<b>COMPARTMENT</b>						
Remove loose debris from the compartment	2.1	X				

\* Consult your local distributor/dealer for service.

† Consult the battery manufacturer's instructions.

‡ Read the WARNING found at the beginning of this manual regarding moving parts.

### 3.3 Lubrication System

#### 3.3.1 Oil Specifications

Use oil that meets the American Petroleum Institute (API) classification of SC, SD, SE, SF, SG, or SH. Using an unsuitable oil or neglecting an oil change may result in engine damage that is not covered by the engine warranty. Figure 3-1 shows the recommended Society of Automotive Engineers (SAE) viscosity designation for given operating temperature ranges.

Do not mix different oil brands. Incompatibility could cause a breakdown of the lubricating ingredients and reduce the engine protection.

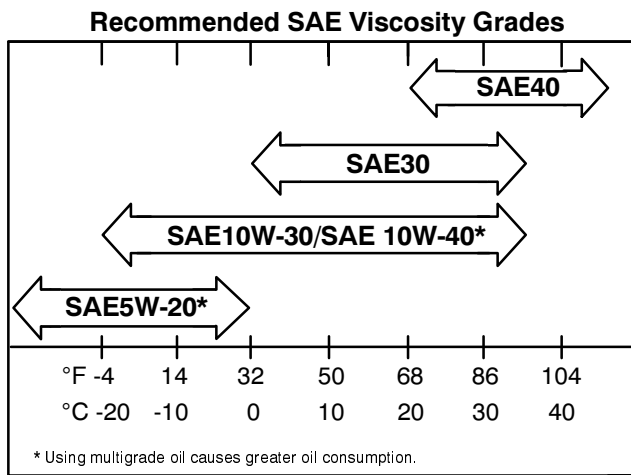
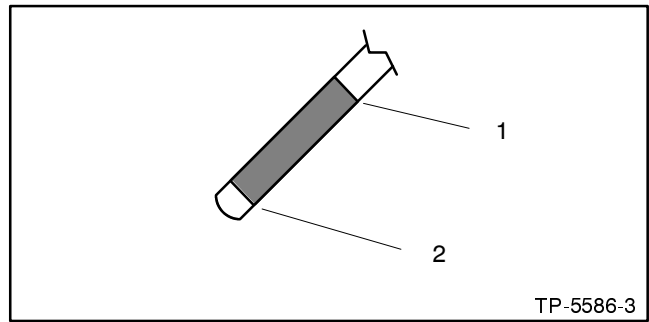

Figure 3-1. Engine Oil Selection

#### 3.3.2 Oil Check

Check the oil level in the crankcase daily or before each startup to ensure that the level is in the safe range. Do not check the oil level while operating the unit. Stop the generator set and keep the generator set level to get an accurate reading. To check the oil level, remove the dipstick and wipe the end clean. Reinsert the dipstick and remove it. Maintain the oil level between the Full and Add marks on the dipstick, as shown in Figure 3-2. See Section 1—Service Views for the dipstick location.



1. Full mark
2. Add mark

Figure 3-2. Oil Level Check

#### NOTE

Do not operate the set if the oil level is below the Add mark on the dipstick or above the Full mark on the dipstick.

#### 3.3.3 Oil Additions

Adding some oil between oil changes is normal. The amount varies with the generator set usage. Open the oil fill cap and pour in a small amount of oil using a funnel or other suitable pouring device. See Section 1—Service Views for the oil check and oil fill locations.

#### 3.3.4 Oil Change

Change the oil according to the service schedule or before generator set storage. Change the oil more frequently under dirty, dusty conditions. Change the oil while the engine is still warm. See Figure 3-3 for the oil capacity. See Section 1—Service Views for the oil fill, oil check, and oil filter locations.

Qts. (L)
1.44 (1.36)

Figure 3-3. Oil Capacity (with Filter)

## Oil Change Procedure

1. Stop the generator set.
2. To drain the oil, open the oil drain valve. See Section 1 for the oil drain valve location.
3. Drain the oil into a suitable container.
4. Allow ample time for all of the oil to drain.
5. Close the oil drain valve.
6. Remove the oil fill cap.
7. Replace the engine oil filter according to the service schedule and the following procedure.
8. Fill the engine crankcase with oil. Section 1 shows the oil fill location. See Figure 3-1 for oil selection and Figure 3-3 for oil capacity. Replace the oil fill cap.
9. Start the generator set and check for oil leaks.
10. Stop the generator set. Check the oil level. Add oil, as necessary, to bring the level up to the Full mark.

---

### NOTE

Too high an oil level causes high oil consumption and engine carbonizing. Too low a level damages the engine.

### NOTE

Do not pollute the environment. Dispose of used engine oil and other contaminants in a safe, approved manner.

---

## 3.3.5 Oil Filter Change

Replace the oil filter at the interval specified in the service schedule. Change the oil filter more frequently under dirty, dusty conditions. Refer to the following procedure. See Section 1 for the oil filter location.

### Oil Filter Change Procedure

1. Loosen the oil filter by turning it counterclockwise. Remove the oil filter and use rags to clean up spilled oil. Dispose of the oil filter in an approved manner.
2. Clean the contact surface of the oil filter adapter.

3. Lightly lubricate the gasket surface of the new filter with fresh engine oil. Thread the filter on the adapter until the gasket makes contact and hand-tighten an additional one-half turn. Wash hands after any contact with the engine oil.

If also performing an oil change, skip steps 4 and 5 and go back to the oil change procedure.

4. Start the generator set and check for oil leaks.
5. Stop the generator set. Check the oil level. Add oil, as necessary, to bring the level up to the Full mark.

## 3.4 Fuel System

### 3.4.1 Fuel Specifications

Use a clean, good quality unleaded fuel with an octane number of 87. Use fresh gasoline to ensure it is blended for the season and to reduce the possibility of the formation of gum deposits that could clog the fuel system. Do not use gasoline left over from the previous season.

Kohler Co. recommends unleaded fuel because it leaves fewer combustion chamber deposits. Never mix oil with fuel.

---

### NOTE

Consult the engine owner's manual for oxygenated fuel recommendations.

---

### 3.4.2 Carburetor/Choke Lubrication

At the interval specified in the service schedule, lubricate the carburetor and choke linkage using a light oil. See Section 1 for the carburetor and choke linkage location.

### 3.4.3 Carburetor Adjustment

The carburetor is factory set. No adjustments are possible.

### 3.5 Air Cleaner

At the intervals specified in the service schedule clean or replace the air cleaner elements. Clean the elements more frequently in dirty, dusty conditions. Check the elements for accumulated oil or dirt that could cause poor performance. See Section 1 for the air cleaner location. Replace a damaged air cleaner element. Follow the procedures described below.

#### Air Cleaner Foam Element Cleaning Procedure

1. Loosen the two wing nuts located on the top of the air cleaner.
2. Lift off the air cleaner cover.
3. Remove the foam element.
4. Wash the foam element in a mild detergent and water solution. Rinse and air dry.
5. Soak the foam element in new engine oil and squeeze the element to remove excess oil.
6. Reassemble using the reverse sequence.

#### Air Cleaner Paper Element Cleaning Procedure

1. Loosen the two wing nuts located on the top of the air cleaner.
2. Lift off the air cleaner cover.
3. Remove the paper air cleaner element.
4. Tap the element lightly against a flat surface to dislodge loose surface dirt.

---

#### NOTE

Do not clean the paper element in liquid or blow out debris with compressed air.

---

5. Reassemble using the reverse sequence.

### 3.6 Exhaust System

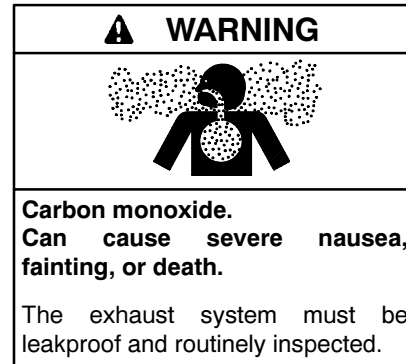

**Inspecting the exhaust system. Carbon monoxide can cause severe nausea, fainting, or death.** For the safety of the vehicle's occupants, install a carbon monoxide detector. Consult the coach builder or dealer for approved detector location and installation. Inspect the detector before each generator set use. In addition to routine exhaust system inspection, test the carbon monoxide detector per the manufacturer's instructions and keep the detector operational at all times.

#### Exhaust System Inspection Points

At the interval specified in the service schedule, inspect the exhaust system. See Section 1 for the exhaust outlet location. Inspect the exhaust system components for cracks and corrosion (exhaust outlet, exhaust line, exhaust clamps, and muffler).

- Check for corroded metal parts and replace them as needed.
- Check for loose, corroded, or missing clamps. Tighten or replace the exhaust clamps as needed.
- Check that the exhaust outlet is clear.
- Check the exhaust gas condition. If the exhaust is blue or black, contact your local distributor/dealer.
- Ensure that the carbon monoxide detector is (1) in the habitable area of the vehicle, (2) operational, and (3) in the ON position whenever the generator set is in use.

## 3.7 Cooling System

### 3.7.1 Checking the Cooling System

<b>⚠ WARNING</b>

<p><b>Hot coolant and steam. Can cause severe injury or death.</b></p> <p>Before removing the pressure cap, stop the generator set and allow it to cool. Then loosen the pressure cap to relieve pressure.</p>

**Checking the coolant level. Hot coolant can cause severe injury or death.** Allow the engine to cool. Release pressure from the cooling system before opening the pressure cap. To release pressure, cover the pressure cap with a thick cloth and then slowly turn the cap counterclockwise to the first stop. Remove the cap after pressure has been completely released and the engine has cooled. Check the coolant level at the tank if the generator set has a coolant recovery tank.

To prevent generator shutdown or damage because of overheating, keep the cooling air inlets clean and unobstructed at all times. Inspect the radiator's exterior for obstructions and remove dirt and foreign material with a soft brush or cloth to avoid damaging the radiator fins. Check the hoses and connections for leaks and replace any cracked, frayed, or spongy hoses. When checking the coolant level, also check the rubber seal of the radiator's pressure cap and replace a cracked or deteriorated cap. The pressure cap raises the boiling point of the coolant, enabling higher operating temperatures. If the cap leaks, replace it with the same rating type of cap. Find the pressure cap rating in Figure 3-4. Remove dirt and other debris from the pressure cap and filler neck. See Figure 3-5 for the coolant capacity.

Component	Rating psi (kPa)
Pressure Cap Rating	12 to 14 (83 to 96)

Figure 3-4. Pressure Cap Rating

Qts. (L)
2.2 (2.08)

Figure 3-5. Coolant Capacity

### 3.7.2 Draining the Cooling System

The radiator contains a coolant drain valve to drain the cooling system. When draining the coolant, remove the radiator's pressure cap; this will allow the entire system to drain and will prevent air pockets from forming and restricting coolant passage to the block.

---

#### NOTE

Pay special attention to the coolant level. After the coolant drains, allow time for complete refill of the engine water jacket.

---

### 3.7.3 Filling the Cooling System

1. Close the radiator's coolant drain valve and tighten the hose clamps.

---

#### NOTE

Do not add coolant to a hot engine. Adding coolant to a hot engine can cause the cylinder block or cylinder head to crack. Wait until the engine has cooled.

---

2. Fill the radiator with the recommended coolant mixture of 50% ethylene glycol and 50% clean, softened water to inhibit rust/corrosion and prevent freezing.

---

**NOTE**

A coolant solution of 50% ethylene glycol provides freezing protection to  $-34^{\circ}\text{F}$  ( $-37^{\circ}\text{C}$ ) and overheating protection to  $265^{\circ}\text{F}$  ( $129^{\circ}\text{C}$ ). A coolant solution with less than 50% ethylene glycol may not provide adequate freezing and overheating protection. A coolant solution with more than 50% ethylene glycol can cause engine or component damage. Do not use alcohol or methanol antifreeze or mix them with the specified coolant. Consult the engine manufacturer's operation manual for engine coolant specifications.

---

3. Replace the radiator's pressure cap.
4. Operate the engine until the thermostat opens and the radiator upper hose becomes hot.
5. Stop the engine and allow it to cool.
6. Remove the radiator's pressure cap.
7. Add coolant to the radiator to just below the overflow tube on the filler neck. See Section 1 for the overflow tube location.
8. Replace the radiator's pressure cap.
9. Maintain coolant level in the coolant overflow bottle between the High and Low markings. See Section 1 for the coolant overflow bottle location.

---

**NOTE**

Periodically check the coolant level by removing the radiator's pressure cap. Do not rely solely on the level in the coolant overflow bottle. Add fresh coolant until the level is just below the overflow tube opening.

---

### 3.7.4 Flushing and Cleaning the Cooling System

For optimum protection, drain, flush, and refill the cooling system at the interval listed in the service schedule.

1. Open the radiator's coolant drain valve and allow the system to drain completely.
2. Remove the radiator's pressure cap to simplify draining.
3. Drain, clean, and flush the coolant overflow bottle.
4. Flush the system with clean water.
5. Close the radiator's coolant drain valve.
6. Fill the cooling system with the recommended coolant.
7. Replace the radiator's pressure cap.

### 3.8 Ignition System

Service the spark plugs at the interval specified in the service schedule using the following procedure.

#### Spark Plug Service Procedure

1. Remove the spark plug wires by grasping the spark plug boot and turning it slightly while pulling. Do not pull the wire. Pulling on the wire rather than the boot may damage the wire or the terminal.
2. Loosen the spark plug with a ratchet and 5/8 in. spark plug socket with a rubber insert to prevent spark plug damage.

3. Use compressed air to remove dirt from around each spark plug to prevent dirt particles from falling into the combustion chamber.
4. Remove the spark plugs one at a time and examine each plug. Identify a normal spark plug in good operating condition by observing a light tan or gray deposit on the firing tip. See Figure 3-6 to evaluate the engine condition by color/condition of a problem spark plug.

Problem/Condition	Means of Identification	Possible Cause/Solution
<b>Gap-bridged spark plug</b>	Built-up deposits and gap between the electrodes closing	Oil or carbon fouling. Clean and regap the spark plug.
<b>Oil-fouled spark plug</b>	Wet, black deposits on the insulator shell, bore, and electrode	Excessive oil entering the combustion chamber through the worn rings and pistons, excessive clearance between valve guides and stems, or worn or loose bearings. Replace the spark plug.
<b>Carbon-fouled spark plug</b>	Black, dry, fluffy carbon deposits on the insulator tips, exposed shell surfaces, and electrodes	Incorrect spark plug, weak ignition, clogged air intake, defective fuel pump, overrich fuel mixture, or excessive no-load operation. Clean and regap the spark plug.
<b>Lead-fouled spark plug</b>	Dark gray, black, yellow, or tan deposits; a glazed coating on the insulator tip	Caused by highly leaded fuel. Replace the spark plug.
<b>Preignition-damaged spark plug</b>	Melted electrodes and possibly blistered insulator. Metallic deposits on the insulator suggest internal engine damage	Wrong type of fuel, incorrect timing or advance, too hot a plug, burned valves, or engine overheating. Replace the spark plug.
<b>Overheated spark plug</b>	White or light gray insulator with small black or gray/brown spots with bluish (burned) appearance on the electrodes	Engine overheating, wrong type of fuel, loose spark plugs, too hot a plug, low fuel pump pressure, or incorrect ignition timing. Replace the spark plug.
<b>Worn spark plug</b>	Severely eroded or worn electrodes	Caused by normal wear and failure to replace spark plug at prescribed interval. Replace the spark plug.

**Figure 3-6. Engine Evaluation Using Spark Plug Condition**

5. Clean the spark plugs by wiping them with a rag. File the center electrode to keep it parallel to the side electrode.

---

**NOTE**

Do not sandblast, wire brush, scrape, or otherwise service a spark plug in poor condition. Obtain a new plug for the best results.

---

6. Check the spark plug gap before installing any spark plug. See Figure 3-7. Attain a correct gap when the feeler (or wire) passes between the spark plug electrode. It should pass easily but with some resistance or drag; otherwise adjust as necessary. The correct gap is 0.024–0.028 in. (0.6–0.7 mm).

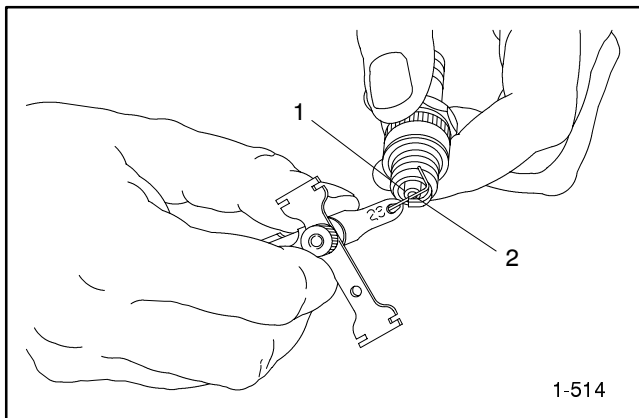

1. 0.024–0.028 in. (0.6–0.7 mm) gap
2. Spark plug electrodes

**Figure 3-7. Spark Plug Gap Inspection**

7. Use a gapping tool to gently bend the side electrode closer to or farther from the center electrode to set the correct gap. See Figure 3-8. Position the side electrode directly over the center electrode.

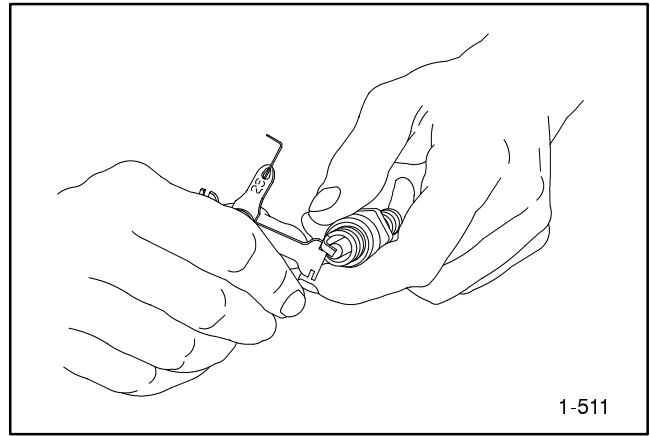

**Figure 3-8. Spark Plug Gap Adjustment**

8. Reinstall the spark plug. Do not bump the electrode against the cylinder head. Rotate the spark plug clockwise until feeling resistance.
9. Use a torque wrench to torque each spark plug to 9–12 ft. lbs. (12–17 Nm). Otherwise, hand-tighten the spark plug until feeling resistance.
10. Use a ratchet wrench to final tighten an additional 1/4 turn. Do not overtighten, as doing so may strip threads or alter the electrode gap setting.
11. Check the spark plug wire connector in the boot for accumulated dirt, grease, and other debris, and clean as necessary.
12. Firmly push the spark plug boot onto the spark plug.

### 3.9 Battery

Consult the battery manufacturer's instructions regarding battery care and maintenance.

---

**⚠ WARNING**



**Sulfuric acid in batteries.  
Can cause severe injury or death.**

Wear protective goggles and clothing. Battery acid may cause blindness and burn skin.

---

**Battery acid. Sulfuric acid in batteries can cause severe injury or death.** Sulfuric acid in the battery can cause blindness and burn skin. Always wear splashproof safety goggles when working near the battery. If battery acid splashes in the eyes or on the skin, immediately flush the affected area for 15 minutes with large quantities of clean water. Seek immediate medical aid in the case of eye contact. Never add acid to a battery after placing the battery in service, as this may result in hazardous spattering of battery acid.

**Battery gases. Explosion can cause severe injury or death.** Battery gases can cause an explosion. Do not smoke or permit flames or sparks to occur near a battery at any time, particularly when it is charging. To prevent burns and sparks that could cause an explosion, avoid touching the battery terminals with tools or other metal objects. Remove wristwatch, rings, and other jewelry before handling the battery. Never connect the negative (-) battery cable to the positive (+) connection terminal of the starter solenoid. Do not test the battery condition by shorting the terminals together. Sparks could ignite the battery gases or fuel vapors. Ventilate the compartments containing batteries to prevent accumulation of explosive gases. To avoid sparks, do not disturb the battery charger connections while the battery is charging. Always turn the battery charger off before disconnecting the battery connections. Remove the negative (-) lead first when disconnecting the battery. Reconnect the negative (-) lead last when reconnecting the battery.

### 3.10 Generator Storage Procedure

Follow the procedure below when storing the generator set for a long period (3 months or more).

1. Start and run the generator set until it reaches operating temperature or about 15 minutes.
2. Stop the generator set.
3. Change the oil and oil filter; see Section 3.3.4—Oil Change and Section 3.3.5—Oil Filter Change.
4. Drain the fuel completely from the fuel tank and carburetor to prevent accumulated moisture from mixing with the fuel.
5. Check the engine coolant protection; see Section 3.7.

---

#### NOTE

Use antifreeze capable of withstanding the lowest possible temperatures.

---

6. Remove the spark plugs. Pour approximately 0.06–0.1 cu. in. (1–1.6 cc) of engine oil into each spark plug hole. Crank the engine two or three revolutions to lubricate the cylinders. Reinstall the spark plugs.

7. Clean the exterior of the generator set and spread a light film of oil or silicon spray over exposed surfaces that may be subject to rust or corrosion.
8. Seal the air inlet, exhaust pipe, and fuel tank cap with tape.
9. Disconnect and remove the battery. Place the battery in a warm, dry location for the storage period. Recharge once a month to maintain full charge.
10. Select a well-ventilated (not humid or dusty) location to store the generator.
11. Cover the entire unit with a dust cover.

---

#### NOTE

Run the generator set once a month whenever possible.

---

## Section 4. Troubleshooting

When troubles occur, do not overlook simple causes. Improper fuel or an empty fuel tank could cause a starting problem. The following charts list some common problems. If procedures in this manual do not

explain how to correct the problem, take the generator set to an authorized service distributor/dealer. Tell the dealer exactly what happened when the problem occurred and any adjustments made to the set.

<b>Engine</b>		
<b>Problem</b>	<b>Possible Cause</b>	<b>Corrective Action</b>
<b>Unit does not crank</b>	Weak or dead battery	Recharge or replace the battery*
	Reversed or poor battery connections. Poor ground.	Check and correct the connections*
	Fuse blown in controller	Replace the fuse
	Inoperative start/stop switch	Check the switch; replace as necessary*
	Inoperative starter solenoid	Check the starter solenoid and wiring. Replace as necessary.*
	Inoperative starter	Replace/repair as necessary*
<b>Unit cranks but does not start</b>	Fault shutdown	Check the shutdown switches*
	No fuel	Replenish the fuel
	Bad fuel mixture	Replace the fuel; clean the carburetor*
	Inoperative fuel feed pump	Replace the fuel feed pump*
	Incorrect type of fuel	Use correct type of fuel; consult the fuel supplier
	Flooded carburetor	Wait a few minutes and attempt restart
	Loose spark plug connection	Reconnect the spark plug wires
	Faulty spark plug(s)	Replace and regap the spark plug(s)
	Inoperative ignition module	See an authorized Kohler service distributor/dealer
	Incorrect type of crankcase lube oil for ambient temperature	Use the correct lube oil
	Faulty antidieseling solenoid	Replace the solenoid*
	Clogged air cleaner	Clean or replace the air cleaner element
	Faulty ground (-) connection	Clean and retighten*
	Weak or dead battery	Recharge or replace the battery*
	Engine malfunction	See an authorized Kohler service distributor/dealer
<b>Unit is difficult to start</b>	Stale or bad fuel	Replace the fuel
	Fuel vapor lock	See an authorized Kohler service distributor/dealer
	Faulty spark plug(s)	Replace and regap the spark plug(s)
	Inoperative ignition system	See an authorized Kohler service distributor/dealer
	Clogged air cleaner	Clean or replace the air cleaner element
<b>Engine starts but does not continue to run after start switch is released</b>	No generator output voltage	Check the AC voltage*
	No/low oil pressure	Check the oil. See an authorized Kohler service distributor/dealer
	Inoperative low oil pressure (LOP) safety shutdown switch	Replace the LOP shutdown switch*
	High temperature shutdown	Check for coolant level
	Inoperative high exhaust temp. (HET) and/or high water temp. (HWT) safety shutdown switch(es)	Replace the HET and/or HWT shutdown switch(es)*

\*If the procedures in this manual do not explain how to correct the problem, contact an authorized Kohler service distributor/dealer.

<b>Engine, continued</b>		
<b>Problem</b>	<b>Possible Cause</b>	<b>Corrective Action</b>
<b>Unit stops suddenly</b>	No fuel	Replenish the fuel
	Clogged air cleaner	Clean or replace the air cleaner element
	Fuse blown in controller	Replace the fuse
	Fuel line restriction	Check the fuel lines and tank*
	No/low oil pressure	See an authorized Kohler service distributor/dealer
	Inoperative low oil pressure (LOP) safety shutdown switch	Replace the LOP shutdown switch*
	High temperature shutdown	Check for coolant level
	Inoperative high exhaust temp. (HET) and/or high water temp. (HWT) safety shutdown switch(es)	Replace the HET and HWT shutdown switch(es)*
	Faulty spark plug(s)	Replace and regap the spark plug(s)
	Loss of AC output	See an authorized Kohler service distributor/dealer
<b>Unit operates erratically or lacks power</b>	Clogged air cleaner	Clean or replace the air cleaner element
	Stale or bad fuel	Replace the fuel
	Fuel pump vapor lock	Allow the unit to cool and attempt restart
	Faulty spark plug(s)	Replace and regap the spark plug(s)
	Inadequate cooling	Inspect the cooling system*
	Fuel line restriction	Check the fuel lines*
	Overloaded engine	Reduce the load*
<b>Engine overheats</b>	Inadequate cooling	Check the engine coolant level
	Inoperative thermostat	Replace the thermostat*
	Clogged air cleaner	Clean or replace the air cleaner element
	Overloaded engine	Reduce the load
	Inoperative temperature switch	Replace the shutdown switch*
<b>Low lube oil pressure</b>	Low lube oil level	Add lube oil
<b>Unit is noisy or emits an abnormal noise</b>	Exhaust system leak	Inspect the exhaust system for leaks and repair them*
	Exhaust system not securely installed	Check for loose parts and tighten them*
	Worn or inoperative bearing or gear	See an authorized Kohler service distributor/dealer
	Loose bolt or screw	Tighten the hardware
	Low lube oil level	Add lube oil

\*If the procedures in this manual do not explain how to correct the problem, contact an authorized Kohler service distributor/dealer.

<b>Electrical System</b>		
<b>Problem</b>	<b>Possible Cause</b>	<b>Corrective Action</b>
<b>Battery does not charge</b>	Loose or corroded connections	Clean and tighten the connections*
	Sulfated or worn-out battery	Check the electrolyte level and specific gravity (batteries with filler caps only)*
	Inoperative battery charging system	Check the charging system*
	Battery charging fuse blown	Replace the fuse. If the fuse blows again, see an authorized Kohler service distributor/dealer
<b>Starter failure</b>	Loose or corroded connections	Clean and tighten the loose connections*
	Low battery output	Check the electrolyte level and specific gravity (batteries with filler caps only). Check the battery voltage.*
	Inoperative starter solenoid	Replace the starter solenoid*
	Inoperative start/stop switch	Replace the switch*
	Inoperative wiring	Check the wiring*
<b>Starter cranks slowly</b>	Low battery output	Check the electrolyte level and specific gravity (batteries with filler caps only)*
	Too heavy viscosity lube oil	Use correct viscosity oil
	Loose or corroded wiring	Clean and tighten the loose connections*
	High starter current draw	Rebuild or replace the starter*

\*If the procedures in this manual do not explain how to correct the problem, contact an authorized Kohler service distributor/dealer.

<b>Generator</b>		
<b>Problem</b>	<b>Possible Cause</b>	<b>Corrective Action</b>
<b>No voltage output</b>	Circuit breaker in the OFF position	Reset the breaker to the ON position
	Circuit breaker tripped because of an overload on the generator set	Reduce the load. Reset the breaker to the ON position.
<b>Abnormal voltage output</b>	Generator malfunction	See an authorized Kohler service distributor/dealer

## Notes

## Section 5. Wiring Diagrams

### ⚠ WARNING

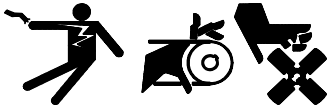

**Accidental starting.  
Can cause severe injury or death.**

Disconnect the battery cables before working on the generator set. Remove the negative (-) lead first when disconnecting the battery. Reconnect the negative (-) lead last when reconnecting the battery.

**Disabling the generator set. Accidental starting can cause severe injury or death.** Before working on the generator set or equipment connected to the set, disable the generator set as follows: (1) Disconnect the power to the battery charger, if equipped. (2) Remove the battery cables, negative (-) lead first. Reconnect the negative (-) lead last when reconnecting the battery. Follow these precautions to prevent the starting of the generator set by the remote start/stop switch.

### ⚠ WARNING

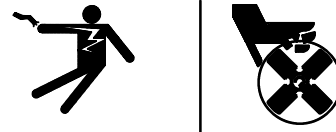

**Hazardous voltage. Moving rotor.  
Can cause severe injury or death.**

Operate the generator set only when all guards and electrical enclosures are in place.

**Grounding electrical equipment. Hazardous voltage can cause severe injury or death.** Electrocutation is possible whenever electricity is present. Open the main circuit breakers of all power sources before servicing the equipment. Configure the installation to electrically ground the generator set, transfer switch, and related equipment and electrical circuits to comply with applicable codes and standards. Never contact electrical leads or appliances when standing in water or on wet ground because these conditions increase the risk of electrocution.

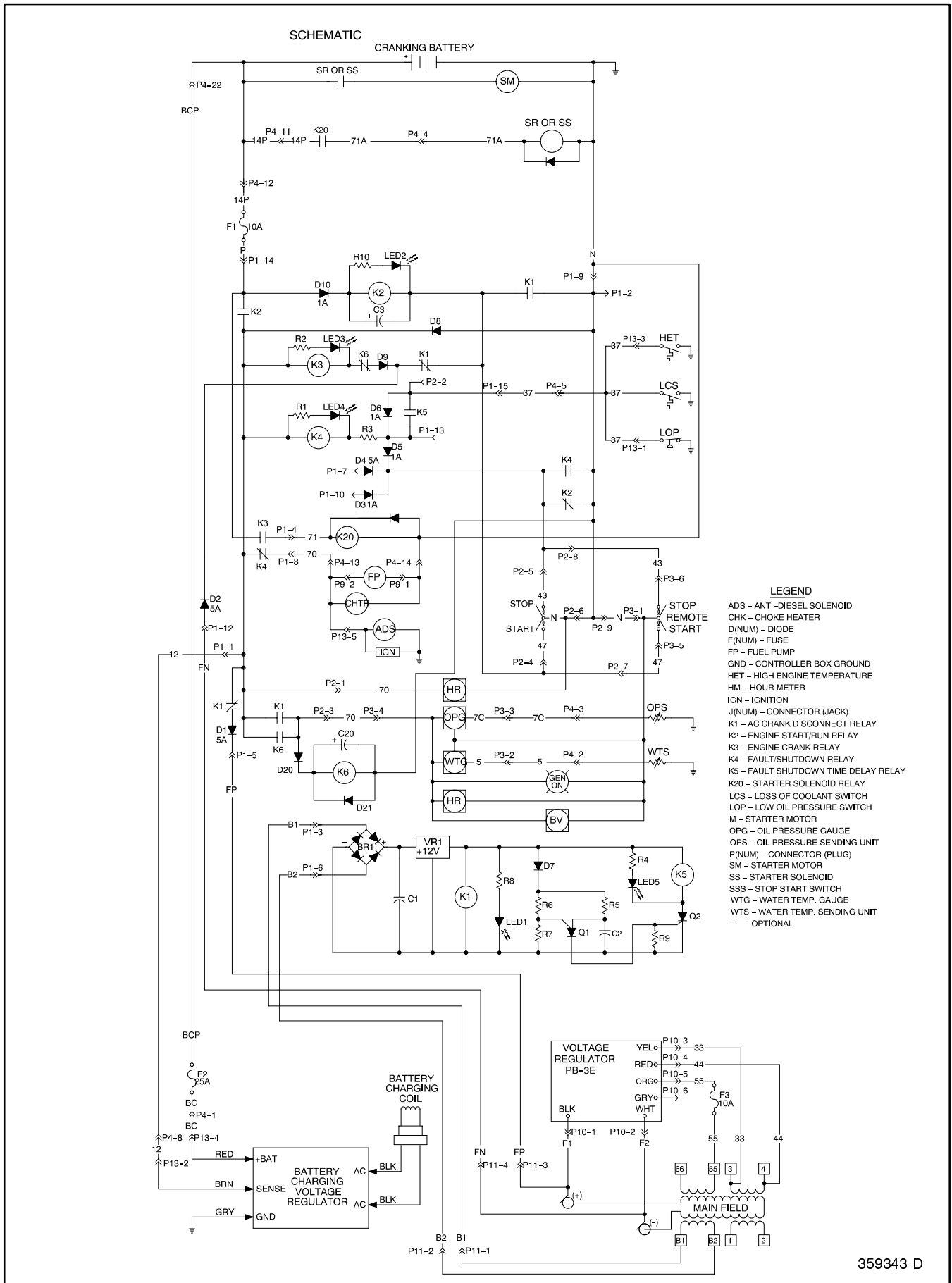

**Figure 5-1. Schematic Wiring Diagram**

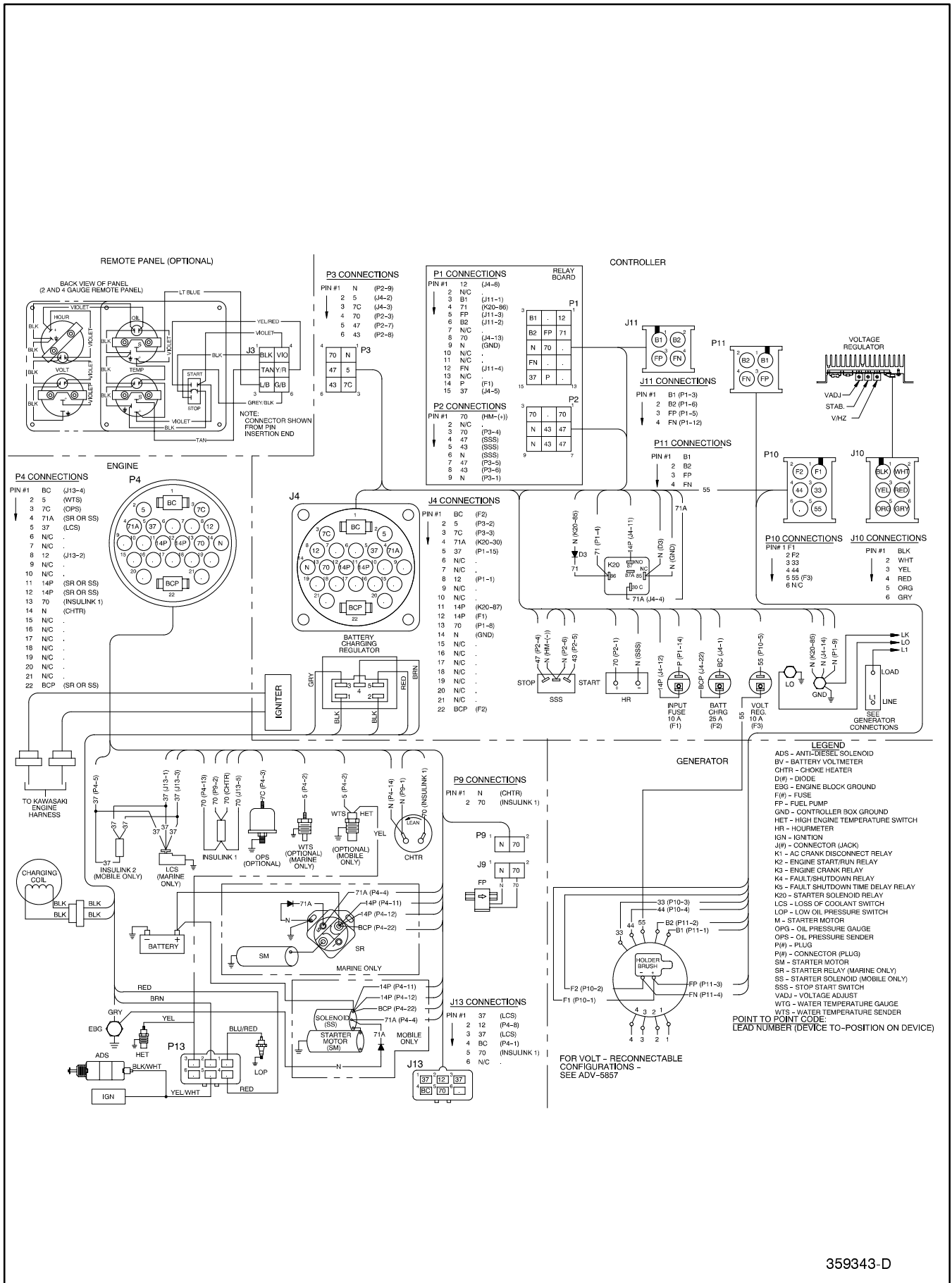

Figure 5-2. Point-to-Point Wiring Diagram

## Notes

# Appendix A. Glossary of Abbreviations

Abbreviations are used throughout this manual. Normally in the text they will appear in complete form with the abbreviation following in parenthesis the first time they are used. After that they will appear in the abbreviated form. The commonly used abbreviations are shown below.

AC	alternating current	gal./gals.	gallon, gallons	NBS	National Bureau of Standards
AISI	American Iron and Steel Institute	gph	gallons per hour	N.C.	normally closed
Amp	ampere	gpm	gallons per minute	NEC	National Electrical Code
Amps	amperes	gr.	grade	NEMA	National Electrical Manufacturers Association
ANSI	American National Standard Institute	grd.	ground	NFPA	National Fire Protection Association
API	American Petroleum Institute	HCHT	high cylinder head temperature	Nm	Newton meter, Newton meters
approx.	approximate, approximately	HET	high exhaust (or engine) temperature	no., nos	number, numbers
A/R	as required, as requested	Hg	mercury (element)	NPT	National Standard taper pipe thread per general use
A/S	as supplied, as stated, as suggested	H <sub>2</sub> O	water	N/R	not required
ASA	American Standards Association	HP	horsepower	OC	overcrank
ASME	American Society of Mechanical Engineers	hr, hrs	hour	OD	outside diameter
assy.	assembly	Hz	hertz (cycles per second)	OEM	original equipment manufacturer
ASTM	American Society for Testing Materials	ID	inside diameter	OS	overspeed, oversize
ATDC	after top dead center	IEEE	Institute of Electrical and Electronic Engineers	O/S	oversize
aux.	auxiliary	in.	inch(es)	OSHA	Occupational Safety and Health Act
AWG	American Wire Gauge	inc.	incorporated	OV	overvoltage
AWM	appliance wiring material	in. lbs.	inch pounds	oz.	ounce, ounces
BBDC	before bottom dead center	int.	internal	PF	power factor
BDC	before dead center	int.-ext.	internal-external	PMG	permanent magnet generator
BHP	brake horsepower	ISO	International Standards Organization	pot.	potentiometer
bmep	brake mean effective pressure	J	joule, joules	ppm	parts per million
Btu	British thermal unit	JIS	Japanese Industry Standard	psi	pounds per square inch
°C	Celsius degree	kg	kilogram, kilograms	pt., pts.	pint, pints
cc	cubic centimeter	kg/cm <sup>2</sup>	kilograms per square centimeter	PVC	polyvinyl chloride
CCA	cold cranking Amps.	kgm	kilogram meter(s)	qt., qts.	quart, quarts
CEC	Canadian Electrical Code	kJ	kilojoules (btu cal)	qty.	quantity
cfh	cubic feet per hour	km	kilometer, kilometers	ref.	reference
cfm	cubic feet per minute	kPa	kiloPascal, kiloPascals	RFI	radio frequency interference
CID	cubic inch displacement	kph	kilometers per hour	r.h.m.	round-head machine (screw)
cm	centimeter, centimeters	kV	kilovolt	rms	root mean square
cmm	cubic meters per minute	kVA	kilovolt amperes	RPM	revolutions per minute
co.	company	kW	kilowatt, kilowatts	RTV	room temperature vulcanization
cont'd.	continued	kWH	kilowatt hour	SAE	Society of Automotive Engineers
CSA	Canadian Standards Association	L	liter, liters	SCR	silicon-controlled rectifier
CT	current transformer	LxWxH	length x width x height	sec.	second, seconds
cu. in.	cubic inch, cubic inches	LED(s)	light emitting diode	spec.	specs, specification
cyl.	cylinder	lb., lbs.	pound, pounds	sq.	square
dB	decibel	L/hr.	liter per hour, liters per hour	sq. cm	square centimeters
dba	decibels (A weighted)	L/min.	liter(s) per minutes	sq. in.	square inch, square inches
DC	direct current	LOP	low oil pressure	tach	tachometer
DCR	direct current resistance	LP	liquefied petroleum	TDC	top dead center
deg.	degree	m	meter, meters	tech. pub.	technical publications
dept.	department	m <sup>3</sup>	cubic meter, cubic meters	temp.	temperature
dia.	diameter	max.	maximum	TIF	telephone influence factor
e.g.	example given	MCM	one thousand circular mils.	TP, TPs	technical publications
EIA	Electronic Industries Association	megger	megohmmeter	turbo	turbocharger
EMI	electromagnetic interference	MHz	megahertz	UHF	ultrahigh frequency
EPA	Environmental Protection Agency	mi.	mile, miles	UNC	Unified coarse thread (was NC)
etc.	et cetera (and so forth)	mil	one one-thousandth of an inch	UNF	Unified fine thread (was NF)
ext.	external	min.	minimum	UL	Underwriter's Laboratories, Inc.
°F	Fahrenheit degree	mJ	millijoule, millijoules	U/S	undersize
fl. oz.	fluid ounce, fluid ounces	MJ	mega joule, mega joules	U.S.A.	United States of America
FM	frequency modulation	mm	millimeter, millimeters	V	volt, volts
ft.	foot, feet	m <sup>3</sup> /min	cubic meters per minute	vac	volts alternating current
ft. lbs.	foot pound, foot pounds	MPa	megaPascal	vdc	volts direct current
ga.	gauge (meters, wire size)	mW	milliwatt, milliwatts	VHF	very high frequency
		MW	megawatt, megawatts	W	watt, watts
		N/A	not available or not applicable		

# Notes



# Notes



**TP-6033 5/99a**

© Kohler Co., 1999. All rights reserved.

# **KOHLER**<sup>®</sup> POWER SYSTEMS

KOHLER CO. Kohler, Wisconsin 53044  
Phone 920-565-3381, Web site [www.kohlergenerators.com](http://www.kohlergenerators.com)  
Fax 920-459-1646 (U.S.A. Sales), Fax 920-459-1614 (International)  
For the nearest sales and service outlet in U.S.A. and Canada  
Phone 1-800-544-2444