INSTALLATION INSTRUCTIONS

Relay Service Kits 324631, 324632, and 324633 For Replacing Relays 233180 and A-243997

Relays 233180 and A-243997 have been discontinued. Choose the replacement service kit from the table below and follow the respective installation procedure for that kit.

Discontinued Relay	Designation and Application	Replacement Relay Service Kit
A-243997	CC Relay	324631
A-243997	CR, 1CR, or 2CR	324632
233180	1CR or 3CR	324633

Examine the original 233180 or A-243997 relay to determine if it is designated a CC, CR, 1CR, 2CR, or 3CR relay. **Do NOT disconnect any leads without marking each lead.** Relay identification can be established by the following:

1. A CC, CR, 1CR, 2CR, or 3CR decal on the relay.
2. Refer to the wiring diagram. **NOTE:** Most wiring diagrams can be obtained from Kohler Generator Service Parts by indicating the model number and spec number found on the generator set nameplate.
3. If the relay is used as a CC relay, there will be a large 8- to 10-ga. lead (CC loop) running *through* the frame of the relay near the coil. See Figure 1. This lead is connected between the C relay and 2TS (thermal switch).

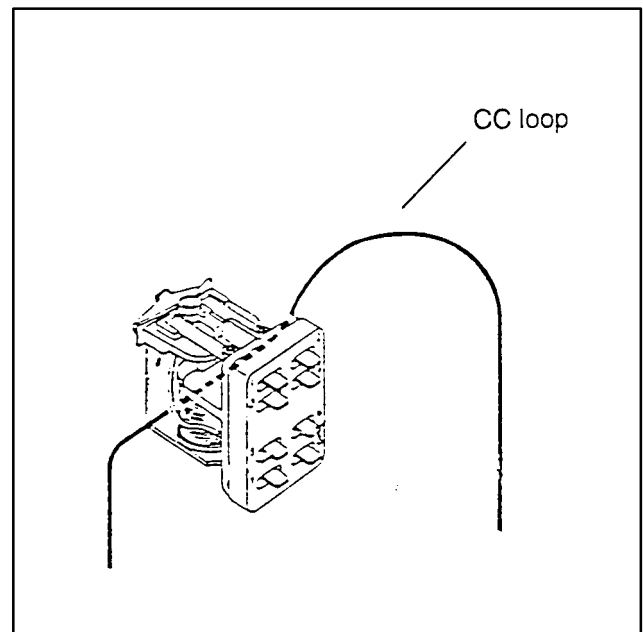

Figure 1. CC Relay with Lead



WARNING
Accidental starting.
Can cause severe injury or death.

Disconnect battery cables before working on generator set (negative lead first and reconnect it last).

INSTALLATION OF RELAY SERVICE KIT 324631 TO REPLACE RELAY A-243997 WHEN USED AS A CC RELAY

Read this entire procedure before attempting to install the service kit. Use the generator set wiring diagram during the installation procedure. Additional leads and/or terminals may be required in some applications.

NOTE

The relay was used in a wide variety of applications and this kit may not function properly in all controller applications. Contact an authorized service distributor if additional assistance is required to perform the replacement.

NOTE (Shunt Jumper, 10-15 kW Models)

If the original application of the relay uses a shunt jumper across the CC winding, see Figure 2. The replacement kit does NOT provide a diode suitable for the current draw. Contact an authorized service distributor for applications using the shunt jumper.

Following is a description of how the existing relay functioned in the circuit. The unique function of the CC (crank control) relay is to disconnect at the proper moment the crank circuit of exciter cranking models. During cranking, the magnetic flux around the loop of heavy wire placed next to the coil of the relay will cancel the flux of the coil and prevent movement of the relay armature. After the engine starts and exciter voltage exceeds the voltage of the series field, current will reverse direction through the loop allowing relay armature movement, resulting in de-energization of the cranking circuit. If the direction of the loop is incorrect the contacts of the CC relay will chatter.

This loop of wire represents a second winding of the relay coil and is illustrated with the  symbol in Figure 2. The main coil of relay CC is connected to S1. The CC relay also supplies a voltage sensing circuit to the RR relay (battery-charging regulator), and connects the exciter battery charging circuit.

The new relay functions differently. The CC relay coil loop is replaced by a diode. The diode allows exciter voltage to build up and prevents the exciter voltage from backfeeding the starting battery before the generator output energizes the new CC relay. The main CC relay coil is removed from the exciter circuit and is connected to the main AC output at L1/L2. On three-phase units connect the CC relay across L0/L1.

NOTE

A generator set wired for 277/480 vac will require a step-down transformer with a secondary output resulting in a 102-120 vac CC relay coil signal.

When sufficient AC output is achieved the CC relay is energized, and normally closed CC contacts open to de-energize the C relay. C contacts open to de-energize the crank circuit. See Figure 3. All other leads to relay contact terminals remain the same. If there is any question as to proper connection, refer to the appropriate wiring diagram.

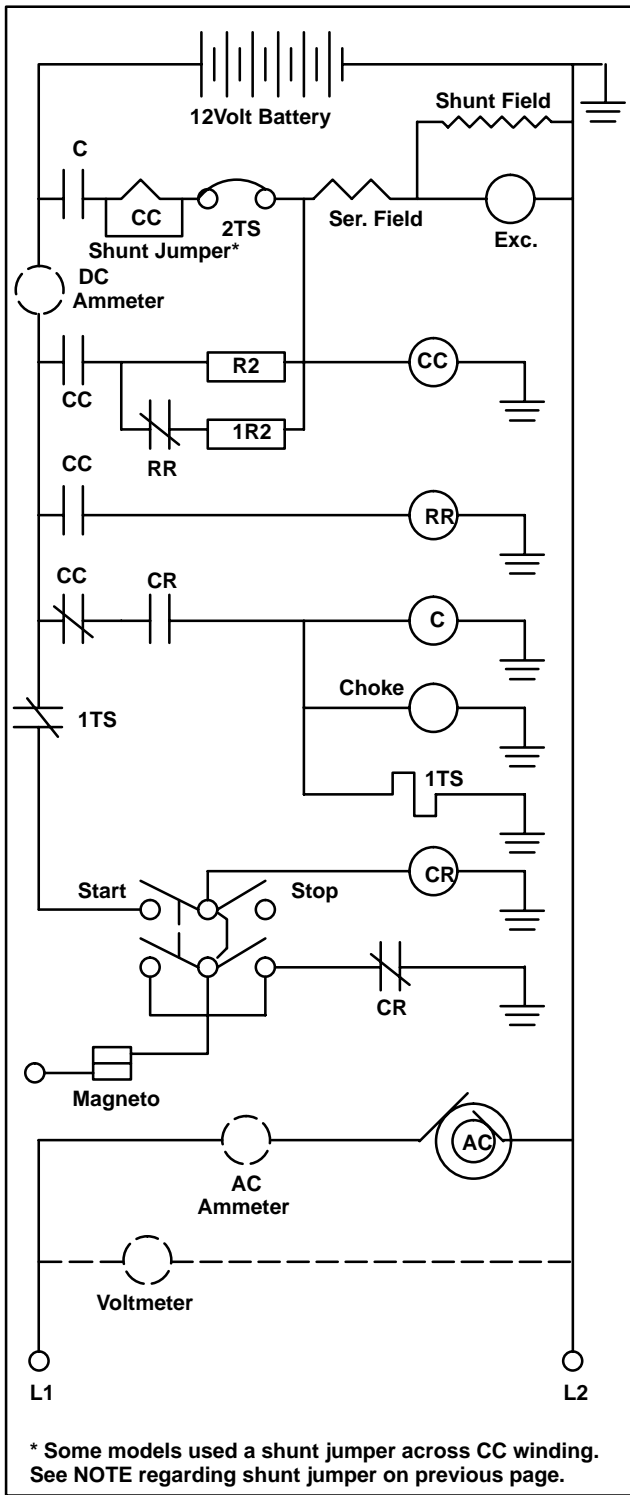

Figure 2. Existing Relay Connections (typical)

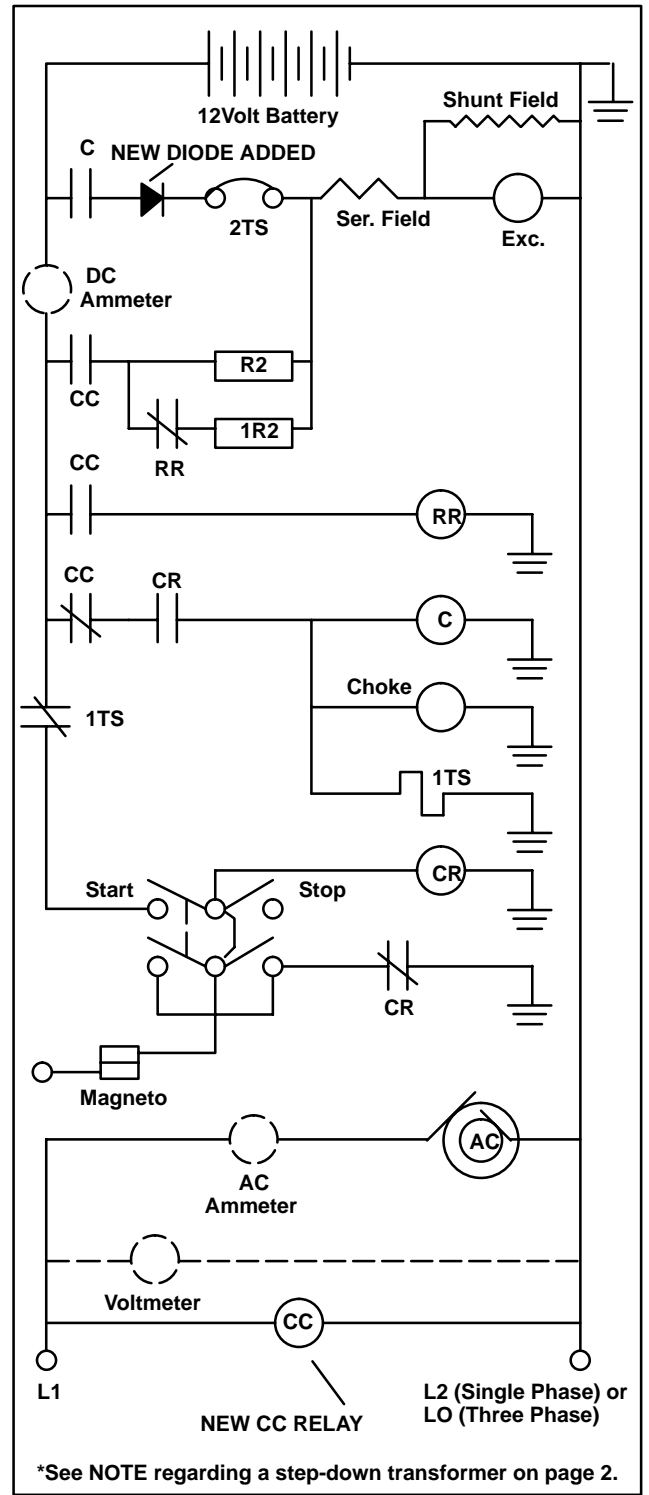

Figure 3. New Relay Connections (typical)

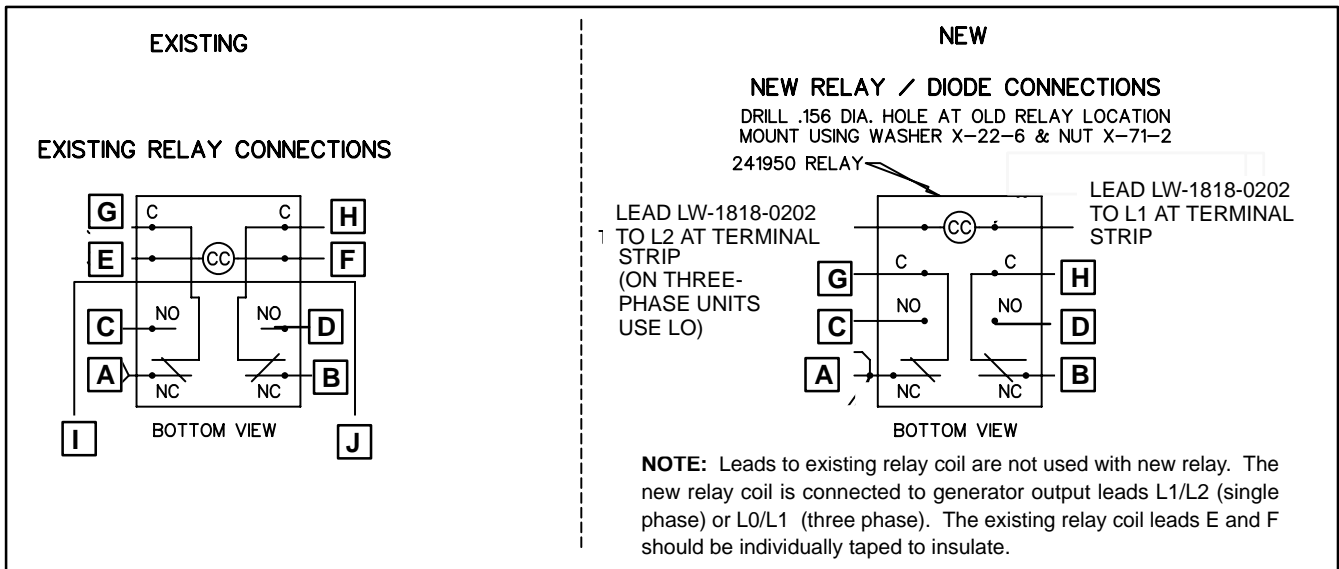

Figure 4. Wiring Diagram for CC Relay

1. Disconnect battery, negative lead first.
2. Remove controller cover or panel to access relay.
3. Examine existing CC relay and compare to the illustration in Figure 4. Identify the leads using the letters shown in Figure 4. Do this using masking tape or some other means to properly identify each lead.
4. Cut the lead (I, J) running through frame of relay at the midpoint. The diode will be connected in series with this lead.

Strip ends of 10-ga. leads. Connect insulink (X-367-7) and eyelet terminal (X-283-11) to each lead. Strip ends of lead which was running through frame of existing relay and connect to 10-ga. leads using insulinks.

Locate diode (222663) in a location to which 10-ga. leads will reach and drill two 0.25 in. (6 mm) dia. holes to mount diode. See Figure 4. Mount diode using two screws (X-50-3), lock washers (X-22-9), and nuts (X-70-2). Connect leads (I, J) to diode observing connection provided in Figure 5.

5. Disconnect leads of original CC relay. The leads (E, F) connected the original CC relay coil to the exciter circuit. These leads will not be reused. Individually tape to insulate each relay coil lead.
6. Remove original CC relay.
7. Drill one 0.156 in. (4 mm) dia. hole to mount new relay. See Figure 4 for drilling instructions. Location should be as near as possible to old relay location.

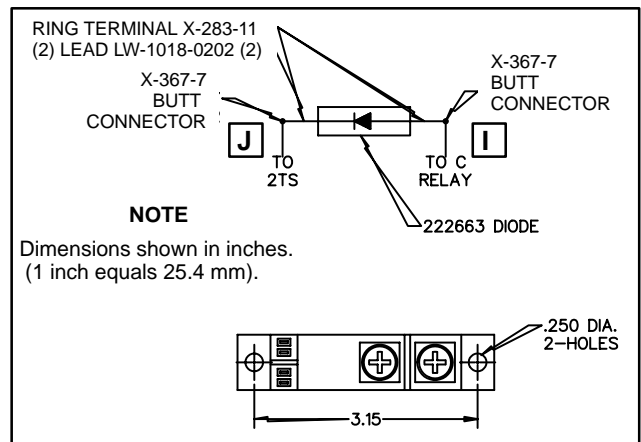

Figure 5. Diode Mounting Instructions

8. Mount new relay (241950) using lock washer (X-22-6) and nut (X-71-2).
9. Connect the new relay coil to the main AC output of the generator set.

Strip end of each 18-ga. lead and crimp 3/16 in. push-on terminal (X-431-24) onto one end. Connect these leads to relay coil terminals and to L1/L2 terminals at terminal strip in controller. On three-phase units connect the new CC relay across L0/L1. See Figures 3 and 4 as well as the appropriate wiring diagram.

NOTE

Some units may require terminals (not supplied) for connection of leads to L1/L2 (single phase) or L0/L1 (three phase).

10. Remove 1/4 in. push-on terminals from each remaining controller lead.

11. Strip end of leads and crimp on 3/16 in. push-on terminals (X-431-24) 18-22 ga. or (X-431-42) 14-16 ga. Select the size terminal for each lead. The kit is supplied with both size terminals. Some terminals may not be used.

NOTE

If leads are too short to connect to relay, additional leads should be added using the same gauge wire and an insulink (not supplied).

12. Connect remaining controller leads to relay using Figure 4 and appropriate wiring diagram.
13. Replace controller cover or panel.
14. Reconnect battery, negative lead last.

Parts List		
KIT 324631		
Qty.	Description	Part Number
2	Lead, 10 ga.	LW-1018-0202
2	Lead, 18 ga.	LW-1818-0202
1	Washer, #6 lock	X-22-6
2	Washer, lock	X-22-9
2	Terminal, #10 eyelet (ring)	X-283-11
2	Insulink	X-367-7
8	Terminal, 3/16 push-on 18-22 ga.	X-431-24
8	Terminal, 3/16 push-on 14-16 ga.	X-431-42
2	Screw, 10-24 x 3/4 in.	X-50-3
2	Nut, 10-24	X-70-2
1	Nut, 6-32	X-71-2
1	Diode	222663
1	Relay	241950

INSTALLATION OF RELAY SERVICE KIT 324632 TO REPLACE RELAY A-243997 WHEN NOT USED AS A CC RELAY

1. Disconnect battery, negative lead first.
2. Remove controller cover or panel to access relay.
3. Examine existing CR, 1CR, or 2CR relay and compare to the illustration in Figure 6. Identify the leads using the letters shown in Figure 6. Do this using masking tape or some other means to identify each lead.

Disconnect leads of existing CR, 1CR, or 2CR.

4. Remove 1/4 in. push-on terminals from each lead.
5. Strip end of leads and crimp on 3/16 in. push-on terminals (X-431-24) 18-22 ga. or (X-431-42) 14-16 ga. Select the proper size terminal for each lead. The kit is supplied with both size terminals. Some terminals may not be used.
6. Remove existing CR, 1CR, or 2CR relay.
7. Drill two 0.187 in. (5 mm) dia. holes 2.5 in. (63.5 mm) apart to mount new relay. See Figure 7 for drilling instructions. Location should be as near as possible to old relay location.
8. Mount new relay (248363) using two screws (X-51-15), lock washers (X-22-7), and nuts (X-72-4).

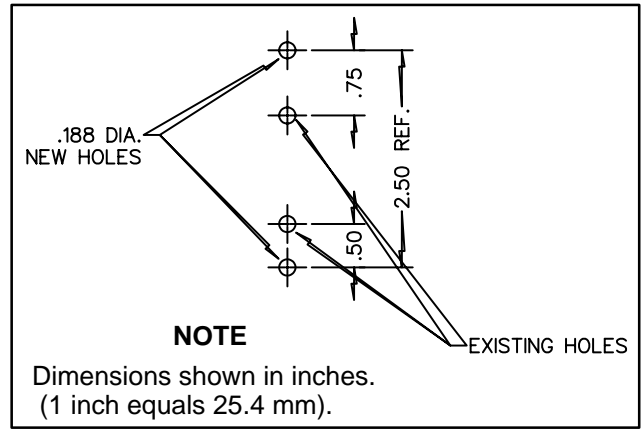

Figure 7. Relay Drilling Instructions

NOTE

If leads are too short to properly connect to relay, additional leads should be added using the same gauge wire and an insulink (not supplied).

9. Connect controller leads to relay using wiring diagram found in Figure 6.
10. Replace controller cover or panel.
11. Reconnect battery, negative lead last.

Parts List

KIT 324632		
Qty.	Description	Part Number
2	Washer, #8 lock	X-22-7
8	Terminal, 3/16 push-on 18-22 ga.	X-431-24
8	Terminal, 3/16 push-on 14-16 ga.	X-431-42
2	Screw, 8-32 x 1/2	X-51-15
2	Nut, 8-32	X-72-4
1	Relay	248363

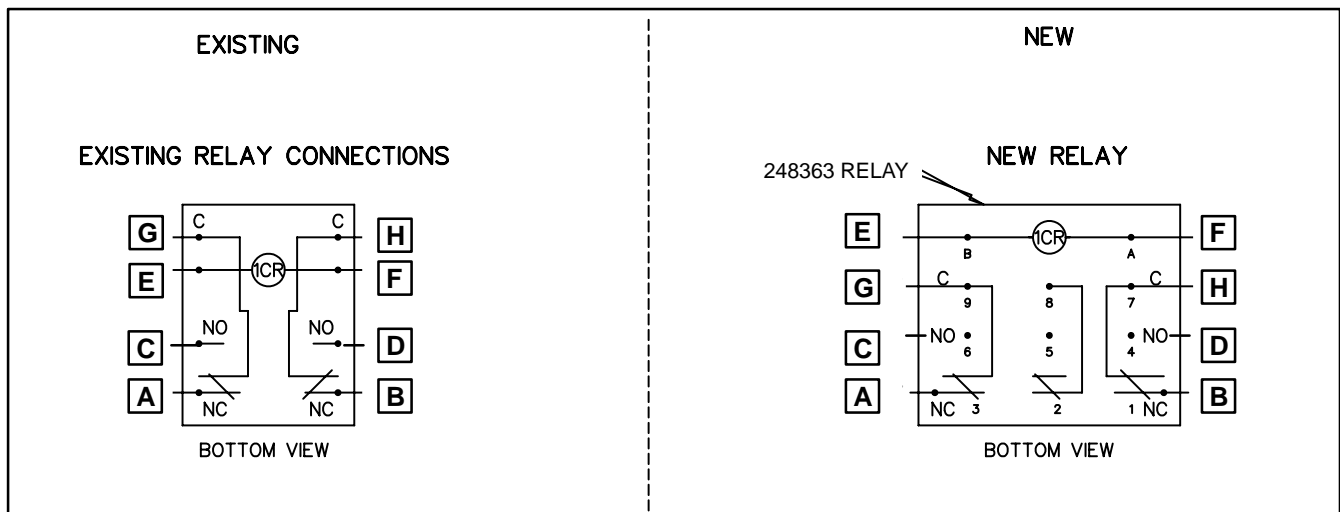

Figure 6. Wiring Diagram for CR, 1CR, and 2CR Relay

INSTALLATION OF 324633 KIT TO REPLACE RELAY 233180

1. Disconnect battery, negative lead first.
2. Remove controller cover or panel to access relay.
3. Examine existing 1CR or 3CR relay and compare to the illustration in Figure 8. Identify the leads using the letters shown in Figure 8. Do this using masking tape or some other means to identify each lead.

Disconnect leads of existing 1CR or 3CR.

4. Remove 1/4 in. push-on terminals from each lead.
5. The kit is supplied with both size terminals. Select the proper size terminal for each lead. Strip end of leads and crimp on 3/16 in. push-on terminals (X-431-24) 18-22 ga. or (X-431-42) 14-16 ga. Some terminals may not be used.
6. Remove existing 1CR or 3CR relay.
7. Drill two 0.187 in. (5 mm) dia. holes 2.5 in. (63.5 mm) apart to mount new relay. See Figure 7 for drilling instructions. Location should be as near as possible to old relay location.

8. Mount new relay (226664) using two screws (X-51-15), lock washers (X-22-7), and nuts (X-72-4).

NOTE

If leads are too short to properly connect to relay, additional leads should be added using the same gauge wire and an insulink (not supplied).

9. Connect controller leads to relay using wiring diagram found in Figure 8.
10. Replace controller cover or panel.
11. Reconnect battery, negative lead last.

Parts List

KIT 324633		
Qty.	Description	Part Number
2	Washer, #8 lock	X-22-7
8	Terminal, 3/16 push-on 18-22 ga.	X-431-24
8	Terminal, 3/16 push-on 14-16 ga.	X-431-42
2	Screw, 8-32 x 1/2	X-51-15
2	Nut, 8-32	X-72-4
1	Relay	226664

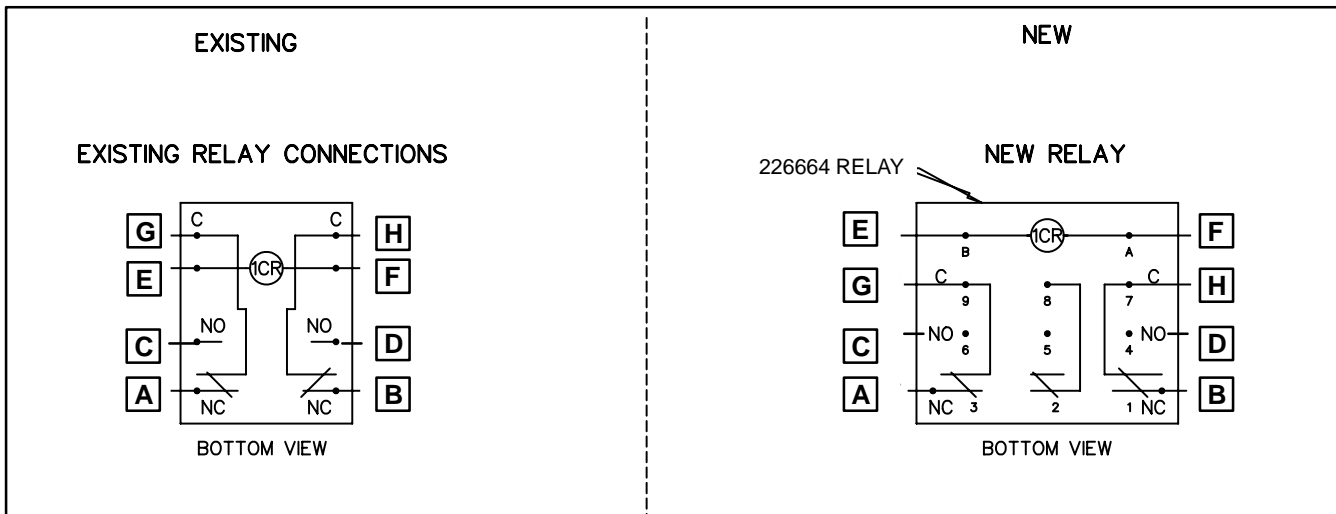

Figure 8. Wiring Diagram for 1CR and 2CR Relay