

INSTALLATION INSTRUCTIONS

Original Issue Date: **7/95**

Model: **Gasoline- and Diesel-Powered Marine, and Diesel-Powered RV/Mobile Generator Sets**

Market: **Marine, RV/Mobile**

Subject: **Remote Start Two-Meter Panel Kits PA-344040 (12 Volt) and PA-344842 (24 Volt)**

Installation of this kit allows starting/stopping from a location remote of the generator set. The engine oil pressure gauge and water temperature gauge illuminate. The generator set controller back panel comes equipped with a 6-pin connector for connection of the kit. See Figure 1 for panel features.

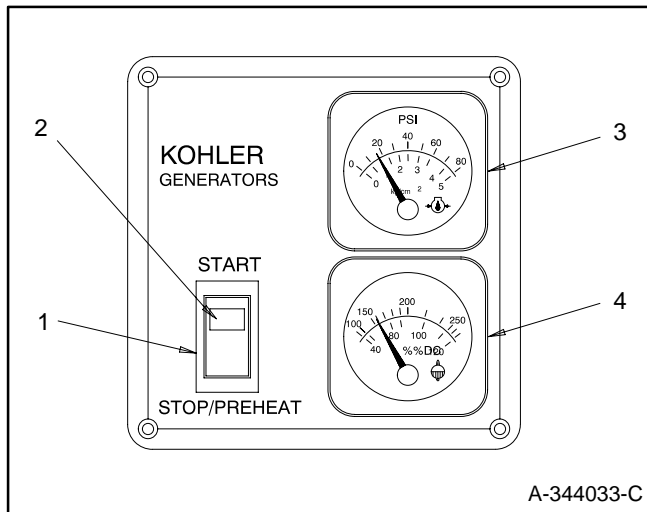

- 1. Start/stop switch
- 2. On light
- 3. Engine oil pressure
- 4. Water temperature

Figure 1. Panel Features

Marine Generator Sets. All models shipped after June 1992 require the addition of a sender kit to allow the oil pressure and water temperature gauges to function. Contact an authorized Kohler distributor/dealer for part number of sender kit. Earlier models may have senders already installed. Follow lead 5 to water temperature sender and lead 7C to oil pressure sender to determine presence of senders.

NOTE

This kit may require remote connection/extension harnesses PA-249334 15 ft. (4.6 m) or PA-249336 25 ft. (7.6 m). Do not exceed 75 ft. (22.9 m) extension.

Start/Stop Switch (Marine), Start/Stop-Preheat Switch (RV). Rocker-type switch with On light used to start and stop generator set.

NOTE

RV Generator Sets. During cold weather starts: 7/10CCO (below 50°F [10°C]), 15/20CCO (below 23°F [-5°C]), place controller start switch in Stop-Preheat position for 15-20 seconds before attempting to start generator set. Doing so energizes the *glow plugs* on the 7/10CCO units or the *air-heater coil* on the 15/20CCO units.

NOTE

Do not place Start/Stop-Preheat Switch in Stop-Preheat position for more than 30 seconds or damage may occur to preheat feature.

Engine Oil Pressure Gauge measures engine oil pressure.

NOTE

During engine break-in period, the engine sometimes produces high oil pressure readings. Consult your Operator's Manual for specific values.

Water Temperature Gauge measures engine coolant temperature.

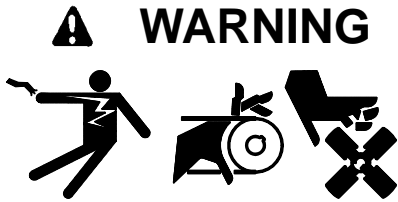

WARNING

Accidental starting. Can cause severe injury or death.

Disconnect battery cables before working on generator set (disconnect negative lead first and reconnect it last).

Disabling generator set. Accidental starting can cause severe injury or death. Disconnect battery cables (remove negative lead first and reconnect it last) to disable generator set before working on the generator set or connected equipment. The generator set can be started by the remote start/stop switch unless this precaution is followed.

WARNING

Explosion.
Gasoline vapors can cause explosion and severe injury or death.

Before starting generator set, operate blower 4 minutes and check engine compartment for gasoline vapors.

Ignition protected equipment. Explosive fuel vapors can cause severe injury or death. Gasoline vapors can cause an explosion. USCG Regulation 33CFR183 requires all electrical devices (ship-to-shore transfer switch, remote start panel, etc.) to be ignition protected when used in a gasoline (gaseous)-fueled environment. The electrical devices listed above are not ignition protected and are not certified to operate in a gasoline (gaseous)-fueled environment such as engine room or near fuel tanks. Acceptable locations are wheelhouse or other living areas sheltered from rain and water splash.

Installation

1. Place the generator start/stop switch in the stop position.
2. Disconnect the generator set engine starting battery, negative (-) lead first.
3. Determine where in the vehicle/wheelhouse or bridge to mount the panel. The length of the wiring harness and the size of the panel (including mounting depth), limits this decision. See Figure 2 for dimensions. Allow a minimum of 2 3/4 in. (70 mm) mounting clearance behind the panel. See Figure 4 for the panel assembly wiring.

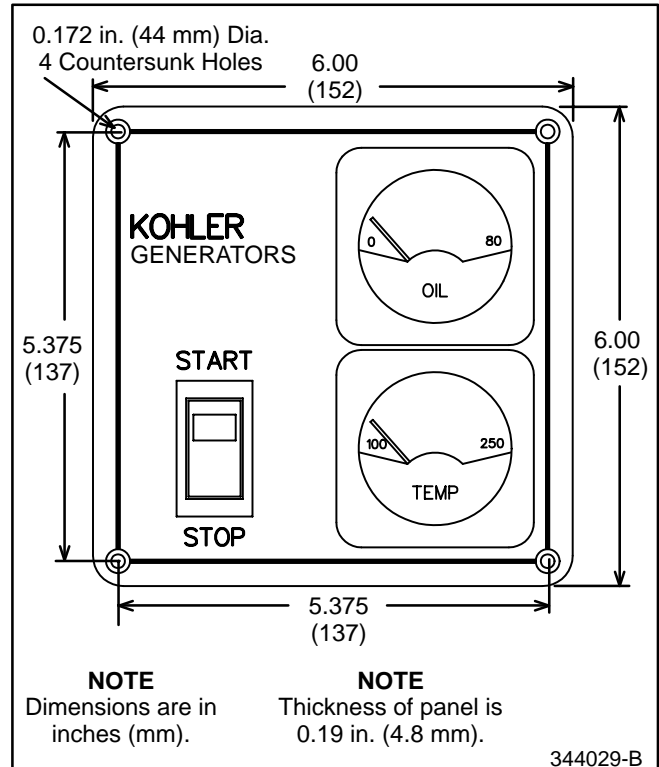

Figure 2. Meter Panel Dimensions

NOTE

If needed, order an additional remote extension harness kit. Do not exceed 75 ft. (22.9 m) with remote extension harness kits.

Remote Extension Harness Kit Part Numbers

Length	Marine/Mobile 3-phase Kit	RV 1-phase Kit
15 ft. (4.6 m)	PA-249334	PA-225580
25 ft. (7.6 m)	PA-249336	PA-225581

4. Connect remote extension harness to remote panel and mount panel using four screws (not supplied). See Figure 5.
5. Connect the other end of extension harness or remote extension harness to back of generator set controller. See Figure 5.

Marine installations only. For 4/6.5CZ and 3.5/5CFZ models only, use supplied wire strap to secure wiring harness to controller. Use screw to attach wire strap to hole in controller near 6-pin connector. Discard wire strap and screw for all other models. Use rubber grommets and cable ties to protect and secure wiring harness. Install in accordance with USCG Regulations 183.425 through 183.460.

6. **Gasoline models only.** Apply warning decal to a clean, dry surface in a visible location as near as practical to remote start panel.
7. Reconnect generator starting battery, negative (-) lead last.
8. Start/stop generator set using controller switch and remote switch. Monitor gauges for correct function.
9. Stop generator set.

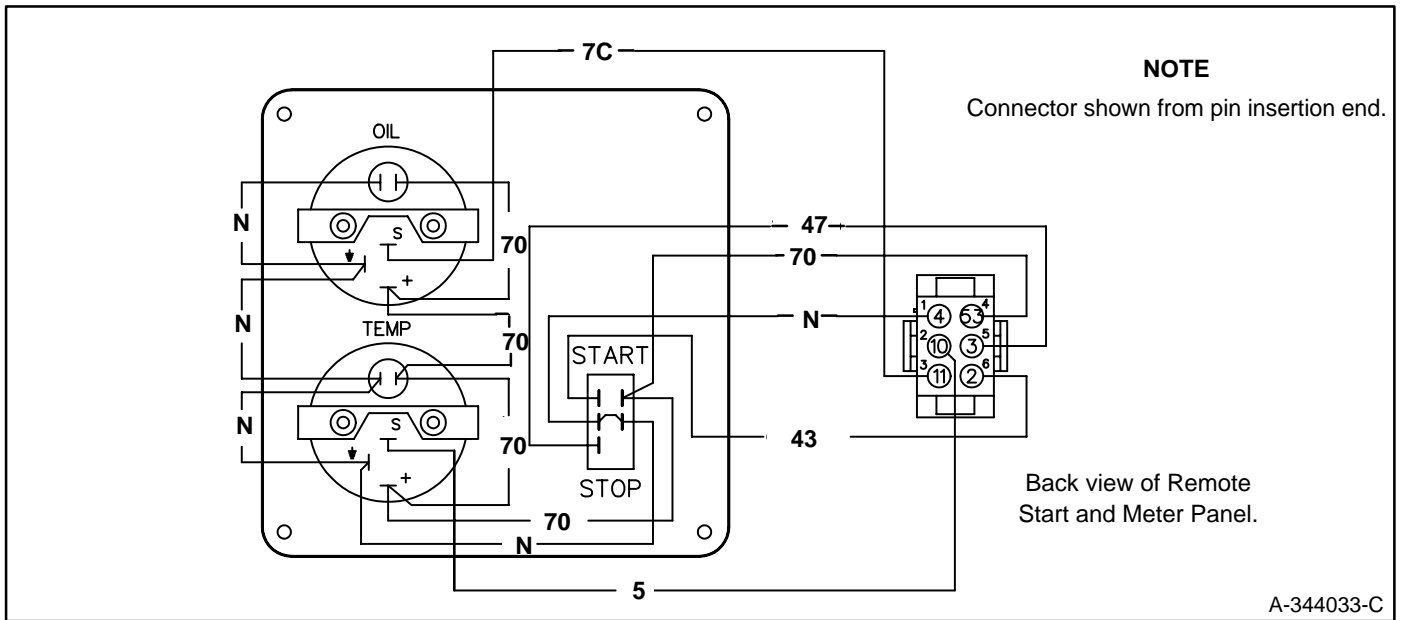

Figure 3. Typical Electrical Connections

Remote Start Two-Meter Panel Kits

Parts List				
Kits: PA-344040 and PA-344842				
Qty.	Description	Common Parts	PA-344040	PA-344842
1	Panel, remote start and meter		A-344033	A-344840
1	Gauge, water temperature	344035		
1	Gauge, oil pressure	344036		
1	Harness, panel wiring	344031		
1	Panel, cutout	344029		
1	Switch, rocker		344039	344839
1	Decal, warning	249494		

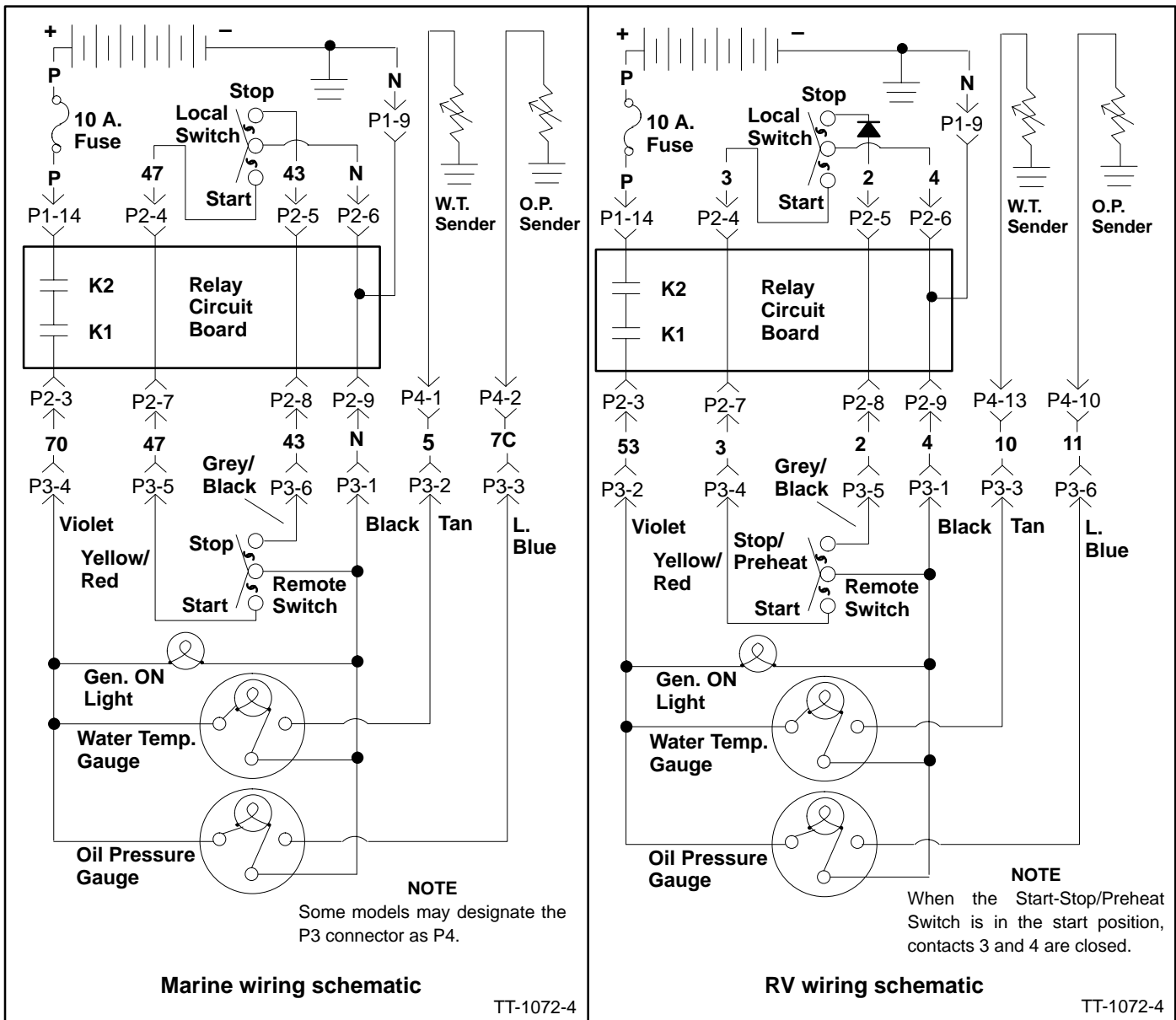

Figure 4. Typical Electrical Connections

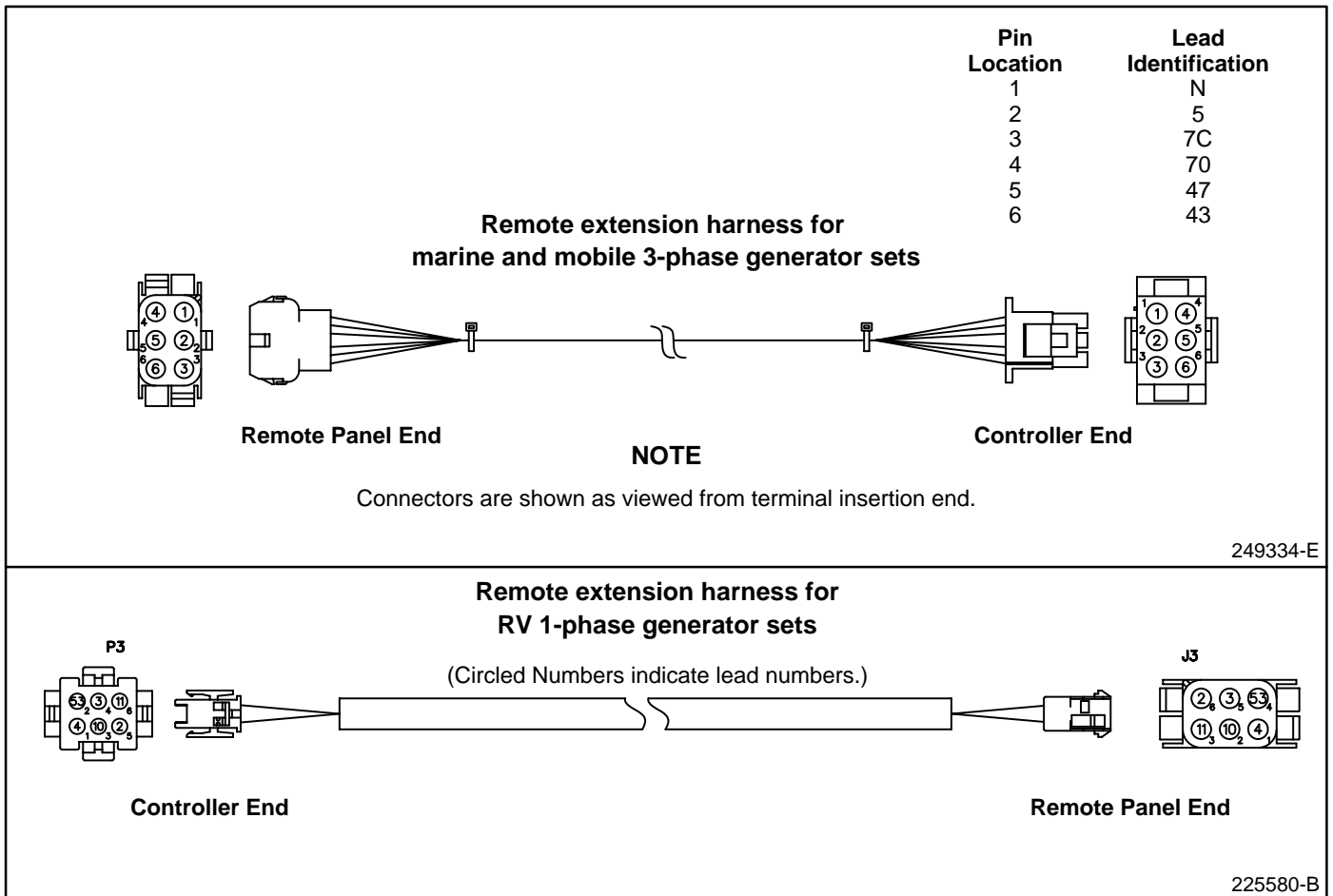

Figure 5. Remote Extension Harness