INSTALLATION INSTRUCTIONS

Original Issue Date: **7/95**
 Model: **4.5CKM**
 Market: **RV**
 Subject: **Exhaust Kit 277790**
(Generator Mounted Above Floor—Straight Exhaust)

Use this exhaust kit on generator sets mounted above the RV floor. This kit contains a right-side muffler outlet (as viewed from the unit's service side).

This kit does not contain a tail pipe since tail pipe length varies with most installations. Install the tail pipe to direct the exhaust gases beyond the perimeter of the vehicle. Use a tail pipe with a gradual bend (not 90°) to avoid excessive back pressure. Direct the tail pipe away from the normal air stream. Position tail pipe end so that discharged exhaust gases may not be drawn into the vehicle interior through windows, doors, air conditioners, etc.

California Proposition 65

⚠ WARNING

Engine exhaust from this product contains chemicals known to the State of California to cause cancer, birth defects, or other reproductive harm.



Accidental starting.
Can cause severe injury or death.

Disconnect battery cables before working on generator set (negative lead first and reconnect it last).

Accidental starting can cause severe injury or death. Turn generator set master switch to OFF position, disconnect power to battery charger, and remove battery cables (remove negative lead first and reconnect it last) to disable generator set before working on any equipment connected to generator set. The generator set can be started by automatic transfer switch or remote start/stop switch unless these precautions are followed.

⚠ WARNING
<p>Carbon monoxide. Can cause severe nausea, fainting, or death.</p> <p>The exhaust system must be leakproof and routinely inspected.</p>

Carbon monoxide can cause severe nausea, fainting, or death. Never operate the generator set inside a building unless the exhaust gas is piped safely outside. Never operate in any area where exhaust gas could accumulate and seep back inside an occupied building or vehicle. Be careful when parking your vehicle to avoid obstructing the exhaust outlet. The exhaust gases must discharge freely to prevent carbon monoxide from deflecting into the vehicle. Avoid breathing exhaust fumes when working on or near the generator set. Carbon monoxide is particularly dangerous because it is an odorless, colorless, tasteless, nonirritating gas that can cause death if inhaled for even a short period of time.

Carbon monoxide can cause severe nausea, fainting, or death. Carbon monoxide is a poisonous gas which is present in exhaust gases. Carbon monoxide poisoning symptoms include but are not limited to the following:

- Light-headedness, dizziness
- Physical fatigue, weakness in joints and muscles
- Sleepiness, mental fatigue, inability to concentrate or speak clearly, blurred vision
- Stomachache, vomiting, nausea

If any of these symptoms is experienced and carbon monoxide poisoning is possible, affected persons should seek fresh air immediately. They should remain active. They should not be permitted to sit, lie down, or fall asleep. Alert others to the situation. If the condition of affected persons does not improve within minutes of breathing fresh air, they should seek medical attention.

Carbon monoxide can cause severe nausea, fainting, or death. Install exhaust system tail pipe so discharged exhaust gases will not be drawn into vehicle interior through windows, doors, air conditioners, etc. Do not use flexible tail piping since this type could crack and allow lethal exhaust fumes to enter the vehicle.

Carbon monoxide can cause severe nausea, fainting, or death. In addition to routine inspection of the exhaust system, install a carbon monoxide detector. Consult your coach builder or dealer for installation of approved detectors. Inspect your detector before each generator set use.

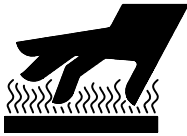
 WARNING

<p>Hot engine and exhaust system. Can cause severe injury or death.</p> <p>Do not work on generator set until it is allowed to cool.</p>

Hot parts can cause severe injury or death. Do not touch hot engine parts. An engine gets hot while running and exhaust system components get extremely hot.

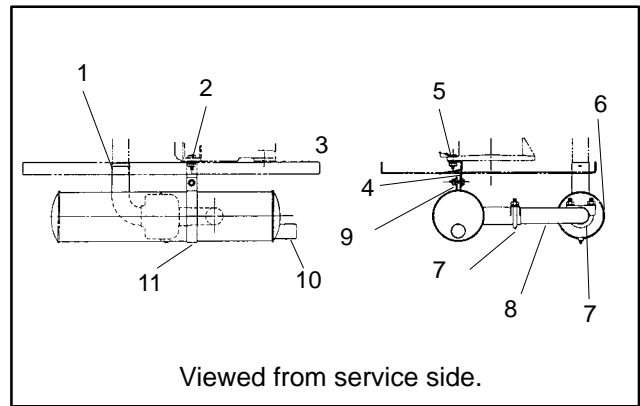
Fire can cause severe injury or death. Hot exhaust system can ignite adjacent combustible materials. Do not locate electrical wiring, fuel lines, or combustible material above the exhaust muffler. Exercise caution when parking your vehicle to prevent grass fires started by exhaust system and hot exhaust gases.



1. Pin, Cotter (X-37-6). Assemble to spark arrestor as shown.
2. Use front mounting hole on crankcase to mount muffler bracket.
3. Engine End
4. Bracket (277791)
5. Screw, H.C. 3/8-16 x 1 1/4 (X-6238-4), Washer 3/8 (X-25-37), Nut, 3/8-16 (X-6210-9)
6. Arrestor, Spark (277795)
7. Clamp, Muffler (237548)
8. Elbow, Exhaust (238389)
9. Screw, H.C. 5/16-18 x 1 1/4 (X-125-24), Washer 5/16 (X-25-85), Nut, 5/16-18 (X-6210-7)
10. Muffler (238391)
11. Strap, Muffler Mounting (277725)

Figure 1. Muffler Mounting—Right-Side Outlet (Straight Exhaust)

Parts List		
Kit 277790		
Qty.	Description	Part Number
1	Screw, H.C. 5/16-18 x 1 1/4	X-125-24
1	Washer, 5/16	X-25-85
1	Washer, 3/8	X-25-37
1	Pin, cotter 1/8 x 2	X-37-6
1	Screw, H.C. 3/8-16 x 1 1/4	X-6238-4
1	Nut, 5/16-18	X-6210-7
1	Nut, 3/8-16	X-6210-9
2	Clamp, muffler	237548
1	Muffler	238391
1	Strap, muffler mounting	277725
1	Bracket	277791
1	Arrestor, spark	277795
1	Elbow, exhaust	238389