INSTALLATION INSTRUCTIONS

Original Issue Date: 11/96
 Model: 20CCO
 Market: RV
 Subject: **PBIII Voltage Regulator Relocation Kit (227987)**

This kit relocates the voltage regulator from the junction box to the generator skid. Observe the following safety precautions when installing this kit. Refer to the Parts List and Figure 1 for parts identification and location.



Accidental starting.
Can cause severe injury or death.

Disconnect battery cables before working on generator set (disconnect negative lead first and reconnect it last).

Disabling generator set. Accidental starting can cause severe injury or death. Disconnect battery cables (remove negative lead first and reconnect it last) to disable generator set before working on the generator set or connected equipment. The generator set can be started by the remote start/stop switch unless this precaution is followed.

WARNING	
 Hazardous voltage.	 Moving rotor.
Can cause severe injury or death.	
Operate generator set only with all guards and electrical enclosures in place.	

Short circuits. Hazardous voltage can cause severe injury or death. Short circuits can cause bodily injury and/or equipment damage. Do not contact electrical connections with tools or jewelry while adjustments are made. Remove wristwatch, rings, and jewelry before servicing equipment.

Installation

1. Place the generator start/stop switch in the stop position.
2. Disconnect the generator set engine starting battery, negative (-) lead first.
3. Disconnect the 6-pin connector (P10/J10) at the voltage regulator. See Figure 2.
4. Remove mounting hardware securing the voltage regulator to the junction box.
5. Remove and discard the voltage regulator.
6. Drill four 0.109-in. (7/64-in.) diameter holes for regulator mounting in location shown in Figure 1. Use regulator as a template.
7. Mount the regulator (E-278598), with adjusting pots as shown, using four screws (X-794-2).
8. Connect wiring harness (227988) to the voltage regulator and main engine harness. Use tie wraps as necessary to secure harness to generator set.
9. Reconnect generator starting battery, negative (-) lead last.
10. Start the generator set and verify that the set performs properly. Stop generator set.

Regulator Relocation Kit

Parts List		
Kit: 227987		
Qty.	Description	Part Number
1	Regulator, voltage PBIIE	E-278598
1	Harness, wiring (3.5 ft.)	227988
4	Screw, drill	X-794-2

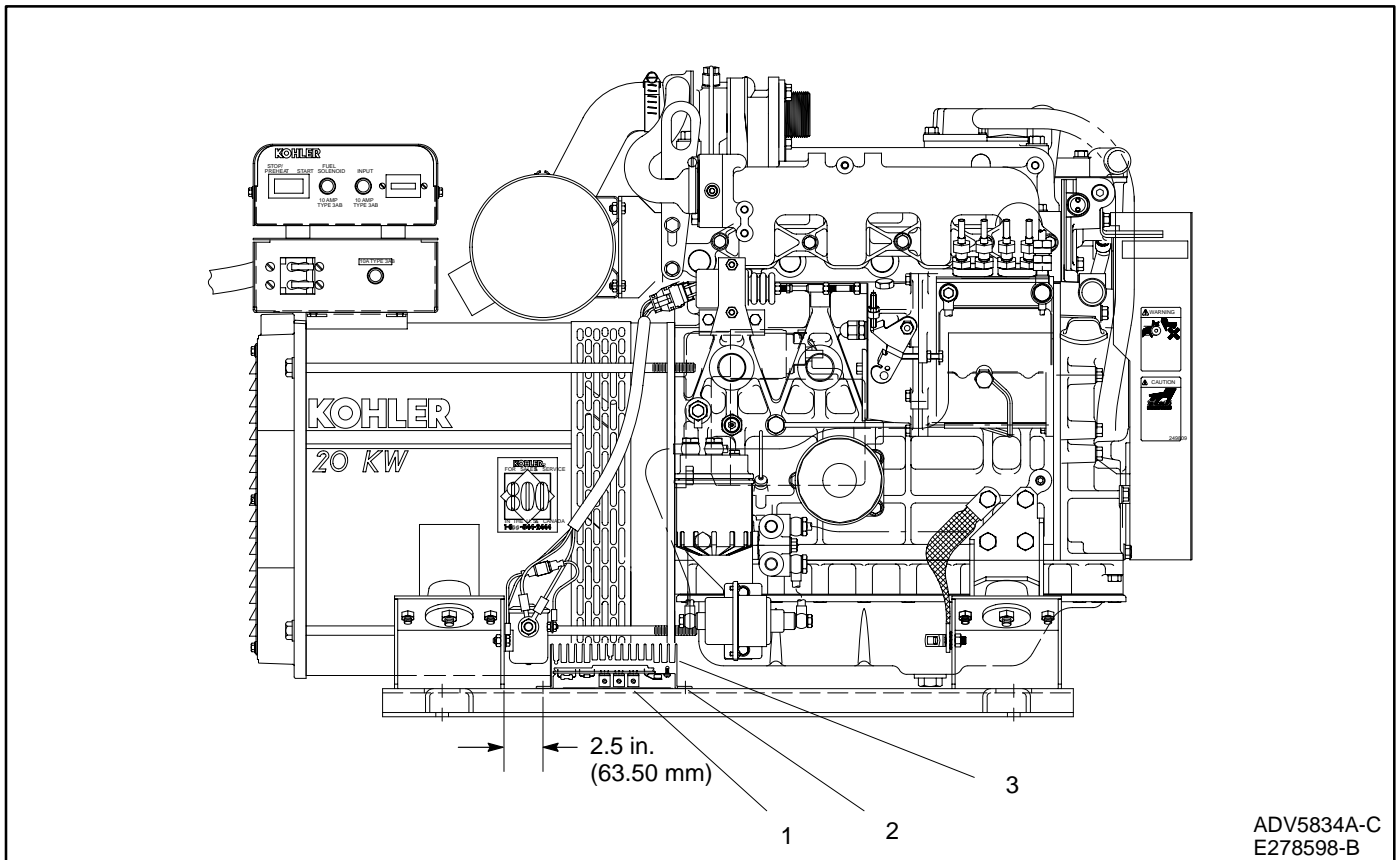

1. Adjusting pots
2. Screws (X-794-2)

3. Voltage regulator (E-278598)

ADV5834A-C
E278598-B

Figure 1. Voltage Regulator Mounting Installation

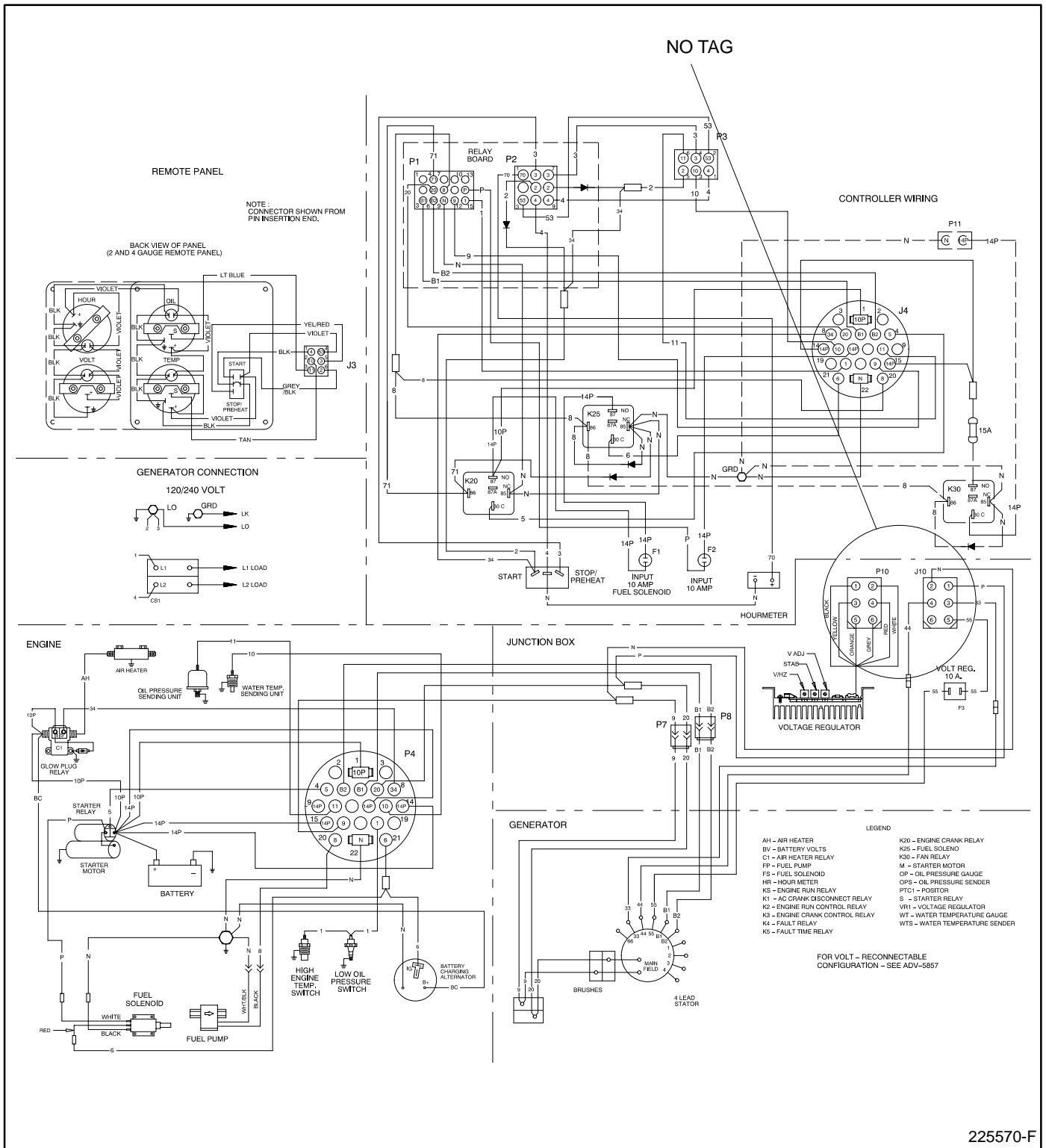

1. Voltage regulator 6-pin connector (P10/J10)

Figure 2. Wiring Diagram