



## INSTALLATION INSTRUCTIONS

### Oil Drain Kit PA-254991 10/12 CC/CZ Ford Mobile Generator Sets

This kit allows draining of the engine oil when placement of a drain pan beneath the engine is not possible or desirable. A manual drain valve is installed in place of the oil drain plug. A flexible hose attached to the valve allows draining the engine oil from the service side of the generator set.



**WARNING**

**Accidental starting.**  
**Can cause severe injury or death.**

Disconnect battery cables before working on generator set (negative lead first and reconnect it last).

**Accidental starting can cause severe injury or death.** Disconnect battery cables (remove negative lead first and reconnect it last) to disable generator set before working on any equipment connected to generator. The generator set can be started by remote start/stop switch unless this precaution is followed.

<b>WARNING</b>
<p><b>Hot engine and exhaust system.</b> <b>Can cause severe injury or death.</b></p> <p>Do not work on generator set until unit is allowed to cool.</p>

**Hot parts can cause severe injury or death.** Do not touch hot engine parts. An engine gets hot while running and exhaust system components get extremely hot.

### INSTALLATION

1. Disconnect battery, negative lead first.
2. While engine is warm, remove oil drain plug and drain engine oil into a suitable container.
3. Install oil drain valve (249437) in place of oil drain plug. Connect hose (X-651-3) to drain valve with hose clamp (X-426-9). See Figure 1.
4. Drill a 0.188 in. (4.7 mm) diameter hole in mounting bracket as shown in Figure 1. Install hose clip (267959) on mounting bracket with screw (X-51-15), washer (X-25-48) and nut (X-6210-4). Secure hose in hose clip.
5. Ensure that oil drain valve is closed. Fill engine with proper grade oil for expected temperature range (see generator operator's manual TP-5405).
6. Reconnect battery cables, negative lead last. Run generator and check for leaks.
7. Wipe up any spilled oil with rags. Dispose of rags in a proper container.

Parts List		
Qty.	Description	Part Number
1	Washer, plain, #8, 0.188 x 0.439 x 0.049	X-25-48
1	Clamp, hose	X-426-9
1	Screw, 8-32 x 0.50	X-51-15
1	Nut, 8-32	X-6210-4
1	Hose	X-651-3
1	Valve, oil drain	249437
1	Clip, hose	267959

Figure 1. Installing Kit

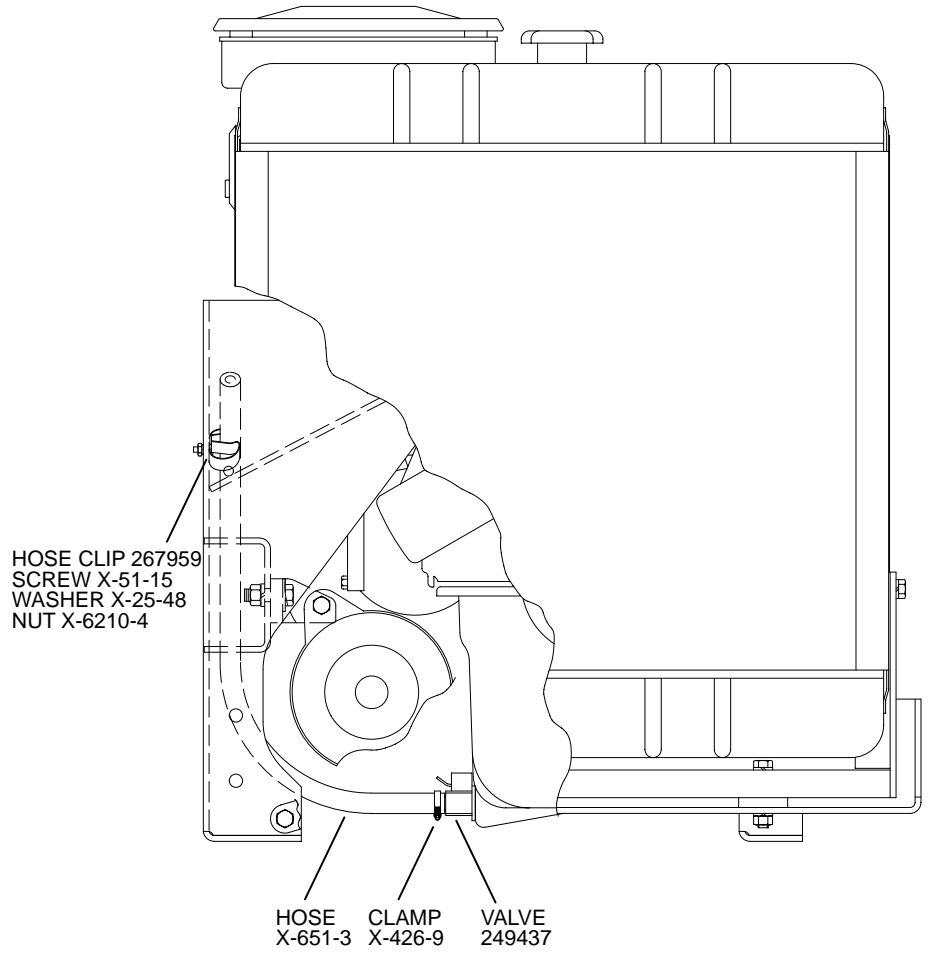
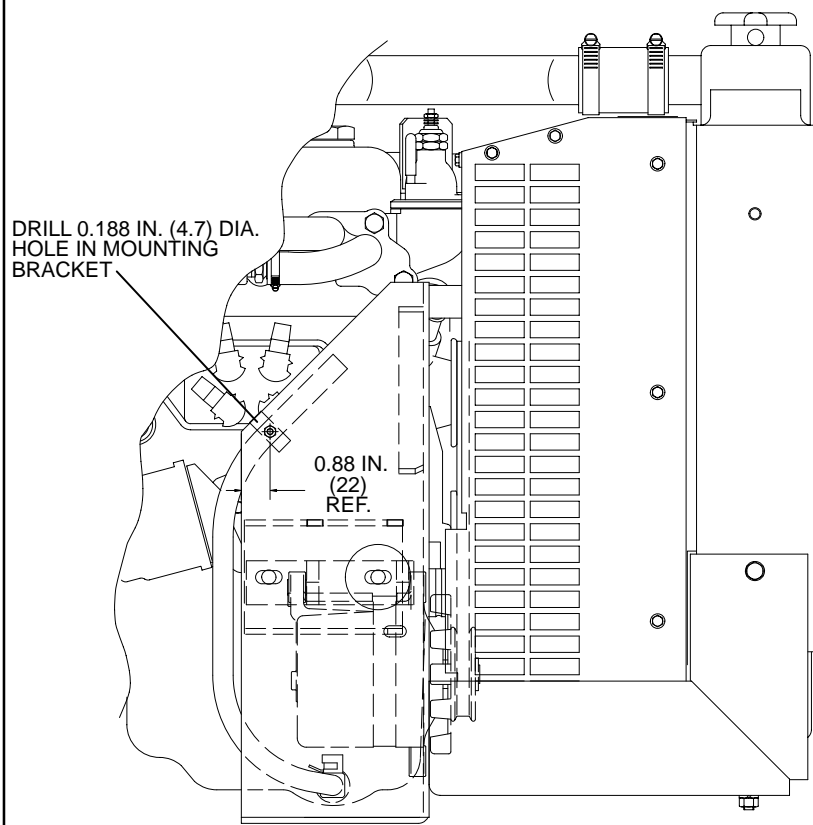

FV-255000-

NOTE: DIMENSIONS IN ( ) ARE MILLIMETER EQUIVALENTS