



Remote Start and Two-Meter Panel Kit PA-225585 **7CCO, 10CCO, 15CCO, and 20CCO** **RV Generator Sets**

Allows starting-stopping from a location remote of the generator set. Kit includes engine oil pressure gauge and water temperature gauge. Gauges are illuminated and the generator comes equipped with a 6-pin connector on the controller back panel for connection of the kit.

Start-Stop/Preheat Switch: Rocker-type switch with “ON” light used to start and stop generator set.

During cold weather starts:

7CCO and 10CCO (below 50°F [10°C]),
15CCO and 20CCO (below 23°F [-5°C]),
place controller start switch in STOP/PREHEAT position for 15-20 seconds before attempting to start generator set. This provides energizing of the *glow plugs* on the 7/10kW or the *air heater coil* on the 15/20kW.



WARNING

Accidental starting.

Can cause severe injury or death.

Disconnect battery cables before working on generator set (negative lead first and reconnect it last).

NOTE

Do not place Start - Stop/Preheat Switch in Stop/Preheat position for more than 30 seconds or damage may occur to preheat feature.

Engine Oil Pressure Gauge: Measures engine oil pressure.

NOTE

During the engine break-in period, it is normal for the engine to produce higher oil pressure readings. Consult your Operator's Manual for specific values.

Water Temperature Gauge: Measures engine coolant temperature.

Accidental starting can cause severe injury or death. Disconnect battery cables (remove negative lead first and reconnect it last) to disable generator set before working on any equipment connected to generator. The generator set can be started by remote start/stop switch unless this precaution is followed.

INSTALLATION

1. Disconnect battery, negative lead first.
2. Determine where in the vehicle the remote panel is to be mounted. This decision will be limited by the length of the wiring harness and the size (including mounting depth) of the panel.

NOTE

If additional wiring is needed, order an additional Remote Extension Harness Kits PA-225580, 15 ft. (4.6 m) or PA-225581, 25 ft. (7.6 m). Do not have remote harness kits exceed 75 ft. (22.9 m) in length. See Figure 1.

See Figure 2 for mounting dimensions. The minimum mounting clearance beyond the panel is 2-3/4 in. (70 mm). See Figure 3 for the panel assembly wiring.

3. Connect Remote Extension Harness PA-225580 or PA-225581 to remote panel and mount panel using four screws (not supplied).
4. Connect the other end of Remote Extension Harness PA-225580 or PA-225581 to the back of generator set controller.
5. Reconnect the battery, negative lead last. Start/stop generator set using controller switch and remote switch. Monitor gauges for proper function. STOP generator set.

Parts Listing

Description	Qty.	Part Number
Panel, Remote Start and Meter Panel	1	A-225584
Gauge, Water Temperature	1	249440
Gauge, Oil Pressure	1	249438
Harness, Panel Wiring	1	249331
Panel, Cutout	1	225583
Switch, Rocker	1	249330

225580-

Remote Extension Harness (Circled Numbers indicate lead numbers.)

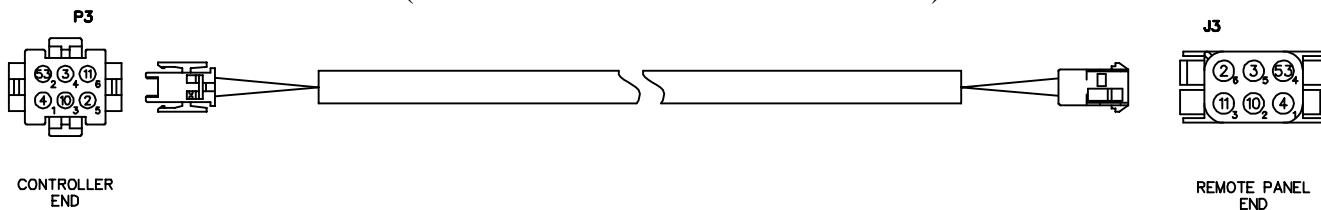

Connectors are shown as viewed
from terminal insertion end.

Figure 1. Remote Extension Harness PA-225580 or PA-225581

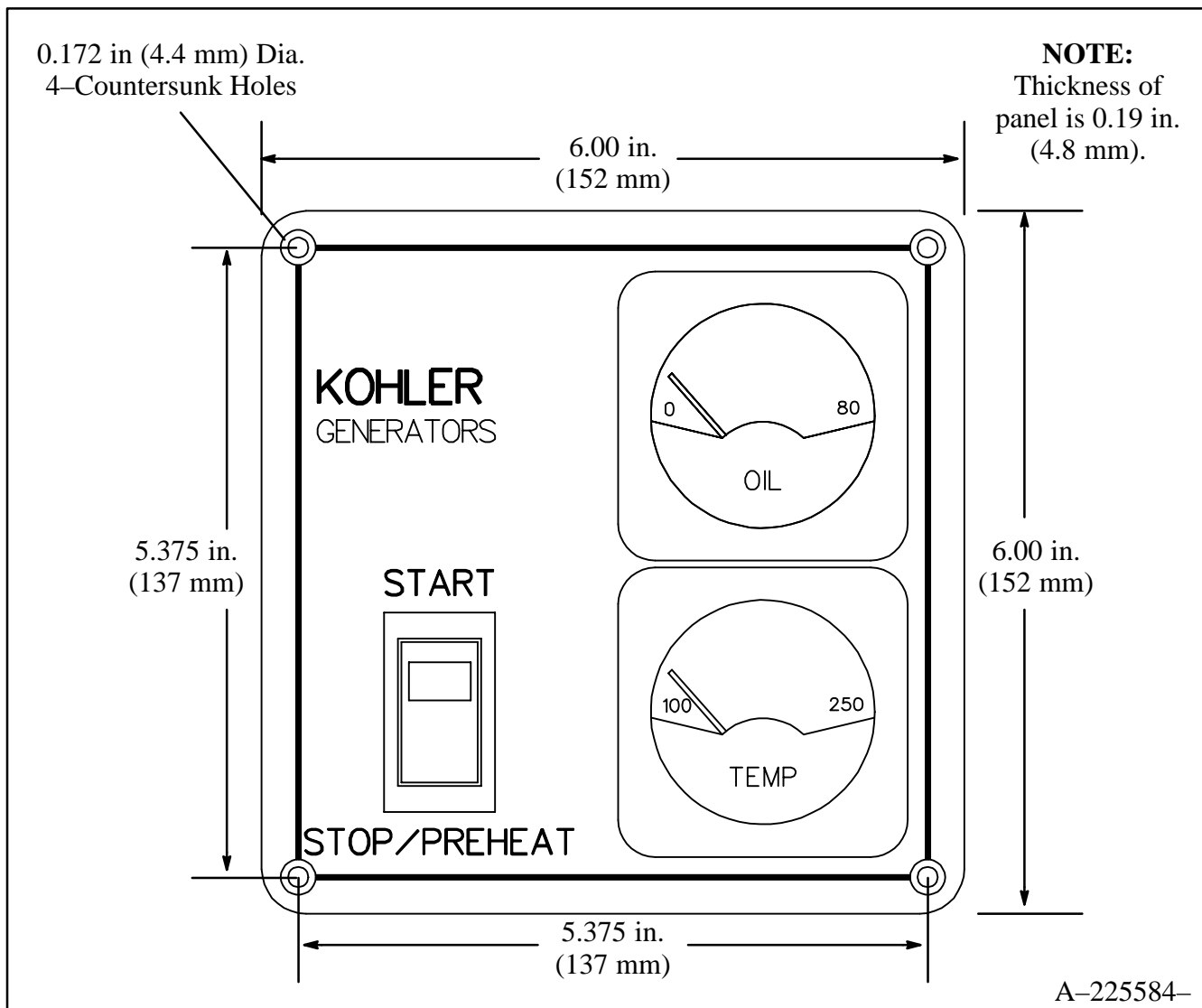
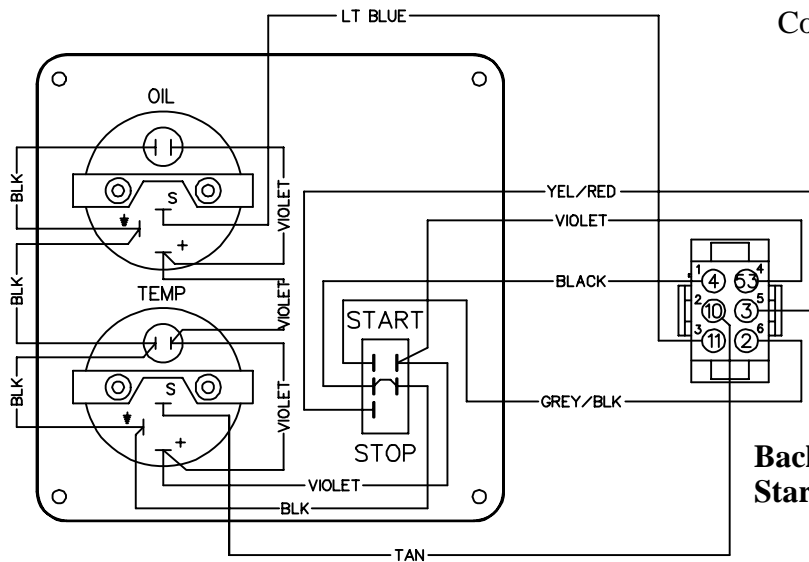

Figure 2. Meter Panel Mounting Dimensions

NOTE:
Connector shown from
pin insertion end.



**Back view of Remote
Start and Meter Panel.**

A-225584-

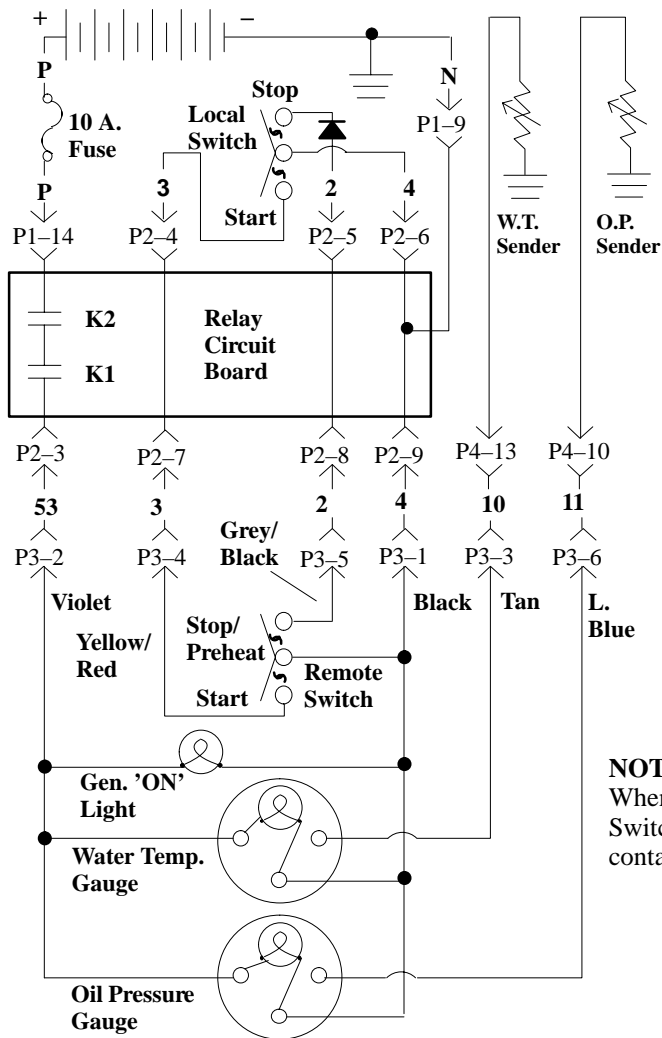

NOTE:
When the Start-Stop/Preheat
Switch is in the start position,
contacts 3 and 4 are closed.

Figure 3. Electrical Connections