INSTALLATION INSTRUCTIONS

Issue Date: **12/93**
 Model: **7CCO and 10CCO**
 Market: **RV**
 Subject: **Gauge Sender Kit PA-225618**

This kit provides gauge senders for the Remote Start and Two-Meter Panel Kit and Remote Start and Four-Meter Panel Kit. The senders convert the engine water temperature and oil pressure to signals used by the gauges to provide the operator with a visual indication of engine status.



Accidental starting.
Can cause severe injury or death.

Disconnect battery cables before working on generator set (negative lead first and reconnect it last).

Accidental starting can cause severe injury or death.

Disconnect battery cables (remove negative lead first and reconnect it last) to disable generator set before working on any equipment connected to generator set. The generator set can be started by the remote start/stop switch unless this precaution is followed.

⚠ WARNING



Hot coolant and steam.
Can cause severe injury or death.

Before removing pressure cap, stop generator set and allow it to cool. Then loosen pressure cap to relieve pressure.

⚠ WARNING



Hot engine and exhaust system.
Can cause severe injury or death.

Do not work on generator set until it is allowed to cool.

Hot coolant can cause severe injury or death. Allow engine to cool and release pressure from cooling system before opening pressure cap. To release pressure, cover the pressure cap with a thick cloth; then slowly turn it counterclockwise to the first stop. Remove cap after pressure has been completely released and the engine has cooled. Check coolant level at tank if generator set is equipped with a coolant recovery tank.

Hot parts can cause severe injury or death. Do not touch hot engine parts. An engine gets hot while running and exhaust system components get extremely hot.

Installation

1. Move the controller Start/Stop switch to the Stop position and allow the generator set to cool.
2. Disconnect the generator set battery, negative (-) lead first.
3. With the generator set cooled, drain the coolant into a suitable container. Locate the coolant drain at the bottom of the radiator and on the engine block. Refer to the Operation Manual for additional information regarding coolant drain locations.

NOTE

It is not necessary to drain all coolant in order to install the engine water temperature sender. Drain just enough coolant to prevent coolant leakage from the coolant hole. See Figure 1 for location of water temperature sender. Dispose of used coolant in an environmentally safe manner.

- 4. Remove low oil pressure switch (retain for later use) and pipe plug for engine water temperature sender. See Figure 1 for locations.
- 5. Install the engine water temperature sender (249348). See Figure 1 for location.

NOTE

Use pipe sealant on all threaded connections to prevent leakage.

- 6. Install sender adapter (225307) in the low oil pressure switch location on the engine block. Install the oil pressure sender (344305) and the low oil pressure switch in the sender adapter. See Figure 1, Detail A.
- 7. Connect the leads of the wiring harness to the gauge senders:
 - Lead 11 to the oil pressure sender
 - Lead 1 to the low oil pressure switch
 - Lead 10 to the water temperature sender
 See Figure 2. Keep leads away from exhaust system, sharp edges, and moving parts. Use cable ties (not supplied) to secure leads if necessary.

NOTE

Locate sender leads inside the wiring harness. Open the plastic conduit near the senders and locate the appropriate leads. A one- or two-digit number/letter at 3-in. (8-cm) intervals identifies each lead.

- 8. Close the coolant drain petcocks and fill the cooling system with fresh coolant. Refer to the Operation Manual for coolant specifications and capacity.

NOTE

Engine Damage! Failure to bleed air from cooling system may cause overheating and subsequent damage to engine.

NOTE

Pay special attention to the coolant level. After the coolant has been drained, allow time for complete refill of the engine water jacket. Check coolant level as prescribed in the Prestart Checklist of the Operation Manual.

- 9. Reconnect the generator set battery, negative lead last.
- 10. Test run the generator set for a few minutes and check for leaks at the senders. Start/stop the generator set using the controller switch and the remote switch. Monitor the gauges for functionality. Stop the generator set.

Parts List		
KIT PA-225618		
Qty.	Description	Part Number
1	Sender, water temperature	249348
1	Sender, oil pressure	344305
1	Adapter, oil sender	225307

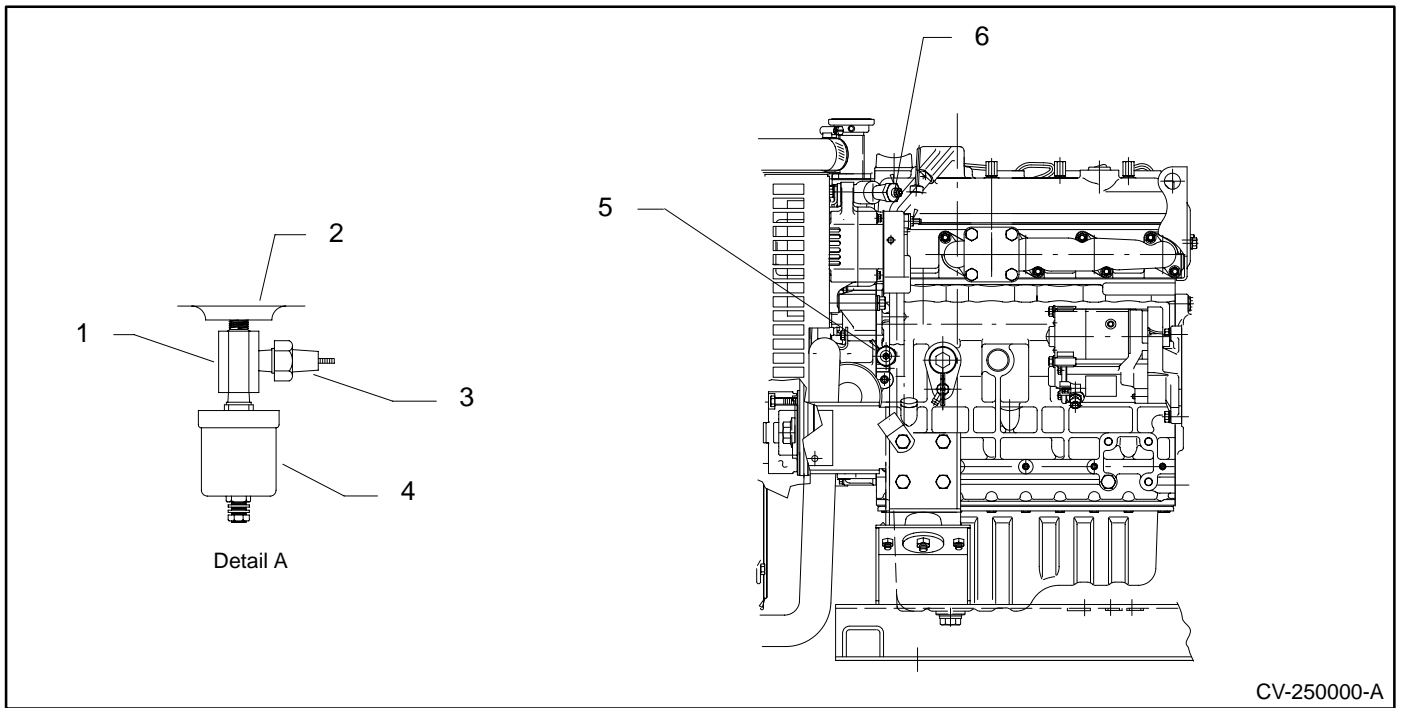

CV-250000-A

- 1. Oil sender adapter (225307)
- 2. Engine block
- 3. Relocate oil pressure switch to this location
- 4. Oil pressure sender (344305)
- 5. See detail A
- 6. Engine water temperature sender (249348)

Figure 1. Gauge Sender Locations

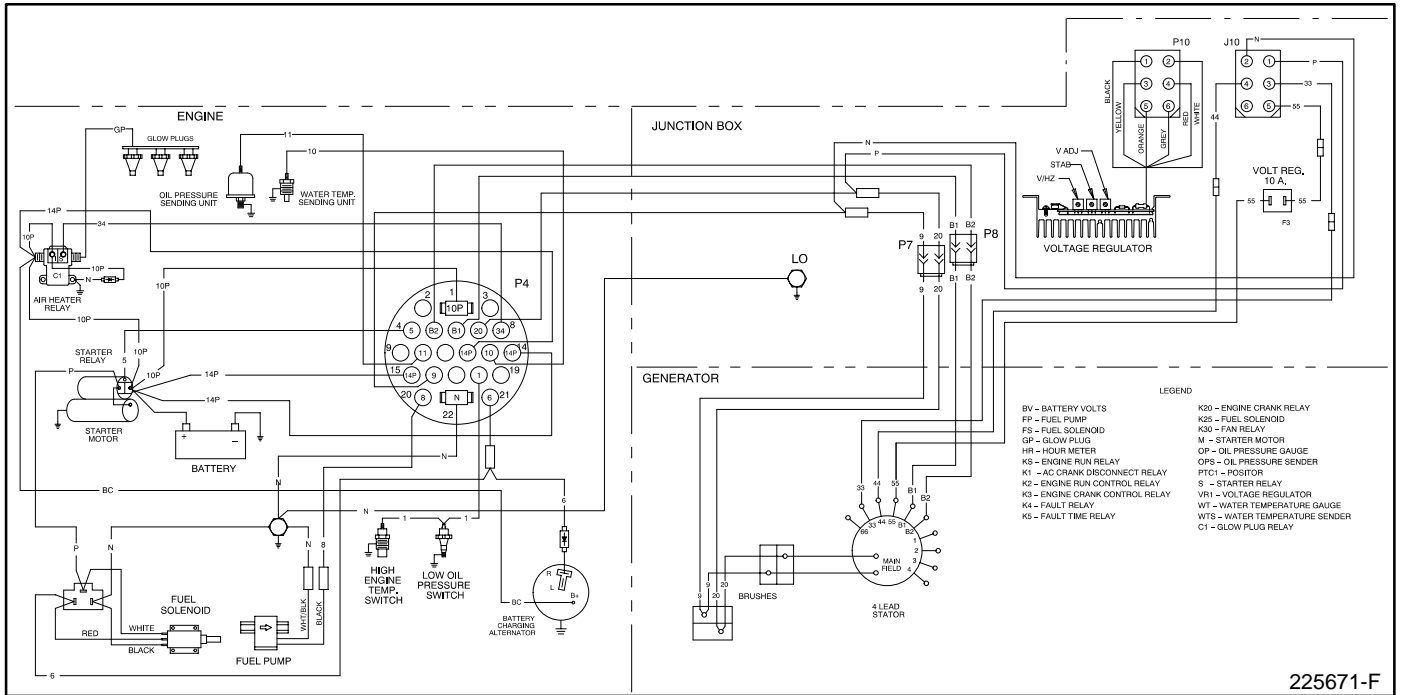

225671-F

Figure 2. Wiring Diagram of 225671