



INSTRUCTIONS

Fuel/Water Separator Kit PA-225624 7/10CCO-RV Generator Sets

The fuel/water separator is used to drain accumulated water and sediment from the fuel system. Observe all safety precautions during kit installation. After the kit is installed verify that all connections are tight. For additional information on the fuel system, consult the Operation and Installation Manual TP-5594.

WARNING

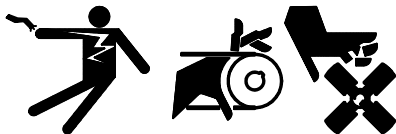

Accidental starting.

Can cause severe injury or death.

Disconnect battery cables before working on generator set (negative lead first and reconnect it last).

Accidental starting can cause severe injury or death. Disconnect battery cables (remove negative lead first and reconnect it last) to disable generator set before working on any equipment connected to generator. The generator set can be started by remote start/stop switch unless this precaution is followed.

WARNING



Explosive fuel vapors.

Can cause severe injury or death.

Use extreme care when handling, storing, and using fuels.

Explosive fuel vapors can cause severe injury or death. All fuels are highly explosive in a vapor state. Use extreme care when handling, storing, and using fuels. Store fuel in a well-ventilated area away from spark-producing equipment and out of the reach of children. Never add fuel to the tank while the engine is running since spilled fuel may ignite on contact with hot parts or from ignition spark. Do not smoke or permit flame or spark to occur near potential sources of spilled fuel or fuel vapors. Keep fuel lines and connections tight and in good condition—don't replace flexible fuel lines with rigid lines. Flexible sections are used to avoid breakage due to vibration. Should any fuel leakage, fuel accumulation, or electrical sparks be noted, DO NOT OPERATE GENERATOR SET. Have systems repaired before resuming generator operation.

Explosive fuel vapors can cause severe injury or death. Spilled fuel can cause an explosion. Use a container to catch fuel when draining fuel system. Wipe up all spilled fuel after draining system.

INSTALLATION

1. Disconnect battery, negative cable first.
2. Install bracket (225604) on engine with two 10 mm screws (X-6068-1). See Figure 1.
3. Loosen two hose clamps and remove existing hose between fuel pump and fuel filter. Discard hose. Save clamps for reuse with kit installation.
4. Install water separator (225251) on bracket with two 1/4-20 x 0.75 screws (X-465-16) and two 1/4-in. washers (X-25-40). See Figure 2.

NOTE

Apply thread sealant to threaded fuel connections.

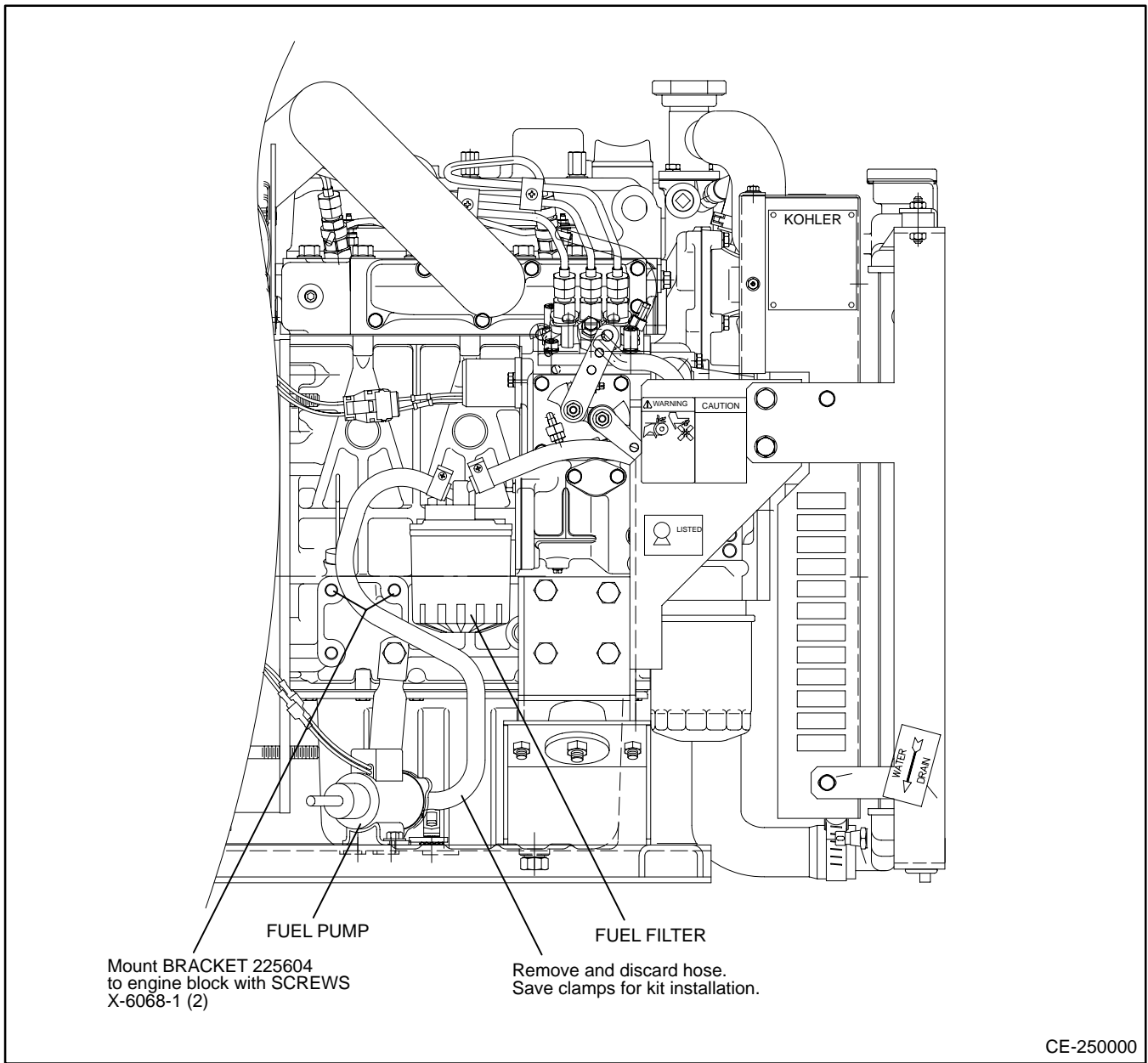

Figure 1. Install Water Filter Mounting Bracket

5. Install two hose connectors (X-391-25) in ports 2 and 3 of water separator. Install pipe plugs (X-75-41) in ports 1 and 4.
6. Install 7-in. (17.8 cm) hose (X-386-101) between fuel filter and port 2 (outlet) of water separator. Install clamp saved from fuel hose removal at filter end of hose. Install new clamp (X-426-9) at water separator end of hose. Locate clamps 1/4 in. (6.3 mm) from hose ends and tighten clamps.
7. Install 10-in. (25.4 cm) hose (X-386-95) between fuel pump and port 3 (inlet) of water separator. Install clamp saved from fuel hose removal at fuel pump end of hose. Install new clamp (X-426-9) at water separator end of hose. Locate clamps 1/4 in. (6.3 mm) from hose ends and tighten clamps.
8. Connect battery, negative cable last. Run generator and check for leaks.

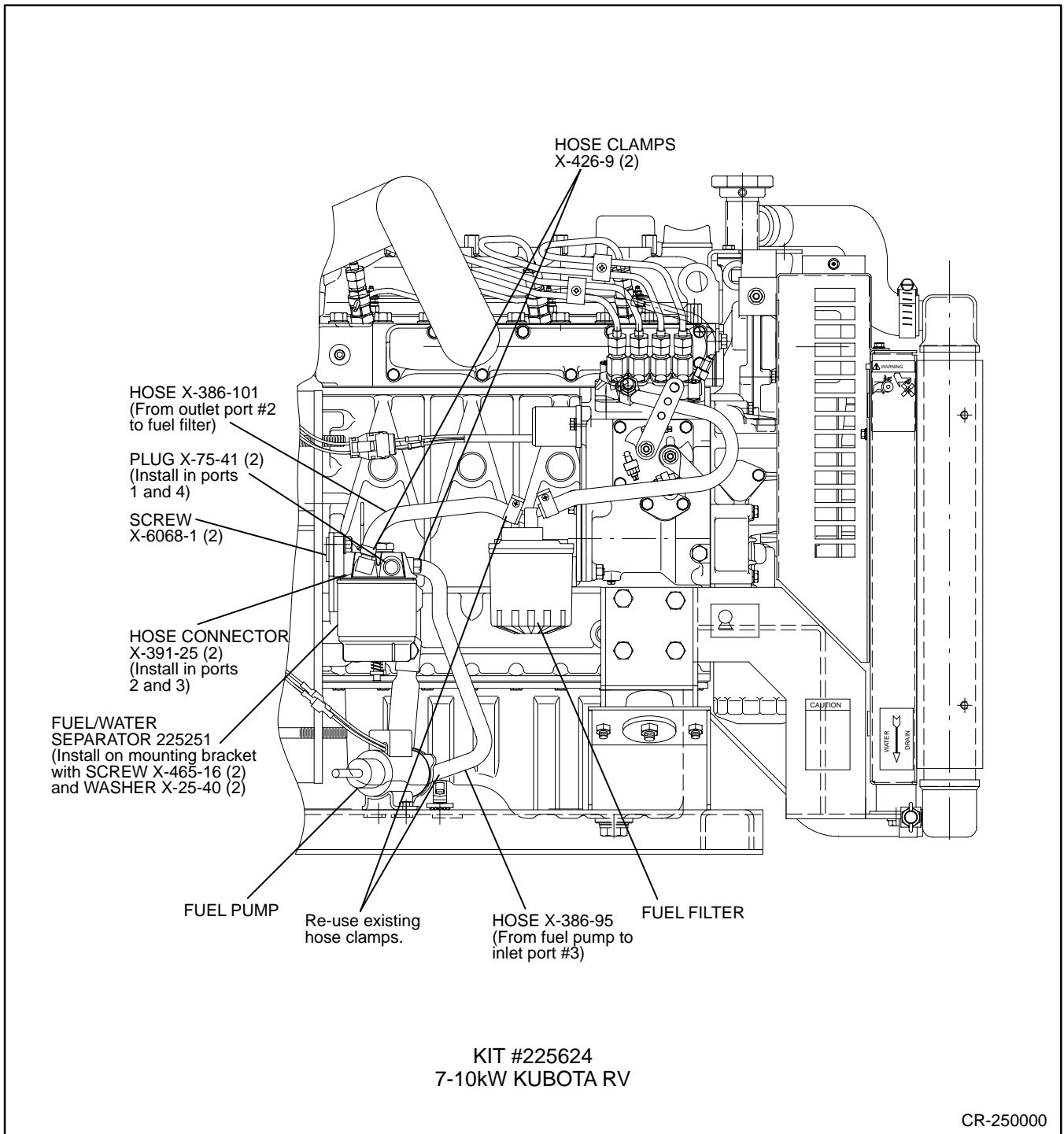

Figure 2. Installing Fuel/Water Separator

DRAINING WATER FILTER

At the specified interval (consult generator service manual), drain water from fuel/water separator. Hold a suitable container beneath the fuel/water separator and push up on the drain valve (see Figure 3). Release valve when fuel (free of water) flows from fuel/water separator.

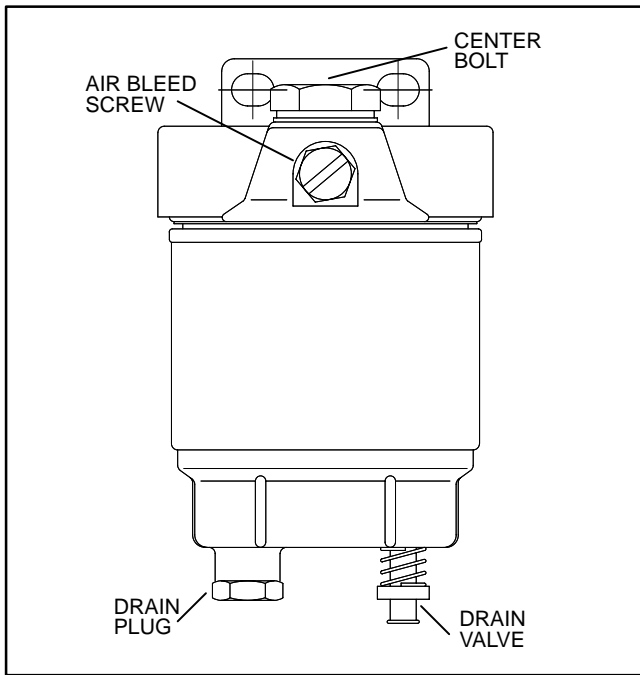

Figure 3. Draining and Changing Water Filter

CHANGING WATER FILTER

At the specified interval, replace the water separator element using the following procedure.

1. Close fuel valve at nearest point to water filter inlet or at fuel tank.
2. Remove water drain plug (or push up drain valve) and allow water and fuel to flow into a suitable container.

NOTE

Depending upon location of fuel valve, a considerable amount of fuel may drain out.

3. Remove center bolt and remove fuel/water separator element from mounting head with bowl connected.

4. Remove the bowl from the fuel/water separator element. Wipe excess fuel oil from bowl and O-ring. Do not discard bowl or O-ring.
5. Inspect components for wear or damage. Replace parts as necessary.
6. Lubricate the O-ring with clean diesel fuel or motor oil and replace in the bowl.
7. Install bowl onto a new fuel/water separator filter element.

NOTE

Kohler service replacement fuel/water separator element part number is #225259.

8. Lubricate bowl/element assembly with clean fuel oil. Install bowl/element onto filter mounting head. Tighten center bolt to 65 inch-pounds.
9. Replace water drain plug (if removed) and close vent.
10. Remove air bleed screw from fuel/water separator.
11. Open fuel supply valve.
12. After fuel oil fills water separator allow fuel to flow from air bleed hole until all air is displaced (fuel flows free of air bubbles). Replace air bleed screw.

Parts List

| Qty. | Description | Part Number |
|------|---------------------------------------|-------------|
| 2 | Washer, plain, 0.281 x 0.625 x 0 .065 | X-25-40 |
| 1 | Line, flex fuel, 7" | X-386-101 |
| 1 | Line, flex fuel, 10" | X-386-95 |
| 2 | Connector, hose | X-391-25 |
| 2 | Clamp, hose | X-426-9 |
| 2 | Screw, hardened, 1/4-20 x 0.750 | X-465-16 |
| 2 | Screw, M-10-1.50 x 60 mm | X-6068-1 |
| 2 | Plug, pipe | X-75-41 |
| 1 | Filter, water separator | 225251 |
| 1 | Bracket, filter separator | 225604 |