

KOHLER® POWER SYSTEMS



INSTALLATION INSTRUCTIONS

PowerBoost™ V Voltage Regulator Kit 229830 For 25 and 32 kW Marine Generator Sets

Use the PowerBoost™ V voltage regulator kit to replace voltage regulator (255937) on 25 and 32 kW marine generator sets built before 1993. The PowerBoost™ V regulator has an underfrequency unloading characteristic. It is designed to maintain generator rated output voltage under any load unless the generator engine speed drops below a pre-set level (factory setting 57.5 Hz on 60 Hz models and 47.5 Hz on 50 Hz models). At this point, the regulator allows the generator voltage and current to drop to a level at which the engine can handle the load. As the engine speed returns to normal as load is accepted, generator output also returns to normal. Observe the following safety precautions when installing the PowerBoost™ V voltage regulator kit.

WARNING

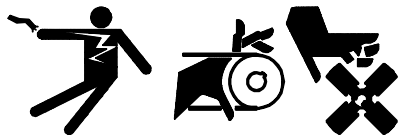

Accidental starting.

Can cause severe injury or death.

Disconnect battery cables before working on generator set (negative lead first and reconnect it last).

Accidental starting can cause severe injury or death. Disconnect battery cables (remove negative lead first and reconnect it last) to disable generator set before working on any equipment connected to generator. The generator set can be started by remote start/stop switch unless this precaution is followed.

WARNING



Hazardous voltage.



Moving rotor.

Can cause severe injury or death.

Do not operate generator set without all guards and electrical enclosures in place.

Hazardous voltage can cause severe injury or death. Wherever electricity is present, there is the hazard of electrocution. Take the same precautions with electrical appliances in your craft that you would observe in your home. Open main circuit breaker on all power sources before servicing equipment. Make sure unqualified persons, especially children, cannot gain access to your set—keep the compartment door locked or securely latched at all times. Be sure that generator is properly grounded. Never touch electrical leads or appliances with wet hands, when standing in water, or on wet ground as the chance of electrocution is especially prevalent under such conditions.

⚠ WARNING

<p>Hazardous voltage. Backfeed to utility system can cause severe injury, death, or property damage.</p> <p>Do not connect to any building electrical system without connecting through an approved device and after building main switch is open.</p>



Hazardous voltage can cause severe injury or death. Short circuits can cause bodily injury and/or equipment damage. Do not contact electrical connections with tools or jewelry while adjustments are made. Remove wristwatch, rings, and jewelry that can cause short circuits.

INSTALLATION

1. Move controller master switch to OFF position. Disconnect generator set battery cables, negative lead first.
2. Remove junction box rear cover. See Figure 1.
3. Disconnect leads from voltage regulator board. Label each lead for reconnection purposes. Remove the voltage regulator.
4. Using the mounting plate (229828) as a template, drill three 0.312-inch (7.9-mm) diameter holes in junction box end cover at the locations shown in Figure 1, View A-A.
5. Attach the mounting plate to junction box end cover with three 1/4-20 x 1.00-in. hex screws (X-465-7), 0.281 x 0.500 x 0.375-in. spacers (265861), and whiz nuts (X-6210-2).

6. Install voltage regulator circuit board (B-258296) to mounting plate with six 8-32 x 0.625-in. r.h.m. screws (X-51-9), nylon washers (239665), and #8 x 0.250 x 0.250-in. fiber spacers (X-712-2).
7. Connect generator leads to voltage regulator as shown in wiring diagram, Figure 2.
8. Reconnect generator set battery cables, negative lead last. Adjust voltage regulator according to following procedure.

POWERBOOST™ V ADJUSTMENT PROCEDURE

⚠ WARNING	
	
Hazardous voltage.	Moving rotor.
Can cause severe injury or death.	
Do not operate generator set without all guards and electrical enclosures in place.	

Hazardous voltage can cause severe injury or death. The heat sink of the voltage regulator contains high voltage. Do not touch voltage regulator heat sink when testing or electrical shock will occur.
(PowerBoost, PowerBoost III, and PowerBoost V Voltage Regulator Models only.)

Adjust the PowerBoost™ V voltage regulator as described in the following steps. Voltage regulator components are identified in Figure 3 and described in the following paragraphs. Before beginning adjustment procedure, verify engine speed is properly set (60 Hz or 50 Hz). Adjust engine speed (if necessary) according to the procedure outlined in the engine service manual.

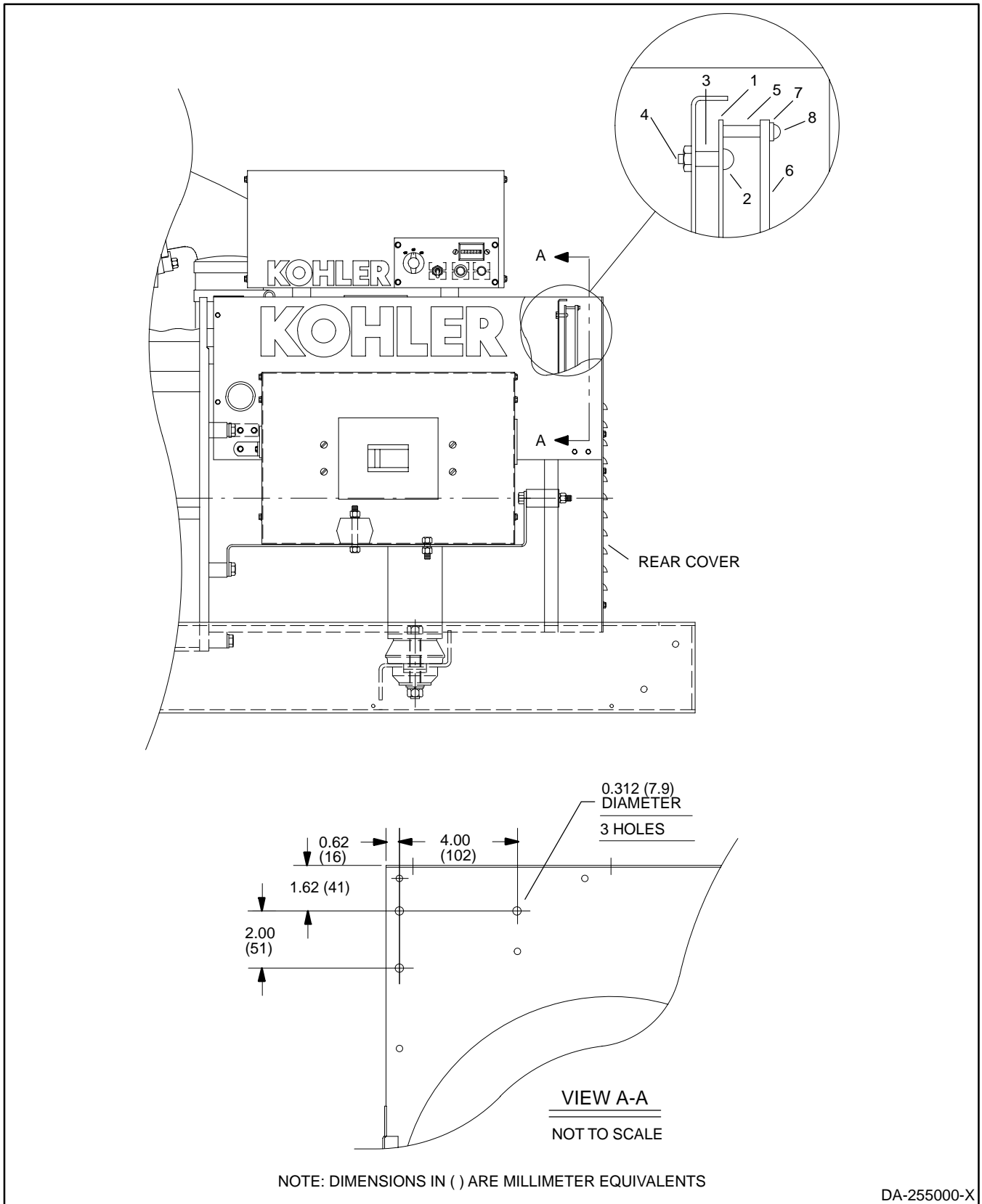

- | | |
|---------------------------------|------------------------------------|
| 1. Mounting Plate (229828) | 5. Fiber Spacer (X-712-2) (qty. 6) |
| 2. Hex Screw (X-465-7) (qty. 3) | 6. Circuit Board (B-258296) |
| 3. Spacer (265861) (qty. 3) | 7. Nylon Washer (239665) (qty. 6) |
| 4. Whiz Nut (X-6210-2) (qty. 3) | 8. R.H.M. Screw (X-51-9) (qty. 6) |

Figure 1. PowerBoost™ V Voltage Regulator

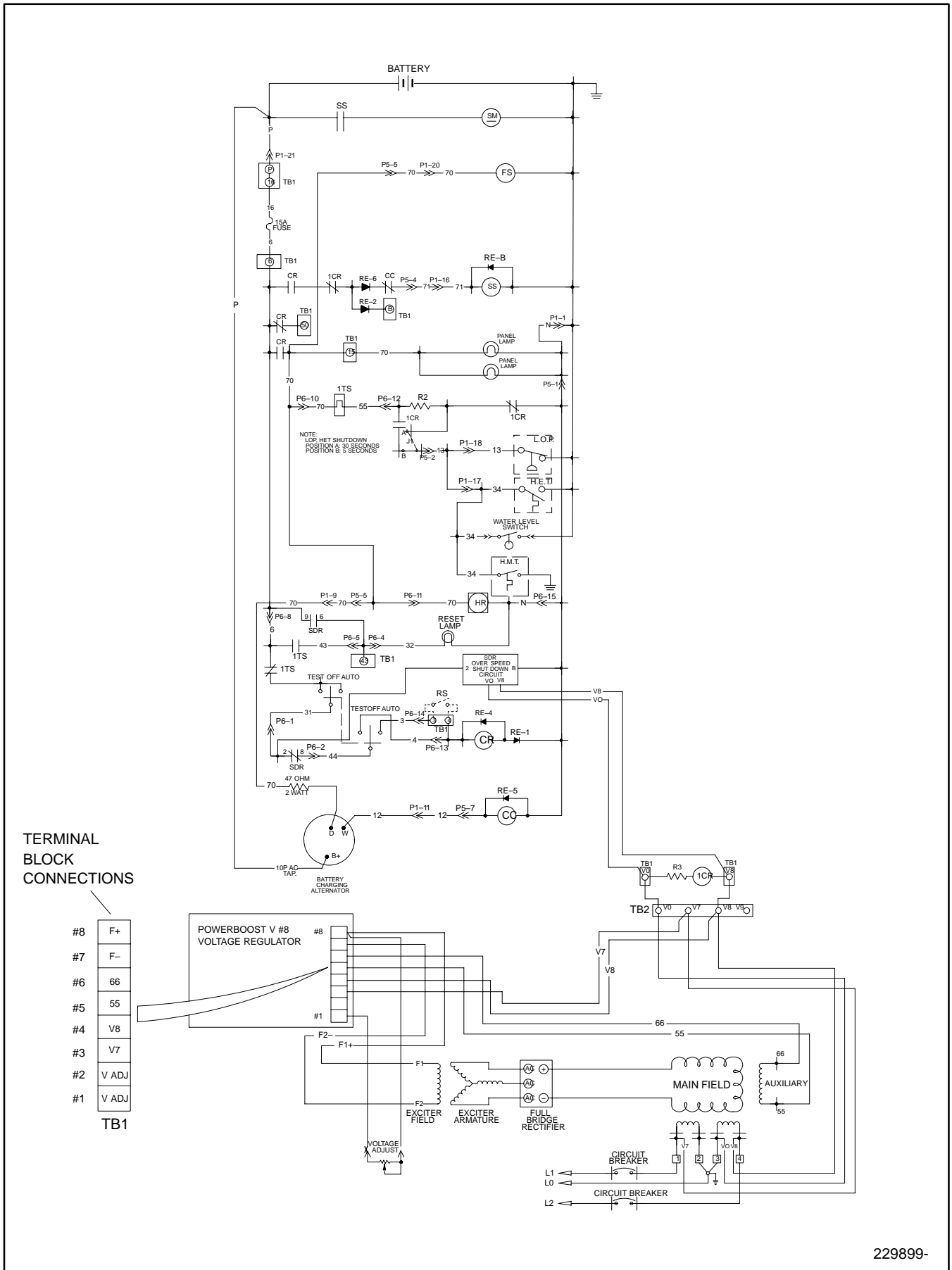

229899-

Figure 2. Wiring Diagram

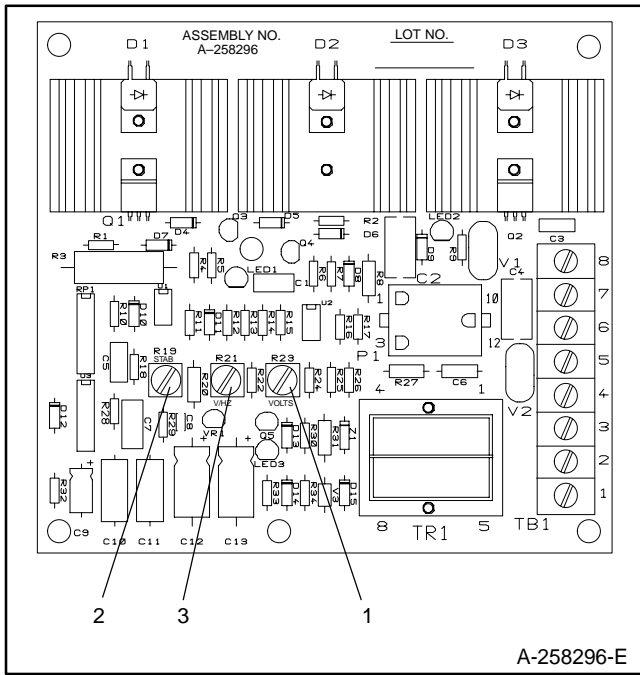

1. Voltage Adjustment Potentiometer (VOLTS)
2. Stabilizer Potentiometer (STAB)
3. Volts/Hz Potentiometer (V/HZ)

Figure 3. PowerBoost™ V Voltage Regulator Adjustments

Voltage Adjustment Potentiometer (VOLTS): Adjusts generator output voltage within a range of 190 to 270 volts or 95 to 135 volts.

NOTE

A customer-supplied rheostat connected across regulator terminals 1 and 8 will allow adjustment of the generator output from a location remote from the

generator set. The rheostat (10k ohms, 1/2 watt minimum) will provide a five-volt adjustment range.

Stabilizer Potentiometer (STAB): Fine-tunes the regulator circuit to reduce light flicker.

Volts/Hz Potentiometer (V/HZ): Adjustment determines engine speed (Hz) at which generator output will begin to drop.

NOTE

The regulator is factory set for 60 Hz and no adjustment is necessary.

1. With generator set off, disconnect all electrical loads from the generator set. If equipped, turn the remote rheostat and stability potentiometer to midpoint. Turn Volts and Volts/Hz potentiometers fully counterclockwise. Connect voltmeter to AC circuit or an electrical outlet powered by the generator set.
2. Start generator set. Rotate voltage adjustment potentiometer clockwise (increase voltage) or counterclockwise (decrease voltage) until desired output voltage is achieved.
3. Rotate stability potentiometer clockwise until minimum light flicker is obtained.
4. Readjust voltage adjustment potentiometer (if necessary).
5. Adjust engine speed to desired cut-in frequency by adjusting the governor on the engine. (See engine service manual.) The recommended cut-in frequency is 57.5 Hz for 60 Hz operation and 47.5 Hz for 50 Hz operation (as measured on frequency meter).

6. Rotate Volts/Hz adjustment potentiometer clockwise until voltage level just begins to drop (as measured on voltmeter).

NOTE

When set to these specifications, the generator will attempt to maintain normal voltage (as set in steps 2, 4, and 9) until the engine speed drops below the frequency set in step 5 (as load is applied).

7. Readjust engine speed to rated speed.
8. Readjust stability potentiometer (if necessary).

9. Readjust voltage adjustment potentiometer (if necessary).
10. If equipped, use remote rheostat to make final voltage adjustments. Stop generator set.
11. Reinstall junction box cover.
12. The Light Emitting Diodes (LED1—green, LED2—red, and LED3—yellow) are used for troubleshooting only, not as set-up indicators. If the generator fails to operate correctly, consult your local Kohler dealer/distributor or Service Specialist for troubleshooting guidelines.

Parts List		
Kit 229830		
Qty.	Description	Part Number
1	Circuit Board Assembly, voltage regulator	B-258296
3	Screw, 1/4-20 x 1.00 in. hex	X-465-7
6	Screw, 8-32 x 0.625 in. r.h.m.	X-51-9
3	Nut, 1/4-20 whiz	X-6210-2
6	Spacer, #8 x 0.250 x 0.250 in. fiber	X-712-2
1	Plate, mounting	229828
6	Washer, 0.192 x 0.322 x 0.031 in. nylon	239665
3	Spacer, 0.281 x 0.500 x 0.375 in.	265861