

INSTALLATION INSTRUCTIONS

Original Issue Date: 11/05

Model: 8.5/12RES, 15/30RES, 15/30RYG, 10/15/20REOD/REOZD,
10/15/20EORD/EORZD, 9/12.5/16.5EFORD/EFORZD

Market: Residential/Commercial, Mobile

Subject: Common Fault and Run Relay Board Kit GM30414-KP1

Introduction

The standard relay interface board (RIB) contains the K2 crank, K3 flash, and K5 run relays. The common fault and run relay board kit GM30414-KP1 provides two additional relays to control customer-provided equipment:

- K1 common fault relay
- K4 auxiliary run relay

The common fault/run relay board kit GM30414-KP1 includes the five-relay interface board and a connection harness. The kit replaces the standard three-relay interface board located in the junction box. See Figure 1 through Figure 3.

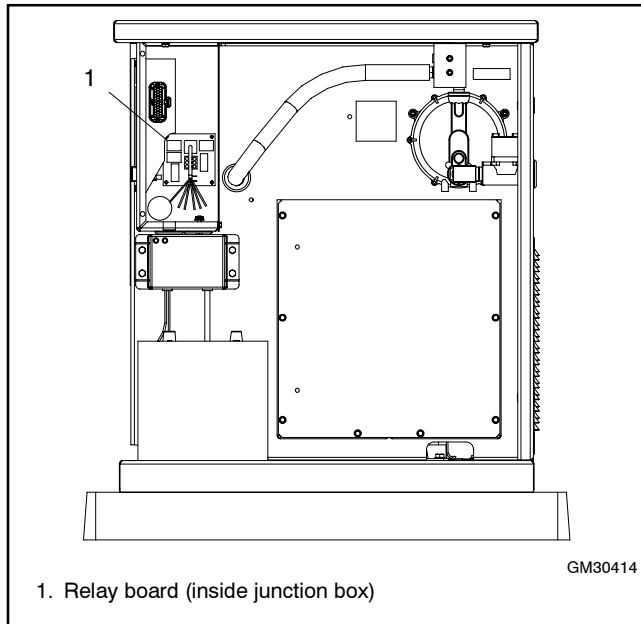

Figure 1 Relay Board Location, Models 8.5/12RES

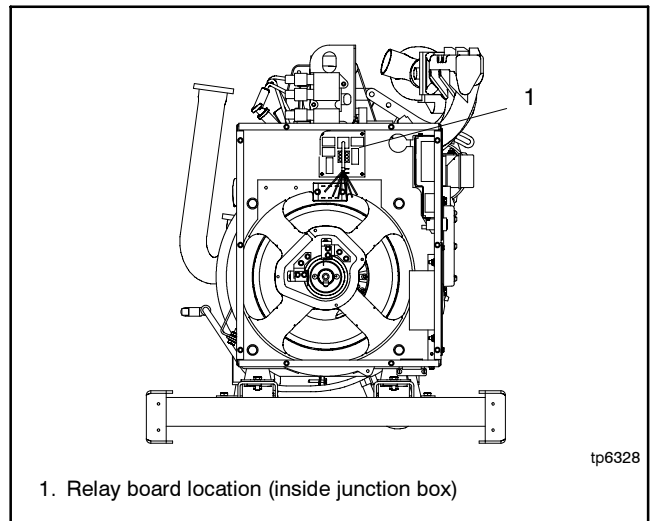

Figure 2 Relay Board Location, Models 15/30RES and 15/30RYG

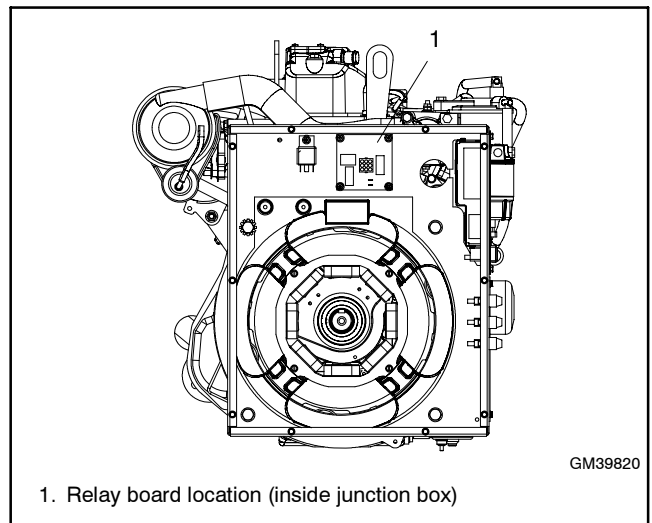
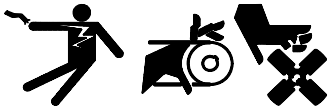

Figure 3 Relay Board Location, Models 10/15/20REOD/REOZD/EORD/EORZD

Safety Precautions

Observe the following safety precautions while installing the kit.

⚠ WARNING



Accidental starting. Can cause severe injury or death.

Disconnect the battery cables before working on the generator set. Remove the negative (-) lead first when disconnecting the battery. Reconnect the negative (-) lead last when reconnecting the battery.

Disabling the generator set. Accidental starting can cause severe injury or death. Before working on the generator set or connected equipment, disable the generator set as follows: (1) Move the generator set master switch to the OFF position. (2) Disconnect the power to the battery charger. (3) Remove the battery cables, negative (-) lead first. Reconnect the negative (-) lead last when reconnecting the battery. Follow these precautions to prevent starting of the generator set by an automatic transfer switch, remote start/stop switch, or engine start command from a remote computer.

Kits must be installed by an authorized distributor/dealer or representative. Read the entire installation procedure and compare the kit parts with the parts list before beginning installation. Perform the steps in the order shown.

Installation Procedure

Follow the Installation Procedure to remove the existing board and install board GM29779. Connect customer equipment to the relay board harness, GM30539.

1. Place the generator set master switch in the OFF position.
2. Disconnect the power to the battery charger, if equipped.
3. Disconnect the generator set engine starting battery(ies), negative (-) lead first.
4. Remove the junction box panel to locate the relay board mounted inside the junction box. See Figure 1, Figure 2, or Figure 3. Disconnect P14 and the brush/exciter leads FP and FN. See Figure 4.
5. Pull the board straight off the mounting standoffs.
6. Snap the new board GM29779 onto the standoffs.
7. Connect P14 and the brush/exciter leads FP and FN to the new board. See Figure 4.
8. Connect wiring harness GM30539 to plug P13 on the RIB. See Figure 4.

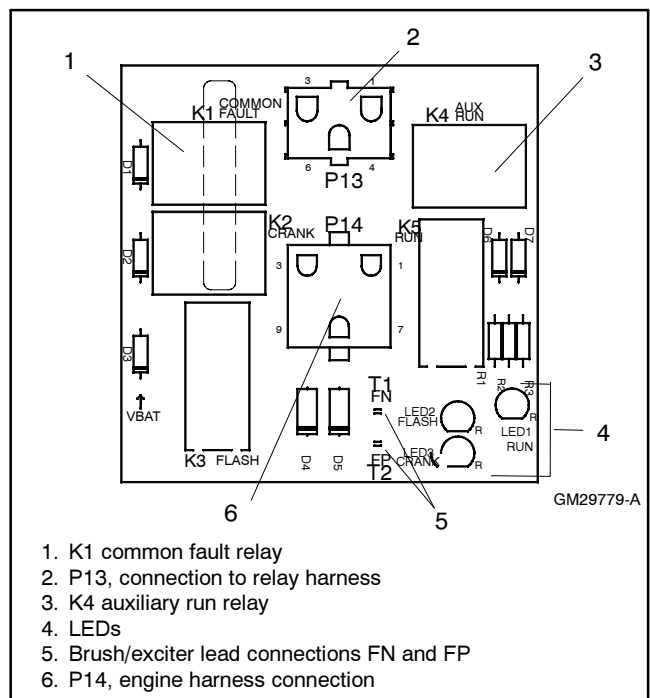

Figure 4 Run/Common Fault Relay Board GM29779

9. Connect the wiring harness leads to customer-supplied equipment. Connect to each relay's normally open or normally closed contacts depending on the application. See Figure 5 and the following section, Relay Operation. Also see the schematic diagram in Figure 6 for the model 8.5/12RES or the diagrams in the Installation Manual for other generator set models.
10. Replace the junction box panel.
11. Check that the generator set master switch is in the OFF position.
12. Reconnect the generator set engine starting battery, negative (-) lead last.
13. Reconnect power to the battery charger, if equipped.

| Harness Lead Number | Connector Pin Number | Connection |
|---------------------|----------------------|------------------------------|
| 88 | 6 | Common fault normally open |
| 89 | 2 | Common fault common |
| 90 | 3 | Common fault normally closed |
| 91 | 4 | Run relay normally open |
| 92 | 1 | Run relay common |
| 93 | 5 | Run relay normally closed |

Figure 5 Common Fault and Run Relay Board Harness Connections

Relay Operation

The auxiliary run relay is energized when the generator set is running.

The common fault relay is energized on any ADC controller fault, including:

- Auxiliary fault input shutdown
- High engine temperature shutdown
- Low coolant level
- Loss of coolant
- Low oil pressure shutdown
- Overcrank shutdown
- Overfrequency shutdown
- Overspeed shutdown
- Overvoltage shutdown
- Underfrequency shutdown
- Undervoltage shutdown
- High/low battery voltage warning

Some of the faults listed are not applicable to all generator set models. See the generator set Operation Manual.

Parts List

Run/Common Fault Relay, 12-Volt

| Kit: GM30414-KP1 | | |
|------------------|--|-------------|
| Qty. | Description | Part Number |
| 1 | PCB assembly, relay board, 12-volt with optional relay | GM29779 |
| 1 | Harness, wiring relay board | GM30539 |

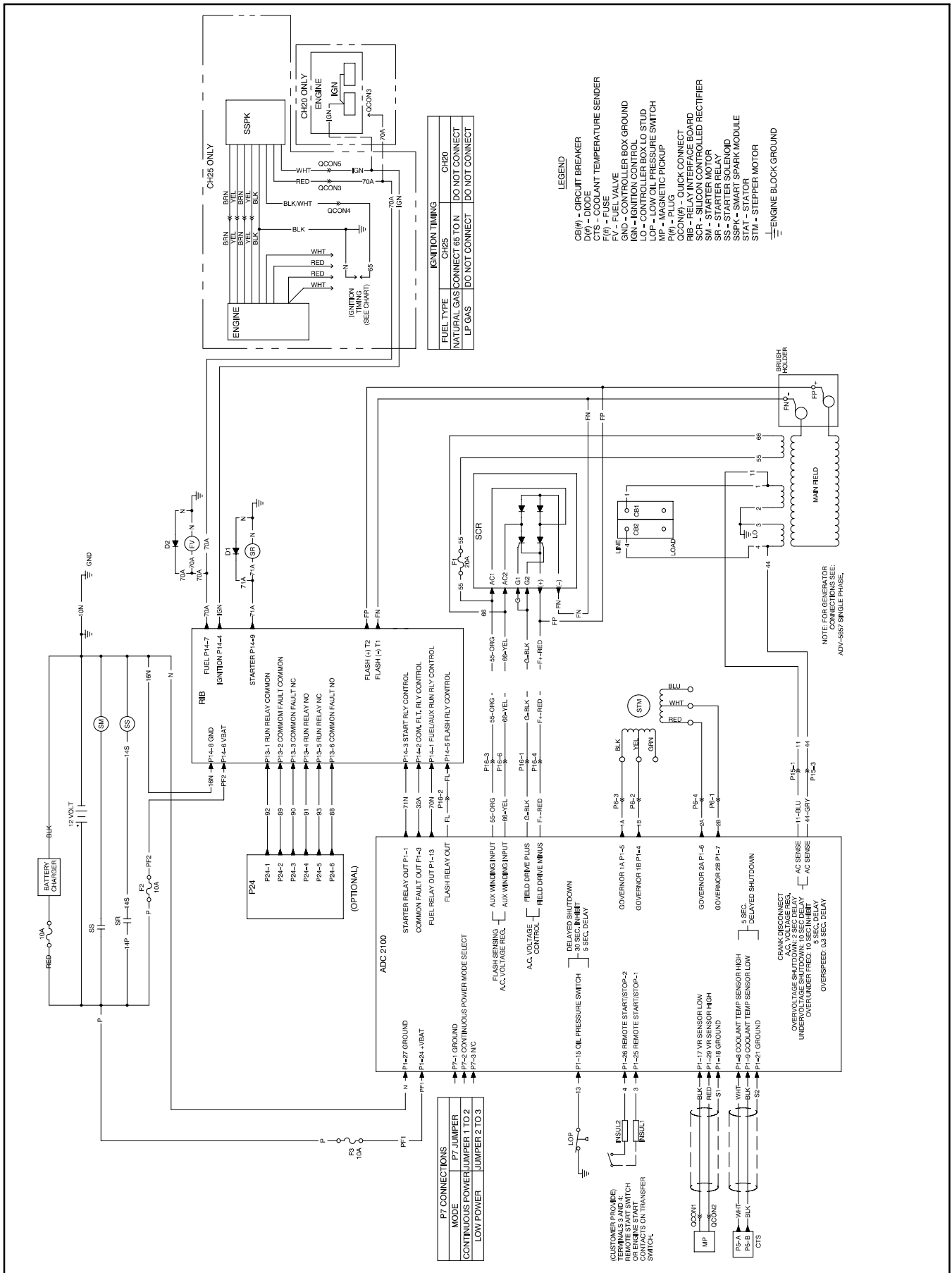

Figure 6 Schematic Diagram, ADV-6835A-E, Model 8.5/12RES