

# Operation and Installation

## Residential/Commercial Generator Sets

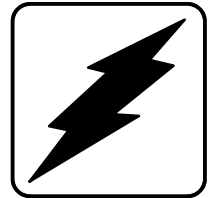

Models:

**8.5RES**

**12RES**

Controller:

Advanced Digital Control



**KOHLER**<sup>®</sup>  
POWER SYSTEMS

TP-6195 1/04



# Table of Contents

<b>Product Identification Information</b> .....	<b>Inside front cover</b>
<b>Safety Precautions and Instructions</b> .....	<b>I</b>
<b>Introduction</b> .....	<b>i</b>
<b>Service Assistance</b> .....	<b>ii</b>
<b>Section 1 Specifications and Features</b> .....	<b>1</b>
1.1 Specifications .....	1
1.2 Generator .....	1
1.3 Engine .....	1
1.4 Advanced Digital Control .....	1
1.5 Service Views .....	2
<b>Section 2 Operation</b> .....	<b>3</b>
2.1 Prestart Checklist .....	3
2.2 Exercising the Generator Set .....	3
2.3 Generator Set Operation .....	3
2.3.1 Controls and Indicators .....	4
2.3.2 Starting the Generator Set .....	4
2.3.3 Stopping the Generator Set .....	4
2.3.4 Fault Shutdowns .....	5
2.3.5 Resetting the Controller after a Fault Shutdown .....	6
2.3.6 Continuous Power Mode .....	6
2.4 Circuit Protection .....	7
2.4.1 Line Circuit Breaker .....	7
2.4.2 Fuses .....	7
2.5 Battery Charger .....	7
2.5.1 Battery Charger Operation .....	8
<b>Section 3 Scheduled Maintenance</b> .....	<b>9</b>
3.1 Routine Maintenance .....	9
3.2 Service Schedule .....	9
3.3 Lubrication System .....	11
3.3.1 Low Oil Pressure Shutdown .....	11
3.3.2 Oil Check .....	11
3.3.3 Engine Oil Recommendation .....	11
3.3.4 Oil Change Procedure .....	11
3.4 Spark Plugs .....	12
3.5 Air Cleaner Element and Precleaner .....	12
3.5.1 Precleaner Service .....	12
3.5.2 Paper Element Service .....	12
3.6 Cooling System .....	13
3.7 Exhaust System .....	14
3.8 Battery .....	14
3.8.1 Cleaning the Battery .....	15
3.8.2 Checking Battery Electrolyte Level .....	15
3.8.3 Checking Electrolyte Specific Gravity .....	16
3.9 Battery Charger .....	17
3.10 Storage Procedure .....	17
3.10.1 Lubricating System .....	17
3.10.2 Fuel System .....	17
3.10.3 Cylinder Lubrication .....	17
3.10.4 Exterior Preparation .....	17
3.10.5 Battery .....	18

# Table of Contents, continued

---

<b>Section 4 Troubleshooting</b> .....	<b>19</b>
4.1 Introduction .....	19
4.2 Generator Set Troubleshooting .....	19
4.3 Fault Codes .....	20
4.4 Controller Troubleshooting .....	20
4.5 Battery Charger Troubleshooting .....	20
<b>Section 5 Wiring Diagrams</b> .....	<b>21</b>
5.1 Specification Numbers .....	21
5.2 Controller Wiring Diagram Reference .....	21
<b>Section 6 Installation</b> .....	<b>25</b>
6.1 General .....	25
6.2 Weight .....	25
6.3 Generator Set Inspection .....	25
6.4 Mounting .....	25
6.5 Exhaust Requirements .....	25
6.6 Air Requirements .....	27
6.7 Power Supply .....	27
6.8 Fuel System .....	27
6.8.1 Fuel Supply .....	27
6.8.2 Fuel Pipe Size .....	28
6.8.3 Fuel Conversion .....	28
6.9 Electrical Connections .....	31
6.9.1 AC Load Lead Connections .....	31
6.9.2 Remote Start Connection (optional) .....	32
6.9.3 Continuous Power Mode Jumper .....	32
6.9.4 Battery .....	33
6.9.5 Battery Charger .....	34
6.10 Accessories .....	35
6.10.1 Common Fault and Run Relay Board .....	35
6.10.2 Carburetor Heater .....	36
6.11 Controller Configuration .....	37
6.11.1 System Configuration .....	37
6.11.2 Advanced Configuration Mode .....	37
6.12 Prestart Installation Check .....	37
6.13 Warranty Registration .....	37
Appendix A Abbreviations .....	A-1

# Safety Precautions and Instructions

**IMPORTANT SAFETY INSTRUCTIONS.** Electromechanical equipment, including generator sets, transfer switches, switchgear, and accessories, can cause bodily harm and pose life-threatening danger when improperly installed, operated, or maintained. To prevent accidents be aware of potential dangers and act safely. Read and follow all safety precautions and instructions. **SAVE THESE INSTRUCTIONS.**

This manual has several types of safety precautions and instructions: Danger, Warning, Caution, and Notice.

## DANGER

Danger indicates the presence of a hazard that **will cause severe personal injury, death, or substantial property damage.**

## WARNING

Warning indicates the presence of a hazard that **can cause severe personal injury, death, or substantial property damage.**

## CAUTION

Caution indicates the presence of a hazard that **will or can cause minor personal injury or property damage.**

## NOTICE

Notice communicates installation, operation, or maintenance information that is safety related but not hazard related.

Safety decals affixed to the equipment in prominent places alert the operator or service technician to potential hazards and explain how to act safely. The decals are shown throughout this publication to improve operator recognition. Replace missing or damaged decals.

## Accidental Starting

### WARNING

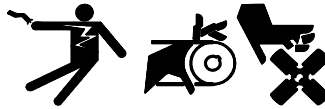

#### **Accidental starting. Can cause severe injury or death.**

Disconnect the battery cables before working on the generator set. Remove the negative (-) lead first when disconnecting the battery. Reconnect the negative (-) lead last when reconnecting the battery.

**Disabling the generator set. Accidental starting can cause severe injury or death.** Before working on the generator set or connected equipment, disable the generator set as follows: (1) Move the generator set master switch to the OFF position. (2) Disconnect the power to the battery charger. (3) Remove the battery cables, negative (-) lead first. Reconnect the negative (-) lead last when reconnecting the battery. Follow these precautions to prevent starting of the generator set by an automatic transfer switch, remote start/stop switch, or engine start command from a remote computer.

## Battery

### WARNING



#### **Sulfuric acid in batteries. Can cause severe injury or death.**

Wear protective goggles and clothing. Battery acid may cause blindness and burn skin.

### WARNING



#### **Explosion. Can cause severe injury or death. Relays in the battery charger cause arcs or sparks.**

Locate the battery in a well-ventilated area. Isolate the battery charger from explosive fumes.



**Battery electrolyte is a diluted sulfuric acid. Battery acid can cause severe injury or death.** Battery acid can cause blindness and burn skin. Always wear splashproof safety goggles, rubber gloves, and boots when servicing the battery. Do not open a sealed battery or mutilate the battery case. If battery acid splashes in the eyes or on the skin, immediately flush the affected area for 15 minutes with large quantities of clean water. Seek immediate medical aid in the case of eye contact. Never add acid to a battery after placing the battery in service, as this may result in hazardous spattering of battery acid.

**Battery acid cleanup. Battery acid can cause severe injury or death.** Battery acid is electrically conductive and corrosive. Add 500 g (1 lb.) of bicarbonate of soda (baking soda) to a container with 4 L (1 gal.) of water and mix the neutralizing solution. Pour the neutralizing solution on the spilled battery acid and continue to add the neutralizing solution to the spilled battery acid until all evidence of a chemical reaction (foaming) has ceased. Flush the resulting liquid with water and dry the area.

**Battery gases. Explosion can cause severe injury or death.** Battery gases can cause an explosion. Do not smoke or permit flames or sparks to occur near a battery at any time, particularly when it is charging. Do not dispose of a battery in a fire. To prevent burns and sparks that could cause an explosion, avoid touching the battery terminals with tools or other metal objects. Remove all jewelry before servicing the equipment. Discharge static electricity from your body before touching batteries by first touching a grounded metal surface away from the battery. To avoid sparks, do not disturb the battery charger connections while the battery is charging. Always turn the battery charger off before disconnecting the battery connections. Ventilate the compartments containing batteries to prevent accumulation of explosive gases.

**Battery short circuits. Explosion can cause severe injury or death.** Short circuits can cause bodily injury and/or equipment damage. Disconnect the battery before generator set installation or maintenance. Remove all jewelry before servicing the equipment. Use tools with insulated handles. Remove the negative (-) lead first when disconnecting the battery. Reconnect the negative (-) lead last when reconnecting the battery. Never connect the negative (-) battery cable to the positive (+) connection terminal of the starter solenoid. Do not test the battery condition by shorting the terminals together.

## Engine Backfire/Flash Fire



 <b>WARNING</b>

<p><b>Fire.</b>  <b>Can cause severe injury or death.</b></p> <p>Do not smoke or permit flames or sparks near fuels or the fuel system.</p>

**Servicing the air cleaner. A sudden backfire can cause severe injury or death.** Do not operate the generator set with the air cleaner removed.

**Servicing the fuel system. A flash fire can cause severe injury or death.** Do not smoke or permit flames or sparks near the carburetor, fuel line, fuel filter, fuel pump, or other potential sources of spilled fuels or fuel vapors. Catch fuels in an approved container when removing the fuel line or carburetor.

**Combustible materials. A fire can cause severe injury or death.** Generator set engine fuels and fuel vapors are flammable and explosive. Handle these materials carefully to minimize the risk of fire or explosion. Equip the compartment or nearby area with a fully charged fire extinguisher. Select a fire extinguisher rated ABC or BC for electrical fires or as recommended by the local fire code or an authorized agency. Train all personnel on fire extinguisher operation and fire prevention procedures.

## Exhaust System

 <b>WARNING</b>

<p><b>Carbon monoxide.</b>  <b>Can cause severe nausea, fainting, or death.</b></p> <p>The exhaust system must be leakproof and routinely inspected.</p>

**Generator set operation. Carbon monoxide can cause severe nausea, fainting, or death.** Carbon monoxide is an odorless, colorless, tasteless, nonirritating gas that can cause death if inhaled for even a short time. Avoid breathing exhaust fumes when working on or near the generator set. Never operate the generator set inside a building. Never operate the generator set where exhaust gas could seep inside or be drawn into a potentially occupied building through windows, air intake vents, or other openings.

**Carbon monoxide symptoms. Carbon monoxide can cause severe nausea, fainting, or death.** Carbon monoxide is a poisonous gas present in exhaust gases. Carbon monoxide poisoning symptoms include but are not limited to the following:

- Light-headedness, dizziness
- Physical fatigue, weakness in joints and muscles
- Sleepiness, mental fatigue, inability to concentrate or speak clearly, blurred vision
- Stomachache, vomiting, nausea

If experiencing any of these symptoms and carbon monoxide poisoning is possible, seek fresh air immediately and remain active. Do not sit, lie down, or fall asleep. Alert others to the possibility of carbon monoxide poisoning. Seek medical attention if the condition of affected persons does not improve within minutes of breathing fresh air.

## Fuel System

### ⚠ WARNING

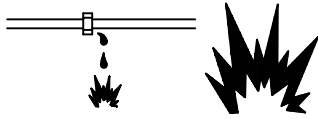

**Explosive fuel vapors.**  
**Can cause severe injury or death.**

Use extreme care when handling, storing, and using fuels.

**The fuel system. Explosive fuel vapors can cause severe injury or death.** Vaporized fuels are highly explosive. Use extreme care when handling and storing fuels. Store fuels in a well-ventilated area away from spark-producing equipment and out of the reach of children. Never add fuel to the tank while the engine is running because spilled fuel may ignite on contact with hot parts or from sparks. Do not smoke or permit flames or sparks to occur near sources of spilled fuel or fuel vapors. Keep the fuel lines and connections tight and in good condition. Do not replace flexible fuel lines with rigid lines. Use flexible sections to avoid fuel line breakage caused by vibration. Do not operate the generator set in the presence of fuel leaks, fuel accumulation, or sparks. Repair fuel systems before resuming generator set operation.

**Gas fuel leaks. Explosive fuel vapors can cause severe injury or death.** Fuel leakage can cause an explosion. Check the LP vapor gas or natural gas fuel system for leakage by using a soap and water solution with the fuel system test pressurized to 6-8 ounces per square inch (10-14 inches water column). Do not use a soap solution containing either ammonia or chlorine because both prevent bubble formation. A successful test depends on the ability of the solution to bubble.

## Hazardous Noise

### ⚠ CAUTION



**Hazardous noise.**  
**Can cause hearing loss.**

Never operate the generator set without a muffler or with a faulty exhaust system.

**Engine noise. Hazardous noise can cause hearing loss.** Generator sets not equipped with sound enclosures can produce noise levels greater than 105 dBA. Prolonged exposure to noise levels greater than 85 dBA can cause permanent hearing loss. Wear hearing protection when near an operating generator set.

## Hazardous Voltage/ Electrical Shock

### ⚠ DANGER



**Hazardous voltage.**  
**Will cause severe injury or death.**

Disconnect all power sources before opening the enclosure.

### ⚠ WARNING

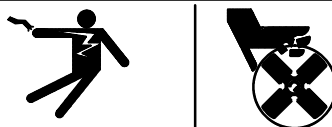

**Hazardous voltage. Moving rotor.**  
**Can cause severe injury or death.**

Operate the generator set only when all guards and electrical enclosures are in place.

### ⚠ WARNING



**Hazardous voltage.**  
**Backfeed to the utility system can cause property damage, severe injury, or death.**

If the generator set is used for standby power, install an automatic transfer switch to prevent inadvertent interconnection of standby and normal sources of supply.

### ⚠ CAUTION

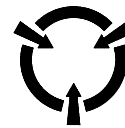

**Welding the generator set.**  
**Can cause severe electrical equipment damage.**

Never weld components of the generator set without first disconnecting the battery, controller wiring harness, and engine electronic control module (ECM).

**Grounding electrical equipment. Hazardous voltage can cause severe injury or death.** Electrocutation is possible whenever electricity is present. Open the main circuit breakers of all power sources before servicing the equipment. Configure the installation to electrically ground the generator set, transfer switch, and related equipment and electrical circuits to comply with applicable codes and standards. Never contact electrical leads or appliances when standing in water or on wet ground because these conditions increase the risk of electrocution.

**Welding on the generator set. Can cause severe electrical equipment damage.** Before welding on the generator set perform the following steps: (1) Remove the battery cables, negative (-) lead first. (2) Disconnect all engine electronic control module (ECM) connectors. (3) Disconnect all generator set controller and voltage regulator circuit board connectors. (4) Disconnect the engine battery-charging alternator connections. (5) Attach the weld ground connection close to the weld location.

**Installing the battery charger. Hazardous voltage can cause severe injury or death.** An ungrounded battery charger may cause electrical shock. Connect the battery charger enclosure to the ground of a permanent wiring system. As an alternative, install an equipment grounding conductor with circuit conductors and connect it to the equipment grounding terminal or the lead on the battery charger. Install the battery charger as prescribed in the equipment manual. Install the battery charger in compliance with local codes and ordinances.

**Connecting the battery and the battery charger. Hazardous voltage can cause severe injury or death.** Reconnect the battery correctly, positive to positive and negative to negative, to avoid electrical shock and damage to the battery charger and battery(ies). Have a qualified electrician install the battery(ies).

**Short circuits. Hazardous voltage/current can cause severe injury or death.** Short circuits can cause bodily injury and/or equipment damage. Do not contact electrical connections with tools or jewelry while making adjustments or repairs. Remove all jewelry before servicing the equipment.

**Electrical backfeed to the utility. Hazardous backfeed voltage can cause severe injury or death.** Install a transfer switch in standby power installations to prevent the connection of standby and other sources of power. Electrical backfeed into a utility electrical system can cause severe injury or death to utility personnel working on power lines.

## Heavy Equipment

<b>⚠ WARNING</b>

<p><b>Unbalanced weight. Improper lifting can cause severe injury or death and equipment damage.</b></p> <p>Do not use lifting eyes. Lift the generator set using lifting bars inserted through the lifting holes on the skid.</p>

## Hot Parts



<b>⚠ WARNING</b>

<p><b>Hot engine and exhaust system. Can cause severe injury or death.</b></p> <p>Do not work on the generator set until it cools.</p>

**Servicing the generator. Hot parts can cause severe injury or death.** Avoid touching the generator set field or exciter armature. When shorted, the generator set field and exciter armature become hot enough to cause severe burns.

**Servicing the exhaust system. Hot parts can cause severe injury or death.** Do not touch hot engine parts. The engine and exhaust system components become extremely hot during operation.

**Servicing the engine heater. Hot parts can cause minor personal injury or property damage.** Install the heater before connecting it to power. Operating the heater before installation can cause burns and component damage. Disconnect power to the heater and allow it to cool before servicing the heater or nearby parts.

## Moving Parts

<b>⚠ WARNING</b>	
	
<p><b>Hazardous voltage. Moving rotor. Can cause severe injury or death.</b></p> <p>Operate the generator set only when all guards and electrical enclosures are in place.</p>	

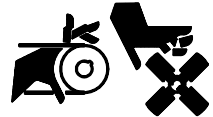
<b>⚠ WARNING</b>

<p><b>Rotating parts. Can cause severe injury or death.</b></p> <p>Operate the generator set only when all guards, screens, and covers are in place.</p>

<b>⚠ WARNING</b>

<p><b>Airborne particles. Can cause severe injury or blindness.</b></p> <p>Wear protective goggles and clothing when using power tools, hand tools, or compressed air.</p>

**Tightening the hardware. Flying projectiles can cause severe injury or death.** Loose hardware can cause the hardware or pulley to release from the generator set engine and can cause personal injury. Retorque all crankshaft and rotor hardware after servicing. Do not loosen the crankshaft hardware or rotor throbolt when making adjustments or servicing the generator set. Rotate the crankshaft manually in a clockwise direction only. Turning the crankshaft bolt or rotor throbolt counterclockwise can loosen the hardware.

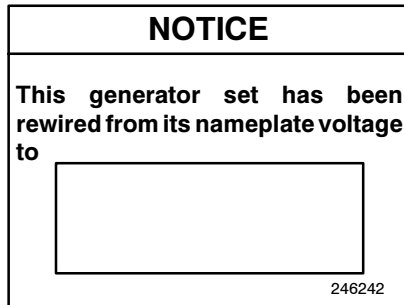
**Servicing the generator set when it is operating. Exposed moving parts can cause severe injury or death.** Keep hands, feet, hair, clothing, and test leads away from the belts and pulleys when the generator set is running. Replace guards, screens, and covers before operating the generator set.

## Notice



## NOTICE

**Voltage reconnection.** Affix a notice to the generator set after reconnecting the set to a voltage different from the voltage on the nameplate. Order voltage reconnection decal 246242 from an authorized service distributor/dealer.

## NOTICE

**Hardware damage.** The engine and generator set may use both American Standard and metric hardware. Use the correct size tools to prevent rounding of the bolt heads and nuts.

## NOTICE

**When replacing hardware, do not substitute with inferior grade hardware.** Screws and nuts are available in different hardness ratings. To indicate hardness, American Standard hardware uses a series of markings, and metric hardware uses a numeric system. Check the markings on the bolt heads and nuts for identification.

## NOTICE

**Canadian installations only.** For standby service connect the output of the generator set to a suitably rated transfer switch in accordance with Canadian Electrical Code, Part 1.

## NOTICE

**Electrostatic discharge damage.** Electrostatic discharge (ESD) damages electronic circuit boards. Prevent electrostatic discharge damage by wearing an approved grounding wrist strap when handling electronic circuit boards or integrated circuits. An approved grounding wrist strap provides a high resistance (about 1 megohm), *not a direct short*, to ground.

# Notes

This manual provides operation and installation instructions for model 8.5RES and 12RES generator sets equipped with the Kohler® Advanced Digital Control (ADC 2100).

Information in this publication represents data available at the time of print. The manufacturer may provide this manual for models not listed on the front cover. Kohler Co. reserves the right to change this publication and the products represented without notice and without any obligation or liability whatsoever.

Read this manual and carefully follow all procedures and safety precautions to ensure proper equipment operation and to avoid bodily injury. Read and follow the Safety Precautions and Instructions section at the beginning of this manual. Keep this manual with the equipment for future reference.

The generator set is approved for use in stationary applications in locations served by a reliable utility power source.

The equipment service requirements are very important to safe and efficient operation. Inspect the parts often and perform required service at the prescribed intervals. Obtain service from an authorized service distributor/dealer to keep equipment in top condition.

## Nameplate

The following illustration shows a typical generator set nameplate. Copy the model, serial, and specification numbers from the nameplate into the spaces provided in the product information section on the inside front cover of this manual. See Section 1.5, Service Views, for the nameplate location.

<b>KOHLER</b> KOHLER CO. KOHLER WI. USA						
MODEL:			SERIAL:			
SPEC:						
SERVICE DUTY:						
HZ:    RPM:						
VOLTAGE	AMPS	PHASE	KW	KVA	P.F.	
GEN. MODEL:				BATT. V		
INSULATION: NEMA CLASS						
KW VARIES WITH BTU CONTENT OF FUEL						

## EPA and California Emission Certification

An engine or generator set with the following identification labels is certified to meet Small Off-Road Engine emission standards for EPA/CARB. All model 8.5RES and 12RES generator sets with multi-fuel systems are emission-certified.

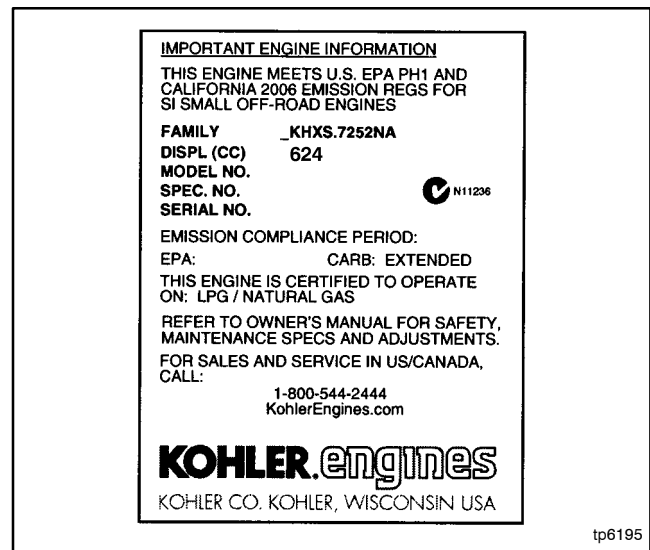

Figure 1 Emissions Label, 8.5RES Engine (CH20)

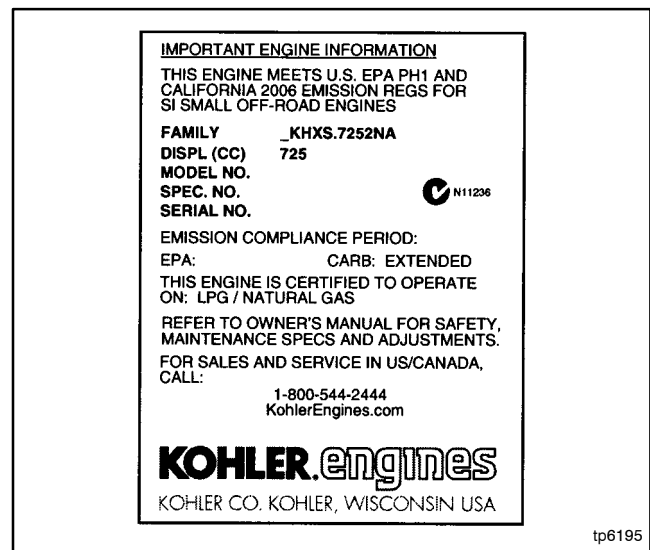
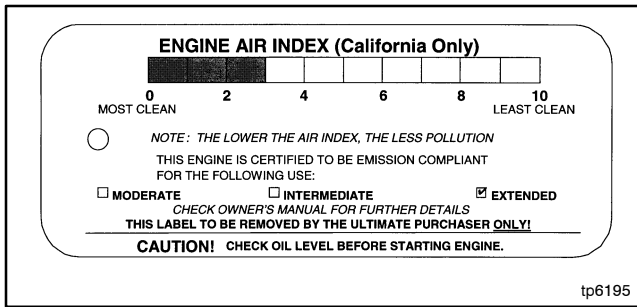

Figure 2 Emissions Label, 12 RES Engine (CH740)



**Figure 3** Air Index Label, 8.5/12RES

This engine/generator is certified to operate using natural gas or propane fuel.

The Emission Compliance Period referred to on the Emission Control or Air Index label indicates the number

of operating hours for which the engine has been shown to meet CARB emission requirements. The following table provides the engine compliance period (in hours) associated with the category descriptor found on the certification label.

Emission Compliance Period (hours)			
CARB	Moderate, 125	Intermediate, 250	Extended, 500

Refer to the certification label for engine displacement.

The exhaust emission control system for the 8.5RES (CH20) and 12RES (CH740) is EM.

## Service Assistance

For professional advice on generator power requirements and conscientious service, please contact your nearest Kohler distributor or dealer.

- Consult the Yellow Pages under the heading Generators—Electric
- Visit the Kohler Power Systems website at [KohlerPowerSystems.com](http://KohlerPowerSystems.com)
- Look at the labels and stickers on your Kohler product or review the appropriate literature or documents included with the product
- Call toll free in the US and Canada 1-800-544-2444
- Outside the US and Canada, call the nearest regional office

### Headquarters Europe, Middle East, Africa (EMEA)

Kohler Power Systems  
 ZI Senia 122  
 12, rue des Hauts Flouviars  
 94517 Thiais Cedex  
 France  
 Phone: (33) 1 41 735500  
 Fax: (33) 1 41 735501

### Asia Pacific

Power Systems Asia Pacific Regional Office  
 Singapore, Republic of Singapore  
 Phone: (65) 264-6422  
 Fax: (65) 264-6455

### China

North China Regional Office, Beijing  
 Phone: (86) 10 6518 7950  
 (86) 10 6518 7951  
 (86) 10 6518 7952  
 Fax: (86) 10 6518 7955

East China Regional Office, Shanghai  
 Phone: (86) 21 6288 0500  
 Fax: (86) 21 6288 0550

### India, Bangladesh, Sri Lanka

India Regional Office  
 Bangalore, India  
 Phone: (91) 80 3366208  
 (91) 80 3366231  
 Fax: (91) 80 3315972

### Japan, Korea

North Asia Regional Office  
 Tokyo, Japan  
 Phone: (813) 3440-4515  
 Fax: (813) 3440-2727

### Latin America

Latin America Regional Office  
 Lakeland, Florida, USA  
 Phone: (863) 619-7568  
 Fax: (863) 701-7131

# Section 1 Specifications and Features

---

## 1.1 Specifications

The generator set specification sheets provide specific generator and engine information. Refer to the spec sheet for data not supplied in this manual. Consult the generator set service manual, engine operation manual, and engine service manual for additional specifications. Obtain copies of the latest spec sheets, manuals, diagrams, and drawings from your local distributor/dealer.

## 1.2 Generator

The generator uses Kohler's unique PowerBoost™ voltage regulation system, which provides instant response to load changes.

PowerBoost™ ensures reliable motor starting and consistent voltage levels. PowerBoost™ utilizes a voltage excitation system that employs a winding independent of the main output windings to provide excitation voltage.

## 1.3 Engine

The generator set has a four-cycle, twin cylinder, air-cooled Kohler® engine. The engine operates on clean-burning natural gas or propane (LP) vapor. Engine features include:

- Efficient overhead valve design and full pressure lubrication for maximum power, torque, and reliability under all operating conditions.
- Dependable, maintenance-free electronic ignition.
- Precision-formulated cast iron construction of parts subjected to the most wear and tear.
- Field-convertible multi-fuel systems that allow fuel changeover from natural gas to LP vapor (and vice-versa) while maintaining CARB emission certification.
- Digital spark-advance module (DSAM) optimizes ignition timing for the selected fuel (12RES).

## 1.4 Advanced Digital Control

The generator set is equipped with the Kohler® Advanced Digital Control (ADC 2100). Controller features include the following:

- Compact controller
- Integrally mounted to the generator set
- LED display:
  - Runtime hours
  - Crank cycle status
  - Diagnostics
- LED display communicates faults:
  - Auxiliary fault
  - High battery voltage
  - High engine temperature
  - Low battery voltage
  - Low oil pressure
  - Overcrank safety
  - Overspeed
  - Overfrequency
  - Overvoltage
  - Underfrequency
  - Undervoltage
- Membrane keypad for configuration and adjustment
  - Password-protected user access to menus
  - Voltage, gain, and speed adjustment
  - System configuration (system voltage, phase, and frequency settings, battery voltage, and generator set model)
- Master control switch: Run/Off-Reset/Auto
- Remote two-wire start/stop capability
- Superior electronics protection from corrosion and vibration
  - Potted electronics
  - Sealed connections
- Digital isochronous governor to maintain steady-state speed at all loads
- Digital voltage regulation:  $\pm 1.5\%$  RMS no-load to full-load
- Automatic start for programmed cranking cycle

## 1.5 Service Views

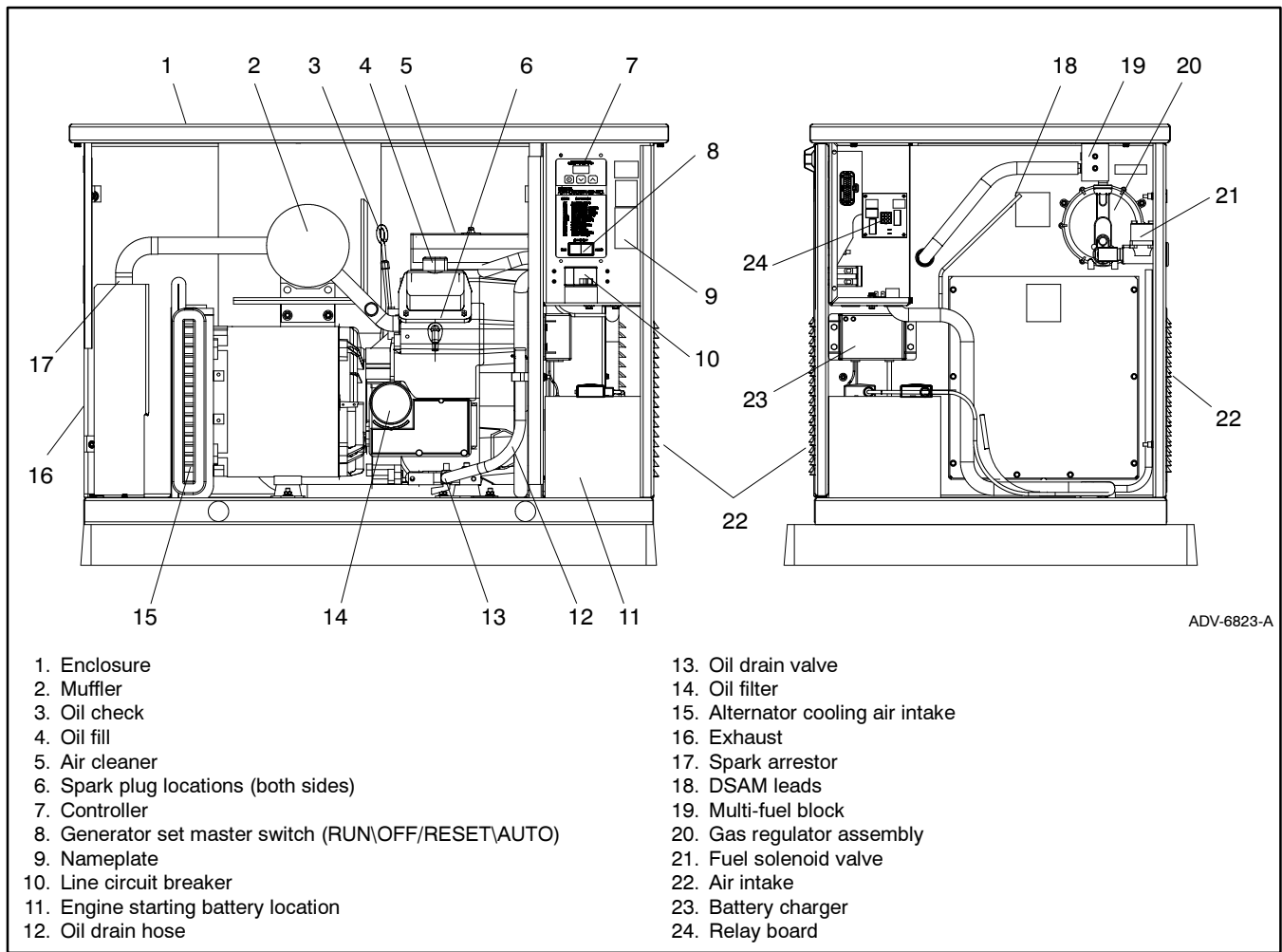

**Figure 1-1** Generator Set Service View

## 2.1 Prestart Checklist

To ensure continued satisfactory operation, perform the following checks or inspections before or at each startup, as designated, and at the intervals specified in the service schedule. In addition, some checks require verification after the unit starts.

**Air Cleaner.** Check for a clean and installed air cleaner element to prevent unfiltered air from entering the engine.

**Air Inlets.** Check for clean and unobstructed air inlets.

**Battery.** Check for tight battery connections. Consult the battery manufacturer's instructions regarding battery care and maintenance.

**Exhaust System.** Check for exhaust leaks and blockages. Check the muffler and piping condition and check for tight exhaust system connections.

Inspect the exhaust system components (exhaust manifold, exhaust line, flexible exhaust, clamps, muffler, and outlet pipe) for cracks, leaks, and corrosion.

- Check for corroded or broken metal parts and replace them as needed.
- Check for loose, corroded, or missing clamps and hangers. Tighten or replace the exhaust clamps and/or hangers as needed.
- Check that the exhaust outlet is unobstructed.
- Visually inspect for exhaust leaks (*blowby*). Check for carbon or soot residue on exhaust components. Carbon and soot residue indicates an exhaust leak. Seal leaks as needed.

**Oil Level.** Maintain the oil level at or near, not over, the full mark on the dipstick.

**Operating Area.** Check for obstructions that could block the flow of cooling air. Keep the air intake area clean. Do not leave rags, tools, or debris on or near the generator set.

x.op:001:002

## 2.2 Exercising the Generator Set

Operate the generator set under load once each week for one hour. If the generator set does not have a programmed exercise mode or an automatic transfer switch (ATS) with an exercise option, exercise the unit in the presence of an operator.

During the exercise period apply a minimum of 35% load based on the nameplate standby rating.

The operator should perform all of the prestart checks before starting the exercise procedure. Start the generator set according to the starting procedure in the controller section of this manual. While the generator set is operating, listen for a smooth-running engine and visually inspect the generator set for fluid or exhaust leaks. Check the air inlets and outlets and remove any items restricting the air flow.

## 2.3 Generator Set Operation

Figure 2-1 illustrates the user interface on the Advanced Digital Control (ADC 2100) generator set controller.

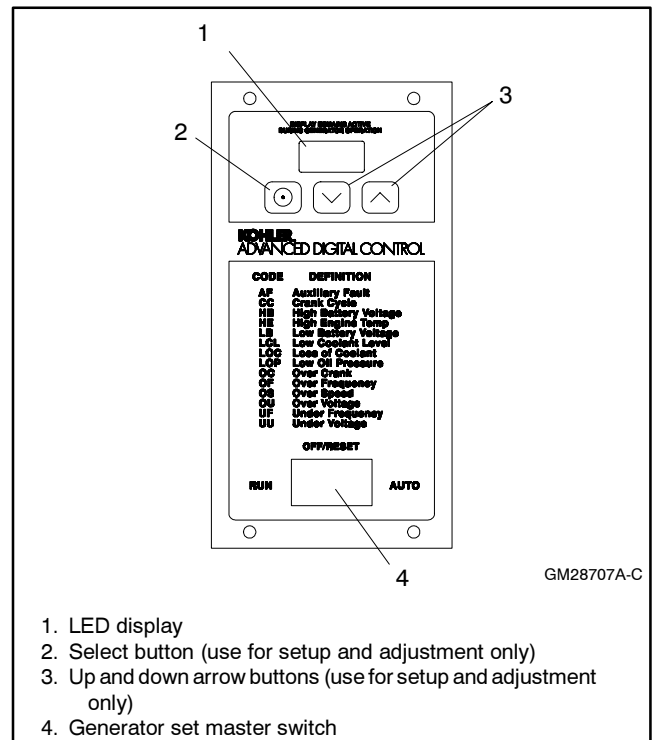

Figure 2-1 ADC 2100 Controller User Interface

### 2.3.1 Controls and Indicators

Figure 2-2 describes the controls and indicators located on the generator set controller.

The LED display indicates generator set status as shown in Figure 2-2. The display is activated by a start or run command and remains active until the generator set master switch is moved to the OFF/RESET position or power to the controller is removed. If the factory-installed continuous power mode jumper has been disconnected, the LED display turns off 48 hours after generator set shutdown. See Section 2.3.6.

The buttons on the controller keypad are used only for system configuration and adjustment. The controller is factory-set and should not require configuration or adjustment under normal operating conditions. Contact an authorized distributor/dealer or service technician if adjustments are required.

### 2.3.2 Starting the Generator Set

The following procedures describe the actions required to start the generator set.

The controller attempts to start the generator set three times (three crank cycles, 15 seconds crank and 15 seconds off). If the generator set does not start in three attempts, the system shuts down on an overcrank fault.

#### Local Starting

Move the generator set master switch to the RUN position to immediately start the generator set.

#### Auto (Automatic) Starting

Move the generator set master switch to the AUTO position to allow startup by the ATS or the remote

start/stop switch. (A remote start/stop switch can be connected to controller leads 3 and 4. See the wiring diagrams in Section 5).

### 2.3.3 Stopping the Generator Set

The following procedures describe the actions required to stop the generator set.

#### Local Stopping

1. Run the generator set at no load for at least 2 minutes to ensure adequate engine cooldown.
2. Move the generator set master switch to the OFF/RESET position. The engine stops.

#### Automatic Stopping

With the generator set master switch in the AUTO position and an automatic transfer switch (ATS) or other automatic device connected to controller leads 3 and 4:

1. The ATS or other device disconnects the load from the generator set.
2. If the ATS is equipped with an engine cooldown time delay, the generator set continues to run for a preset engine cooldown time.
 

**Note:** There is no engine cooldown time delay on the ADC controller.
3. The ATS or other device opens the connection between controller leads 3 and 4. The generator set shuts down.

Control or Indicator	Item	Description
LED display	Runtime hours	Displays total generator set runtime hours while the generator set is running.
	Crank indication	Displays CC_1, CC_2, or CC_3 to indicate the first, second or third attempt to start the engine. The last digit flashes during the crank cycle rest periods.
	Fault codes	Flashes a 2- or 3-letter fault code to indicate various fault conditions. See Section 2.3.4.
	Software version number	See TP-6196, Generator Set Service Manual.
Keypad	Select and arrow buttons	The keypad is used for controller setup and adjustment only. Have setup and adjustments performed only by an authorized distributor/dealer. The setup and adjustment functions are password-protected.
Generator set master switch	Three-position switch	Switch functions as the generator set operation and controller reset switch.

**Figure 2-2** ADC 2100 Controls and Indicators

### 2.3.4 Fault Shutdowns

The generator set shuts down automatically under the fault conditions listed in Figure 2-3 and the controller displays a fault code. The generator set cannot be restarted until the fault condition is corrected and the controller is reset. See Section 2.3.5 to reset the controller after a fault shutdown. The controller resets automatically after a battery voltage fault condition is corrected.

The shutdown switches on the generator set automatically reset when the problem is corrected. The high engine temperature switch automatically resets when the generator set cools. However, the fault does not clear until the controller is reset.

The controller displays a fault code but the generator set does not shut down under the conditions shown in Figure 2-4.

Code	Fault	Description	Check
AF	Auxiliary fault input shutdown	Input from a customer-supplied switch that closes when the fault is active. The generator set shuts down and will not start when the fault is active (input is grounded).	Check the cause of the auxiliary fault.
HE	High engine temperature shutdown	Shutdown occurs if the engine coolant temperature exceeds the maximum temperature for more than 5 seconds. This protective becomes active after the engine reaches the crank disconnect speed.	Check for blocked air inlets and exhaust outlets.
LOP	Low oil pressure shutdown	Shutdown occurs if a low oil pressure condition exists 7 seconds after the engine has reached crank disconnect speed. <b>Note:</b> The low oil pressure shutdown does not protect against low oil level. Check the oil level at the engine.	Check for leaks in the lubrication system. Check the oil level and add oil if the level is low.
OC	Overcrank shutdown	Shutdown occurs after 3 unsuccessful starting attempts. The crank cycle is set for three starting attempts of 15 seconds cranking and 15 seconds rest.  The generator set also shuts down after 1 crank attempt if no speed signal is sensed. Shuts down 1 second after the fault is detected.	Check the fuel supply, spark plug, and battery. Check for loose connections. Contact an authorized distributor/dealer for service if problem continues.
OF	Overfrequency shutdown	Shutdown occurs when the governed frequency exceeds 110% of the system's frequency setpoint for more than 1 second. This protective becomes active 30 seconds after engine start.	Contact an authorized distributor/dealer for service if problem continues.
OS	Overspeed shutdown	Shutdown occurs if the engine speed exceeds 115% of the normal running speed for more than 1 second.	Contact an authorized distributor/dealer for service if problem continues.
OU	Overvoltage shutdown	Shutdown occurs if the voltage exceeds 120% of the voltage regulator setpoint for more than 1 second.	Contact an authorized distributor/dealer for service if problem continues.
UF	Underfrequency shutdown	Shutdown occurs when the governed frequency falls 1 Hz below the system's frequency setpoint for more than 1 second.	Reduce the load and restart the generator set. Contact an authorized distributor/dealer for service if problem continues.
UU	Undervoltage shutdown	Shutdown occurs if the voltage falls below 80% of the voltage regulator setpoint for more than 1 second. This protective becomes active 30 seconds after engine start.	Reduce the load and restart the generator set. Contact an authorized distributor/dealer for service if problem continues.

Figure 2-3 ADC Fault Shutdown Codes

Code	Fault	Description	Check
HB	High battery voltage warning	Fault code is displayed if the engine starting battery voltage rises above 16 VDC for a 12 VDC system or above 30 VDC for a 24 VDC system for more than 10 seconds when the engine is not running. This fault condition does not inhibit engine starting.  The fault condition clears when the battery voltage returns to a voltage within the limits for more than 10 seconds.	Check the battery rating and condition. Check the battery charger operation.
LB	Low battery voltage warning	Fault code is displayed if the engine starting battery voltage falls below 8 VDC for a 12 VDC system or below 16 VDC for a 24 VDC system for more than 10 seconds when the engine is not running. This fault condition does not inhibit engine starting.  The fault condition clears when the battery voltage returns to a voltage within the limits for more than 10 seconds.	Check the battery rating and condition. Check the battery charger operation. Charge or replace the battery.

Figure 2-4 ADC Fault Warning Codes

### 2.3.5 Resetting the Controller after a Fault Shutdown

Always identify and correct the cause of a fault shutdown before resetting the controller. Use the following procedure to reset the generator set controller after a fault shutdown.

1. Move the generator set master switch to OFF/RESET.
2. Disconnect the generator set from the load using the line circuit breaker or ATS. See the safety precautions at the beginning of this section before proceeding.
3. Identify and correct the cause of the fault shutdown. See the safety precautions at the beginning of this section before proceeding. Refer to Section 4, Troubleshooting.
4. Start the generator set by moving the generator set master switch to RUN. Test operate the generator set to verify that the cause of the shutdown has been corrected.
5. Move the generator set master switch to OFF/RESET.
6. Reconnect the generator set to the load using the line circuit breaker or ATS.

7. Move the generator set master switch to the AUTO position for startup by remote transfer switch or remote start/stop switch.

**Note:** The controller's LED display remains off until an engine start command is received.

Opening and closing a remote start/stop contact also resets the controller.

### 2.3.6 Continuous Power Mode

The controller is powered by the generator set engine starting battery. A jumper on the back of the controller maintains power to the controller at all times. Controllers are shipped with the jumper connected.

**Note:** The 8.5 and 12 RES generator sets are equipped with factory-installed battery chargers to prevent battery discharge.

Disconnecting the jumper allows the controller to power down automatically 48 hours after the generator set shuts down if the generator set master switch is in the AUTO position. A remote start signal (from a transfer switch or a remote start/stop switch connected to controller leads 3 and 4) or moving the generator set master switch to the RUN position turns the controller back on.

See Section 6.9.3 for instructions to disconnect the jumper.

## 2.4 Circuit Protection

If the generator set circuit breaker trips or the fuses blow repeatedly, see Section 4, Troubleshooting, for possible causes.

### 2.4.1 Line Circuit Breaker

A line circuit breaker interrupts the generator output in the event of a fault in the wiring between the generator and the load. The line circuit breaker location is shown in Figure 1-1. See Figure 2-5 for the circuit breaker ratings. If the circuit breaker trips, reduce the load and switch the breaker back to the ON position. With the breaker in the OFF position the generator set runs but the generator output is disconnected from the load.

Model	Circuit Breaker Rating, Amps
8.5RES	40
12RES	50

**Figure 2-5** Line Circuit Breakers

### 2.4.2 Fuses

The engine harness contains two 10-amp and one 20-amp inline fuses. See Figure 2-6. Another 10-amp fuse protects the battery charger.

Always identify and correct the cause of a blown fuse before restarting the generator set. Refer to Section 4, Troubleshooting, for conditions that may indicate a blown fuse. Replace blown fuses with identical replacement parts.

Fuse	Label	Part Number	Location
Auxiliary Winding	F1	292937	Lead 55
Relay Interface Board	F2	223316	Lead PF2
Controller	F3	358337	Lead PF1
Battery Charger	—	AGS 10	Battery charger DC lead. See Section 2.5.

**Figure 2-6** Fuses

## 2.5 Battery Charger

The generator set is equipped with a 6-amp float/equalize battery charger to maintain the engine starting battery. The charger's power cord must be connected to a 120 VAC power source. Figure 2-7 illustrates the battery charger.

The battery charger uses an AGS 10 inline fuse. The fuse is located in the battery lead. See Figure 2-7.

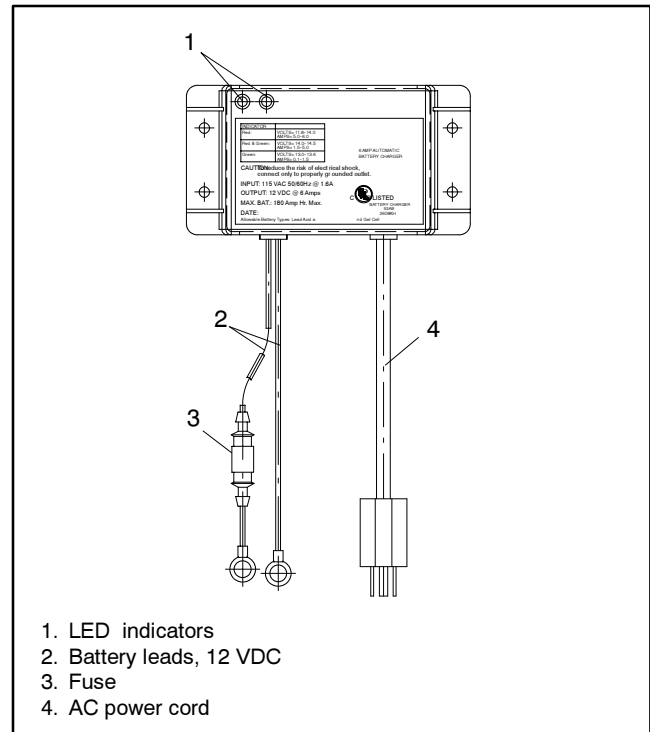

**Figure 2-7** 6-Amp Float/Equalize Battery Charger

## 2.5.1 Battery Charger Operation

Figure 2-8 illustrates the three-stage charging method. Red and green LEDs indicate charger operation. The chart in Figure 2-9 describes the LED indicator operation during each stage of the charging process.

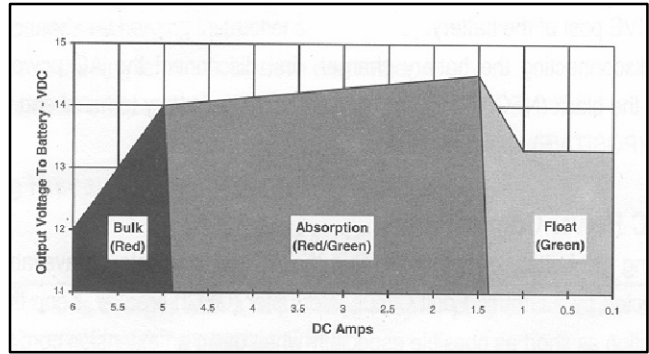
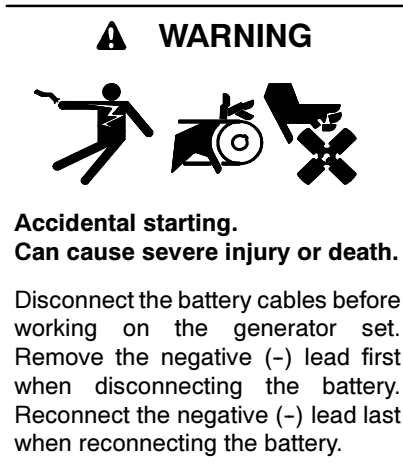

**Figure 2-8** Charging Method

Display	Operating Condition
Red ON Green OFF	When the red LED is on, it indicates the battery is discharged and the battery charger is recharging at the BULK rate (stage 1). This charging rate is 6 amps. While the red LED is on, the voltage measured (with the battery charger on) will be 11.8-14 volts. If the red LED stays on for more than 24 hours, refer to Section 4.5 in this manual.
Red ON Green ON	When both the green and the red LEDs are on, the battery charger is charging at an ABSORPTION rate of between 1.5 and 5 amps (stage 2). This mode of charging gradually tops off your battery, and reduces harmful sulfating. While both LEDs are on, the voltage measured (with the battery charger on) should be approximately 14.0-14.5 VDC. If both LEDs stay on longer than 24 hours, refer to Section 4.5 in this manual.
Red OFF Green ON	When the green LED is on, the battery charger is charging at a FLOAT or MAINTENANCE rate of less than 1.5 amps (stage 3). Your battery is now 90% charged and ready for use. This float charging current will gradually decrease to as low as 0.1 amps as the battery reaches 100% charge. It will now be kept at full charge without overcharging. If the green LED stays on when your battery is known to be low, refer to Section 4.5 in this manual.

**Figure 2-9** Battery Charger LED Indicator Functions

## Section 3 Scheduled Maintenance



**Disabling the generator set. Accidental starting can cause severe injury or death.** Before working on the generator set or connected equipment, disable the generator set as follows: (1) Move the generator set master switch to the OFF position. (2) Disconnect the power to the battery charger. (3) Remove the battery cables, negative (-) lead first. Reconnect the negative (-) lead last when reconnecting the battery. Follow these precautions to prevent starting of the generator set by an automatic transfer switch, remote start/stop switch, or engine start command from a remote computer.

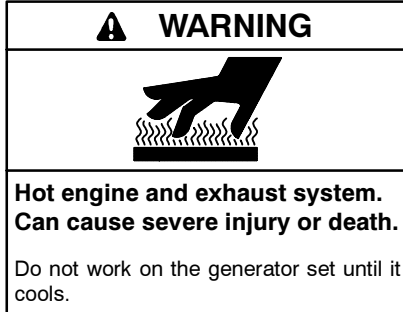

**Servicing the exhaust system. Hot parts can cause severe injury or death.** Do not touch hot engine parts. The engine and exhaust system components become extremely hot during operation.

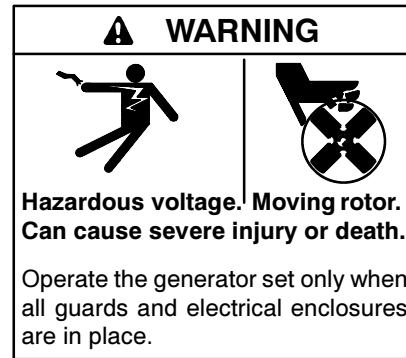

**Servicing the generator set when it is operating. Exposed moving parts can cause severe injury or death.** Keep hands, feet, hair, clothing, and test leads away from the belts and pulleys when the generator set is running. Replace guards, screens, and covers before operating the generator set.

### 3.1 Routine Maintenance

Refer to the service schedule following and the runtime hours displayed on the ADC 2100 display to schedule routine maintenance. Have an authorized distributor/dealer perform all generator set service. Perform maintenance on each item in the service schedule at the designated interval for the life of the generator set. Service units subject to extreme weather, long operating hours, or dusty or dirty conditions more frequently.

### 3.2 Service Schedule

Perform the tasks listed in the following service schedule at the designated intervals for the life of the generator set. For example, an item serviced every 100 hours of operation or 3 months must also be serviced after 200 hours or 6 months, 300 hours or 9 months and so on. Rough operation, lack of power, and excessive oil use indicate serious generator set problems. Have an authorized distributor/dealer perform all generator set service.

System Component or Procedure	See Section	Procedure					Frequency
		Visually Inspect	Check	Change	Clean	Test	
<b>Fuel</b>							
Flexible lines and connections		X		R			Quarterly
Main tank supply level			X				Weekly
Fuel piping		X					Yearly
<b>Lubrication</b> 3.3							
Oil level		X	X				8 hours or before use
Crankcase breather*		X		X			Yearly or 500 hours
Change oil				X			Yearly or 100 hours
Replace filter*				X			Yearly or 200 hours
<b>Cooling</b> 3.6							
Air ducts, louvers			X		X		Yearly
<b>Exhaust Line</b> 3.7							
Leakage		X	X				Weekly
Insulation, fire hazards		X					Yearly
Hangers and supports		X					Yearly
<b>DC Electrical System</b> 3.8							
Battery charger operation, charge rate (if equipped)		X					Monthly
Remove corrosion, clean and dry battery and rack		X			X		Yearly
Clean and tighten battery terminals		X	X				Yearly
Battery electrolyte level and specific gravity†			X				Yearly
<b>AC Electrical System</b>							
Visible wear or damage		X					Quarterly
Wire abrasions where subject to motion		X	X				Six Months
Tighten control and power wiring connections			X				Yearly
Wire-cable insulation breakdown *		X					3 Years or 500 hours
<b>Engine and Mounting</b>							
Visible wear or damage		X					Weekly
Air cleaner service	3.5			R			Yearly or 100 hours
Spark plugs	3.4			X			Yearly or 300 hours
Replace stepper motor coupling and bushing *				X			500 hours
Compartment condition		X			X		Weekly
<b>Remote Control System</b>							
Remote control						X	Monthly
Run generator set						X	Weekly
<b>Generator</b>							
Visible wear or damage	2.1	X					Quarterly
Exercise generator set	2.2					X	Weekly
Rotor and stator *		X			X		Yearly
Measure and record resistance readings of windings with insulation tester (Megger, with SCR assembly or rectifier disconnected)						X	3 Years
<b>General Condition of Equipment</b>							
Evidence of vibration, leakage, excessive noise, temperature, or deterioration		X	X		X		Weekly
Interior of sound enclosure		X			X		Quarterly
* Contact your local distributor/dealer for parts or service.		X Action					
† Not necessary for maintenance-free batteries.		R Replace as necessary					

**Figure 3-1** Service Schedule

### 3.3 Lubrication System

See Section 3.2, Service Schedule, for oil change and oil filter replacement intervals. See Section 1.5, Service Views, for the oil drain, oil check, oil fill, and oil filter locations.

For extended operation, check the oil level every 8 hours. Maintain the oil level at or near, not over, the full mark on the dipstick.

#### 3.3.1 Low Oil Pressure Shutdown

The low oil pressure shutdown feature protects the engine against internal damage if the oil pressure drops below 24.1 kPa  $\pm$  13.8 kPa (3.5 psi  $\pm$  1.5 psi) because of oil pump failure or other malfunction. The shutdown feature does not protect against damage caused by operating with the oil level below the safe range; it is not a low oil level shutdown. Check the oil level regularly, and add oil as needed.

#### 3.3.2 Oil Check

The generator set is shipped with oil. Before operating a new generator set, check the engine oil in the crankcase. See 1.5, Service Views. Verify that the oil level is at the F mark on the dipstick. Add oil that has a viscosity appropriate for the climate. See Section 3.3.3, Engine Oil Recommendation.

Do not check the oil level when the generator set is running. Shut down the generator set and wait several minutes before checking the oil level.

#### 3.3.3 Engine Oil Recommendation

Use API (American Petroleum Institute) Service Class SG, SH, or SJ synthetic oil. Synthetic oil oxidizes and thickens less than other oils and leaves the engine intake valves and pistons cleaner. Select the viscosity based on the air temperature at the time of operation. See Figure 3-2.

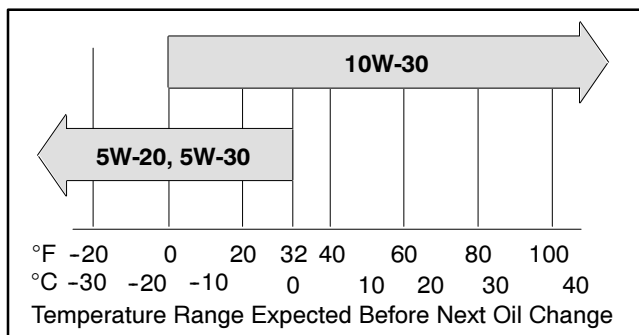

Figure 3-2 Engine Oil Selection

### 3.3.4 Oil Change Procedure

Drain the oil while it is still warm.

#### 1. Drain the oil.

- Place the generator set master switch in the OFF position.
- Disconnect the power to the battery charger.
- Disconnect the generator set engine starting battery, negative (-) lead first.
- Remove the housing side panel.
- Remove the oil drain hose from its retaining clip. Remove the cap from the oil drain hose and lower the hose into an oil collection container.
- Open the oil drain valve on the engine.
- Allow time for the engine oil to drain completely.
- Close the oil drain valve.
- Replace the cap on the oil drain hose. Replace the oil drain hose in its retaining clip.

#### 2. Replace the oil filter.

- Remove the oil filter by rotating it counterclockwise with an oil filter wrench.
- Clean the gasket sealing surface of the oil filter adapter.
- Apply a light coat of clean oil to the rubber seal of the new oil filter.
- Install the new oil filter following the instructions provided with the filter.

**Note:** Dispose of all waste materials (engine oil, fuel, filter, etc.) in an environmentally safe manner.

#### 3. Fill with oil.

- Remove the oil fill cap and fill the engine to the F mark on the dipstick. The engine oil capacity is 1.9 L (2.0 qt.). See Section 3.3.3, Engine Oil Recommendation, for oil selection.
- Reinstall the dipstick and the oil fill cap.
- Check that the generator set master switch is in the OFF position.

- d. Reconnect the generator set engine starting battery, negative (-) lead last.
- e. Reconnect the power to the battery charger.
- f. Start and run the generator set for a minute to allow the oil pressure to reach the operating range.
- g. Stop the generator set, wait 1 minute, and then recheck the oil level. Add oil to bring the level up to the F mark on the dipstick.

#### 4. Check for leaks.

- a. Check for oil leaks.
- b. Fix leaks and recheck the oil level.
- c. Reinstall the housing side panel.

### 3.4 Spark Plugs

Reset the spark plug gap or replace the plugs with new plugs as necessary.

1. Clean the area around the base of the spark plug to keep dirt and debris out of the engine.
2. Remove the spark plug and check its condition. Replace the spark plug if it is worn or if its reuse is questionable.
3. Check the spark plug gap using a wire feeler gauge. Adjust the gap to 0.76 mm (0.030 in.) by carefully bending the ground electrode. See Figure 3-3 and Figure 3-4.

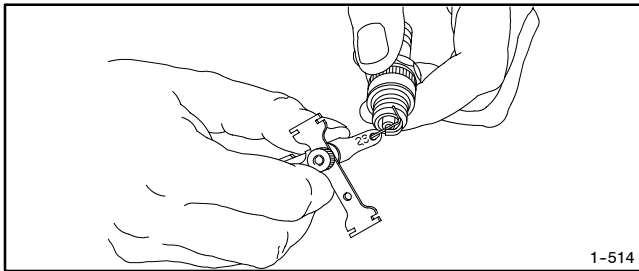

**Figure 3-3** Checking the Spark Plug Gap

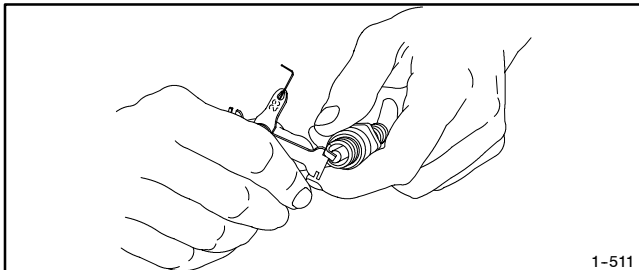

**Figure 3-4** Adjusting the Spark Plug Gap

### 3.5 Air Cleaner Element and Precleaner

The engine has a replaceable high-density paper air cleaner element with an oiled foam precleaner. See Figure 3-5.

Check for a buildup of dirt and debris around the air cleaner system. Keep this area clean.

**Note:** Operating the engine with loose or damaged air cleaner components could allow unfiltered air into the engine causing premature wear and failure.

#### 3.5.1 Precleaner Service

Use the following procedure to wash and reoil the precleaner as indicated in the service schedule. Wash and reoil the precleaner more often under extremely dusty or dirty conditions.

1. Place the generator set master switch in the OFF/RESET position.
2. Disconnect the power to the battery charger.
3. Disconnect the battery, negative (-) lead first.
4. Loosen the cover retaining knob and remove the cover. Remove the precleaner from the paper element. Wash the precleaner in warm water with detergent. Rinse the precleaner thoroughly until all traces of detergent are eliminated. Squeeze out excess water (do not wring). Allow the precleaner to air dry.
5. Saturate the precleaner with new engine oil. Squeeze out all of the excess oil.
6. Reinstall the precleaner over the paper element.
7. Reinstall the air cleaner cover. Secure the cover with the cover retaining knob.
8. Reconnect the power to the battery charger.
9. Reconnect the generator set engine starting battery, negative (-) lead last.

#### 3.5.2 Paper Element Service

Use the following procedure to replace the paper element at the intervals specified in the service schedule. Replace the paper element more often under extremely dusty or dirty conditions.

1. Place the generator set master switch in the OFF/RESET position.
2. Disconnect the power to the battery charger.
3. Disconnect the generator set engine starting battery, negative (-) lead first.
4. Loosen the cover retaining knob and remove the cover.
5. Remove the element cover nut, element cover, and the paper element with precleaner.
6. Remove the precleaner from the paper element.

**Note:** Do not wash the paper element or clean it with pressurized air, as this will damage the element.

7. Replace the element if it is dirty, bent, or damaged.
8. Check the air cleaner base. Make sure it is secure and not bent or damaged. Also check the element cover for damage and fit. Replace all damaged air cleaner components. Remove any loose dirt or debris from the air cleaner base. Wipe the base carefully so that no dirt drops into the intake throat. Check the condition of the rubber seal on the air cleaner stud and replace the seal if necessary.
9. Reinstall the paper element, precleaner, element cover, element cover nut, and the air cleaner cover. Secure the cover with the cover retaining knob.

10. Reconnect the power to the battery charger.
11. Reconnect the generator set engine starting battery, negative (-) lead last.

### 3.6 Cooling System

The engine fan draws cooling air through the openings in the sides and end near the battery. The alternator fan draws cooling air through openings on the side walls of the enclosure. The cooling air mixes with the engine exhaust and is discharged at the exhaust outlet. See Figure 3-6. To prevent generator set damage caused by overheating, keep the housing cooling inlets and outlets clean and unobstructed at all times.

**Note:** Do not block the generator set cooling air inlets or mount other equipment above them. Overheating and severe generator damage may occur.

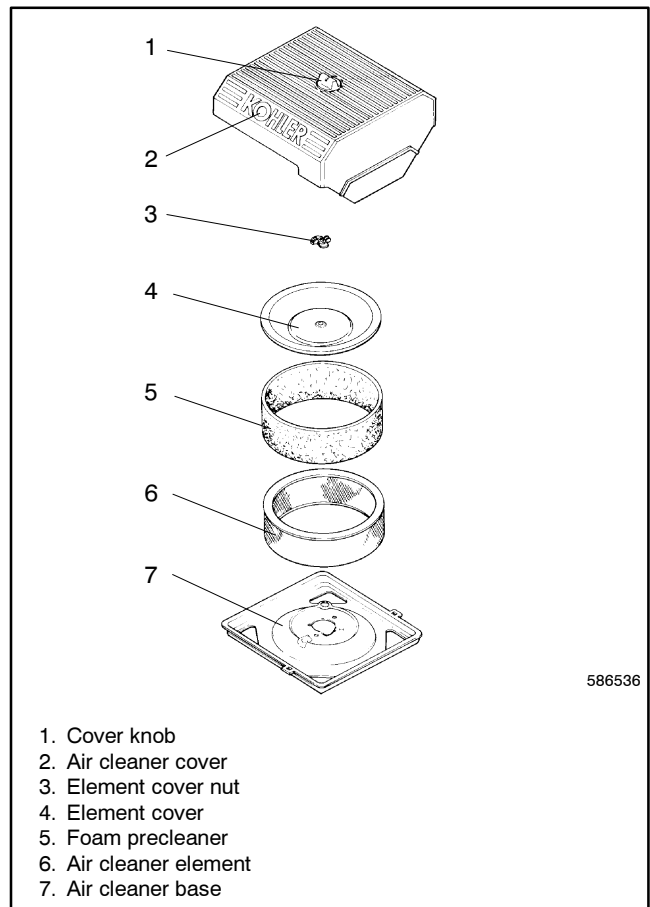

**Figure 3-5** Air Cleaner Components

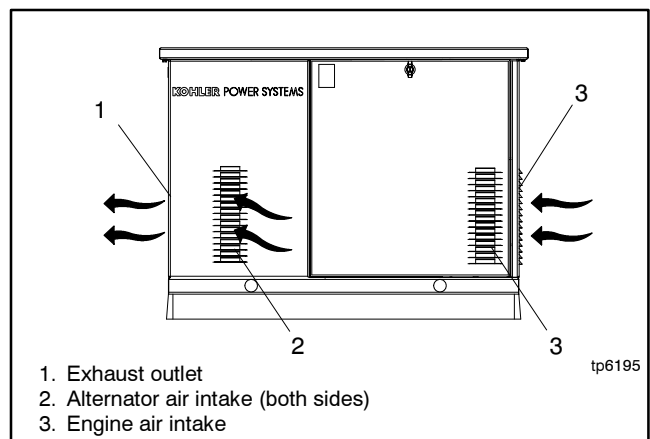

**Figure 3-6** Cooling Air Intake and Exhaust

## 3.7 Exhaust System

Remove all combustible materials from the exhaust location. Combustible materials include building materials as well as natural surroundings. Keep dry field grass, foliage, and combustible landscaping material a minimum of 0.3 m (1 ft.) from the exhaust outlet.

Periodically inspect the exhaust system components (exhaust manifold, exhaust line, flexible exhaust, clamps, silencer, and outlet pipe) for cracks, leaks, and corrosion.

- Check for corroded or broken metal parts and replace them as needed.
- Check for loose, corroded, or missing clamps and hangers. Tighten or replace clamps and/or hangers as needed.
- Check for and remove loose insulation in the exhaust duct.
- Check that the exhaust outlet is clear.

## 3.8 Battery

---

### WARNING



#### **Sulfuric acid in batteries. Can cause severe injury or death.**

Wear protective goggles and clothing.  
Battery acid may cause blindness and burn skin.

---

**Battery electrolyte is a diluted sulfuric acid. Battery acid can cause severe injury or death.** Battery acid can cause blindness and burn skin. Always wear splashproof safety

goggles, rubber gloves, and boots when servicing the battery. Do not open a sealed battery or mutilate the battery case. If battery acid splashes in the eyes or on the skin, immediately flush the affected area for 15 minutes with large quantities of clean water. Seek immediate medical aid in the case of eye contact. Never add acid to a battery after placing the battery in service, as this may result in hazardous spattering of battery acid.

**Battery acid cleanup. Battery acid can cause severe injury or death.** Battery acid is electrically conductive and corrosive. Add 500 g (1 lb.) of bicarbonate of soda (baking soda) to a container with 4 L (1 gal.) of water and mix the neutralizing solution. Pour the neutralizing solution on the spilled battery acid and continue to add the neutralizing solution to the spilled battery acid until all evidence of a chemical reaction (foaming) has ceased. Flush the resulting liquid with water and dry the area.

**Battery gases. Explosion can cause severe injury or death.** Battery gases can cause an explosion. Do not smoke or permit flames or sparks to occur near a battery at any time, particularly when it is charging. Do not dispose of a battery in a fire. To prevent burns and sparks that could cause an explosion, avoid touching the battery terminals with tools or other metal objects. Remove all jewelry before servicing the equipment. Discharge static electricity from your body before touching batteries by first touching a grounded metal surface away from the battery. To avoid sparks, do not disturb the battery charger connections while the battery is charging. Always turn the battery charger off before disconnecting the battery connections. Ventilate the compartments containing batteries to prevent accumulation of explosive gases.

**Battery short circuits. Explosion can cause severe injury or death.** Short circuits can cause bodily injury and/or equipment damage. Disconnect the battery before generator set installation or maintenance. Remove all jewelry before servicing the equipment. Use tools with insulated handles. Remove the negative (-) lead first when disconnecting the battery. Reconnect the negative (-) lead last when reconnecting the battery. Never connect the negative (-) battery cable to the positive (+) connection terminal of the starter solenoid. Do not test the battery condition by shorting the terminals together.

Refer to this section for general battery information and maintenance. All generator set models use a negative ground with a 12-volt engine electrical system. Consult the generator set nameplate for the engine electrical system voltage. Consult the generator spec sheet for battery capacity recommendations for replacement purposes. Wiring diagrams provide battery connection information. See Figure 3-7 for typical battery connections.

Check the electrolyte level and specific gravity of batteries with filler caps. Maintenance-free batteries do not require electrolyte level checking or specific gravity testing.

Clean the battery and cables and tighten battery terminals using the service schedule recommendations. Clean the battery by wiping it with a damp cloth. Clean both battery terminals with baking soda. Keep the electrical connections dry and tight.

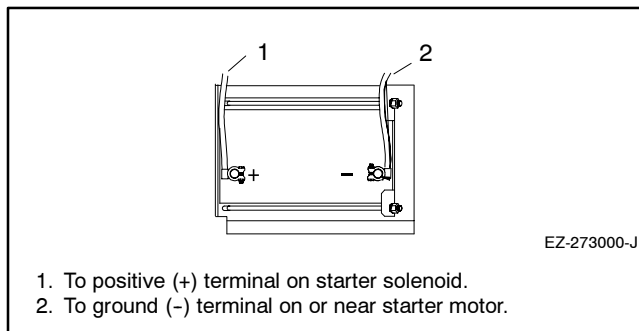

**Figure 3-7** 12-Volt Engine Electrical System Single Starter Motor, Typical Battery Connection

### 3.8.1 Cleaning the Battery

To prevent dirt and grime buildup, occasionally wipe the battery with a damp cloth.

To prevent corrosion, maintain tight, dry electrical connections at the battery terminals. To remove corrosion from battery terminals, disconnect the cables

from the battery and scrub the terminals with a wire brush. Clean the battery and cables with a solution of baking soda and water. Do not allow the cleaning solution to enter the battery's cells. After cleaning, flush the battery and cables with clean water and wipe them with a dry, lint-free cloth.

After reconnecting the battery cables, coat the battery terminals with petroleum jelly, silicone grease, or other nonconductive grease.

### 3.8.2 Checking Battery Electrolyte Level

Check the battery electrolyte level before each startup. Remove the filler caps and verify that the electrolyte level reaches the bottoms of the filler holes; see Figure 3-8. Refill as necessary with distilled water or clean tap water. Do not add electrolyte. Install and tighten filler caps. After adding water to the battery in freezing temperatures, run the generator set 20-30 minutes to mix the added water and the battery electrolyte. Mixing the water and the electrolyte prevents the added water from freezing and damaging the battery.

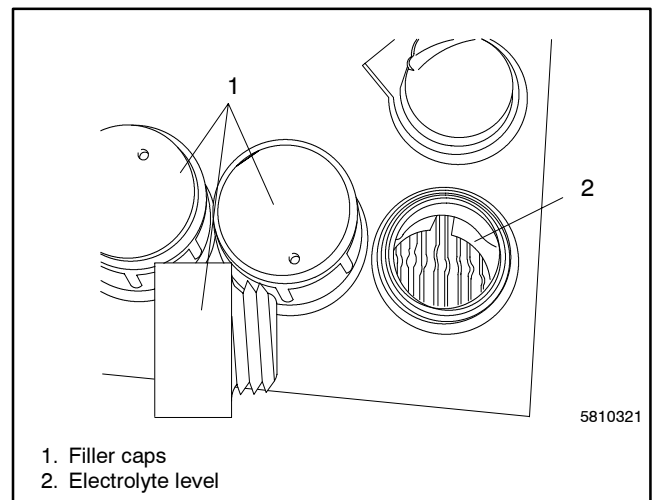

**Figure 3-8** Checking Electrolyte Level

### 3.8.3 Checking Electrolyte Specific Gravity

Use a battery hydrometer to check the specific gravity of the electrolyte in each battery cell. Use the hydrometer's test instructions, if available, or Figure 3-9 for bead-type testers.

Number of Beads Floating	Battery Condition
5	Overcharged
4	Full Charge
3	Adequate Charge
1, 2	Low Charge
0	Battery Dead

**Figure 3-9** Electrolyte Testing Chart

Temperature affects specific gravity; correct the indicated hydrometer readings for temperature. If the hydrometer does not have a correction table, use Figure 3-10. A fully charged battery should have a specific gravity of 1.260 with the electrolyte at 26.7°C (80°F). Charge the battery if the specific gravity from cell to cell varies by more than 0.01. Charge the battery if the specific gravity is less than 1.215 with the electrolyte at 26.7°C (80°F).

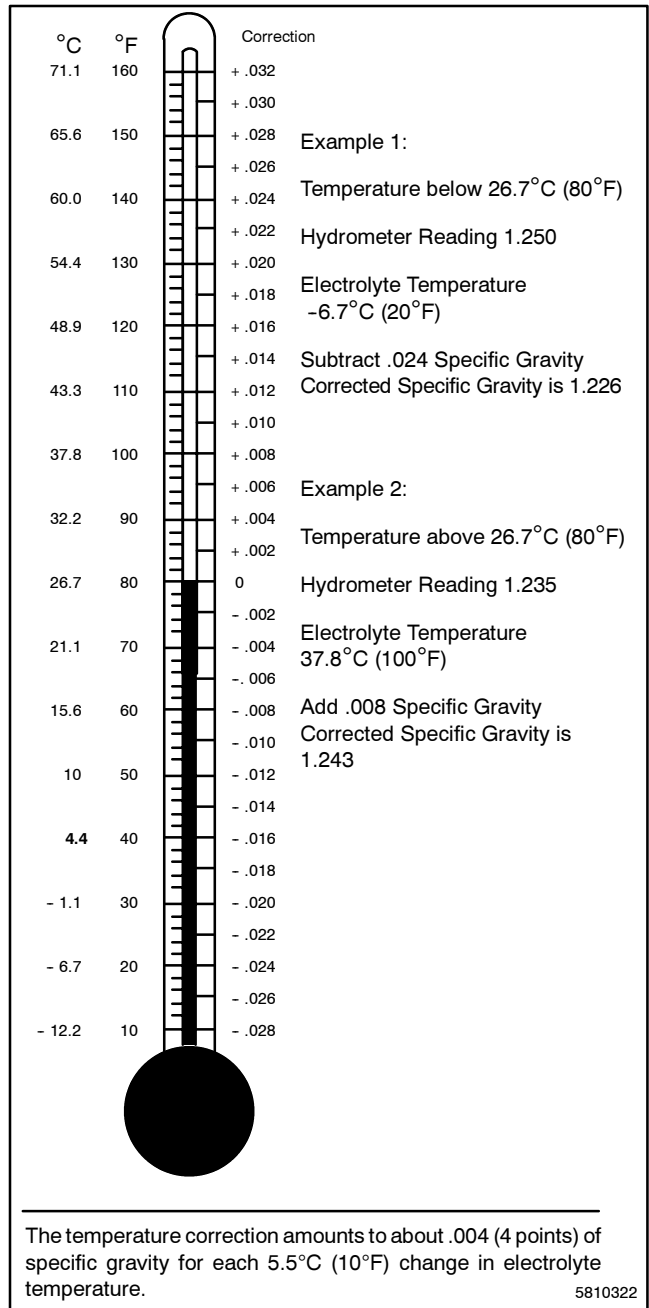

**Figure 3-10** Specific Gravity Temperature Correction

## 3.9 Battery Charger

The generator set is equipped with a 6-amp float/equalize battery charger to maintain the engine starting battery. The charger's DC leads are factory-wired. Figure 3-11 illustrates the battery charger.

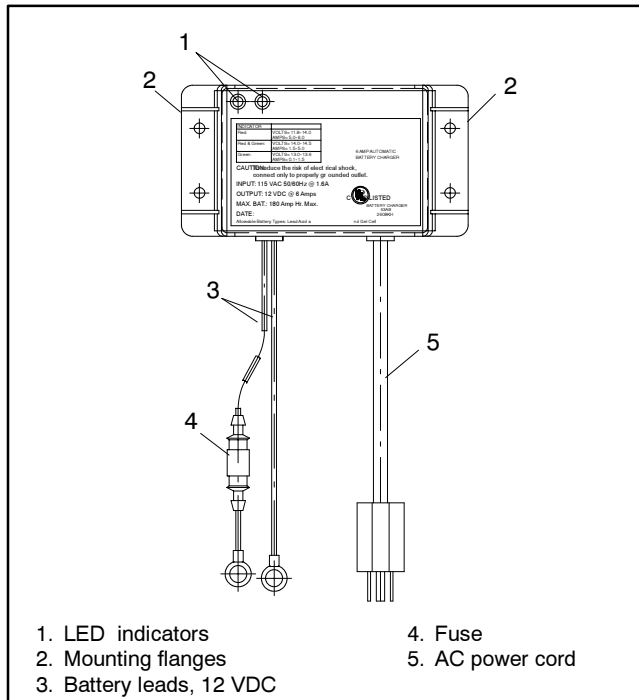

**Figure 3-11** 6-Amp Float/Equalize Battery Charger

Periodically tighten all connections. No other maintenance on the battery charger is required.

## 3.10 Storage Procedure

Perform the following storage procedure before removing the generator set from service for three months or longer. Follow the engine manufacturer's recommendations for storage, if available.

**Note:** Run the generator set monthly whenever possible.

### 3.10.1 Lubricating System

1. Operate the generator set until it reaches operating temperature, or about 15 minutes.

2. Stop the generator set.
3. While the engine is still warm, drain the engine lubrication oil from the engine crankcase.
4. Refill the engine crankcase with oil. See Section 3.3.3 for oil recommendations.
5. Run the generator set for a few minutes to distribute the clean oil.
6. Stop the generator set.

### 3.10.2 Fuel System

1. Start the generator set.
2. With the generator set running, shut off the gas supply.
3. Run the generator set until the engine stops.
4. Place the generator set master switch in the OFF/RESET position.

### 3.10.3 Cylinder Lubrication

1. Remove the spark plugs.
2. Pour one tablespoon of engine oil into each spark plug hole. Install the spark plugs and *ground* the spark plug leads. *Do not connect the leads to the plugs.*
3. Toggle the generator set master switch to crank the engine two or three revolutions to lubricate the cylinders.

### 3.10.4 Exterior Preparation

1. Clean the exterior surface of the generator set.
2. Seal all openings in the engine with nonabsorbent adhesive tape.
3. Mask all areas to be used for electrical contact.
4. Spread a light film of oil over unpainted metallic surfaces to prevent rust and corrosion.

### **3.10.5 Battery**

Perform battery storage last.

1. Place the generator set master switch in the OFF/RESET position.
2. Disconnect the battery, negative (-) lead first.
3. Clean the battery. Refer to Section 3.8.1 for the cleaning procedure.
4. Place the battery in a warm, dry location.
5. Connect the battery to a float/equalize battery charger, or charge the battery monthly using a trickle charger. Follow the battery charger manufacturer's recommendations.

## Section 4 Troubleshooting

### 4.1 Introduction

Use the following charts to diagnose and correct common problems. First check for simple causes such as a dead engine starting battery, loose connections, or an open circuit breaker. The charts include a list of common problems, possible causes of the problem, and recommended corrective actions.

If the procedures in this manual do not explain how to correct the problem, contact an authorized distributor/

dealer. Maintain a record of repairs and adjustments performed on the equipment. Use the record to help describe the problem and repairs or adjustments made to the equipment.

### 4.2 Generator Set Troubleshooting

Figure 4-1 contains generator set troubleshooting, diagnostic, and repair information. Check for loose connections before replacing parts.

Problem	Possible Cause	Corrective Action
The generator set does not crank.	Battery weak or dead Battery charger fuse blown Battery connections reversed or poor Controller fuse (F3) blown Relay interface board fuse (F2) blown Generator set master switch in the OFF position	Check power to the battery charger. Recharge or replace the battery. Replace the fuse. Contact an authorized distributor/dealer for service if fuse blows repeatedly. Check the connections. Replace the fuse. Contact an authorized distributor/dealer for service if fuse blows repeatedly. Replace the fuse. Contact an authorized distributor/dealer for service if fuse blows repeatedly. Move the master switch to the RUN position.
The generator set cranks but does not start, starts hard, lacks power, or operates erratically.	Air cleaner clogged Battery weak or dead Battery connection poor Spark plug wire connection loose Low oil pressure shutdown Fuel pressure insufficient Engine malfunction	Clean and/or replace the air cleaner. Check power to the battery charger. Recharge or replace the battery. Clean and tighten the battery connections. Check the spark plug wires. Check the oil level. Check the fuel supply and valves. Contact the distributor/dealer.
No AC output.	AC circuit breaker in the OFF position AC circuit breaker tripping because of overload AC circuit breaker tripping because of short circuit	Place the circuit breaker in the ON position. Reduce the load on the generator set. Contact an authorized distributor/dealer for service.
Low output or excessive drop in voltage.	Generator set overloaded	Reduce the load.
Generator set stops suddenly.	Low oil pressure shutdown Out of fuel Overcrank shutdown Controller fuse (F3) blown Overspeed shutdown Generator set master switch in the OFF/RESET position Remote stop command received from a remote switch or ATS Engine malfunction Auxiliary winding fuse (F1) blown	Check the oil level. Check fuel supply. Reset the controller. If the overcrank fault occurs again, contact the distributor/dealer. Replace the fuse. If the fuse blows again, contact the distributor/dealer. Reset the controller. If the overspeed fault occurs again, contact the distributor/dealer. Move the switch to the correct position (RUN or AUTO). Check the remote switch position. Contact the distributor/dealer. Replace the fuse. Contact an authorized distributor/dealer for service if fuse blows repeatedly.

Figure 4-1 General Troubleshooting Chart

### 4.3 Fault Codes

The Advanced Digital Control displays fault codes to aid in troubleshooting. Fault codes, descriptions, and recommended actions are listed in Figure 2-3.

Identify and correct the cause of the fault condition. Then reset the controller after a fault shutdown. See Section 2.3.5.

### 4.4 Controller Troubleshooting

Figure 4-2 contains troubleshooting, diagnostic, and repair information for the Advanced Digital Control.

Problem	Possible Cause	Corrective Action
Controller LED display is off	No power to the controller:  Continuous power mode jumper is disconnected and the generator set has not run for 48 hours or longer.	Controller display will automatically activate when a remote start command is received or the generator set master switch is moved to the RUN position. Connect the jumper to maintain continuous power to the controller, if desired. See Sections 2.3.6 and 6.9.3.
	Controller fuse (F3) is blown.	Replace the fuse. If the fuse blows again, contact the distributor/dealer.
	Low or no battery voltage.	Check connections. Check generator set battery and battery charger. See Figure 4-1.
	Generator set master switch is in the OFF/RESET position.	Move generator set master switch to the AUTO or RUN position.
	Generator set master switch in AUTO but no start command has been received since last controller reset.	No action required (see Section 2.3.1). Controller display will activate when a remote start command is received or the generator set master switch is moved to the RUN position. Use the remote switch to start generator set and activate the controller display, if desired.

**Figure 4-2** Controller Troubleshooting Chart

Problem	Cause	Solution
Red LED stays on for more than 24 hours	One or more defective or damaged cells.	Load test the battery and replace, if necessary
	Battery charger has reduced its output voltage below the normal level due to a DC overload or a DC short.	Remove the source of the overload or short. Disconnect the battery charger's black (NEGATIVE) ring terminal from the battery. Reapply AC power and the green LED only should now light.
	Onboard DC systems are drawing more current than the battery charger can replace.	Turn off all DC equipment while charging.
Red and green LEDs stay on for more than 24 hours	Onboard DC systems are drawing between 1.5 and 5 amps.	Turn off all DC equipment while charging.
	One or more defective or damaged cells.	Load test the battery and replace, if necessary
	Extremely low AC voltage at the battery charger.	Apply a higher AC voltage source or reduce the length of the extension cord.
Green LED stays on when the battery is known to be low	Open DC output fuse.	Replace AGS-10 fuse.
	Faulty or contaminated terminal connections.	Clean and tighten or repair all terminal connections.
	One or more defective or damaged cells.	Load test the battery and replace, if necessary.
Neither of the LEDs turn on when the AC power is applied	No AC power available at the battery charger.	Connect AC power or reset the AC breaker on the main panel.
	Component failure.	Replace battery charger.

**Figure 4-3** Battery Charger Troubleshooting

### 4.5 Battery Charger Troubleshooting

Use the battery charger's LED indicators and the table in Figure 4-3 to troubleshoot battery charger operation problems.

## Section 5 Wiring Diagrams

### 5.1 Specification Numbers

At the time of print, this manual applied to the model numbers and specification (spec) numbers in Figure 5-1. On occasion the manufacturer may provide this manual with units that are not listed below, such as when similar new specs are created prior to the updated reprint or in other cases when the manual is a suitable substitute for a manual under development.

Model No.	Spec. No.
8.5RES	GM29253-GA1
12RES	GM29253-GA2

**Figure 5-1** Generator Set Specification Numbers

### 5.2 Controller Wiring Diagram Reference

Figure 5-2 lists the wiring diagram numbers and locations.

Wiring Diagram Description	Drawing Number	Page
Schematic Diagram		
Sheet 1	ADV-6835A	22
Sheet 2	ADV-6835B	23
Point-to-Point Wiring Diagram	GM29358	24

**Figure 5-2** Controller Wiring Diagrams

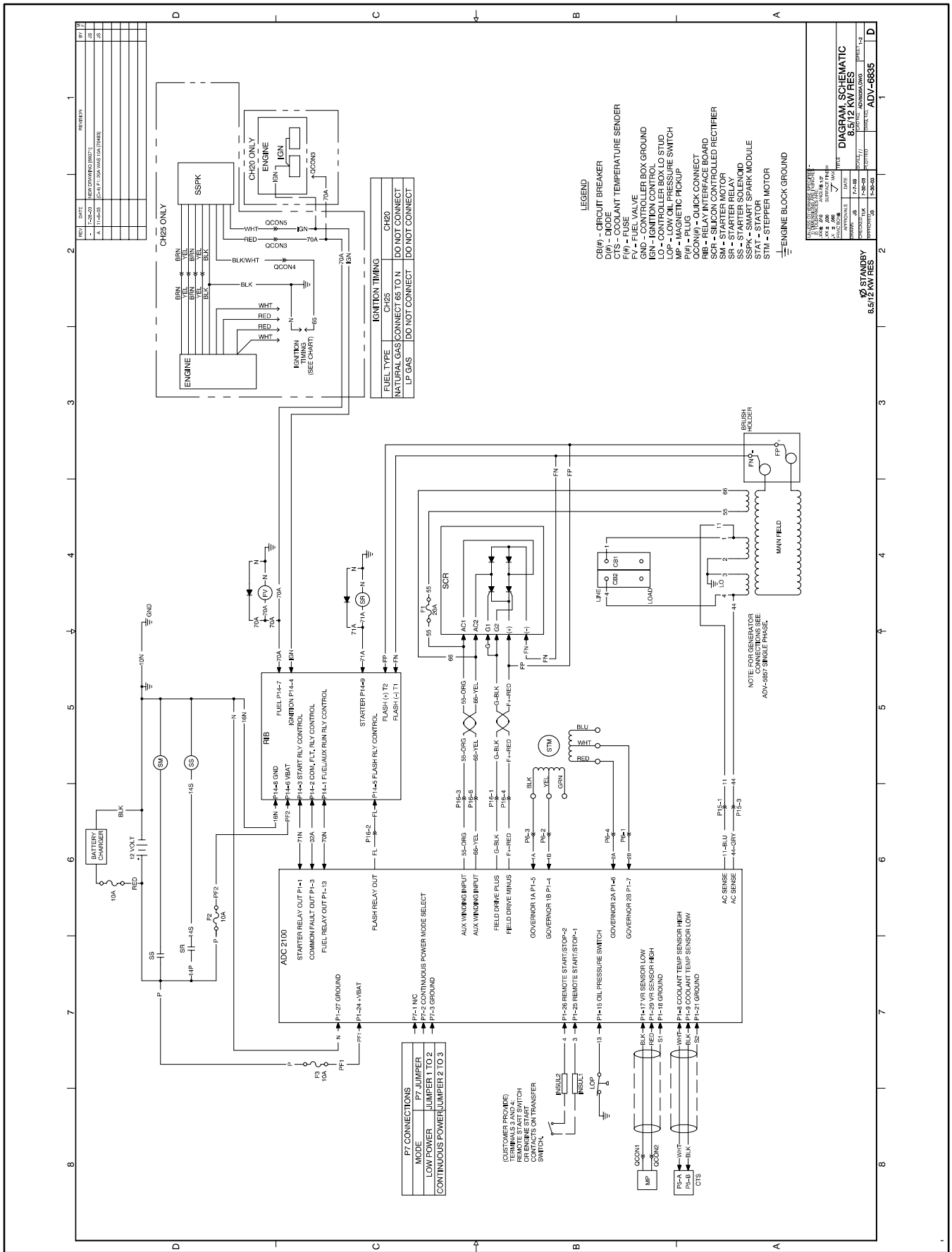

Figure 5-3 8.5/12RES Schematic Diagram, Single Phase, Sheet 1, ADV-6835A-A

RELAY INTERFACE BOARD

- P13 CONNECTIONS**  
P13-1 RUN RELAY COMMON  
P13-2 COMMON FAULT COMMON  
P13-3 COMMON FAULT NC  
P13-4 RUN RELAY NO  
P13-5 RUN RELAY NC  
P13-6 COMMON FAULT NO
- P14 CONNECTIONS**  
P14-1 FUEL/AUX RUN RELAY CONTROL  
P14-2 COMMON FAULT RELAY CONTROL  
P14-3 STARTER RELAY CONTROL  
P14-4 IGNITION NEGATIVE  
P14-5 FLASH RELAY CONTROL  
P14-6 VBAT  
P14-7 FUEL (70A)  
P14-8 GROUND  
P14-9 STARTER (71A)

ADC 2100 CONTROLLER

- P1 CONNECTIONS**  
P1-1 STARTER RELAY OUT  
P1-2 SPARE OUTPUT  
P1-3 COMMON FAULT  
P1-4 GOVERNOR 1B  
P1-5 GOVERNOR 1A  
P1-6 GOVERNOR 2A  
P1-7 GOVERNOR 2B  
P1-8 COOLANT TEMP SENSOR HIGH  
P1-9 COOLANT TEMP SENSOR LOW  
P1-10 EXTERNAL CAN H  
P1-11 EXTERNAL CAN L  
P1-12 AUX SHUTDOWN  
P1-13 FUEL RELAY OUT  
P1-14 TACH OUT  
P1-15 OIL PRESSURE SWITCH  
P1-16 GROUND  
P1-17 VR SENSOR LOW  
P1-18 GROUND  
P1-19 PRESSURE SENSOR GROUND  
P1-20 GROUND  
P1-21 GROUND  
P1-22 GROUND  
P1-23 GROUND  
P1-24 VBAT +  
P1-25 REMOTE START/STOP 1  
P1-26 REMOTE START/STOP 2  
P1-27 GROUND  
P1-28 COOLANT LEVEL/LOSS HIGH  
P1-29 VR SENSOR HIGH  
P1-30 PRESSURE SENSOR SOURCE  
P1-31 PRESSURE SENSOR SIGNAL  
P1-32 GROUND  
P1-33 VBAT ON  
P1-34 GROUND  
P1-35 RS232 TXD
- P5 CONNECTIONS**  
P5-1 N/C  
P5-2 RS232 RXD  
P5-3 RS232 TXD  
P5-4 N/C  
P5-5 GROUND  
P5-6 N/C  
P5-7 N/C  
P5-8 N/C  
P5-9 N/C
- P7 CONNECTIONS**  
P7-1 N/C  
P7-2 CONTINUOUS POWER MODE SELECT  
P7-3 GROUND
- J16 CONNECTIONS**  
J16-1 FIELD DRIVE PLUS (G)  
J16-2 FLASH RELAY OUT  
J16-3 AUX WINDING INPUT (55)  
J16-4 FIELD DRIVE MINUS (F+)  
J16-5 N/C  
J16-6 AUX WINDING INPUT (66)
- J15 CONNECTIONS**  
J15-1 AC INPUT (V7/11)  
J15-2 AC INPUT (V8)  
J15-3 AC INPUT (V9/44)

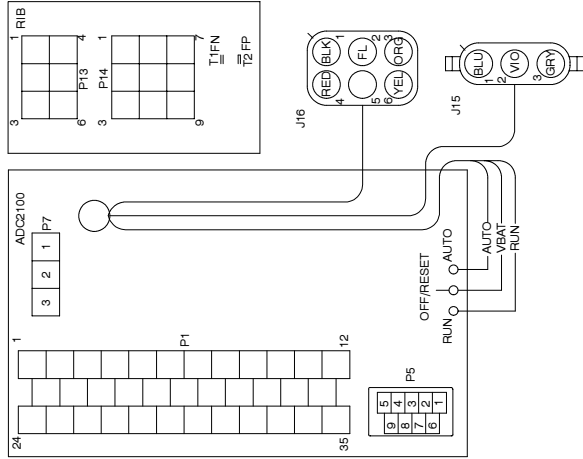

**Figure 5-4** 8.5/12RES Schematic Diagram, Single Phase, Sheet 2, ADV-6835B



## 6.1 General

Have an authorized distributor/dealer install the generator set outdoors according to the instructions in this section. Do not install this generator set indoors. The generator set installation must comply with state and local code requirements.

Use the specifications provided here only in the initial planning. Use the generator set and transfer switch spec sheets, dimension drawings, and wiring diagrams for installation. Contact an authorized service distributor/dealer for the most current information.

## 6.2 Weight

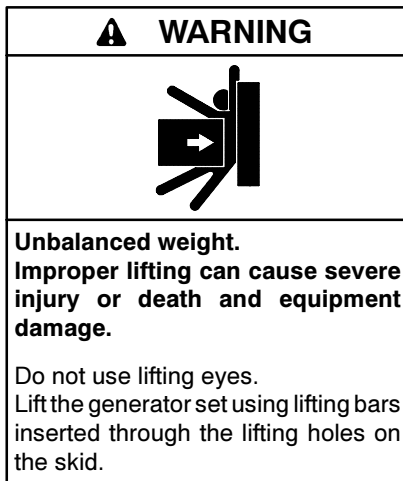

The generator set weighs approximately 186 kg (410 lb.). Use lifting bars inserted through the holes in the skid to lift the unit. See Figure 6-1 for lifting hole locations.

## 6.3 Generator Set Inspection

Complete a thorough inspection of the generator set. Check for the following:

1. Inspect the generator set for loose or damaged parts or wires. Repair or tighten any loose parts before installation.
2. Check the engine oil. Fill, if necessary, with the recommended make and grade of oil. See Section 3.3.3 for engine oil recommendations.

## 6.4 Mounting

Install the generator set outdoors. Maintain a minimum clearance of 0.9 m (3 ft.) from any building as shown in Figure 6-1. Do not install the generator set where exhaust gas could accumulate and seep inside or be drawn into a potentially occupied building. Mount the generator set so that the hot exhaust does not blow on plants or other combustible materials.

See Figure 6-1 for the generator set dimensions and fuel and electric inlet locations. The drawing dimensions are shown in millimeters, with inches in brackets.

The generator set is shipped on a plastic mounting pad. Prepare a flat, level mounting area covered with gravel or compacted soil. Set the plastic mounting pad directly on the gravel or compacted soil. Do not install the mounting pad directly on the grass.

## 6.5 Exhaust Requirements

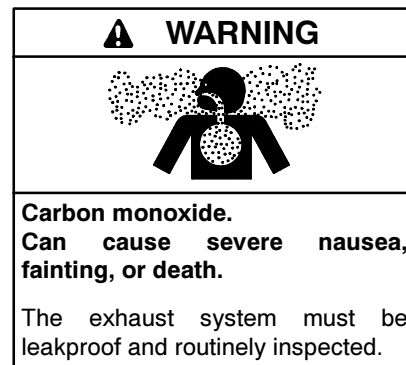

**Generator set operation. Carbon monoxide can cause severe nausea, fainting, or death.** Carbon monoxide is an odorless, colorless, tasteless, nonirritating gas that can cause death if inhaled for even a short time. Avoid breathing exhaust fumes when working on or near the generator set. Never operate the generator set inside a building. Never operate the generator set where exhaust gas could seep inside or be drawn into a potentially occupied building through windows, air intake vents, or other openings.

The exhaust system is complete for generator sets installed outdoors. Do not install this generator set indoors.



Figure 6-2 gives the exhaust flow and temperature at rated load. Mount the generator set so that the hot exhaust does not blow on plants or other combustible materials.

Exhaust System	60 Hz	50 Hz
Exhaust flow at rated kW, m <sup>3</sup> /min. (cfm)		
8.5RES	3.3 (115)	2.7 (96)
12RES	3.8 (135)	3.2 (113)
Exhaust temperature at rated kW, dry exhaust, °C (°F)	816 (1500)	

**Figure 6-2** Exhaust Flow and Temperature

## 6.6 Air Requirements

The generator set requires correct air flow for cooling and combustion. The inlet and outlet openings in the sound enclosure provide the cooling and combustion air. Figure 6-3 shows the locations of the cooling air intake and exhaust vents. Inspect the air inlet and outlet openings inside and outside the housing to ensure that the air flow is not blocked.

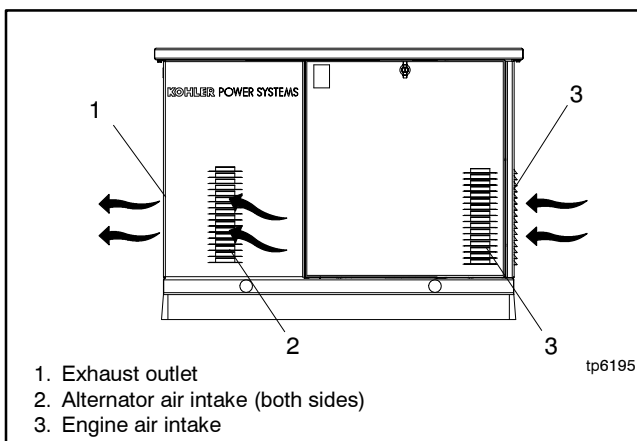

**Figure 6-3** Cooling Air Intake and Exhaust

Cooling Air Requirements	8.5RES		12RES	
	60 Hz	50 Hz	60 Hz	50 Hz
Cooling air, m <sup>3</sup> /min. (cfm)	26.9 (950)	22.4 (790)	26.9 (950)	22.4 (790)
Total inlet air requirement, m <sup>3</sup> /min. (cfm)	27.8 (980)	23.2 (820)	28.0 (990)	23.4 (825)
Combustion air, m <sup>3</sup> /min. (cfm)	0.94 (33.4)	0.8 (28.0)	1.1 (39.2)	0.9 (32.6)

**Figure 6-4** Cooling Air Requirements

## 6.7 Power Supply

Utility power must be supplied to the generator set location. Provide a 110- or 120-volt outlet connected to the utility power supply for the battery charger (standard) and carburetor heater (optional). Figure 6-5 lists the battery charger power requirements.

Input	Requirement
Rated AC voltage	90-135 VAC, 50/60 Hz
Current draw	1.6 amp at full output

**Figure 6-5** Battery Charger Power Requirements

## 6.8 Fuel System

The generator set operates using natural gas or LP vapor fuel. The multi-fuel system allows conversion from natural gas to LP vapor (or vice-versa) in the field while maintaining emissions-standard compliance. A trained technician or authorized distributor/dealer can convert the fuel system. Generator sets with multi-fuel systems are CARB- and EPA-certified for both natural gas and LP vapor fuels.

### 6.8.1 Fuel Supply

Comply with local, state, and federal codes regarding the correct storage of fuel. Because of variable climates and geographical considerations, contact an authorized service distributor/dealer for fuel system planning and installation.

Figure 6-1 shows the location of the fuel inlet connection. Bring the fuel supply lines through the rear access opening. Use flexible sections to prevent fuel line breakage caused by vibration. Remove the housing end panel and hold the fuel solenoid valve with a wrench when tightening the fuel connections. Protect all fuel lines from machinery or equipment contact, adverse weather conditions, and environmental damage.

Verify that the output pressure from the primary gas utility (or LP tank) pressure regulator is 1.7–2.7 kPa (7–11 in. water column) and that the utility gas meter flow rate is sufficient to supply the generator set plus all other gas-consuming appliances. Figure 6-8 shows the flow rate required for the generator set. Figure 6-6 lists

the recommended fuel ratings for natural gas and LP vapor fuels. Contact the natural gas utility for flow rate information or a gas meter upgrade.

Fuel System		
Fuel types	Natural Gas or LP Vapor	
Fuel supply inlet	1/2 NPT	
Fuel supply pressure, kPa (in. H <sub>2</sub> O)	1.7-2.7 (7-11)	
Nominal Fuel Rating	Btu/ft <sup>3</sup>	MJ/m <sup>3</sup>
Natural gas	1000	37
LP vapor	2500	93

**Figure 6-6** Fuel Supply

Fuel Consumption, m <sup>3</sup> /hr. (cfh)	8.5RES		12RES	
	60 Hz	50 Hz	60 Hz	50 Hz
Natural Gas at % load				
100%	3.7 (132)	3.3 (118)	5.9 (209)	4.9 (175)
75%	3.2 (113)	2.9 (101)	4.8 (168)	4.0 (141)
50%	2.6 (93)	2.3 (83)	3.6 (127)	3.0 (106)
25%	2.2 (77)	1.9 (69)	2.4 (85)	2.0 (71)
LP Vapor at % load				
100%	2.0 (72)	1.7 (61)	3.1 (108)	2.5 (89)
75%	1.3 (45)	1.1 (38)	2.5 (87)	2.0 (72)
50%	1.0 (36)	0.9 (31)	1.9 (65)	1.5 (53)
25%	0.8 (29)	0.7 (25)	1.2 (44)	1.0 (36)
LP vapor conversion factors: 8.58 ft <sup>3</sup> = 1 lb. 36.39 ft <sup>3</sup> = 1 gal.				

**Figure 6-7** Fuel Consumption

Generator Set Model	Gas Flow Rate	
	Btu/hr.	MJ/hr.
8.5RES	132,000	139
12RES	202,000	213

**Figure 6-8** Natural Gas Flow Rate

## 6.8.2 Fuel Pipe Size

Ensure that the natural gas pipe size and length meet the specifications in Figure 6-9. Measure the pipe length from the primary gas pressure regulator to the pipe connection on the generator set fuel inlet. Add 2.4 m (8 ft.) to the measured length for each 90 degree elbow. Compare the pipe size and length with the chart in Figure 6-9. If the piping is longer than the maximum length shown for that size, replace it with the specified size before proceeding.

Contact the local LP provider for LP installation information.

Pipe Size	Maximum Pipe Length m (ft.)	
	8.5RES	12RES
3/4 in. NPT	18.3 (60)	9.2 (30)
1 in. NPT	61 (200)	30 (100)
1 1/4 in. NPT	91.5 (300)	68.6 (225)

**Figure 6-9** Maximum Natural Gas Pipe Length

## 6.8.3 Fuel Conversion

### ⚠ WARNING



**Accidental starting.**  
**Can cause severe injury or death.**

Disconnect the battery cables before working on the generator set. Remove the negative (-) lead first when disconnecting the battery. Reconnect the negative (-) lead last when reconnecting the battery.

**Disabling the generator set. Accidental starting can cause severe injury or death.** Before working on the generator set or connected equipment, disable the generator set as follows: (1) Move the generator set master switch to the OFF position. (2) Disconnect the power to the battery charger. (3) Remove the battery cables, negative (-) lead first. Reconnect the negative (-) lead last when reconnecting the battery. Follow these precautions to prevent starting of the generator set by an automatic transfer switch, remote start/stop switch, or engine start command from a remote computer.

**⚠ WARNING**

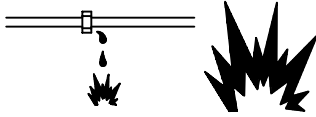

**Explosive fuel vapors.  
Can cause severe injury or death.**

Use extreme care when handling, storing, and using fuels.

The multi-fuel system allows conversion from natural gas to LP vapor (or vice-versa) in the field while maintaining emissions-standard compliance. A trained technician or authorized distributor/dealer can convert the fuel system.

Two fuel connections on the fuel block allow field-conversion between natural gas and LP vapor. The fuel metering valves are factory-set and sealed to comply with applicable emission standards and to provide the best possible hot and cold starting.

**Note:** Do not adjust the factory-sealed fuel-metering adjustments on the fuel block. Changing the fuel-metering adjustments may violate federal or state laws.

Use the following procedure to convert from natural gas to LP vapor, moving the fuel connection from the natural gas to the LP port, plugging the natural gas port, and connecting the DSAM leads. See Figure 6-10 for the fuel system component locations.

**Fuel Conversion Procedure**

1. Place the generator set master switch in the OFF position.
2. Disconnect the power to the battery charger.
3. Disconnect the generator set engine starting battery, negative (-) lead first.
4. Turn off the fuel supply.
5. Remove the hose clamp and fuel hose from the hose fitting in the fuel block. See Figure 6-11.
6. Remove the hose fitting from the natural gas outlet port in the fuel block. See Figure 6-11.

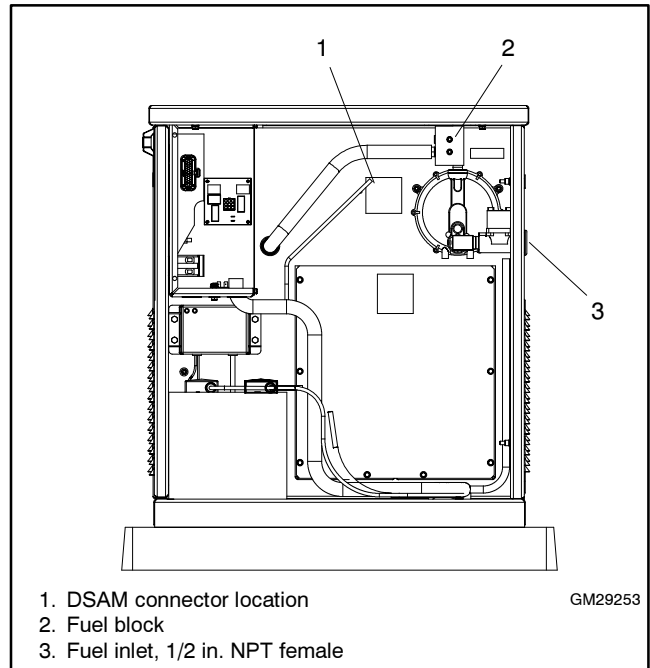

**Figure 6-10** Fuel System Locations, Air Inlet Side

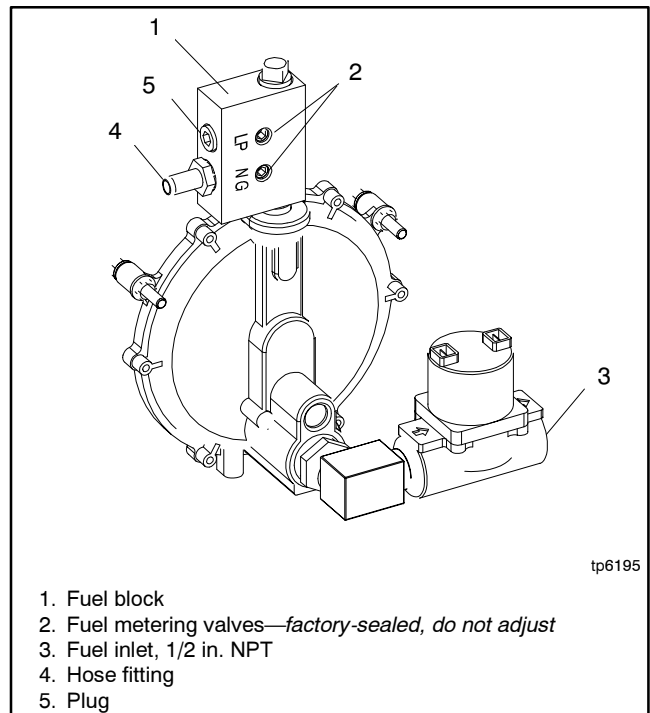
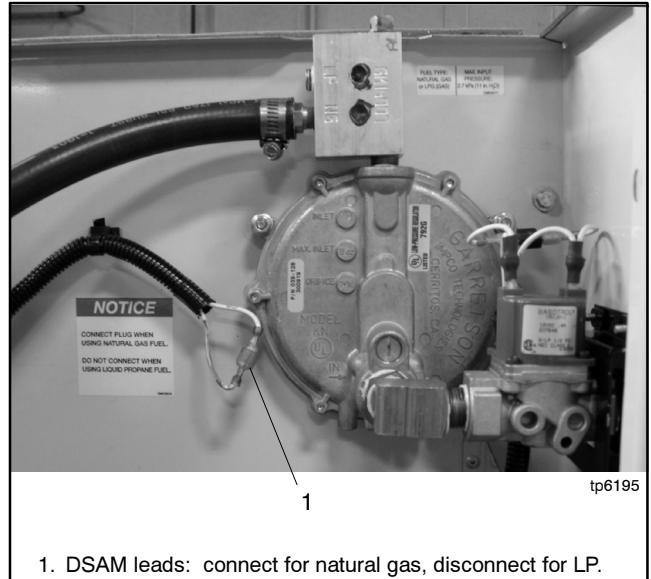

**Figure 6-11** Fuel Block Connections, Natural Gas System Shown

7. Remove the plug from the LP port in the fuel block. See Figure 6-11. Clean the plug with a dry cloth or brush, apply fresh pipe sealant, and install the plug into the natural gas outlet port.
  8. Clean the hose fitting with a dry cloth or brush, apply fresh pipe sealant to the threads, and install the fitting into the LP port.
- Note:** Do not adjust the fuel metering valves.
9. Slide the hose onto the hose fitting and secure it with the clamp.
  10. For the 12RES only: Connect the digital spark-advance module (DSAM) leads together for natural gas. (Disconnect the leads for LP.) See Figure 6-12.
  11. Connect and turn on the new fuel supply.
  12. Check that the generator set master switch is in the OFF position.
  13. Reconnect the generator set engine starting battery leads, negative (-) lead last.
  14. Reconnect power to the battery charger.
  15. Start the generator set by moving the generator set master switch to the RUN position.
  16. Check for leaks using a gas leak detector.

17. Move the generator set master switch to the AUTO position.

To convert from LP vapor to natural gas, follow the same fuel conversion procedure, moving the hose fitting to the natural gas port and plugging the LP port. For the 12RES model, disconnect the DSAM leads for LP vapor. See Figure 6-12.



**Figure 6-12** Digital Spark Advance Module (DSAM) Leads (located in generator set air intake area)

## 6.9 Electrical Connections

### 6.9.1 AC Load Lead Connections

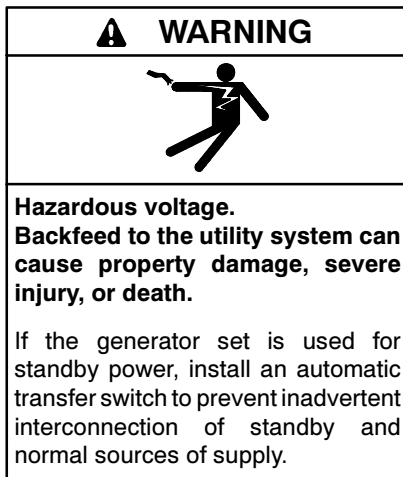

**Grounding electrical equipment. Hazardous voltage can cause severe injury or death.** Electrocutation is possible whenever electricity is present. Open the main circuit breakers of all power sources before servicing the equipment. Configure the installation to electrically ground the generator set, transfer switch, and related equipment and electrical circuits to comply with applicable codes and standards. Never contact electrical leads or appliances when standing in water or on wet ground because these conditions increase the risk of electrocution.

**Electrical backfeed to the utility. Hazardous backfeed voltage can cause severe injury or death.** Install a transfer switch in standby power installations to prevent the connection of standby and other sources of power. Electrical backfeed into a utility electrical system can cause severe injury or death to utility personnel working on power lines.

#### NOTICE

**Canadian installations only.** For standby service connect the output of the generator set to a suitably rated transfer switch in accordance with Canadian Electrical Code, Part 1.

Have an authorized distributor/dealer or a licensed electrician make the following load connections. Verify that the electrical installation complies with the National Electrical Code (NEC) and all applicable local and state codes.

Connect the AC output leads in the controller compartment to the AC circuit breaker. Route AC leads through flexible conduit directly to the AC circuit breaker box. See Figure 6-1 for the recommended electrical inlet location. Verify that the leads and conduit do not interfere with the operation of the generator set or obstruct the service areas.

See Figure 6-13 and Section 5, Wiring Diagrams, for the generator set electrical connections. Make the following AC connections:

1. Connect the output leads going to the transfer switch (L1/L2 black leads) to the AC circuit breaker load side.
2. Connect the L0 white leads from the ATS and the main panel to the neutral terminal.
3. Connect the green lead to the equipment ground terminal (labeled GRD).

Verify that the electrical installation complies with the National Electrical Code (NEC) and all applicable local and state codes.

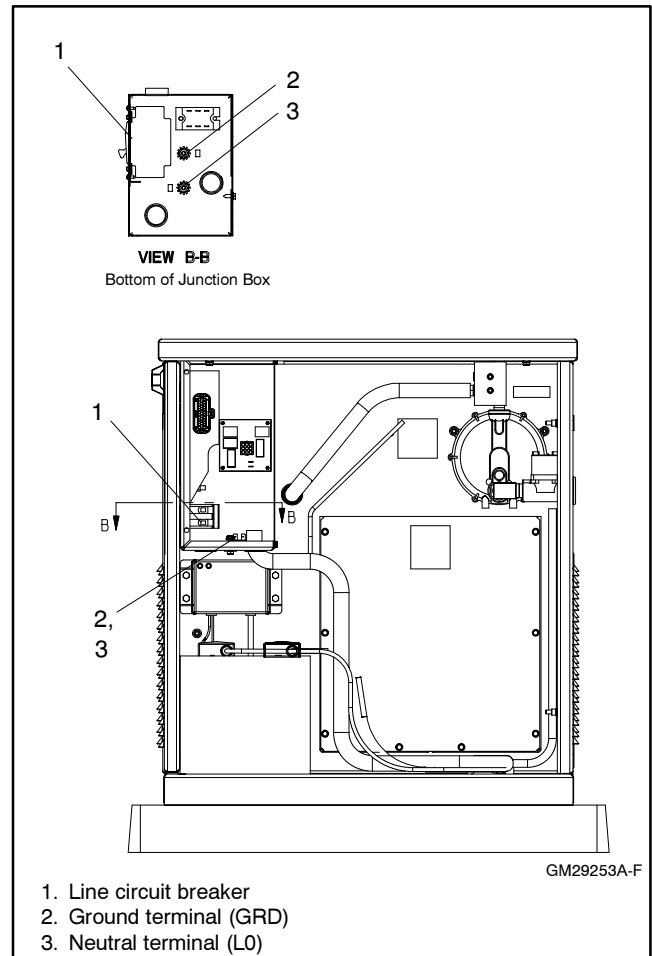

**Figure 6-13** Field-Installed Wiring Connections

## 6.9.2 Remote Start Connection (optional)

Connect leads 3 and 4 from the ADC 2100 controller to the automatic transfer switch's engine start terminals or to an optional remote start/stop switch.

## 6.9.3 Continuous Power Mode Jumper

A jumper on connector P7 on the back of the controller causes the controller to remain powered at all times. See the wiring diagram and schematic drawing in Section 5. Controllers are shipped from the factory with the jumper connected. Disconnecting the jumper allows the controller to power down 48 hours after the generator set shuts down. See Section 2.3.6.

**Note:** For most applications, it is not necessary to disconnect the continuous power mode jumper.

Use the following procedure to disconnect the jumper, if desired.

### Procedure to disconnect the continuous power mode jumper (optional).

1. Prevent the generator set from starting.
  - a. Move the generator set master switch to the OFF/RESET position.
  - b. Disconnect power to the battery charger.
  - c. Disconnect the generator set engine starting battery, negative (-) lead first.
2. Remove the controller from the generator set housing.
  - a. Disconnect the engine wiring harness connector P1 plug (35-pin) from the controller. Disconnect the J15 and J16 connectors. See Figure 6-14.
  - b. Remove the controller from the generator set housing in order to access the back of the controller.
3. Remove the controller's back cover to access the jumper.
  - a. Note the labels on the three leads connected to the generator set master switch for reconnection later. Disconnect the leads at the pink connectors. See Figure 6-14.
  - b. Remove the cover screws and remove the controller's back cover. See Figure 6-14.

4. Locate the P7 connector near the top of the controller. See Figure 6-14. Remove the jumper from pins 1 and 2 of the P7 connector. If the P7 connector has three pins, connect the jumper across pins 2 and 3 for storage.
5. Replace the controller's back cover and secure the cover screws.
6. Reconnect the three pink connectors to the generator set master switch.
7. Reconnect the J15 and J16 connectors.
8. Reconnect the generator set engine starting battery, negative (-) lead last.
9. Reconnect power to the battery charger.
10. Place the generator set master switch in the AUTO position.

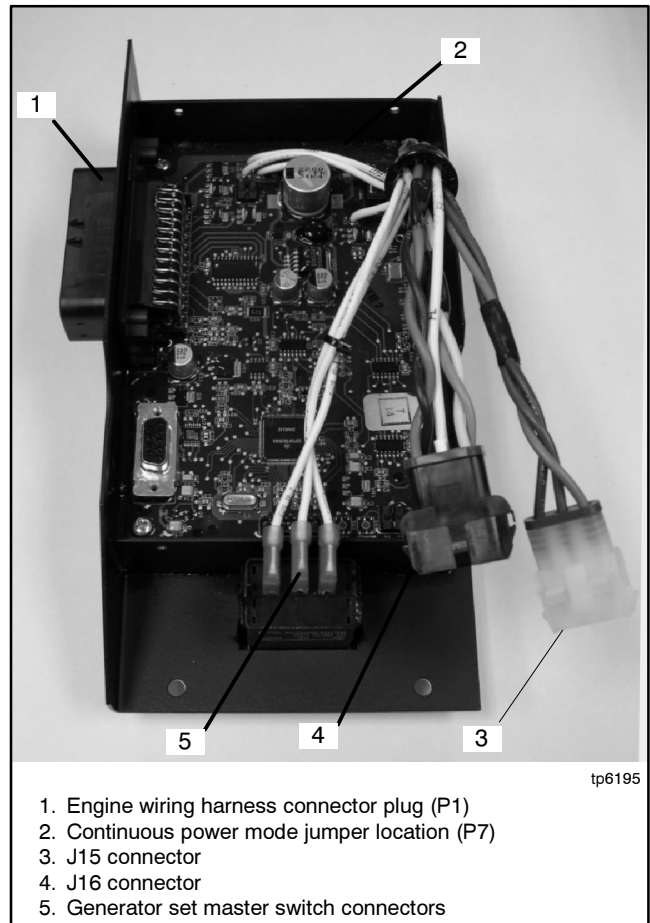

**Figure 6-14** Advanced Digital Control Connections

## 6.9.4 Battery

### WARNING



**Sulfuric acid in batteries.**  
**Can cause severe injury or death.**

Wear protective goggles and clothing. Battery acid may cause blindness and burn skin.

### WARNING



**Explosion.**  
**Can cause severe injury or death.**  
**Relays in the battery charger cause arcs or sparks.**

Locate the battery in a well-ventilated area. Isolate the battery charger from explosive fumes.

**Battery electrolyte is a diluted sulfuric acid. Battery acid can cause severe injury or death.** Battery acid can cause blindness and burn skin. Always wear splashproof safety goggles, rubber gloves, and boots when servicing the battery. Do not open a sealed battery or mutilate the battery case. If battery acid splashes in the eyes or on the skin, immediately flush the affected area for 15 minutes with large quantities of clean water. Seek immediate medical aid in the case of eye contact. Never add acid to a battery after placing the battery in service, as this may result in hazardous spattering of battery acid.

**Battery acid cleanup. Battery acid can cause severe injury or death.** Battery acid is electrically conductive and corrosive. Add 500 g (1 lb.) of bicarbonate of soda (baking soda) to a container with 4 L (1 gal.) of water and mix the neutralizing solution. Pour the neutralizing solution on the spilled battery acid and continue to add the neutralizing solution to the spilled battery acid until all evidence of a chemical reaction (foaming) has ceased. Flush the resulting liquid with water and dry the area.

**Battery gases. Explosion can cause severe injury or death.** Battery gases can cause an explosion. Do not smoke or permit flames or sparks to occur near a battery at any time, particularly when it is charging. Do not dispose of a battery in a fire. To prevent burns and sparks that could cause an explosion, avoid touching the battery terminals with tools or other metal objects. Remove all jewelry before servicing the equipment. Discharge static electricity from your body before touching batteries by first touching a grounded metal surface away from the battery. To avoid sparks, do not disturb the battery charger connections while the battery is charging. Always turn the battery charger off before disconnecting the battery connections. Ventilate the compartments containing batteries to prevent accumulation of explosive gases.

**Battery short circuits. Explosion can cause severe injury or death.** Short circuits can cause bodily injury and/or equipment damage. Disconnect the battery before generator set installation or maintenance. Remove all jewelry before servicing the equipment. Use tools with insulated handles. Remove the negative (-) lead first when disconnecting the battery. Reconnect the negative (-) lead last when reconnecting the battery. Never connect the negative (-) battery cable to the positive (+) connection terminal of the starter solenoid. Do not test the battery condition by shorting the terminals together.

**Connecting the battery and the battery charger. Hazardous voltage can cause severe injury or death.** Reconnect the battery correctly, positive to positive and negative to negative, to avoid electrical shock and damage to the battery charger and battery(ies). Have a qualified electrician install the battery(ies).

Use a 12-volt battery with a minimum rating of 675 cold cranking amps at 0°F. The generator set uses a negative ground with a 12-volt engine electrical system. See Figure 6-15 for battery connections. Make sure that the battery is correctly connected and the terminals are tight.

**Note:** The generator set will not start and circuit board damage may occur if the battery is connected in reverse.

Figure 6-16 shows the location of the engine starting battery. Standard battery cables provide easy connection to the battery. Use the following procedure to install and connect the battery.

**Battery Installation Procedure**

1. Ensure that the starting battery is fully charged before placing the battery in service.
2. Clean the battery posts and/or adapters if necessary.
3. Install the battery post adapters, if needed.
4. Place the battery in the housing.
5. Verify that the controller master switch is in the OFF position.

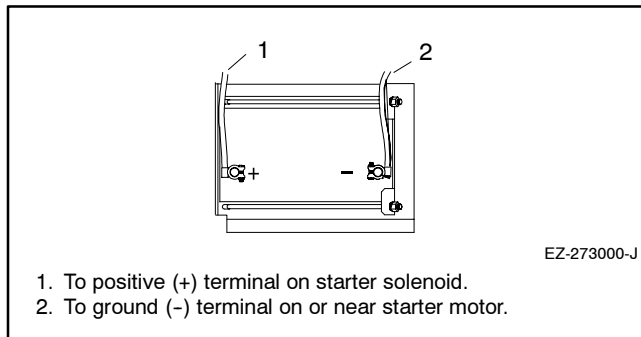

**Figure 6-15** 12-Volt Engine Electrical System Single Starter Motor Typical Battery Connection

6. Connect the positive (+) lead to the engine starting battery.
7. Connect the negative (-) lead to the engine starting battery.

Refer to Section 3.8 for battery maintenance instructions.

**6.9.5 Battery Charger**

The generator set requires an external battery charger to keep the starting battery fully charged. A 6-amp battery charger is factory-installed in the battery compartment. The battery charger’s DC leads are factory-connected.

Plug the battery charger’s power cord into a 120 VAC outlet on the load side of the system. Refer to Section 2.5 for battery charger operation information.

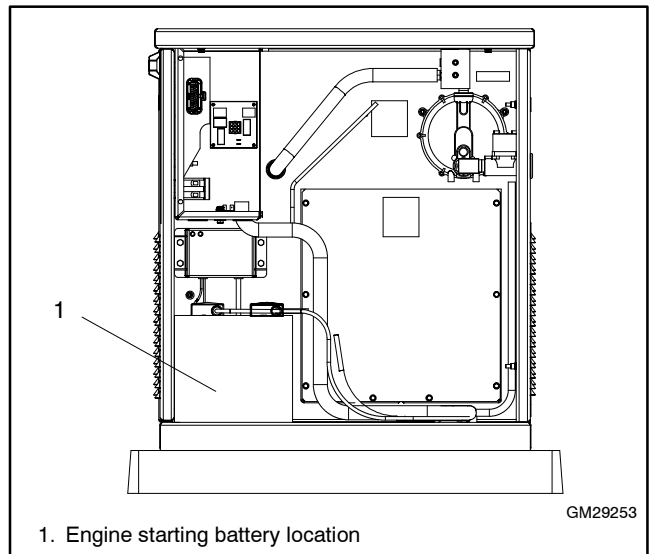

**Figure 6-16** Battery Location, Air Intake End

## 6.10 Accessories

Have accessories installed by an authorized distributor/dealer or a licensed electrician. Follow the installation instructions provided with each kit. Use separate conduit for AC and DC leads to reduce the possibility of electrical interference. Verify that the leads and conduit do not interfere with the operation of the generator set or obstruct the service areas. Verify that the electrical installation complies with the National Electrical Code (NEC) and all applicable local and state codes. See Section 5, Wiring Diagrams, for more information regarding generator set electrical connections.

### 6.10.1 Common Fault and Run Relay Board

The optional relay board provides two additional relays to control customer-provided equipment:

- Common fault relay
- Auxiliary run relay

The optional relay board replaces the standard relay board. The relay board location is shown in Figure 6-17. Connect customer equipment to the relay board harness. Figure 6-18 lists the customer connections.

The common fault relay is energized on a fault. The auxiliary run relay is energized when the generator set is running. Connect to each relay's normally open or normally closed contacts depending on the application.

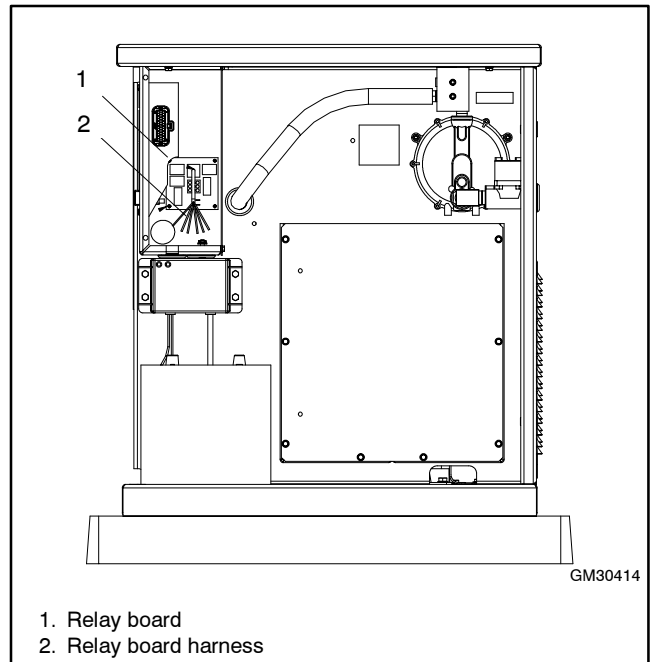

**Figure 6-17** Common Fault and Run Relay Board

Harness Lead Number	Connector Pin Number	Connection
88	6	Common fault normally open
89	2	Common fault common
90	3	Common fault normally closed
91	4	Run relay normally open
92	1	Run relay common
93	5	Run relay normally closed

**Figure 6-18** Common Fault and Run Relay Board Harness Connections

## 6.10.2 Carburetor Heater

An optional carburetor heater is recommended for improved cold starting in locations where the ambient temperature drops below 0°C (32 °F). The carburetor heater prevents condensation and carburetor icing. The heater turns on when the temperature at the thermostat falls below approximately 4°C (40°F) and turns off when the temperature rises above approximately 16°C (60°F).

The heater requires a continuous source of 120 VAC power. The heater power cord and thermostat are located in the generator set housing air intake area/battery compartment. See Figure 6-16. Plug the carburetor heater into an outlet that supplies continuous 120 VAC power.

The heater thermostat is installed in the cord. Figure 6-20 shows the location of the thermostat on the power cord.

**Note:** Do not place the heater thermostat inside the generator set engine compartment. The thermostat must be exposed to the ambient air. The thermostat will shut off power to the heater when the ambient temperature reaches approximately 60°F (16°C).

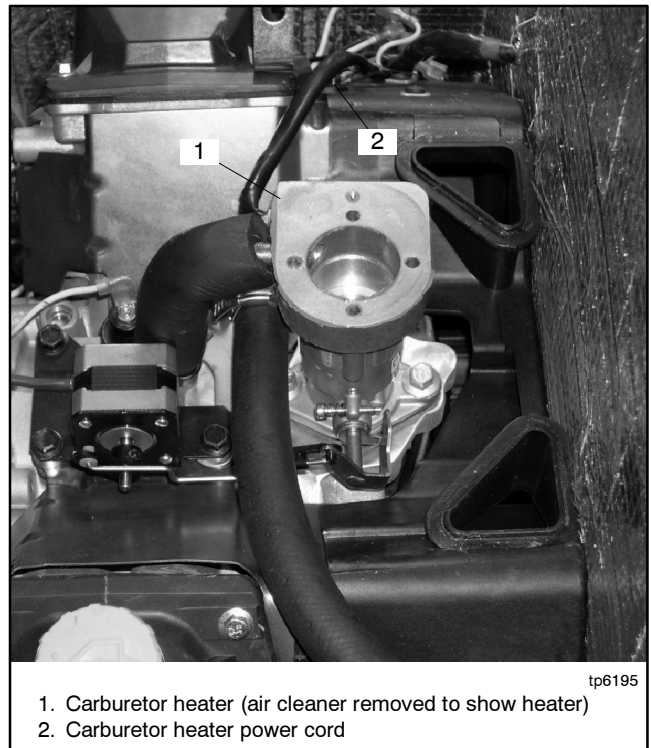

**Figure 6-19** Carburetor Heater

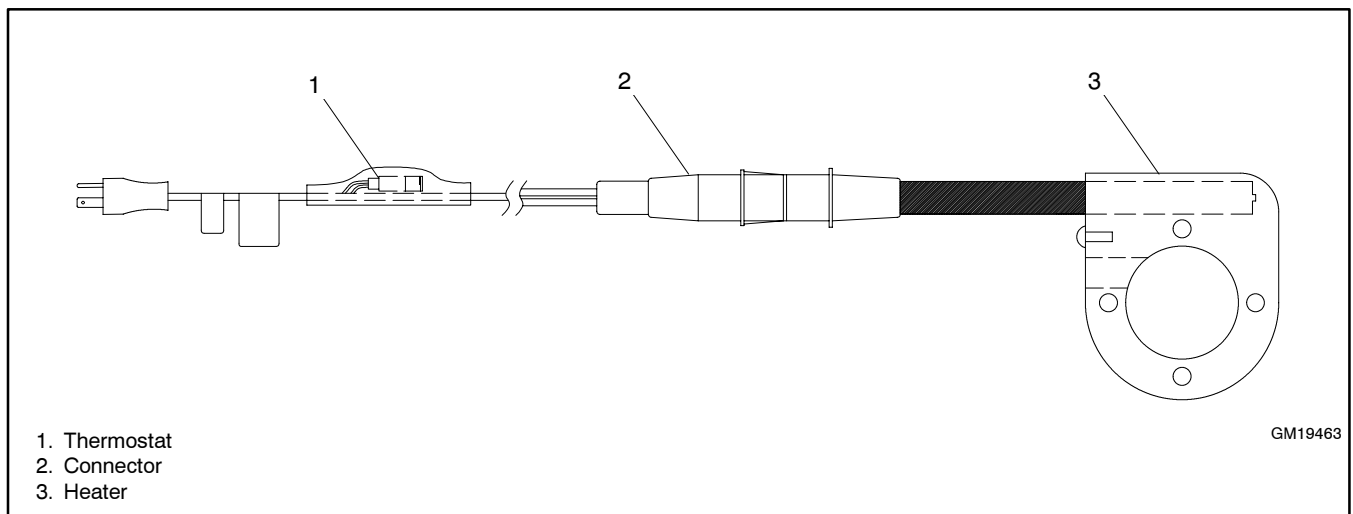

**Figure 6-20** Carburetor Heater with Thermostat

## 6.11 Controller Configuration

### 6.11.1 System Configuration

The system configuration is factory-set and should not normally require changes in the field. However, the controller's configuration modes allow setting of the system voltage/frequency and adjustment of the output voltage and frequency after reconnection. Have reconnection and the related adjustments performed by an authorized distributor/dealer or service technician.

The unit configuration and engine type are factory-set for each type of generator set and engine, and should not be changed in the field.

### 6.11.2 Advanced Configuration Mode

The controller's advanced configuration mode allows a technician to set the data input type for different senders, change the battery voltage to 12 or 24 VDC if the battery voltage is changed in the field, and change the controller communications setting for field-installed meters. Have these adjustments performed by an authorized distributor/dealer or service technician.

## 6.12 Prestart Installation Check

Review the entire installation section. Inspect all wiring and connections to verify that the generator set is ready for operation. Check that there are no obstructions to the air inlet and outlet. Check all items in the Prestart Checklist. See Section 2.1.

## 6.13 Warranty Registration

Complete the startup procedure and installation checklists supplied with the startup notification form. Return the form to the distributor/dealer or mail it directly to:

Kohler Power Systems  
Generator Warranty Administrator  
M.S. 072  
Kohler, Wisconsin 53044

# Notes

# Appendix A Abbreviations

The following list contains abbreviations that may appear in this publication.

A, amp	ampere	cfh	cubic feet per hour	est.	estimated
ABDC	after bottom dead center	cfm	cubic feet per minute	E-Stop	emergency stop
AC	alternating current	CG	center of gravity	etc.	et cetera (and so forth)
A/D	analog to digital	CID	cubic inch displacement	exh.	exhaust
ADC	analog to digital converter	CL	centerline	ext.	external
adj.	adjust, adjustment	cm	centimeter	F	Fahrenheit, female
ADV	advertising dimensional drawing	CMOS	complementary metal oxide substrate (semiconductor)	fglass.	fiberglass
AHWT	anticipatory high water temperature	cogen.	cogeneration	FHM	flat head machine (screw)
AISI	American Iron and Steel Institute	com	communications (port)	fl. oz.	fluid ounce
ALOP	anticipatory low oil pressure	coml	commercial	flex.	flexible
alt.	alternator	Coml/Rec	Commercial/Recreational	freq.	frequency
Al	aluminum	conn.	connection	FS	full scale
ANSI	American National Standards Institute (formerly American Standards Association, ASA)	cont.	continued	ft.	foot, feet
AO	anticipatory only	CPVC	chlorinated polyvinyl chloride	ft. lbs.	foot pounds (torque)
API	American Petroleum Institute	crit.	critical	ft./min.	feet per minute
approx.	approximate, approximately	CRT	cathode ray tube	g	gram
AR	as required, as requested	CSA	Canadian Standards Association	ga.	gauge (meters, wire size)
AS	as supplied, as stated, as suggested	CT	current transformer	gal.	gallon
ASE	American Society of Engineers	Cu	copper	gen.	generator
ASME	American Society of Mechanical Engineers	cu. in.	cubic inch	genset	generator set
assy.	assembly	cw.	clockwise	GFI	ground fault interrupter
ASTM	American Society for Testing Materials	CWC	city water-cooled	GND, ⊕	ground
ATDC	after top dead center	cyl.	cylinder	gov.	governor
ATS	automatic transfer switch	D/A	digital to analog	gph	gallons per hour
auto.	automatic	DAC	digital to analog converter	gpm	gallons per minute
aux.	auxiliary	dB	decibel	gr.	grade, gross
A/V	audiovisual	dBA	decibel (A weighted)	GRD	equipment ground
avg.	average	DC	direct current	gr. wt.	gross weight
AVR	automatic voltage regulator	DCR	direct current resistance	H x W x D	height by width by depth
AWG	American Wire Gauge	deg., °	degree	HC	hex cap
AWM	appliance wiring material	dept.	department	HCHT	high cylinder head temperature
bat.	battery	dia.	diameter	HD	heavy duty
BBDC	before bottom dead center	DI/EO	dual inlet/end outlet	HET	high exhaust temperature, high engine temperature
BC	battery charger, battery charging	DIN	Deutsches Institut fur Normung e. V. (also Deutsche Industrie Normenausschuss)	hex	hexagon
BCA	battery charging alternator	DIP	dual inline package	Hg	mercury (element)
BCI	Battery Council International	DPDT	double-pole, double-throw	HH	hex head
BDC	before dead center	DPST	double-pole, single-throw	HHC	hex head cap
BHP	brake horsepower	DS	disconnect switch	HP	horsepower
blk.	black (paint color), block (engine)	DSAM	digital spark-advance module	hr.	hour
blk. htr.	block heater	DVR	digital voltage regulator	HS	heat shrink
BMEP	brake mean effective pressure	E, emer.	emergency (power source)	hsg.	housing
bps	bits per second	EDI	electronic data interchange	HVAC	heating, ventilation, and air conditioning
br.	brass	EFR	emergency frequency relay	HWT	high water temperature
BTDC	before top dead center	e.g.	for example ( <i>exempli gratia</i> )	Hz	hertz (cycles per second)
Btu	British thermal unit	EG	electronic governor	IC	integrated circuit
Btu/min.	British thermal units per minute	EGSA	Electrical Generating Systems Association	ID	inside diameter, identification
C	Celsius, centigrade	EIA	Electronic Industries Association	IEC	International Electrotechnical Commission
cal.	calorie	EI/EO	end inlet/end outlet	IEEE	Institute of Electrical and Electronics Engineers
CARB	California Air Resources Board	EMI	electromagnetic interference	IMS	improved motor starting
CB	circuit breaker	emiss.	emission	in.	inch
cc	cubic centimeter	eng.	engine	in. H <sub>2</sub> O	inches of water
CCA	cold cranking amps	EPA	Environmental Protection Agency	in. Hg	inches of mercury
ccw.	counterclockwise	EPS	emergency power system	in. lbs.	inch pounds
CEC	Canadian Electrical Code	ER	emergency relay	Inc.	incorporated
cert.	certificate, certification, certified	ES	engineering special, engineered special	ind.	industrial
		ESD	electrostatic discharge	int.	internal

ISO	International Organization for Standardization	MS	military standard	RH	round head
J	joule	m/sec.	meters per second	RHM	round head machine (screw)
JIS	Japanese Industry Standard	MTBF	mean time between failure	rly.	relay
k	kilo (1000)	MTBO	mean time between overhauls	rms	root mean square
K	kelvin	mtg.	mounting	rnd.	round
kA	kiloampere	MW	megawatt	ROM	read only memory
KB	kilobyte (2 <sup>10</sup> bytes)	mW	milliwatt	rot.	rotate, rotating
kg	kilogram	μF	microfarad	rpm	revolutions per minute
kg/cm <sup>2</sup>	kilograms per square centimeter	N, norm.	normal (power source)	RS	right side
kgm	kilogram-meter	NA	not available, not applicable	RTV	room temperature vulcanization
kg/m <sup>3</sup>	kilograms per cubic meter	nat. gas	natural gas	SAE	Society of Automotive Engineers
kHz	kilohertz	NBS	National Bureau of Standards	scfm	standard cubic feet per minute
kJ	kilojoule	NC	normally closed	SCR	silicon controlled rectifier
km	kilometer	NEC	National Electrical Code	s, sec.	second
kOhm, kΩ	kilo-ohm	NEMA	National Electrical Manufacturers Association	SI	<i>Système international d'unites</i> , International System of Units
kPa	kilopascal	NFPA	National Fire Protection Association	SI/EO	side in/end out
kph	kilometers per hour	Nm	newton meter	sil.	silencer
kV	kilovolt	NO	normally open	SN	serial number
kVA	kilovolt ampere	no., nos.	number, numbers	SPDT	single-pole, double-throw
kVAR	kilovolt ampere reactive	NPS	National Pipe, Straight	SPST	single-pole, single-throw
kW	kilowatt	NPSC	National Pipe, Straight-coupling	spec, specs	specification(s)
kWh	kilowatt-hour	NPT	National Standard taper pipe thread per general use	sq.	square
kWm	kilowatt mechanical	NPTF	National Pipe, Taper-Fine	sq. cm	square centimeter
L	liter	NR	not required, normal relay	sq. in.	square inch
LAN	local area network	ns	nanosecond	SS	stainless steel
L x W x H	length by width by height	OC	overcrank	std.	standard
lb.	pound, pounds	OD	outside diameter	stl.	steel
lbm/ft <sup>3</sup>	pounds mass per cubic feet	OEM	original equipment manufacturer	tach.	tachometer
LCB	line circuit breaker	OF	overfrequency	TD	time delay
LCD	liquid crystal display	opt.	option, optional	TDC	top dead center
ld. shd.	load shed	OS	oversize, overspeed	TDEC	time delay engine cooldown
LED	light emitting diode	OSHA	Occupational Safety and Health Administration	TDEN	time delay emergency to normal
Lph	liters per hour	OV	overvoltage	TDES	time delay engine start
Lpm	liters per minute	oz.	ounce	TDNE	time delay normal to emergency
LOP	low oil pressure	p., pp.	page, pages	TDOE	time delay off to emergency
LP	liquefied petroleum	PC	personal computer	TDON	time delay off to normal
LPG	liquefied petroleum gas	PCB	printed circuit board	temp.	temperature
LS	left side	pF	picofarad	term.	terminal
L <sub>wa</sub>	sound power level, A weighted	PF	power factor	TIF	telephone influence factor
LWL	low water level	ph., ∅	phase	TIR	total indicator reading
LWT	low water temperature	PHC	Phillips head crimplite (screw)	tol.	tolerance
m	meter, milli (1/1000)	PHH	Phillips hex head (screw)	turbo.	turbocharger
M	mega (10 <sup>6</sup> when used with SI units), male	PHM	pan head machine (screw)	typ.	typical (same in multiple locations)
m <sup>3</sup>	cubic meter	PLC	programmable logic control	UF	underfrequency
m <sup>3</sup> /min.	cubic meters per minute	PMG	permanent-magnet generator	UHF	ultrahigh frequency
mA	milliampere	pot	potentiometer, potential	UL	Underwriter's Laboratories, Inc.
man.	manual	ppm	parts per million	UNC	unified coarse thread (was NC)
max.	maximum	PROM	programmable read-only memory	UNF	unified fine thread (was NF)
MB	megabyte (2 <sup>20</sup> bytes)	psi	pounds per square inch	univ.	universal
MCM	one thousand circular mils	pt.	pint	US	undersize, underspeed
MCCB	molded-case circuit breaker	PTC	positive temperature coefficient	UV	ultraviolet, undervoltage
meggar	megohmmeter	PTO	power takeoff	V	volt
MHz	megahertz	PVC	polyvinyl chloride	VAC	volts alternating current
mi.	mile	qt.	quart, quarts	VAR	voltampere reactive
mil	one one-thousandth of an inch	qty.	quantity	VDC	volts direct current
min.	minimum, minute	R	replacement (emergency) power source	VFD	vacuum fluorescent display
misc.	miscellaneous	rad.	radiator, radius	VGA	video graphics adapter
MJ	megajoule	RAM	random access memory	VHF	very high frequency
mJ	millijoule	RDO	relay driver output	W	watt
mm	millimeter	ref.	reference	WCR	withstand and closing rating
mOhm, mΩ	milliohm	rem.	remote	w/	with
MOhm, MΩ	megohm	Res/Coml	Residential/Commercial	w/o	without
MOV	metal oxide varistor	RFI	radio frequency interference	wt.	weight
MPa	megapascal			xfmr	transformer
mpg	miles per gallon				
mph	miles per hour				







**TP-6195 1/04**

© 2004 by Kohler Co. All rights reserved.

# **KOHLER**<sup>®</sup> POWER SYSTEMS

KOHLER CO. Kohler, Wisconsin 53044  
Phone 920-565-3381, Fax 920-459-1646  
For the nearest sales/service outlet in the  
US and Canada, phone 1-800-544-2444  
[KohlerPowerSystems.com](http://KohlerPowerSystems.com)

Kohler Power Systems  
Asia Pacific Headquarters  
7 Jurong Pier Road  
Singapore 619159  
Phone (65)264-6422, Fax (65)264-6455