

Service

Industrial Generator Sets

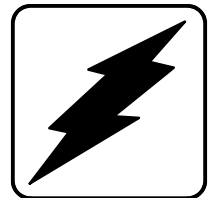

Models:

10RY/RZ/RFY/RFZ

12RY/RZ/RFY/RFZ

18RY/RZ/RFY/RFZ

Controllers:

Decision-Maker™ 3, 5-Light Relay



KOHLER[®]
POWER SYSTEMS

TP-5847 3/03b

Table of Contents

Product Identification Information	Inside front cover
Safety Precautions and Instructions	I
Introduction	i
Service Assistance	i
Section 1 Specifications	1
1.1 Introduction	1
1.2 Generator Features	1
1.3 Engine Features	1
1.4 Controllers	1
1.4.1 Controller Features	1
1.4.2 Relay Controller	1
1.4.3 5-Light Microprocessor Controller	2
1.5 Specifications	2
1.5.1 Engine Specifications	2
1.5.2 10-18RY/RFY Generator Specifications	3
1.5.3 10-18RZ/RFZ Generator Specifications	3
1.6 Service Views	4
1.7 Accessories	6
1.7.1 Overvoltage Kit (Microprocessor Controller)	6
1.7.2 Run Relay Kit	6
1.7.3 Audiovisual Alarm (Microprocessor Controller)	6
1.7.4 Remote Annunciator Kit (Microprocessor Controller)	7
1.7.5 Line Circuit Breaker	8
1.7.6 Remote Emergency Stop Kit (Microprocessor Controller)	8
1.7.7 Single-Relay Dry Contact Kit (Microprocessor Controller)	8
1.7.8 Ten-Relay Dry Contact Kit (Microprocessor Controller)	9
1.7.9 Accessory Connection (Microprocessor Controller)	9
Section 2 Scheduled Maintenance	11
2.1 Introduction	11
2.2 Service Schedule	12
2.3 Fuel System	14
2.3.1 Gasoline Fuel Specifications	14
2.3.2 Gasoline Fuel Filter Service	14
2.3.3 Gasoline Carburetor Adjustments	15
2.3.4 Gasoline Choke Adjustment	16
2.3.5 Gaseous Fuel Systems	17
2.3.6 LP Gas/Natural Gas Conversion, Gaseous Fuel System	17
2.3.7 Carburetor Adjustment, LP/Natural Gas	17
2.3.8 LP Liquid Withdrawal Fuel System	18
2.3.9 Manual Changeover Fuel System Kit 18 kW Gas/Gasoline Models ...	18
2.3.10 Automatic Changeover Fuel System Kit, 18 kW Gas Models	18
2.4 Air Cleaner Service	18
2.5 Crankcase Ventilation System	19
2.5.1 10/12 kW	19
2.5.2 18 kW	19
2.6 Cooling System	20
2.6.1 Theory of Operation	20
2.6.2 Wet Exhaust Manifold	22
2.6.3 Low Coolant Level (LCL) Shutdown	22
2.6.4 High Engine Temperature (HET) Shutdown	22
2.7 Drive Belts	23
2.8 Battery Maintenance	23
2.8.1 General	23

Table of Contents, continued

2.8.2	Cleaning	24
2.8.3	Electrolyte Level Check	24
2.8.4	Specific Gravity Check	24
2.8.5	Battery Charging	24
2.8.6	Battery Connection	25
2.9	Intake Manifold Bolt Torque, 10/12 kW	26
2.10	Generator Set Service	27
2.11	Wattage Requirements	27
2.12	Storage Procedure	27
2.12.1	Engine Oil	27
2.12.2	Fuel	27
2.12.3	Coolant	27
2.12.4	Cylinder Lubrication	27
2.12.5	Exterior Preparation	28
2.12.6	Battery	28
Section 3 General Troubleshooting		29
3.1	Engine Troubleshooting	29
3.2	Generator Troubleshooting	33
Section 4 Controller Troubleshooting		35
4.1	Relay Controller	35
4.1.1	Description	35
4.1.2	Sequence of Operation	35
4.1.3	Safety Shutdown Switches	36
4.1.4	Relay Controller Troubleshooting	37
4.1.5	Overspeed Shutdown	37
4.2	5-Light Microprocessor Controller	40
4.2.1	Introduction	40
4.2.2	5-Light Microprocessor Controller Circuit Board Components	42
4.2.3	Fault Shutdowns, 5-Light Microprocessor Controller	43
4.2.4	Relay Descriptions	43
4.2.5	Microprocessor Controller Troubleshooting	45
4.3	FastCheck	51
4.3.1	Features	51
4.3.2	Operation	52
Section 5 Component Testing and Adjustment		57
5.1	Theory of Operation, 1- and 3-Phase Generators with PowerBoost III E and V	58
5.2	Theory of Operation, 12-Lead (Brushless) Generators	58
5.3	Separate Excitation	59
5.3.1	4-Lead Generator Sets	59
5.3.2	12-Lead Generator Sets	60
5.4	Voltage Regulator	62
5.4.1	PowerBoost III and III E Voltage Regulator	62
5.4.2	PowerBoost V Voltage Regulator	65
5.5	Engine/Generator Components	69
5.5.1	Relay Controller	69
5.5.2	5-Light Microprocessor Controller	74
5.6	Fault Shutdown Test Procedure	76
5.6.1	Overspeed	76
5.6.2	Low Oil Pressure (LOP) Shutdown	76
5.6.3	Low Coolant Level (LCL) Shutdown	76
5.6.4	High Engine Temperature (HET) Shutdown	77
5.6.5	Overcrank Shutdown	77
5.7	Exciter Field, 10-18RZ/RFZ	77
5.8	Exciter Armature, 10-18RZ/RFZ	77

Table of Contents, continued

5.9	Rectifier Module, 10-18RZ/RFZ	78
5.10	Rotor (Main Field)	79
5.10.1	10-18RY/RFY	79
5.10.2	10-18RZ/RFZ	80
5.11	Stator	81
5.11.1	10-18RY/RFY	81
5.11.2	10-18RZ/RFZ	82
5.12	Brushes, 10-18RY/RFY	84
5.13	Magnetic Pickup, 10-18RY/RFY	85
5.14	Water Temperature and Oil Pressure Senders, if Equipped	86
5.15	Electronic Governor	86
5.15.1	Introduction	86
5.15.2	Electronic Governor (AC Sensing)	86
5.15.3	Electronic Governor (A-249922) Magnetic Pickup	89
5.15.4	Electronic Governor, Kohler Governor Magnetic Pickup	90
5.16	Cyclic Crank Board Test Procedure	93
Section 6 Disassembly/Reassembly		95
6.1	Disassembly	95
6.1.1	10/12RY/RFY	95
6.1.2	10/12RZ/RFZ	98
6.2	Reassembly	102
6.2.1	10/12RY/RFY	102
6.2.2	10/12RZ/RFZ	104
6.3	Disassembly, 18RY/RFY/RZ/RFZ	105
6.4	Reassembly, 18RY/RFY/RZ/RFZ	108
Section 7 Generator Reconnection		111
7.1	Voltage Reconnection	111
7.1.1	Four-Lead (Single-Phase) Generator Sets	111
7.1.2	100-120 Volt Configurations	112
7.1.3	100-120/200-240 Volt	112
7.1.4	200-240 Volt	112
7.1.5	12-Lead (3-Phase) Generator Sets	113
7.1.6	Reconnection Procedure (Microprocessor Controller only)	114
Appendix A Abbreviations		A-1
Appendix B Common Hardware Application Guidelines		A-3
Appendix C General Torque Specifications		A-4
Appendix D Common Hardware Identification		A-5
Appendix E Common Hardware List		A-6

Safety Precautions and Instructions

IMPORTANT SAFETY INSTRUCTIONS. Electromechanical equipment, including generator sets, transfer switches, switchgear, and accessories, can cause bodily harm and pose life-threatening danger when improperly installed, operated, or maintained. To prevent accidents be aware of potential dangers and act safely. Read and follow all safety precautions and instructions. **SAVE THESE INSTRUCTIONS.**

This manual has several types of safety precautions and instructions: Danger, Warning, Caution, and Notice.

DANGER

Danger indicates the presence of a hazard that **will cause severe personal injury, death, or substantial property damage.**

WARNING

Warning indicates the presence of a hazard that **can cause severe personal injury, death, or substantial property damage.**

CAUTION

Caution indicates the presence of a hazard that **will or can cause minor personal injury or property damage.**

NOTICE

Safety decals affixed to the equipment in prominent places alert the operator or service technician to potential hazards and explain how to act safely. The decals are shown throughout this publication to improve operator recognition. Replace missing or damaged decals.

Accidental Starting

WARNING

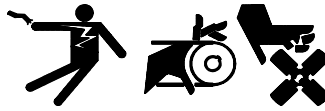

**Accidental starting.
Can cause severe injury or death.**

Disconnect the battery cables before working on the generator set. Remove the negative (-) lead first when disconnecting the battery. Reconnect the negative (-) lead last when reconnecting the battery.

Disabling the generator set. Accidental starting can cause severe injury or death. Before working on the generator set or connected equipment, disable the generator set as follows: (1) Move the generator set master switch to the OFF position. (2) Disconnect the power to the battery charger. (3) Remove the battery cables, negative (-) lead first. Reconnect the negative (-) lead last when reconnecting the battery. Follow these precautions to prevent starting of the generator set by an automatic transfer switch, remote start/stop switch, or engine start command from a remote computer.

Battery

WARNING



**Sulfuric acid in batteries.
Can cause severe injury or death.**

Wear protective goggles and clothing. Battery acid may cause blindness and burn skin.

WARNING



**Explosion.
Can cause severe injury or death.
Relays in the battery charger
cause arcs or sparks.**

Locate the battery in a well-ventilated area. Isolate the battery charger from explosive fumes.



Battery electrolyte is a diluted sulfuric acid. Battery acid can cause severe injury or death. Battery acid can cause blindness and burn skin. Always wear splashproof safety goggles, rubber gloves, and boots when servicing the battery. Do not open a sealed battery or mutilate the battery case. If battery acid splashes in the eyes or on the skin, immediately flush the affected area for 15 minutes with large quantities of clean water. Seek immediate medical aid in the case of eye contact. Never add acid to a battery after placing the battery in service, as this may result in hazardous spattering of battery acid.

Battery acid cleanup. Battery acid can cause severe injury or death. Battery acid is electrically conductive and corrosive. Add 500 g (1 lb.) of bicarbonate of soda (baking soda) to a container with 4 L (1 gal.) of water and mix the neutralizing solution. Pour the neutralizing solution on the spilled battery acid and continue to add the neutralizing solution to the spilled battery acid until all evidence of a chemical reaction (foaming) has ceased. Flush the resulting liquid with water and dry the area.

Battery gases. Explosion can cause severe injury or death. Battery gases can cause an explosion. Do not smoke or permit flames or sparks to occur near a battery at any time, particularly when it is charging. Do not dispose of a battery in a fire. To prevent burns and sparks that could cause an explosion, avoid touching the battery terminals with tools or other metal objects. Remove all jewelry before servicing the equipment. Discharge static electricity from your body before touching batteries by first touching a grounded metal surface away from the battery. To avoid sparks, do not disturb the battery charger connections while the battery is charging. Always turn the battery charger off before disconnecting the battery connections. Ventilate the compartments containing batteries to prevent accumulation of explosive gases.

Battery short circuits. Explosion can cause severe injury or death. Short circuits can cause bodily injury and/or equipment damage. Disconnect the battery before generator set installation or maintenance. Remove all jewelry before servicing the equipment. Use tools with insulated handles. Remove the negative (-) lead first when disconnecting the battery. Reconnect the negative (-) lead last when reconnecting the battery. Never connect the negative (-) battery cable to the positive (+) connection terminal of the starter solenoid. Do not test the battery condition by shorting the terminals together.

Engine Backfire/ Flash Fire



 WARNING

<p>Fire. Can cause severe injury or death.</p> <p>Do not smoke or permit flames or sparks near fuels or the fuel system.</p>

Servicing the fuel system. A flash fire can cause severe injury or death. Do not smoke or permit flames or sparks near the carburetor, fuel line, fuel filter, fuel pump, or other potential sources of spilled fuels or fuel vapors. Catch fuels in an approved container when removing the fuel line or carburetor.

Servicing the air cleaner. A sudden backfire can cause severe injury or death. Do not operate the generator set with the air cleaner removed.

Combustible materials. A fire can cause severe injury or death. Generator set engine fuels and fuel vapors are flammable and explosive. Handle these materials carefully to minimize the risk of fire or explosion. Equip the compartment or nearby area with a fully charged fire extinguisher. Select a fire extinguisher rated ABC or BC for electrical fires or as recommended by the local fire code or an authorized agency. Train all personnel on fire extinguisher operation and fire prevention procedures.

Exhaust System

 WARNING

<p>Carbon monoxide. Can cause severe nausea, fainting, or death.</p> <p>The exhaust system must be leakproof and routinely inspected.</p>

Generator set operation. Carbon monoxide can cause severe nausea, fainting, or death. Carbon monoxide is an odorless, colorless, tasteless, nonirritating gas that can cause death if inhaled for even a short time. Avoid breathing exhaust fumes when working on or near the generator set. Never operate the generator set inside a building unless the exhaust gas is piped safely outside. Never operate the generator set where exhaust gas could accumulate and seep back inside a potentially occupied building.

Carbon monoxide symptoms. Carbon monoxide can cause severe nausea, fainting, or death. Carbon monoxide is a poisonous gas present in exhaust gases. Carbon monoxide poisoning symptoms include but are not limited to the following:

- Light-headedness, dizziness
- Physical fatigue, weakness in joints and muscles
- Sleepiness, mental fatigue, inability to concentrate or speak clearly, blurred vision
- Stomachache, vomiting, nausea

If experiencing any of these symptoms and carbon monoxide poisoning is possible, seek fresh air immediately and remain active. Do not sit, lie down, or fall asleep. Alert others to the possibility of carbon monoxide poisoning. Seek medical attention if the condition of affected persons does not improve within minutes of breathing fresh air.

Fuel System

⚠ WARNING

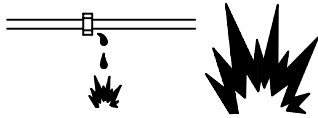

Explosive fuel vapors. Can cause severe injury or death.

Use extreme care when handling, storing, and using fuels.

The fuel system. Explosive fuel vapors can cause severe injury or death. Vaporized fuels are highly explosive. Use extreme care when handling and storing fuels. Store fuels in a well-ventilated area away from spark-producing equipment and out of the reach of children. Never add fuel to the tank while the engine is running because spilled fuel may ignite on contact with hot parts or from sparks. Do not smoke or permit flames or sparks to occur near sources of spilled fuel or fuel vapors. Keep the fuel lines and connections tight and in good condition. Do not replace flexible fuel lines with rigid lines. Use flexible

sections to avoid fuel line breakage caused by vibration. Do not operate the generator set in the presence of fuel leaks, fuel accumulation, or sparks. Repair fuel systems before resuming generator set operation.

Explosive fuel vapors can cause severe injury or death. Take additional precautions when using the following fuels:

Gasoline—Store gasoline only in approved red containers clearly marked GASOLINE.

Propane (LP)—Adequate ventilation is mandatory. Because propane is heavier than air, install propane gas detectors low in a room. Inspect the detectors per the manufacturer's instructions.

Natural Gas—Adequate ventilation is mandatory. Because natural gas rises, install natural gas detectors high in a room. Inspect the detectors per the manufacturer's instructions.

Fuel tanks. Explosive fuel vapors can cause severe injury or death. Gasoline and other volatile fuels stored in day tanks or subbase fuel tanks can cause an explosion. Store only diesel fuel in tanks.

Draining the fuel system. Explosive fuel vapors can cause severe injury or death. Spilled fuel can cause an explosion. Use a container to catch fuel when draining the fuel system. Wipe up spilled fuel after draining the system.

Gas fuel leaks. Explosive fuel vapors can cause severe injury or death. Fuel leakage can cause an explosion. Check the LP vapor gas or natural gas fuel system for leakage by using a soap and water solution with the fuel system test pressurized to 6–8 ounces per square inch (10–14 inches water column). Do not use a soap solution containing either ammonia or chlorine because both prevent bubble formation. A successful test depends on the ability of the solution to bubble.

LP liquid withdrawal fuel leaks. Explosive fuel vapors can cause severe injury or death. Fuel leakage can cause an explosion. Check the LP liquid withdrawal gas fuel system for leakage by using a soap and water solution with the fuel system test pressurized to at least 90 psi (621 kPa). Do not use a soap solution containing either ammonia or chlorine because both prevent bubble formation. A successful test depends on the ability of the solution to bubble.

Hazardous Noise

⚠ CAUTION



Hazardous noise.
Can cause hearing loss.

Never operate the generator set without a muffler or with a faulty exhaust system.

Engine noise. Hazardous noise can cause hearing loss. Generator sets not equipped with sound enclosures can produce noise levels greater than 105 dBA. Prolonged exposure to noise levels greater than 85 dBA can cause permanent hearing loss. Wear hearing protection when near an operating generator set.

Hazardous Voltage/ Electrical Shock

⚠ WARNING

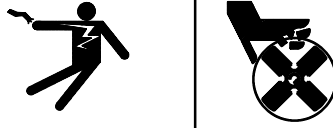

Hazardous voltage. Moving rotor.
Can cause severe injury or death.

Operate the generator set only when all guards and electrical enclosures are in place.

⚠ WARNING



Hazardous voltage.
Backfeed to the utility system can cause property damage, severe injury, or death.

If the generator set is used for standby power, install an automatic transfer switch to prevent inadvertent interconnection of standby and normal sources of supply.

⚠ CAUTION



Welding the generator set.
Can cause severe electrical equipment damage.

Never weld components of the generator set without first disconnecting the battery, controller wiring harness, and engine electronic control module (ECM).

Grounding electrical equipment. Hazardous voltage can cause severe injury or death. Electrocutation is possible whenever electricity is present. Open the main circuit breakers of all power sources before servicing the equipment. Configure the installation to electrically ground the generator set, transfer switch, and related equipment and electrical circuits to comply with applicable codes and standards. Never contact electrical leads or appliances when standing in water or on wet ground because these conditions increase the risk of electrocution.

Disconnecting the electrical load. Hazardous voltage can cause severe injury or death. Disconnect the generator set from the load by opening the line circuit breaker or by disconnecting the generator set output leads from the transfer switch and heavily taping the ends of the leads. High voltage transferred to the load during testing may cause personal injury and equipment damage. Do not use the safeguard circuit breaker in place of the line circuit breaker. The safeguard circuit breaker does not disconnect the generator set from the load.

Welding the generator set. Can cause severe electrical equipment damage. Before welding the generator set perform the following steps: (1) Remove the battery cables, negative (-) lead first. (2) Disconnect all engine electronic control module (ECM) connectors. (3) Disconnect all generator set controller and voltage regulator circuit board connectors. (4) Disconnect the engine battery-charging alternator connections. (5) Attach the weld ground connection close to the weld location.

Installing the battery charger. Hazardous voltage can cause severe injury or death. An ungrounded battery charger may cause electrical shock. Connect the battery charger enclosure to the ground of a permanent wiring system. As an alternative, install an equipment grounding conductor with circuit conductors and connect it to the equipment grounding terminal or the lead on the battery charger. Install the battery charger as prescribed in the equipment manual. Install the battery charger in compliance with local codes and ordinances.

Connecting the battery and the battery charger. Hazardous voltage can cause severe injury or death. Reconnect the battery correctly, positive to positive and negative to negative, to avoid electrical shock and damage to the battery charger and battery(ies). Have a qualified electrician install the battery(ies).

Short circuits. Hazardous voltage/current can cause severe injury or death. Short circuits can cause bodily injury and/or equipment damage. Do not contact electrical connections with tools or jewelry while making adjustments or repairs. Remove all jewelry before servicing the equipment.



Testing the voltage regulator. Hazardous voltage can cause severe injury or death. High voltage is present at the voltage regulator heat sink. To prevent electrical shock do not touch the voltage regulator heat sink when testing the voltage regulator. *(PowerBoost™, PowerBoost™ III, and PowerBoost™ V voltage regulator models only)*

Engine block heater. Hazardous voltage can cause severe injury or death. The engine block heater can cause electrical shock. Remove the engine block heater plug from the electrical outlet before working on the block heater electrical connections.



Electrical backfeed to the utility. Hazardous backfeed voltage can cause severe injury or death. Install a transfer switch in standby power installations to prevent the connection of standby and other sources of power. Electrical backfeed into a utility electrical system can cause severe injury or death to utility personnel working on power lines.



Testing live electrical circuits. Hazardous voltage or current can cause severe injury or death. Have trained and qualified personnel take diagnostic measurements of live circuits. Use adequately rated test equipment with electrically insulated probes and follow the instructions of the test equipment manufacturer when performing voltage tests. Observe the following precautions when performing voltage tests: (1) Remove all jewelry. (2) Stand on a dry, approved electrically insulated mat. (3) Do not touch the enclosure or components inside the enclosure. (4) Be prepared for the system to operate automatically. *(600 volts and under)*

Heavy Equipment

 WARNING

<p>Unbalanced weight. Improper lifting can cause severe injury or death and equipment damage.</p> <p>Do not use lifting eyes. Lift the generator set using lifting bars inserted through the lifting holes on the skid.</p>

Hot Parts

 WARNING

<p>Hot coolant and steam. Can cause severe injury or death.</p> <p>Before removing the pressure cap, stop the generator set and allow it to cool. Then loosen the pressure cap to relieve pressure.</p>



 WARNING

<p>Hot engine and exhaust system. Can cause severe injury or death.</p> <p>Do not work on the generator set until it cools.</p>



Servicing the generator. Hot parts can cause severe injury or death. Avoid touching the generator set field or exciter armature. When shorted, the generator set field and exciter armature become hot enough to cause severe burns.

Checking the coolant level. Hot coolant can cause severe injury or death. Allow the engine to cool. Release pressure from the cooling system before removing the pressure cap. To release pressure, cover the pressure cap with a thick cloth and then slowly turn the cap counterclockwise to the first stop. Remove the cap after pressure has been completely released and the engine has cooled. Check the coolant level at the tank if the generator set has a coolant recovery tank.

Servicing the exhaust system. Hot parts can cause severe injury or death. Do not touch hot engine parts. The engine and exhaust system components become extremely hot during operation.

Moving Parts

⚠ WARNING	
	
Hazardous voltage. Moving rotor. Can cause severe injury or death.	
Operate the generator set only when all guards and electrical enclosures are in place.	

⚠ WARNING	
	
Rotating parts. Can cause severe injury or death.	
Operate the generator set only when all guards, screens, and covers are in place.	

⚠ WARNING	
	
Airborne particles. Can cause severe injury or blindness.	
Wear protective goggles and clothing when using power tools, hand tools, or compressed air.	

Tightening the hardware. Flying projectiles can cause severe injury or death. Loose hardware can cause the hardware or pulley to release from the generator set engine and can cause personal injury. Retorque all crankshaft and rotor hardware after servicing. Do not loosen the crankshaft hardware or rotor throbolt when making adjustments or servicing the generator set. Rotate the crankshaft manually in a clockwise direction only. Turning the crankshaft bolt or rotor throbolt counterclockwise can loosen the hardware.

Servicing the generator set when it is operating. Exposed moving parts can cause severe injury or death. Keep hands, feet, hair, clothing, and test leads away from the belts and pulleys when the generator set is running. Replace guards, screens, and covers before operating the generator set.

Notice

NOTICE	
This generator set has been rewired from its nameplate voltage to	
	
<small>246242</small>	

NOTICE

Voltage reconnection. Affix a notice to the generator set after reconnecting the set to a voltage different from the voltage on the nameplate. Order voltage reconnection decal 246242 from an authorized service distributor/dealer.

NOTICE

Hardware damage. The engine and generator set may use both American Standard and metric hardware. Use the correct size tools to prevent rounding of the bolt heads and nuts.

NOTICE

When replacing hardware, do not substitute with inferior grade hardware. Screws and nuts are available in different hardness ratings. To indicate hardness, American Standard hardware uses a series of markings, and metric hardware uses a numeric system. Check the markings on the bolt heads and nuts for identification.

NOTICE

Canadian installations only. For standby service connect the output of the generator set to a suitably rated transfer switch in accordance with Canadian Electrical Code, Part 1.

This manual covers the maintenance, troubleshooting, and repair of 10/12/18RY, 10/12/18RFY, 10/12/18RZ, and 10/12/18RFZ Industrial generator sets equipped with a relay controller or Decision-Maker™ 3, 5-light microprocessor controller. Refer to the generator set operation manual for operating procedures.

This manual may also be used for similar models not listed on the front cover.

Information in this publication represents data available at the time of print. Kohler Co. reserves the right to change this publication and the products represented without notice and without any obligation or liability whatsoever.

Read this manual and carefully follow all procedures and safety precautions to ensure proper equipment operation and to avoid bodily injury. Read and follow the Safety Precautions and Instructions section at the beginning of this manual. Keep this manual with the equipment for future reference.

The equipment service requirements are very important to safe and efficient operation. Inspect the parts often and perform required service at the prescribed intervals. Maintenance work must be performed by appropriately skilled and suitably trained maintenance personnel familiar with generator set operation and service.

Service Assistance

For professional advice on generator power requirements and conscientious service, please contact your nearest Kohler distributor or dealer.

- Consult the Yellow Pages under the heading Generators—Electric
- Visit the Kohler Power Systems website at KohlerPowerSystems.com
- Look at the labels and stickers on your Kohler product or review the appropriate literature or documents included with the product
- Call toll free in the US and Canada 1-800-544-2444
- Outside the US and Canada, call the nearest regional office

Africa, Europe, Middle East

London Regional Office
Langley, Slough, England
Phone: (44) 1753-580-771
Fax: (44) 1753-580-036

Asia Pacific

Power Systems Asia Pacific Regional Office
Singapore, Republic of Singapore
Phone: (65) 264-6422
Fax: (65) 264-6455

China

North China Regional Office, Beijing
Phone: (86) 10 6518 7950
(86) 10 6518 7951
(86) 10 6518 7952
Fax: (86) 10 6518 7955

East China Regional Office, Shanghai
Phone: (86) 21 6288 0500
Fax: (86) 21 6288 0550

India, Bangladesh, Sri Lanka

India Regional Office
Bangalore, India
Phone: (91) 80 3366208
(91) 80 3366231
Fax: (91) 80 3315972

Japan, Korea

North Asia Regional Office
Tokyo, Japan
Phone: (813) 3440-4515
Fax: (813) 3440-2727

Latin America

Latin America Regional Office
Lakeland, Florida, USA
Phone: (863) 619-7568
Fax: (863) 701-7131

X:in:008:001a

Notes

1.1 Introduction

Service requirements are minimal but are very important to the safe and efficient operation of the generator set; therefore, inspect associated parts often.

Keep this manual with the generator set for future reference. Refer to Figure 1-1 or Figure 1-2 for identification and location of components.

The spec sheets for each generator set provide specific generator and engine information. Refer to the respective spec sheet for data not supplied in this manual. Consult the generator set operation manual, installation manual, engine operation manual, and engine service manual for additional specifications.

1.2 Generator Features

- Static excited, rotating field design permits power to be obtained from stationary leads.
- Rotor and stator are vacuum impregnated with high bond epoxy varnish which helps insulation breakdown in high humidity areas.
- Dynamically balanced rotor minimizes vibration.
- Copper windings ensure minimal heat buildup. Insulation meets NEMA standards for Class 155 insulation.
- Direct connected to the engine, the generator has sealed precision ball bearing with end bearing mounted in a cast metal sleeve to prevent shaft misalignment and extend bearing life.
- Voltage regulation ($\pm 2\%$ no load to full load transient) and frequency regulation ($\pm 0.5\%$ no load to full load transient) prevents prolonged operation at severe under- or overvoltage conditions which could damage appliances.
- Generator is self-ventilated and has drip-proof construction.
- Four-lead reconnectable stator (1-phase models).
- Twelve-lead reconnectable.

Note: DERATING: The kilowatts of the generator set will decrease 4% for each 305 m (1000 ft.) above sea level and 1% for each 5.5°C (10°F) increase in ambient temperature above 16°C (60°F), and 11.1% when converted to LP fuel.

1.3 Engine Features

Ford inline four-cylinder, watercooled, four-cycle, gasoline engines (LP and natural gas-powered configurations available).

- 10RY/RFY—Ford VSG-411
- 12RY/RFY—Ford VSG-413
- 18RY/RFY—Ford LRG-423

The engine features are listed below:

- One-side serviceability, air cleaner, carburetor, oil fill, dipstick, and oil drain.
- Internally vented crankcase breathers reduce emissions of unburned hydrocarbons.
- Operates on leaded or unleaded fuel with octane rating of 86 or higher.
- Engine shutdown control prevents dieseling on shutdown.
- Low oil pressure cutout shuts engine down to prevent failure.
- Electronic ignition provides efficient operation with less maintenance than mechanical systems.
- Electronic governor provides faster frequency response to load changes and tighter steady state frequency regulation.
- Anti-icing Module prevents moisture freezing in fuel delivery system.
- Overspeed shutdown prevents governed frequency from exceeding 70 Hz.

1.4 Controllers

1.4.1 Controller Features

The generator set is equipped with either a relay controller or a 5-light microprocessor controller. For a specific description of the controller, see Section 2, Operation, in the operation manual. Controller features include the following:

1.4.2 Relay Controller

- Fault shutdowns with common indicator:
 - Level, low coolant

- Overcrank
- Overspeed
- Pressure, low oil
- Temperature, high engine
- Running time meter
- Switches and standard features:
 - Cranking, cyclic
 - Start, remote two-wire
 - Switch, run/off-reset/auto (engine start)

1.4.3 5-Light Microprocessor Controller

- Analog gauges, 51 mm (2 in.), 2% full-accuracy:
 - Pressure gauge, oil
 - Temperature gauge, engine water
 - Voltmeter, DC only
- Analog meters, 89 mm (3.5 in.):
 - AC ammeter, 2% full-scale accuracy
 - AC voltmeter, 2% full-scale accuracy
 - Frequency meter, 0.5% full-scale accuracy
- Fault shutdowns and status indicators:
 - Auxiliary (red)
 - Level, low coolant (uses auxiliary fault indicator)
 - Overcrank (red)
 - Overspeed (red)
 - Pressure, low oil (red)
 - Temperature, high engine (red)
 - Temperature, low water (red)*
- Running time meter
- Switches and standard features:
 - Cranking, cyclic
 - Horn, alarm (with silence switch)
 - Rheostat, generator output voltage-adjusting (front panel mounted, $\pm 5\%$ of nominal voltage)
 - Start, remote two-wire
 - Switch, lamp test
 - Switch, meter range selector
 - Switch, run/off-reset/auto (engine start)
 - Timer, engine cool down (5-minute fixed)

* Requires optional kit or user-provided device for lamp to function.

1.5 Specifications

1.5.1 Engine Specifications

Engine	
Engine Prealarm and Shutdown Switches	Specification
Anticipatory high engine temperature switch	121 \pm 4°C (250 \pm 7°F)
Anticipatory low oil pressure switch	138 kPa \pm 14 kPa (20 psi \pm 2)
High engine temperature shutdown switch	103 \pm 4°C (218 \pm 7°F)
Low oil pressure shutdown switch	103 kPa \pm 14 kPa (15 psi \pm 2)
Controller Gauge Senders	Specification, ohms
Oil Pressure Sender	
0 kPa (0 psi)	240 \pm 10%
345 kPa (50 psi)	103 \pm 10%
690 kPa (100 psi)	33 \pm 10%
Water Temperature Sender	
38°-116° or 38°-120°C	33
100°-240°F or 100°-250°F	450

1.5.2 10-18RY/RFY Generator Specifications

Generator						
Component Specification	Value					
	10RY	10RFY	12RY	12RFY	18RY	18RFY
Controller/battery electrical system	12 volts DC					
Overbolt torque, Nm (in. lb.)	6.8 (60)				24.4 (216)	
Rotor resistance ohms (cold)	3.9		2.8			
Stator resistance ohms (cold)						
Leads:						
1-2, 3-4	0.09	0.09	0.06	0.06	0.05	0.05
33-44	0.09	0.09	0.06	0.06	0.05	0.05
55-33	1.3	1.3	1.1	1.1	1.1	1.1
Stator output voltages with separately excited rotor using 12-volt battery						
1-2, 3-4	100	N/A	90	N/A	90	N/A
55-66	150	N/A	140	N/A	140	N/A
Rotor field voltage/current readings at rated output voltage (hot) (240 V/60 Hz 1.0 PF)						
No load	17/3.9	N/A	17/3.9	N/A	17/3.9	N/A
Full load	41/7.2	N/A	41/7.2	N/A	41/7.2	N/A

1.5.3 10-18RZ/RFZ Generator Specifications

Generator						
Component Specification	Value					
	10RZ	10RFZ	12RZ	12RFZ	18RZ	18RFZ
Controller/battery electrical system	12 volts DC					
Overbolt torque, Nm (in. lb.)	24.4 (216)					
Exciter field voltage/current readings at rated voltage (hot) (208V, 50 Hz, 0.8 PF)						
12-lead generator:						
No load (63 Hz)	6.5/1.2	15/2.3	10/1.8	28/2.4	10/1.8	28/2.4
Full Load (60 Hz)	17/3.0	30/4.5	20/3.5	34/4.9	45/6.0	57/6.9
6-lead generator:						
No load	6.5/1.2	6.5/1.2	10/1.8	10/1.8	10/1.8	10/1.8
Full Load	17/3.0	17/3.0	20/3.5	20/3.5	45/6.0	45/6.0
Exciter field resistance ohms (cold)	4.5				5.0	
Exciter armature resistance ohms (cold)	0.7					
Main field (rotor) resistance ohms (cold)	6.7		7.8		7.8	
Stator output voltages with separately excited generator, using 12-volt battery						
12-lead stator:						
1-4, 2-5, 3-6, 7-10, 8-11, 9-12	210	175	170	140	170	140
55-66	230	190	180	150	180	150
6-lead stator:						
1-4, 2-5, 3-6	350	290	300	250	300	250
55-66	230	190	180	150	180	150
Stator resistance ohms (cold)						
12-lead stator:						
1-4, 2-5, 3-6, 7-10, 8-11, 9-12	0.19	0.19	0.17	0.17	0.04	0.04
55-66	1.4	1.4	1.3	1.3	1.3	1.3
6-lead stator:						
1-4, 2-5, 3-6	0.6		0.5		0.5	
55-66	1.4		1.3		1.3	

1.6 Service Views

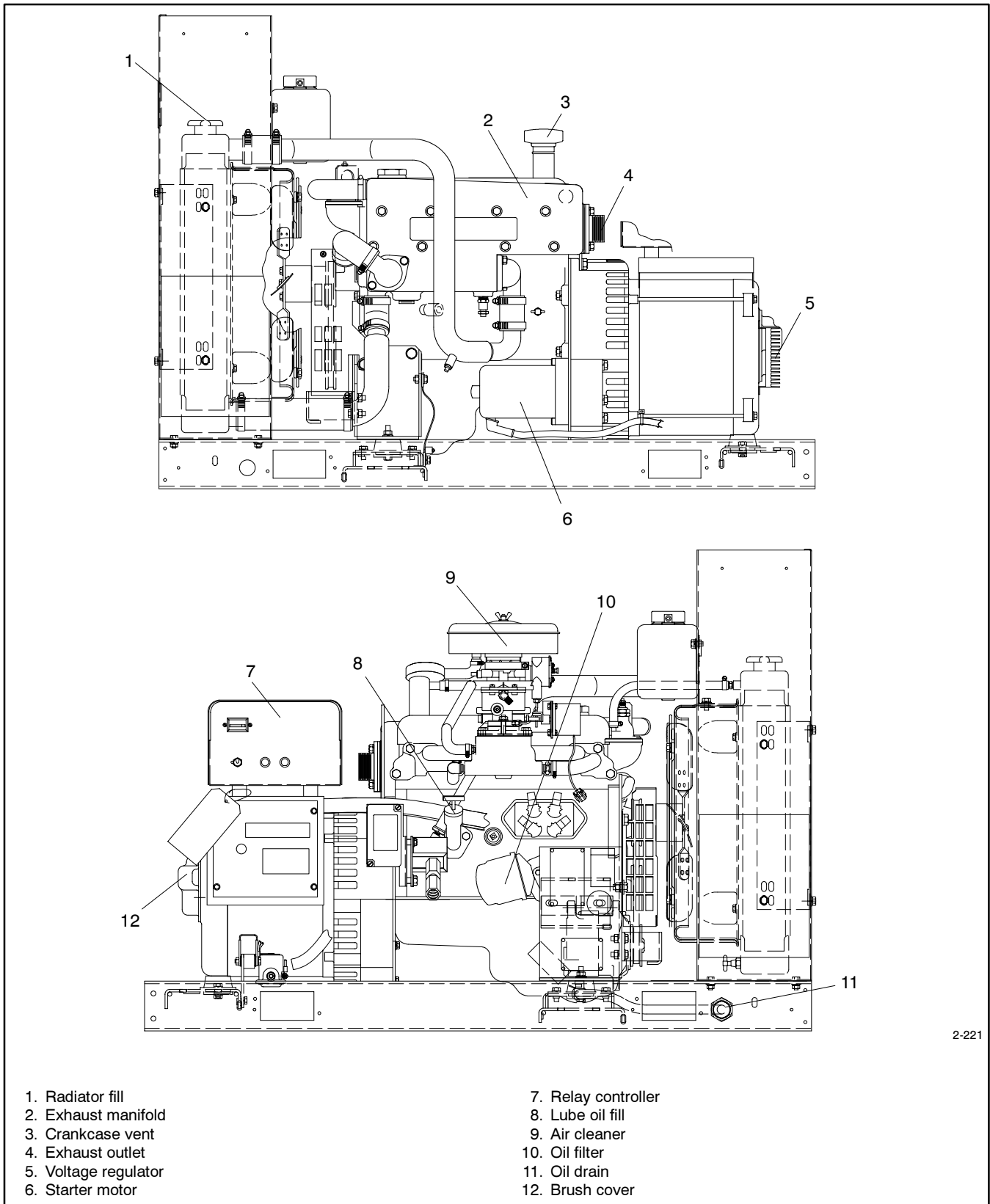

2-221

Figure 1-1 Service Views, 10RY/RFY and 12RY/RFY (4-Lead) Generator Set

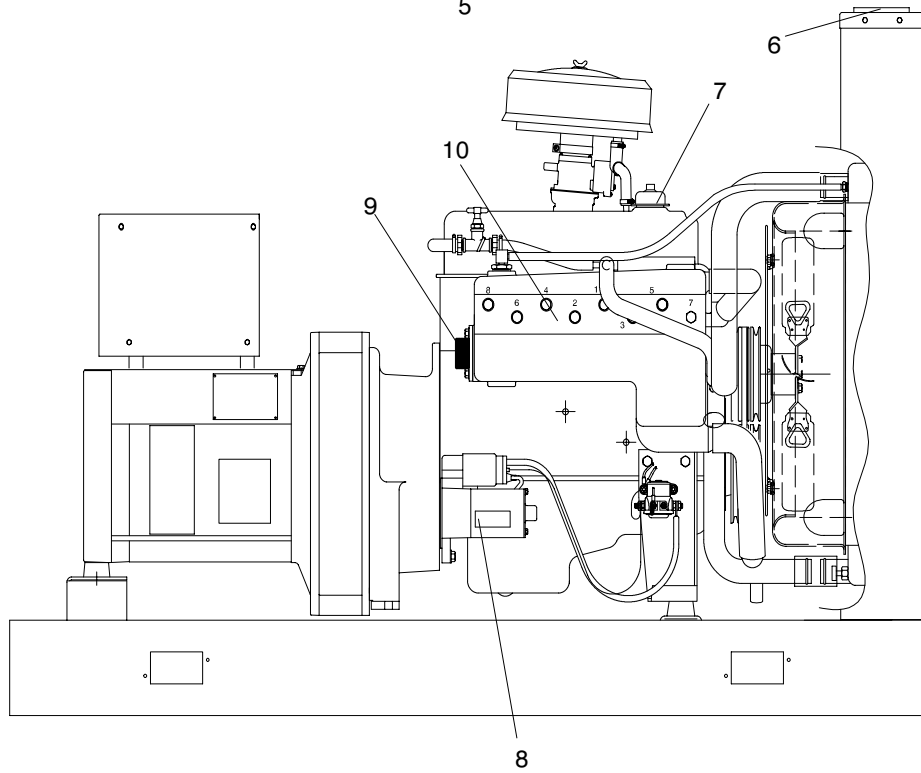
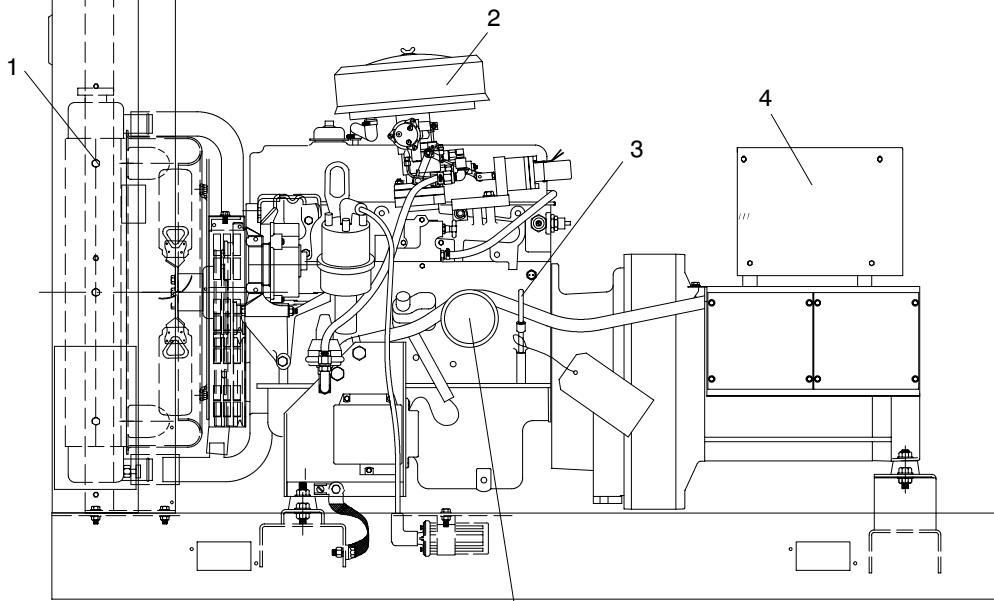

HX-255000

- | | |
|--------------------------------------|----------------------|
| 1. Cooling system | 6. Radiator fill |
| 2. Air cleaner | 7. Oil fill |
| 3. Oil level dipstick | 8. Starter motor |
| 4. 5-light microprocessor controller | 9. Exhaust outlet |
| 5. Oil filter | 10. Exhaust manifold |

Figure 1-2 Service Views, 18RY/RFY (4-Lead) Generator Sets

1.7.4 Remote Annunciator Kit (Microprocessor Controller)

The remote annunciator allows convenient monitoring of the generator set's condition from a remote location. The remote annunciator kit is available in surface mount and flush mount. A ten-relay dry contact kit is included with this kit. See Figure 1-6. The remote annunciator includes alarm horn, alarm silence switch, lamp test, and the same lamp indicators as the 5-light microprocessor controller, plus the following:

Line Power Lamp. Lamp lights when commercial utility power is in use.

Generator Power Lamp. Lamp lights when generator set power is in use.

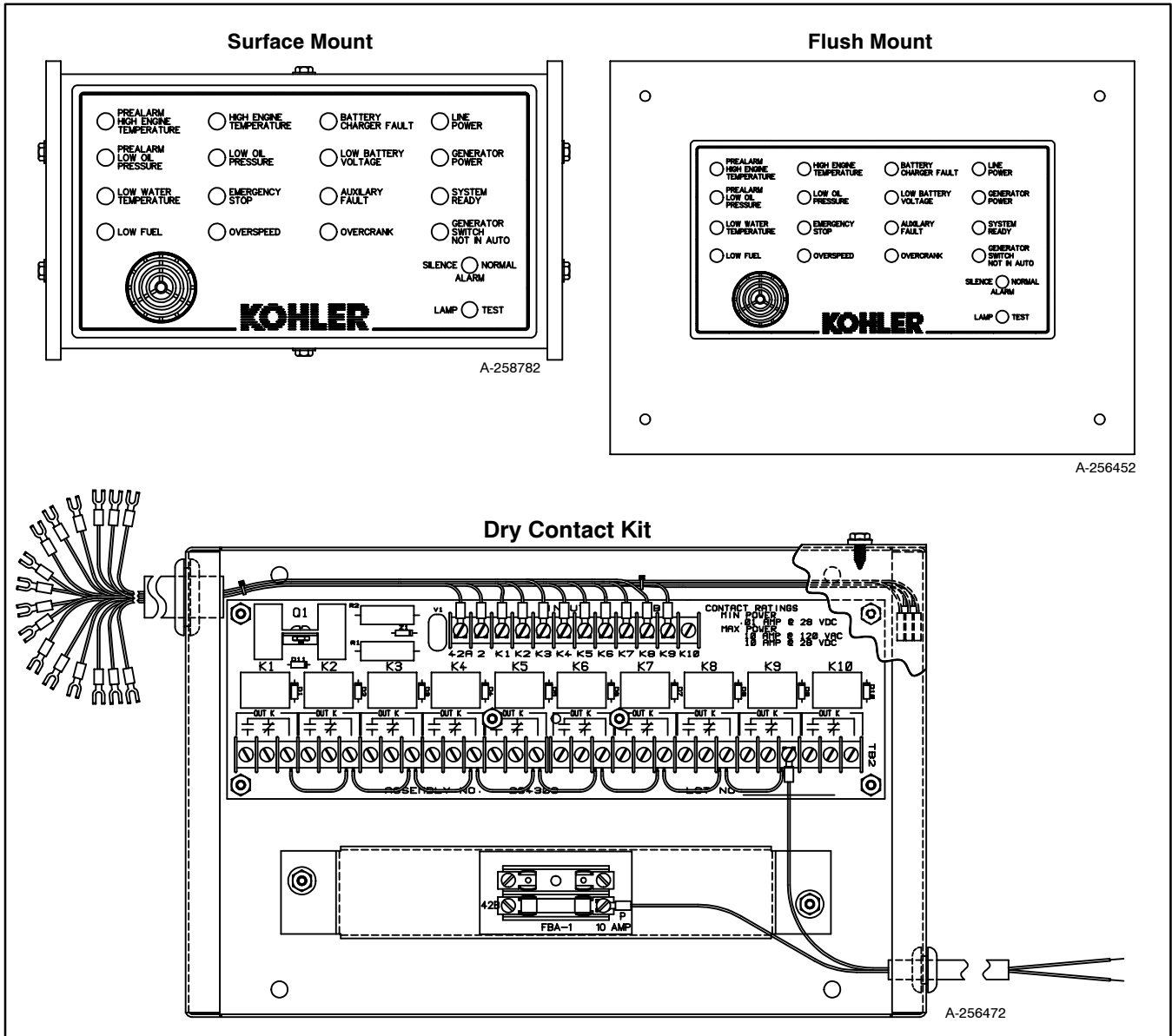

Figure 1-6 Remote Annunciator

1.7.5 Line Circuit Breaker

The line circuit breaker interrupts generator output in the event of an overload or short circuit in the wiring between the alternator and components. Use the line circuit breaker to manually disconnect the generator set from the load when servicing the generator set. See Figure 1-7.

1.7.6 Remote Emergency Stop Kit (Microprocessor Controller)

The emergency stop kit allows immediate shutdown of the generator set from a remote location. See Figure 1-8. The emergency stop lamp lights and the generator set shuts down if the emergency stop switch is activated. The generator set cannot be restarted until the emergency stop switch is reset (by replacing glass piece) and the controller is reset by placing generator set master switch in the OFF/RESET position.

1.7.7 Single-Relay Dry Contact Kit (Microprocessor Controller)

The single-relay dry contact kit uses one set of relay contacts to trigger customer-provided warning devices if a fault condition occurs. See Figure 1-9. A wiring harness included with the kit links the relay kit with the controller terminal strip or controller connection kit. Refer to the accessory wiring diagram for correct connection of the single-relay dry contact kit wiring harness. Connect the single-relay dry contact kit to any controller fault output (on TB1 terminal strip). Typical connections include:

- Emergency Stop
- Auxiliary
- Overspeed
- Low Oil Pressure
- High Engine Temperature

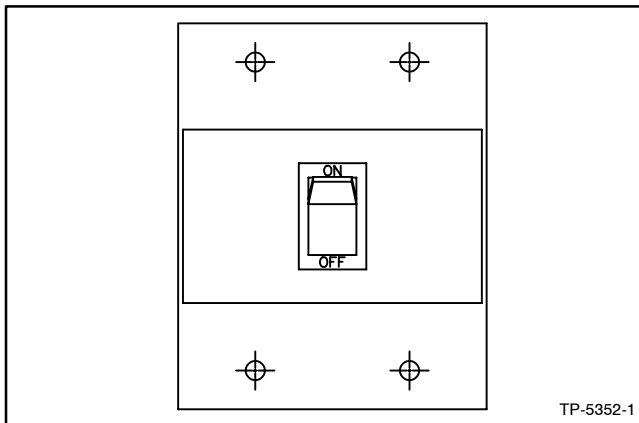

Figure 1-7 Line Circuit Breaker

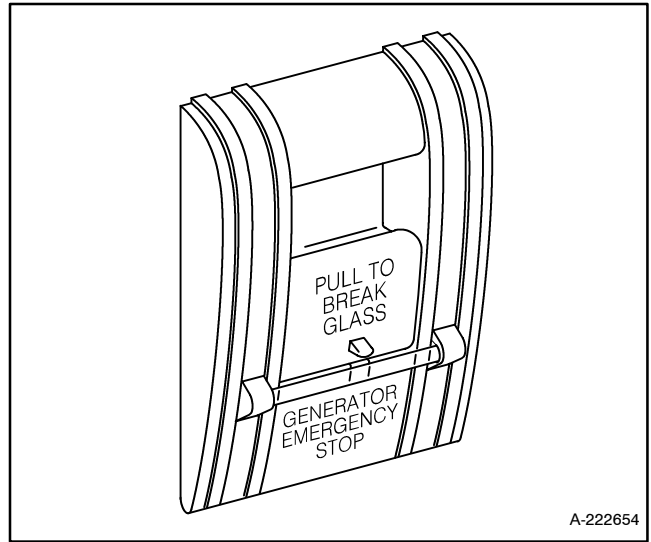

Figure 1-8 Emergency Stop Kit

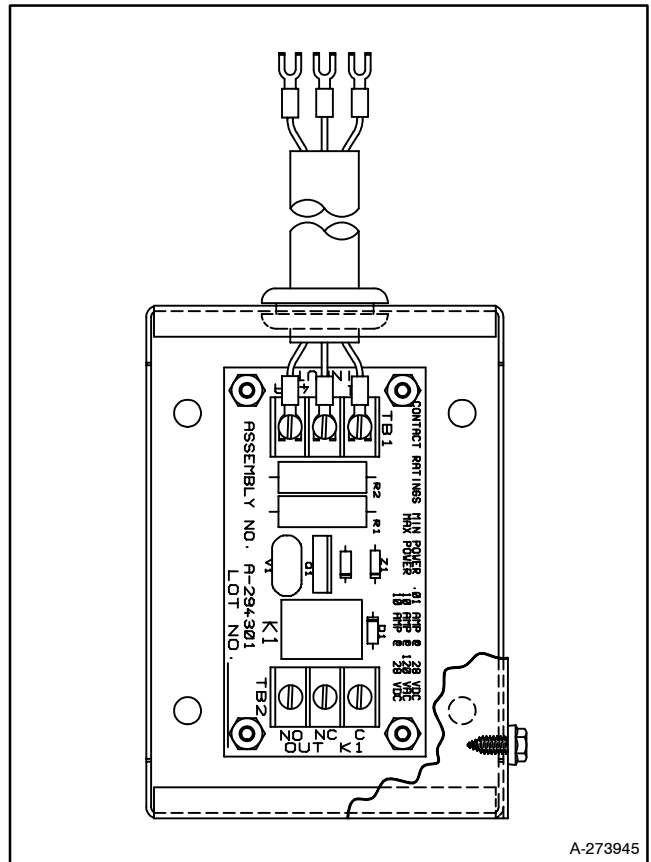

Figure 1-9 Single-Relay Dry Contact Kit

1.7.8 Ten-Relay Dry Contact Kit (Microprocessor Controller)

The ten-relay dry contact kit allows monitoring of the standby system and/or the ability to activate accessories such as derangement panels. The kit includes ten sets of relay contacts for connection of customer-provided devices to generator set functions. Connect warning devices (lamps, audible alarms) and other accessories to the controller outputs listed. Connect a total of three dry contact kits to the controller. An internal view of the contact kit is shown in Figure 1-10. Typical contact kit output connections include:

- Overspeed
- Overcrank
- Low Oil Pressure
- Auxiliary Fault
- Emergency Stop

1.7.9 Accessory Connection (Microprocessor Controller)

The Decision-Maker™ 3 controller circuit board is equipped with a terminal strip (TB1) for easy connection of generator set accessories. Do not direct connect accessories to the controller terminal strip. Connect all accessories to either a single-relay dry contact kit or to a ten-relay dry contact kit. Connect the dry contact kit(s) to the controller terminal strip. Connect alarms, battery chargers, remote switches, and other accessories to the dry contact kit relay(s) using 18 or 20 gauge stranded wire.

To connect accessories to the controller TB1 terminal strip, lower the controller circuit board panel until it is lying flat. Route dry contact relay leads through the controller port and guide loops to the circuit board terminal strip. The controller circuit board panel must be lying flat to ensure adequate slack in dry contact relay leads and/or harnesses. For specific information on accessory connections, refer to Figure 1-11, the accessory wiring diagram, and the instruction sheet accompanying each kit.

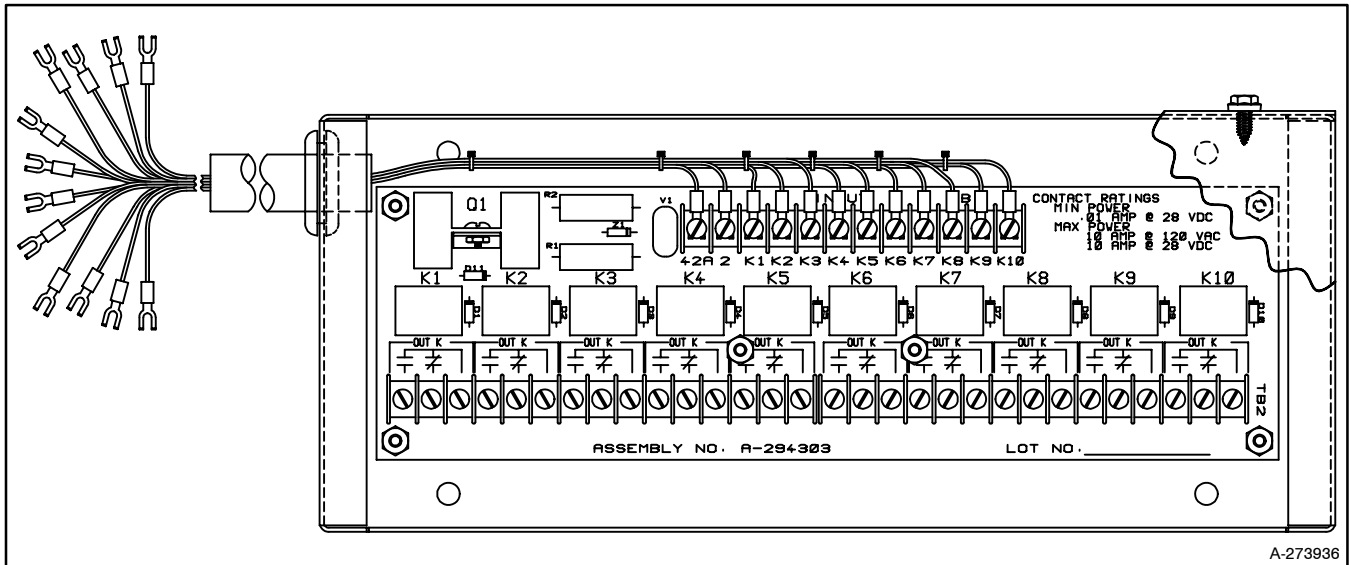

Figure 1-10 Ten-Relay Dry Contact Kit

Section 2 Scheduled Maintenance



2.1 Introduction

Schedule routine maintenance using Section 2.2, Service Schedule, and the hourmeter located on the generator controller. If the generator set will be subject to extreme operating conditions, service the unit more frequently. Instructions to perform most of the scheduled services are provided in the following pages.

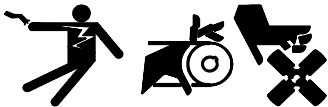
Refer to the generator set operation manual for general maintenance procedures and the engine service manual for engine maintenance procedures not provided in this manual. If the service schedule in this generator set service manual differs from that of the generator set operation manual, use the service schedule which provides the more stringent requirements.

⚠ WARNING
Accidental starting. Can cause severe injury or death.
Disconnect the battery cables before working on the generator set. Remove the negative (-) lead first when disconnecting the battery. Reconnect the negative (-) lead last when reconnecting the battery.

Disabling the generator set. Accidental starting can cause severe injury or death. Before working on the generator set or connected equipment, disable the generator set as follows: (1) Move the generator set master switch to the OFF position. (2) Disconnect the power to the battery charger. (3) Remove the battery cables, negative (-) lead first. Reconnect the negative (-) lead last when reconnecting the battery. Follow these precautions to prevent starting of the generator set by an automatic transfer switch, remote start/stop switch, or engine start command from a remote computer.

	
⚠ WARNING	
Hazardous voltage. Moving rotor. Can cause severe injury or death.	
Operate the generator set only when all guards and electrical enclosures are in place.	

⚠ WARNING
Rotating parts. Can cause severe injury or death.
Operate the generator set only when all guards, screens, and covers are in place.

Tightening the hardware. Flying projectiles can cause severe injury or death. Loose hardware can cause the hardware or pulley to release from the generator set engine and can cause personal injury. Retorque all crankshaft and rotor hardware after servicing. Do not loosen the crankshaft hardware or rotor throbolt when making adjustments or servicing the generator set. Rotate the crankshaft manually in a clockwise direction only. Turning the crankshaft bolt or rotor throbolt counterclockwise can loosen the hardware.

Servicing the generator set when it is operating. Exposed moving parts can cause severe injury or death. Keep hands, feet, hair, clothing, and test leads away from the belts and pulleys when the generator set is running. Replace guards, screens, and covers before operating the generator set.

Perform the items listed in the service schedule at the designated intervals for the life of the generator set. For example, an item to be serviced every 100 hours or 3 months must also be serviced after 200 hours or 6 months, 300 hours or 9 months, etc. The generator set will eventually accumulate enough hours to warrant a complete overhaul. The exact time at which extensive service will be necessary cannot be predicted. However, rough operation, lack of power, and excessive oil use indicate serious generator set problems. As part of a preventive maintenance program, service the engine (clean cylinder head, inspect valves, check compression, etc.) and generator set (replace bearing, inspect wiring, remove debris, etc.) at the earliest indication that a serious problem exists.

2.2 Service Schedule

System—Component	Procedure					Frequency W=Weekly M=Monthly Q=Quarterly S=Six Months Y=Yearly No.=Hours
	Visually Inspect	Check	Change	Clean	Test	
<ul style="list-style-type: none"> Follow procedures and frequencies indicated in the engine manufacturer's maintenance manual. If not indicated, follow this service schedule. Some items may not pertain to specific generator sets. X Action R Replace as necessary						
Fuel						
Flexible lines and connections	X		R			W
Fuel level switch	X				X	W
Main tank supply level		X				W
Solenoid valve operation	X				X	W
Water in system, remove		•		•		W
Filter(s)			•			Q
Gasoline supply			R			S
Fuel piping	X					Y
Lubrication						
Oil level	•	•				W
Crankcase breather	•		•			Q
Change oil			•			50 or Y
Replace filter(s)*			•			50 or Y
Cooling						
Air cleaner to room/enclosure		X				W
Block heater operation		X				W
Coolant level	•	•				W
Flexible hoses and connectors	X	X				W
Water pump(s)	•					W
Fan and alternator belts	•	•	R			M
Coolant temperature protection level					•	S
Air ducts, louvers		X		X		Y
Coolant			•			Y
Heat exchanger				X		Y
Louver motors and controls	X			X	X	Y
Radiator exterior				X		Y
Water supply to heat exchanger		X				Y
Exhaust Line						
Drain condensate trap		X				W
Leakage	X	X				W
Insulation, fire hazards	X					Q
Flexible connector(s)	X					S
Excessive back pressure					X	Y
Hangers and supports	X					Y
* Service more frequently if operated in dusty areas						
DC Electrical System						
Battery charger operation, charge rate	X					M
Battery electrolyte level		X				M
Battery specific gravity, charge state					X	M
Recharge after engine start		X				M
Remove corrosion, clean and dry battery and rack	X			X		M
Clean and tighten battery terminals	X	X				Q
Tighten DC electrical connections		X				S

Service Schedule, continued

System—Component	Procedure					Frequency
	Visually Inspect	Check	Change	Clean	Test	
<ul style="list-style-type: none"> Follow procedures and frequencies indicated in the engine manufacturer's maintenance manual. If not indicated, follow this service schedule. Some items may not pertain to specific generator sets. X Action R Replace as necessary						W=Weekly M=Monthly Q=Quarterly S=Six Months Y=Yearly No.=Hours
AC Electrical System						
Controller lamp test	X				R	W
General Inspection	X					W
Circuit breakers, fuses†	X	X	R	X	X	M
Wire abrasions where subject to motion	X	X				Q
Safety and alarm operation		X			X	S
Tighten control and power wiring connections		X				Y
Transfer switch main contacts†	X			X		Y
Voltage-sensing device/relay adjustment†		•			•	Y
Wire-cable insulation breakdown	X				X	3 Y or 500
Engine And Mounting						
General inspection	•					W
Governor operation, lubricate moving parts	•	•				M
Air cleaner service		•	•			S
Choke, carburetor adjustment		•				S
Governor oil (mechanical gov. only)		•				Y
Ignition components	•			•		Y
Injector pump and injector flow rate, pressure, spray pattern		•			•	Y
Valve clearance		•				3 Y or 500
Bolt torque		•			•	3 Y or 500
Remote Control System, etc.						
Compartment condition	X			X		W
Remote control					X	M
Run generator set					X	M
Generator						
General inspection	X					W
Rotor and stator	X			X		Y
Brushes	X	X	R			1000
Bearing condition	X	X	R			Y
Exciter	X	X		X		Y
Voltage regulator	X	X		X		Y
Measure and record resistance readings of windings with insulation tester (Megger, with SCR assembly or rectifier disconnected)					X	Y
Blow dust out of generator*	X			•		2 Y or 300
General Condition of Equipment						
Any condition of vibration, leakage, noise, temperature, or deterioration	X	X		X		W
Ensure that system is set for automatic operation	X					W
Interior of equipment room or outdoor weather housing	X			X		W

* Service more frequently if operated in dusty areas

† Do not break manufacturer's seals or internally inspect these devices

2.3 Fuel System

The generator set can be equipped with four different fuel systems: gasoline, straight gas (LP/natural gas), gas/gasoline, and LP liquid withdrawal. Each of these systems is discussed in the following paragraphs. Observe the following safety precautions when operating the generator set.

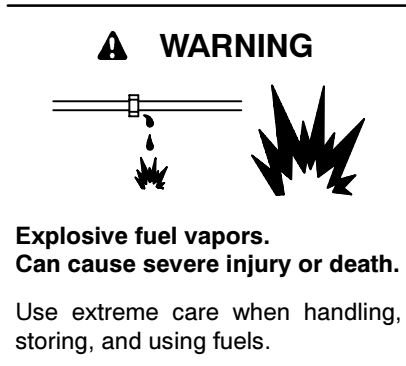

The fuel system. Explosive fuel vapors can cause severe injury or death. Vaporized fuels are highly explosive. Use extreme care when handling and storing fuels. Store fuels in a well-ventilated area away from spark-producing equipment and out of the reach of children. Never add fuel to the tank while the engine is running because spilled fuel may ignite on contact with hot parts or from sparks. Do not smoke or permit flames or sparks to occur near sources of spilled fuel or fuel vapors. Keep the fuel lines and connections tight and in good condition. Do not replace flexible fuel lines with rigid lines. Use flexible sections to avoid fuel line breakage caused by vibration. Do not operate the generator set in the presence of fuel leaks, fuel accumulation, or sparks. Repair fuel systems before resuming generator set operation.

Explosive fuel vapors can cause severe injury or death. Take additional precautions when using the following fuels:

Gasoline—Store gasoline only in approved red containers clearly marked GASOLINE.

Propane (LP)—Adequate ventilation is mandatory. Because propane is heavier than air, install propane gas detectors low in a room. Inspect the detectors per the manufacturer's instructions.

Natural Gas—Adequate ventilation is mandatory. Because natural gas rises, install natural gas detectors high in a room. Inspect the detectors per the manufacturer's instructions.

2.3.1 Gasoline Fuel Specifications

Use only clean, fresh, regular grade unleaded gasoline with a pump sticker octane rating of 87 or higher in the US. Ford engines should operate satisfactorily on gasohol blends containing no more than 10% ethanol by volume and having an antiknock index of 87 or higher. (Gasohol, a mixture of gasoline and ethanol [grain alcohol], is available in some areas.) Use fresh gasoline

to ensure it is blended for the season and to reduce the formation of gum deposits that could clog the fuel system. If storing the generator set longer than two months, refer to Section 2.12, Storage Procedures.

Note: In some cases, methanol (wood alcohol) or other alcohols may be added to gasoline. Ford engines should operate satisfactorily on blends containing up to 5% methanol by volume when cosolvents and other necessary additives are used. If not correctly formulated with appropriate cosolvents and corrosion inhibitors, such blends may cause engine performance problems or damage fuel system materials. Sufficient data is unavailable at this time to ensure the suitability of all methanol/gasoline blends. To avoid jeopardizing your engine warranty or incurring unnecessary repair costs, DO NOT USE blends that contain more than 5% methanol by volume or blends that do not contain cosolvents and corrosion inhibitors.

Note: If you are uncertain as to the presence of alcohols in the gasoline you are purchasing, check the label on the pump or ask the fuel station attendant.

Note: Discontinue use of any gasohol or alcohol/gasoline blend if fuel system problems occur. Do not use such fuels unless they are unleaded.

2.3.2 Gasoline Fuel Filter Service

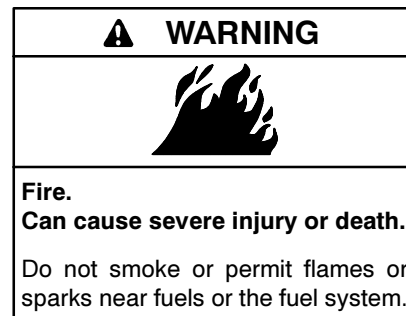

Servicing the fuel system. A flash fire can cause severe injury or death. Do not smoke or permit flames or sparks near the carburetor, fuel line, fuel filter, fuel pump, or other potential sources of spilled fuels or fuel vapors. Catch fuels in an approved container when removing the fuel line or carburetor.

The generator set utilizes an inline fuel filter connected to the outlet side of the electric fuel pump. Replace the filter every 6 months/400 hours of operation or when rough operation indicates an engine tune-up may be necessary. Location of the gasoline fuel filter is shown in Figure 2-1 and Figure 2-2.

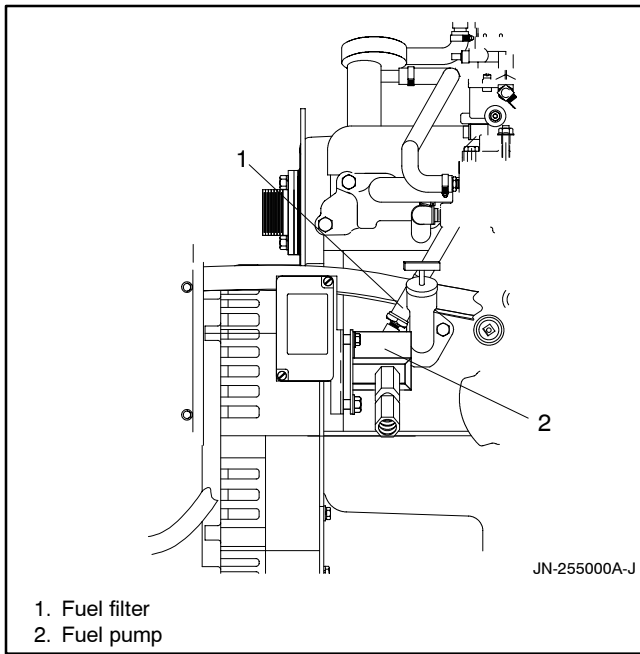

Figure 2-1 Gasoline Fuel Pump and Filter, 10/12 kW

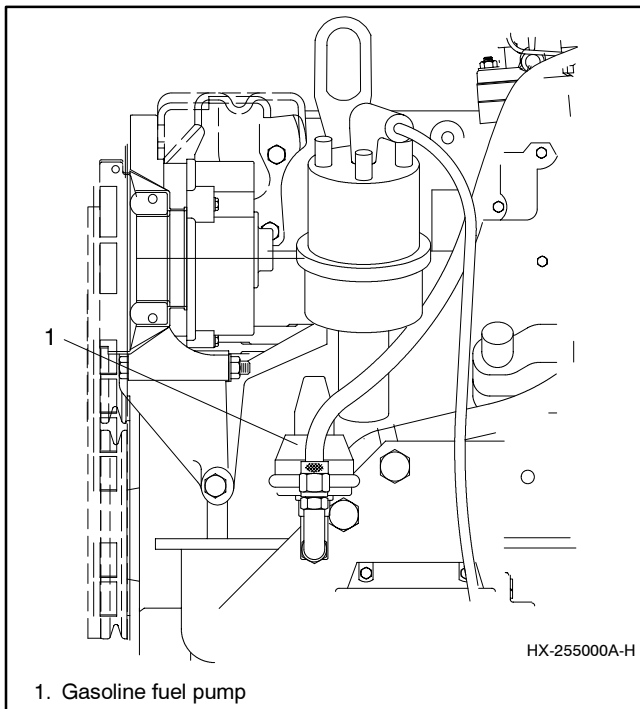

Figure 2-2 Gasoline Fuel Pump, 18 kW

2.3.3 Gasoline Carburetor Adjustments

Some generator sets may be equipped with an emission certified engine. Emission certified engines may be fitted with carburetors that have no adjustments.

Correct carburetor adjustment can only be obtained when engine compression and ignition meet specifications. Do not adjust the carburetor to compensate for other engine disorders.

Always check the condition of the air cleaner before adjusting the carburetor. A dirty air cleaner will adversely affect engine performance and carburetor adjustment.

Do not adjust carburetor to increase/decrease engine speed (Hz). Change engine speed through electronic governor adjustment. See Section 5, Component Testing and Adjustment.

The engine uses either a fixed-jet Nikki or Facet carburetor with an electric choke and fuel shutoff solenoid. The only adjustments necessary are the idle speed mixture and the automatic choke. The idle system functions only as the engine comes up through idle range to governed speed. For this reason, idle system has only a momentary effect. Under normal circumstances, carburetor adjustment is not necessary. However, if the carburetor is removed or tampered with, carburetor adjustment may be required to obtain optimum engine performance. Minor carburetor adjustment may also be necessary to compensate for differences in altitude, fuel, and temperature.

1. With ENGINE STOPPED, turn idle speed mixture screw in (clockwise) until it seats lightly. DO NOT FORCE! Turn idle speed mixture screw out 1 3/4 turns. See Figure 2-3 and Figure 2-4.

Note: Turn out throttle stop adjustment screw to prevent interference with governor/carburetor throttle rod. The throttle rod must be allowed to travel through full range of motion to avoid interfering with governor action. The throttle stop screw should have no effect on engine speed during adjustments and operation.

2. Start engine and let it run at no load for about 5 minutes. Before making adjustments, engine should be thoroughly warmed up.
3. Adjust carburetor idle speed mixture screw $\pm 3/8$ turn to achieve best stability results at no load.
4. STOP generator set.
5. If engine governed speed is incorrect, refer to Section 5, Component Testing and Adjustment, to make adjustments.

2.3.4 Gasoline Choke Adjustment

The automatic choke on the gasoline carburetor enriches the fuel mixture to improve starting at cooler temperatures. As the ambient air or engine temperature decreases, the choke automatically closes. As the engine or ambient air temperature increases, the choke plate automatically opens. If readjustment is needed, loosen the screws securing the choke bracket and shift the position of the choke assembly. See Figure 2-5. When correctly set, the choke plate should be within 10 degrees of full-closed at an ambient temperature of approximately 21°C (70°F).

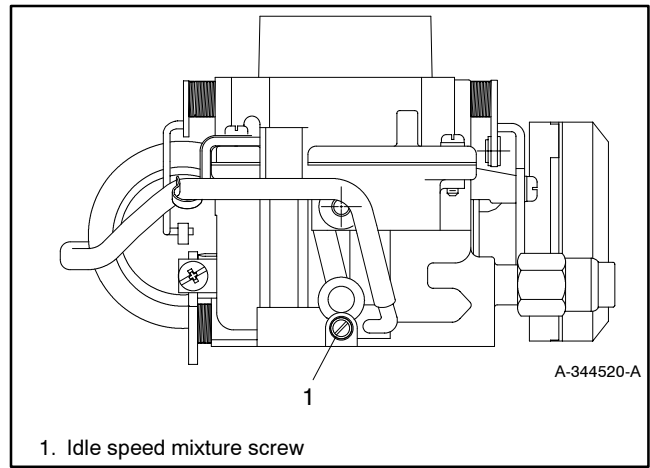

Figure 2-3 Idle Speed Mixture Adjustment, 10/12 kW

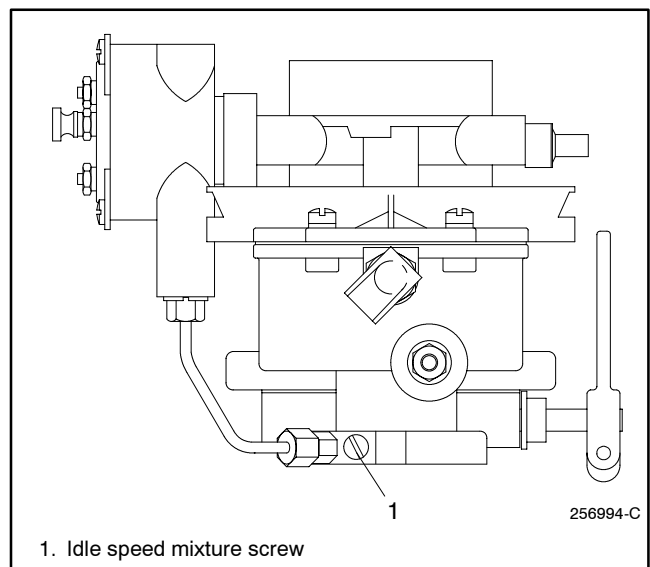

Figure 2-4 Idle Speed Mixture Adjustment, 18 kW

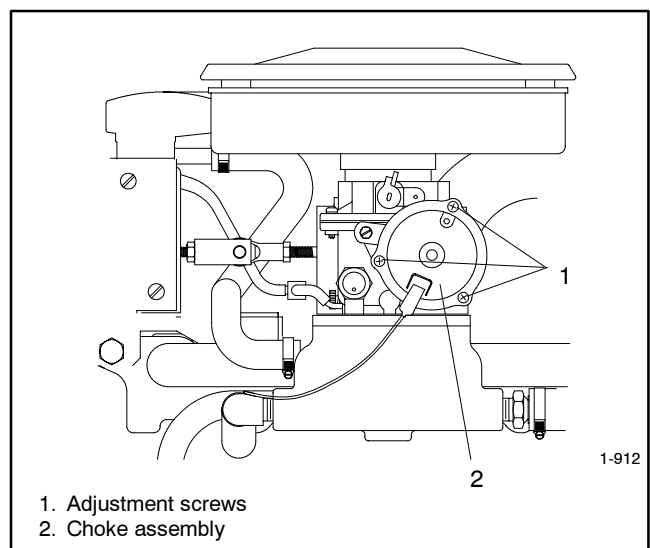



Figure 2-5 Choke Adjustment, 10/12 kW Shown

2.3.5 Gaseous Fuel Systems

The straight gas fuel system utilizes a fuel valve (with solenoid) to control fuel flow to the fuel regulator. The generator-mounted regulator reduces fuel pressure as fuel passes to the carburetor. See Figure 2-6. The carburetor controls the ratio of fuel to air under varying load and speed conditions. Because the carburetor receives fuel in a gaseous state, it does not have to provide vaporization of the fuel. When switching from natural gas to LP gas and vice versa, verify that engine speed meets specifications. The electronic governor should compensate for different types of fuel and maintain rated engine speed (1800 or 1500 rpm). If engine speed is incorrect, refer to Section 5, Component Testing and Adjustment, to make adjustments.

2.3.6 LP Gas/Natural Gas Conversion, Gaseous Fuel System

⚠ WARNING



Explosive fuel vapors. Can cause severe injury or death.

Use extreme care when handling, storing, and using fuels.

LP gas fuel leaks. Explosive fuel vapors can cause severe injury or death. Fuel leakage can cause an explosion. Check the LP vapor gas fuel system for leakage by using a soap and water solution with the fuel system test pressurized to 6-8 ounces per square inch (10-14 inches water column). Do not use a soap solution containing either ammonia or chlorine because both prevent bubble formation. A successful test depends on the ability of the solution to bubble.

The generator set can be operated on LP gas or natural gas fuel. If the set is to operate on LP gas, remove the internal spring from the gas regulator. The spring must be in place if the generator is to operate on natural gas.

To remove the internal spring from the gas regulator, remove the retaining screw from the underside of the regulator. See Figure 2-7. Remove retainer and spring, then reinstall retaining screw. Save the regulator spring and retainer for conversion back to natural gas, if necessary.

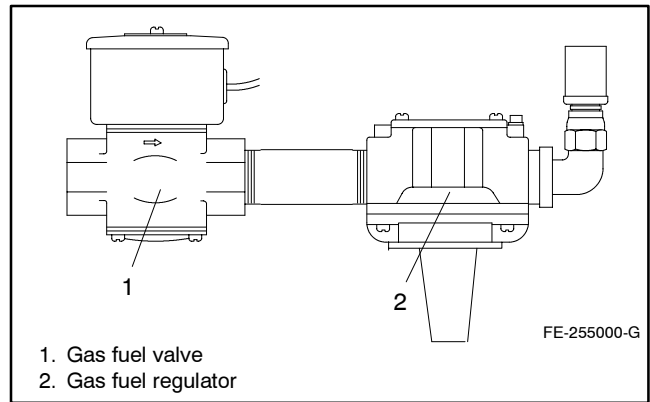

Figure 2-6 Fuel Regulator and Valve

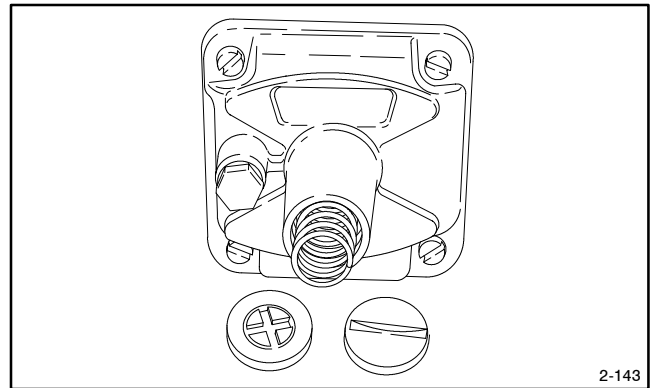

Figure 2-7 Regulator Spring and Retainer

If converting the generator back to natural gas (by replacing spring and retainer), do a manometer check on the carburetor side of the regulator. After conversion to natural gas, rotate spring retainer on regulator to obtain a constant 5 in. water column measurement on manometer with generator set at full load.

2.3.7 Carburetor Adjustment, LP/Natural Gas

Some generator sets may be equipped with an emission certified engine. Emission certified engines may be fitted with carburetors that have no adjustments. Contact an authorized service distributor/dealer about carburetor adjustments for altitude performance on emission certified engines.

Correct carburetor adjustment can only be obtained when engine compression and ignition meet specifications. Do not adjust the carburetor in an attempt to compensate for other engine disorders. If engine speed is incorrect, adjust electronic governor to obtain 1800 rpm (60 Hz) or 1500 rpm (50 Hz). If desired engine speed cannot be obtained through governor adjustment, carburetor adjustment may be necessary.

The only carburetor adjustment necessary or possible is the engine fuel mixture. Under normal circumstances, carburetor adjustment is not necessary. However, if the carburetor is removed or tampered with, carburetor adjustment may be required to obtain optimum engine performance.

To adjust the carburetor, run the generator set at approximately half-load. Rotate engine fuel mixture screw (Figure 2-8) clockwise or counterclockwise until the engine runs smoothly. Apply varying loads and adjust carburetor again, if necessary, to achieve smooth engine performance at all loads.

2.3.8 LP Liquid Withdrawal Fuel System

With the LP liquid withdrawal fuel system, LP fuel in liquid form is directed under pressure from the tank to a vaporizer. The vaporizer converts the fuel from a liquid to gaseous state. After vaporization, the LP fuel is drawn off to the carburetor. The system also includes a fuel valve which shuts off the fuel flow when the engine is stopped. The LP liquid withdrawal fuel system is available as an accessory from the distributor/dealer.

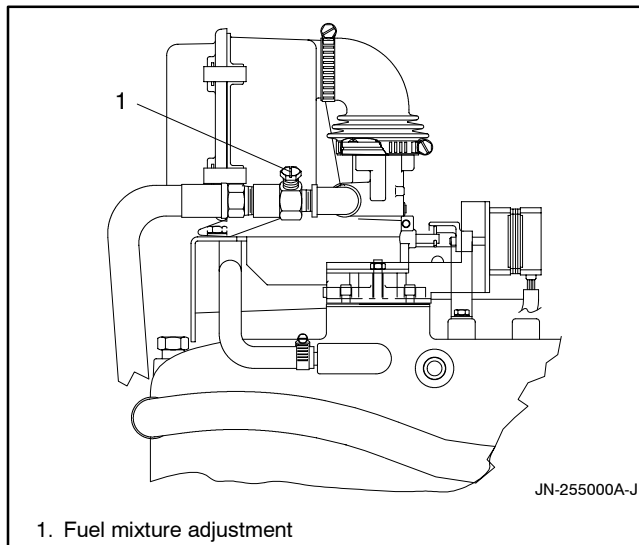

Figure 2-8 Fuel Mixture Adjustment, 10/12 kW Shown

2.3.9 Manual Changeover Fuel System Kit 18 kW Gas/Gasoline Models

The manual changeover fuel system provides manual changeover from gasoline to gas (natural gas or LP gas vapor) or gas (natural gas or LP gas vapor) to gasoline. Typically the combination system utilizes gas as the primary, preferred fuel and gasoline in emergency situations. Should the gas fuel be unavailable (LP gas vapor tank empty or a natural gas utility disruption), the gasoline fuel becomes the primary fuel. A toggle switch

on the generator set controls the fuel choice. This switch energizes either a fuel solenoid and electric fuel pump for gasoline or a fuel valve for the gas fuel.

The only scheduled maintenance is to replace the gasoline fuel filter every 6 months or 400 hours. Service more frequently if rough operation suggests the fuel filter is clogged.

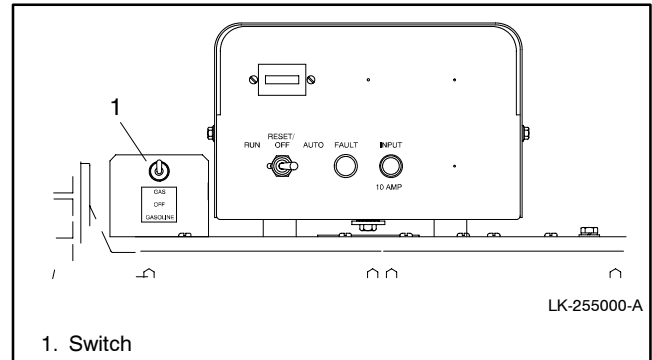

Figure 2-9 Manual Fuel Changeover Switch

2.3.10 Automatic Changeover Fuel System Kit, 18 kW Gas Models

The automatic changeover system provides automatic changeover from natural gas to LP gas vapor or from LP gas vapor to natural gas. The primary and secondary fuels each have a secondary fuel regulator and a fuel valve. Typically the primary fuel is natural gas with the backup fuel being LP gas vapor. When the generator set is started and running, the primary valve opens and the secondary fuel valve closes. The primary fuel line has a vacuum switch in series with a relay connected to the start/run circuit. When the primary fuel pressure drops below 2.5 in. water column (0.18 in. Hg), the relay energizes where the secondary fuel valve opens and the primary fuel valve closes. When the primary fuel pressure rises above 2.5 in. water column (0.18 in. Hg), the primary fuel is used again.

No scheduled maintenance applies to this fuel system.

2.4 Air Cleaner Service

The engine is equipped with a dry type air cleaner. Every 400 hours or 6 months of operation replace the air cleaner element. Replace the element more frequently if the generator set operates under dirty, dusty conditions. Operating the set with a dirty air cleaner element may cause engine damage and also increases fuel consumption. At time of service, remove all dust and foreign matter from the air cleaner housing. See Figure 2-11.

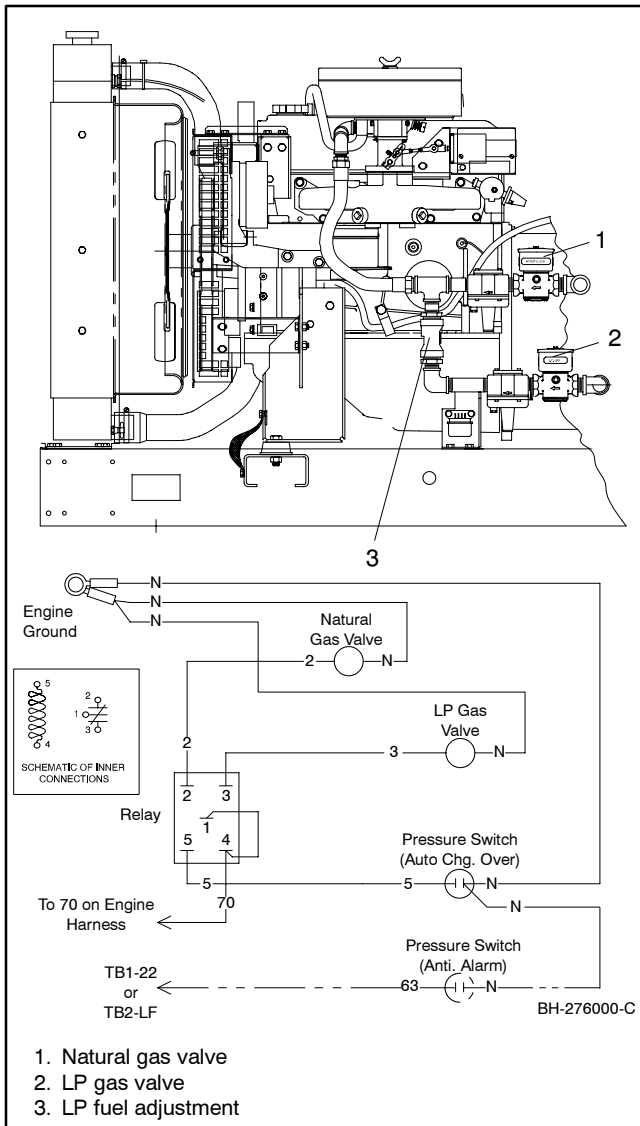

Figure 2-10 Automatic Changeover Fuel System

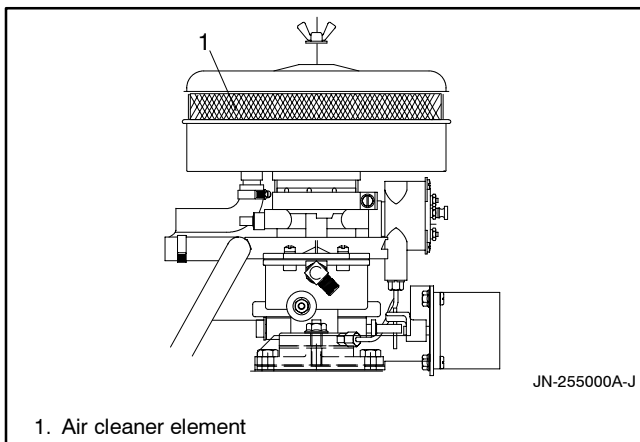

Figure 2-11 Air Cleaner Assembly, 10/12 kW Shown

2.5 Crankcase Ventilation System

2.5.1 10/12 kW

The generator set engine is equipped with a positive crankcase ventilation system. Clean air is supplied to the breather cap on the engine rocker cover by a tube from the air cleaner. A calibrated port in the cap regulates the flow of fumes into the intake manifold for combustion. See Figure 2-12. Clean the breather cap in a petroleum solvent every 3 months or 100 hours of operation and replace it yearly or every 800 hours of operation.

2.5.2 18 kW

The generator set engine is equipped with a positive crankcase ventilation (PCV) system. Clean air is supplied to the closed cap on the engine rocker cover by a tube from the air cleaner. The fumes are vented through an oil separator on the left side of the engine, then through a regulator valve and into the intake manifold. See Figure 2-13. Replace the PCV valve (regulator valve) every 400 hours of generator set operation. Clean the hoses, tubes, and fittings of this system every 800 hours of operation.

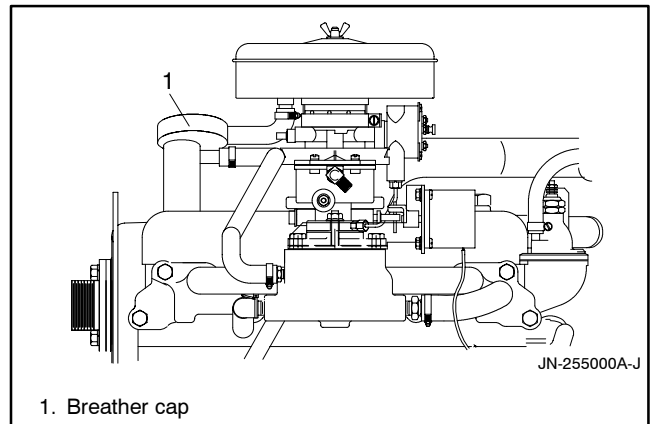

Figure 2-12 Crankcase Vent System Breather Cap, 10/12 kW

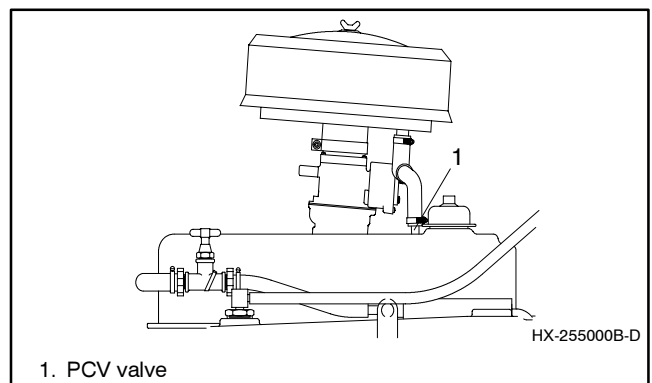

Figure 2-13 PCV Valve, 18 kW

2.6 Cooling System

2.6.1 Theory of Operation

The engine is cooled by coolant solution circulating through passages in the engine. When the engine starts, coolant in the engine block and head absorbs heat diffused by the engine during combustion. When the coolant temperature reaches approximately 90°C (195°F) on the 10/12 kW or 79°C (170°F) on the 18 kW, the cooling system thermostat opens and allows heated coolant to flow through the radiator. A fan on the water pump blows air past the radiator to lower the temperature of the coolant. The water pump recirculates the coolant through the engine to cool the engine. The cooling system is equipped with an air bleed feature to automatically draw off accumulated air from the cooling system. Do not remove the air bleed orifice from the system or engine overcooling will result.

Most 10/12 kW generator sets are equipped with a wet manifold in which the coolant solution circulates through the exhaust manifold reducing the amount of heat radiated from the exhaust into the surrounding area. The direction of coolant flow on a unit equipped with a wet manifold is illustrated in Figure 2-14. Coolant flow in an engine with a dry exhaust is based upon the same principal; however, coolant flows only through engine and then back to the radiator.

Drain the cooling system by removing the radiator cap and opening the petcock on the bottom of the radiator and the drain plug on the engine block. To refill the cooling system, close drain plug and petcock and fill radiator to the correct level with the recommended coolant mixture.

Note: For 18RY/RZ it may be necessary to bleed air from the cooling system by loosening the petcock on the service side of the engine. See Figure 2-15.

Remove radiator cap and operate the engine until the thermostat opens and the radiator upper hose becomes hot. Stop the engine and allow engine to cool, then add coolant to the radiator to 19–38 mm (3/4–1 1/2 in.) below radiator filler neck. See Figure 2-16.

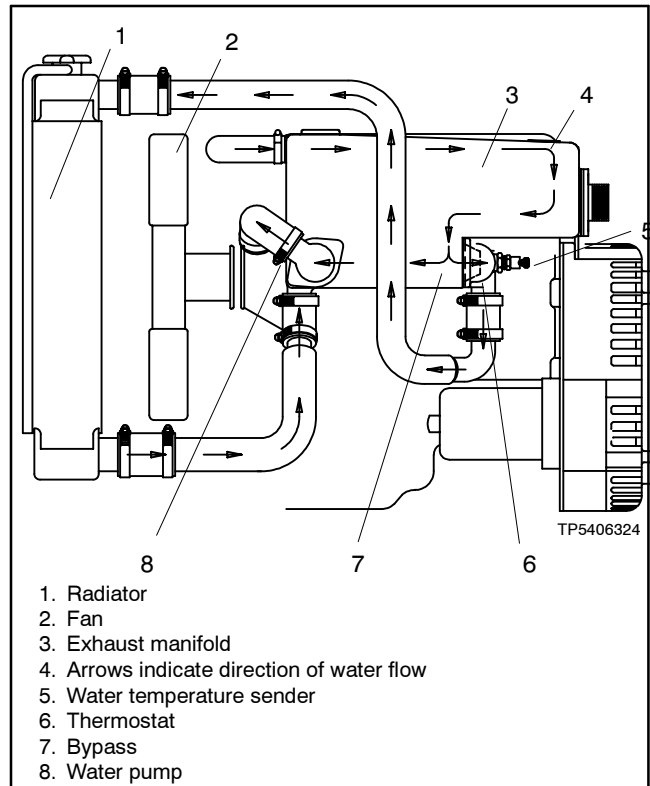

Figure 2-14 Cooling Water Circulation, Wet Manifold, 10/12 kW only

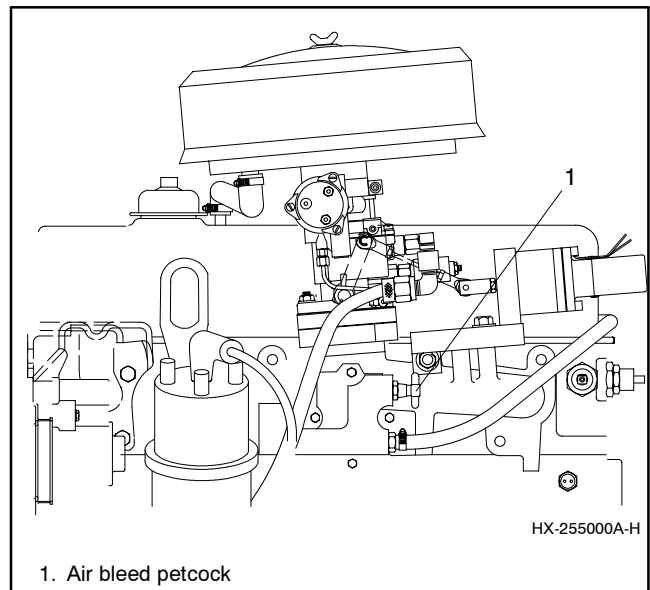

Figure 2-15 Cooling System Air Bleed Petcock, 18 kW

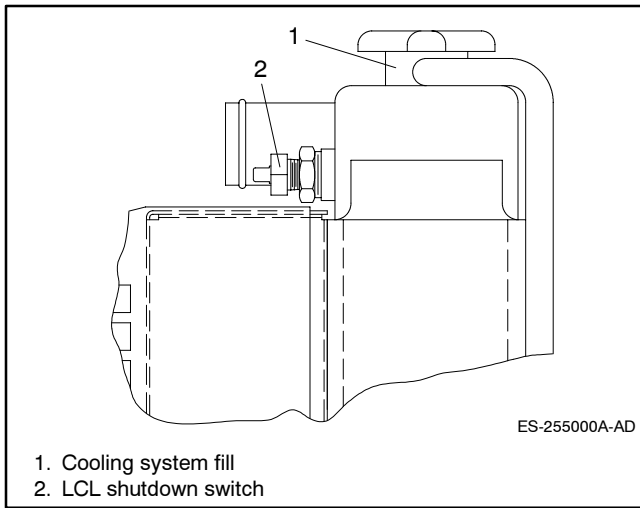



Figure 2-16 Cooling System Fill and Low Coolant Level Shutdown Switch, 10/12 kW Shown

Dispose of used engine coolant in an environmentally safe manner. Take used coolant to a suitable collection facility in your area. DO NOT POUR COOLANT ON THE GROUND, DOWN SEWERS, OR INTO STREAMS OR OTHER BODIES OF WATER.

The cooling system is equipped with an air bleed feature to automatically draw off accumulated air from the cooling system. Do not remove the air bleed orifice from the system or engine overcooling will result.

 WARNING

<p>Hot coolant and steam. Can cause severe injury or death.</p> <p>Before removing the pressure cap, stop the generator set and allow it to cool. Then loosen the pressure cap to relieve pressure.</p>

Checking the coolant level. Hot coolant can cause severe injury or death. Allow the engine to cool. Release pressure from the cooling system before removing the pressure cap. To release pressure, cover the pressure cap with a thick cloth and then slowly turn the cap counterclockwise to the first stop. Remove the cap after pressure has been completely released and the engine has cooled. Check the coolant level at the tank if the generator set has a coolant recovery tank.

Note: The block heater will fail if the heating element is not immersed in coolant. Always disconnect power to the block heater(s) before draining coolant. Fill the engine block with coolant prior to reconnecting power to block heater(s). Immerse the block heater element in engine coolant before energizing. Purge air from the system before energizing the block heater or the heater element may fail.

To prevent generator set shutdown and/or damage because of overheating, service the cooling system every 400 hours or 6 months of generator set operation. Inspect the exterior of the radiator for obstructions; remove all dirt and foreign material with a soft brush or cloth to avoid damaging radiator fins. If available, clean radiator with compressed air or a stream of water in direction opposite normal air flow. Check all hoses and connections for leaks and replace any hoses that are cracked, frayed, or spongy. When making coolant level checks, check condition of radiator cap rubber seal; replace if cracked or deteriorating. Remove dirt and other debris from radiator cap and filler neck.

Maintain coolant level at 19–38 mm (3/4–1 1/2 in.) below the radiator filler neck when the engine is cold. If the unit is equipped with a coolant recovery tank, the level in the tank should be between 1/3 full (cold) and 2/3 full (hot). Cooling system capacity is 11.8 L (12.4 qt.) for 10/12 kW and 19 L (20 qt.) for 18 kW. Use only a permanent-type coolant that meets specifications. Use a solution of 50% ethylene glycol and 50% clean, softened water to inhibit rust/corrosion. A coolant solution of 50% ethylene glycol provides freezing protection to -37°C (-34°F) and overheating protection to 129°C (265°F). A coolant solution with less than 50% ethylene glycol may not provide adequate freezing and overheating protection. A coolant solution with more than 50% ethylene glycol can cause damage to engine and components. Do not use alcohol or methanol antifreeze or mix them with the coolant.

2.6.2 Wet Exhaust Manifold

Most 10/12 kW generator sets are equipped with a wet manifold in which the coolant solution circulates through the exhaust manifold reducing the amount of heat radiated from the exhaust into the surrounding area.

The engine thermostat is located in the wet exhaust manifold. See Figure 2-17.

2.6.3 Low Coolant Level (LCL) Shutdown

If the engine coolant falls below the safe range in the radiator, the generator set automatically shuts down. The generator set will not run until coolant is added to reach the specified level and the controller is reset. Location of the low coolant level shutdown switch is shown in Figure 2-16. Refer to Section 4.1, Relay Controller, or Section 4.2.3, Fault Shutdowns, 5-Light Microprocessor Controller, for specific information on fault shutdown time delay controller resetting procedures. Procedures to test the LCL shutdown switch are included in Section 4.1.3, Safety Shutdown Switches.

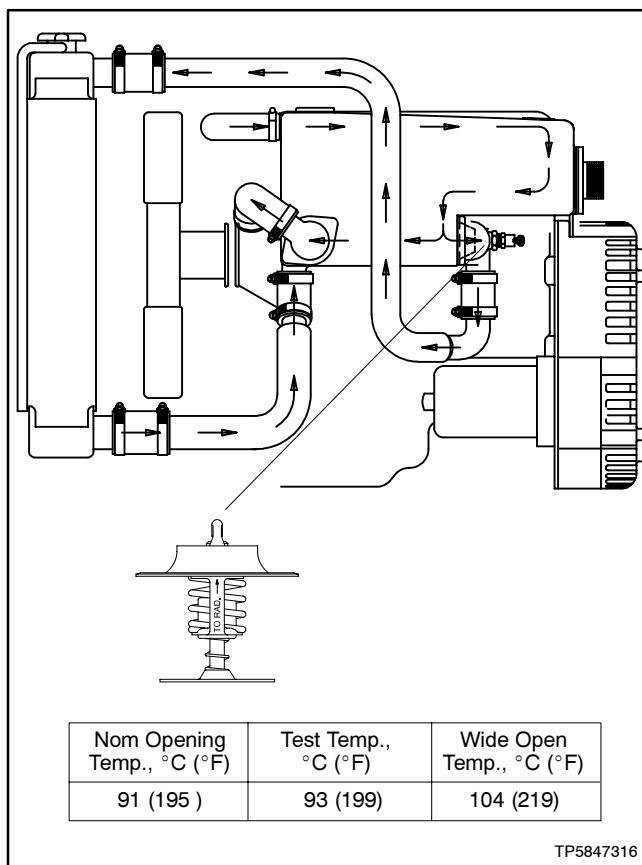

Figure 2-17 Wet Exhaust Manifold Thermostat

2.6.4 High Engine Temperature (HET) Shutdown

The engine automatically shuts down 5 seconds (5-light microprocessor controller) or 8 seconds (relay controller) after the engine temperature reaches 103°C (218°F). The engine cannot be restarted until the cause of the shutdown has been corrected or the engine has cooled. Location of the shutdown switch is shown in Figure 2-18 and Figure 2-19. Procedures to test the HET shutdown switch are included in Sections 4.1.3 and 5.

Note: The HET shutdown is not a low coolant level switch. Maintain engine coolant level for the HET shutdown switch to function.

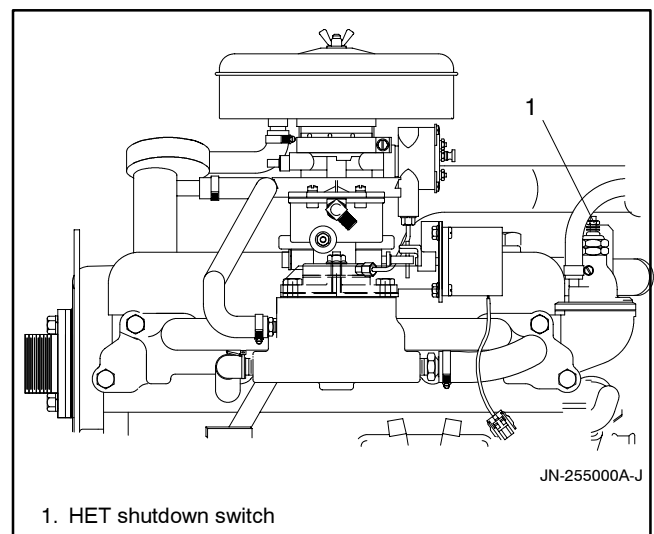

Figure 2-18 HET Shutdown, 10/12 kW

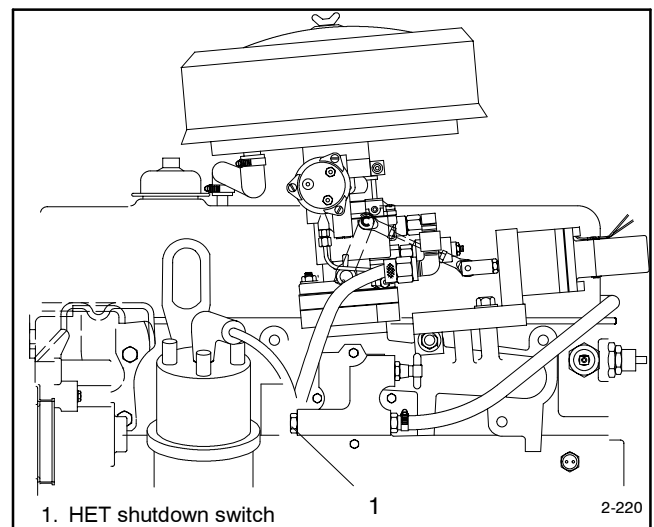

Figure 2-19 HET Shutdown, 18 kW

2.7 Drive Belts

The alternator, fan, and water pump are belt driven. The drive belts must be correctly adjusted at all times because a loose drive belt causes the belt to overheat and belt-driven components to operate incorrectly. Overtightening the belt may cause excessive wear on the alternator and water pump bearings, as well as premature belt wear. Use a belt tension gauge to check and adjust the belt tension.

Position the belt tension tool on the drive belt and check the tension according to the instructions of the tool manufacturer. See Figure 2-20. If the tension is not set to specifications, loosen the alternator and/or governor mounting and adjusting bolts. Move the component away from the engine until the correct tension is obtained. The belt tension should be 36–46 kg (79–101 lb.) on a new belt and 25–34 kg (56–75 lb.) on a used belt. (A belt in operation longer than 10 minutes is considered a used belt.) Retighten component mounting bolts.

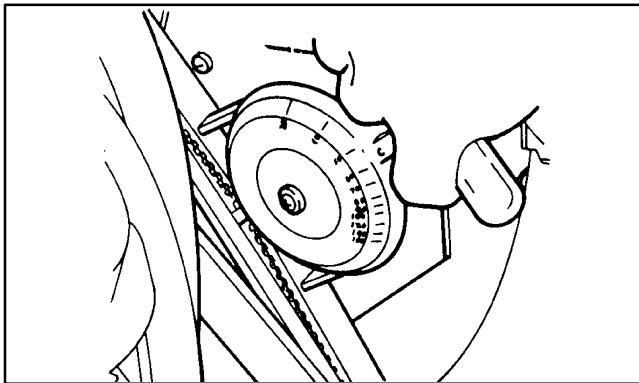

Figure 2-20 Adjusting Belt Tension

2.8 Battery Maintenance

2.8.1 General

Use a 12-volt battery with a rating of at least 235 Cold Cranking Amps (CCA) when the set operates in ambient temperatures above -1.1°C (30°F). Use a 12-volt battery with a rating of at least 400 CCA when the set operates at temperatures below -1.1°C (30°F). When using a maintenance free battery, it is not necessary to check the specific gravity or electrolyte level. Otherwise, battery maintenance should be done at the intervals specified in the service schedule. See the wiring diagrams in the wiring diagram manual for battery connections. Correctly connect and tighten battery terminals.

Note: The generator set will not start if the battery connections are made in reverse.

⚠ WARNING



Sulfuric acid in batteries.
Can cause severe injury or death.

Wear protective goggles and clothing. Battery acid may cause blindness and burn skin.

Battery electrolyte is a diluted sulfuric acid. Battery acid can cause severe injury or death. Battery acid can cause blindness and burn skin. Always wear splashproof safety goggles, rubber gloves, and boots when servicing the battery. Do not open a sealed battery or mutilate the battery case. If battery acid splashes in the eyes or on the skin, immediately flush the affected area for 15 minutes with large quantities of clean water. Seek immediate medical aid in the case of eye contact. Never add acid to a battery after placing the battery in service, as this may result in hazardous spattering of battery acid.

⚠ WARNING



Explosion.
Can cause severe injury or death.
Relays in the battery charger cause arcs or sparks.

Locate the battery in a well-ventilated area. Isolate the battery charger from explosive fumes.

Battery gases. Explosion can cause severe injury or death. Battery gases can cause an explosion. Do not smoke or permit flames or sparks to occur near a battery at any time, particularly when it is charging. Do not dispose of a battery in a fire. To prevent burns and sparks that could cause an explosion, avoid touching the battery terminals with tools or other metal objects. Remove all jewelry before servicing the equipment. Discharge static electricity from your body before touching batteries by first touching a grounded metal surface away from the battery. To avoid sparks, do not disturb the battery charger connections while the battery is charging. Always turn the battery charger off before disconnecting the battery connections. Ventilate the compartments containing batteries to prevent accumulation of explosive gases.

2.8.2 Cleaning

Keep the battery clean by wiping it with a clean, damp cloth. Keep all electrical connections dry and tight. If corrosion is present at the battery connections, disconnect cables from the battery and remove corrosion with a wire brush from the battery posts and battery cable connectors. Clean the battery and cables with a solution of baking soda and water. Be careful that cleaning solution does not enter battery cells. Flush battery and cables with clean water and wipe with a dry cloth when completed cleaning. Reconnect the battery cables, and coat terminals with petroleum jelly or other nonconductive grease.

2.8.3 Electrolyte Level Check

WARNING



**Sulfuric acid in batteries.
Can cause severe injury or death.**

Wear protective goggles and clothing. Battery acid may cause blindness and burn skin.

Battery electrolyte is a diluted sulfuric acid. Battery acid can cause severe injury or death. Battery acid can cause blindness and burn skin. Always wear splashproof safety goggles, rubber gloves, and boots when servicing the battery. Do not open a sealed battery or mutilate the battery case. If battery acid splashes in the eyes or on the skin, immediately flush the affected area for 15 minutes with large quantities of clean water. Seek immediate medical aid in the case of eye contact. Never add acid to a battery after placing the battery in service, as this may result in hazardous spattering of battery acid.

Unless the battery is maintenance free check the electrolyte level before each startup. Remove filler caps and check that electrolyte level is up to bottoms of filler holes. See Figure 2-21. Refill as necessary with distilled water or clean tap water. DO NOT add fresh electrolyte. Tighten filler caps.

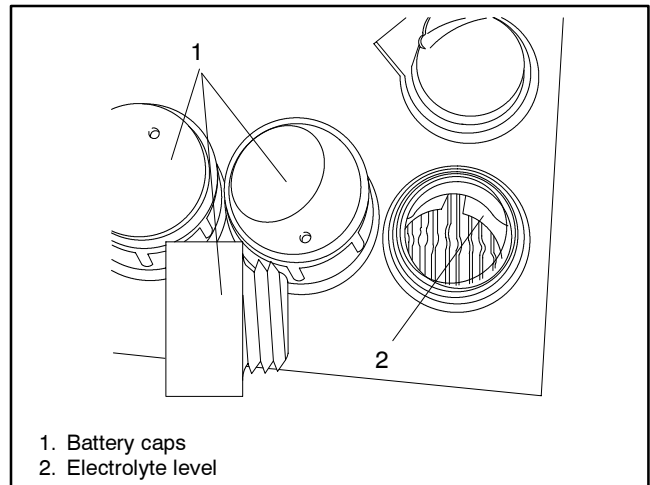

Figure 2-21 Battery Electrolyte Level

2.8.4 Specific Gravity Check

Use a battery hydrometer to check the specific gravity of the electrolyte in each battery cell. Draw battery electrolyte from a battery cell into the hydrometer. While holding the hydrometer vertically, read the number on the glass bulb at the top of the electrolyte level. The battery is fully charged if the specific gravity is 1.260 at an electrolyte temperature of 26.7°C (80°F). The difference between specific gravities of each cell should not exceed 0.01. Charge the battery if the specific gravity is below 1.215 at an electrolyte temperature of 26.7°C (80°F).

The temperature of the battery electrolyte affects the specific gravity reading and must be taken into consideration when checking battery specific gravity. If the hydrometer used does not have a temperature correction table, use the one shown in Figure 2-22.

2.8.5 Battery Charging

The generator set is equipped with a belt-driven battery charging alternator to keep the starting battery fully charged. See Figure 2-23. The battery charging alternator maintenance consists only of maintaining belt tension. To adjust alternator belt tension, see Section 2.7, Drive Belts. Be sure to observe battery polarity when connecting battery to the generator set.

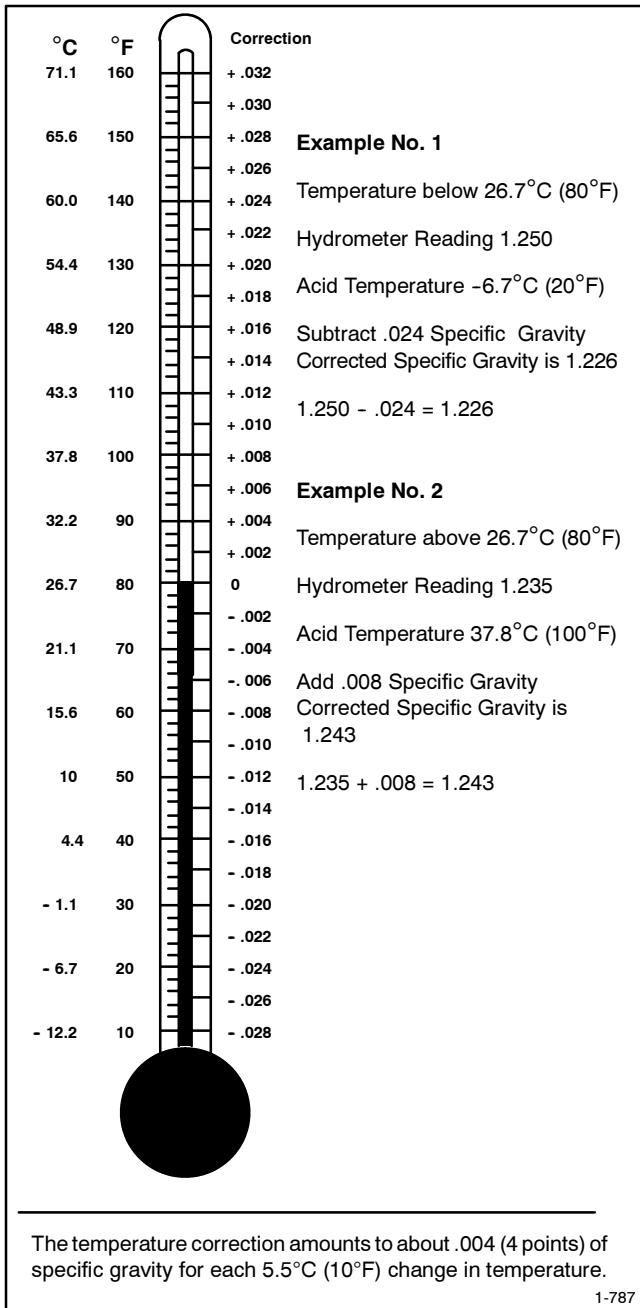

Figure 2-22 Specific Gravity Temperature Correction

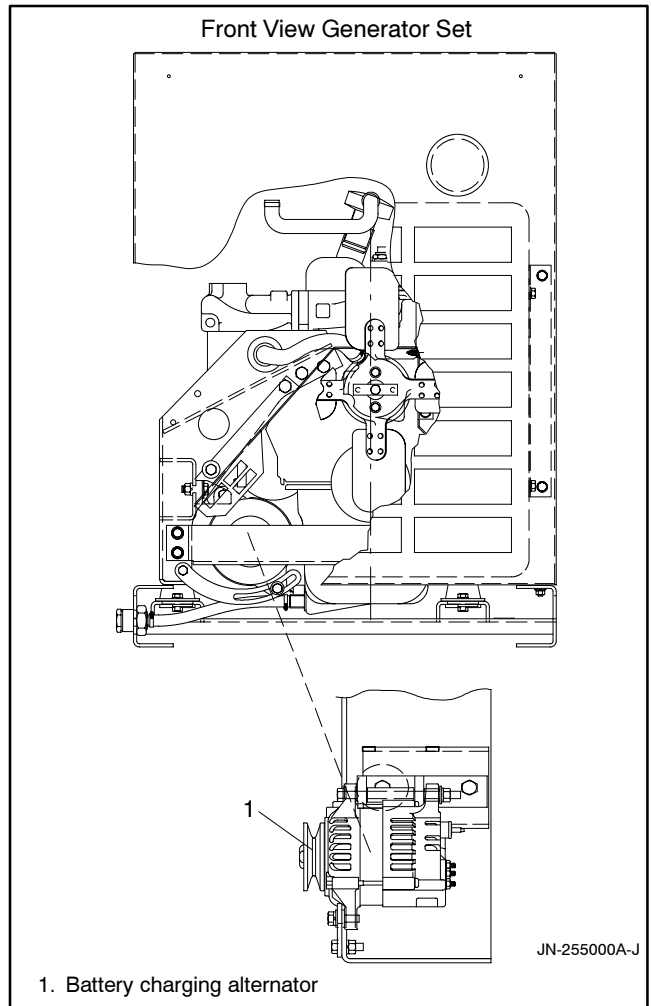



Figure 2-23 Battery Charging Alternator, 10/12 kW

2.8.6 Battery Connection

⚠ WARNING

<p>Explosion. Can cause severe injury or death. Relays in the battery charger cause arcs or sparks.</p> <p>Locate the battery in a well-ventilated area. Isolate the battery charger from explosive fumes.</p>

Battery gases. Explosion can cause severe injury or death. Battery gases can cause an explosion. Do not smoke or permit flames or sparks to occur near a battery at any time, particularly when it is charging. Do not dispose of a battery in a fire. To prevent burns and sparks that could cause an explosion, avoid touching the battery terminals with tools or other metal objects. Remove all jewelry before servicing the equipment. Discharge static electricity from your body before touching batteries by first touching a grounded metal surface away from the battery. To avoid sparks, do not disturb the battery charger connections while the battery is charging. Always turn the battery charger off before disconnecting the battery connections. Ventilate the compartments containing batteries to prevent accumulation of explosive gases.

Locate battery on or near the generator set to avoid the problem of excessive voltage drop through long cables. Refer to Figure 2-24 for battery cable lengths and sizes. Connect the generator starting battery positive cable to the starter relay positive (+) terminal shown in Figure 2-26. Connect the starting battery negative (-) cable to the negative battery terminal on the engine block. Refer to the generator set dimension drawings in the operation manual for location of the battery negative (-) connection.

2.9 Intake Manifold Bolt Torque, 10/12 kW

Torque the intake manifold bolts to specifications every 800 hours of operation or yearly. Use a torque wrench to tighten the intake manifold bolts to 16-20 Nm (12-15 ft. lb.). See Figure 2-25 for location of the intake manifold bolts on 10/12 kW generator sets.

Distance Between Generator Set and Battery, m (ft.)	At -18 C (0 F)	Cable Size (AWG) at 0 C (32 F)	Cable Size (AWG) at 24 C (75 F)
12.2 (40)	0	0	1
9.1 (30)	0	1	2
7.6 (25)	1	2	4
6.1 (20)	2	2	6
4.6 (15)	2	4	6
3.0 (10)	4	6	8
1.5 (5)	6	6	8
0.8 (2.5)	8	8	8

Figure 2-24 Battery Cable Lengths and Sizes

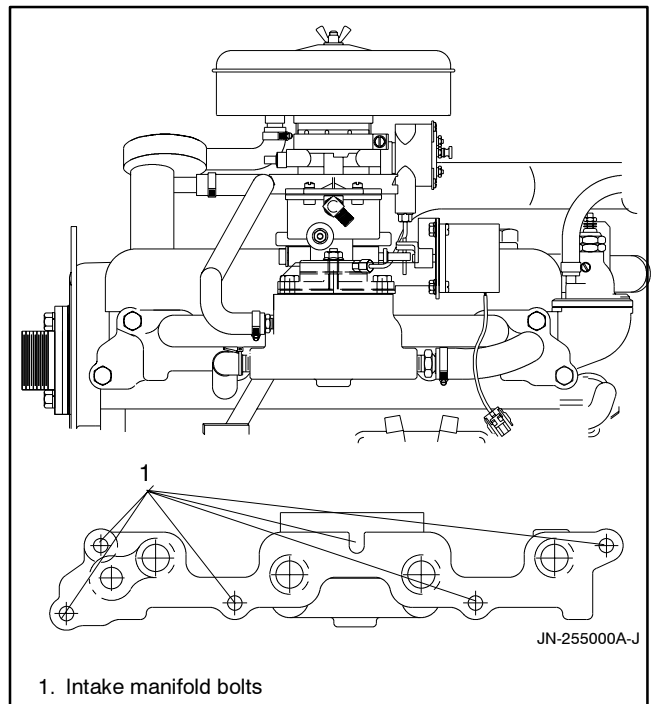

Figure 2-25 Intake Manifold Bolts, 10/12 kW

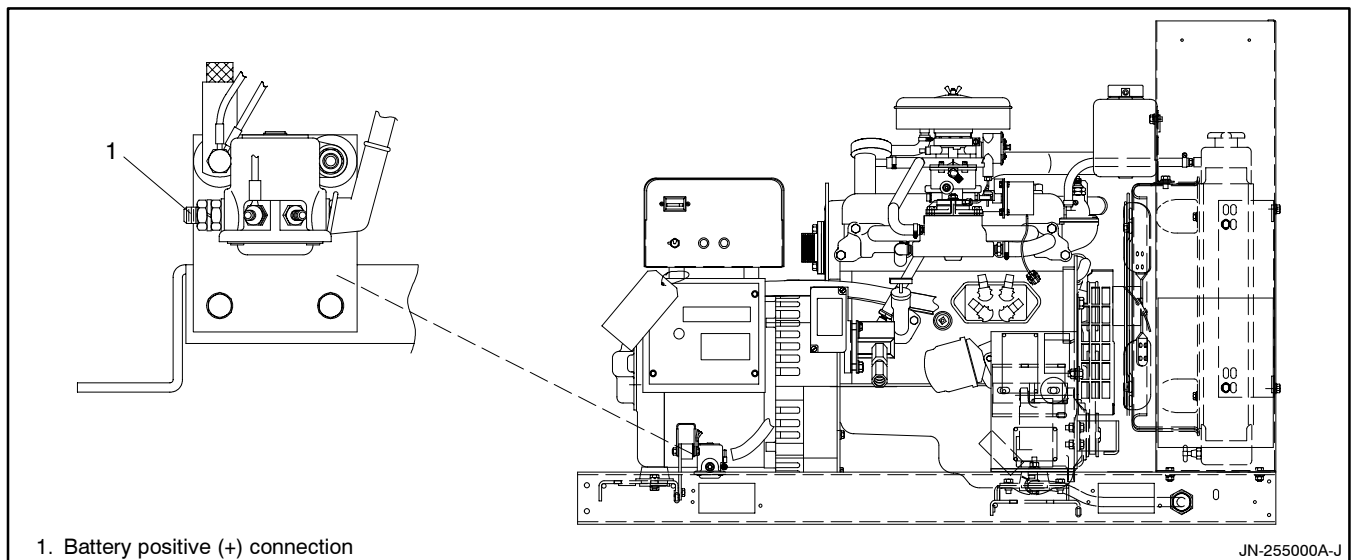

Figure 2-26 Generator Set Starting Relay (Battery Positive Connection), 10/12 kW Shown

2.10 Generator Set Service

Under normal conditions, generator set service will not be required on a regular basis. If operating under dusty and dirty conditions, use dry compressed air to blow dust out of the generator set at frequent intervals. Do this with the generator set operating and direct the stream of air in through the cooling slots at the end of the generator set.

Replace the end bracket bearing every 10,000 hours of operation in standby and prime power applications. Service more frequently if bearing inspection indicates excessive rotor end play or bearing damage from corrosion or heat buildup. The end bracket bearing is sealed and requires no additional lubrication. All generator set service must be performed by an authorized service distributor/dealer.

2.11 Wattage Requirements

Exceeding the rated capacity of the generator set trips the circuit breaker(s) located in the controller. A tripped circuit breaker could be caused by a short in the AC circuit in the electrical system or simply by having too many appliances on at the same time resulting in an overload condition. If the circuit breaker(s) trips, the set will continue running but there is no AC output to the protected circuit. Before resetting the circuit breaker(s), turn off some of the appliances and lights to bring the load down within the rated limits of the set. If after reducing the load the circuit breaker(s) trips again after being reset, the generator has a short circuit. Turn off the generator set and have a qualified electrician locate and correct the cause of the short circuit.

2.12 Storage Procedure

Perform the following steps if the generator set is out of service for three months or longer.

2.12.1 Engine Oil

1. Operate generator set for 5 minutes.
2. Stop the generator set.
3. While the engine is still warm, drain the engine lubrication oil from the crankcase.
4. Refill the engine crankcase with an oil having a viscosity appropriate for the particular climate.

5. Run the generator set for a few minutes to distribute the clean oil.
6. Stop the generator set.

2.12.2 Fuel

Fuel (Gasoline-Fueled Engines)

1. Stabilize fuel by adding fuel stabilizer according to the manufacturer's instructions or by removing fuel.
2. Drain the fuel from the fuel tank.
 - a. Drain the carburetor bowl or run generator set until empty.

Fuel (Gaseous-Fueled Engines)

1. Start the generator set.
2. With the generator set running, shut off the gas supply.
3. Run generator set until the engine stops from lack of fuel.
4. Place generator set master switch in the OFF/RESET position.

2.12.3 Coolant

1. Check engine coolant freezing protection using a coolant tester.
2. If coolant freezing protection is inadequate for the climate, add or replace coolant. See Section 2.6, Cooling System.

2.12.4 Cylinder Lubrication

1. Remove the spark plugs.
2. Pour approximately one tablespoon of engine oil into each spark plug hole.
3. Use the generator set master switch to crank the engine two or three revolutions to lubricate the cylinders. Do not start the generator set.
4. Reinstall spark plugs and torque to specifications.

2.12.5 Exterior Preparation

1. Clean exterior surface of generator set.
2. Seal all openings in the engine with non-absorbent adhesive tape.
3. Mask all electrical contact areas.
4. Spread a light film of oil over unpainted metallic surfaces to prevent rust and corrosion.

2.12.6 Battery

Perform battery storage last.

1. Place generator set master switch in the OFF/RESET position.
2. Disconnect battery(ies), negative (-) lead first.
3. Clean battery. Refer to Section 2.7, Battery Maintenance, Cleaning, for the procedure.
4. Place battery in a warm, dry location.
5. Connect battery to a float/equalize battery charger or charge once a month using a trickle battery charger. Use the battery charger manufacturer's recommendations.

Section 3 General Troubleshooting

Use the following tables as a troubleshooting quick reference. Generator set faults are listed in groups and correlated with possible causes and suggested remedies. Sources of additional information include various sections of this manual, the engine service manual, operation manual, and items listed in the reference column. Testing and corrective action often require knowledge of electrical and electronic circuits. Incorrect repair by unauthorized personnel can lead to additional costs and failures. For this reason, have repairs done only by authorized service distributor/dealer.

Note: When working with the starter relay, the following terminal lead identifiers may be used: K20, K1, or K5.

Note: When working with the field flashing relay, the following terminal lead identifiers may be used: K21, K6, or K5.

3.1 Engine Troubleshooting

Problem	Possible Cause	Corrective Action	Reference
Unit will not crank	Weak or dead battery	Recharge or replace battery.	See the operation manual
	Reversed or poor battery connections	Check connections.	
	Defective starter relay	Check continuity of circuit.	See Section 4, Controller Troubleshooting
	Defective starter	Rebuild or replace.	See Starting System in the engine service manual
	Defective controller start/stop switch (local or remote)	Test function of switch.	See Section 4, Controller Troubleshooting, and the wiring diagram manual
	Fuse blown in controller	Replace fuse; if fuse blows again, check circuit and components.	See Section 2 of the operation manual and Section 4, Controller Troubleshooting
	Open circuit in wiring, terminals pin, circuit board, etc.	Check continuity.	See Section 4, Controller Troubleshooting, and the wiring diagram manual
	Oil viscosity too heavy	Use specified oil viscosity.	See Section 2.12.1, Engine Oil
	Defective controller circuit board	Check circuit board operation.	See Section 4, Controller Troubleshooting
	Overcrank shutdown	Check engine fuel and ignition systems. Shutdown occurs after the following: Relay controller: 30 seconds of cyclic cranking 5-Light controller 45 seconds of continuous cranking 75 seconds of cyclic cranking	
Unit cranks but will not start	Out of fuel	Replenish fuel supply.	
	Air cleaner clogged	Clean or replace.	See Section 2.4, Air Cleaner Service
	Defective fuel solenoid on gasoline fuel systems	Test and/or replace solenoid.	See Section 5.5, Engine/Generator Components
	Defective ignition system spark control or ignition coil	Test and/or replace components.	See Ignition System in the engine service manual
	Faulty spark plugs or loose connections	Replace and regap spark plugs.	See Section 3, Spark Plugs
	Defective/misadjusted choke on gasoline fuel systems	Replace/readjust choke.	See Section 2.3.4, Gasoline Choke Adjustment, and Section 4, Controller Troubleshooting
	Defective fuel pump on gasoline fuel systems	Verify operation with 12 volts DC applied. Check fuel pressure of 14-24 kPa (2-3.5 psi).	See Section 5.5, Engine/Generator Components
	Clogged fuel filter on gasoline fuel systems	Replace fuel filter.	See Section 2.3, Fuel System
	Defective fuel regulator/valve on LP/natural gas systems	Check regulator/valve operation.	See Section 2.3.5, Gaseous Fuel Systems, and Section 4, Controller Troubleshooting

Engine Troubleshooting, continued

Problem	Possible Cause	Corrective Action	Reference
Unit cranks but will not start, continued	Faulty ground (-) connection	Clean and retighten.	
	Weak or dead battery	Recharge or replace.	See Section 2.8, Battery Maintenance
	Bad fuel mixture	Replace fuel; clean carburetor.	
	Blown voltage regulator fuse	Replace fuse. If fuse blows again, check generator components.	See Section 2 of the operation manual
	Insufficient fuel pressure on LP/natural gas systems	Check fuel pressure at carburetor outlet.	
	Blown controller fuse, RY 4-lead models only	Replace fuse; if fuse blows again, check circuit and components.	See Section 2 of the operation manual and Section 4, Controller Troubleshooting
	Defective antidiesel solenoid on gasoline fuel systems, 18 kW only	Test and/or replace solenoid.	See Section 5.5, Engine/Generator Components
Unit starts but shuts down after 8 seconds (relay controller) or 25-30 seconds (5-light controller)	Low oil pressure (LOP) shutdown	Correct cause of shutdown. Check oil level, oil pump, etc.	See Section 4.2.3, Fault Shutdowns, Section 5.6, Fault Shutdown Test Procedure, and the engine service manual
	High engine temperature (HET) shutdown	Check engine coolant level, belt tension, HET switch.	
	Low coolant level (LCL) shutdown	Check engine coolant level.	
Hard starting	Stale or bad fuel	Replace fuel.	
	Air cleaner clogged	Replace element.	See Section 2.4, Air Cleaner Service
	Carburetor adjustment incorrect	Readjust carburetor.	See Section 2.3.7, Carburetor Adjustment
	Faulty spark plug(s)	Replace and regap spark plug(s).	See Section 3, Spark Plugs
	Defective ignition components (spark control or ignition module)	Test/replace ignition components.	See the engine service manual
	Incorrect cooling	Inspect cooling system for low coolant level, loose belt, radiator obstructions, etc.	See Section 2.6, Cooling System
	Choke misadjusted on gasoline fuel systems	Readjust choke.	See Section 2.3.4, Gasoline Choke Adjustment
	Defective choke on gasoline fuel system	Test and/or replace.	See Section 2.3.4, Gasoline Choke Adjustment
	Worn piston rings, valves	Check compression.	See the engine service manual
	Fuel vapor lock	Check fuel line routing.	
	Insufficient fuel pressure on LP/natural gas systems	Check fuel pressure at carburetor outlet.	
Unit stops suddenly	Out of fuel	Replenish.	
	Air cleaner clogged	Replace element.	See Section 2.4, Air Cleaner Service
	Fuse blown in controller	Replace fuse.	See Section 2 of the operation manual
	Faulty spark plug(s)	Replace and regap plug(s).	See Section 3, Spark Plugs
	High engine temperature (HET) shutdown	Inspect cooling system for low coolant level, loose belt, radiator obstructions, poor ventilation, etc.	See Section 2.6, Cooling System
	Low coolant level (LCL) shutdown	Check engine coolant level. Refill as necessary.	See Section 2.6, Cooling System
	Overspeed shutdown	Check electronic governor and voltage regulator.	See Section 5.15, Electronic Governor
	Defective high engine temperature (HET) shutdown switch	Attempt startup. If unit shuts down, remove lead from HET switch and reset controller. A successful restart indicates a faulty HET shutdown switch. HET contacts close at engine temperature of approximately 103°C (218°F). Note: Verify correct engine coolant level, belt tension, and operating temperature of 77-91°C (175-195°F) before performing test and/or replacing HET shutdown switch.	See Section 2.6, Cooling System, for HET location and Section 5.14, Water Temperature and Oil Pressure Senders

Engine Troubleshooting, continued

Problem	Possible Cause	Corrective Action	Reference
Unit stops suddenly, continued	Low oil pressure (LOP) shutdown	Check engine oil level, oil pressure, and oil pump. Operating oil pressure is approximately 150 kPa (21.7 psi) for 10/12 kW and 276–414 kPa (40–60 psi) for 18 kW. LOP switch contacts close at oil pressure below 103 kPa (15 psi).	See Section 2.6, Cooling System, for location, Section 5.6, Fault Shutdown Test Procedure, and the engine service manual
	Defective low oil pressure (LOP) shutdown switch	Attempt startup. If unit shuts down, remove lead from LOP switch and reset controller. A successful restart attempt indicates a faulty LOP shutdown switch. LOP contacts close at approximately 103 kPa (15 psi). Note: Verify engine oil pressure before performing test and/or replacing LOP shutdown switch.	See Section 2.6, Cooling System, for LOP location
	Defective fuel valve/fuel regulator on LP/natural gas systems only	Check regulator/valve operation.	See Sections 2, Scheduled Maintenance, and Section 5, Component Testing and Adjustment
	Defective fuel pump on gasoline fuel systems	Check fuel pump operation. Verify operation with 12 volts DC applied. Check fuel pressure of 14–24 kPa (2–3.5 psi).	See Section 5.5, Engine/Generator Components and Engine Service Manual See Sections 2, Scheduled Maintenance, and Section 5, Component Testing and Adjustment
	Blown voltage regulator fuse	Replace fuse. If fuse blows again, test generator components.	See Section 6, Voltage Regulator
	Engine overloaded	Reduce electrical load.	See Section 2, Line Circuit Breakers, in the operation manual
	Defective antidiesel solenoid on gasoline fuel systems, 18 kW	Test and/or replace solenoid.	See Section Section 5, Component Testing and Adjustment
	Overcrank shutdown	Check rotor.	See Section 5.10, Rotor
	Vapor lock on gasoline fuel systems	Check fuel line routing.	
	Clogged fuel filter on gasoline fuel systems	Replace filter.	
	Emergency stop switch activated, if equipped	Reset	See Section 2, Resetting Procedure, in the operation manual
	Unit operates erratically	Air cleaner clogged	Replace element.
Dirty fuel filter		Replace filter.	See Section 2.3, Fuel System
Stale or bad fuel		Replace fuel.	
Faulty spark plugs		Replace and regap plugs.	See Section 3, Spark Plugs
Carburetor adjustment incorrect		Readjust carburetor.	See Section 2.3, Fuel System
Carburetor choke incorrectly adjusted on gasoline fuel systems		Readjust choke.	See Section 2.3, Fuel System
Governor adjustment incorrect		Adjust electronic governor.	See Section 5.15, Electronic Governor
Defective fuel pump on gasoline fuel systems		Verify operation with 12 volts DC applied. Check fuel pressure of 14–24 kPa (2–3.5 psi) for 10/12 kW.	See Section 5, Component Testing and Adjustment, for additional information
Carbon buildup in engine		Clean cylinder head.	See the engine service manual
Engine valves not seating correctly		Inspect valves and valve seats.	See the engine service manual
Vapor lock on gasoline fuel systems		Check fuel line routing.	
Clogged gasoline fuel filter		Replace filter.	See Section 2.3, Fuel System
Defective gasoline fuel solenoid		Test and/or replace solenoid.	See Section 5.5, Engine/Generator Components
Defective ignition system (spark control or ignition coil) or distributor		Test and/or replace components.	See Ignition System in the engine service manual

Engine Troubleshooting, continued

Problem	Possible Cause	Corrective Action	Reference
Unit lacks power	Air cleaner clogged	Replace element.	See Section 2.4, Air Cleaner Service
	Generator overloaded	Reduce load.	See Section 2, Line Circuit Breaker, in the operation manual
	Bad or stale fuel	Replace fuel.	
	Faulty spark plug(s)	Replace and regap plug(s).	See Section 3, Spark Plugs
	Carburetor adjustment incorrect	Readjust carburetor.	See Section 2.3, Fuel System
	Engine not running at rated rpm	Adjust governor.	See Section 5.15, Electronic Governor
	Governor defective or misadjusted	Test/readjust governor.	See Section 5.15, Electronic Governor
	Incorrect cooling	Inspect cooling system for low coolant level, loose belt, radiator obstructions, etc.	See Section 2.6, Cooling System
	Choke misadjusted on gasoline fuel system	Readjust choke.	See Section 2.3, Fuel System
	Fuel line restriction	Inspect fuel lines.	
	Dirty gasoline fuel filter	Replace fuel filter.	See Section 2, Scheduled Maintenance
	Defective ignition system (spark control or ignition module)	Test and/or replace.	See the engine service manual
	Carbon buildup in engine	Clean cylinder head.	See the engine service manual
	Insufficient fuel pressure on LP/natural gas system	Check fuel pressure at carburetor outlet.	
		Check fuel pipe size.	See Section 2.3, Fuel System
Unit overheats	Incorrect cooling	Inspect cooling system (low coolant level, loose belt, radiator obstructions, poor ventilation etc.).	See Section 2.6, Cooling System
	Air cleaner clogged	Replace element.	See Section 2.4, Air Cleaner Service
	Carburetor adjustment incorrect	Readjust carburetor.	See Section 2.4, Air Cleaner Service

3.2 Generator Troubleshooting

Problem	Possible Cause	Corrective Action	Reference
No AC output	Circuit breaker open or defective, if equipped	Reset breaker to ON position. Check AC voltage on generator side of circuit breaker.	See Figure 1-1 and Figure 1-2 Section 1, Service Views for location and Section 7, Generator Reconnection
	Circuit breaker tripping because of overload on generator set	Reduce load.	See Section 2, Line Circuit Breakers, in the operation manual
	No battery voltage to voltage regulator during cranking: (+) and (-) terminals on regulator	Check for DC voltage at voltage regulator terminals listed.	See Section 5.4, Voltage Regulator, and the wiring diagram manual
	Blown voltage regulator fuse	Replace fuse; if fuse blows again, check voltage regulator and/or stator auxiliary windings.	See Section 5.4, Voltage Regulator, and the wiring diagram manual
	Open wiring, terminal, or pin in buildup circuit or voltage regulator circuit	Check continuity.	See Section 5.4, Voltage Regulator, and the wiring diagram manual
	Brushes sticking in brush holder or broken brush spring	Check brush position and condition.	See Section 5.12, Brushes
	Rotor slip rings dirty or corroded	Check slip ring condition.	See Section 5.1, Theory of Operation
	Defective rotor (open, shorted, or grounded windings)	Check voltage and continuity.	See Section 5.10, Rotor
	Defective stator (open, grounded, or shorted windings)	Check voltage and continuity.	See Section 5.11, Stator
	Defective or misadjusted voltage regulator	Excite rotor separately and check for AC output. Readjust voltage regulator.	See Section 5.4, Voltage Regulator See Section 5.4, Voltage Regulator
	Defective K3 relay (field flashing) in relay controller circuit board	Test/replace relay controller circuit board.	See Section 4, Controller Troubleshooting
	Defective K20/K5 relay (field flashing) (5-light controller only)	Test/replace K5 relay.	See Section 4, Controller Troubleshooting
	Low output or excessive drop in voltage	Engine speed too low	Check engine speed using tachometer or frequency meter. Adjust governor as necessary.
Generator overloaded		Reduce load.	
Defective voltage regulator		Test/readjust voltage regulator.	See Section 5.4, Voltage Regulator
Voltage regulator incorrectly adjusted		Test/readjust voltage regulator.	See Section 5.4, Voltage Regulator
Defective rotor		Test and/or replace.	See Section 5.10, Rotor
Defective stator		Test and/or replace.	See Section 5.11, Stator
No battery charging output	Defective battery charging alternator	Test/replace alternator.	See Engine Service Manual
	Loose/defective alternator connection	Test/repair wiring and/or connections.	
	Alternator belt loose	Retighten belt.	See Section 2.7, Drive Belts
	Loose or corroded battery connections	Clean and tighten battery connections.	
	Defective battery	Check battery electrolyte level and specific gravity (batteries with filler caps only).	See Section 2.8, Battery Maintenance
High generator output voltage	Engine speed too high	Check engine speed using tachometer or frequency meter. Adjust governor as necessary.	See Section 5.15, Electronic Governor
	Defective voltage regulator	Test/readjust voltage regulator.	See Section 5.4, Voltage Regulator
	Voltage regulator incorrectly adjusted	Test/readjust voltage regulator.	See Section 5.4, Voltage Regulator
	Loose voltage regulator connections (including 33 and 44 sensing leads).	Check voltage regulator connections.	See Section 5.4, Voltage Regulator

Notes

Section 4 Controller Troubleshooting

4.1 Relay Controller

4.1.1 Description

The following text covers the controller troubleshooting procedure for 10–18 kW generator sets equipped with relay controller and related engine components. Refer to Section 2, Relay Controller Operation, in the operation manual to identify controller external components. Refer to Figure 4-1 or Figure 4-2 to identify the relay controller internal components.

4.1.2 Sequence of Operation

The following text covers the controller sequence of operation during generator start, run, stop, and fault shutdown modes. Use this as a starting point for controller fault identification. The LEDs on the controller circuit board assist in the troubleshooting process. An illuminated LED indicates the respective relay may be receiving power; the LED does not indicate whether that relay is energized. This section covers additional relay test procedures later. Refer to the wiring diagrams in the wiring diagram manual to assist in the troubleshooting procedure.

Starting

- Close the start/stop switch between N and 47 (local starting) or with switch in AUTO position close contacts 3 and 4 (remote starting).
- K2 relay energizes (LED2 lights). Normally open K2 contacts close to energize relay board (K4 relay energizes, LED4 lights) and K25 relay. Power is also supplied to hourmeter and optional oil pressure and voltmeter gauges.
- Normally open K4 contacts close to supply field flash current to rotor and energize K21 (cyclic crank) relay to provide on/off crank cycle. K21 normally open contacts close to energize K20 relay. K20 normally open contacts close to energize starter.
- K25 normally open contacts close to energize ignition module and coil, governor, deicing plate, gas valve (gaseous fueled), fuel pump, antidiesel solenoid, and choke heater (gasoline fueled).
- When engine comes up to speed, normally closed low oil pressure switch contacts open.

Note: Fault shutdowns are inhibited during startup until K3 relay (run relay) energizes.

Running

When generator set obtains specified AC output from generator 1–2 winding (1-phase) or 7–10 winding (12 lead) or engine speed reaches 1100 rpm, K3 relay energizes (LED3 lights). K3 normally closed contacts open to disconnect field flash current. K4 relay deenergizes on crank disconnect. Normally open K4 contacts open to deenergize K20 relay. K20 normally open contacts open to deenergize starter. K3 normally open contacts close to energize fault shutdown circuit after a 5-second delay.

Note: Generator set shuts down on overcrank fault if generator set fails to obtain AC output within 30 seconds.

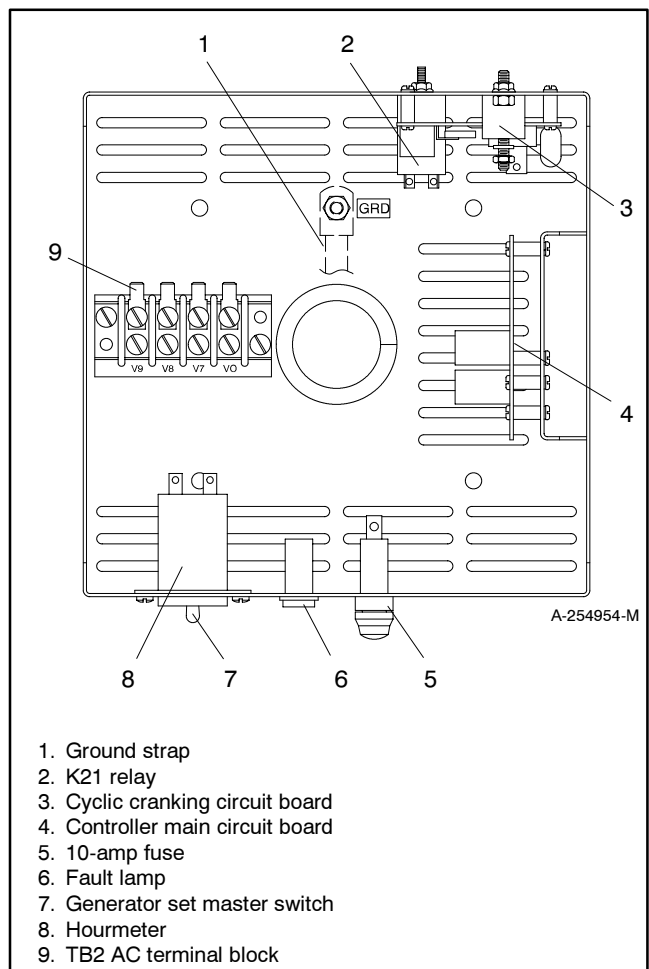

Figure 4-1 Relay Controller Internal Components

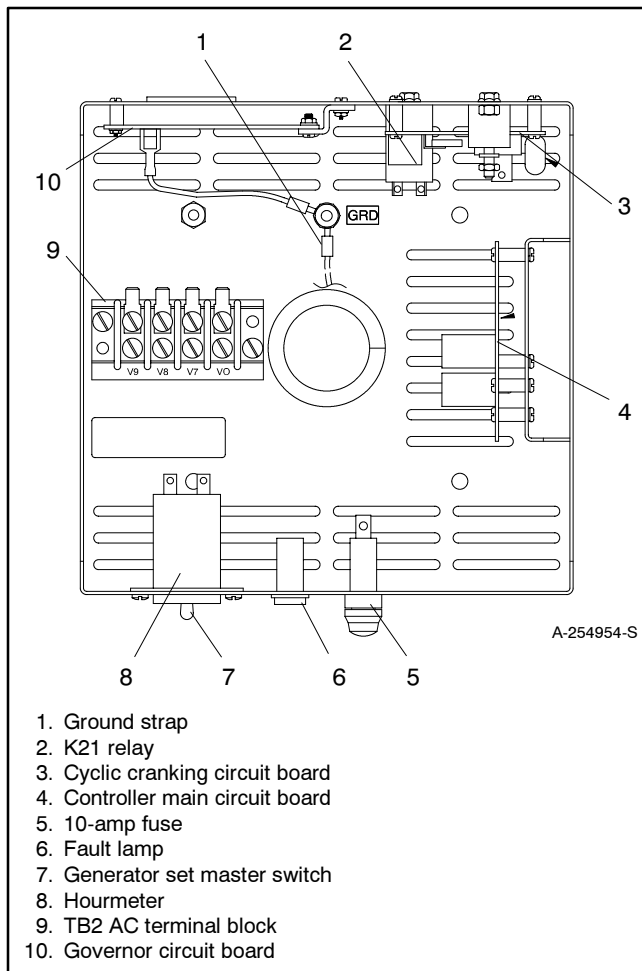

Figure 4-2 Relay Controller Internal Components (for units with the governor circuit board mounted inside the controller)

Stopping

Move the start/stop switch to OFF/RESET position. K2 relay deenergizes (LED2 goes out) and K2 normally open contacts open to deenergize relay board and K25 relay. K25 relay normally open contacts open to deenergize engine components. Generator set stops.

4.1.3 Safety Shutdown Switches

Low Oil Pressure (LOP) Shutdown

Five to eight seconds after engine lube oil pressure falls below a safe level and LOP switch closes, the K1 relay energizes (LED1 lights). K1 normally open contacts close and fault lamp lights. Normally closed K1 contacts open to deenergize K25 relay. K25 relay normally open contacts open to deenergize engine components. Generator shuts down. Fault shutdown latches. Move

generator set master switch to OFF/RESET position before restarting generator set.

High Engine Temperature (HET) Shutdown

Five to eight seconds after the engine operating temperature reaches 103°C (218°F) and HET switch contacts close, K1 relay energizes (LED1 lights). Fault lamp lights and normally closed K1 contacts open to deenergize engine components. Generator set shuts down. Fault shutdown latches. Move generator set master switch to OFF/RESET position before restarting generator set.

Low Coolant Level (LCL) Shutdown

Five to eight seconds after the engine coolant level falls below the safe range and LCL switch contacts close, K1 relay energizes (LED1 lights). Fault lamp lights and normally closed K1 contacts open to deenergize engine components. Generator set shuts down. Fault shutdown latches. Move generator set master switch to OFF/RESET position before restarting generator set.

Overspeed Shutdown

When engine speed exceeds 72 Hz (2160 rpm) on 60 Hz sets and 62 Hz (1860 rpm) on 50 Hz sets, K1 relay energizes (LED1 lights). K1 normally open contacts close and fault lamp lights. K1 normally closed contacts open to deenergize K25 relay. K25 relay normally open contacts open to deenergize engine components. Generator set shuts down. Fault shutdown latches. Move generator set master switch to OFF/RESET position before restarting generator set.

Overcrank Shutdown

If the generator does not start after three crank cycles (crank/rest, crank/rest, crank), the K1 relay energizes (LED1 lights). K1 normally open contacts close and the fault lamp lights. K1 normally closed contacts open to deenergize K25 relay. K25 relay normally open contacts open to deenergize engine components. Generator shuts down. Fault shutdown latches. Move generator set master switch to OFF/RESET position before restarting generator set.

Note: If the generator set stops from lack of fuel, the generator set will cyclic crank for 30 seconds before shutting down on overcrank. The unit attempts restart whenever 1) speed sensor detects no rotor rotation or 2) AC disconnect circuit detects no AC.

4.1.4 Relay Controller Troubleshooting

Use the following flow chart as an aid in troubleshooting the main circuit board and the entire generator set. If the prescribed remedy does not correct the problem, the circuit board may have to be replaced. The controller circuit board is equipped with LEDs (light emitting diodes) which indicate relay coil power and aid in circuit board and generator fault detection. When the K1, K2, K3, or K4 relays are receiving power, the corresponding LED lights. The LED does not indicate whether the relay coil is energized. Determine if the relay coil is energized by analyzing generator faults and by performing a continuity test on the relay coil described later in this section.

Note: When working with the starter relay, the following terminal lead identifiers may be used: K20, K1, or K5.

Note: When working with the field flashing relay, the following terminal lead identifiers may be used: K21, K6, or K5.

4.1.5 Overspeed Shutdown

The relay controller circuit board overspeed setting is adjustable using a potentiometer. See Figure 4-4 to identify the potentiometer that adjusts the overspeed setting on the relay controller circuit board.

When investigating a shutdown problem or when replacing the controller circuit board, verify that the overspeed shutdown setting is at 72 Hz (2160 rpm) for 60 Hz models and 62 Hz (1860 rpm) for 50 Hz models.

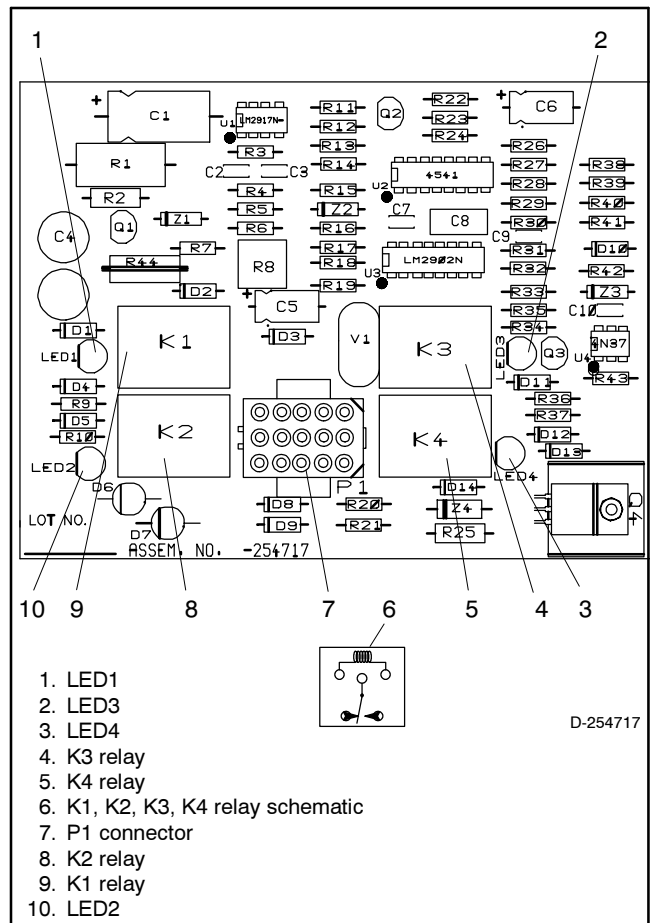

Figure 4-3 Relay Controller Circuit Board

Relay Controller Circuit Board	Potentiometer
A-254717	R8
B-254717	R8
C-254717	R8
D-254717	R12
E-254717	R12
F-254717	R13

Figure 4-4 Potentiometer Identification

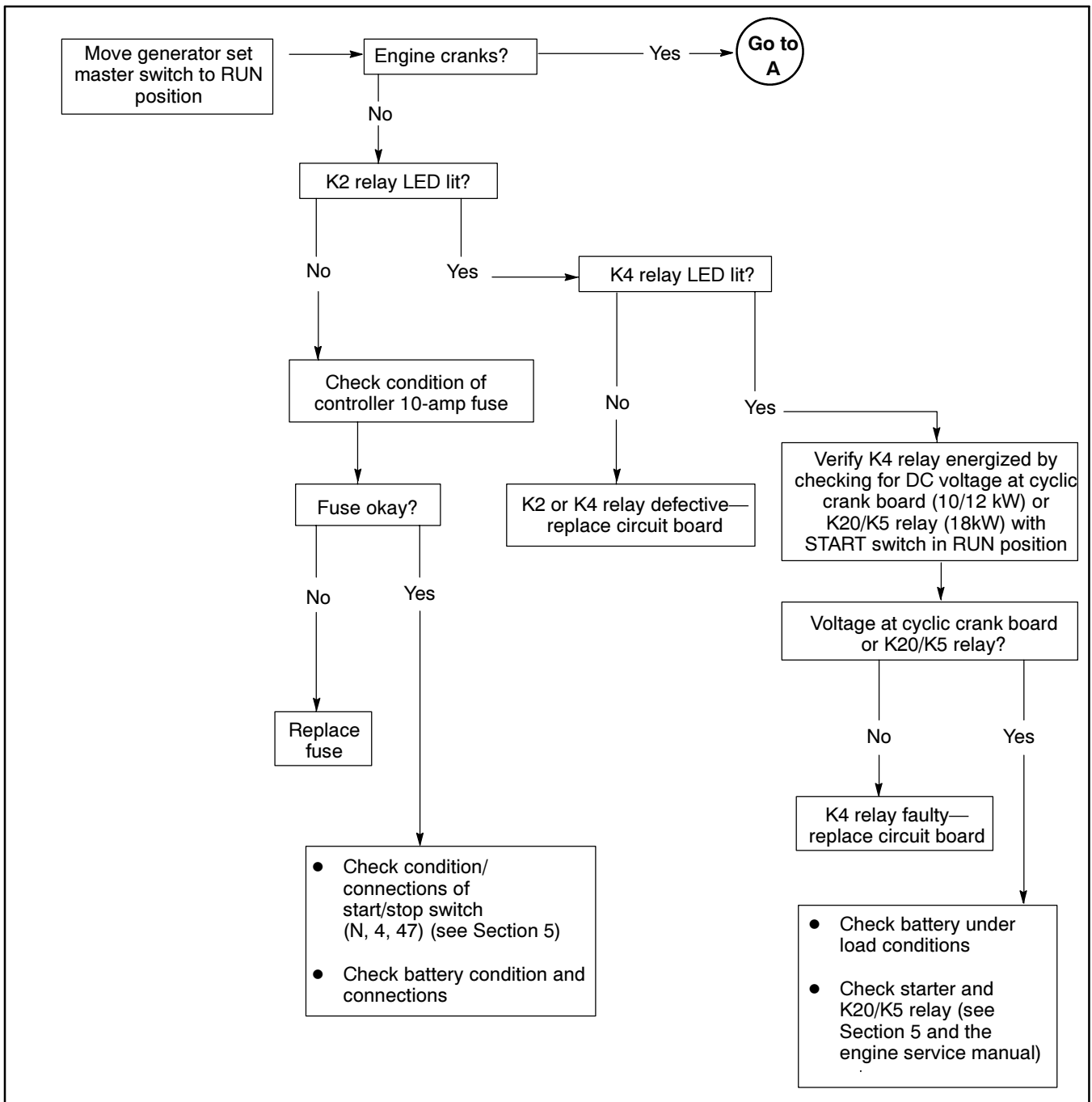

Figure 4-5 Troubleshooting Relay Controller Circuit Board (Sheet 1 of 3)

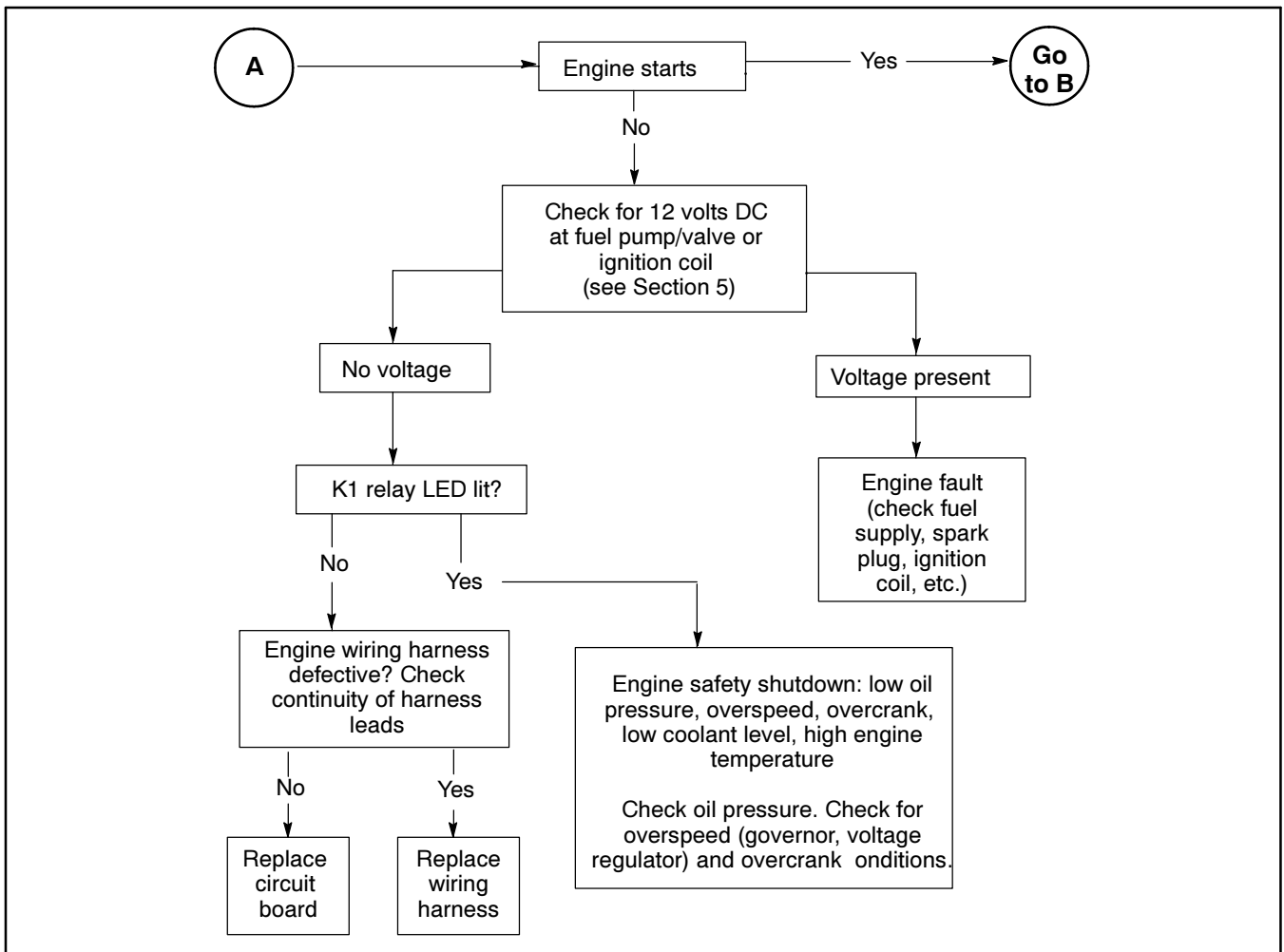

Figure 4-6 Troubleshooting Relay Controller Circuit Board (Sheet 2 of 3)

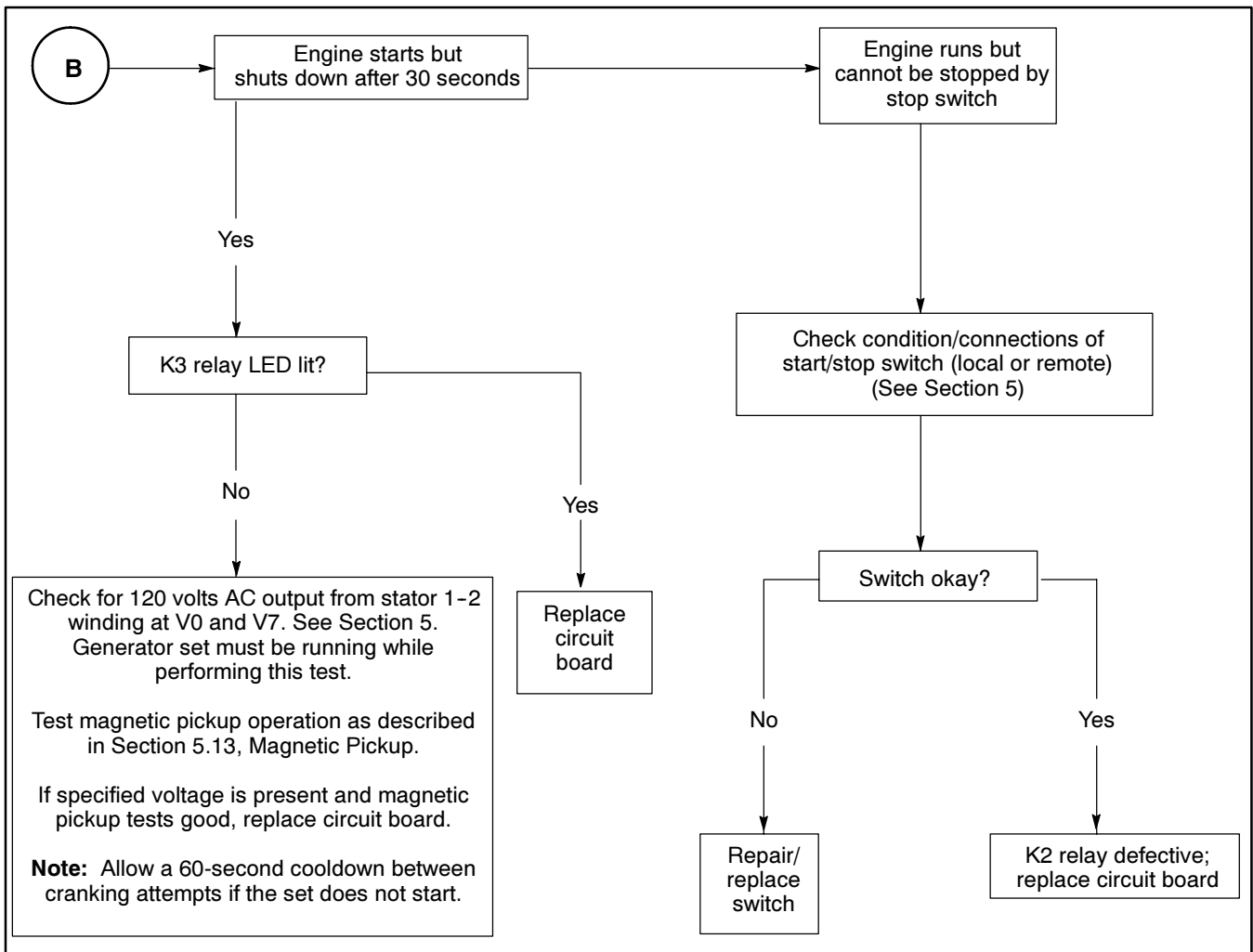

Figure 4-7 Troubleshooting Relay Controller Circuit Board (Sheet 3 of 3)

4.2 5-Light Microprocessor Controller

4.2.1 Introduction

Troubleshoot the microprocessor controller and related engine components using a combination of methods including fault detection flow charts and the FASTCHECK[®] diagnostic tester. To identify external

features, see Section 2, 5-Light Microprocessor Controller Operation, in the operation manual. Refer to Figure 4-8 to identify microprocessor controller internal components. Refer to Figure 4-9 to identify controller circuit board components. See the wiring diagram manual for a logic schematic showing input/output circuits for reference in troubleshooting the controller.

Note: Jumper must connect TB1-1 and TB1-1A terminals if no emergency stop switch is used.

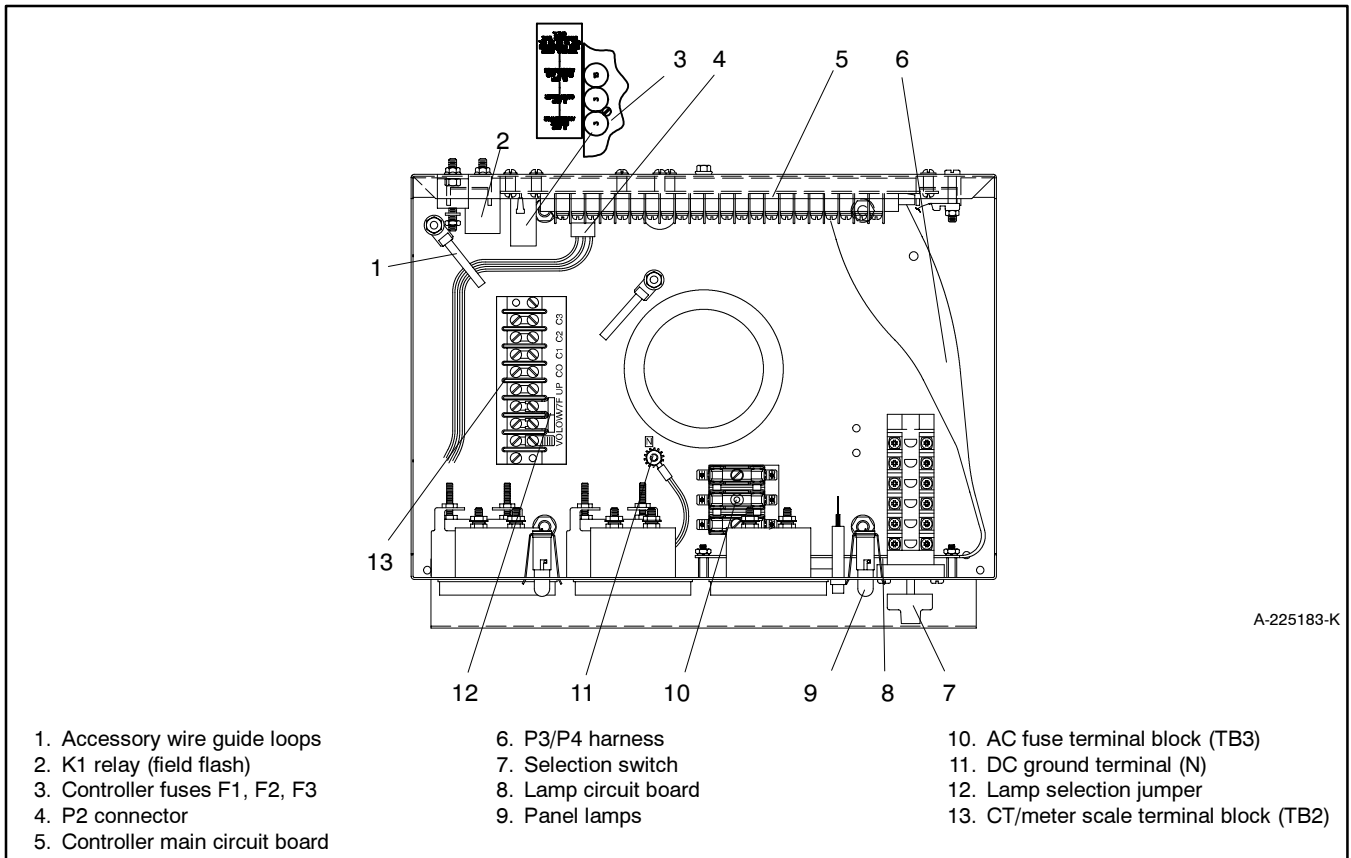

Figure 4-8 5-Light Microprocessor Controller Components

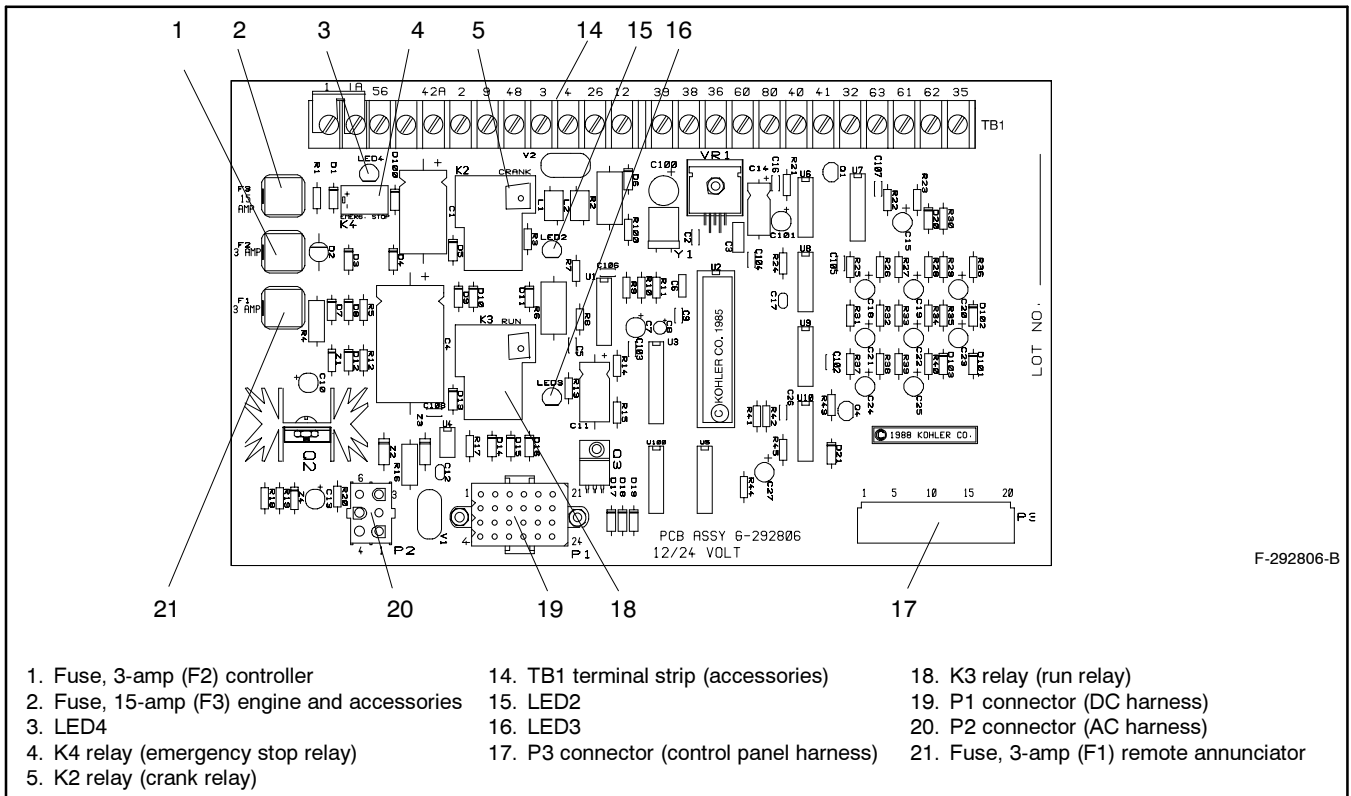

Figure 4-9 5-Light Microprocessor Controller Circuit Board Components

4.2.2 5-Light Microprocessor Controller Circuit Board Components

Terminal Strip TB1		
Terminal	Wire	Description
1	1	Ground, emergency stop relay (K4)
2	1A	Emergency stop relay (K4) coil; negative
3	56	Air damper #
4	42A	Battery voltage (fuse #1 protected)
5	2	Ground
6	9	Crank mode (open—cyclic crank; ground—continuous crank)
7	48	Emergency stop indicator
8	3	Remote start ground
9	4	Remote start (active low*)
10	26	Auxiliary indicator
11	12	Overcrank indicator
12	39	Overspeed indicator
13	38	Low oil pressure indicator
14	36	High engine temperature indicator
15	60	System ready indicator
16	80	Not-in-auto indicator
17	40	Prealarm high engine temperature indicator
18	41	Prealarm low oil pressure indicator
19	32	Common fault/prealarm line
20	63	Low fuel (active low*)
21	61	Battery charger fault (active low*)
22	62	Low battery volts (active low*)
23	35	Low water temperature

P1 Connector Pins	
Pin	Description
1	Output to K1 relay (crank relay), wire 71
2	Ground for speed sensor, wire 2
3	Output to safeguard breaker terminal, wire 70
4	Not used
5	Ground (-), wire N
6	Speed sensor shield ground, wire S2
7	Output to governor system (GS), wire 70
8	Battery positive to speed sensor, wire 24
9	Input from speed sensor, wire 16
10	Not used
11	Not used
12	Input from battery positive (P)
13	Not used
14	Input from water level switch, wire 31
15	Not used
16	Not used
17	Not used
18	Not used
19	Not used
20	Not used
21	Input from high engine temperature switch, wire 34
22	Input from low oil pressure switch, wire 13
23	Not used
24	Not used

P2 Connector Pins	
Pin	Description
1	Output to oil pressure sender, wire 70
2	Input from overvoltage board, wire 30
3	Input for AC crank disconnect & instrumentation, wire V7
4	Not used
5	Input for AC crank disconnect & instrumentation, wire V0
6	Engine ground, wire 2

P3 Connector Pins	
Pin	Description
1	Output to # low water temp/aux indicator (e. stop), wire 48
2	Output to # low water temp/aux indicator, wire 26
3	Output to overcrank indicator, wire 12
4	Output to overspeed indicator, wire 39
5	Output to low oil pressure indicator, wire 38
6	Output to high engine temperature indicator, wire 36
7	Not used
8	Voltage (+) to front panel, wire 24
9	Not used
10	Not used
11	Not used
12	Output to # low water temp/aux indicator, wire 35
13	Not used
14	Not used
15	Not used
16	Not used
17	Input from generator set master switch, RUN position, wire 47
18	Input from generator set master switch, OFF/RESET position, wire 43
19	Input from generator set master switch, AUTO position, wire 46
20	Ground (-), front panel, wire 2

P4 Connector Pins	
Pin	Description
1	Input to # low water temp/aux indicator (e. stop), wire 48
2	Input to # low water temp/aux indicator, wire 26
3	Input to overcrank indicator, wire 12†
4	Output to overspeed indicator, wire 39†
5	Input to low oil pressure indicator, wire 38†
6	Input to high engine temperature indicator, wire 36†
7	Not used
8	Voltage (+) to front panel, wire 24
9	Not used
10	Not used
11	Not used
12	Input to # low water temp/aux indicator, wire 35†
13	Not used
14	Not used
15	Not used
16	Not used
17	Output from generator set master switch, RUN position, wire 47
18	Output from generator set master switch, OFF/RESET position, wire 43
19	Output from generator set master switch, AUTO position, wire 46
20	Ground (-), front panel

* Active low circuits may be checked for proper operation by placing ground on terminals so designated.

† Common alarm triggered by high engine temp., low oil pressure, low water temp., overcrank, overspeed, low fuel, and auxiliary faults.

4.2.3 Fault Shutdowns, 5-Light Microprocessor Controller

If the generator set does not start or stops running because of a fault shutdown (fault lamp lit), refer to the following chart to identify fault conditions. Consult the engine service manual for detailed information on correcting engine-related faults. To reset the generator set after a fault shutdown, see Section 2, 5-Light Microprocessor Controller Operation—Resetting Fault Shutdowns, in the operation manual.

Indicator	Fault Condition
High Engine Temperature lamp lights	Engine coolant temperature above 103°C (218°F).
	Cooling system malfunction.
Low oil pressure lamp lights	Engine oil pressure dropped to 49 kPa (7.1 psi).
Overspeed lamp lights	Governed frequency in excess of 70 Hz (50 and 60 Hz models).
Overcrank lamp lights	More than 45 seconds of continuous cranking.
	More than 75 seconds of cyclic cranking.
	Locked rotor—engine not cranking.
Overcrank lamp flashes	Magnetic pickup signal absent longer than one second.
Low Water Temp./Auxiliary lamp lights	Engine coolant below safe range in radiator
	Overvoltage condition, if overvoltage protection equipped, output voltage 15% above nominal voltage for one second or longer.
	Activated by fault-sensing devices connected to auxiliary immediate shutdown pin (P1-17).
Emergency stop, if equipped	Emergency stop switch activated.
	Emergency stop switch disconnected from controller terminals TB-1 or 1A.

Figure 4-10 Microprocessor Controller Fault Shutdowns

4.2.4 Relay Descriptions

The descriptions given below describe the relays used on sets with 5-light microprocessor controllers. Use this information to troubleshoot the generator and in conjunction with the troubleshooting flow charts on the following pages.

K1 Relay (Starter Solenoid)

Relay energizes starter. K1 relay is located on the skid. See Figure 4-11.

K2 Relay (Crank Relay)

Relay energizes K20/K5. LED2 lights when energized during crank mode. K2 relay is located on the controller circuit board.

K3 Relay (Run Relay)

Relay energizes fuel pump, fuel solenoid, and meters/gauges.

Relay energizes engine safety shutdowns after time delay. LED3 lights when energized during crank and run modes. K3 relay is located on the controller circuit board.

K4 Relay (Emergency Stop Relay)

The K4 relay energizes continuously except during emergency stop conditions. LED4 is lit at all times except during emergency stop. K4 relay is located on the controller circuit board. If local or remote emergency stop kit is connected, remove jumper from circuit board TB1-1 and 1A. If no emergency stop kit is connected, use a jumper to connect terminals TB1-1 and 1A.

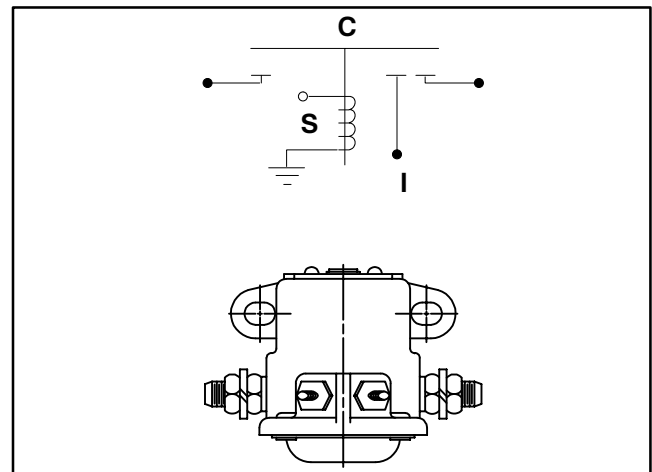

Figure 4-11 K1 Starter Solenoid

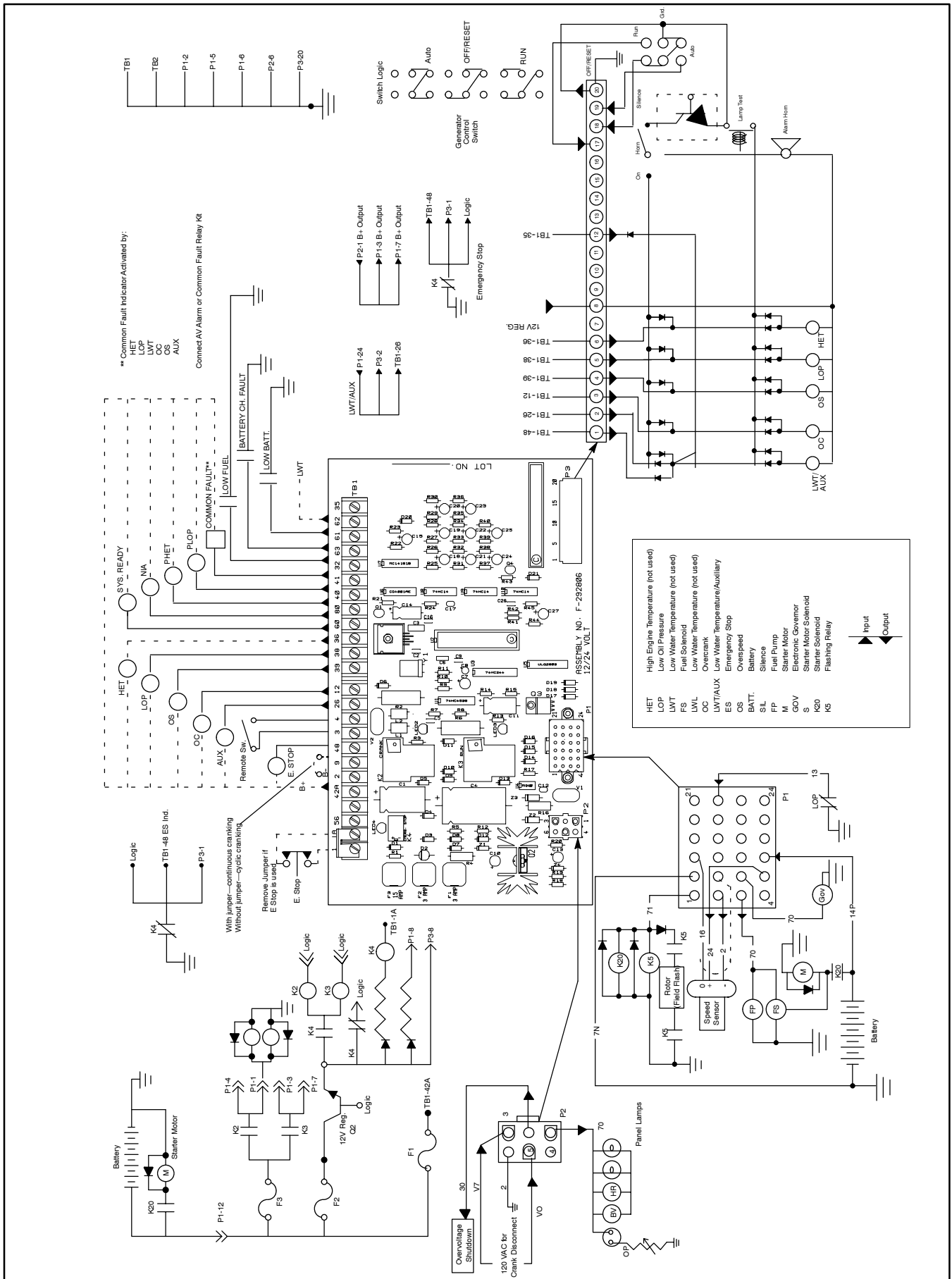

Figure 4-12 5-Light Microprocessor Controller Connections

K20/K5 Relay (Field Flashing Relay)

Provides field flashing voltage to main field (rotor) during startup. The K20/K5 relay is located in the controller and energizes only during cranking. See Figure 4-13.

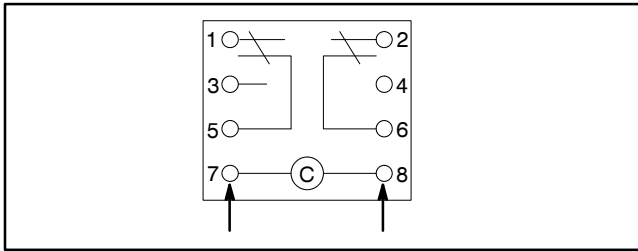
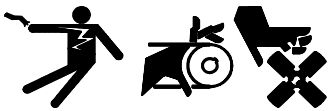

Figure 4-13 K20/K5 Flashing Relay

4.2.5 Microprocessor Controller Troubleshooting

Use the following charts as a troubleshooting quick reference for generator set problems. Consult the first chart for aid in locating the cause of blown fuses. The successive charts list generator faults in groups and correlate them with possible causes and corrective actions. Troubleshooting using the FASTCHECK[®] follows. Before beginning any troubleshooting procedure, read all safety precautions at the beginning of this manual and those included in the text. Do not neglect these safety precautions.

⚠ WARNING



**Accidental starting.
Can cause severe injury or death.**

Disconnect the battery cables before working on the generator set. Remove the negative (-) lead first when disconnecting the battery. Reconnect the negative (-) lead last when reconnecting the battery.

Disabling the generator set. Accidental starting can cause severe injury or death. Before working on the generator set or connected equipment, disable the generator set as follows: (1) Move the generator set master switch to the OFF position. (2) Disconnect the power to the battery charger. (3) Remove the battery cables, negative (-) lead first. Reconnect the negative (-) lead last when reconnecting the battery. Follow these precautions to prevent starting of the generator set by an automatic transfer switch, remote start/stop switch, or engine start command from a remote computer.

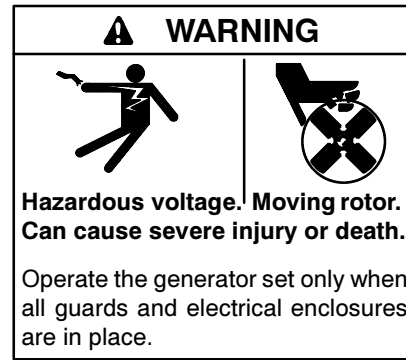

Grounding electrical equipment. Hazardous voltage can cause severe injury or death. Electrocutation is possible whenever electricity is present. Open the main circuit breakers of all power sources before servicing the equipment. Configure the installation to electrically ground the generator set, transfer switch, and related equipment and electrical circuits to comply with applicable codes and standards. Never contact electrical leads or appliances when standing in water or on wet ground because these conditions increase the risk of electrocution.

Disconnecting the electrical load. Hazardous voltage can cause severe injury or death. Disconnect the generator set from the load by opening the line circuit breaker or by disconnecting the generator set output leads from the transfer switch and heavily taping the ends of the leads. High voltage transferred to the load during testing may cause personal injury and equipment damage. Do not use the safeguard circuit breaker in place of the line circuit breaker. The safeguard circuit breaker does not disconnect the generator set from the load.

Note: If starting unit by remote switch, verify operation of remote switch before troubleshooting controller. Test remote switch operation by placing generator set master switch in the AUTO position and running a jumper between terminals 3 and 4 on controller circuit board. If the generator does not start, proceed with the controller troubleshooting procedure outlined in the following pages.

The chart in Figure 4-14 lists the possible causes of blown controller fuses F1, F2, and F3. If a fuse blows, replace it and resume operation. If the fuse blows again, use the chart to identify the faulty component(s).

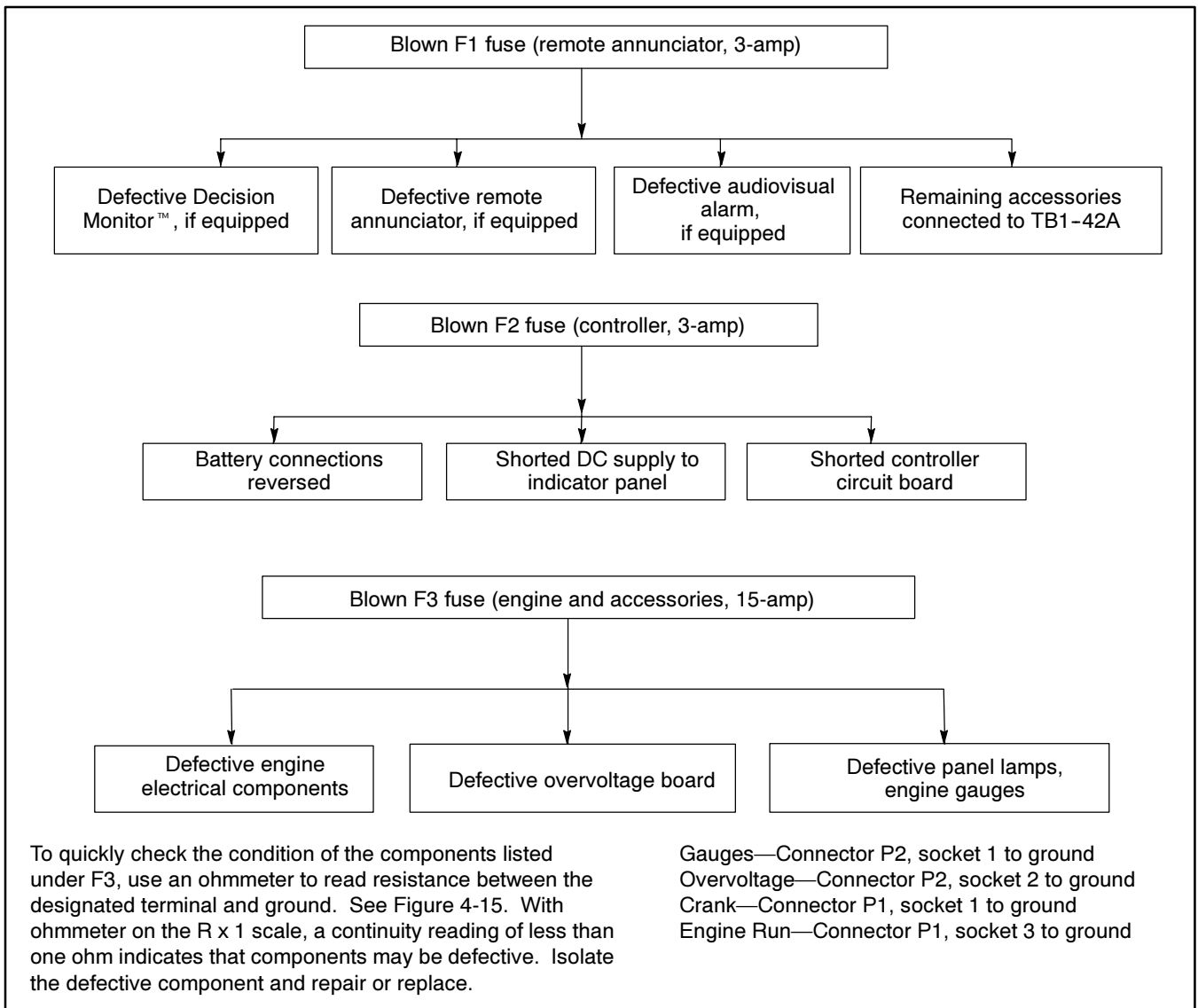

Figure 4-14 Troubleshooting Microprocessor Fuses

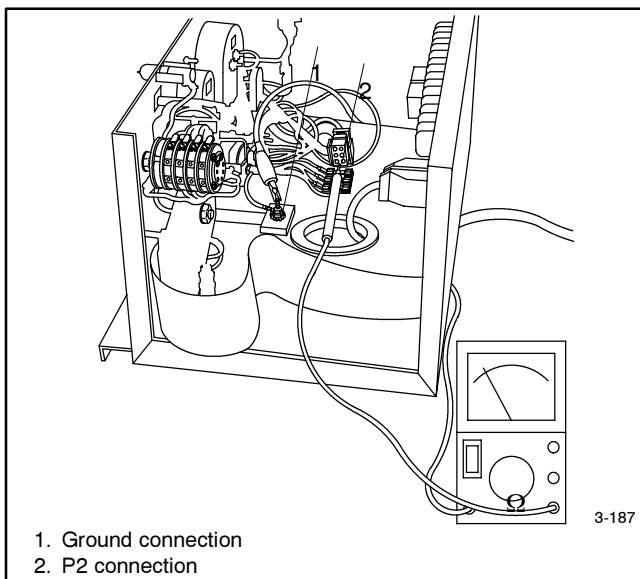

Figure 4-15 Controller P1/P2 Components

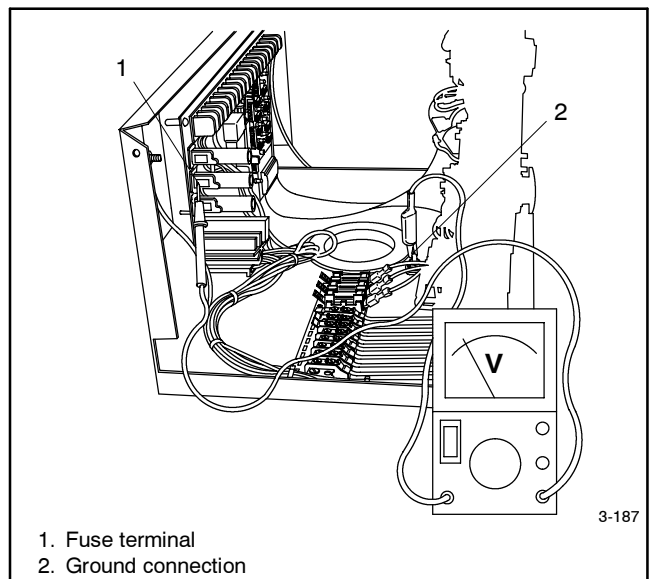

Figure 4-16 Controller, Location of Fuses

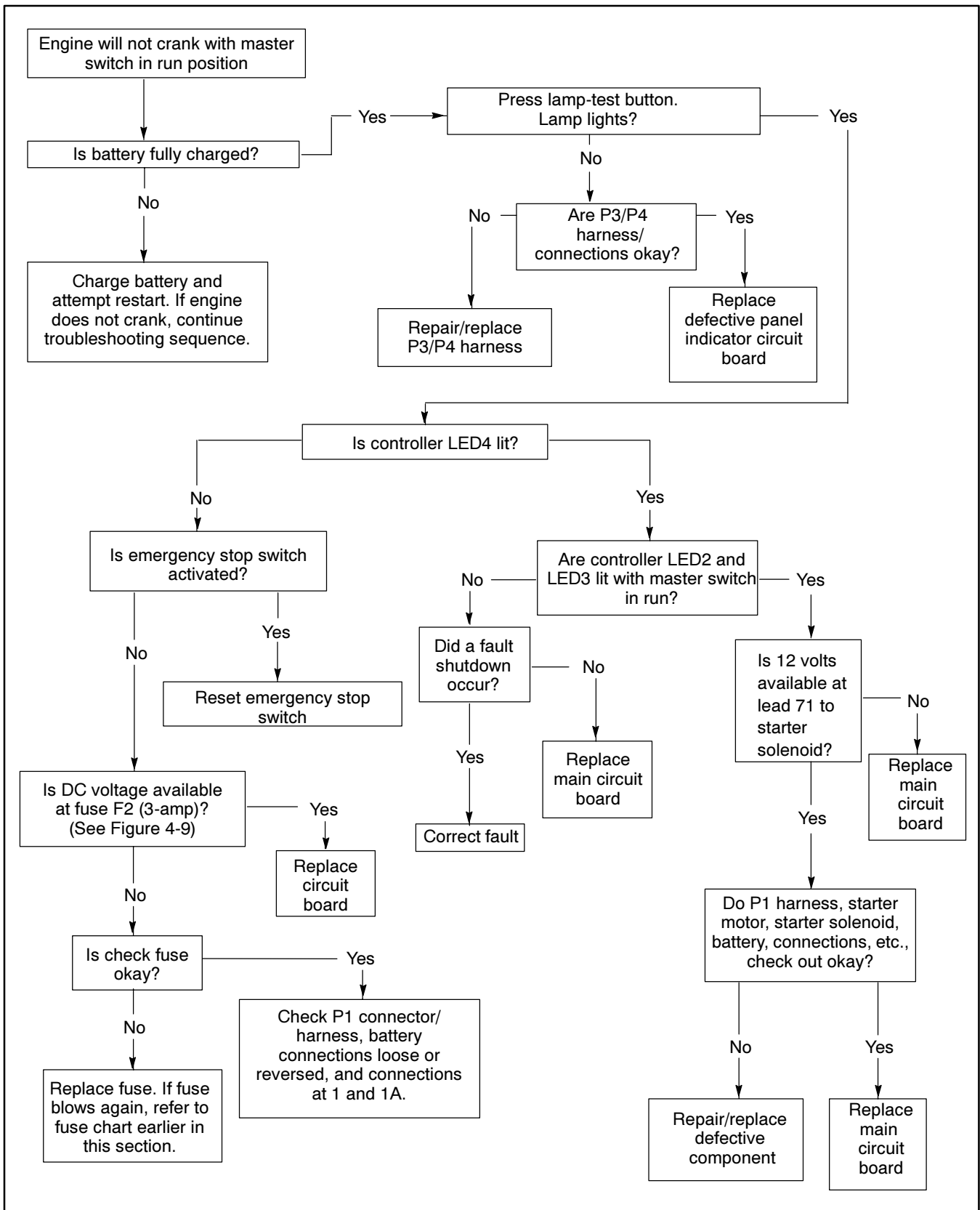

Figure 4-17 Troubleshooting Microprocessor Circuit Board (Sheet 1 of 5)

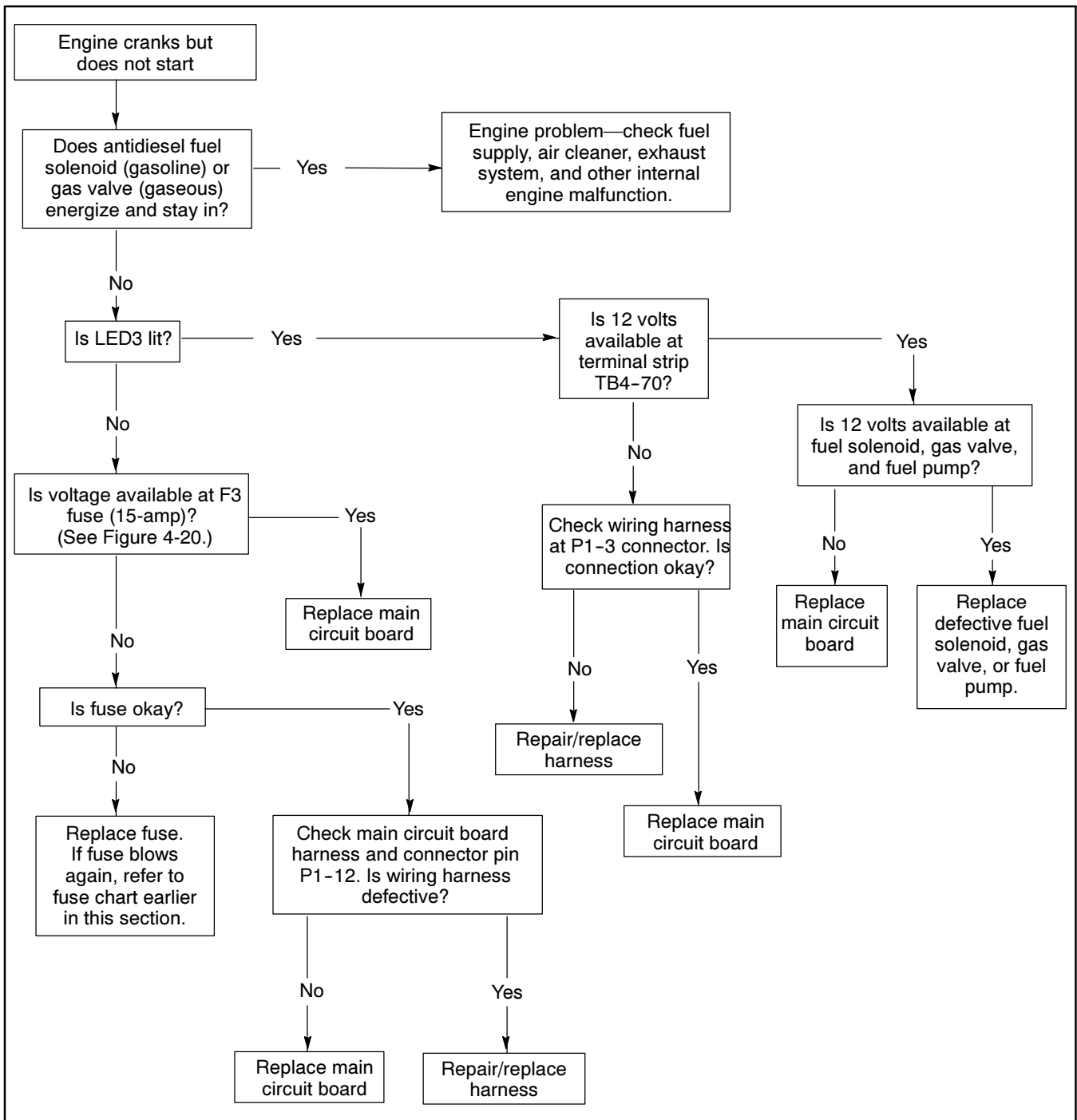

Figure 4-18 Troubleshooting Microprocessor Circuit Board (Sheet 2 of 5)

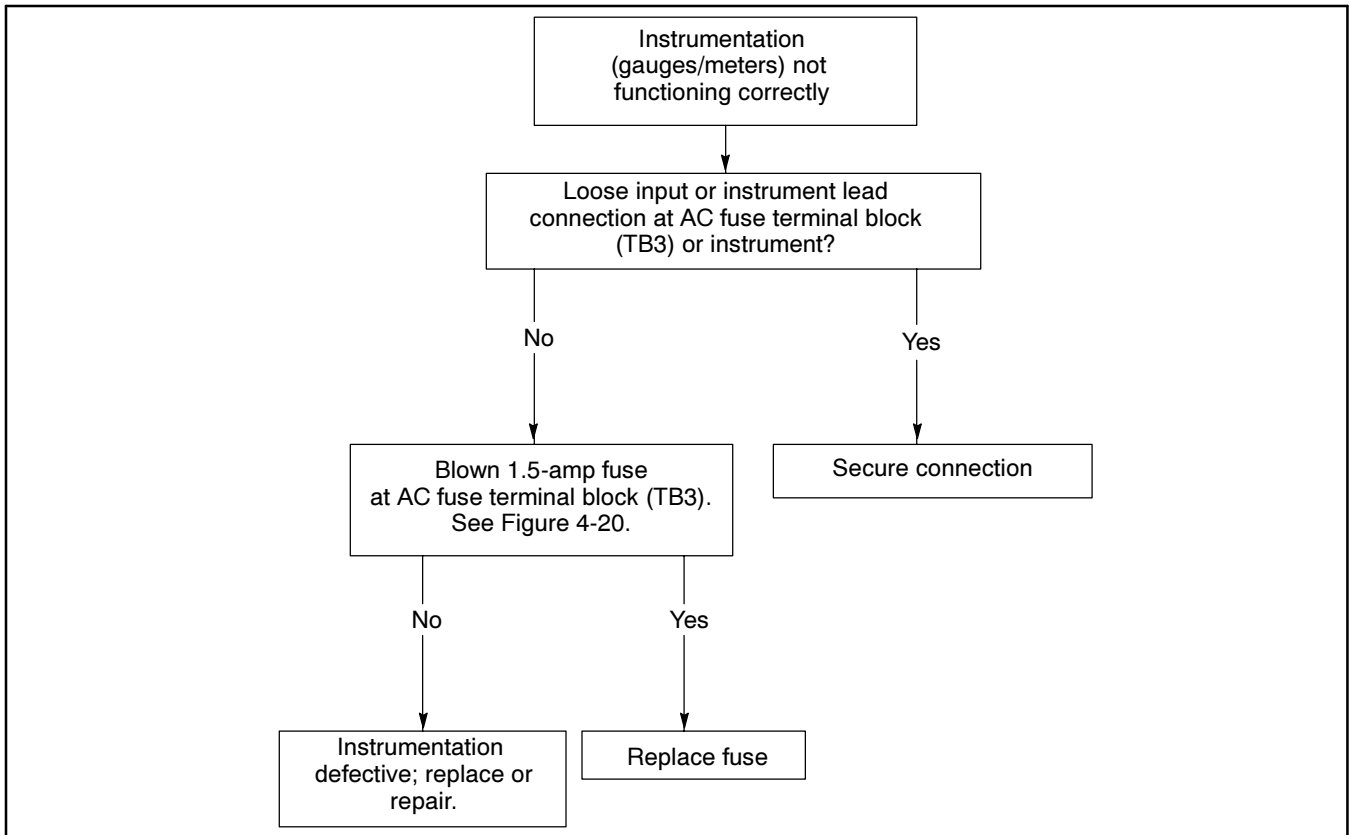

Figure 4-19 Troubleshooting Microprocessor Circuit Board (Sheet 3 of 5)

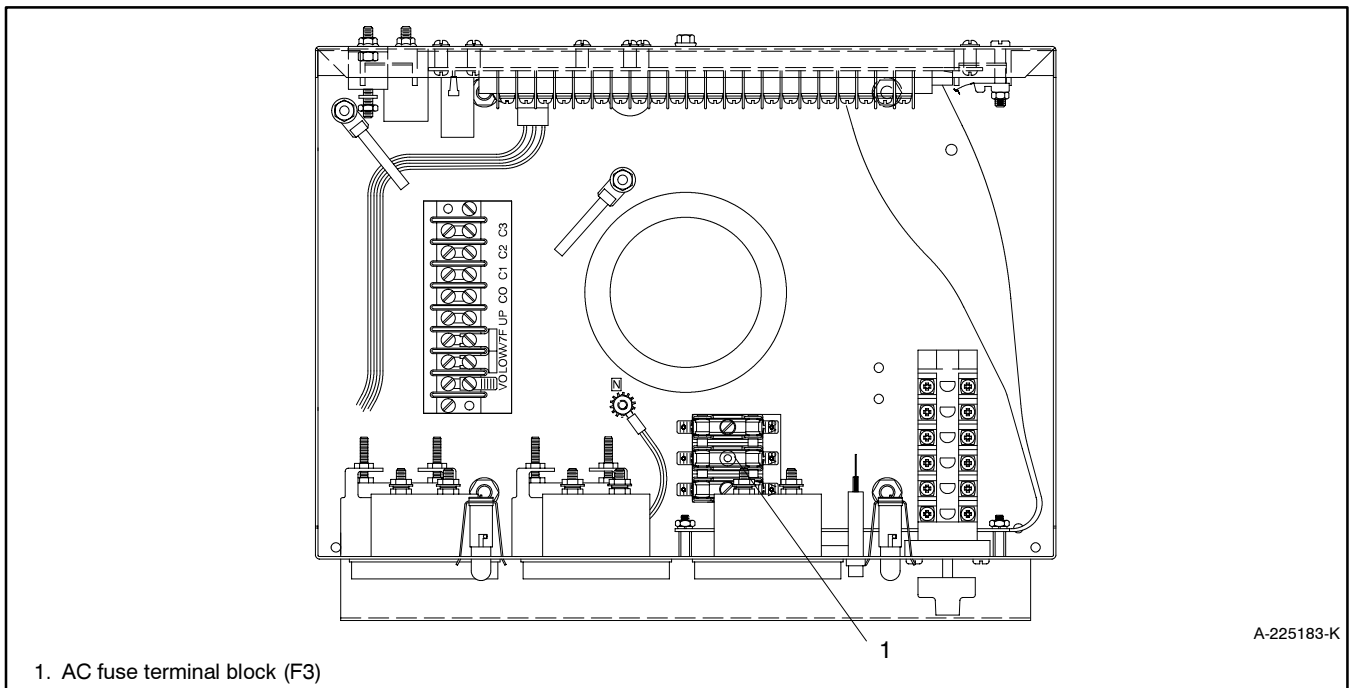

Figure 4-20 Microprocessor Controller AC Fuse Terminal Block (F3)

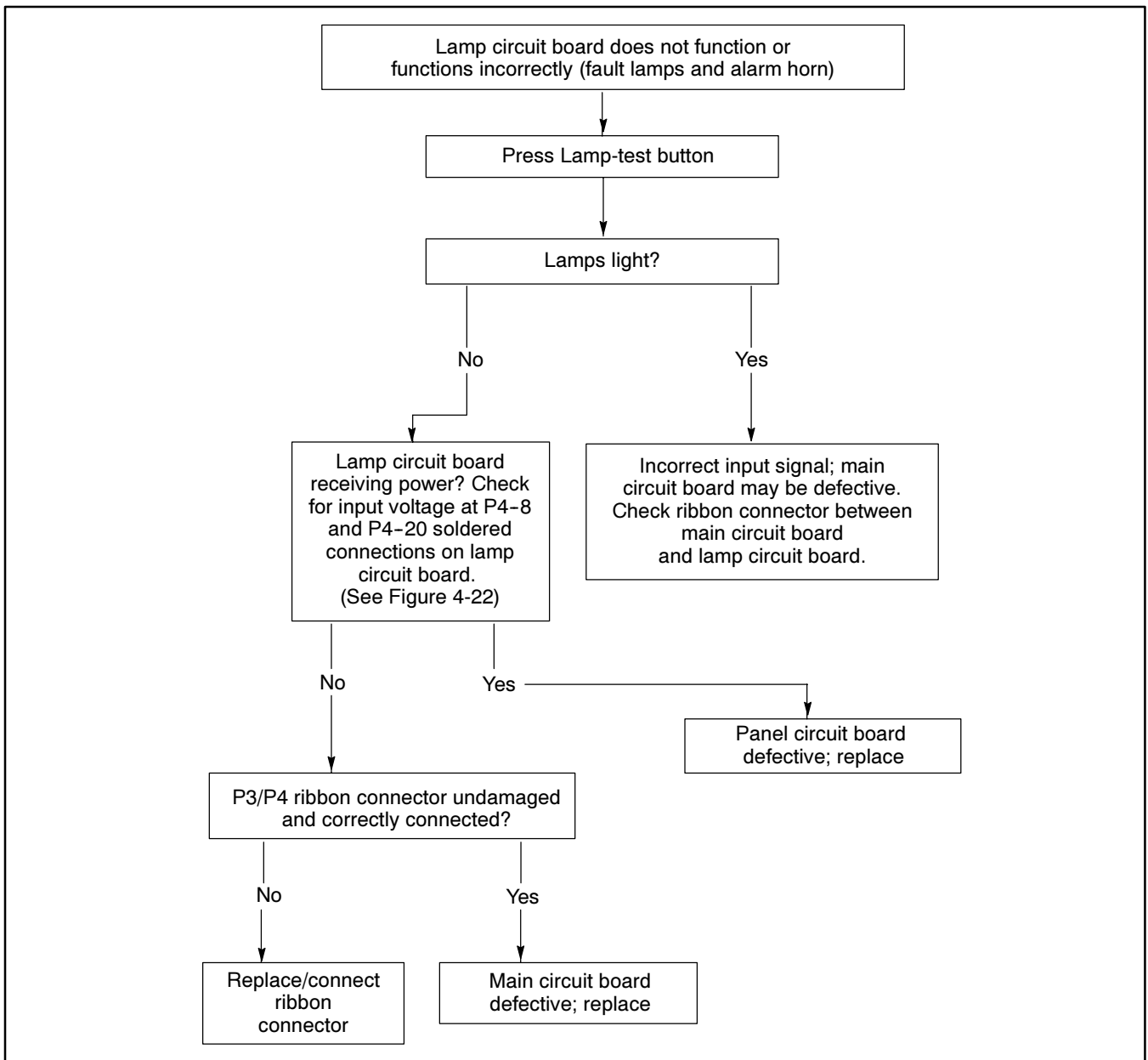

Figure 4-21 Troubleshooting Microprocessor Circuit Board (Sheet 4 of 5)

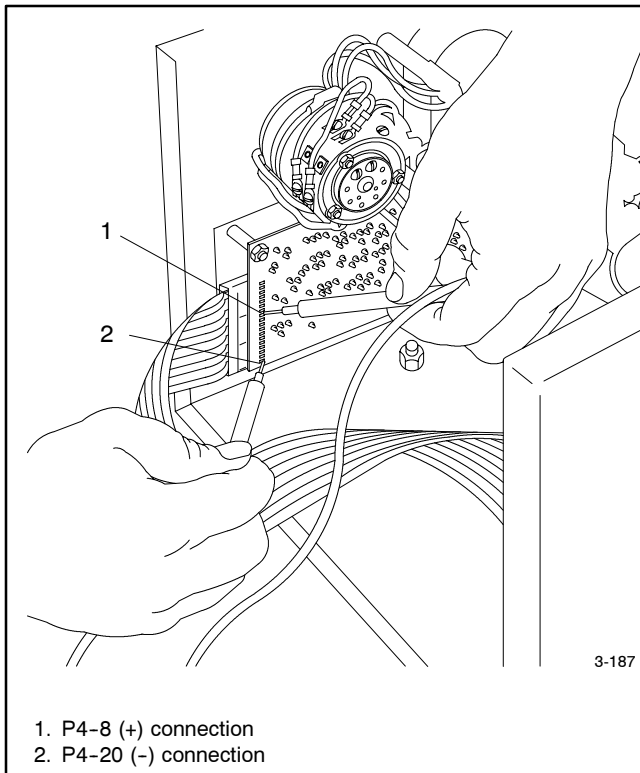

Figure 4-22 Controller Input to Lamp Circuit Board

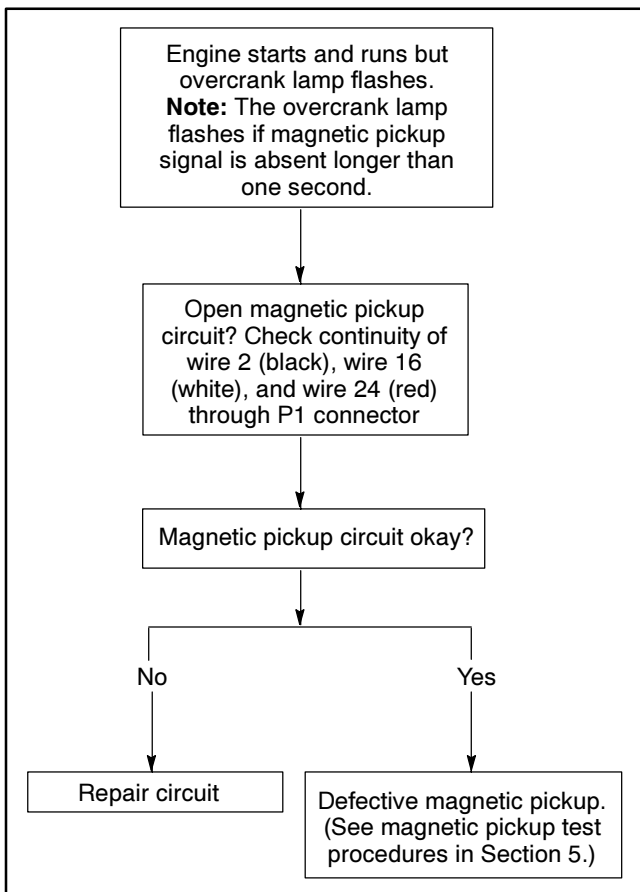

Figure 4-23 Troubleshooting Microprocessor Circuit Board (Sheet 5 of 5)

4.3 FASTCHECK

The FASTCHECK® is an engine simulator for testing and troubleshooting the 5-light microprocessor controller.

4.3.1 Features

The following engine switch positions simulate engine conditions:

- **OFF**—locked engine (starter energized but not turning).
- **CRANK**—engine cranking but not starting.
- **RUN**—engine running.

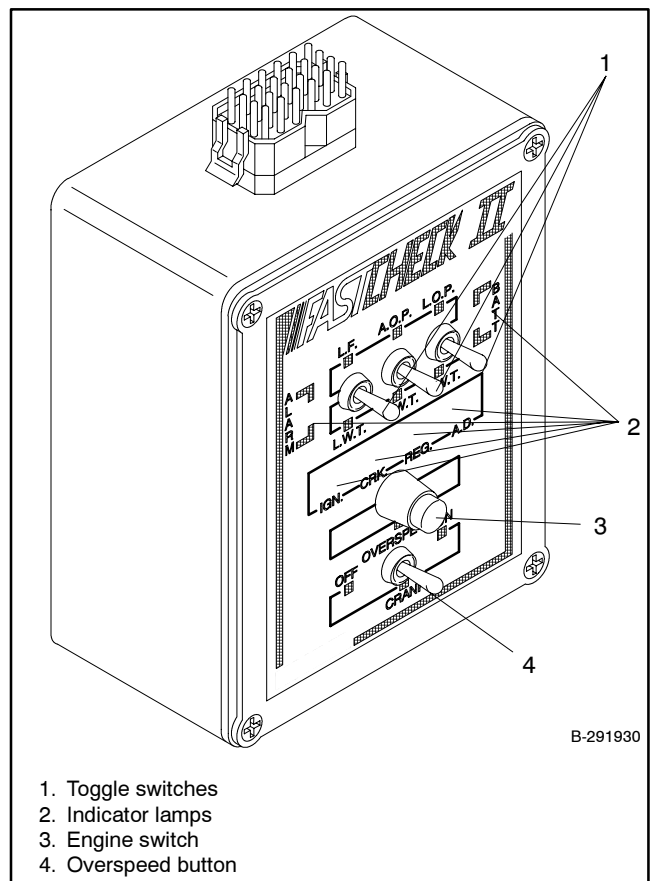

Figure 4-24 FASTCHECK® Simulator

Indicator Lamps

IGN. (ignition) lamp

- shows battery voltage supplied to fuel pump, fuel solenoid, and water valve (city-water cooled sets)
- lights during cranking and running

CRK. (crank) lamp

- shows battery voltage switched to starter (engine not necessarily turning)
- lights only during on-crank cycles

REG. (regulator) lamp

- shows battery voltage supplied to generator's AC voltage regulator
- lights only during cranking and running

BATT. (battery) lamp

- lights when test battery or DC power supply is live and correctly connected.

Note: LOP and OVERSPEED simulate malfunctions causing engine shutdown. LOP circuits start timing after engine has been running for 30 seconds. Engine shutdown should occur 5 seconds after pressing fault switch.

Switches

LOP—low oil pressure

HWT—high water (engine) temperature (not used)

OVERSPEED—simulates a 70 Hz overspeed condition

LF—low fuel (not used for testing)

LWT—low engine water temperature (not used)

ALOP—anticipatory (pre) low oil pressure

AWT—anticipatory high water temperature (not used)

4.3.2 Operation

Use the FASTCHECK® to test the 5-light microprocessor controller on the generator set when troubleshooting startup problems or to test and troubleshoot the controller when it is removed from the generator set.

Operating the FASTCHECK® requires the following equipment:

- FASTCHECK® simulator (A-291930) and harness (255915)
- Variable low-voltage DC power supply; 0 to 30 volt, 3-amp minimum current, 0.5% maximum output voltage ripple at 30 volts DC. A 12-volt battery can also be used to operate the FASTCHECK®.

To Connect/Operate the FASTCHECK® Tester

1. Unplug DC engine harness from DC harness connector (P1). See Figure 4-25.
2. Connect FASTCHECK® harness to DC harness connector (P1) and top of FASTCHECK®.
3. Move the generator set master switch to the OFF/RESET position.
4. Move FASTCHECK® engine switch to OFF.
5. Clip red (+) and black (-) harness leads to battery(ies) or DC power supply of correct voltage for generator set (12 volt). The generator set battery(ies) may be used if accessible and fully charged.

Note: Because of the absence of AC output, the LOW WATER TEMP/AUXILIARY lamp flashes during controller testing.

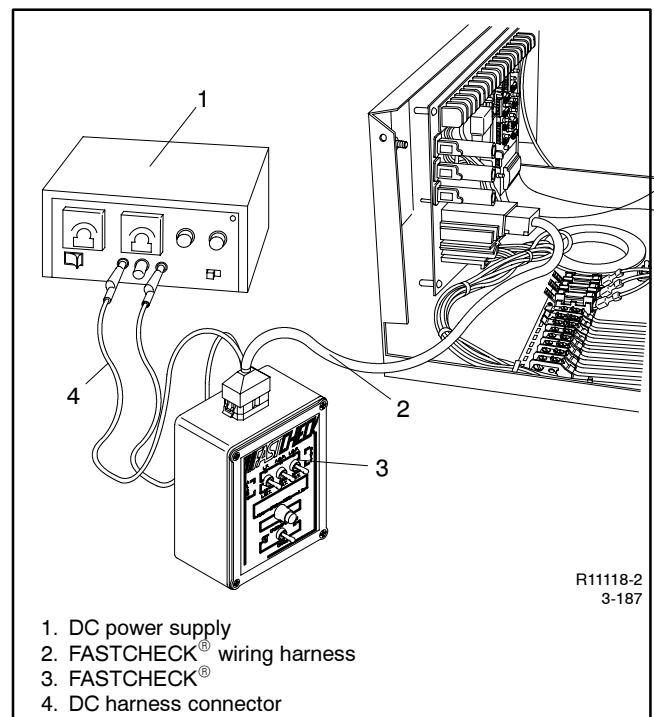

Figure 4-25 FASTCHECK® Connections

6. Move FASTCHECK® engine switch to CRANK. FASTCHECK® IGN., CRK., and REG. lamps should light. FASTCHECK® simulates cyclic cranking (15 seconds on, 15 seconds off, 15 seconds on, etc.) until engine switch is moved to RUN or OVERCRANK shutdown appears on FASTCHECK®.
7. Move the FASTCHECK® engine switch to RUN. CRK. lamp should go out and REG. and IGN. lamps should stay lit.
8. Simulate engine malfunctions by pressing FASTCHECK® fault switches. Corresponding fault lamp on controller should light during each simulated engine malfunction.

Note: Leave the FASTCHECK® engine switch in RUN position for at least 30 seconds before pushing toggle switches. Toggle generator set master switch to OFF/RESET and FASTCHECK® engine switch to OFF, then back to RUN after simulated fault shutdowns.

Procedures to test overcrank circuitry, speed sensor circuitry, and generator condition indicators are described later in this section.

Overcrank

To test the controller's ability do the following:

- Detect a locked engine.
- Stop a startup attempt if the starter locks or will not engage.

Use the following procedure to verify operation of the overcrank circuit.

1. Move FASTCHECK® engine switch to OFF.

2. Move generator set master switch to OFF and then move switch to RUN.
3. IGN., CRK., and REG. lamps on FASTCHECK® should light for approximately 5 seconds and then go out. After 5 seconds the IGN., CRK., and REG. lamps should relight for 5 seconds before going out again (15 seconds total elapsed time). Controller OVERCRANK lamp lights. Check for operating voltage between TB1-42A (+) and TB1-12 (-).
4. This test verifies the operation of the entire overcrank circuit. If the OVERCRANK shutdown fails to function, check the speed sensor and related circuitry.

Controller Speed Sensor Circuitry

To test speed sensor output, refer to Section 5.13, Magnetic Pickup. To check the controller's ability to respond to signals from the magnetic pickup, perform the following test:

1. Move the generator set master switch to the OFF/RESET position.
2. Move FASTCHECK® engine switch to OFF position.
3. Move generator set master switch to the RUN position. Observe IGN., CRK., and REG. lamps light.
4. Within 5 seconds, move FASTCHECK® engine switch to RUN.
5. If CRK. lamp goes out on FASTCHECK®, the controller speed sensor circuitry is functioning.

TB1 Terminal Strip

Connect remote accessories (audiovisual alarm, Decision monitor, alarm contact kits, etc.) to the controller TB1 terminal strip to signal the condition of the generator set. The generator set may not be equipped with the sending devices necessary to operate all generator condition indicators. If remote accessories will not operate, test for output voltage at the TB1 terminal strip. To test the operation of each indicator, move the generator set master switch and FASTCHECK® engine switch to the positions indicated in chart following. Check for voltage at the prescribed test points with the FASTCHECK® toggle in the position prescribed. Test point voltage should be slightly less than the voltage being supplied to the controller (12 volts). If correct voltage is not detected at the test point, remote accessories (audiovisual alarm, Decision Monitor™, dry contact kits, etc.) will not function. Figure 4-26 shows test point connections.

Note: When checking controller test point voltage, place negative (-) lead of voltmeter on terminal designated in the chart and voltmeter positive (+) lead on TB1-42A.

Note: Because of the absence of AC output, the Low Water Temperature/AUX. lamp flashes during controller testing.

Note: Leave FASTCHECK® engine switch in the RUN position for at least 30 seconds before pushing toggle switches. Toggle generator set master switch to OFF/RESET position. Move the FASTCHECK® engine switch to OFF position. Move generator set master switch to RUN position. Observe IGN., CRK., and REG. lamps light. Within 5 seconds, move the FASTCHECK® engine switch to RUN.

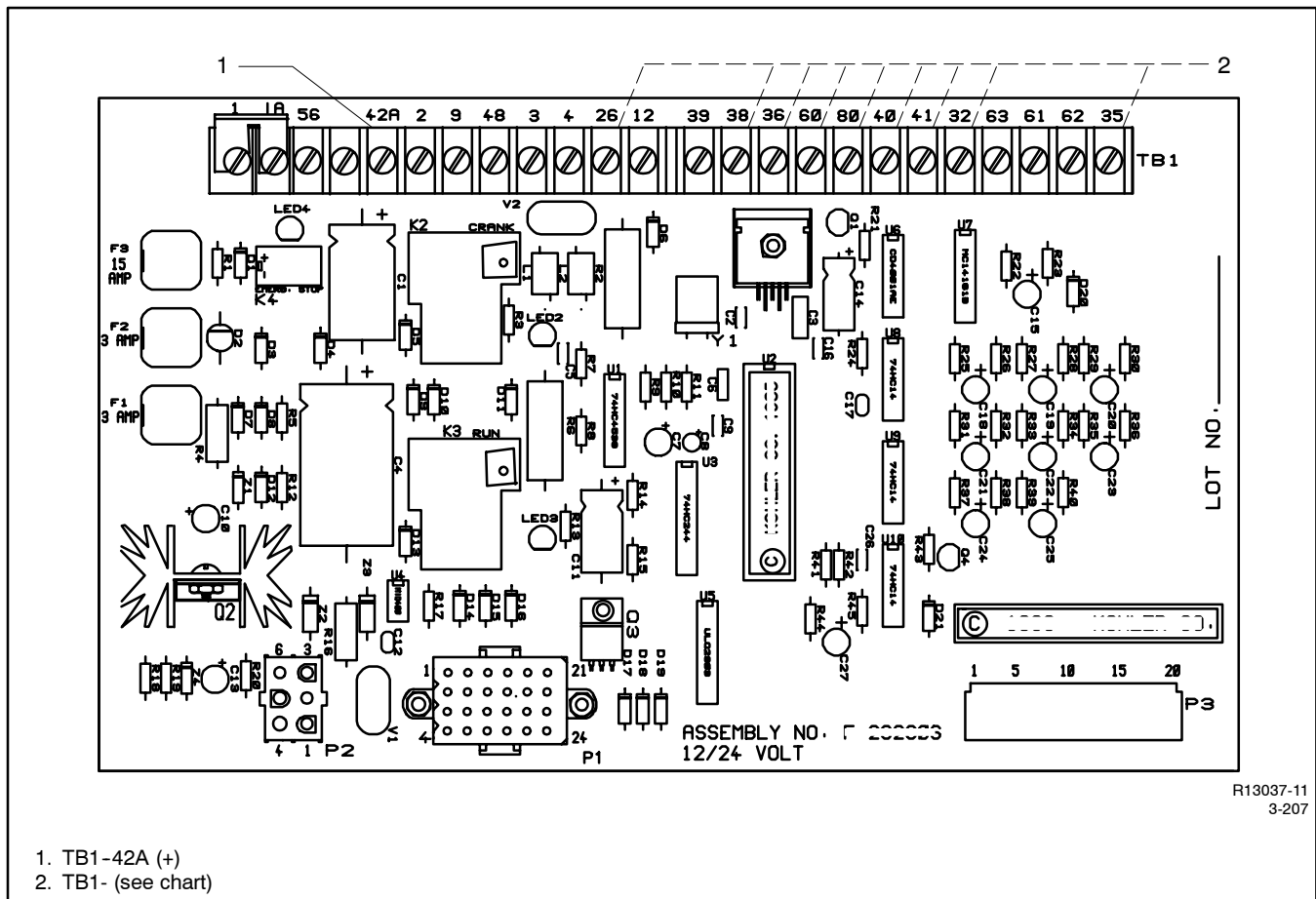

Figure 4-26 Indicator Lamp Test Connections

Indicator	Switch Position/Remarks	Check Voltage Between:
System Ready	Generator set master switch in AUTO position; engine switch in OFF position.	TB1-42A (+) and TB1-60 (-)
High Engine Temperature (HET)	Generator set master switch in RUN position; engine switch in RUN position; hold toggle switch to HWT for at least 5 seconds.	TB1-42A (+) and TB1-36 (-)
Low Oil Pressure (LOP)	Generator set master switch in RUN position; engine switch in RUN position; hold toggle switch to LOP for at least 5 seconds.	TB1-42A (+) and TB1-38 (-)
Auxiliary (AUX)	Generator set master switch in RUN position; engine switch in RUN position; wait 10 seconds. Flashing AUX lamp indicates proper operation of all auxiliary functions.	TB1-42A (+) and TB1-26 (-)
Low Water Temperature (LWT)	Generator set master switch in RUN position; engine switch in RUN; hold toggle switch to LWT.	TB1- 42A (+) and TB1-35 (-)
Emergency Stop (Local/Remote)	Generator set master switch in RUN position; engine switch in RUN position; remove switch lead connected to controller terminals TB1-1 or 1A.	Not Applicable
Not-In-Auto	Generator set master switch in RUN or OFF/RESET; engine switch in any position.	TB1-42A (+) and TB1-80 (-)
Pre-High Engine Temperature	Generator set master switch in RUN position; engine switch in RUN; hold toggle to AWT.	TB1-42A (+) and TB1-40 (-)
Pre-Low Oil Pressure (AOP)	Generator set master switch in RUN position; engine switch in RUN; hold toggle to AOP.	TB1-42A (+) and TB1-401(-)
Low Fuel	Generator set master switch in OFF/ RESET; engine switch in RUN position. Ground controller terminal TB1-63 to test. If Low Fuel lamp lights, circuit is functioning.	Not Applicable
Battery Charger Fault, if Battery Charger Equipped	Generator set master switch in OFF/ RESET; engine switch in RUN position. Ground controller terminal TB1-61 to test. If Battery Charger lamp lights, circuit is functioning.	Not Applicable
Low Battery Volts, if Battery Charger Equipped	Generator set master switch in OFF/ RESET; engine switch in RUN position. Ground controller terminal TB1-62 to test. If Low Battery Volts lamp lights, circuit is functioning.	Not Applicable
Common Fault Line	Generator set master switch in RUN position; engine switch in RUN; hold toggle switch to LWT, HWT, or LOP.	TB1-42A (+) and TB1-32 (-)
Overspeed	See Controller Speed Sensor Circuitry in Section 4.3.2.	Not Applicable
Overcrank	See Overcrank in Section 4.3.2.	Not Applicable

Figure 4-27 Terminal Strip Testing

Notes

Section 5 Component Testing and Adjustment

Use this section as a guide for checking generator components for incorrect operation and performing component adjustment. Refer to Section 3, General Troubleshooting, to determine which component may be defective. Follow the safety precautions at the beginning of this manual during all test procedures. Additional safety precautions are included with the tests; **OBSERVE THESE PRECAUTIONS!**

Note: When working with the starter relay, the following terminal lead identifiers may be used: K20, K1, or K5.

Note: When working with the field flashing relay the following terminal lead identifiers may be used: K21, K6, or K5.

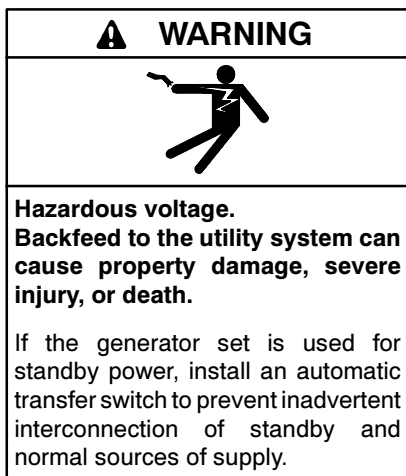
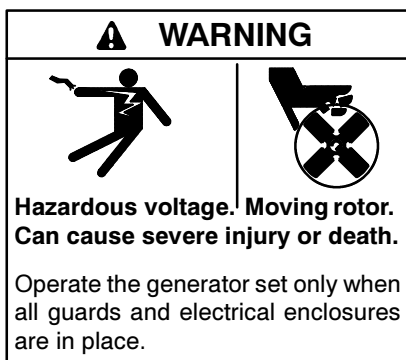

Grounding electrical equipment. Hazardous voltage can cause severe injury or death. Electrocutation is possible whenever electricity is present. Open the main circuit breakers of all power sources before servicing the equipment. Configure the installation to electrically ground the generator set, transfer switch, and related equipment and electrical circuits to comply with applicable codes and standards. Never contact electrical leads or appliances when standing in water or on wet ground because these conditions increase the risk of electrocution.

Disconnecting the electrical load. Hazardous voltage can cause severe injury or death. Disconnect the generator set from the load by opening the line circuit breaker or by disconnecting the generator set output leads from the transfer switch and heavily taping the ends of the leads. High voltage transferred to the load during testing may cause personal injury and equipment damage. Do not use the safeguard circuit breaker in place of the line circuit breaker. The safeguard circuit breaker does not disconnect the generator set from the load.

High voltage test. Hazardous voltage can cause severe injury or death. Follow the instructions of the test equipment manufacturer when performing high-voltage tests on the rotor or stator. An improper test procedure can damage equipment or lead to generator set failure.

Short circuits. Hazardous voltage/current can cause severe injury or death. Short circuits can cause bodily injury and/or equipment damage. Do not contact electrical connections with tools or jewelry while making adjustments or repairs. Remove all jewelry before servicing the equipment.

Testing the voltage regulator. Hazardous voltage can cause severe injury or death. High voltage is present at the voltage regulator heat sink. To prevent electrical shock do not touch the voltage regulator heat sink when testing the voltage regulator.

(PowerBoost™, PowerBoost™ III, and PowerBoost™ V voltage regulator models only)

5.1 Theory of Operation, 1- and 3-Phase Generators with PowerBoost III E and V

The 1- and 3-phase models utilize a rotating field generator to produce AC current. When the start switch is activated, the rotor (field) is magnetized by DC current from the battery. When the magnetized rotor rotates within the stator windings, an electrical current develops within the stator. As engine speed and generator output increase, stator output current (rectified by the voltage regulator) feeds to the rotor through the brushes/slip rings to increase the strength of the rotor field. As the rotor field increases in strength, generator output also increases. The voltage regulator monitors the generator output voltage through leads 33 and 44 on 1-phase models and through leads 7 and 8 on 3-phase models and regulates DC current flow to the rotor to meet load requirements. See Figure 5-1 or Figure 5-2.

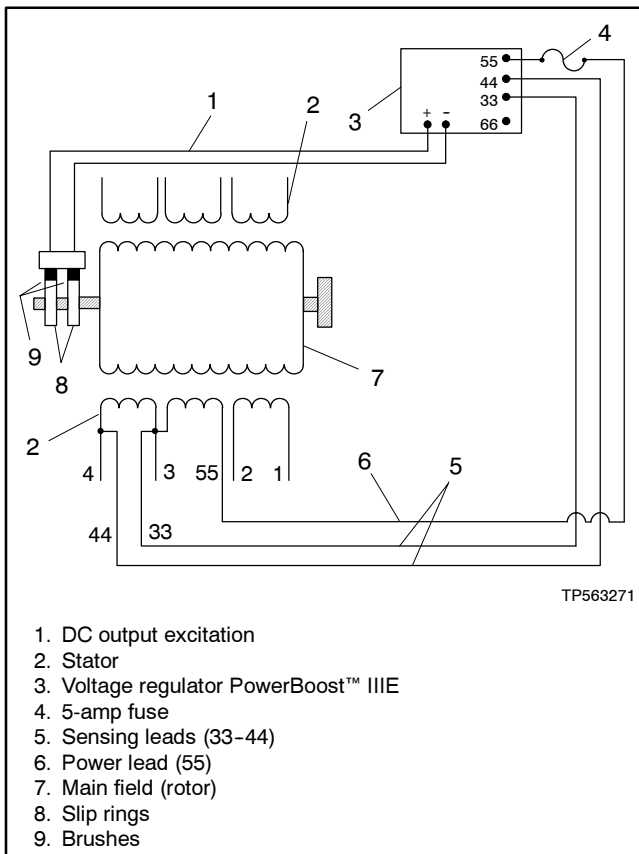

Figure 5-1 1-Phase (4-lead) Generator Schematic

5.2 Theory of Operation, 12-Lead (Brushless) Generators

The 12-lead models utilize a wound field brushless excited generator to produce AC current. When the start switch is activated, the exciter field is magnetized by DC current from the battery. When the exciter armature rotates within the magnetized exciter field windings, an electrical current develops within the exciter armature. As the engine speeds up, exciter armature output increases. Current from the exciter armature (converted to DC by the rectifier module) magnetizes the generator main field.

The main field rotating within the stator windings imparts AC current in the stator windings. As the main field increases in strength (as supplied by exciter armature), generator output also increases. The voltage regulator monitors output voltage through stator leads 7 and 10 to regulate DC current (rectified by the voltage regulator) to the exciter field to meet the generator load requirements. Stator windings 55 and 66 through the voltage regulator supply exciter field current (other than startup).

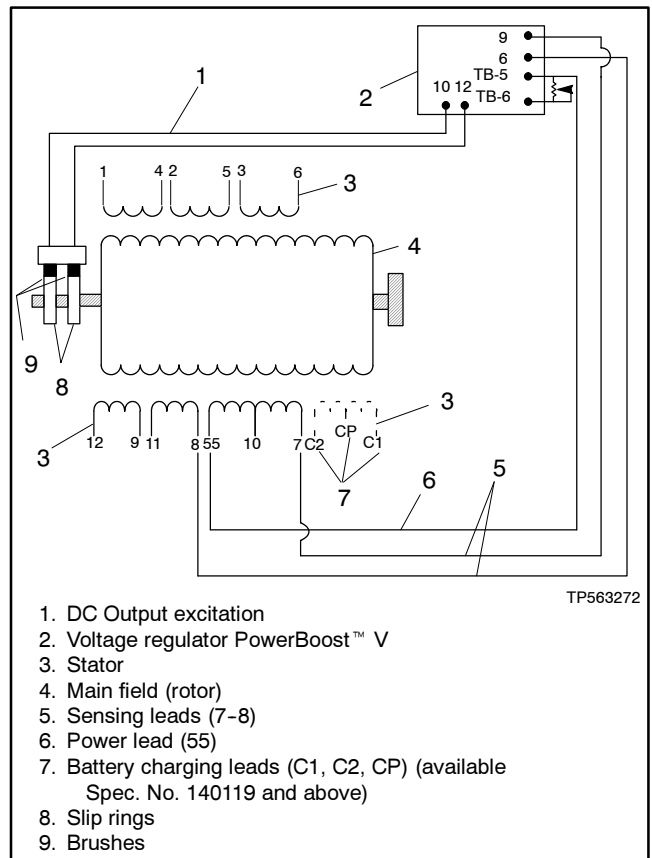

Figure 5-2 3-Phase (12-lead) Generator Schematic

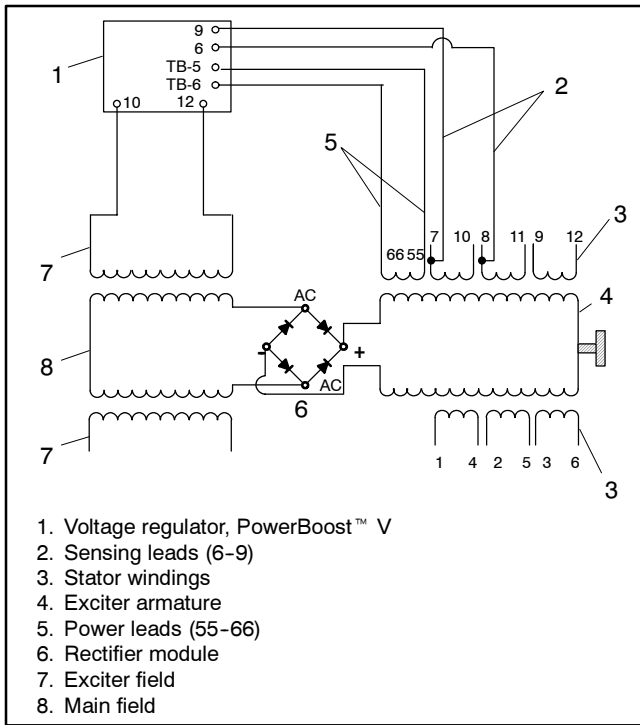

Figure 5-3 12-Lead (Brushless) Generator Schematic (RZ/RFZ Shown)

5.3 Separate Excitation

5.3.1 4-Lead Generator Sets

Determine the cause of no or low AC output by referring to the troubleshooting flow chart (Figure 5-4) and the separate excitation procedure following. Before beginning the troubleshooting procedures, read all safety precautions at the beginning of this manual. The following tests include additional safety precautions; **OBSERVE THESE PRECAUTIONS!**

Begin the troubleshooting procedure by checking the condition of the voltage regulator 10-amp fuse. See the operation manual, Section 2 (for fuse location) and Section 5, Component Testing and Adjustment. If the fuse is good, separately excite the generator. Excite (magnetize) the generator field (rotor) using an outside power source (12-volt automotive battery). The separate excitation test duplicates the role of the voltage regulator in providing excitation current to the rotor.

By separately exciting the generator to determine the presence of a faulty voltage regulator, it is possible to determine if a running fault exists in the rotor and/or stator. A generator component that appears good while static (stationary) may exhibit a running open or short circuit while dynamic (moving). Short circuits can be

caused by centrifugal forces acting on the windings during rotation or insulation breakdown as temperatures increase. The flow chart in Figure 5-4 summarizes the troubleshooting procedure.

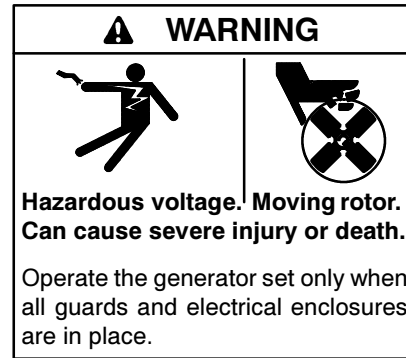

Grounding electrical equipment. Hazardous voltage can cause severe injury or death. Electrocutation is possible whenever electricity is present. Open the main circuit breakers of all power sources before servicing the equipment. Configure the installation to electrically ground the generator set, transfer switch, and related equipment and electrical circuits to comply with applicable codes and standards. Never contact electrical leads or appliances when standing in water or on wet ground because these conditions increase the risk of electrocution.

Short circuits. Hazardous voltage/current can cause severe injury or death. Short circuits can cause bodily injury and/or equipment damage. Do not contact electrical connections with tools or jewelry while making adjustments or repairs. Remove all jewelry before servicing the equipment.

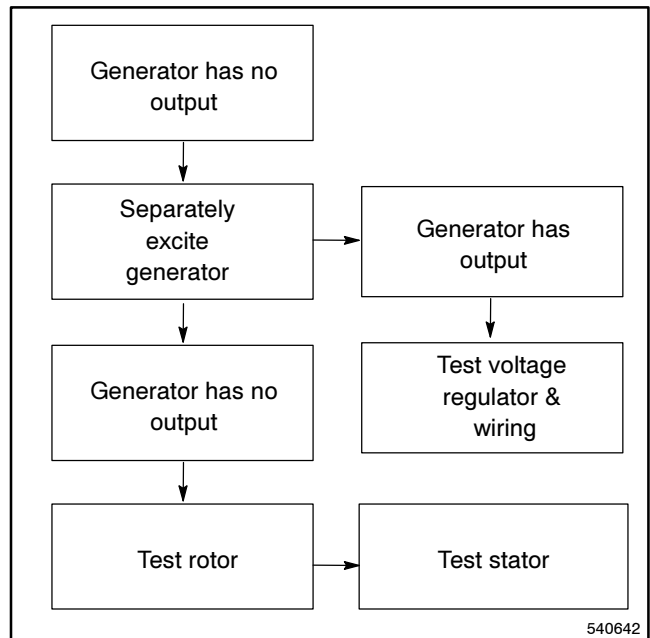

Figure 5-4 General Troubleshooting, RY/RFY 4-Lead Generators

4-Lead Separate Excitation Procedure

1. Disconnect all leads from voltage regulator.
2. Connect a DC ammeter, 10-amp fuse, and a 12-volt automotive battery to the positive (+) and negative (-) brush leads as shown in Figure 5-7. Note and record the ammeter reading.
3. The approximate ammeter reading should be battery voltage divided by specified main field (rotor) resistance. See Section 1, Specifications.
4. Start engine and check that ammeter remains stable. An increasing meter reading indicates a shorted rotor. A decreasing meter reading to zero or unstable reading suggests a running open circuit. Refer to Section 5.10, Rotor, for testing the rotor. If ammeter is stable proceed to step 5.
5. Check for AC-output across stator leads and compare to readings in Figure 5-6. If readings vary considerably from those in Figure 5-6, a faulty stator is likely. Refer to Section 5.11, Stator, for more information.
6. If rotor and stator test good in prior steps, the voltage regulator is probably defective.

Example: 10RY Generator

$$\frac{12 \text{ Volts (Battery Voltage)}}{4 \text{ Ohms (Rotor Resistance)}} = 3 \text{ amps Rotor Current}$$

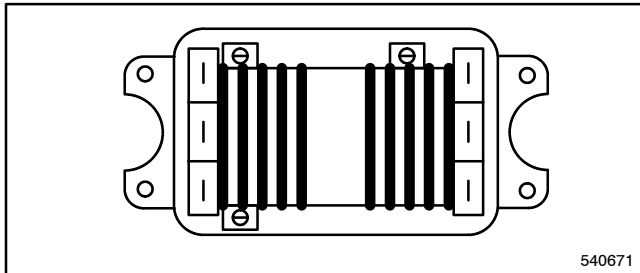

Figure 5-5 PowerBoost™ III Voltage Regulator

Leads	Volts		
	10RY/RFY	12RY/RFY	18RY/RFY
1-2, 3-4, 33-44	80-100	70-90	70-90
33-55	110-150	108-140	110-140

Figure 5-6 Stator Output Voltages with Separately Excited Rotor (12-Volt Battery)

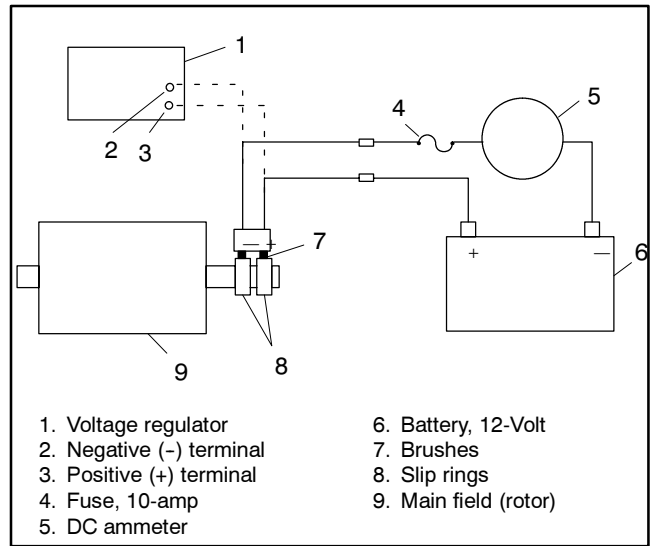

Figure 5-7 Separate Excitation Connections

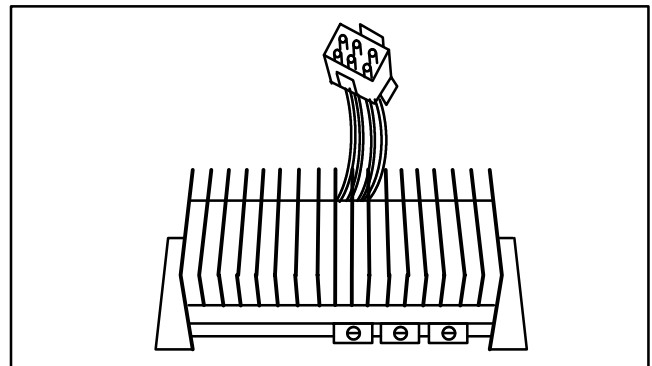

Figure 5-8 PowerBoost™ IIIE Voltage Regulator

5.3.2 12-Lead Generator Sets

Determine the cause of no or low AC output on 12-lead generators by referring to the troubleshooting flow chart (Figure 5-9) and the separate excitation procedure following. Before beginning the troubleshooting procedures, read all safety precautions at the beginning of this manual. The following tests include additional safety precautions; **OBSERVE THESE PRECAUTIONS!**

Begin the troubleshooting procedure by separately exciting the exciter field. The exciter field may be excited (magnetized) using an outside power source (12-volt automotive battery). During the separate excitation test, you will be duplicating the role of the voltage regulator by providing excitation current to the exciter field.

By separately exciting the exciter field to determine the presence of a faulty voltage regulator, you can determine if a running fault exists in the rotor. A generator component that appears good while static (stationary) may exhibit a running open or short circuit while dynamic (moving). This fault can be caused by centrifugal forces acting on the windings while rotating or insulation breakdown as temperatures increase. The flow chart in Figure 5-9 summarizes the troubleshooting procedure.

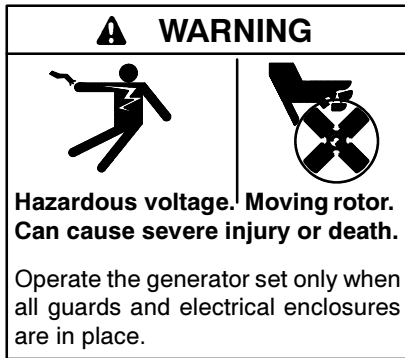

Grounding electrical equipment. Hazardous voltage can cause severe injury or death. Electrocutation is possible whenever electricity is present. Open the main circuit breakers of all power sources before servicing the equipment. Configure the installation to electrically ground the generator set, transfer switch, and related equipment and electrical circuits to comply with applicable codes and standards. Never contact electrical leads or appliances when standing in water or on wet ground because these conditions increase the risk of electrocution.

Short circuits. Hazardous voltage/current can cause severe injury or death. Short circuits can cause bodily injury and/or equipment damage. Do not contact electrical connections with tools or jewelry while making adjustments or repairs. Remove all jewelry before servicing the equipment.

12-Lead Separate Excitation Procedure

1. Disconnect all leads from voltage regulator. See Figure 5-10.
2. Remove exciter field F1 and F2 leads from terminal strip TB1 (relay controller) or TB4 (5-light controller).
3. Connect separate excitation circuit as shown in Figure 5-11. Connect an ammeter and a 10-amp fuse in series with F1. Note and record the ammeter reading.

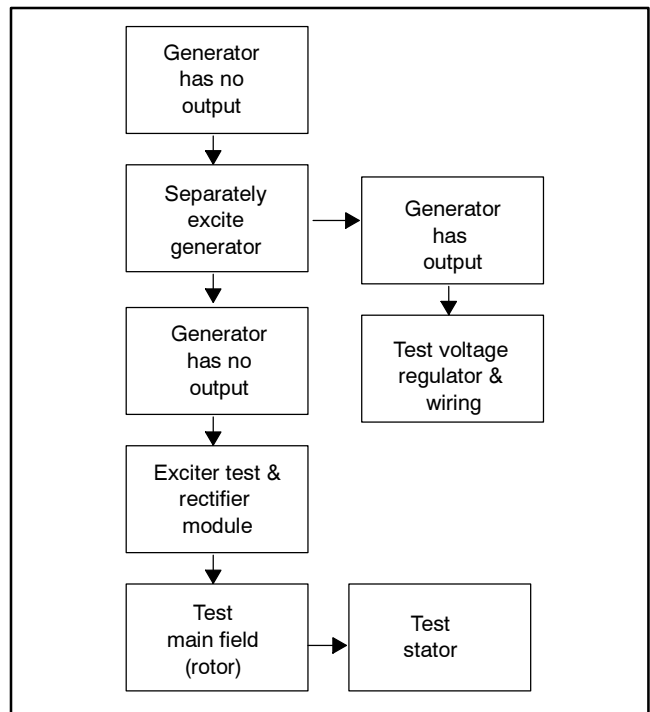

Figure 5-9 Generator Troubleshooting, RZ/RFZ 12-Lead Generators

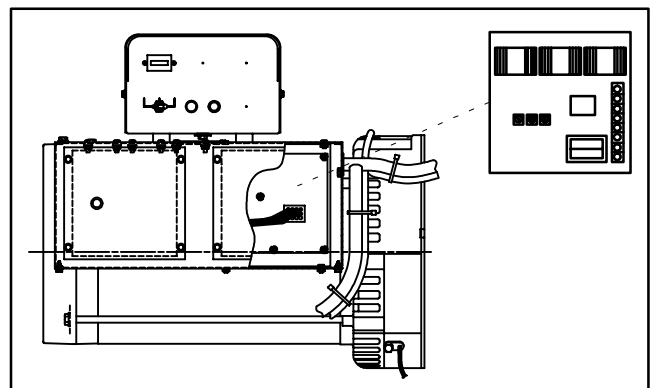

Figure 5-10 PowerBoost™ V Voltage Regulator

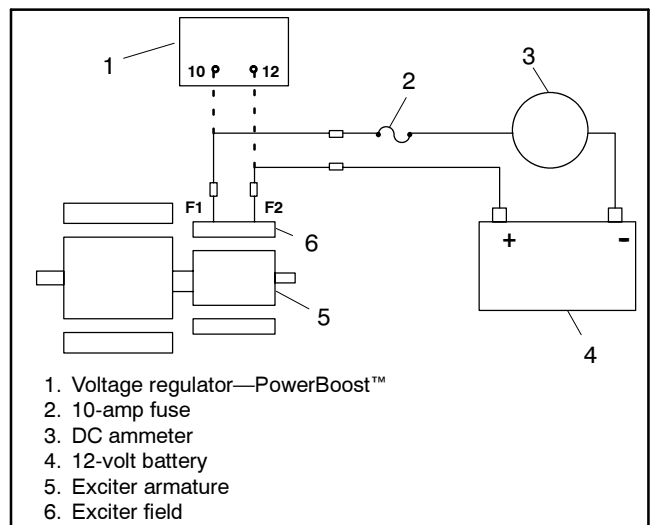

Figure 5-11 Separate Excitation Connections

- Calculate the approximate ammeter reading by dividing battery voltage by specified rotor resistance. Specified rotor resistance for 10/12RZ/RFZ generator sets is approximately 7 ohms.

Example: 10RZ Generator

$$\frac{12 \text{ Volts (Battery Voltage)}}{7 \text{ Ohms (Exciter Resistance)}} = 1.7 \text{ Amps (Exciter Current)}$$

- Start engine and check that ammeter remains stable. An increasing meter reading indicates a shorted rotor. A decreasing meter reading to zero or unstable reading suggests a running open. Refer to Component Testing and Adjustment in this section. If ammeter is stable, proceed to step 6.
- Check for AC output across stator leads and compare to readings in Figure 5-12. If readings vary considerably from those in Section 1, Specifications, a faulty stator is likely. Refer to Section 5.11, Stator, for further information.
- If rotor and stator test good in prior steps, the voltage regulator is probably defective. If there is no generator output during normal operation but output is available when the set is separately excited, the voltage regulator is probably defective.

Note: Disconnect F1/F2 leads from terminal strip before separate excitation.

5.4 Voltage Regulator

5.4.1 PowerBoost III and IIIE Voltage Regulator

Early model generators were equipped with PowerBoost™ III voltage regulators; later models were equipped with PowerBoost™ IIIE regulators. Refer to Figure 5-13 and Figure 5-14 to identify the voltage regulator used in the set being serviced. The following text notes differences in test/adjustment procedures.

The voltage regulator monitors output voltage magnitude and frequency to supply current to the generator exciter field. If the regulator 10-amp fuse is blown, the generator shuts down. Verify that regulator fuse is good before proceeding with test.

When frequency drops below 57.5/47.5 Hz, AC voltage should decline. Perform the following test to check regulator output. Use the following components to test the voltage regulator:

- Variable transformer, 0–140V (0.5-amp minimum)
- 120-volt AC plug
- 120-volt, 100-watt lamp
- AC voltmeter
- #14 AWG Insulated copper wire (minimum)

Leads	10RZ/RFZ V	12RZ/RFZ V	18RZ/RFZ V
1-4, 2-5, 3-6, 7-10, 8-11, 9-12	210	170	170
55-66	230	180	180

Figure 5-12 Stator Output Voltages with Separately Excited 12-Lead Generator (12-V Battery)

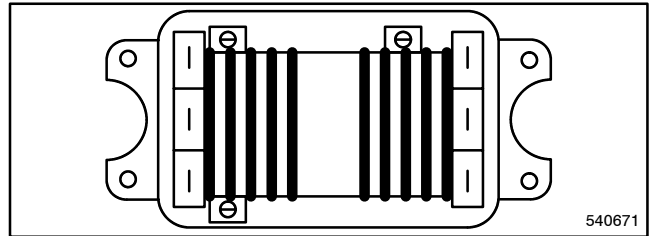

Figure 5-13 PowerBoost™ III Voltage Regulator

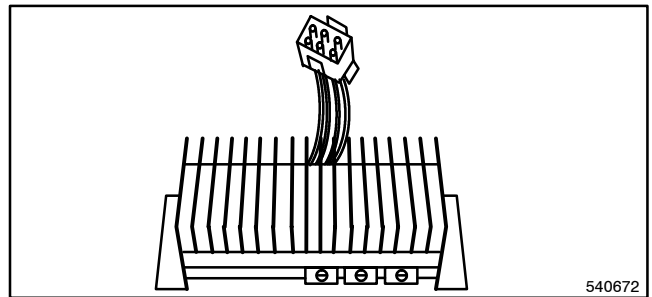

Figure 5-14 PowerBoost™ IIIIE Voltage Regulator

⚠ WARNING

Hazardous voltage. Backfeed to the utility system can cause property damage, severe injury, or death.

If the generator set is used for standby power, install an automatic transfer switch to prevent inadvertent interconnection of standby and normal sources of supply.

Grounding electrical equipment. Hazardous voltage can cause severe injury or death. Electrocutation is possible whenever electricity is present. Open the main circuit breakers of all power sources before servicing the equipment. Configure the installation to electrically ground the generator set, transfer switch, and related equipment and electrical circuits to comply with applicable codes and standards. Never contact electrical leads or appliances when standing in water or on wet ground because these conditions increase the risk of electrocution.

High voltage test. Hazardous voltage can cause severe injury or death. Follow the instructions of the test equipment manufacturer when performing high-voltage tests on the rotor or stator. An improper test procedure can damage equipment or lead to generator set failure.

Short circuits. Hazardous voltage/current can cause severe injury or death. Short circuits can cause bodily injury and/or equipment damage. Do not contact electrical connections with tools or jewelry while making adjustments or repairs. Remove all jewelry before servicing the equipment.

Test Procedure

1. Connect components as shown in Figure 5-15 or Figure 5-16.
2. Turn variable transformer setting to zero. Plug in variable transformer.
3. Turn variable transformer on. Slowly increase variable transformer voltage to 100 volts. The lamp should light. If the lamp does not light, turn the voltage adjustment potentiometer clockwise. If the lamp still does not light, the voltage regulator is defective. Replace it. A voltage regulator which tests bad causes a generator no/low output condition.
4. Slowly increase voltage to 120 volts. The lamp should go out and stay out as voltage further increases. If the lamp remains lit, turn the voltage adjustment potentiometer counterclockwise. If the lamp still remains lit, replace the voltage regulator. A voltage regulator which tests bad causes a generator high voltage output condition.

5. Turn variable transformer to zero and unplug AC cord.

Note: For applications requiring fine voltage adjustment connect a remote rheostat to voltage regulator terminal 66.

Adjustment Procedure

PowerBoost™ III and IIIE voltage regulators monitor generator output to control current flow to the generator field. PowerBoost™ IIIE maintains generator output at specified voltage under load until the generator engine speed drops to a preset level of 57.5 Hz on 60 Hz models and 47.5 Hz on 50 Hz models. At this point the regulator allows generator voltage and current to drop. The voltage/current drop enables the engine to pick up the load. When the generator speed returns to normal (60 Hz or 50 Hz) as load is accepted, generator output also returns to normal.

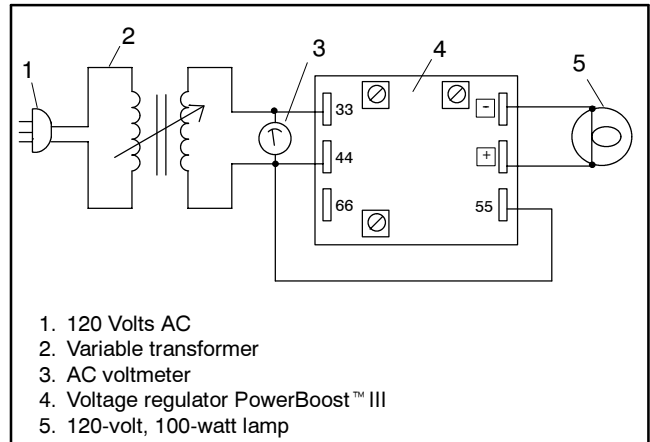

Figure 5-15 PowerBoost™ III Voltage Regulator Test

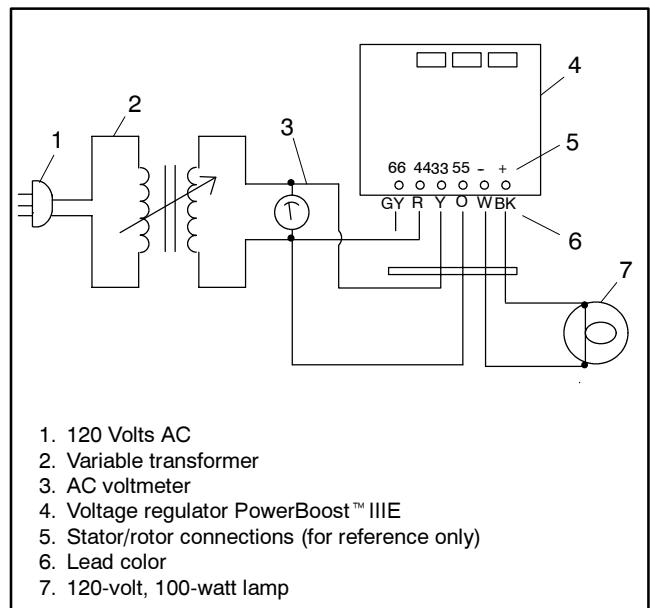

Figure 5-16 PowerBoost™ IIIE Voltage Regulator Test

The voltage regulator is factory set for correct generator operation under a variety of load conditions. Usually, no further adjustment is necessary. However, if regulator adjustment is necessary to achieve 50 Hz voltage, or if the regulator has been replaced or tampered with, readjust according to the following procedure. See Figure 5-13 and Figure 5-14 for voltage regulator locations. See Figure 5-17 and Figure 5-18 for regulator components and the following paragraphs.

Voltage Adjustment Potentiometer adjusts generator output within range of 100–130 volts.

Note: Connect a customer-provided rheostat across regulator leads/terminals 33 and 66 to adjust generator output voltage from a location remote from the set. The rheostat (10 kOhms, 1/2 watt minimum) provides a 5-volt adjustment range.

Stabilizer Potentiometer fine-tunes regulator circuitry to reduce light flicker.

Volts/Hz Potentiometer adjustment determines engine speed (Hz) at which generator output voltage begins to drop.

⚠ WARNING

<p>Hazardous voltage. Backfeed to the utility system can cause property damage, severe injury, or death.</p> <p>If the generator set is used for standby power, install an automatic transfer switch to prevent inadvertent interconnection of standby and normal sources of supply.</p>

Testing the voltage regulator. Hazardous voltage can cause severe injury or death. High voltage is present at the voltage regulator heat sink. To prevent electrical shock do not touch the voltage regulator heat sink when testing the voltage regulator.

(PowerBoost™, PowerBoost™ III, and PowerBoost™ V voltage regulator models only)

Short circuits. Hazardous voltage/current can cause severe injury or death. Short circuits can cause bodily injury and/or equipment damage. Do not contact electrical connections with tools or jewelry while making adjustments or repairs. Remove all jewelry before servicing the equipment.

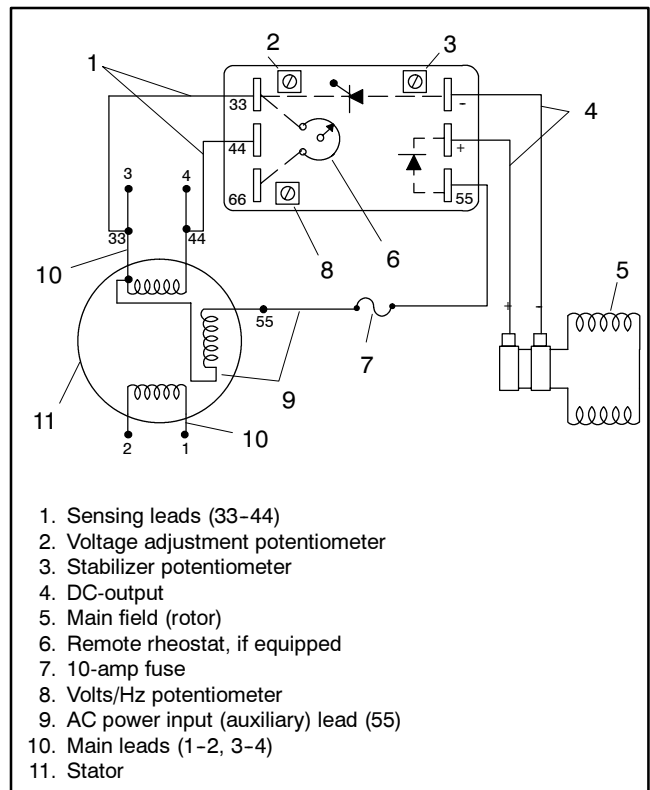

Figure 5-17 PowerBoost™ III Voltage Regulator

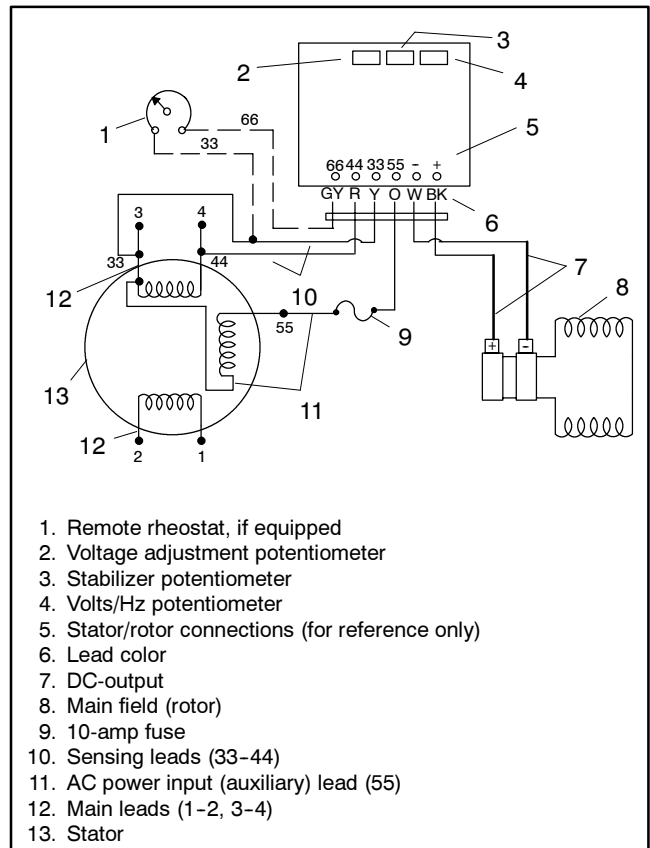

Figure 5-18 PowerBoost™ IIIIE Voltage Regulator

1. With generator set off, turn remote rheostat, if equipped, to midpoint. Turn voltage, volts/Hz, and stability potentiometers fully counterclockwise. Connect voltmeter to AC circuit or an electrical outlet.
2. Start generator set. Rotate voltage adjustment potentiometer clockwise to increase voltage or counterclockwise to decrease voltage to achieve desired output voltage.
3. Rotate stability potentiometer clockwise to obtain minimum light flicker.
4. Readjust voltage adjustment potentiometer if necessary.
5. Adjust engine speed to desired cut-in frequency by installing a jumper on the electronic governor circuit board -2.5 Hz/FREQ terminals. With a jumper across these terminals, generator frequency drops by 2.5 Hz. The recommended cut-in frequency is 57.5 Hz for 60 Hz operation and 47.5 Hz for 50 Hz operation as measured on frequency meter.
6. Rotate volts/Hz adjustment potentiometer clockwise until voltage level as measured on voltmeter begins to drop. When set to the specifications in step 5, the generator attempts to maintain normal output as load is applied until engine speed drops below the frequency set in step 5.
7. Remove jumper from governor circuit board -2.5 Hz/FREQ terminals.
8. Readjust voltage adjustment potentiometer if necessary.
9. Readjust stability potentiometer if necessary.
10. Use remote rheostat, if equipped, to make final voltage adjustments.
11. Stop the generator set.

5.4.2 PowerBoost V Voltage Regulator

The PowerBoost™ V voltage regulator monitors output voltage magnitude and frequency to supply current to the generator exciter field. See Figure 5-19. LEDs offer a visual indication of sensing, input power, and field output availability.

Perform the following test to check regulator output. Use the following components to test the voltage regulator:

- 1:2 Step-up transformer (0.5-amp minimum)
- 120 volt AC plug (240 volt ac optional)
- 250 volt, 100-watt lamp
- AC voltmeter (250 volt minimum)
- #14 AWG copper wire (minimum)

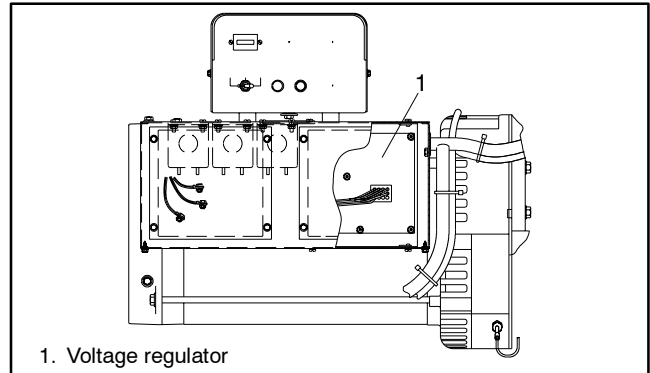
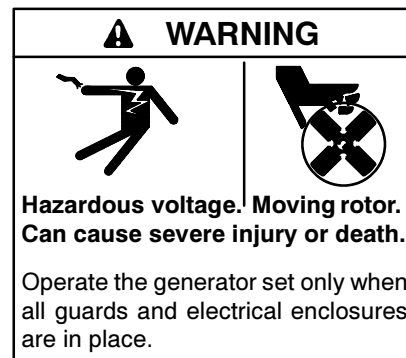

Figure 5-19 PowerBoost™ V Voltage Regulator



Short circuits. Hazardous voltage/current can cause severe injury or death. Short circuits can cause bodily injury and/or equipment damage. Do not contact electrical connections with tools or jewelry while making adjustments or repairs. Remove all jewelry before servicing the equipment.

Grounding electrical equipment. Hazardous voltage can cause severe injury or death. Electrocutation is possible whenever electricity is present. Open the main circuit breakers of all power sources before servicing the equipment. Configure the installation to electrically ground the generator set, transfer switch, and related equipment and electrical circuits to comply with applicable codes and standards. Never contact electrical leads or appliances when standing in water or on wet ground because these conditions increase the risk of electrocution.

A- and B- Board Identification

To determine the version voltage regulator installed on the generator set see Figure 5-20. The visual differences include terminal strip identification and assembly part number identification.

Test Procedure, 240 Volt A- or B-Board

Note: Test regulator field for a maximum of 1-minute with a 5-minute cooldown period.

1. Connect components as shown in Figure 5-21. If a 200-240-volt power source is available, the step-up transformer is not required.
2. If plug (item 10) is 250 volts, use 250 volt lamp. If plug is 120 volts, use 120 volt lamp.
3. Turn volts potentiometer fully clockwise.
4. Set variac to zero or minimum volt.
5. Plug power cord into outlet.

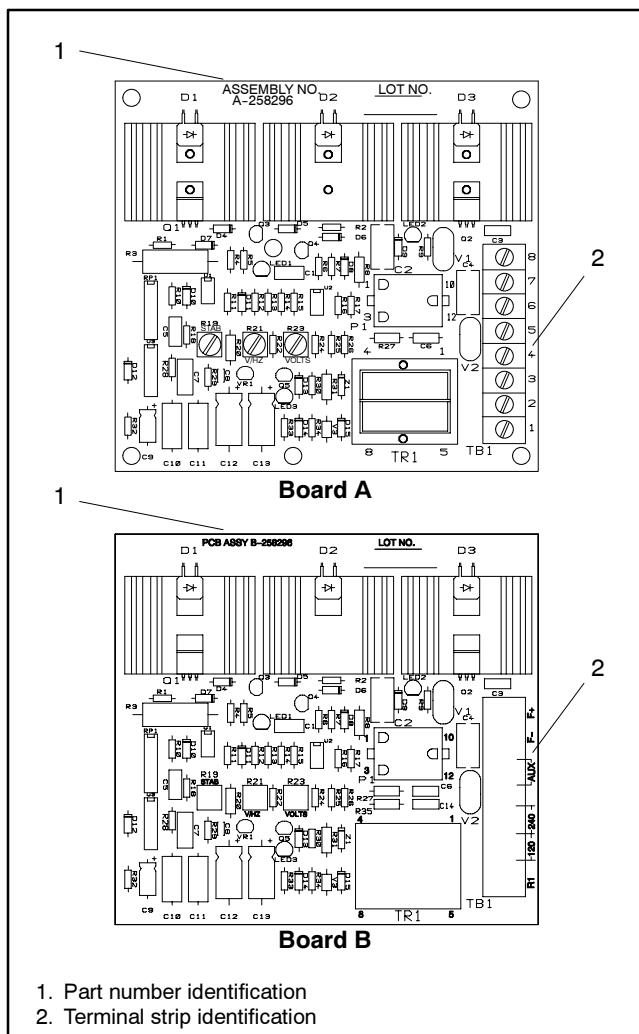

Figure 5-20 PowerBoost™ V Voltage Regulator Boards

6. Turn power variac on. AC voltmeter should indicate power supply voltage of zero volts. Lamp should be off.
7. Slowly increase variac. Light should begin to illuminate at approximately 90 volts.
8. Adjust variac to 240 volts. Do not exceed 300 volts. The lamp should illuminate brightly. If the lamp does not illuminate, the voltage regulator is defective and needs replacing.
9. Turn volts potentiometer fully counterclockwise. The lamp should go out. If it remains lit, the voltage regulator is defective.
10. Turn volts potentiometer clockwise. Lamp should be lit.
11. Turn power supply off and disconnect power cord.
12. See Voltage Regulator Adjustment Procedure.

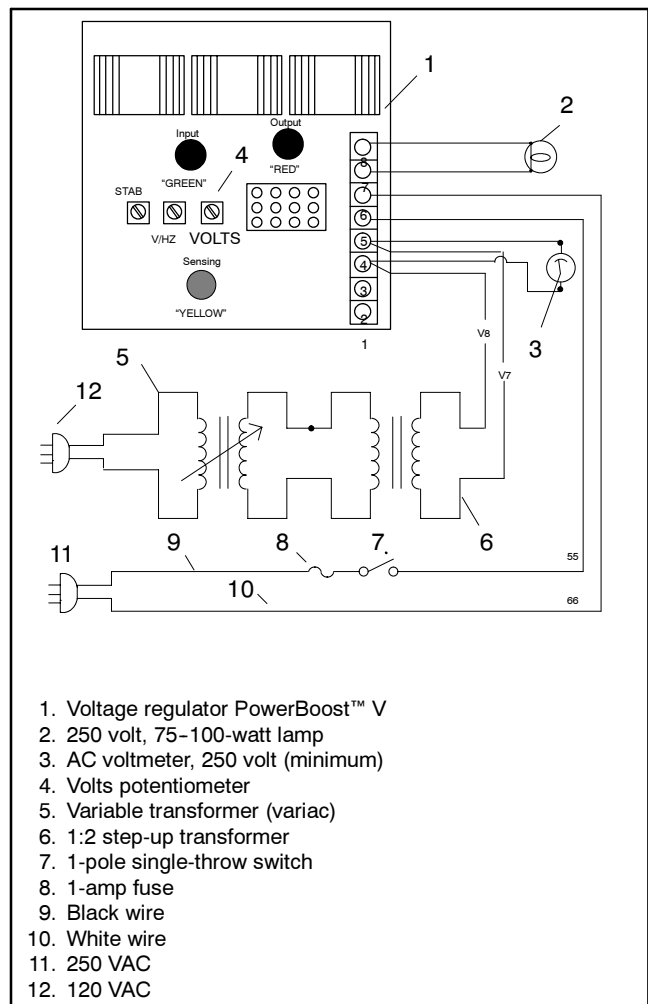

Figure 5-21 Voltage Regulator A-Board

Test Procedure, 120 Volt B-Board

Note: Test regulator field for a maximum of 1 minute with a 5-minute cooldown period.

1. Connect components as shown in Figure 5-22.
2. Turn volts potentiometer fully clockwise.
3. Set variac to zero or minimum volt.
4. Plug power cord into outlet.
5. Turn power variac on. AC voltmeter should indicate power supply voltage of zero volts. Lamp should be off.
6. Slowly increase variac. Lamp should begin to illuminate at approximately 60 volts.
7. Adjust variac to 120 volts. Do not exceed 150 volts. The lamp illuminates brightly. If the lamp does not light, the voltage regulator is defective and needs replacing.
8. Turn volts potentiometer fully counterclockwise. The lamp should go out. If the lamp remains lit, the voltage regulator is defective.
9. Turn volts potentiometer clockwise. Lamp should be lit.
10. Turn power supply off and disconnect power cord.
11. See Voltage Regulator Adjustment procedure.

Adjustment Procedure

The PowerBoost™ V voltage regulator monitors generator output to control current flow to the generator field. However, unlike early PowerBoost™ regulators, PowerBoost™ V maintains generator output under load until the generator engine speed drops to the factory setting of 57.5 Hz on 60-Hz models and 47.5 Hz on 50 Hz models. At this point (under factory settings) the regulator allows generator voltage and current to drop to

a level sufficient to handle load. When the generator speed returns to normal (60 Hz or 50 Hz) as load is accepted, generator output also returns to normal. The voltage regulator is factory set for correct generator operation under a variety of load conditions. Under normal circumstances, no further adjustment is necessary. However, if the regulator is replaced or has been tampered with, readjust according to the following procedure.

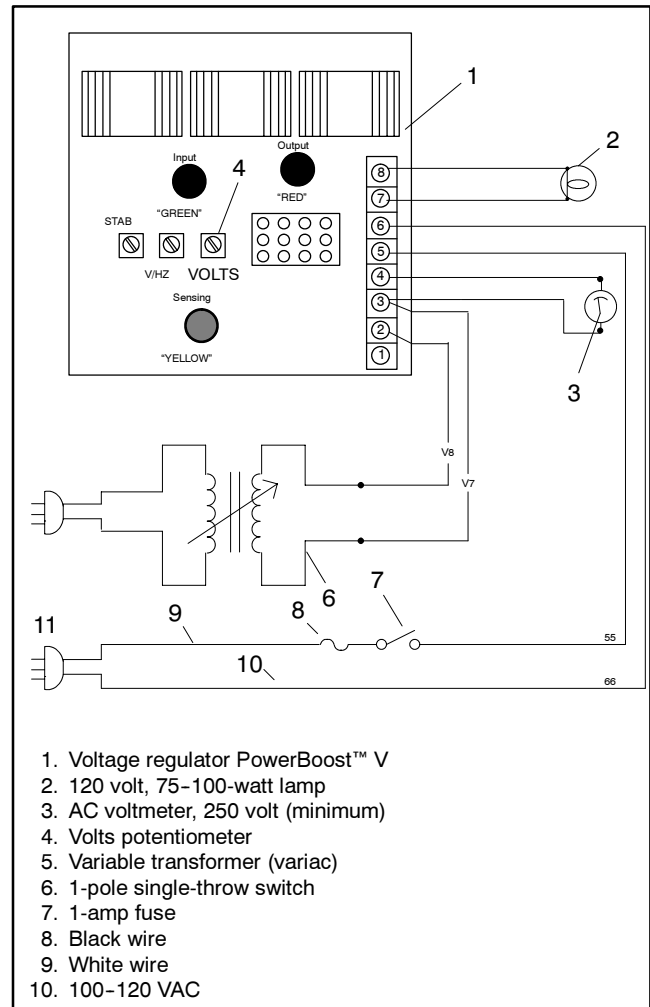

Figure 5-22 Voltage Regulator B-Board

See Figure 5-23, Figure 5-24, and the following paragraphs for voltage regulator components.

Voltage Adjustment Potentiometer adjusts generator output within range of 190–270 volts (line-to-line).

Stabilizer Potentiometer fine-tunes regulator circuitry to reduce light flicker.

Volts/Hz Potentiometer adjustment determines engine speed (Hz) at which generator output voltage will begin to drop.

1. Turn **voltage** and **volts/Hz** potentiometers fully counterclockwise. Connect voltmeter to AC circuit or an electrical outlet.
2. Start generator set. Rotate **voltage adjustment potentiometer** clockwise to increase voltage or counterclockwise to decrease voltage to achieve desired output voltage.
3. Rotate **stability potentiometer** clockwise to obtain minimum light flicker.

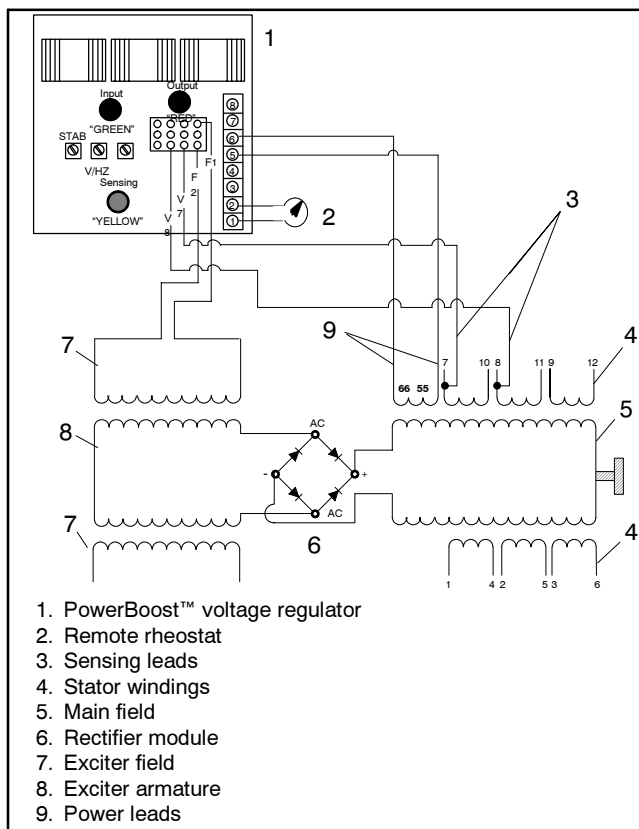

Figure 5-23 PowerBoost™ V Voltage Regulator

4. Recheck output voltage. Readjust **voltage adjustment potentiometer** if necessary.
5. Adjust engine speed to desired cut-in frequency by installing a jumper on the electronic governor circuit board –2.5 Hz/FREQ terminals. See Electronic Governor. With a jumper across these terminals, generator frequency drops by 2.5 Hz. The recommended cut-in frequency is 57.5 Hz for 60 Hz operation and 47.5 Hz for 50 Hz operation as measured on frequency meter.
6. Rotate **volts/Hz adjustment potentiometer** clockwise until voltage level as measured on voltmeter begins to drop. When set to the specifications in step 5, the generator attempts to maintain normal output as load is applied until engine speed drops below the frequency set in Step 5.
7. Remove jumper from governor circuit board –2.5 Hz/FREQ terminals.
8. Readjust **voltage adjustment potentiometer** if necessary.
9. Readjust **stability potentiometer** if necessary.
10. Use remote rheostat (5-light controller only) to make final voltage adjustments.
11. Stop generator set.

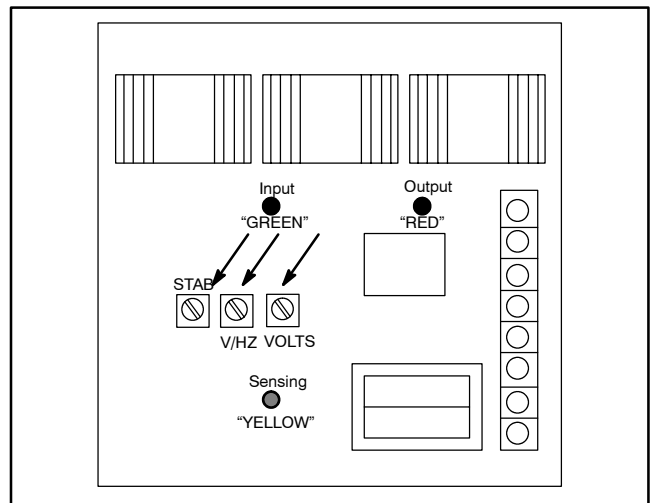

Figure 5-24 PowerBoost™ V Adjustments

5.5 Engine/Generator Components

5.5.1 Relay Controller

With the generator set battery connected, check the wiring harness and some engine/generator components. Place the generator set master switch or

remote start/stop switch in the prescribed position and check for voltage at each component using a voltmeter to verify that the switches function and the presence of voltage at each component. See Figure 5-25 through Figure 5-30 for engine/generator component testing on generator sets with the relay controller.



Component	Voltmeter Connections	Procedure	Results
Hourmeter and wiring	Red test lead to hourmeter positive (+) terminal. Black test lead to hourmeter negative (-) terminal.	Voltmeter setting 12 volts DC or greater. Start generator set.	12-volt DC reading indicates wiring harness is okay. Hourmeter functions if good.
Fault lamp and wiring	Red test lead to hourmeter positive (+) terminal. Black test lead to hourmeter negative (-) terminal.	Voltmeter setting 12 volts DC or greater. Start generator set. Connect a jumper from LOP (low oil pressure) switch to ground to cause LOP shutdown.	12-volt DC reading indicates wiring harness is okay. Fault lamp lights if good.
Stator 1-2 winding (control winding)	V0 and V7 terminals in controller.	Voltmeter setting 50 volts AC or greater. Start generator set and allow it to reach rated speed.	Reading of approximately 120 volts AC indicates stator 1-2 winding is good.
Stator 7-10 winding (1-4 Winding, 600V) (control winding)	V7 and V0 terminals in controller.	Voltmeter setting 250 volts AC or greater. Start generator set and allow it to reach rated speed.	Reading of approximately 120 volts AC indicates stator winding is good.
Choke heater, carburetor solenoid (gasoline units), fuel pump, fuel valve (LP units)	Red test lead to each component positive (+) terminal. Black test lead to engine block ground.	Place controller or remote switch to START position. Voltmeter setting 12 volts DC or greater.	12-volt DC reading indicates wiring harness is okay. To determine if fuel pump, fuel valve (LP), or vaporizer solenoid (LP) is good, proceed to next step. Also see engine components ohmmeter checks following.
Fuel pump (gasoline units only)	None	Disconnect fuel pump battery positive (+) lead and apply 12 volts DC. WARNING: See Safety Precautions before proceeding.	If fuel pump is good, fuel pump operates.
Fuel valve (LP gas only)	None	Disconnect fuel valve battery positive (+) lead and apply 12 volts DC. WARNING: See Safety Precautions before proceeding.	If fuel valve is good, fuel valve actuates; fuel valve makes audible click.
Governor actuator	None	Disconnect actuator harness and apply 12 volts DC to actuator.	If governor actuator is good, actuator thrusts. Actuator returns to relaxed position when DC is removed.
Water temperature gauge, if equipped	Red test lead to positive side of gauge (wire 70). Black test lead to generator ground connection.	Start generator set to test voltage.	Should register Battery voltage of approximately 12 volts DC. If no voltage registers, check controller circuit board and wiring. If voltage is present at gauge, stop set and check continuity of wiring between gauge and ground. Sender resistance will register during continuity check. See Water Temperature Sender in this section. If wiring tests okay, replace gauge.
Oil pressure gauge, if equipped	Red test lead to positive (+) side of gauge (wire 70). Black test lead to generator ground connection.	Start generator set to test voltage.	Should register battery voltage of approximately 12 volts DC. If no voltage registers, check controller circuit board and wiring. If voltage is present at gauge, stop set and check continuity of wiring between gauge and ground. Sender resistance will register during continuity check. See Oil Pressure Sender in this section. If wiring tests okay, replace gauge.
Voltmeter, if equipped	Red test lead to positive (+) side of gauge (wire 70). Black test lead to generator ground connection.	Start generator set.	Should register battery voltage of approximately 12 volts DC. If no voltage registers, check controller circuit board and wiring. If voltage registers, stop set and check continuity of wiring between meter and ground. If wiring tests okay, replace meter.

Figure 5-25 Engine/Generator Component Testing, Relay Controller (Sheet 1 of 4)

To further check generator set components, disconnect the battery and remove wiring harness plugs from the controller circuit board. Use an ohmmeter to check continuity and to isolate defective components. Use Figure 5-17 and the charts in Figure 5-26 and Figure 5-27.

Note: Before performing ohmmeter checks, disconnect generator set battery to prevent damage to the ohmmeter.

Short circuits. Hazardous voltage/current can cause severe injury or death. Short circuits can cause bodily injury and/or equipment damage. Do not contact electrical connections with tools or jewelry while making adjustments or repairs. Remove all jewelry before servicing the equipment.

 WARNING

<p>Hazardous voltage. Backfeed to the utility system can cause property damage, severe injury, or death.</p> <p>If the generator set is used for standby power, install an automatic transfer switch to prevent inadvertent interconnection of standby and normal sources of supply.</p>

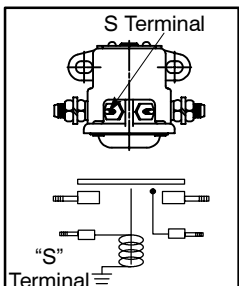
Component	Ohmmeter Connections	Procedure	Results
Generator set master switch	P1-2 (47) and P1-14 (N).	Ohmmeter on R x 1000 scale. Place generator set master switch in RUN position.	If switch is good, zero ohms continuity. Any resistance other than zero indicates defective switch.
	P1-2 (47) and P1-14 (N).	Ohmmeter on R x 1000 scale. Place generator set master switch in OFF/RESET position.	If switch is good, no reading or infinity. Any other reading indicates defective switch.
Remote switch light, if equipped	(+) and (-) terminals.	Ohmmeter on R x 1 scale.	If light is good, continuity. No continuity, replace light.
Hourmeter	(+) and (-) terminals.	Ohmmeter on R x 1 scale.	If hourmeter is good, continuity. No continuity, replace hourmeter.
Carburetor shutdown solenoid on gasoline-fueled sets only	Solenoid (+) lead and ground.	Ohmmeter on R x 1 scale. Disconnect solenoid leads when testing.	If solenoid is good, 4-5 ohms.
Choke heater	Choke terminals.	Ohmmeter on R x 100 scale.	If heater is good, continuity.
P1 wiring harness	P1-14 and ground.	Ohmmeter on R x 1 scale.	If P1 wiring harness good, zero ohms. Any other reading indicates a poor ground connection.
	P1-12 and P1-15 (1 and 2 stator leads).	Ohmmeter on R x 1 scale.	If P1 wiring harness good, continuity zero ohms..
P2 wiring harness	P1-12 and P1-15 (7 and 10 stator leads).	Ohmmeter on R x 1 scale.	If P2 wiring harness good, zero ohms. Any other reading indicates a poor ground connection.
Controller 10-amp fuse and wiring	P1-10 and battery positive (+) cable.	Ohmmeter on R x 100 scale.	If fuse and wiring are good, zero ohms. No continuity indicates open circuit and/or blown fuse.
Voltage regulator circuit 10-amp fuse	P4-5 and stator lead 55 at fuse holder.	Ohmmeter on R x 100 scale.	If fuse and wiring are good, zero ohms. No continuity indicates blown fuse or open wiring.
K20/K5 relay coil (starter relay)	K20/K5 S terminal and relay base (ground).	Ohmmeter on R x 1 scale.	If relay is good, 3-4 ohms. Low resistance indicates shorted K20 relay coil and/or wiring. High resistance indicates open K20/K5 relay coil and/or wiring.

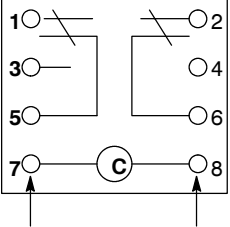

The diagram shows a top-down view of the relay controller with a label 'S Terminal' pointing to a specific terminal. Below it is a schematic diagram of the relay coil circuit, with a label 'S Terminal' pointing to the coil's connection point.

Figure 5-26 Engine/Generator Component Testing, Relay Controller (Sheet 2 of 4)

Component	Ohmmeter Connections	Procedure	Results
K21/K6 relay coil (cyclic crank relay and wiring). See Figure 4-1 for location. 	K21/K6 relay terminals 7 and 8.	Ohmmeter on R x 1 scale. Disconnect and remove relay from controller.	If relay and wiring are good, approximately 160 ohms. Low resistance indicates shorted relay coil. High resistance indicates open relay coil.
Low coolant level (LCL) switch*	P1-7 and ground (engine block).	Ohmmeter on R x 1000 scale. Low Oil Pressure (LOP) and High Engine Temperature (HET) switches disconnected.	If switch is good, 30-80 ohms with engine cold and LCL switch immersed in coolant. Any other reading, replace LCL switch.
High engine temperature (HET) switch*	P1-7 and ground (engine block).	Ohmmeter on R x 1000 scale. Low Oil Pressure (LOP) and Low Coolant Level (LCL) switches disconnected.	If switch is good, no resistance (infinity). Any other reading indicates defective switch and/or wiring.
Low oil pressure (LOP) switch*	P1-7 and ground (engine block).	Ohmmeter on R x 1000 scale. High Engine Temperature (HET) and Low Coolant Level (LCL) switches disconnected.	If switch is good, zero ohms (continuity). No reading indicates defective switch and/or wiring.

* See Relay Controller, Fault Shutdown Test Procedure in Section 5.

Figure 5-27 Engine/Generator Component Testing, Relay Controller (Sheet 3 of 4)

Controller Circuit Board

You can check some controller circuit board components without removing the component from the board. Make these checks prior to installing a new board and attempting startup. Section 3, General Troubleshooting, refers to most of the tests. Use a high-

quality multimeter and follow the manufacturer's instructions. To obtain accurate test readings, remove all circuit board connectors and conformal coating (transparent insulation) from component terminals. Use the chart in Figure 5-28 and the controller circuit board illustration (Figure 4-3).

Component	Ohmmeter Connections	Procedure	Results
K1, K2, K3, K4 relay coil 	K1 Coil Terminals (see relay schematic).	Ohmmeter on R x 10 scale.	If coil is good, approximately 400 ohms. Low resistance (continuity) indicates shorted coil. High resistance indicates open coil.

Figure 5-28 Engine/Generator Component Testing, Relay Controller (Sheet 4 of 4)

Generator Set Master Switch Electrical Contacts and Corresponding Actuator Position

Note: Controller switch electrical connections are reversed from position of switch.

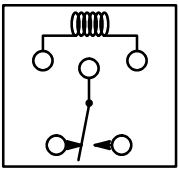
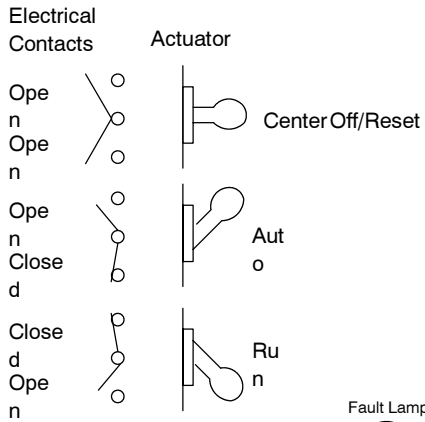

Legend

- AD Antidiesel Solenoid
- CH Choke Heater
- FS Fuel System
- HR Hourmeter
- IS Ignition System
- K20 Starter Relay
- M Starter Motor
- K21/K6 Cyclic Crank Relay
- SDR Overspeed Shutdown Relay
- TDR Time Delay Relay

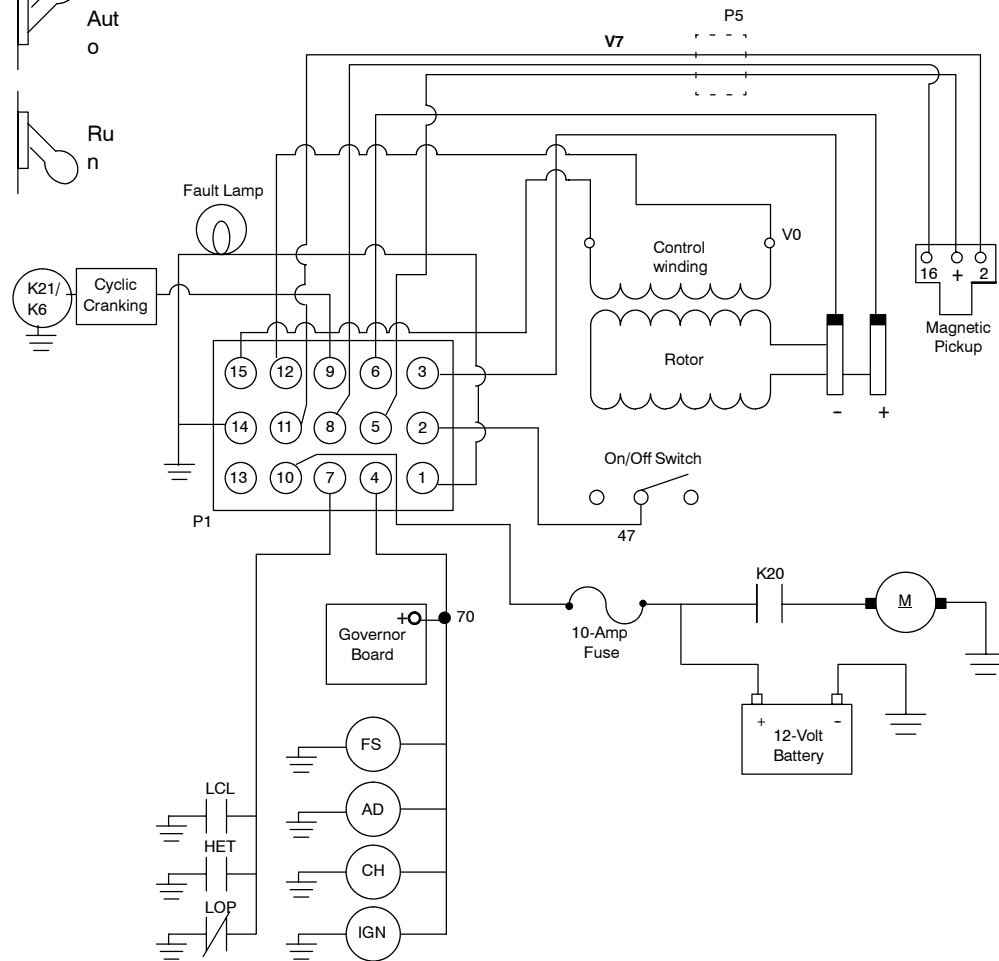
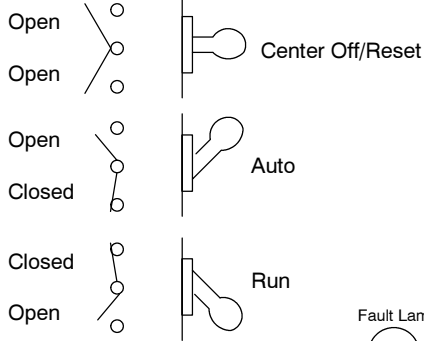

Figure 5-29 4-Lead Generator Wiring Harness Schematic (10/12RY/RFY Shown)

Generator Set Master Switch Electrical Contacts and Corresponding Actuator Position

Note: Controller switch electrical connections are reversed from position of switch.

Electrical Contacts Actuator



Legend

- AD Antidiesel Solenoid
- CH Choke Heater
- FS Fuel System
- HR Hourmeter
- IS Ignition System
- K20/K5 Starter Relay Contacts
- M Starter Motor
- SDR Overspeed Shutdown Relay
- TDR Time Delay Relay
- K21/K6 Cyclic Crank Relay

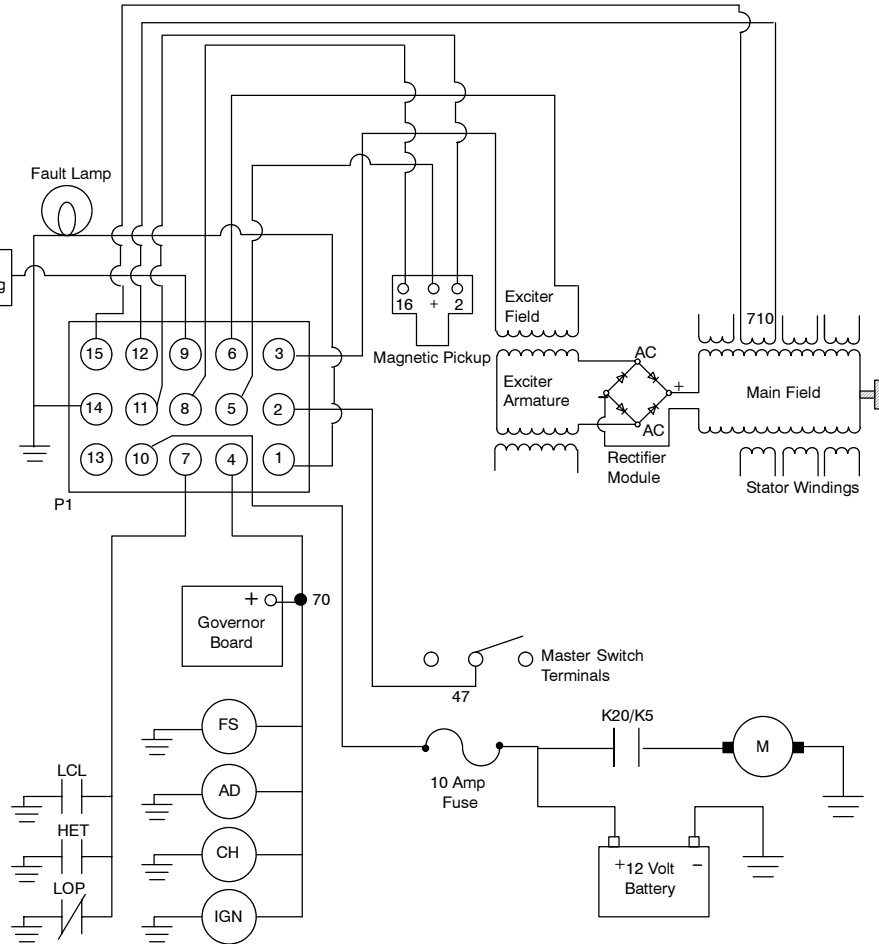

Figure 5-30 4-Lead Generator Wiring Harness Schematic (10/12RZ/RFZ Shown)

5.5.2 5-Light Microprocessor Controller

With the generator set battery connected, check the wiring harness and some engine/generator components. Place the generator set master switch or remote start/stop switch in the prescribed position and

check for voltage at each component using a voltmeter. These tests verify the switches function and the presence of voltage at each component. See Figure 5-31 through Figure 5-32 for testing engine/generator components on generator sets with 5-light microprocessor controllers.



Component	Voltmeter Connections	Procedure	Results
Hourmeter and wiring	Red test lead to hourmeter positive (+) terminal. Black test lead to hourmeter negative (-) terminal.	Voltmeter setting 12 volts DC or greater. Start generator set.	12-volt DC reading indicates wiring harness is okay. Hourmeter functions if good.
Stator 1-2 winding (control winding)	V0 and V7 terminals in controller.	Voltmeter setting 50 volts AC or greater. Start generator set and allow it to reach rated speed.	Reading of approximately 120 volts AC indicates stator 1-2 winding is good.
Stator 7-10 winding (1-4 winding, 600V) (control winding)	V7 and V0 terminals in controller.	Voltmeter setting 150 volts AC or greater. Start generator set and allow it to reach rated speed.	Reading of approximately 120 volts AC indicates stator 7-10 winding is good.
Choke heater, carburetor solenoid (gasoline units), fuel pump, fuel valve (LP units)	Red test lead to each component positive (+) terminal. Black test lead to engine block ground.	Place controller or remote switch to START position. Voltmeter setting 12 volts DC or greater.	12-volt DC reading indicates wiring harness is okay. To determine if fuel pump, fuel valve (LP), or vaporizer solenoid (LP) is good, proceed to next step. Also see engine components ohmmeter checks on the following pages.
Fuel pump (gasoline units only)	None	Disconnect fuel pump battery positive (+) lead and apply 12 volts DC. WARNING: See Safety Precautions before proceeding.	If pump is good, fuel pump operates.
Fuel valve (LP gas only)	None	Disconnect fuel valve battery positive (+) lead and apply 12 volts DC. WARNING: See Safety Precautions before proceeding.	If valve is good, fuel valve actuates; fuel valve makes audible click.
Governor actuator	None	Disconnect actuator harness and apply 12 volts DC to actuator.	If actuator is good, actuator thrusts. Actuator returns to relaxed position when DC is removed.
Water temperature gauge, if equipped	Red test lead to positive (+) side of gauge (wire 70). Black test lead to generator ground connection.	Start generator set to test voltage.	Battery should register voltage of approximately 12 volts DC. If no voltage registers, check controller circuit board and wiring. If voltage is present at gauge, stop set and check continuity of wiring between gauge and ground. Read resistance of sender during continuity check. See Water Temperature Sender in this section. If wiring tests okay, replace gauge.
Oil pressure gauge, if equipped	Red test lead to positive (+) side of gauge (wire 70). Black test lead to generator ground connection.	Start generator set to test voltage.	Battery should register voltage of approximately 12 volts DC. If no voltage registers, check controller circuit board and wiring. If voltage is present at gauge, stop set and check continuity of wiring between gauge and ground. Read resistance of sender during continuity check. See Oil Pressure Sender in this section. If wiring tests okay, replace gauge.
Voltmeter, if equipped	Red test lead to positive (+) side of gauge (wire 70). Black test lead to generator ground connection.	Start generator set.	Battery should register voltage of approximately 12 volts DC. If no voltage registers, check controller circuit board and wiring. If voltage is present, stop set and check continuity of wiring between meter and ground. If wiring tests okay, replace meter.

Figure 5-31 Engine/Generator Component Testing, 5-Light Microprocessor Controller (Sheet 1 of 3)

To further check generator set components, disconnect the battery and remove wiring harness plugs from the controller circuit board. Use an ohmmeter to check continuity and to isolate defective components. Use the following chart and the appropriate wiring diagram in the Wiring Diagram Manual.

Note: Before performing ohmmeter checks, disconnect generator set battery to prevent damage to the ohmmeter.

Short circuits. Hazardous voltage/current can cause severe injury or death. Short circuits can cause bodily injury and/or equipment damage. Do not contact electrical connections with tools or jewelry while making adjustments or repairs. Remove all jewelry before servicing the equipment.

 WARNING

<p>Hazardous voltage. Backfed to the utility system can cause property damage, severe injury, or death.</p> <p>If the generator set is used for standby power, install an automatic transfer switch to prevent inadvertent interconnection of standby and normal sources of supply.</p>

Component	Ohmmeter Connections	Procedure	Results
Remote switch light, if equipped	(+) and (-) terminals.	Place ohmmeter on R x 1 scale.	If light is good, continuity. No continuity, replace light.
Hourmeter	(+) and (-) terminals.	Place ohmmeter on R x 1 scale.	If hourmeter is good, continuity. No continuity, replace hourmeter.
Carburetor shutdown solenoid (gasoline- fueled sets only)	Solenoid (+) lead and ground.	Place ohmmeter on R x 1 scale.	If solenoid is good, 4-5 ohms. Disconnect solenoid leads when testing.
Choke heater	Choke terminals	Place ohmmeter on R x 100 scale.	If heater is good, continuity.
P1 wiring harness	P1-5 and ground.	Place ohmmeter on R x 1 scale.	If wiring harness is good, zero ohms. Any other reading indicates a poor ground connection.
P2 wiring harness	P2-6 and ground.		If wiring harness is good, zero ohms. Any other reading indicates a poor ground connection.
Voltage regulator circuit 10-amp fuse	P11-5 and stator lead 55 at fuse holder.	Place ohmmeter on R x 100 scale.	If fuse is good, zero ohms. No continuity indicates blown fuse or open wiring.
K1 relay coil (starter relay)	K1 S terminal and relay base (ground).	Place ohmmeter on R x 1 scale.	If coil is good, 3-4 ohms. Low resistance indicates shorted K20 relay coil and/or wiring. High resistance indicates open K20 relay coil and/or wiring.
			
K20/K5 relay coil (field flashing relay). See Figure 4-1 for location.	K20/K5 relay terminals 7 and 8.	Place ohmmeter on R x 1 scale. Disconnect and remove relay from controller.	If coil is good, approximately 160 ohms. Low resistance indicates shorted relay coil. High resistance indicates open relay coil.
			

Figure 5-32 Engine/Generator Component Testing, 5-Light Microprocessor Controller (Sheet 2 of 3)

Component	Ohmmeter Connections	Procedure	Results
Low coolant level (LCL) switch*	P1-14 and ground (engine block).	Place ohmmeter on R x 1000 scale.	If switch is good, 30-80 ohms with engine cold and LCL switch immersed in coolant. Any other reading, replace LCL switch.
High engine temperature (HET) switch*	P1-21 and ground (engine block).	Place ohmmeter on R x 1000 scale.	If switch is good, no resistance (infinity). Any other reading indicates defective switch and/or wiring.
Low oil pressure (LOP) switch*	P1-22 and ground (engine block).	Place ohmmeter on R x 1000 scale.	If switch is good, zero ohms (continuity). No reading indicates defective switch and/or wiring.

* See 5-Light Controller, Fault Shutdown Test Procedure in Section 5.

Figure 5-33 Engine/Generator Component Testing, 5-Light Microprocessor Controller (Sheet 3 of 3)

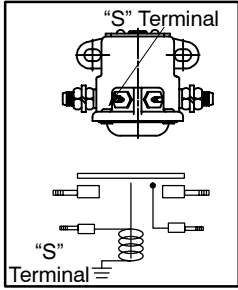
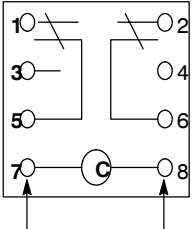
5.6 Fault Shutdown Test Procedure

Verify operation of the generator overspeed, overcrank, low coolant level, low oil pressure, and high engine temperature shutdowns by performing the following tests with the generator set running. If these tests are inconclusive, test individual shutdown circuit components (circuit board, wiring harness, switch, etc.) as described earlier in this section.

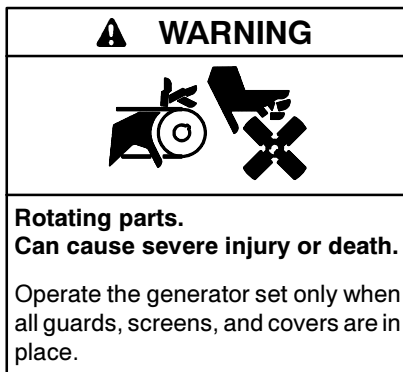

Exposed moving parts can cause severe injury or death.

Keep hands, feet, hair, and clothing away from belts and pulleys when unit is running. Replace guards, covers, and screens before operating generator set.

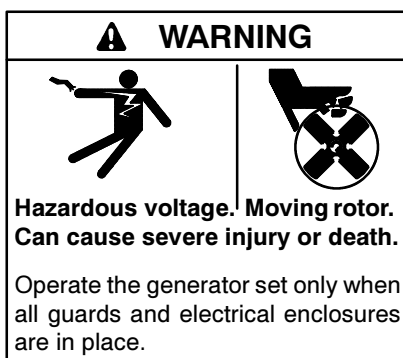

Grounding electrical equipment. Hazardous voltage can cause severe injury or death. Electrocutation is possible whenever electricity is present. Open the main circuit breakers of all power sources before servicing the equipment. Configure the installation to electrically ground the generator set, transfer switch, and related equipment and electrical circuits to comply with applicable codes and standards. Never contact electrical leads or appliances when standing in water or on wet ground because these conditions increase the risk of electrocution.

Short circuits. Hazardous voltage/current can cause severe injury or death. Short circuits can cause bodily injury and/or equipment damage. Do not contact electrical connections with tools or jewelry while making adjustments or repairs. Remove all jewelry before servicing the equipment.

5.6.1 Overspeed

Start generator set and manually adjust engine speed (by moving carburetor throttle linkage) to exceed rated engine rpm (1800 rpm). Generator shuts down and fault lamp lights if engine speed exceeds 70 Hz.

5.6.2 Low Oil Pressure (LOP) Shutdown

Connect a jumper wire from the LOP switch (see Section 3 for location) to the generator set ground. Start generator set. After approximately 5-8 seconds the generator set shuts down and the fault lamp lights.

5.6.3 Low Coolant Level (LCL) Shutdown

Connect a jumper wire from LCL sensor to generator set ground. Start generator set. After approximately 5-8 seconds, the generator set shuts down and the fault lamp lights.

5.6.4 High Engine Temperature (HET) Shutdown

Connect a jumper from the HET switch (lead 34) to the generator set ground. Start generator set. After approximately 5–8 seconds, the generator set shuts down and the fault lamp lights.

5.6.5 Overcrank Shutdown

Disconnect fuel supply to prevent flooding and remove coil wire from ignition module. Move generator set master switch to the RUN position. Generator set cranks for 8 seconds then rests for 3 seconds. After the third crank/rest cycle, the generator set shuts down and the fault lamp lights.

5.7 Exciter Field, 10-18RZ/RFZ

DC from the battery magnetizes the exciter field. When the exciter armature rotates within the magnetized exciter field windings, an electrical current develops within the exciter armature. Test the exciter field according to the following procedure.

1. Disconnect generator starting battery, negative (-) lead first.
2. Disconnect power to battery charger, if equipped.
3. Disconnect exciter leads F1 and F2 at TB2 terminal strip.
4. Check exciter field resistance by connecting an ohmmeter across exciter field F1 and F2. The resistance reading for a cold exciter field should be 4.5 ohms \pm 10% for 10/12RZ and 5.0 ohms \pm 5% for 18RZ generators. A low reading indicates an internal short and a high reading indicates an open winding. Repair or replace exciter field if ohmmeter readings indicate a defective exciter field. If resistance test proves inconclusive, perform a megohmmeter test on exciter field as described in the next step.

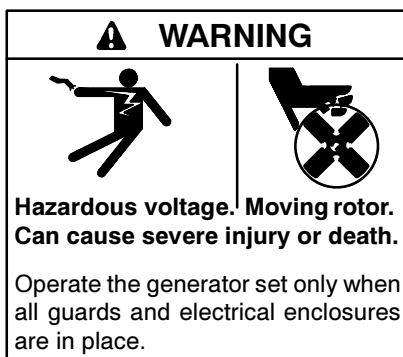

High voltage test. Hazardous voltage can cause severe injury or death. Follow the instructions of the test equipment manufacturer when performing high-voltage tests on the rotor or stator. An improper test procedure can damage equipment or lead to generator set failure.

Short circuits. Hazardous voltage/current can cause severe injury or death. Short circuits can cause bodily injury and/or equipment damage. Do not contact electrical connections with tools or jewelry while making adjustments or repairs. Remove all jewelry before servicing the equipment.

5. Check exciter field for a grounded condition. Use a megohmmeter to apply 500 volts DC to F1 or F2 lead and exciter field frame. Follow the instructions of the megohmmeter manufacturer when performing this test. A reading of approximately 500 kOhms (1/2 megohm) and higher indicates the field winding is good. A reading of less than approximately 500 kOhms indicates deterioration of winding insulation and possible current flow to ground. Repair or replace the exciter field.

5.8 Exciter Armature, 10-18RZ/RFZ

The exciter armature supplies excitation current to the generator main field through the rectifier module. Test the exciter armature as described in the following steps. Disassemble the generator set prior to performing this test.

1. With generator disassembled, disconnect armature leads from rectifier module AC terminals.
2. With an ohmmeter on the R x 1 scale, check resistance across exciter armature leads. See Figure 5-34. The armature resistance should be 0.6-0.8 ohms (continuity). No continuity indicates an open armature winding. If the resistance test proves inconclusive, perform a megohmmeter test on the exciter armature as described in the next step.

Note: Most ohmmeters will not provide accurate readings when measuring less than 1 ohm. Consider the exciter armature good if resistance reading (continuity) is low and there is no evidence of a shorted winding (heat discoloration).

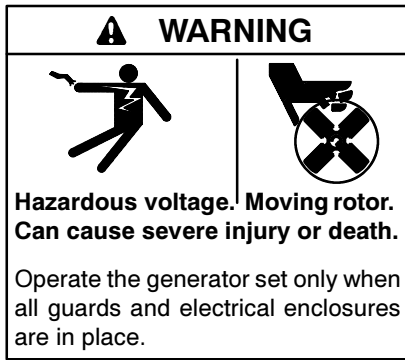

High voltage test. Hazardous voltage can cause severe injury or death. Follow the instructions of the test equipment manufacturer when performing high-voltage tests on the rotor or stator. An improper test procedure can damage equipment or lead to generator set failure.

Short circuits. Hazardous voltage/current can cause severe injury or death. Short circuits can cause bodily injury and/or equipment damage. Do not contact electrical connections with tools or jewelry while making adjustments or repairs. Remove all jewelry before servicing the equipment.

3. Check exciter armature winding for a grounded condition. Use a megohmmeter to apply 500 volts DC to either armature lead and armature frame. Follow the instructions of the megohmmeter manufacturer when performing this test. See Figure 5-35. A reading of approximately 500K ohms (1/2 megohm) and higher indicates the exciter armature is good. A reading of less than approximately 500 kOhms indicates deterioration of winding insulation and possible current flow to ground. Repair or replace the exciter armature.

5.9 Rectifier Module, 10-18RZ/RFZ

The rectifier module located between exciter armature and main field converts the AC from the exciter armature to DC which magnetizes the generator main field. Test the rectifier module as described in the following steps.

1. Disconnect exciter armature and main field leads from rectifier module.
2. Use an ohmmeter on the R x 100 scale to check resistance between rectifier diodes as shown in Figure 5-36. To test CR3, for example, place ohmmeter leads on rectifier terminals B3 and B4. The ohmmeter should show a low resistance in one direction and, upon reversing ohmmeter leads, a high resistance in the other direction. Replace the rectifier module if any of the diodes tests different than described.

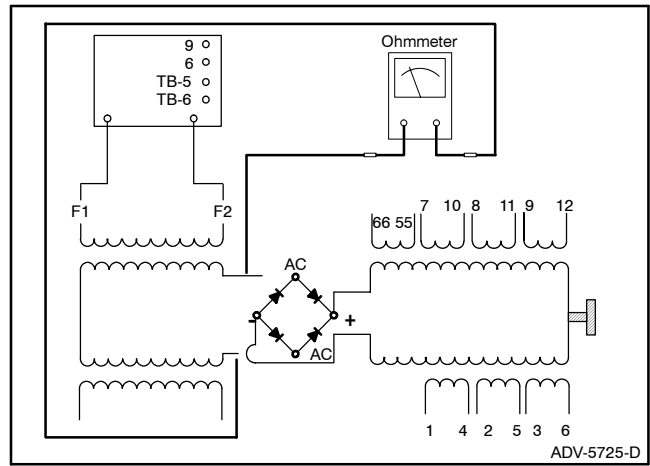

Figure 5-34 Exciter Armature Ohmmeter Test (10/12RZ Shown)

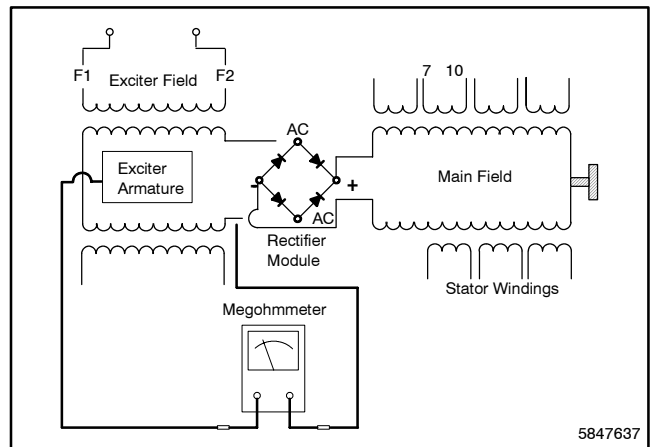

Figure 5-35 Megohmmeter Connections on Exciter Armature (10/12RZ Shown)

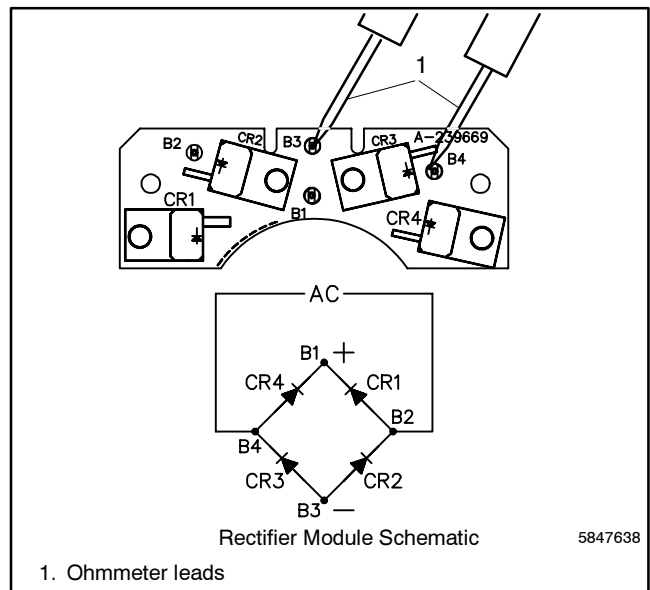



Figure 5-36 Testing Rectifier Module

5.10 Rotor (Main Field)

5.10.1 10-18RY/RFY

The 4-pole rotor creates the magnetic field needed to raise alternating current in the stator windings. Prior to testing, inspect the rotor for visible damage to pole shoes, insulation, exposed coil windings, and slip ring surfaces. Check bearing for noise when rotated. Also check bearing for wear and heat discoloration.

Slip rings acquire a glossy brown finish in normal operation. Do not attempt to maintain a bright, newly machined appearance. Ordinary cleaning with a dry, lint-free cloth is usually sufficient. Use very fine sandpaper (#00) to remove roughness. Use light pressure on the sandpaper. Do not use emery or carborundum paper or cloth. Clean out all carbon dust from the generator. If the rings are black or pitted, remove the rotor and remove some of the surface material using a lathe.

⚠ WARNING

<p>Hazardous voltage. Backfeed to the utility system can cause property damage, severe injury, or death.</p> <p>If the generator set is used for standby power, install an automatic transfer switch to prevent inadvertent interconnection of standby and normal sources of supply.</p>

High voltage test. Hazardous voltage can cause severe injury or death. Follow the instructions of the test equipment manufacturer when performing high-voltage tests on the rotor or stator. An improper test procedure can damage equipment or lead to generator set failure.

1. Disconnect generator set engine starting battery, negative (-) lead first. Disconnect power to battery charger, if equipped.
2. Check the rotor for continuity and resistance. Measure the rotor resistance (ohms) between the two slip rings (Figure 5-37). Raise the brushes from the slip rings while performing ohmmeter tests. See Figure 5-38 for typical readings. If the resistance test proves inconclusive, perform megohmmeter test on rotor as described in next step.

Note: Because ohmmeters vary in their accuracy, use Figure 5-38 as a reference for approximate readings. Take readings at room temperature.

3. Perform a megohmmeter test to determine whether the rotor is shorted to ground. Raise brushes away from slip rings and secure in this position by inserting a retaining wire in the brush holder hole. Use a megohmmeter to apply 500 volts DC to either rotor slip ring and rotor poles or shaft. See Figure 5-39. Follow the instructions of the megohmmeter manufacturer when performing this test. A reading of approximately 500 kOhms (1/2 megohm) and higher indicates the rotor is good. A reading of less than approximately 500 kOhms indicates deterioration of winding insulation and possible current flow to ground. Repair or replace the rotor. Following test, remove retainer wire from brush holder and verify that brushes are correctly positioned on slip rings.

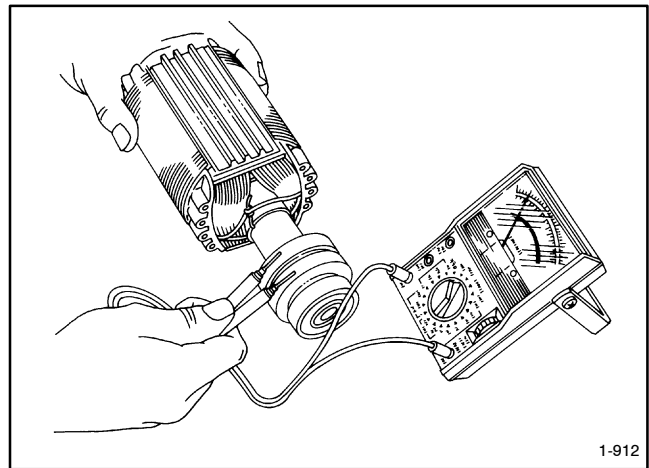

Figure 5-37 Rotor Resistance Check (10/12RY Shown)

Model	Resistance: Ohms
10RY/RFY	3.9±10%
12RY/RFY	2.8±10%
18RY/RFY	2.8±10%

Figure 5-38 Rotor Resistance Readings (approximate)

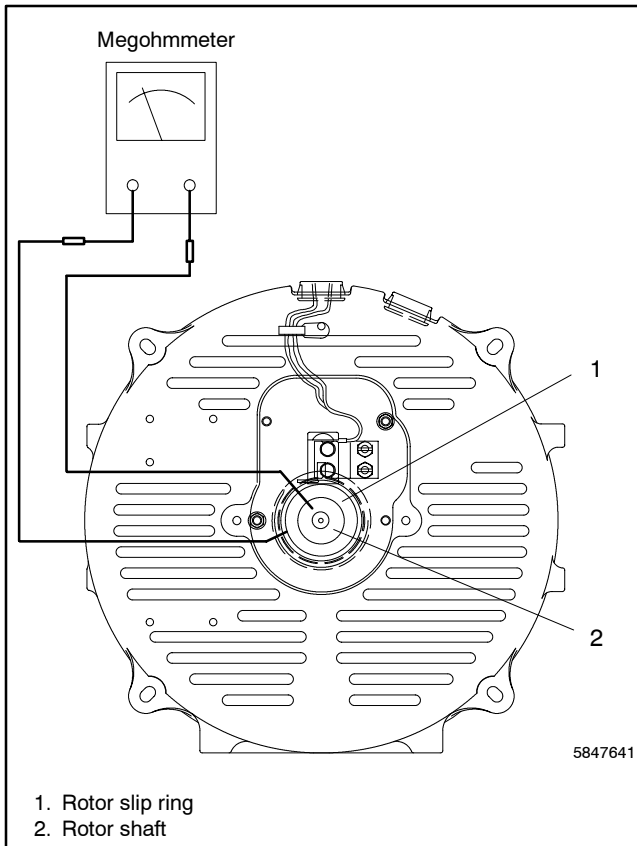

Figure 5-39 Performing Megohmmeter Test on Rotor (10/12RY Shown)

5.10.2 10-18RZ/RFZ

The generator main field (magnetized by DC from the rectifier module) rotating within the stator windings induces AC in the stator windings. Test generator main field as described in the following steps. Disassemble the generator prior to performing this test.

1. With the generator disassembled, disconnect generator main field windings from rectifier module B2 and B4 terminals (F+ and F-).
2. Check main field resistance by connecting an ohmmeter across main field F+ and F- leads. See Figure 5-40. The resistance reading for a cold main field should be approximately 6.0-7.4 ohms for 10RZ and 7.0-8.6 ohms for 12/18RZ generators. A low reading indicates an internal short and a high

reading indicates an open winding. Repair or replace main field if ohmmeter readings indicate main field is defective. If the resistance test proves inconclusive, perform a megohmmeter test on the main field as described in the next step.

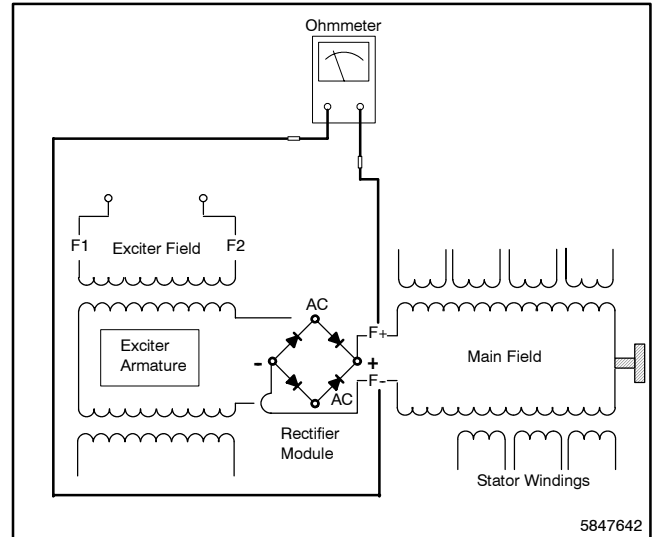
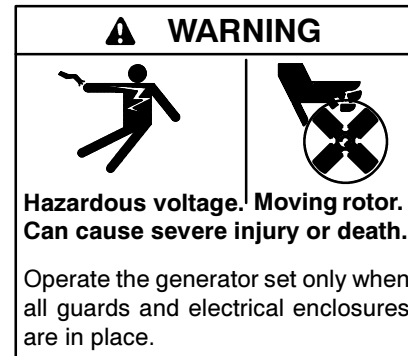

Figure 5-40 Ohmmeter Connections on Main Field (10/12RZ Shown)



High voltage test. Hazardous voltage can cause severe injury or death. Follow the instructions of the test equipment manufacturer when performing high-voltage tests on the rotor or stator. An improper test procedure can damage equipment or lead to generator set failure.

Short circuits. Hazardous voltage/current can cause severe injury or death. Short circuits can cause bodily injury and/or equipment damage. Do not contact electrical connections with tools or jewelry while making adjustments or repairs. Remove all jewelry before servicing the equipment.



3. Check main field for a grounded condition by using a megohmmeter. Apply 500 volts DC to either field lead and main field frame. Follow the instructions of the megohmmeter manufacturer when performing this test. See Figure 5-41. A reading of approximately 500 kOhms (1/2 megohm) and higher indicates the main field is good. A reading of less than approximately 500 kOhms indicates deterioration of winding insulation and possible current flow to ground. Repair or replace the main field.

5.11 Stator

5.11.1 10-18RY/RFY

The stator consists of a series of coils of wire laid in a laminated steel frame. The stator leads supply voltage to the AC load and exciter regulator. Prior to testing, inspect the stator for heat discoloration and visible damage to housing lead wires, exposed coil windings, and exposed and varnished areas of frame laminations. Be sure the stator is securely riveted in the stator housing.

Note: Disconnect all stator leads prior to performing all stator tests.

 WARNING

<p>Hazardous voltage. Backfeed to the utility system can cause property damage, severe injury, or death.</p> <p>If the generator set is used for standby power, install an automatic transfer switch to prevent inadvertent interconnection of standby and normal sources of supply.</p>

High voltage test. Hazardous voltage can cause severe injury or death. Follow the instructions of the test equipment manufacturer when performing high-voltage tests on the rotor or stator. An improper test procedure can damage equipment or lead to generator set failure.

1. Disconnect generator set engine starting battery, negative (-) lead first. Disconnect power to battery charger, if equipped.
2. To check stator continuity, set ohmmeter on R x 1 scale. Contact the red and black meter leads; adjust ohmmeter to zero ohms. Check stator

continuity by connecting meter leads to stator leads as shown in Figure 5-42.

Note: Leads 1, 2, 3, and 4 are the generator output leads. Leads 33, 44, and 55 are the voltage regulator sensing and supply leads. Refer to the schematic in Figure 5-44 when performing the following tests.

3. Contact ohmmeter leads and readjust ohmmeter to zero ohms. Check cold resistance of stator windings by connecting meter leads to stator leads 1 and 2, 3 and 4, 33 and 44, and 55 and 33. Figure 5-45 lists typical stator winding resistance readings. If the resistance test proves inconclusive, perform a megohmmeter test on stator as described in next step.

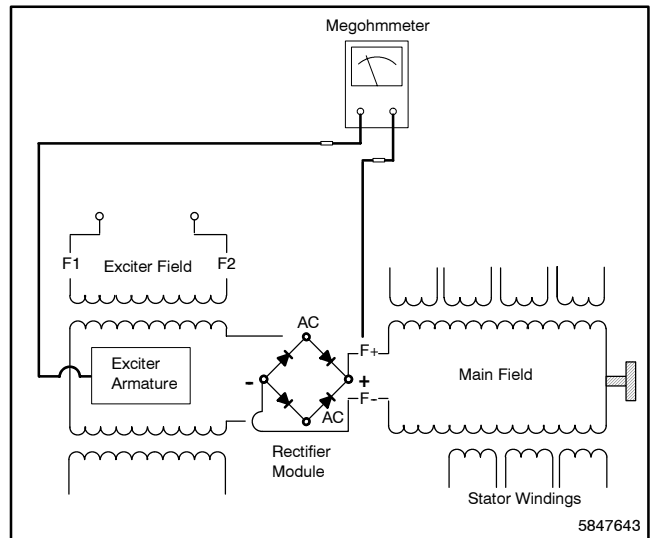

Figure 5-41 Megohmmeter Connections on Main Field (10/12RZ Shown)

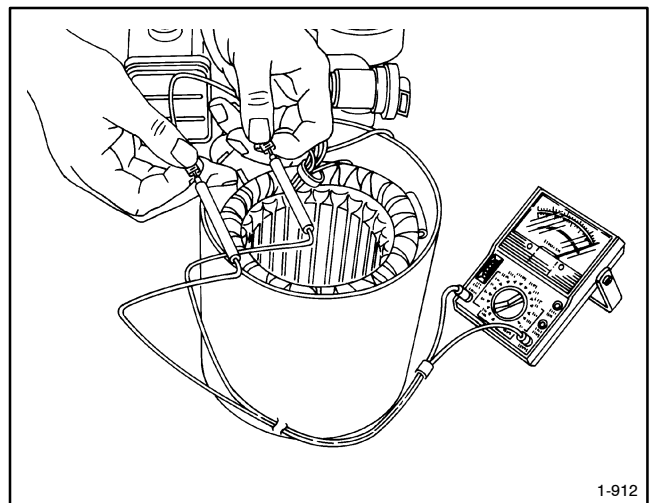

Figure 5-42 Testing Stator Windings (10/12RY Shown)

Between leads	Continuity
1 and 2	Yes
3 and 4	Yes
33 and 44	Yes
3 and 44	Yes
55 and 3	Yes
55 and 33	Yes
1 and 3, 4, 33, 44, 55	No
Any stator lead and ground	No

Figure 5-43 Stator Continuity

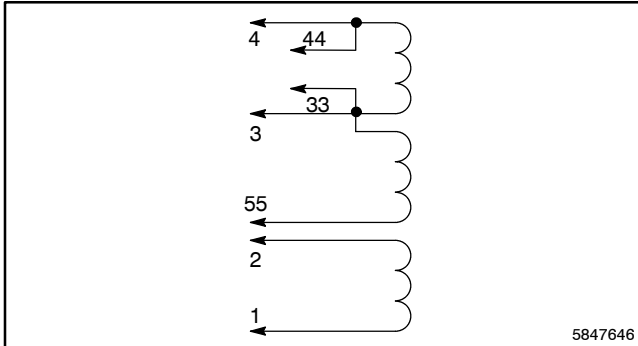

Figure 5-44 Generator Stator Leads

Note: Because ohmmeters vary in their accuracy, use Figure 5-45 as a reference for approximate readings. Take ohmmeter readings at room temperature.

Note: Most ohmmeters will not provide accurate readings when measuring less than 1 ohm. Consider the stator good if resistance reading (continuity) is low and there is no evidence of shorted windings (heat discoloration).

⚠ WARNING

Hazardous voltage. Backfeed to the utility system can cause property damage, severe injury, or death.

If the generator set is used for standby power, install an automatic transfer switch to prevent inadvertent interconnection of standby and normal sources of supply.

High voltage test. Hazardous voltage can cause severe injury or death. Follow the instructions of the test equipment manufacturer when performing high-voltage tests on the rotor or stator. An improper test procedure can damage equipment or lead to generator set failure.

4. Perform a megohmmeter test to determine whether the stator is shorted to ground. Use a megohmmeter to apply 500 volts DC to any stator lead and stator frame. Follow the instructions of the megohmmeter manufacturer when performing this test. Repeat test on other stator leads until each coil is tested. A reading of approximately 500 kOhms (1/2 megohm) and higher indicates the stator is good. A reading of less than approximately 500 kOhms indicates deterioration of winding insulation and possible current flow to ground. Repair or replace the stator.

Stator Leads	Resistance (Ohms) $\pm 10\%$	
	10/12RY	18RY
1-2, 3-4	0.06	0.05
33-44	0.06	0.05
55-33	1.26	1.10

Figure 5-45 Stator Winding Resistance

5.11.2 10-18RZ/RFZ

The stator produces electrical output (AC) as the magnetized main field rotates within the stator windings. Test the condition of the stator according to the following procedure.

1. Disconnect generator starting battery (negative (-) lead first) and power to battery charger, if equipped.
2. Check the generator output lead connections (see wiring diagrams in Wiring Diagram Manual).
3. Check condition of V0, V7, V8, and V9 at stator, terminal strip TB2 (relay controller) or TB3 (5-light controller), and at voltage regulator.
4. Use an ohmmeter to check continuity of V7, V8, and V9 leads between stator and voltage regulator. No continuity (high resistance) indicates an open lead. Repair any open leads.
5. Inspect stator for evidence of shorted windings (heat discoloration). If the stator shows signs of heat discoloration, test stator windings as described in the following steps before replacing stator.

6. Disconnect all stator leads to isolate windings. To check stator continuity, set ohmmeter on R x 1 scale. Contact the red and black ohmmeter leads; adjust ohmmeter to zero ohms. Check stator continuity by connecting meter leads to stator leads as shown in Figure 5-46. Perform stator tests on all stator windings.

7. Contact ohmmeter leads and readjust ohmmeter to zero ohms. Check cold resistance of stator windings by connecting meter leads to stator leads 1-4, 2-5, 3-6, etc. Figure 5-47 shows typical stator winding resistances. If the stator resistance test proves inconclusive, perform a megohmmeter test on stator as described in the next step.

Note: Most ohmmeters will not provide accurate readings when measuring less than 1 ohm. Consider the stator good if resistance reading (continuity) is low and there is no evidence of shorted windings (heat discoloration).

Between Leads	Continuity
1 and 2	yes
3 and 4	yes
33 and 44	yes
3 and 44	yes
55 and 3	yes
55 and 33	no
1 and 3, 4, 33, 44, 55	no
Any stator lead and ground	no

Figure 5-46 Stator Continuity

Stator Leads	Resistance (Ohms) ±10% 10/12RZ	Resistance (Ohms) ±10% 18RZ
1-4, 2-5, 3-6, etc.	0.19	0.04
55-66	1.40	1.30

Figure 5-47 Stator Winding Resistance

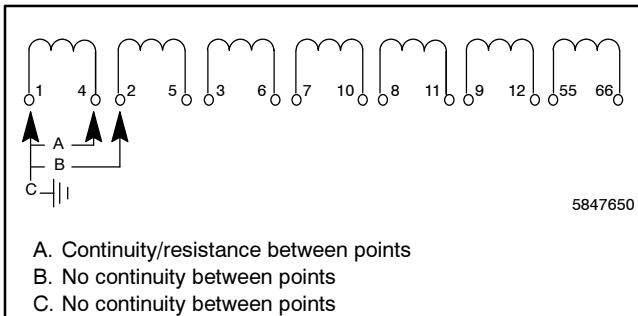
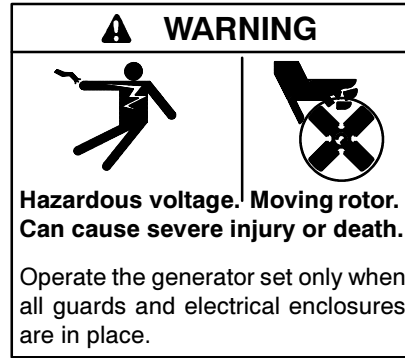

Figure 5-48 Stator Winding Test



High voltage test. Hazardous voltage can cause severe injury or death. Follow the instructions of the test equipment manufacturer when performing high-voltage tests on the rotor or stator. An improper test procedure can damage equipment or lead to generator set failure.

Short circuits. Hazardous voltage/current can cause severe injury or death. Short circuits can cause bodily injury and/or equipment damage. Do not contact electrical connections with tools or jewelry while making adjustments or repairs. Remove all jewelry before servicing the equipment.

8. Check stator for a grounded condition using a megohmmeter. Apply 500 volts DC to any stator lead from each winding and stator frame. Follow the instructions of the megohmmeter manufacturer when performing this test. Repeat test on other leads until all stator windings have been tested. A reading of approximately 500 kOhms (1/2 megohm) and higher indicates the stator is good. A reading of less than approximately 500 kOhms indicates deterioration of winding insulation and possible current flow to ground. Repair or replace the stator.

5.12 Brushes, 10-18RY/RFY

The brushes transfer current from the voltage regulator to the slip rings. The brushes carry a very low current, approximately 2 amps. Excessive arcing at the brushes could damage the voltage regulator. Arcing could be caused by weak springs, damaged slip rings, sticking brushes, loose brush holder, and/or poor brush contact.

The brushes must be free to move within the holder and be held in contact by the springs. When correctly positioned, spring pressure on the brush surface causes the brush to wear evenly. The entire brush must ride on the ring to avoid arcing, which can cause burned rings or failure of the voltage regulator. Figure 5-49 shows the correct positioning of the brushes. Add or remove shims as necessary to center brushes on slip rings.

Replace brushes if they show uneven wear or are worn to half their original length.

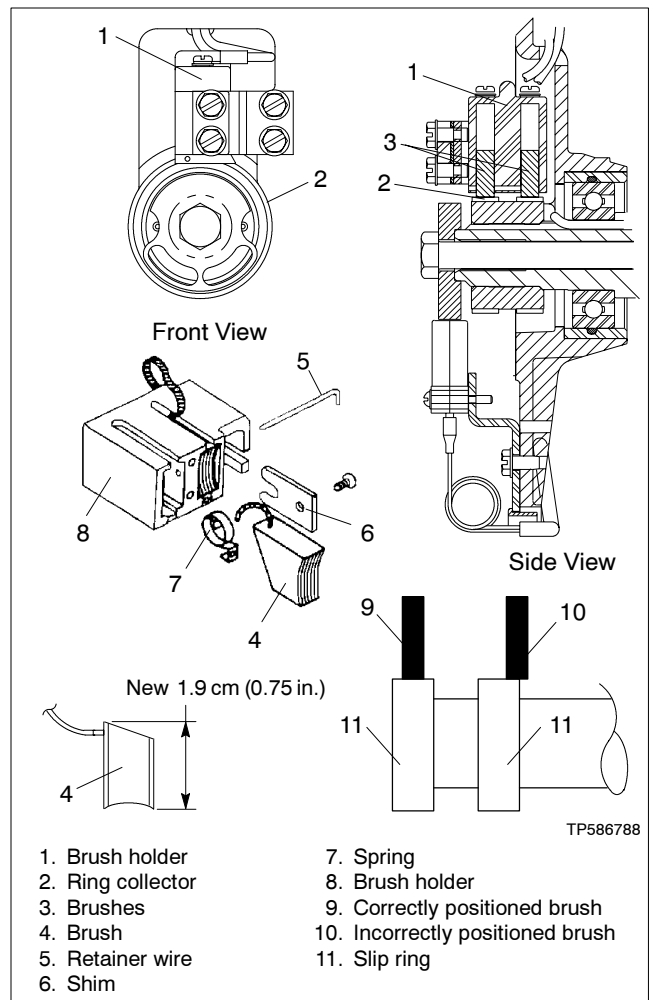

Figure 5-49 Brushes

5.13 Magnetic Pickup, 10-18RY/RFY

The magnetic pickup monitors engine speed (frequency) for controller operation. Location of the magnetic pickup is shown in Figure 5-50. Follow the procedure outlined below to determine if the magnetic pickup is emitting a signal. Additional magnetic pickup test information for models equipped with 5-light controllers is included in Section 5.

1. With generator set master switch in OFF or OFF/RESET position, connect a DC voltmeter between positive (+) lead (wire 24) at magnetic pickup and ground (wire 2). Voltmeter should read approximately 9.5 volts DC.
2. With generator set running, connect DC voltmeter negative (-) probe to 0 terminal (wire 16, white) on magnetic pickup. Place voltmeter positive (+) probe on positive (+) terminal (wire 24, red). Voltmeter should indicate approximately 7 volts DC.

If magnetic pickup is emitting a signal, check continuity of magnetic pickup leads (wires 2, 16, and 24). If the magnetic pickup is not emitting a signal, test the magnetic pickup through the following procedure.

Test Procedure

1. Remove magnetic pickup from generator adapter. Connect magnetic pickup, voltmeter, and DC voltage source as shown in Figure 5-51.
2. Touch sensing surface with a flat piece of iron or steel. Contact surface area of iron or steel piece should be at least 4.1 cm (1/4 cu. in.).
3. Voltmeter test reading should equal source voltage.
4. Remove iron or steel from sensing surface; voltmeter should indicate no voltage.

5. Reinstall magnetic pickup in generator adapter using **all** original hardware. When correctly installed, air gap between magnetic pickup and flywheel should be 0.5–1.27 mm (0.020–0.050 in.).

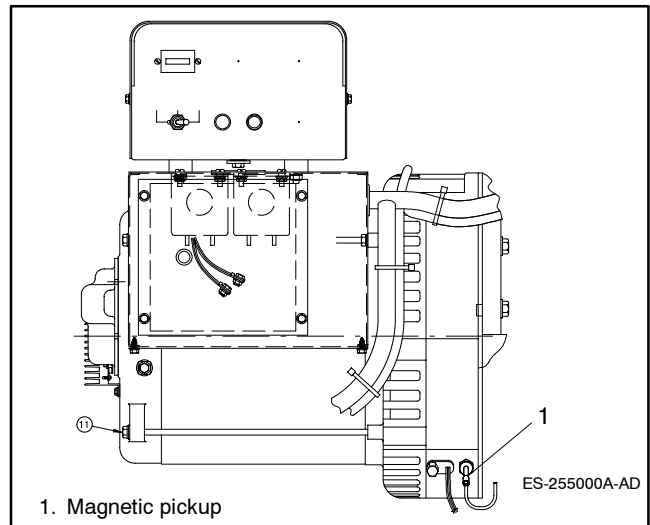

Figure 5-50 Generator Magnetic Pickup

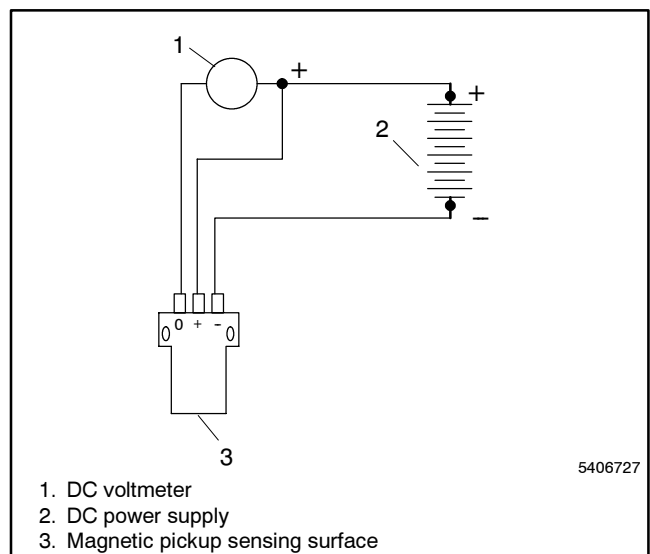

Figure 5-51 Magnetic Pickup Test

5.14 Water Temperature and Oil Pressure Senders, if Equipped

Some generators may be equipped with water temperature and oil pressure senders to activate controller-mounted meters. To test the water temperature sender, connect one ohmmeter lead to the sender terminal and the other ohmmeter lead to ground. See Figure 5-52 for sender location and Figure 5-53 below for sender resistance at different water temperatures. Start the generator set and check the sender resistance. As water temperature increases, a corresponding change in sender resistance occurs. Replace the sender if resistance readings vary greatly from those shown. Generally, a sender can be presumed good if the sender resistance value changes with temperature. A defective sender tests either open (no ohmmeter reading) or shorted (continuity). Replace the sender if resistance readings vary greatly from those shown. Generally, a sender can be presumed good if the sender resistance value changes with temperature. A defective sender tests either open (no ohmmeter reading) or shorted (continuity).

To test the oil pressure sender, connect one ohmmeter lead to the sender terminal and the other ohmmeter lead to ground. See Figure 5-54 and Section 3, Scheduled Maintenance for sender location and Figure 5-55 below for resistance of the oil pressure sender at different pressure levels. Start the generator set and check the sender resistance. As oil pressure increases, a corresponding change in sender resistance occurs. Replace the sender if resistance readings vary greatly from those shown. Generally, a sender can be presumed good if the sender resistance value changes with pressure. A defective sender tests either open (no ohmmeter reading) or shorted (continuity).

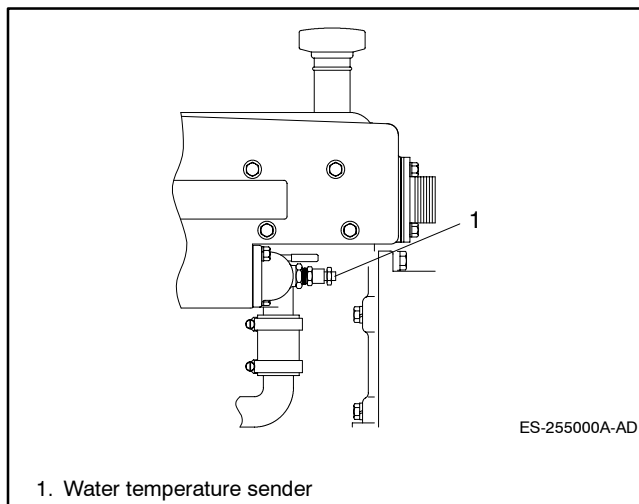

Figure 5-52 Water Temperature Sender Location

Temperature	Resistance: Ohms $\pm 10\%$
38°C (100°F)	450
71°C (160°F)	130
104°C (220°F)	47

Figure 5-53 Water Temperature Sender Resistance

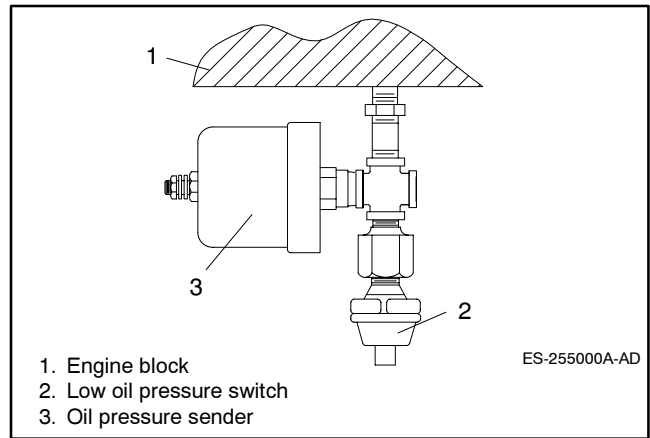

Figure 5-54 Oil Pressure Sender Location

Oil Pressure	Resistance: Ohms
0 kPa/psi	227-257
172 kPa (25 psi)	138-162
345 kPa (50 psi)	92-114
517 kPa (75 psi)	50-80
690 kPa (100 psi)	21-50

Figure 5-55 Oil Pressure Sender Resistance

5.15 Electronic Governor

5.15.1 Introduction

This service manual describes several governor configurations utilized for the models in this service manual. Determine which procedure to use by identifying the type of governor system on the generator set. See Figure 5-56.

Governor Style	Governor Manufacturer
AC Sensing	Barber Colman
Magnetic Pickup	Barber Colman
Magnetic Pickup	Kohler

Figure 5-56 Governor Identification

5.15.2 Electronic Governor (AC Sensing)

The isochronous electronic governor monitors generator output to maintain engine speed at 1500 rpm for 50 Hz units or 1800 rpm for 60 Hz units. When generator output frequency increases or decreases, a sensor on the stator winding sends a signal to the governor control circuit board located in generator junction box. The circuit board interprets the signal from the sensor to control current input to the throttle actuator. The throttle actuator adjusts the engine throttle position to maintain engine speed. Usually the governor requires no maintenance or adjustment. However, if any component of the governor is removed

or tampered with, readjust the governor according to the following procedure.

Governor Test Procedure, 10/12 kW

If the generator will not pick up or maintain rated speed under load, check the following items:

- Fuel pressure on natural gas-fueled units should be at least 7 in. water column. Maintain fuel pressure at 5 in. water column at carburetor side of regulator. Readjust pressure regulator, if necessary, to obtain specified fuel pressure. See Fuel System.
- Battery voltage to the governor circuit board (+) and (-) terminals should be at least 11 volts DC. If governor board DC voltage is low or absent, check related wiring and connections and controller main circuit board operation. See Controller Circuit Board in Section 7 or Section 8.
- AC voltage at governor board Gen Volt. terminal should be at least 90 volts AC. If AC voltage is low or absent, check related wiring and connections between AC terminal block and governor circuit board. If wiring/connections appear okay, check generator output as described in Section 4, General Troubleshooting.
- On gasoline-fueled generators, be sure that carburetor choke is set correctly. See Section 3, Gasoline Choke Adjustment.

Governor Adjustment Procedure, 10/12 kW

Note: The -2.5 Hz/FREQ terminals on some of the governor circuit board are used to change engine speed during voltage regulator adjustment. Do not tamper with these terminals during governor adjustment.

1. Verify that swivel on actuator arm is fully threaded on actuator shaft and secured with locknut.
2. Adjust throttle rod assembly using following procedure:
 - a. Back out the idle adjust screw.
 - b. Test the throttle actuator position. Hold the linkage in the full, open position. Release the linkage forcing the spring to snap it back to the idle position. Listen for a click as the linkage snaps back to the idle position.

- c. Adjust governor linkage length by turning the threaded rod 1/2 turn at a time and listen for a dull click. The dull click indicates the throttle plate is striking the carburetor bore.
 - d. Lengthen governor linkage by turning the threaded rod 1/2 turn at a time and listen for a sharp click. The sharp click indicates the actuator is stopping the throttle plate just short of striking the carburetor bore. Set the linkage at this point.
 - e. For maximum response, the actuator threaded rod must be about 90 degrees (perpendicular) to the throttle lever arm at no load rated rpm.
3. When throttle rod is set to correct length, tighten ball joint locknuts to maintain rod length. When correctly adjusted, the throttle linkage operates smoothly with no binding. The carburetor throttle should be fully closed with the actuator in the relaxed position (power off).

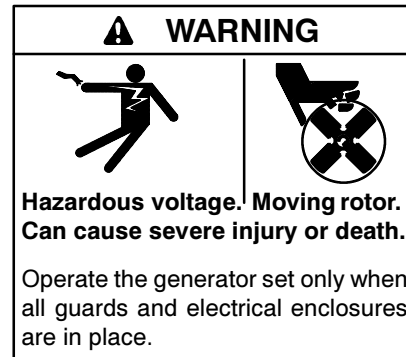

Short circuits. Hazardous voltage/current can cause severe injury or death. Short circuits can cause bodily injury and/or equipment damage. Do not contact electrical connections with tools or jewelry while making adjustments or repairs. Remove all jewelry before servicing the equipment.

Grounding electrical equipment. Hazardous voltage can cause severe injury or death. Electrocution is possible whenever electricity is present. Open the main circuit breakers of all power sources before servicing the equipment. Configure the installation to electrically ground the generator set, transfer switch, and related equipment and electrical circuits to comply with applicable codes and standards. Never contact electrical leads or appliances when standing in water or on wet ground because these conditions increase the risk of electrocution.

4. Select governor speed, 50 Hz/1500 rpm or 60 Hz/1800 rpm. Install a jumper across 50 Hz/60 Hz terminals on governor circuit board for 50 Hz operation. DO NOT jumper 50 Hz/60 Hz terminals for 60 Hz operation. See Figure 5-58. If generator speed (frequency) is changed, the voltage regulator also requires adjustment. See voltage regulator adjustment information in this section.

5. Turn gain potentiometer to setting 3 (0 = minimum and F = maximum gain).
6. Start generator set and apply full load.
7. Rotate gain potentiometer clockwise until actuator lever starts to oscillate, then rotate gain potentiometer counterclockwise until actuator lever stabilizes. Perform same adjustment at different loads (3/4, 1/2, 1/4, and no-load).

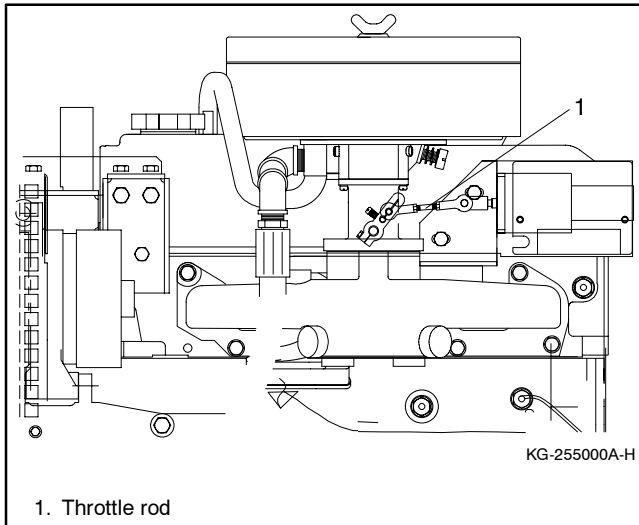

Figure 5-57 Governor Actuator/Throttle Rod, 18 kW

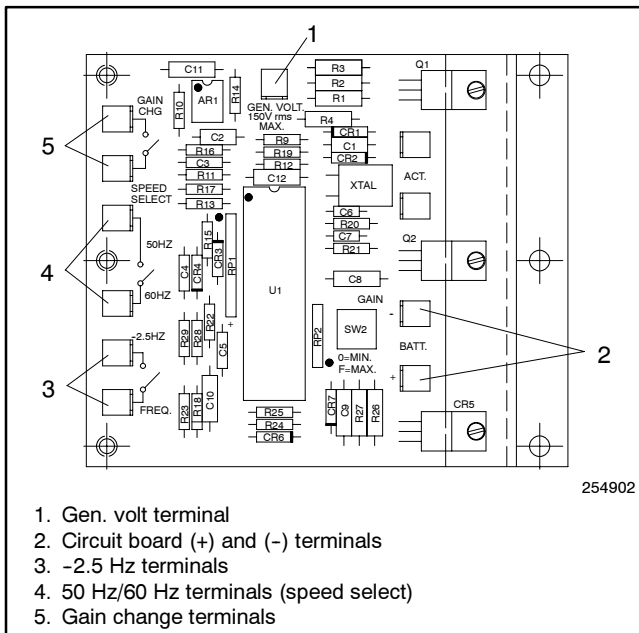
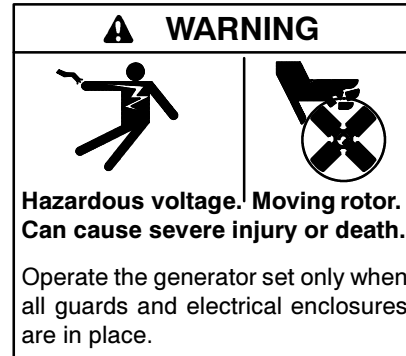

Figure 5-58 Governor Circuit Board

Governor Adjustment Procedure, 18 kW

Note: The -2.5 Hz/FREQ terminals on the governor circuit board change engine speed during voltage regulator adjustment. Do not tamper with these terminals during governor adjustment.



Short circuits. Hazardous voltage/current can cause severe injury or death. Short circuits can cause bodily injury and/or equipment damage. Do not contact electrical connections with tools or jewelry while making adjustments or repairs. Remove all jewelry before servicing the equipment.

Grounding electrical equipment. Hazardous voltage can cause severe injury or death. Electrocutation is possible whenever electricity is present. Open the main circuit breakers of all power sources before servicing the equipment. Configure the installation to electrically ground the generator set, transfer switch, and related equipment and electrical circuits to comply with applicable codes and standards. Never contact electrical leads or appliances when standing in water or on wet ground because these conditions increase the risk of electrocution.

1. Verify that swivel on actuator arm is fully threaded on actuator shaft and secured with locknut.
2. Adjust throttle rod assembly using following procedure:
 - a. Back out the idle adjust screw.
 - b. Test the throttle actuator position. Hold the linkage in the full, open position. Release the linkage forcing the spring to snap it back to the idle position. Listen for a click as the linkage snaps back to the idle position.
 - c. Adjust governor linkage length by turning the threaded rod 1/2 turn at a time and listen for a dull click. The dull click indicates the throttle plate is striking the carburetor bore.
 - d. Lengthen governor linkage by turning the threaded rod 1/2 turn at a time and listen for a sharp click. The sharp click indicates the actuator is stopping the throttle plate just short of striking the carburetor bore. Set the linkage at this point.

e. For maximum response, the actuator threaded rod must be about 90 degrees (perpendicular) to the throttle lever arm at no load rated rpm.

3. When throttle rod is set to correct length, tighten ball joint locknuts to maintain rod length. When correctly adjusted, the throttle linkage operates smoothly with no binding. The carburetor throttle fully closes with the actuator in the relaxed, power off position.

4. Select governor speed, 50 Hz/1500 rpm or 60Hz/1800 rpm. Install a jumper across 50 Hz/60 Hz terminals on governor circuit board for 50 Hz operation. DO NOT jumper 50 Hz/60 Hz terminals for 60 Hz operation. See Figure 5-58. If generator speed (frequency) is changed, the voltage regulator also requires adjustment. See voltage regulator adjustment information in this section.

5. Turn gain potentiometer to 3 (0 = minimum and F = maximum gain).

6. Start generator set and apply full load.

7. Rotate gain potentiometer clockwise until actuator lever starts to oscillate, then rotate gain potentiometer counterclockwise until actuator lever is stable. Perform same adjustment at the following loads (3/4, 1/2, 1/4, and no-load).

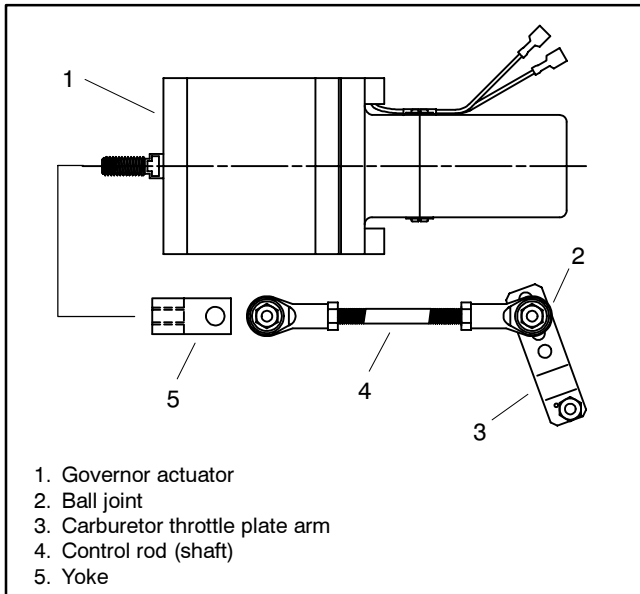

Figure 5-59 Governor Actuator/Throttle Rod, 18RY

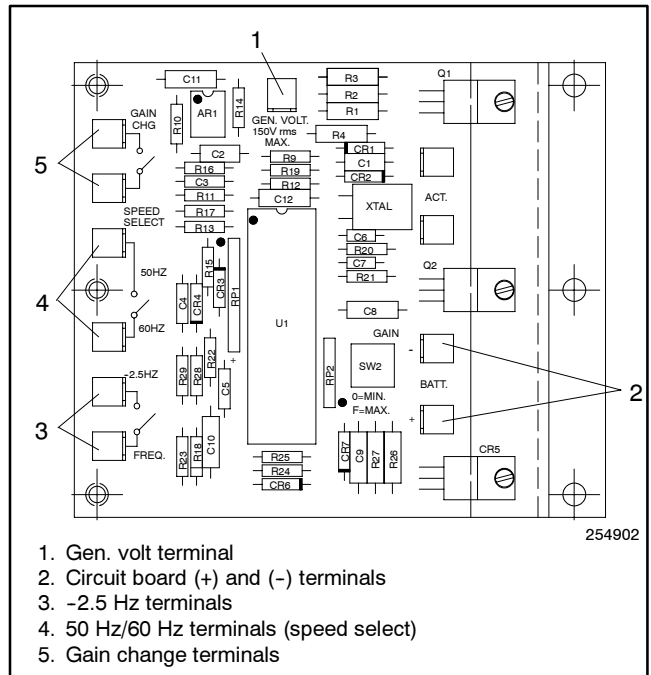

Figure 5-60 Governor Circuit Board

5.15.3 Electronic Governor (A-249922) Magnetic Pickup

Governor Adjustment Procedure

The first adjustment is the governor-to-carburetor control rod adjustment. Connect control rod to the second hole from top of carburetor throttle plate arm. Manually move linkage assembly toward governor actuator and adjust rod ball joint so that the hole lines up with the governor actuator arm yoke. Install hardware. See Figure 5-61.

The magnetic pickup air gap is 0.37 mm (0.015 in.) 0.127 mm (±0.005 in.).

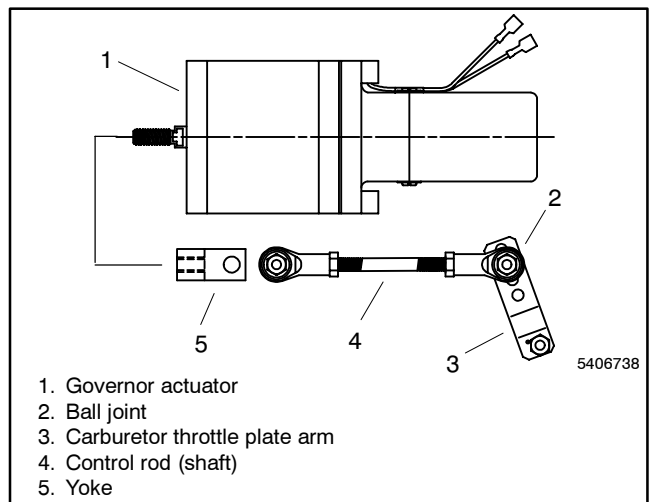

Figure 5-61 Governor Actuator Linkage

To perform a high speed adjustment, perform the following steps.

1. Adjust carburetor fuel mixture. See Section 3, Scheduled Maintenance.
2. Attach a frequency meter to output leads (recommended) or connect tachometer to the engine. Start and run the generator until unit reaches normal operating temperature.
3. Adjust the electronic **speed** potentiometer to obtain a full load engine speed of 1800 rpm (60 Hz). See Figure 5-62.
4. Apply approximately 1/4 load. Increase electronic governor **gain** potentiometer until just before hunting/surging begins.
5. Manually move linkage toward governor actuator momentarily and note result. Governor should react without hunting/surging. Readjust, if necessary, to obtain this condition.
6. Turn **gain** potentiometer back 5-10% to allow for smooth operation during a cold start.

Note: If instability occurs during a cold operation before generator set is at normal operating temperature, turn gain potentiometer back an additional 5-10%.

7. STOP generator set.

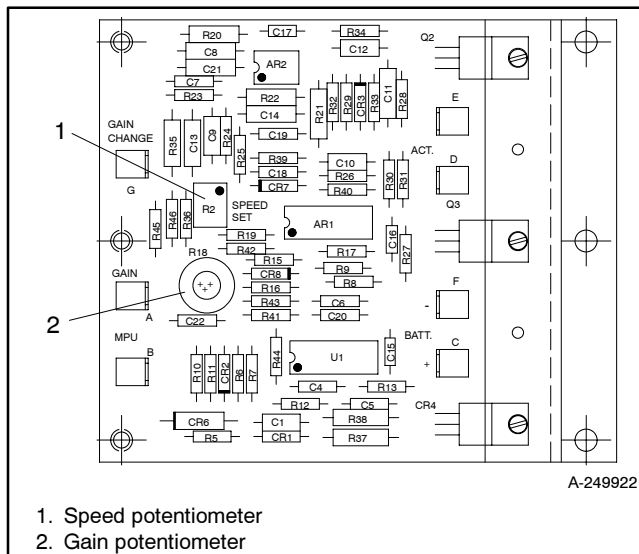

Figure 5-62 Governor Adjustment

5.15.4 Electronic Governor, Kohler Governor Magnetic Pickup

Introduction

The governor system consists of an electronic isochronous governor, an electromechanical stepper motor, and a magnetic pickup. The magnetic pickup supplies electrical pulses to the isochronous governor control unit each time one of the ring gear teeth passes the pickup. The control unit then compares the frequency of these pulses to a preset reference and provides a signal to the stepper motor which in turn controls the carburetor throttle position and hence the engine speed. This is a closed-loop system and typically provides steady state speed regulation of $\pm 0.25\%$.

The factory sets the electronic governor and it normally requires no further adjustment. If generator set operates erratically, check the following items BEFORE readjustment.

1. Check electrical connections. Check the stepper motor, controller box, and governor connector (inside the controller) for clean and tight connections.
2. Check magnetic pickup connections. Poor connections may cause an erratic signal. As long as this signal is being received, the unit will not shut down because of loss of pickup.
3. Check electrical ground connections. Provide a good DC ground to the controller assembly and governor circuit.
4. Check for dirt buildup on magnetic pickup. Metal filings or caked-on dirt/grease decrease the output signal of magnetic pickup.
5. Check for stepper motor/throttle shaft coupling wear. If the roll pin has caused wear to the slot of the stepper motor coupling, loosen coupling screw and move coupling so that the roll pin is positioned at a point in stepper motor coupling without wear. Tighten coupling screw.

Use the following adjustment procedure if the governor has been removed or tampered with.

Governor Adjustment Procedure

1. Check the governor actuator shaft to carburetor throttle shaft adjustment. For correct engagement, shafts must be concentric. Throttle plate position can be either open or closed during assembly. Carburetor throttle shaft pin must be in the slot of the stepper motor coupling with the pin in the middle of the depth slot. No other adjustment is necessary or possible with this arrangement.

Note: The governor stepper motor functions with steady and smooth movement during operation. If movement of stepper motor is erratic, or large changes in movement occur, check for shaft alignment, check for excessive coupling slot wear, and check for broken or loose wiring including plug connections.

2. Test stepper motor operation by disconnecting magnetic pickup leads.
3. Manually move the throttle shaft/governor stepper motor fully counterclockwise (closed throttle).
4. Start generator set. Stepper motor initially moves clockwise (wide open throttle) and then rotates completely counterclockwise. The stepper motor remains in this position.
5. STOP generator set. If stepper motor fails this test, replace stepper motor.
6. Reconnect magnetic pickup leads.

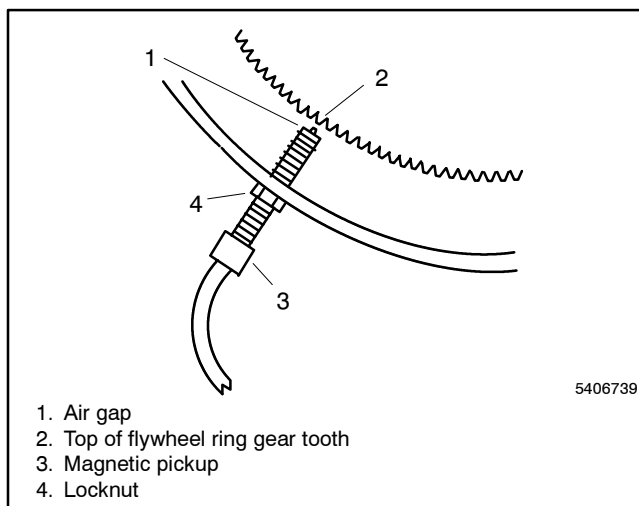

Figure 5-63 Magnetic Pickup Air Gap

7. Verify the magnetic pickup air gap is 1.02 ± 0.127 mm (0.040 ± 0.005 in.). See Figure 5-63.

Verify operation of the magnetic pickup by connecting voltmeter to magnetic pickup leads. See Figure 5-64. During engine cranking, voltage must be 1.75 volts AC minimum. Replace magnetic pickup if incorrect voltage is measured.

8. Adjust carburetor fuel mixture. See Section 3, Scheduled Maintenance.

Note: Hunting/surging problems thought to be caused by the governor are often actually linked to carburetor adjustment. Correctly adjust carburetor before continuing to next step.

9. Attach a frequency meter to AC output leads.
10. Start and run the generator until unit reaches normal operating temperature (approximately 5-10 minutes).

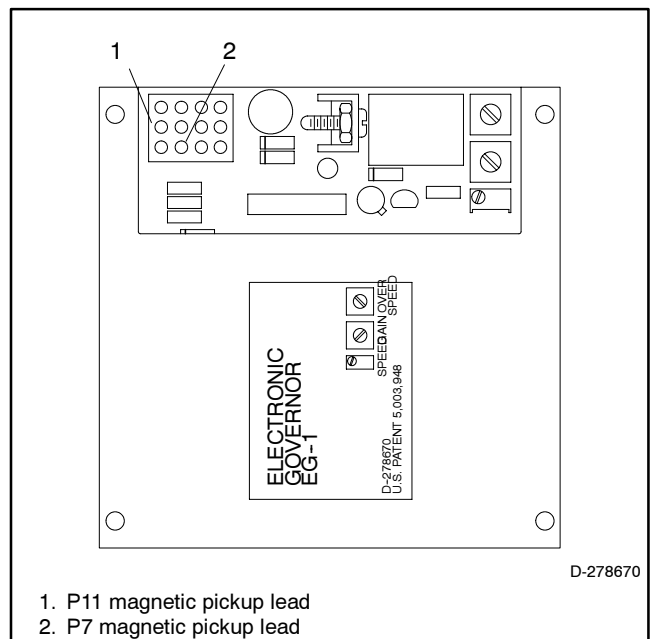

Figure 5-64 Magnetic Pickup Leads

11. Adjust the electronic governor **speed** potentiometer to obtain a full load engine speed of 60 Hz (1800 rpm) on 60 Hz models and 50 Hz (1500 rpm) on 50 Hz models. See Figure 5-65. Turn potentiometer clockwise to increase frequency and counterclockwise to decrease frequency.

12. Check stability with generator set running and with no load applied. If generator set has unstable speed or hunting/surging, turn **gain** potentiometer approximately 1/8 turn counterclockwise or until the generator set becomes stable where there is no hunting/surging. Observe frequency reading. Repeat step 5 as necessary.

13. Apply rated load to generator set and observe frequency reading. No-load and full-load frequencies should be within $\pm 5\%$ of desired frequency. If not within $\pm 5\%$ of desired frequency, check that the carburetor throttle plate opens fully and does not stick, and check that carburetor is correctly adjusted (see Section 3).

Note: Check for hunting/surging at full load. Turn **gain** potentiometer counterclockwise in 1/8-turn increments until generator set stabilizes.

14. Remove load and observe frequency. Frequency should return to value stated in speed adjustment (step 5). Gain adjustment *may* affect generator set speed/frequency. If speed changes, repeat step 5.

Note: Do not repeat gain adjustments after speed adjustments as speed adjustments have no affect on gain adjustments.

15. With unit running check overspeed cutout point. Manually move the throttle shaft/governor stepper motor coupling clockwise (as viewed from the back of the governor stepper motor). See Figure 5-66. Do not use **speed**-adjustment potentiometer to check the overspeed cutout point. Observe frequency meter and note frequency at which generator set shuts down. Factory setting is 72 Hz for 60 Hz models and 62 Hz for 50 Hz models, or 120% of rated speed/frequency.

Note: The Kohler electronic governor has an overspeed potentiometer on the circuit board. To avoid unwanted shutdowns verify that the governor and the controller are both set for the same shutdown setting. See Figure 5-65 for potentiometer location.

Note: Reset overspeed after making any speed adjustments.

Note: Turn overspeed potentiometer counterclockwise to increase overspeed cutout point and clockwise to decrease overspeed cutout point. Readjust **overspeed** potentiometer and repeat procedure to obtain the desired overspeed cutout point.

16. STOP generator set.

If after performing governor adjustments the generator set is not within the stated specifications, repeat steps 5-9. If repeating step 5-9 fails to bring generator set within electronic governor specifications, replace governor controller circuit board.

See appropriate wiring diagram in Wiring Diagram Manual for electronic governor wiring.

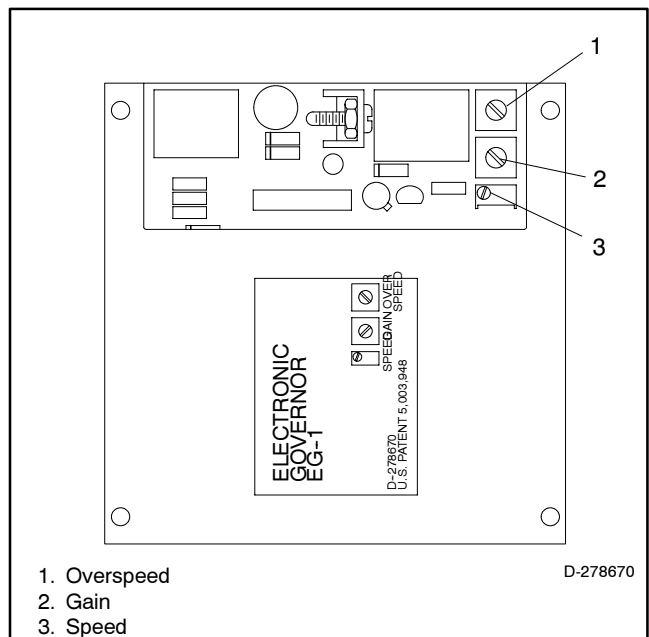

Figure 5-65 Governor Adjustments

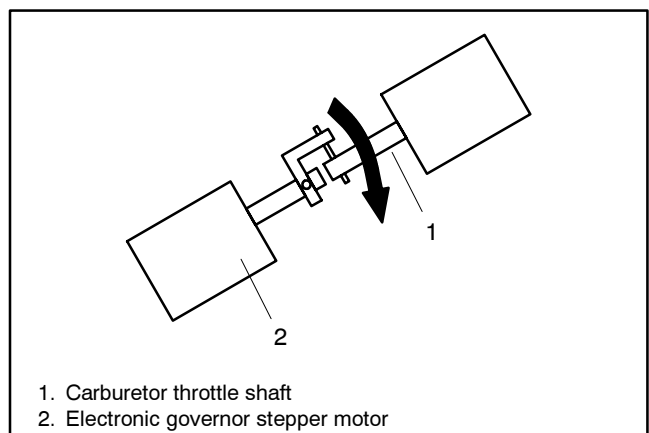

Figure 5-66 Manually Moving Stepper Motor

5.16 Cyclic Crank Board Test Procedure

The cyclic crank circuit board, located in the controller, allows adjustment of the cranking cycle for improved starter motor engagement. See Section 2, Relay Controller Operation, and Figure 5-67. The factory setting is eight seconds *on* time and 3 seconds *off* time. If the cranking cycle seems too short, check the condition of the battery before readjusting the board. Timing decreases if the battery charge is too low. It is possible to vary *on/off* cycles from 1 to 60 seconds. Increase the *on* or *off* time periods by rotating the potentiometer clockwise. If the generator engine does not go through the cyclic crank routine during starting, verify that the cyclic crank board adjustment or setting is correct. The cyclic crank feature does not operate when both potentiometers are in the full counterclockwise position. If the cyclic crank circuit board is correctly adjusted but the engine does not go through the preferred crank cycle, test the board as described in the following procedure.

Equipment needed:

- 12-volt battery or DC power supply
- DC voltmeter

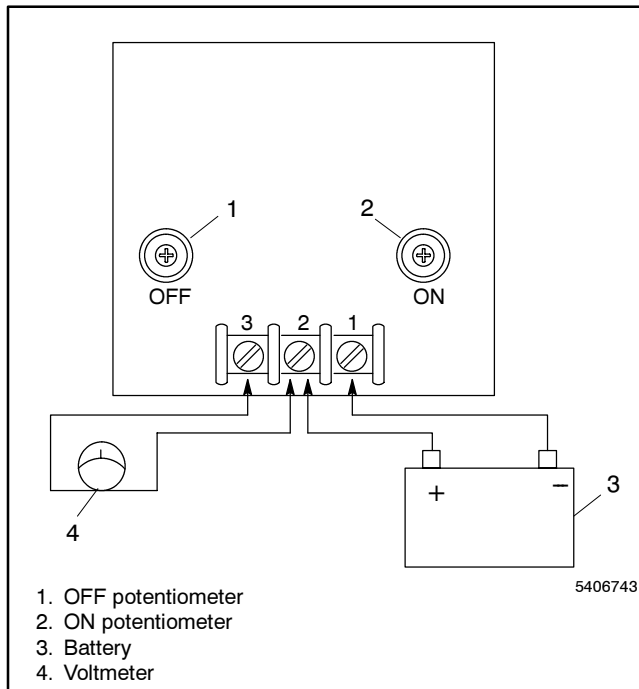
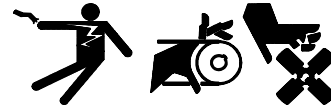

Figure 5-67 Cyclic Crank Board Test Connections

⚠ WARNING



Accidental starting.
Can cause severe injury or death.

Disconnect the battery cables before working on the generator set. Remove the negative (-) lead first when disconnecting the battery. Reconnect the negative (-) lead last when reconnecting the battery.

Disabling the generator set. Accidental starting can cause severe injury or death. Before working on the generator set or connected equipment, disable the generator set as follows: (1) Move the generator set master switch to the OFF position. (2) Disconnect the power to the battery charger. (3) Remove the battery cables, negative (-) lead first. Reconnect the negative (-) lead last when reconnecting the battery. Follow these precautions to prevent starting of the generator set by an automatic transfer switch, remote start/stop switch, or engine start command from a remote computer.

⚠ WARNING

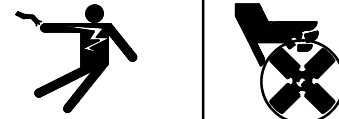

Hazardous voltage. Moving rotor.
Can cause severe injury or death.

Operate the generator set only when all guards and electrical enclosures are in place.

Grounding electrical equipment. Hazardous voltage can cause severe injury or death. Electrocutation is possible whenever electricity is present. Open the main circuit breakers of all power sources before servicing the equipment. Configure the installation to electrically ground the generator set, transfer switch, and related equipment and electrical circuits to comply with applicable codes and standards. Never contact electrical leads or appliances when standing in water or on wet ground because these conditions increase the risk of electrocution.

Short circuits. Hazardous voltage/current can cause severe injury or death. Short circuits can cause bodily injury and/or equipment damage. Do not contact electrical connections with tools or jewelry while making adjustments or repairs. Remove all jewelry before servicing the equipment.

1. Place the generator set master switch in the OFF position.
2. Disconnect generator set engine starting battery, negative (-) lead first. Disconnect power to battery charger, if equipped.
3. Disconnect leads connected to terminals 1, 2, and 3 of the cyclic crank circuit board. Remove cyclic crank board from controller.
4. Connect a voltmeter across cyclic crank board terminals 2 and 3. Set voltmeter on 12–15 volt DC scale. Connect battery positive (+) terminal to circuit board terminal 2. Connect battery negative (-) terminal to cyclic crank terminal 1. See Figure 5-67.
5. When applying 12 volts DC to circuit board, voltmeter shows 12 volts DC for approximately eight seconds (factory crank setting), then no voltage for approximately 3 seconds (factory rest setting). This sequence continues for 30 seconds (8 on, 3 off, 8 on, 3 off, 8 on). The cyclic crank board may have been customer adjusted to provide longer or shorter crank/rest cycles.
6. If no voltage is read at the cyclic cranking board, verify that the battery is fully charged and the cyclic cranking board is correctly adjusted. The cyclic crank feature does not operate at low battery voltage or when both circuit board potentiometers are in the full counterclockwise position. If no voltage registers with the battery fully charged and the cyclic crank board correctly adjusted, replace the cyclic crank circuit board.

Section 6 Disassembly/Reassembly

6.1 Disassembly

6.1.1 10/12RY/RFY

Prior to disassembly, remove the generator set from any enclosure. Disconnect battery (negative (-) lead first), fuel line, exhaust system, remote switch, and load leads. In addition to the precautions included in the text, observe all safety precautions listed at the beginning of this manual during the disassembly/reassembly procedure.

⚠ WARNING



**Accidental starting.
Can cause severe injury or death.**

Disconnect the battery cables before working on the generator set. Remove the negative (-) lead first when disconnecting the battery. Reconnect the negative (-) lead last when reconnecting the battery.

Disabling the generator set. Accidental starting can cause severe injury or death. Before working on the generator set or connected equipment, disable the generator set as follows: (1) Move the generator set master switch to the OFF position. (2) Disconnect the power to the battery charger. (3) Remove the battery cables, negative (-) lead first. Reconnect the negative (-) lead last when reconnecting the battery. Follow these precautions to prevent starting of the generator set by an automatic transfer switch, remote start/stop switch, or engine start command from a remote computer.

1. Place the generator set master switch in the OFF position.
2. Disconnect battery charger, if equipped.
3. Disconnect the generator set engine starting battery, negative (-) lead first.
4. Remove four screws securing junction box side panel. See Figure 6-1. Remove side panel.
5. Remove four mounting screws securing controller cover. Remove cover.
6. Disconnect brush leads and stator leads from connections in controller and junction box. Remaining leads may remain connected.
7. Remove two bolts securing vibromounts to skid. See Figure 6-1.

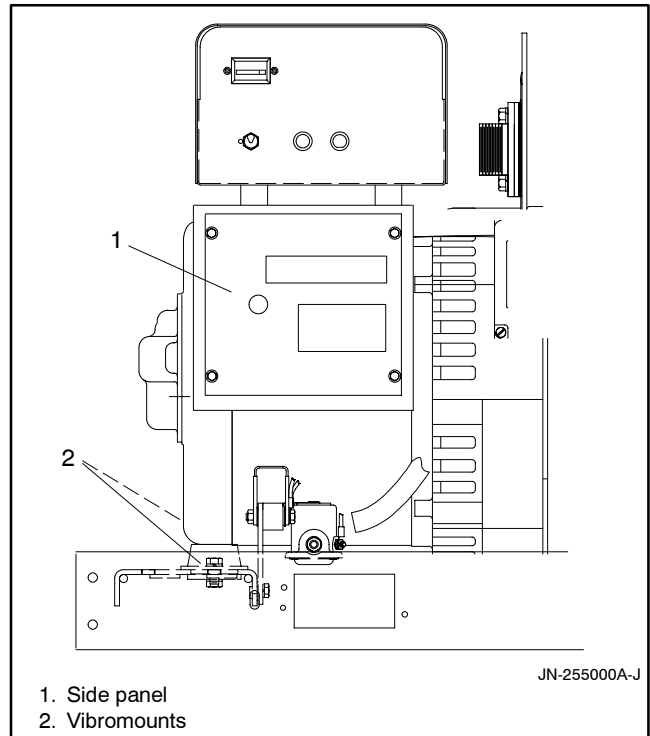

Figure 6-1 Junction Box Side Panels

8. Remove voltage regulator from end bracket by removing four mounting screws. Disconnect wiring harness to remove regulator. See Figure 6-2.
9. Use a hoist attached to generator lifting eye to raise generator high enough to place support block beneath engine oil pan. See Figure 6-3. To remove end bracket, place additional support beneath stator assembly.
10. Remove brush cover from end bracket by removing four mounting screws. See Figure 6-4.

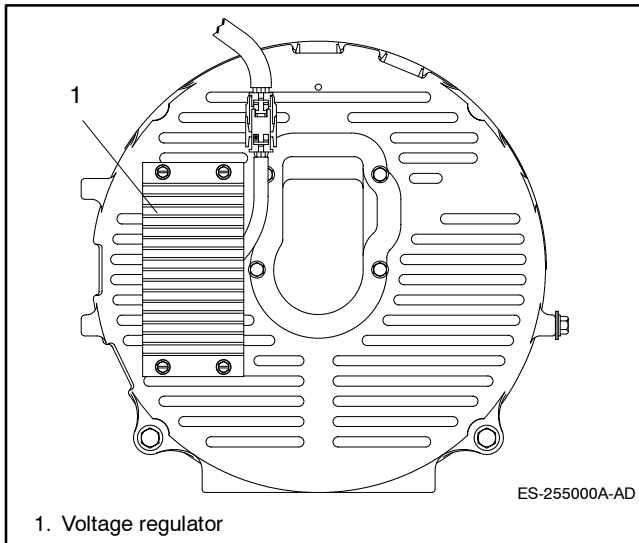

Figure 6-2 Generator End Bracket

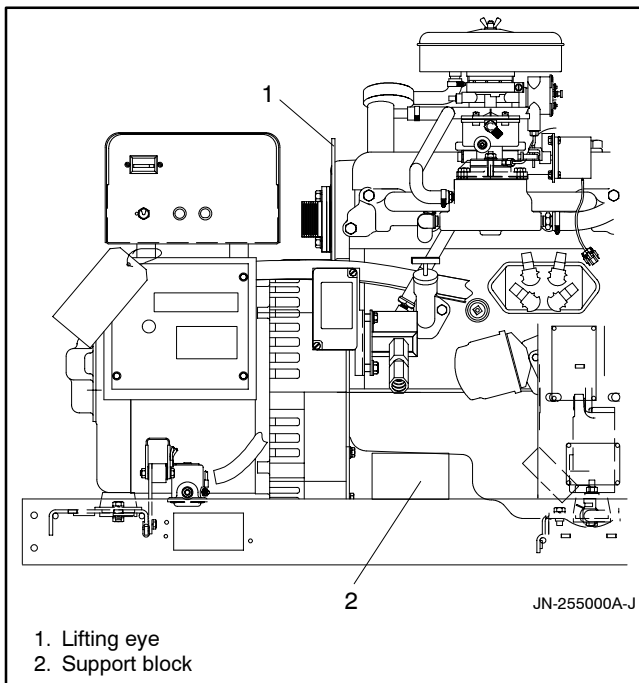

Figure 6-3 Engine Support Block

11. Gently grasp brush leads and raise brushes from slip rings. Lock brushes in raised position by inserting a retaining wire in hole in brush holder. See Figure 6-5.
12. Remove four overbolts securing controller and junction box panel to stator.
13. After removing overbolts move the controller/junction box assembly to the side for remaining steps.
14. Use a mallet to gently tap end bracket away from stator. See Figure 6-6. Carefully pull stator leads through port in end bracket during end bracket removal.

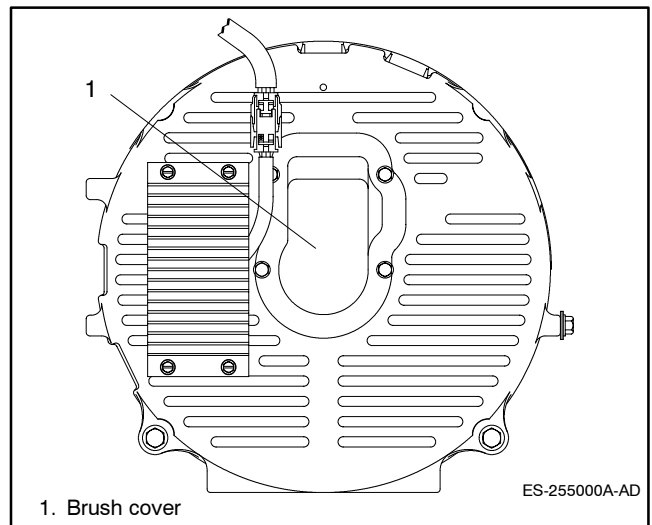

Figure 6-4 Generator End Bracket

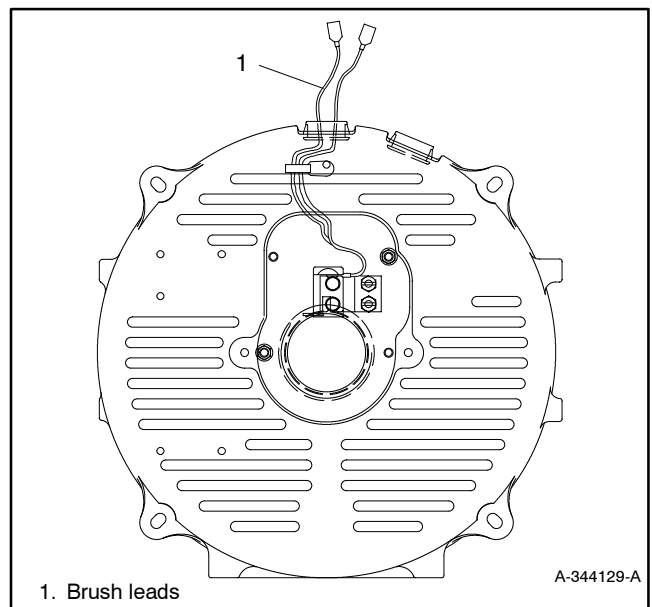

Figure 6-5 Generator End Bracket

15. Gently slide stator over rotor (armature). Be careful to avoid damaging rotor (armature) or stator during removal.
16. Remove four bolts and lock washers securing adapter panel to adapter. See Figure 6-7.
17. Remove three bolts and lock washers securing starter to adapter. See Figure 6-8.
18. Remove remaining adapter support bolts near starter assembly.
19. Remove two bolts and lock washers securing fuel pump to adapter. See Figure 6-9.

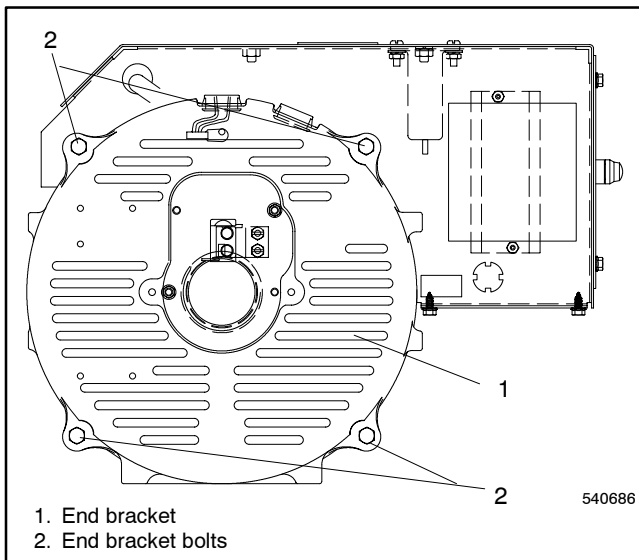

Figure 6-6 End Bracket

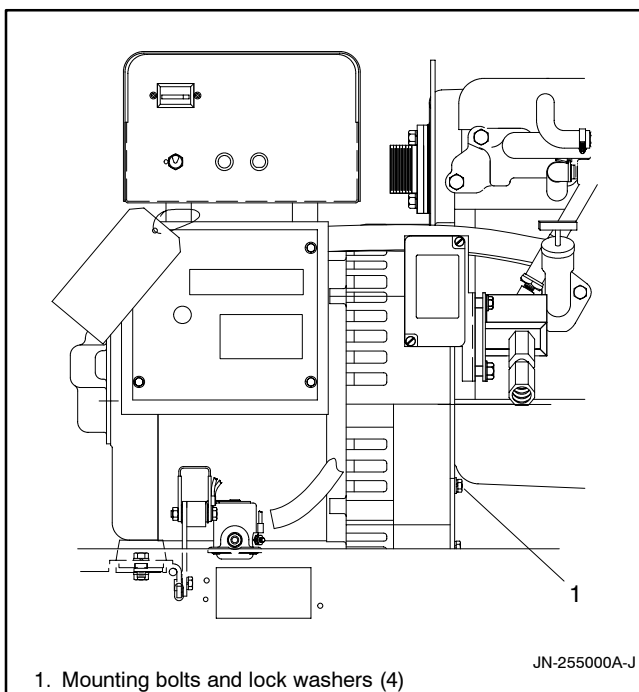

Figure 6-7 Adapter Panel

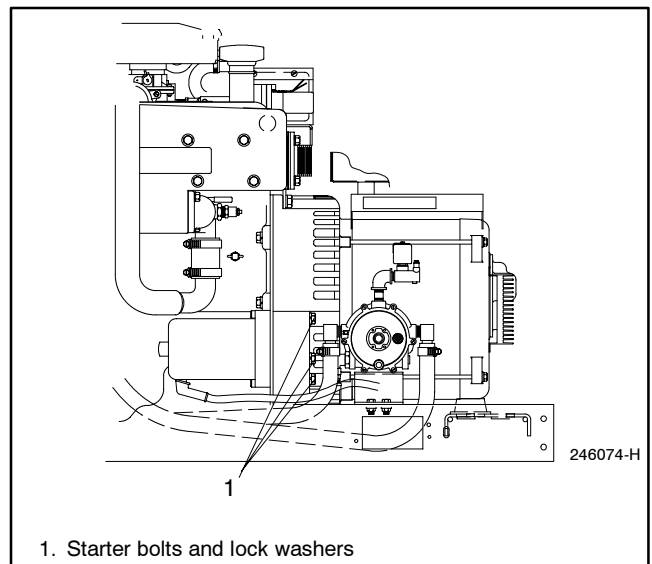

Figure 6-8 Engine Starter

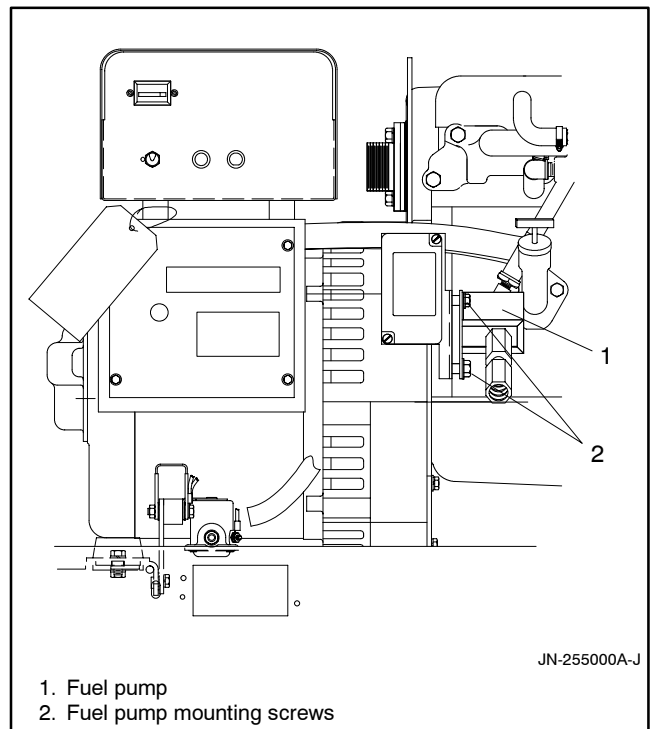

Figure 6-9 Fuel Pump

20. Move fuel pump away from adapter. Do not disconnect fuel line.

21. Remove two bolts securing lifting eye to adapter/engine. Remove lifting eye and adapter. See Figure 6-10.
22. Remove eight nuts with spacers securing generator drive discs. Support rotor during removal of hardware. After removing nuts remove rotor and one drive disc. See Figure 6-11.
23. Remove six bolts securing remaining drive disc to flywheel. Note position of spacers before removing drive disc. See Figure 6-12.

6.1.2 10/12RZ/RFZ

Remove the generator set from the enclosure prior to disassembly. Disconnect battery (negative (-) lead first), fuel line, exhaust system, remote switch, and load leads. In addition to the precautions included in the text, observe all safety precautions listed at the beginning of this manual during the disassembly/reassembly procedure.

⚠ WARNING

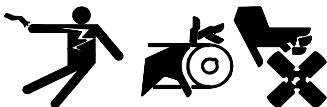

**Accidental starting.
Can cause severe injury or death.**

Disconnect the battery cables before working on the generator set. Remove the negative (-) lead first when disconnecting the battery. Reconnect the negative (-) lead last when reconnecting the battery.

Disabling the generator set. Accidental starting can cause severe injury or death. Before working on the generator set or connected equipment, disable the generator set as follows: (1) Move the generator set master switch to the OFF position. (2) Disconnect the power to the battery charger. (3) Remove the battery cables, negative (-) lead first. Reconnect the negative (-) lead last when reconnecting the battery. Follow these precautions to prevent starting of the generator set by an automatic transfer switch, remote start/stop switch, or engine start command from a remote computer.

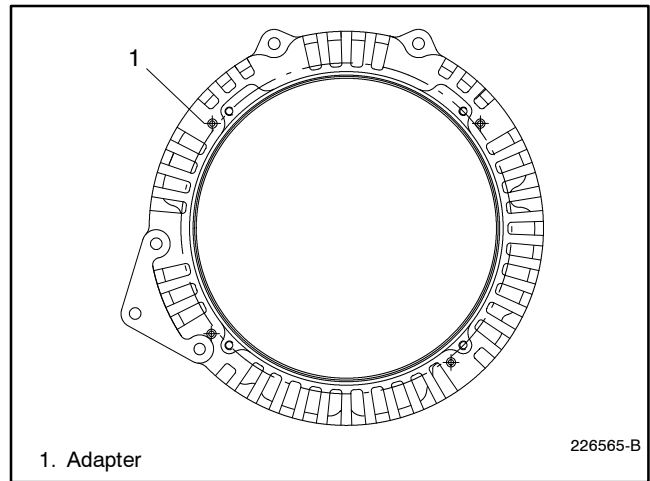

Figure 6-10 Engine Adapter

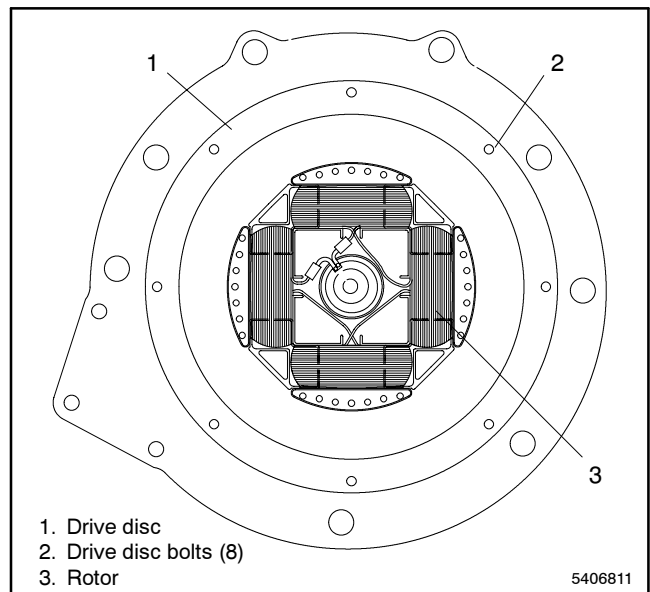

Figure 6-11 Drive Disc and Rotor

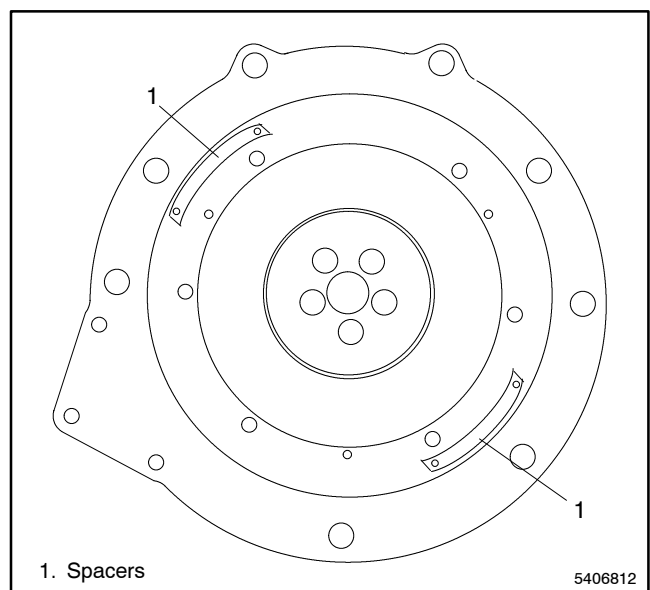

Figure 6-12 Engine Flywheel and Spacers

1. Place the generator set master switch in the OFF position.
2. Disconnect power to battery charger, if equipped.
3. Disconnect the generator set engine starting battery, negative (-) lead first.
4. Remove eight screws securing junction box side panels. See Figure 6-13. Remove side panels.
5. Remove four mounting screws securing controller cover. Remove cover.
6. Remove all generator leads from connections in junction box and controller. Remaining leads may remain connected.
7. Remove bolts securing junction box to adapter. See Figure 6-14. Remove voltage regulator circuit board to access inaccessible junction box mounting bolts.
8. Gently lift controller/junction box assembly away from generator. Support controller/junction box during remaining steps to prevent controller/junction box damage.

Note: For units equipped with a generator-mounted 5-light controller, disconnect all controller wiring from generator set and remove controller separately.

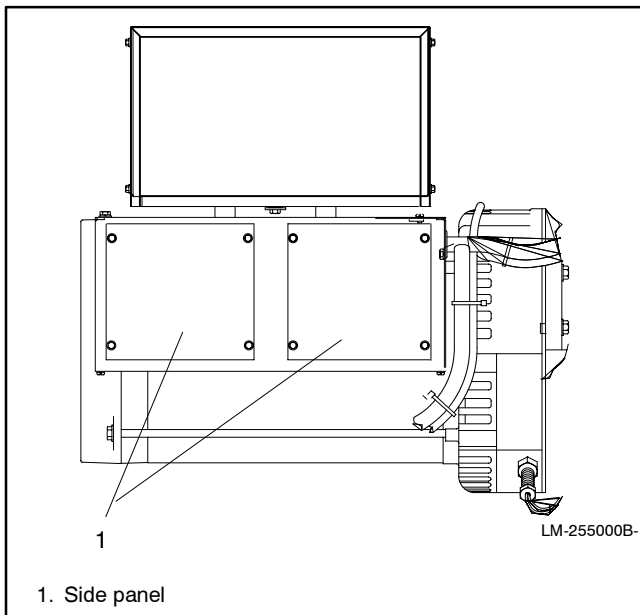

Figure 6-13 Junction Box Side Panels

9. Remove four screws securing louvered panel to end bracket. See Figure 6-14.
10. Remove two bolts securing vibromounts to skid. See Figure 6-15.

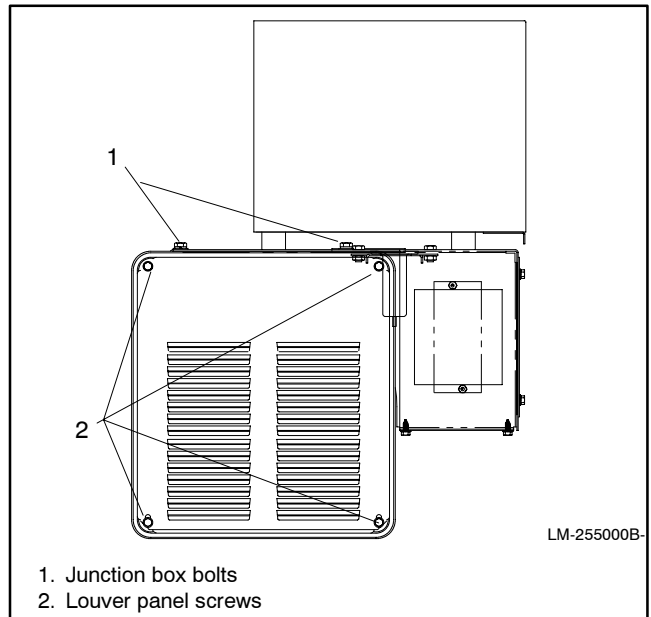

Figure 6-14 Junction Box Bolts

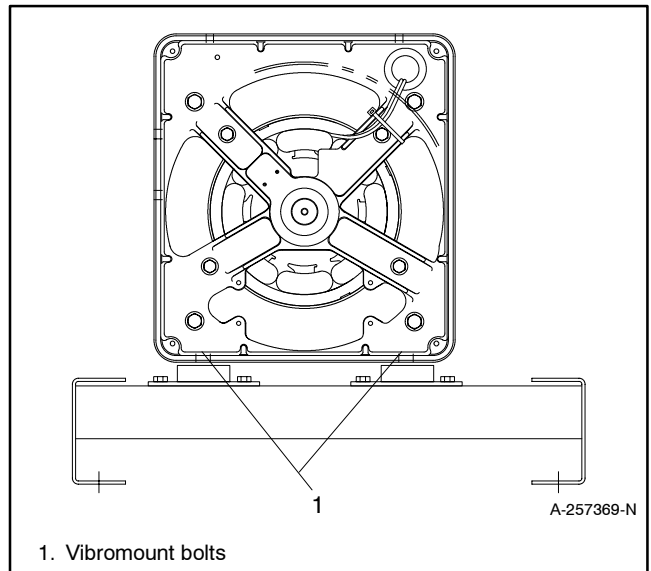

Figure 6-15 Vibromounts

11. Use a hoist attached to generator lifting eye to raise generator high enough to place support block beneath engine oil pan. See Figure 6-16. To remove end bracket place additional support beneath stator assembly.
12. Remove four overbolts securing end bracket. See Figure 6-17. Leave the exciter field attached to the end bracket. Disconnect leads 2, 16, and 24 from end bracket magnetic pickup.
13. Use a mallet to gently tap end bracket away from stator.

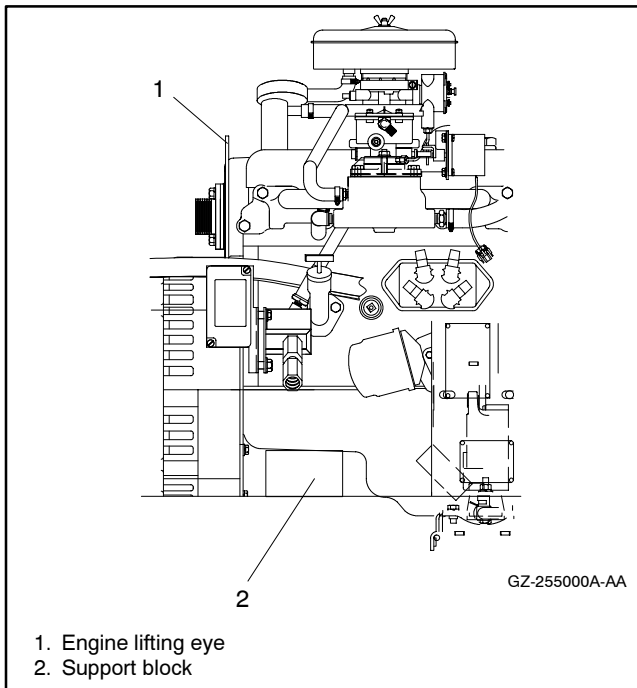

Figure 6-16 Support Block

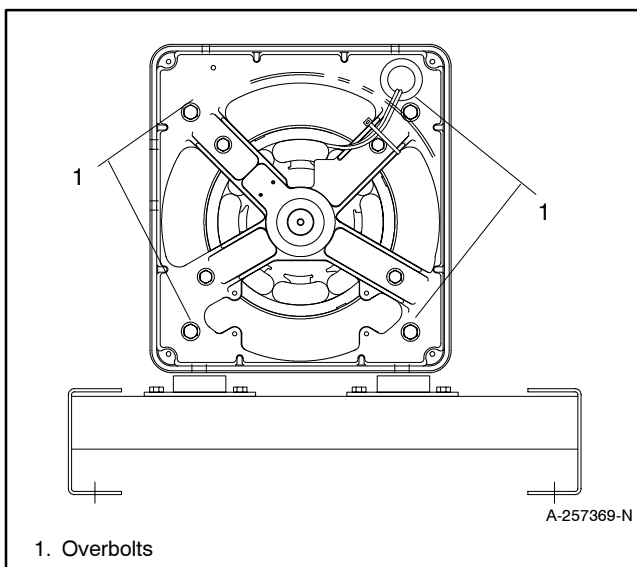

Figure 6-17 Overbolts

14. Use a hoist to support stator assembly and gently slide stator over rotor. Be careful to avoid damaging rotor or stator during removal.
15. Remove four bolts and lock washers securing adapter panel to adapter. See Figure 6-18.
16. Remove three bolts and lock washers securing starter to adapter. See Figure 6-19.
17. Remove remaining adapter support bolts near starter assembly.
18. Remove two bolts and lock washers securing fuel pump to adapter. See Figure 6-20. Move fuel pump away from adapter. Do not disconnect fuel line.
19. Remove two bolts securing lifting eye to adapter/engine. Remove lifting eye and adapter. See Figure 6-21.
20. Remove eight nuts and spacers securing generator drive discs. Support rotor during removal of hardware. When nuts are removed, remove rotor and one drive disc. See Figure 6-22.
21. Remove six bolts securing remaining drive disc to flywheel. Note position of spacers before removing drive disc. See Figure 6-23.

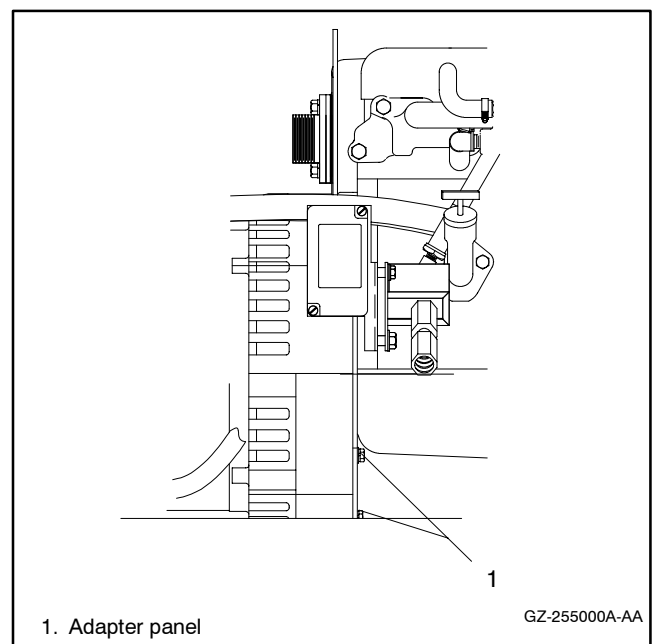

Figure 6-18 Adapter Panel

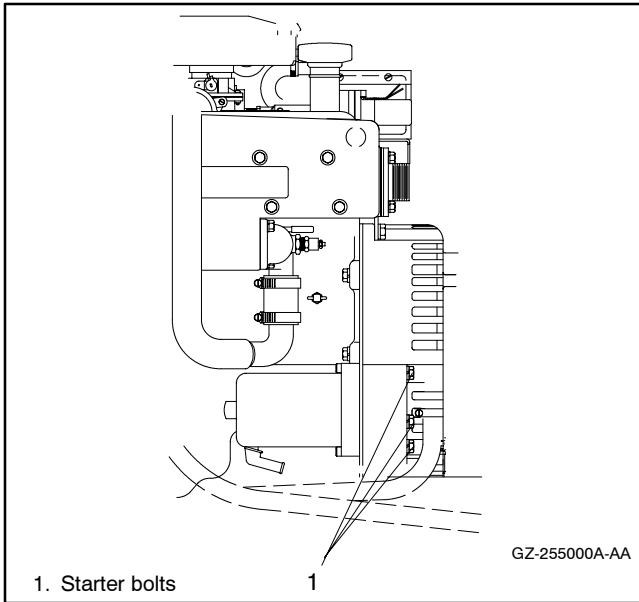

Figure 6-19 Engine Starter

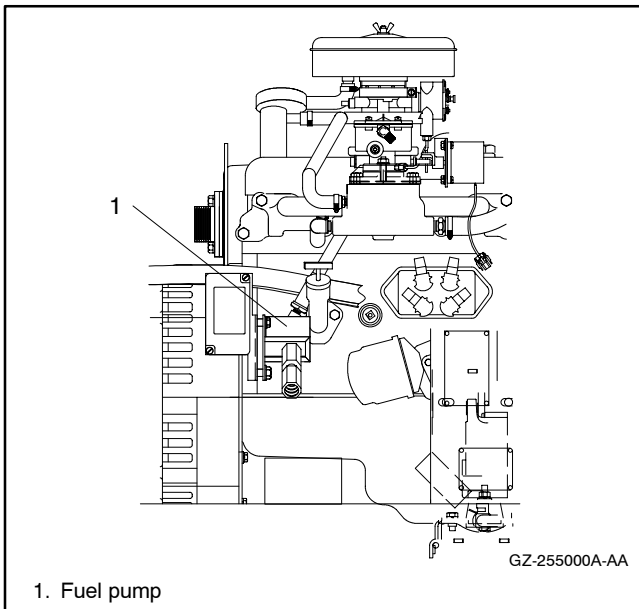

Figure 6-20 Fuel Pump

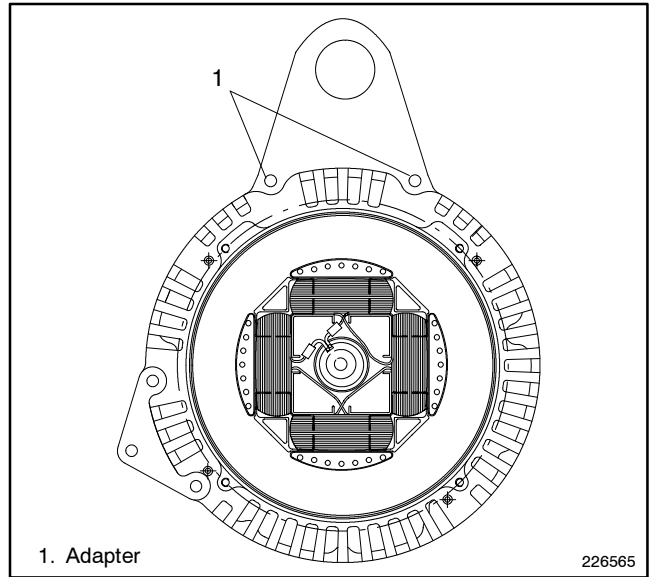

Figure 6-21 Adapter

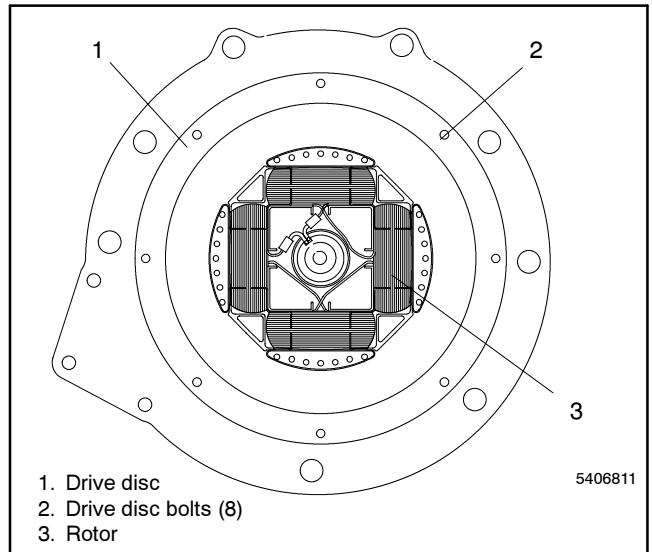

Figure 6-22 Drive Disc and Rotor

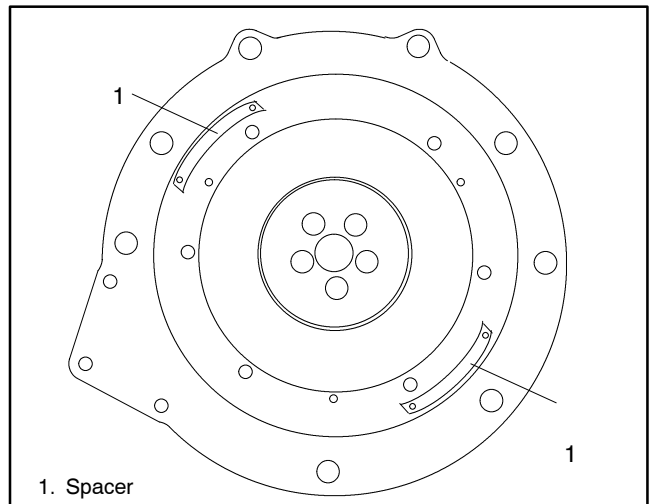

Figure 6-23 Engine Flywheel and Spacers

6.2 Reassembly

6.2.1 10/12RY/RFY

1. Secure drive disc to flywheel with six mounting bolts. Torque mounting bolts to 19 Nm (168 in. lb.).
2. Position spacers on drive disc exactly as recorded during disassembly. Use eight nuts and spacers to reattach remaining drive disc and rotor to drive disc installed in previous step. See Figure 6-24. Torque mounting bolts to 7.9 Nm (70 in. lb.).
3. Position adapter on engine. Attach lifting eye to adapter/engine with two mounting bolts and lock washers. See Figure 6-25. Reinstall magnetic pickup, if removed, and verify flywheel/magnetic pickup air gap of 0.51–1.27 mm (0.020–0.050 in.).
4. Attach fuel pump to adapter with two mounting screws.
5. Reconnect starter to adapter with three mounting screws and lock washers. Reinstall two adapter mounting bolts and lock washers in positions above starter.
6. Reattach adapter panel to adapter with four bolts and lock washers.
7. Use a hoist, if necessary, to support stator and gently slide stator over rotor.

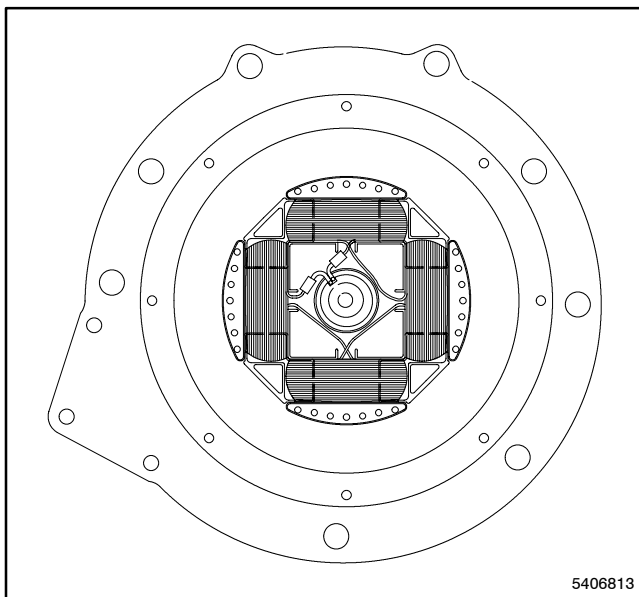

Figure 6-24 Drive Disc and Rotor

8. The alternator uses one of three end bracket configurations. If end bracket has a tolerance ring, refer to step a. If end bracket uses a continuous contour and a narrow groove for an O-ring, refer to step b. If end bracket uses a continuous contour with no groove, refer to step c.

Note: Do not apply lubricant to any parts during end bracket installation.

- a. **Tolerance ring end bracket:** Route stator leads through port in end bracket while positioning end bracket against stator. Install new tolerance ring in end bracket. Use a mallet, if necessary, to gently tap end bracket into position.

Note: Do NOT attempt to install end bracket on rotor by tightening overbolts. Tightening overbolts may cause damage to end bracket and/or generator adapter.

- b. **End bracket with groove:** Assemble new O-ring into end bracket bearing bore groove. Route stator leads through port in end bracket while positioning end bracket against stator. Align end bracket on stator assembly and rotor bearing. For precise fit, assemble the end bracket and rotor bearing at the same temperature. Ensure that stator shell notches, if present are on top and end bracket is correctly aligned. The complete assembly of the generator set requires correct alignment of these components.

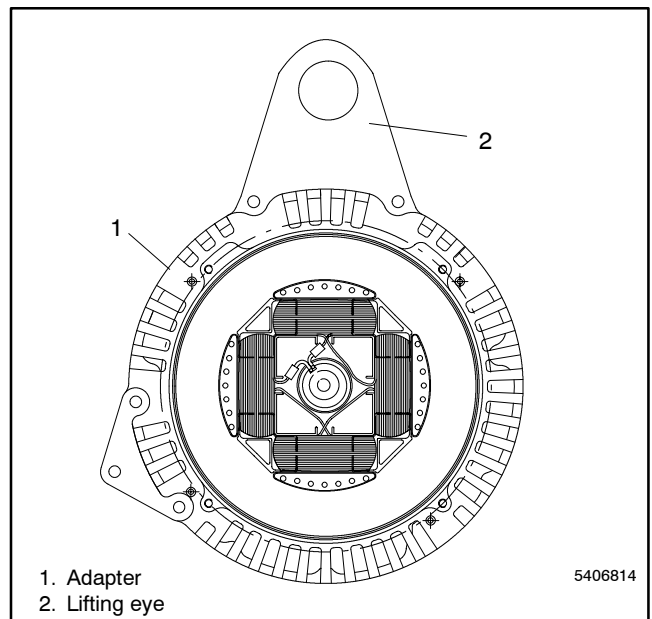

Figure 6-25 Lifting Eye

c. **End bracket without groove:** Route stator leads through port in end bracket while positioning end bracket against stator. Align end bracket on stator assembly and rotor bearing. For precise fit, assemble the end bracket and rotor bearing at the same temperature. Ensure that stator shell notches, if present, are to the top and end bracket is aligned. The complete assembly of the generator set requires correct alignment of these components.

9. Use a hard rubber or dead blow hammer to alternately strike end bracket using medium force blows. Use the rotating sequence shown in Figure 6-26 to install end bracket. With end bracket fully seated in stator assembly, install and tighten overbolts as described in step 10.

Note: Do NOT attempt to install end bracket on rotor by tightening overbolts. Tightening overbolts may cause damage to end bracket and/or generator adapter.

10. Position controller and junction box on stator. Install overbolts and tighten to 6.8 Nm (60 in. lb.) to secure end bracket and controller/junction box assembly.

11. Remove retainer wire securing brushes in brush holder. Verify that brushes are correctly positioned on rotor slip rings. See Section 5.12, Brushes. Position brush cover on end bracket and secure with mounting screws.

12. Replace junction box side panels and secure with original hardware.

13. Use a hoist to raise generator high enough to remove support blocks from beneath oil pan. Lower generator set onto skid and replace vibromount hardware. See Figure 6-27.

14. Reattach voltage regulator to end bracket and secure with screws and lock washer.

15. Reconnect wiring in controller and junction box which was disconnected during disassembly. Refer to wiring diagram in Wiring Diagram Manual.

16. Replace controller cover and secure with screws and lock washers.

17. Reconnect fuel line, exhaust system, remote switch, and load leads.

18. Reinstall generator set in enclosure, if applicable.

19. Check that the generator set master switch is in the OFF position.

20. Reconnect the generator set engine starting battery, negative (-) lead last. Reconnect power to battery charger, if equipped.

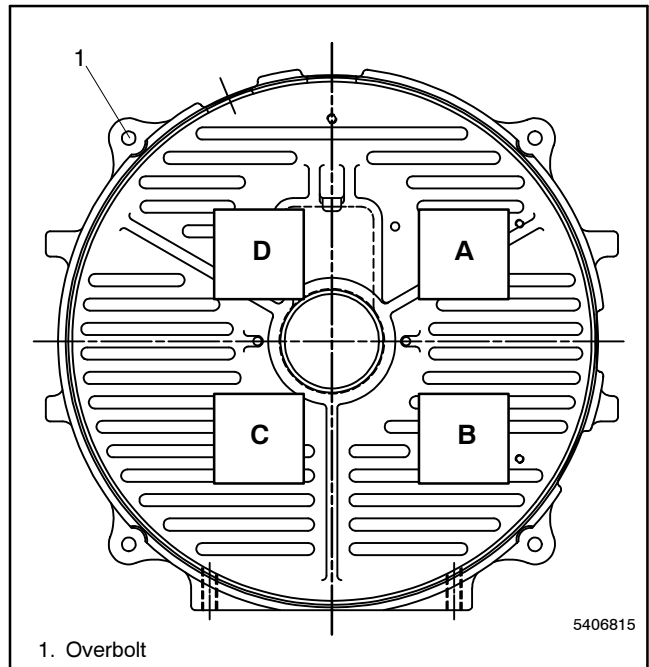

Figure 6-26 Flush Fit End Bracket

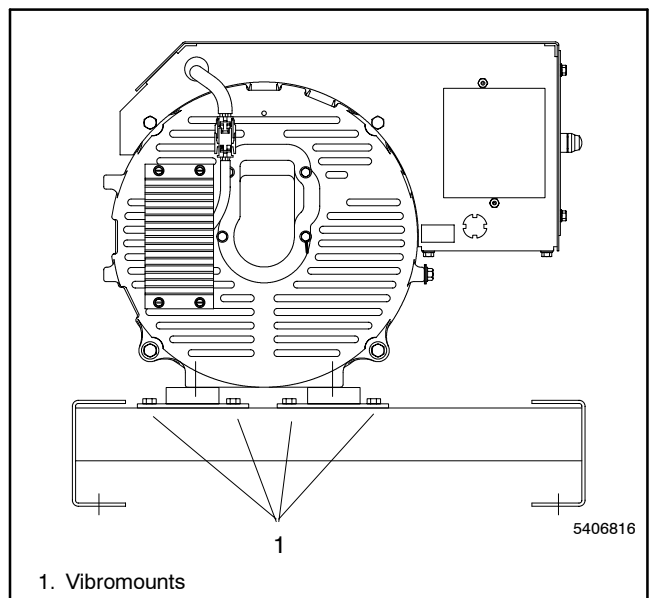

Figure 6-27 Mounting Hardware

6.2.2 10/12RZ/RFZ

1. Secure drive disc to flywheel with six mounting bolts. Torque mounting bolts to 19 Nm (168 in. lb.).
2. Position spacers on drive disc exactly as recorded during disassembly. Use eight nuts and spacers to reattach remaining drive disc and rotor to drive disc installed in previous step. See Figure 6-28. Torque mounting bolts to 7.9 Nm (70 in. lb.).
3. Position adapter on engine. Attach lifting eye to adapter/engine with two mounting bolts and lock washers. See Figure 6-29. Reinstall magnetic pickup, if removed, and verify flywheel/magnetic pickup air gap of 0.51–1.27 mm (0.020–0.050 in.).
4. Attach fuel pump to adapter with two mounting screws.
5. Reconnect starter to adapter with three mounting screws and lock washers. Reinstall two adapter mounting bolts and lock washers in positions above starter.
6. Reattach adapter panel to adapter with four bolts and lock washers.
7. Use a hoist to support stator and gently slide stator over rotor assembly.
8. The alternator uses one of three end bracket configurations. If end bracket is equipped with a tolerance ring, refer to step a. If end bracket uses a continuous contour and a narrow groove for an O-ring, refer to step b. If end bracket uses a continuous contour with no groove, refer to step c.

Note: Remove dirt and corrosion from bearing and end bracket. Replace O-ring if damaged.

- a. Tolerance ring end bracket: Route stator leads through port in end bracket while positioning end bracket against stator. Install new tolerance ring in end bracket. Use a mallet, if necessary, to gently tap end bracket into position.
- b. End bracket with groove: Assemble new O-ring into end bracket bearing bore groove. Route stator leads through port in end bracket while positioning end bracket against stator. Align end bracket on stator assembly and rotor bearing. For precise fit, assemble the end bracket and rotor bearing at the same temperature. Check that stator shell notches, if present, are on top and end bracket is aligned. The complete assembly of the generator set

requires correct alignment of these components.

Note: Damage to end bracket and/or generator adapter may result. Do NOT attempt to install end bracket on rotor by tightening overbolts.

- c. End bracket without groove: Route stator leads through port in end bracket while positioning end bracket against stator. Align end bracket on stator assembly and rotor bearing. For precise fit, assemble the end bracket and rotor bearing at the same temperature. Check that stator shell notches, if present, are to the top and end bracket is aligned. The complete assembly of the generator set requires correct alignment of these components.

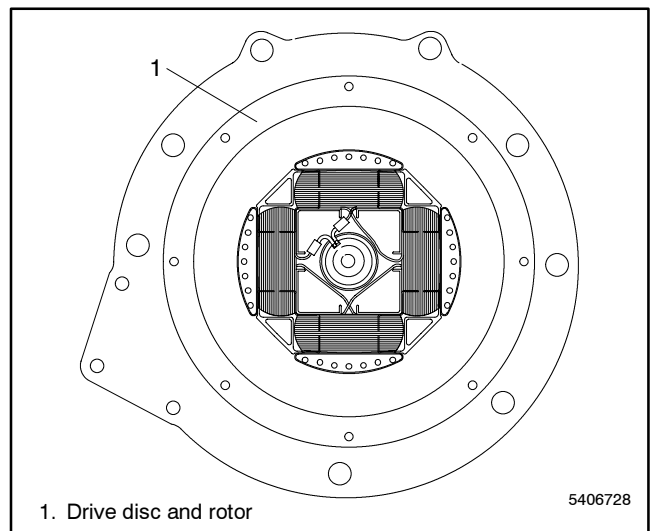

Figure 6-28 Drive Disc and Rotor

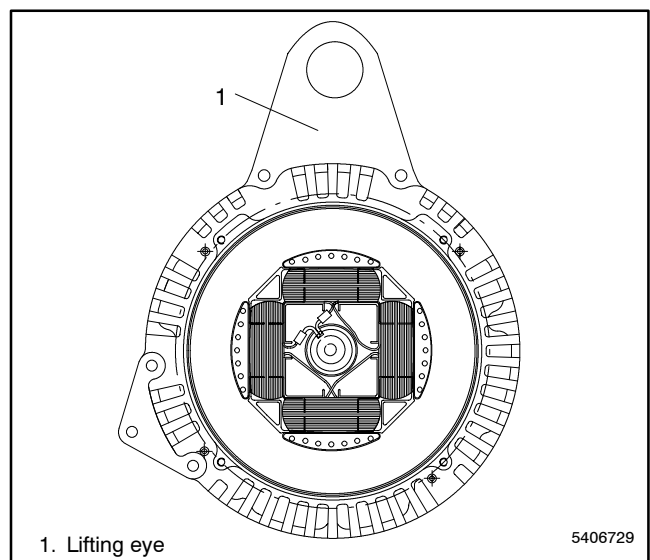

Figure 6-29 Lifting Eye

- Use a hard rubber or dead blow hammer to strike end bracket using medium force blows. Use the rotating sequence shown in Figure 6-30 to install end bracket. When end bracket is completely installed in stator assembly, install and torque overbolts as described in the next step.

Note: Do NOT attempt to install end bracket on rotor by tightening overbolts. Tightening overbolts may cause damage to end bracket and/or generator adapter.

Note: Do not apply lubricant to any parts during end bracket installation.

6.3 Disassembly, 18RY/RFY/RZ/RFZ

⚠ WARNING

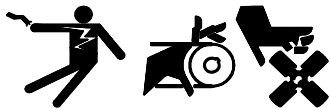

**Accidental starting.
Can cause severe injury or death.**

Disconnect the battery cables before working on the generator set. Remove the negative (-) lead first when disconnecting the battery. Reconnect the negative (-) lead last when reconnecting the battery.

Disabling the generator set. Accidental starting can cause severe injury or death. Before working on the generator set or connected equipment, disable the generator set as follows: (1) Move the generator set master switch to the OFF position. (2) Disconnect the power to the battery charger. (3) Remove the battery cables, negative (-) lead first. Reconnect the negative (-) lead last when reconnecting the battery. Follow these precautions to prevent starting of the generator set by an automatic transfer switch, remote start/stop switch, or engine start command from a remote computer.

- Place the generator set master switch in the OFF position.
- Disconnect power to battery charger, if equipped.
- Disconnect the generator set engine starting battery, negative (-) lead first.
- Disconnect exhaust system, load leads, and remote switch, if equipped.

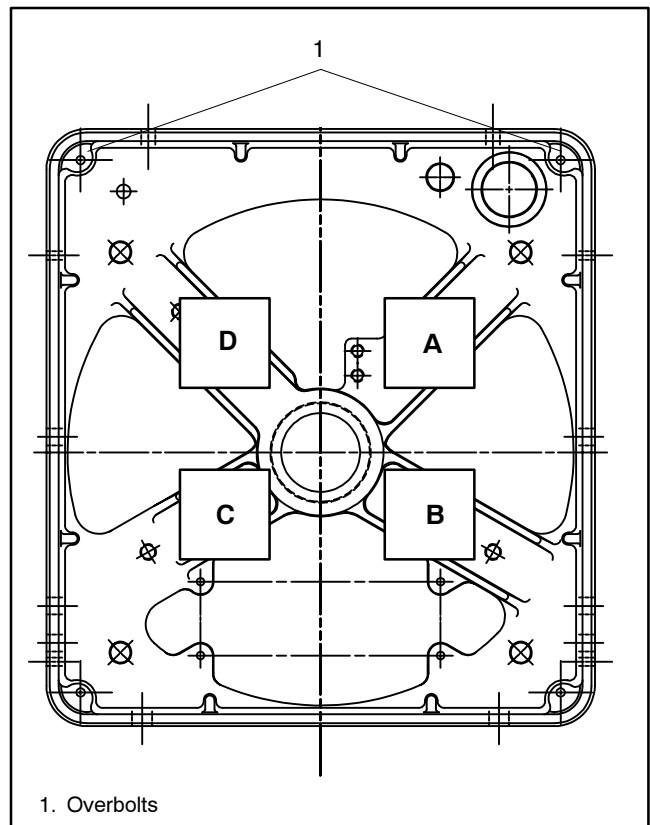
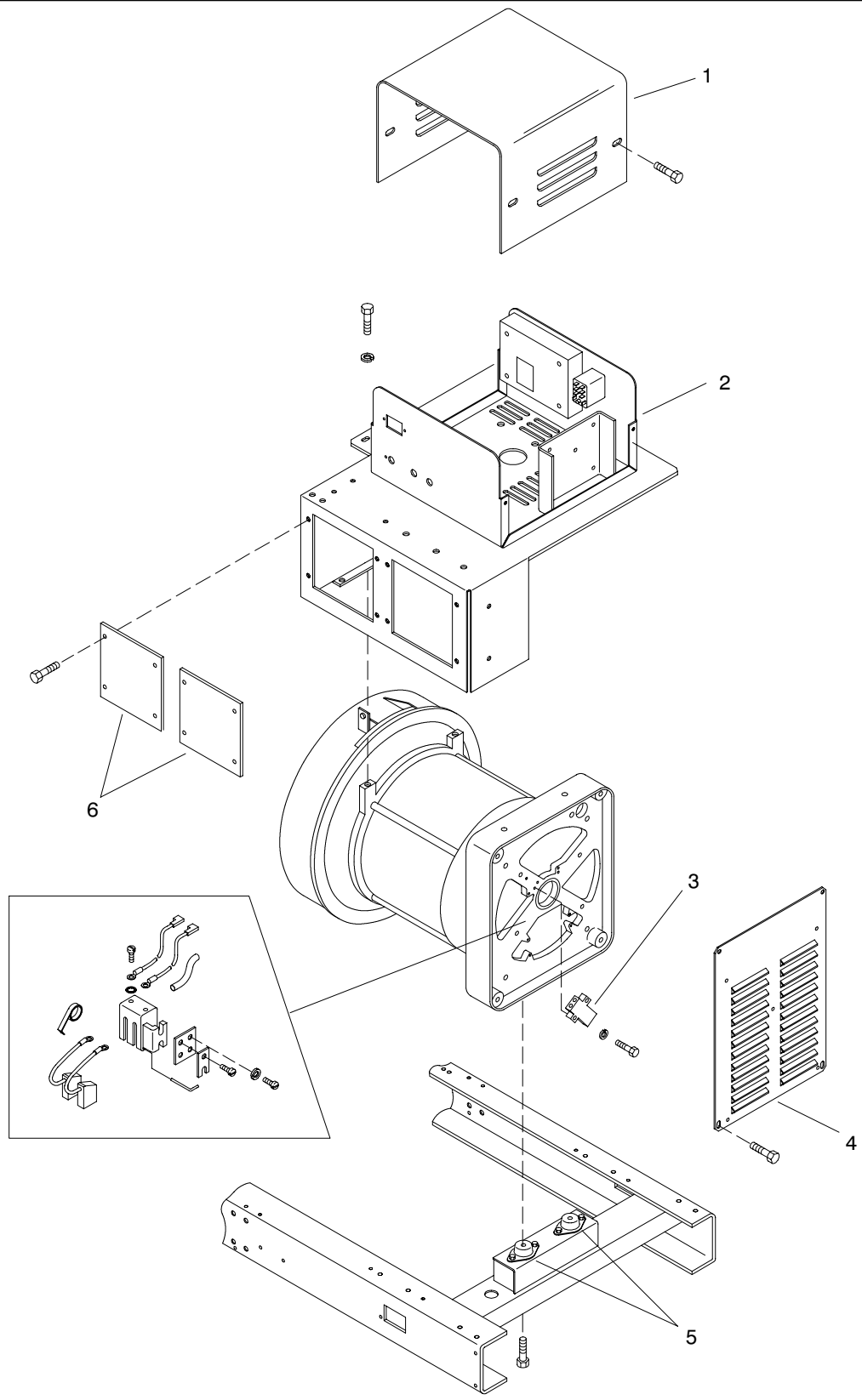

Figure 6-30 Flush-Fit End Bracket

- Remove mounting screws securing junction box side panels. See Figure 6-31. Remove side panels.
- Remove four mounting screws securing controller cover.
- Disconnect brush and stator leads from connections in controller and junction box. Remaining leads may remain connected.
- Remove the two bolts securing vibromounts to skid.
- Remove louver panel by removing four mounting screws. Gently grasp brush leads and raise brushes from slip rings. Lock brushes in raised position by inserting a retaining wire in hole in brush holder. Remove four mounting bolts securing junction box panel to stator. After bolts are removed, move the controller/junction box assembly to the side for remaining steps.
- Remove two screws and washers securing speed sensor to end bracket.
- Use a hoist attached to generator lifting eye to raise generator high enough to place support blocks beneath engine oil pan. To remove end bracket place additional support beneath stator assembly.



5406817

- 1. Controller cover
- 2. Controller/junction box assembly
- 3. Speed sensor

- 4. Louvered panel
- 5. Vibromount
- 6. Side panels

Figure 6-31 Removing Controller/Junction Box and Louvered Panel

12. Remove four overbolts securing end bracket to stator. Use a mallet to gently tap end brackets away from stator. Carefully pull stator and speed sensor leads through opening in end bracket during end bracket removal. See Figure 6-32.
13. Use a hoist, if necessary, to support stator and gently slide stator over rotor armature. Be careful to avoid damaging rotor armature or stator during removal.

14. Remove two screws securing generator fan guard. Remove fan guard.
15. Remove twelve screws securing adapter to flywheel housing. Remove adapter.

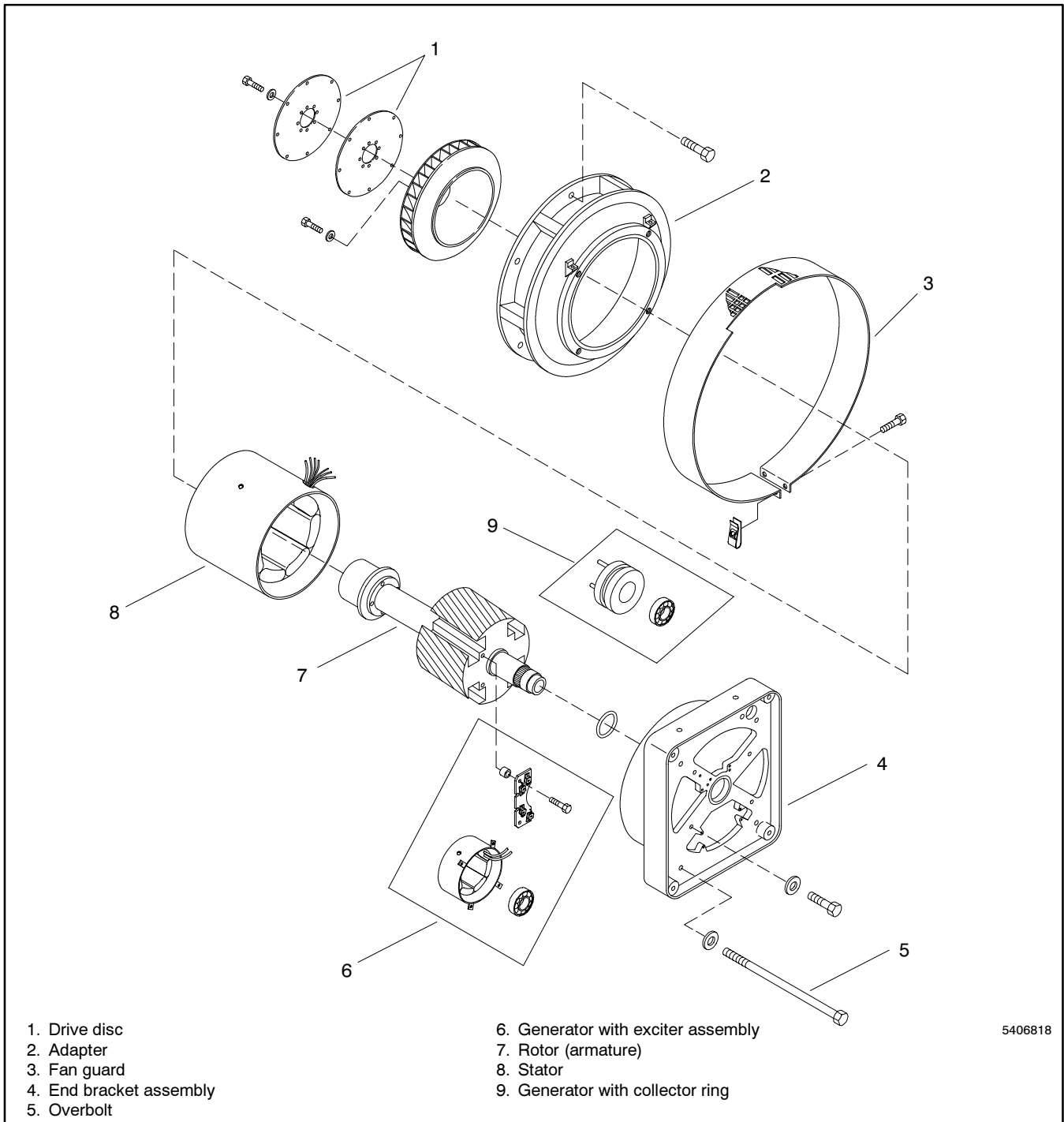

Figure 6-32 End Bracket Assembly, Stator, and Fan Guard Removal

16. Remove three bolts and lock washers securing starter to rear engine mounting plate. Remove starter. Remove remaining screws securing flywheel housing to rear engine mounting plate. Remove flywheel housing. See Figure 6-33.
17. Remove six nuts, washers, and spacers securing drive discs to engine flywheel. Remove rotor.

6.4 Reassembly, 18RY/RFY/RZ/RFZ

1. Secure drive discs and rotor to studs on flywheel with six spacers, washers, and nuts. Tighten to 65 Nm (50 ft. lb.). See Figure 6-33.

2. Position rear engine mounting plate and flywheel housing on rear of engine. Secure with screws and washers.
3. Reconnect starter to rear engine mounting plate with three screws and washers.
4. Attach adapter to flywheel housing with twelve screws. See Figure 6-33.
5. Install fan guard on adapter; secure with two screws.
6. Use a hoist, if necessary, to support stator and gently slide stator over rotor (armature). Be careful to avoid damaging rotor (armature) or stator during removal.

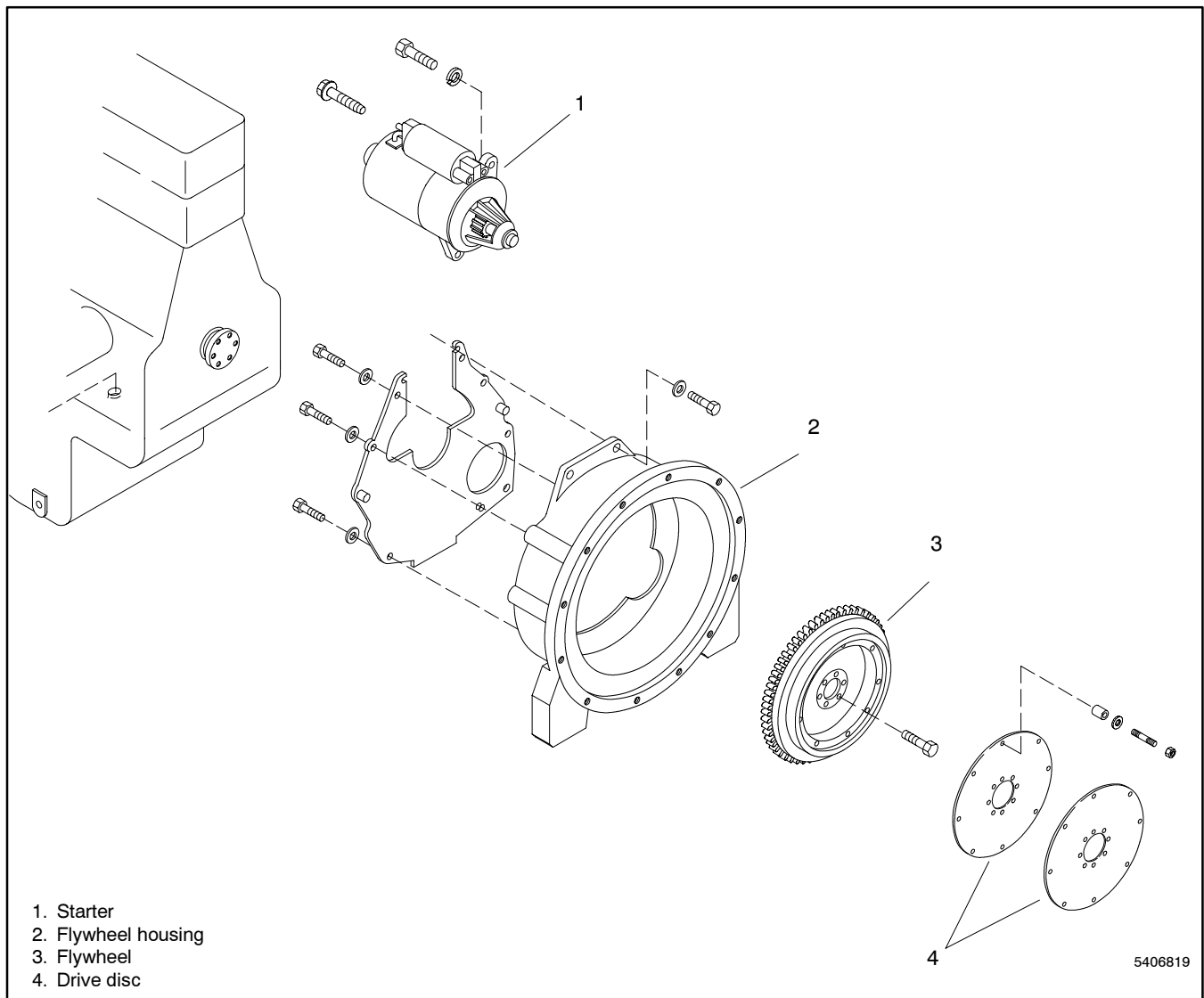

Figure 6-33 Flywheel Housing and Rotor Removal

7. The alternator uses one of three end bracket configurations. If end bracket has a tolerance ring, refer to step a. If end bracket uses a continuous contour and a narrow groove for an O-ring, refer to step b. If end bracket uses a continuous contour with no groove, refer to step c.

Note: Do not apply lubricant to any part during end bracket installation.

- a. **Tolerance ring end bracket:** Route stator leads through port in end bracket while positioning end bracket against stator. Install new tolerance ring in end bracket. Use a mallet, if necessary, to gently tap end bracket into position.

Note: Do NOT attempt to install end bracket on rotor by tightening overbolts. Tightening overbolts may cause damage to end bracket and/or generator adapter.

- b. **End bracket with groove:** Assemble new O-ring into end bracket bearing bore groove. Route stator leads through port in end bracket while positioning end bracket against stator. Align end bracket on stator assembly and rotor bearing. For precise fit, assemble the end bracket and rotor bearing at the same temperature. Check that stator shell notches, if present, are on top and end bracket is aligned. The complete assembly of the generator set requires correct alignment of these components.
- c. **End bracket without groove:** Route stator leads through port in end bracket while positioning end bracket against stator. Align end bracket on stator assembly and rotor bearing. For precise fit, assemble the end bracket and rotor bearing at the same temperature. Check that stator shell notches, if present, are on top and end bracket is aligned. The complete assembly of the generator set requires correct alignment of these components.

8. Use a hard rubber or dead blow hammer to alternately strike end bracket using medium-force blows. Use the rotating sequence shown in Figure 6-34 to install end bracket. With end bracket fully seated in stator assembly, install and tighten overbolts to 24 Nm (216 in. lb.).

Note: Do NOT attempt to install end bracket on rotor by tightening overbolts. Tightening overbolts may cause damage to end bracket and/or generator adapter.

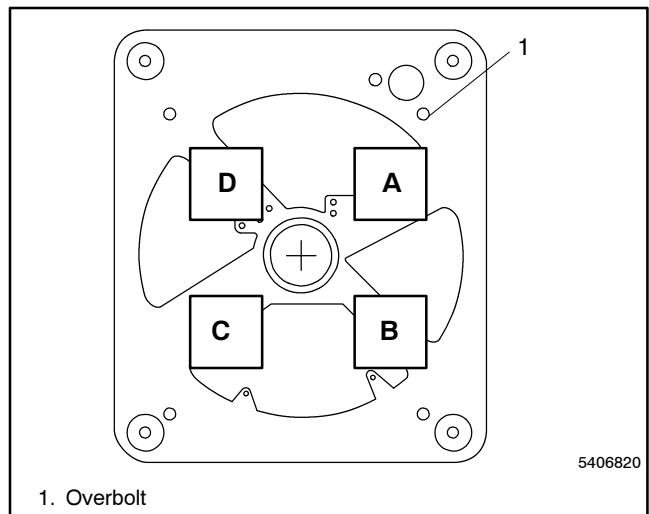

Figure 6-34 End Bracket

9. Remove retainer wire securing brushes in brush holder. Verify that brushes are positioned on rotor slip rings. See Section 5.12, Brushes. Reinstall magnetic pickup on end bracket and secure with two screws and washers. Verify actuator/magnetic pickup air gap of 0.51–1.27 mm (0.020–0.050 in.).
10. Use a hoist attached to generator lifting eye to raise generator high enough to remove support blocks from beneath engine oil pan. Lower generator set onto skid and replace vibromount hardware.
11. Reinstall louver panel on end bracket. Secure with four screws.
12. Reinstall controller/junction box assembly on generator. Secure with four mounting bolts and washers.
13. Reconnect brush and stator leads to connections in junction box and controller. Refer to wiring diagram in Wiring Diagram Manual. Reinstall controller and junction box side covers. Secure with screws.
14. Reconnect exhaust system, load leads, and remote switch, if equipped.
15. Check that the generator set master switch is in the OFF position.
16. Reconnect the generator set engine starting battery, negative (-) lead last. Reconnect battery charger, if equipped.

Notes

Section 7 Generator Reconnection

7.1 Voltage Reconnection

The voltage reconnection procedure explains voltage reconnections only. Adjust the governor and voltage regulator at time of frequency adjustment. See Section 7, Electronic Governor for frequency adjustment.

The following illustrates the reconnection of 4-lead or 12-lead generator sets. In all cases, follow the National Electrical Code (NEC) guidelines.

Reconnect the stator leads of the generator set to change output phase (12-lead models only) or voltage. Refer to the following procedure and the connection schematics. Follow all safety precautions at the front of this manual and in the text while performing this procedure.

Note: Order voltage reconnection decal 246242 from an authorized service distributor/dealer and affix decal to generator set after reconnecting to a voltage different than the nameplate.

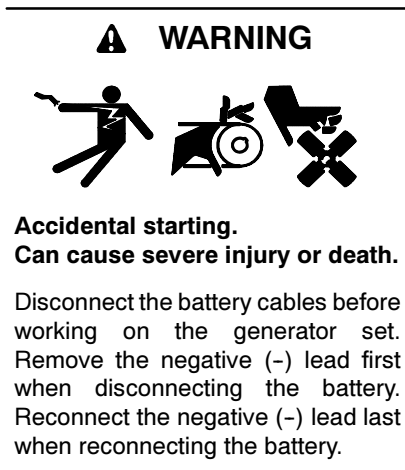

Disabling the generator set. Accidental starting can cause severe injury or death. Before working on the generator set or connected equipment, disable the generator set as follows: (1) Move the generator set master switch to the OFF position. (2) Disconnect the power to the battery charger. (3) Remove the battery cables, negative (-) lead first. Reconnect the negative (-) lead last when reconnecting the battery. Follow these precautions to prevent starting of the generator set by an automatic transfer switch, remote start/stop switch, or engine start command from a remote computer.

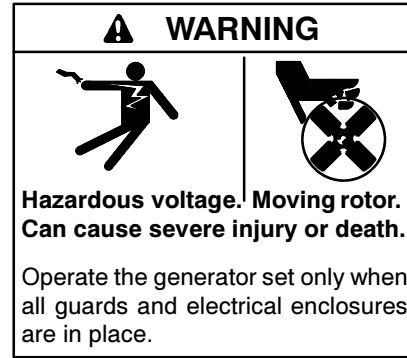

Grounding electrical equipment. Hazardous voltage can cause severe injury or death. Electrocutation is possible whenever electricity is present. Open the main circuit breakers of all power sources before servicing the equipment. Configure the installation to electrically ground the generator set, transfer switch, and related equipment and electrical circuits to comply with applicable codes and standards. Never contact electrical leads or appliances when standing in water or on wet ground because these conditions increase the risk of electrocution.

Short circuits. Hazardous voltage/current can cause severe injury or death. Short circuits can cause bodily injury and/or equipment damage. Do not contact electrical connections with tools or jewelry while making adjustments or repairs. Remove all jewelry before servicing the equipment.

7.1.1 Four-Lead (Single-Phase) Generator Sets

Note: Only generator sets equipped with controllers with meters have current transformers (CTs).

Note: Position current transformers CT1, CT2, and CT3 with dot or HI side toward generator set.

See Figure 7-1 for 4-lead reconnectable (single-phase) generator set options.

	60 Hz	50 Hz
100-120 volt	X	
100-120/200-240 volt	X	X
200-240 volt		X

Figure 7-1 Four-Lead, Single-Phase Generator Set Voltage Connection Options

Note: Microprocessor controller only: Make fine adjustment $\pm 5\%$ using voltage adjustment potentiometer on the controller front panel.

7.1.2 100-120 Volt Configurations

Do not connect the load-side terminals of the circuit breaker together when using a factory two-pole circuit breaker. See Figure 7-3. If the installation requires a 100-120 volt, 2 wire system, use a single-pole circuit breaker. See Figure 7-4. When connecting stator phase leads together, size output lead (L1) according to output. Use a jumper lead on the line side of the circuit breaker to balance the load of the generator set.

	60 Hz	50 Hz
L0-L1	100-120 volt	100-120 volt
L0-L2	100-120 volt	100-120 volt

Figure 7-2 Voltage Range Between Load Leads

7.1.3 100-120/200-240 Volt

Jumper lead not used. If the generator set was originally wired for straight 100-120 volt 3 wire, be sure to remove jumper lead. See Figure 7-6 for location of jumper lead. Leads L1 and L2 are of different phases. Never connect Leads L1 and L2 together.

Note: Use a circuit breaker manufacturer's two-pole circuit breaker. Two single-pole circuit breakers do not conform to NEC requirements when supplying a 200-240 volt load, even if they are mechanically attached together.

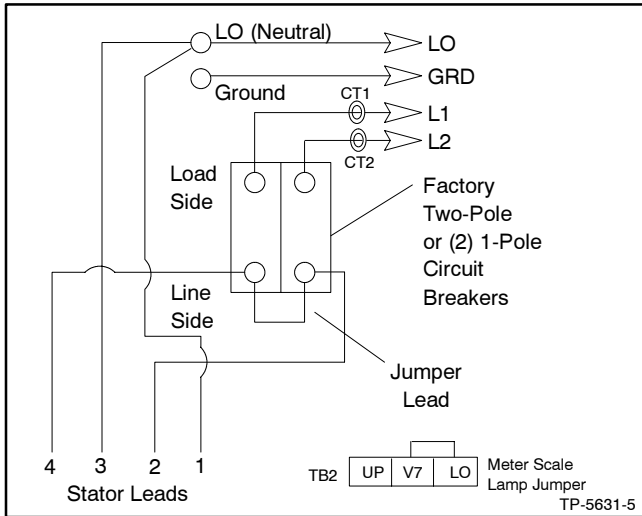

Figure 7-3 100-120 Volt, 3 Wire Configurations

7.1.4 200-240 Volt

Jumper lead not used. If the generator set was originally wired for straight 100-120 volt, 3 wire, be sure to remove jumper lead. See Figure 7-7 for location of jumper lead.

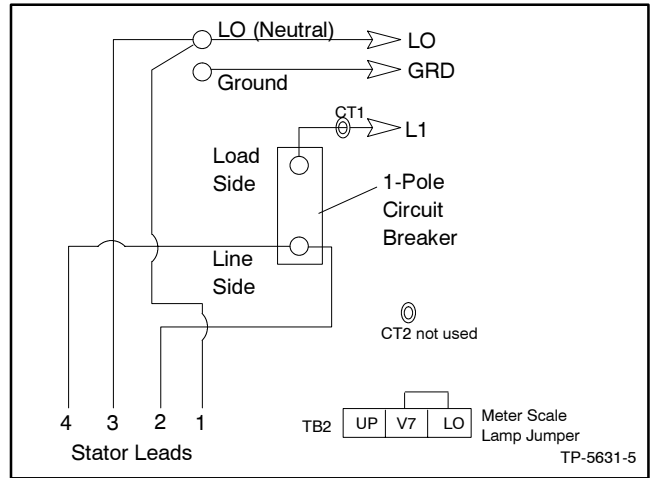

Figure 7-4 100-120 Volt, 2 Wire Configurations

	60 Hz	50 Hz
L0-L1	100-120 volt	100-120 volt
L0-L2	100-120 volt	100-120 volt
L1-L2	200-240 volt	200-240 volt

Figure 7-5 Voltage Range Between Load Leads

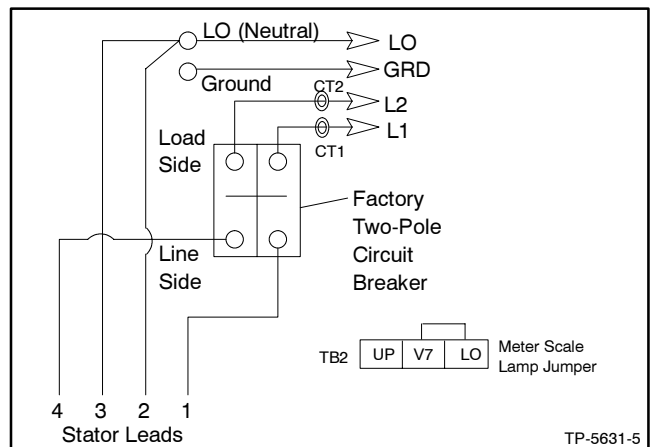

Figure 7-6 100-120/200-240 Volt, 3 Wire Configurations

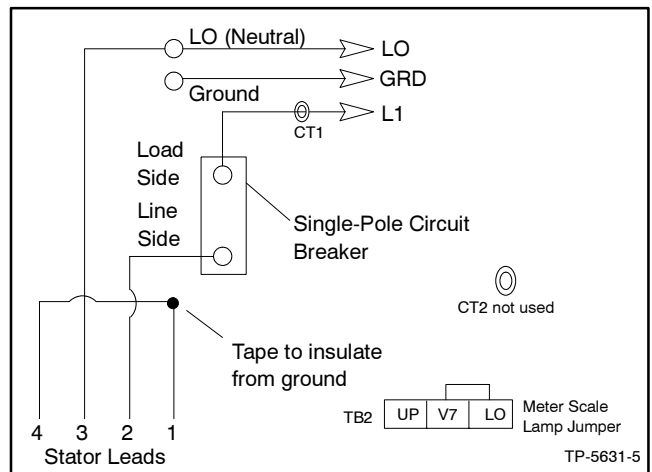

Figure 7-7 200-240 Volt, 2 Wire Configurations

7.1.5 12-Lead (3-Phase) Generator Sets

Note: Only generator sets equipped with controllers with meters have current transformers (CTs).

Note: Position current transformers CT1, CT2, and CT3 with dot or HI side toward generator set.

Reconnect 3-phase, 12-lead generator sets to the voltages and phases shown in Figure 7-8. If reconnecting the generator set obtains a different output voltage, adjust voltage regulator voltage adjustment to obtain desired voltage.

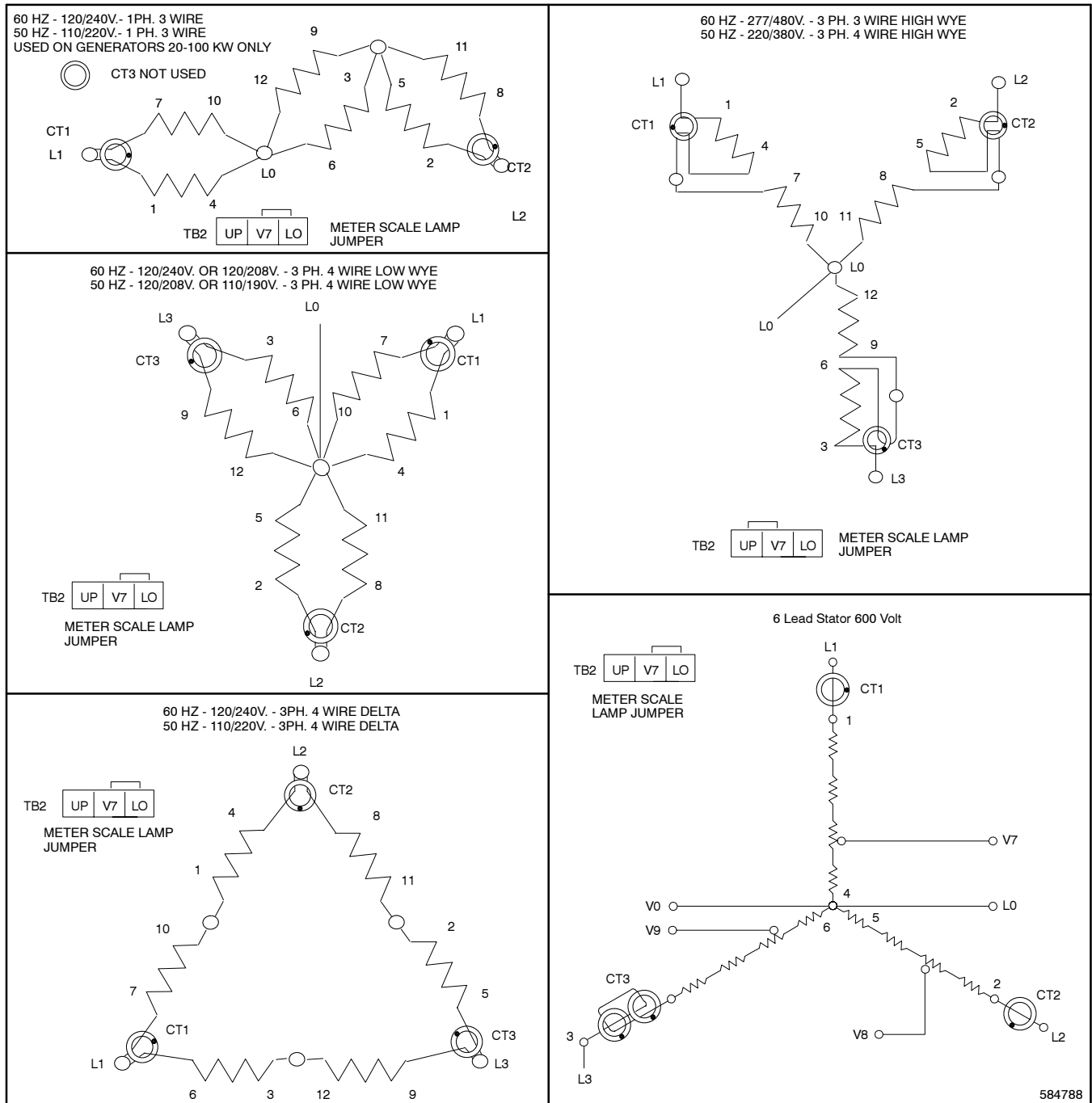

Figure 7-8 Generator Reconnection

584788

7.1.6 Reconnection Procedure (Microprocessor Controller only)

1. Place the generator set master switch in the OFF/RESET position.
2. Disconnect engine starting battery, negative (-) lead first. Disconnect power to battery charger, if equipped.
3. Select desired voltage connection from Figure 7-8. Route leads through current transformers and connect according to the diagram for desired phase and voltage.

Note: Position current transformers CT1 and CT2 (single-phase) or CT1, CT2, and CT3 (3-phase) with dot or HI mark toward generator set. Only generator sets equipped with controllers with meters have current transformers (CTs).

NOTE

Equipment Damage! Verify that transfer switch, line circuit breakers, and any other accessories using line voltage are sized for the voltage selected.

Note: See Section 5.15, Electronic Governor, for frequency adjustment information.

4. If controller has meters, remove controller cover and reposition meter scale lamp jumper to match meter scale lamps with desired voltage. See Figure 7-8.
5. Place the J1 jumper on the overvoltage circuit board if connecting the generator set for 139/240 or 277/480 volts (3-phase, 4-wire, 60 Hz) and if the generator set has the overvoltage kit. See Figure 7-9 for J1 jumper location on the overvoltage circuit board. For all other voltages, remove J1 jumper from the overvoltage circuit board.
6. If the controller has meters, turn the phase selector switch to the L1-L2 position (1-phase or 3-phase depending on generator connection). If the controller does not have meters, connect a voltmeter across leads L1 and L2.
7. Reconnect generator set engine starting battery, negative (-) lead last.
8. Place the generator master switch in the RUN position to start the generator set.
9. Check voltage at voltmeter. Adjust voltage using the voltage adjustment potentiometer on the controller front panel. See Figure 7-11.

10. Stop generator set after adjustment procedure.

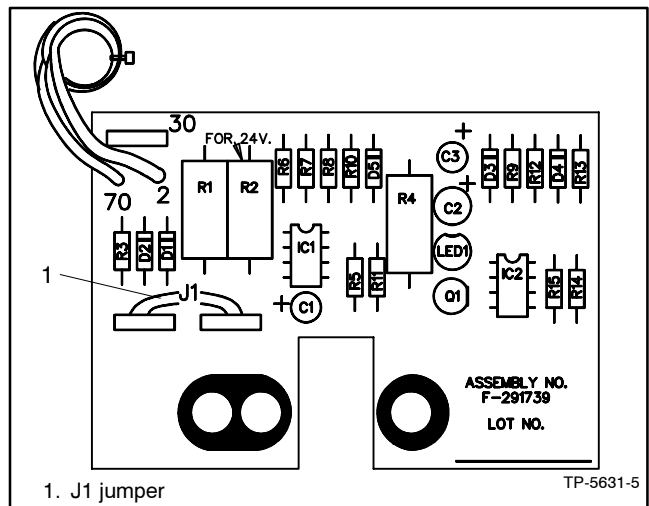

Figure 7-9 Overvoltage Circuit Board

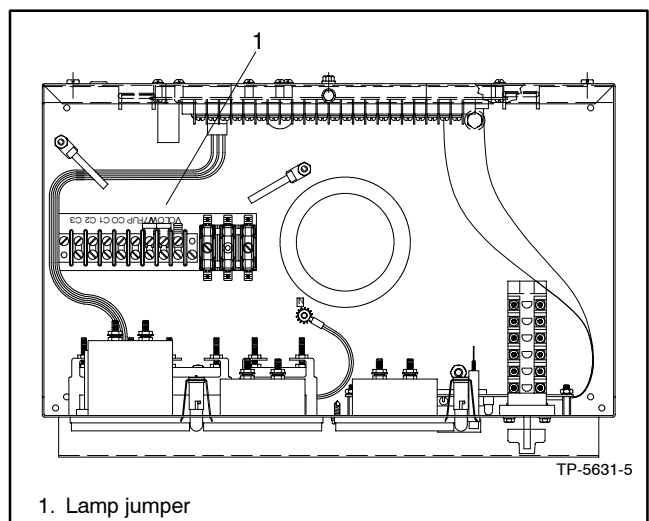

Figure 7-10 Meter Scale Lamp Jumper

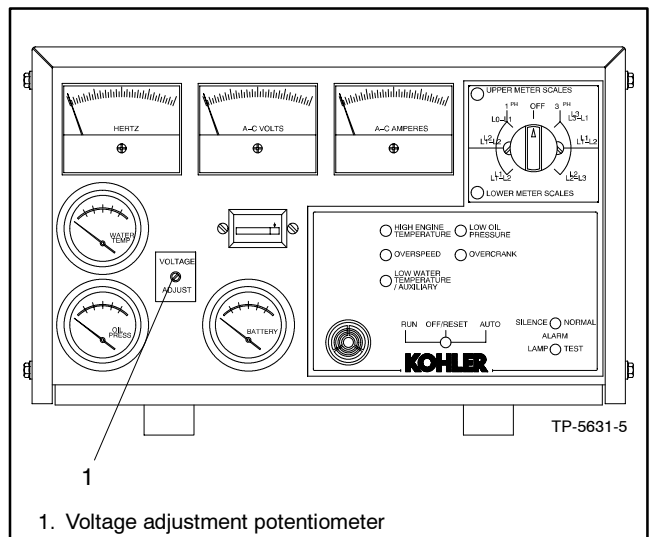

Figure 7-11 Voltage Adjustment (typical)

Appendix A Abbreviations

The following list contains abbreviations that may appear in this publication.

A, amp	ampere	cfm	cubic feet per minute	exh.	exhaust
ABDC	after bottom dead center	CG	center of gravity	ext.	external
AC	alternating current	CID	cubic inch displacement	F	Fahrenheit, female
A/D	analog to digital	CL	centerline	fglass.	fiberglass
ADC	analog to digital converter	cm	centimeter	FHM	flat head machine (screw)
adj.	adjust, adjustment	CMOS	complementary metal oxide substrate (semiconductor)	fl. oz.	fluid ounce
ADV	advertising dimensional drawing	cogen.	cogeneration	flex.	flexible
AHWT	anticipatory high water temperature	com	communications (port)	freq.	frequency
AISI	American Iron and Steel Institute	coml	commercial	FS	full scale
ALOP	anticipatory low oil pressure	Coml/Rec	Commercial/Recreational	ft.	foot, feet
alt.	alternator	conn.	connection	ft. lbs.	foot pounds (torque)
Al	aluminum	cont.	continued	ft./min.	feet per minute
ANSI	American National Standards Institute (formerly American Standards Association, ASA)	CPVC	chlorinated polyvinyl chloride	g	gram
AO	anticipatory only	crit.	critical	ga.	gauge (meters, wire size)
API	American Petroleum Institute	CRT	cathode ray tube	gal.	gallon
approx.	approximate, approximately	CSA	Canadian Standards Association	gen.	generator
AR	as required, as requested	CT	current transformer	genset	generator set
AS	as supplied, as stated, as suggested	Cu	copper	GFI	ground fault interrupter
ASE	American Society of Engineers	cu. in.	cubic inch	GND, 	ground
ASME	American Society of Mechanical Engineers	cw.	clockwise	gov.	governor
assy.	assembly	CWC	city water-cooled	gph	gallons per hour
ASTM	American Society for Testing Materials	cyl.	cylinder	gpm	gallons per minute
ATDC	after top dead center	D/A	digital to analog	gr.	grade, gross
ATS	automatic transfer switch	DAC	digital to analog converter	GRD	equipment ground
auto.	automatic	dB	decibel	gr. wt.	gross weight
aux.	auxiliary	dBA	decibel (A weighted)	H x W x D	height by width by depth
A/V	audiovisual	DC	direct current	HC	hex cap
avg.	average	DCR	direct current resistance	HCHT	high cylinder head temperature
AVR	automatic voltage regulator	deg., °	degree	HD	heavy duty
AWG	American Wire Gauge	dept.	department	HET	high exhaust temperature, high engine temperature
AWM	appliance wiring material	dia.	diameter	hex	hexagon
bat.	battery	DI/EO	dual inlet/end outlet	Hg	mercury (element)
BBDC	before bottom dead center	DIN	Deutsches Institut fur Normung e. V. (also Deutsche Industrie Normenausschuss)	HH	hex head
BC	battery charger, battery charging	DIP	dual inline package	HHC	hex head cap
BCA	battery charging alternator	DPDT	double-pole, double-throw	HP	horsepower
BCI	Battery Council International	DPST	double-pole, single-throw	hr.	hour
BDC	before dead center	DS	disconnect switch	HS	heat shrink
BHP	brake horsepower	DVR	digital voltage regulator	hsg.	housing
blk.	black (paint color), block (engine)	E, emer.	emergency (power source)	HVAC	heating, ventilation, and air conditioning
blk. htr.	block heater	EDI	electronic data interchange	HWT	high water temperature
BMEP	brake mean effective pressure	EFR	emergency frequency relay	Hz	hertz (cycles per second)
bps	bits per second	e.g.	for example (<i>exempli gratia</i>)	IC	integrated circuit
br.	brass	EG	electronic governor	ID	inside diameter, identification
BTDC	before top dead center	EGSA	Electrical Generating Systems Association	IEC	International Electrotechnical Commission
Btu	British thermal unit	EIA	Electronic Industries Association	IEEE	Institute of Electrical and Electronics Engineers
Btu/min.	British thermal units per minute	EI/EO	end inlet/end outlet	IMS	improved motor starting
C	Celsius, centigrade	EMI	electromagnetic interference	in.	inch
cal.	calorie	emiss.	emission	in. H ₂ O	inches of water
CARB	California Air Resources Board	eng.	engine	in. Hg	inches of mercury
CB	circuit breaker	EPA	Environmental Protection Agency	in. lbs.	inch pounds
cc	cubic centimeter	EPS	emergency power system	Inc.	incorporated
CCA	cold cranking amps	ER	emergency relay	ind.	industrial
ccw.	counterclockwise	ES	engineering special, engineered special	int.	internal
CEC	Canadian Electrical Code	ESD	electrostatic discharge	int./ext.	internal/external
cert.	certificate, certification, certified	est.	estimated	I/O	input/output
cfh	cubic feet per hour	E-Stop	emergency stop	IP	iron pipe
		etc.	et cetera (and so forth)	ISO	International Organization for Standardization
				J	joule
				JIS	Japanese Industry Standard

k	kilo (1000)	MTBF	mean time between failure	RHM	round head machine (screw)
K	kelvin	MTBO	mean time between overhauls	rly.	relay
kA	kiloampere	mtg.	mounting	rms	root mean square
KB	kilobyte (2 ¹⁰ bytes)	MW	megawatt	rnd.	round
kg	kilogram	mW	milliwatt	ROM	read only memory
kg/cm ²	kilograms per square centimeter	μF	microfarad	rot.	rotate, rotating
kgm	kilogram-meter	N, norm.	normal (power source)	rpm	revolutions per minute
kg/m ³	kilograms per cubic meter	NA	not available, not applicable	RS	right side
kHz	kilohertz	nat. gas	natural gas	RTV	room temperature vulcanization
kJ	kilojoule	NBS	National Bureau of Standards	SAE	Society of Automotive Engineers
km	kilometer	NC	normally closed	scfm	standard cubic feet per minute
kOhm, kΩ	kilo-ohm	NEC	National Electrical Code	SCR	silicon controlled rectifier
kPa	kilopascal	NEMA	National Electrical Manufacturers Association	s, sec.	second
kph	kilometers per hour	NFPA	National Fire Protection Association	SI	<i>Système international d'unités</i> , International System of Units
kV	kilovolt	Nm	newton meter	SI/EO	side in/end out
kVA	kilovolt ampere	NO	normally open	sil.	silencer
kVAR	kilovolt ampere reactive	no., nos.	number, numbers	SN	serial number
kW	kilowatt	NPS	National Pipe, Straight	SPDT	single-pole, double-throw
kWh	kilowatt-hour	NPSC	National Pipe, Straight-coupling	SPST	single-pole, single-throw
kWm	kilowatt mechanical	NPT	National Standard taper pipe thread per general use	spec, specs	specification(s)
L	liter	NPTF	National Pipe, Taper-Fine	sq.	square
LAN	local area network	NR	not required, normal relay	sq. cm	square centimeter
L x W x H	length by width by height	ns	nanosecond	sq. in.	square inch
lb.	pound, pounds	OC	overcrank	SS	stainless steel
lbm/ft ³	pounds mass per cubic feet	OD	outside diameter	std.	standard
LCB	line circuit breaker	OEM	original equipment manufacturer	stl.	steel
LCD	liquid crystal display	OF	overfrequency	tach.	tachometer
ld. shd.	load shed	opt.	option, optional	TD	time delay
LED	light emitting diode	OS	oversize, overspeed	TDC	top dead center
Lph	liters per hour	OSHA	Occupational Safety and Health Administration	TDEC	time delay engine cooldown
Lpm	liters per minute	OV	overvoltage	TDEN	time delay emergency to normal
LOP	low oil pressure	oz.	ounce	TDES	time delay engine start
LP	liquefied petroleum	p., pp.	page, pages	TDNE	time delay normal to emergency
LPG	liquefied petroleum gas	PC	personal computer	TDOE	time delay off to emergency
LS	left side	PCB	printed circuit board	TDON	time delay off to normal
L _{wa}	sound power level, A weighted	pF	picofarad	temp.	temperature
LWL	low water level	PF	power factor	term.	terminal
LWT	low water temperature	ph., ∅	phase	TIF	telephone influence factor
m	meter, milli (1/1000)	PHC	Phillips head crimplite (screw)	TIR	total indicator reading
M	mega (10 ⁶ when used with SI units), male	PHH	Phillips hex head (screw)	tol.	tolerance
m ³	cubic meter	PHM	pan head machine (screw)	turbo.	turbocharger
m ³ /min.	cubic meters per minute	PLC	programmable logic control	typ.	typical (same in multiple locations)
mA	milliampere	PMG	permanent-magnet generator	UF	underfrequency
man.	manual	pot	potentiometer, potential	UHF	ultrahigh frequency
max.	maximum	ppm	parts per million	UL	Underwriter's Laboratories, Inc.
MB	megabyte (2 ²⁰ bytes)	PROM	programmable read-only memory	UNC	unified coarse thread (was NC)
MCM	one thousand circular mils	psi	pounds per square inch	UNF	unified fine thread (was NF)
MCCB	molded-case circuit breaker	pt.	pint	univ.	universal
meggar	megohmmeter	PTC	positive temperature coefficient	US	undersize, underspeed
MHz	megahertz	PTO	power takeoff	UV	ultraviolet, undervoltage
mi.	mile	PVC	polyvinyl chloride	V	volt
mil	one one-thousandth of an inch	qt.	quart, quarts	VAC	volts alternating current
min.	minimum, minute	qty.	quantity	VAR	voltampere reactive
misc.	miscellaneous	R	replacement (emergency) power source	VDC	volts direct current
MJ	megajoule	rad.	radiator, radius	VFD	vacuum fluorescent display
mJ	millijoule	RAM	random access memory	VGA	video graphics adapter
mm	millimeter	RDO	relay driver output	VHF	very high frequency
mOhm, mΩ	milliohm	ref.	reference	W	watt
MOhm, MΩ	megohm	rem.	remote	WCR	withstand and closing rating
MOV	metal oxide varistor	Res/Coml	Residential/Commercial	w/	with
MPa	megapascal	RFI	radio frequency interference	w/o	without
mpg	miles per gallon	RH	round head	wt.	weight
mph	miles per hour			xfmr	transformer
MS	military standard				
m/sec.	meters per second				

Appendix B Common Hardware Application Guidelines

Use the information below and on the following pages to identify proper fastening techniques when no specific reference for reassembly is made.

Bolt/Screw Length: When bolt/screw length is not given, use Figure 1 as a guide. As a general rule, a minimum length of one thread beyond the nut and a maximum length of 1/2 the bolt/screw diameter beyond the nut is the preferred method.

Washers and Nuts: Use split lock washers as a bolt locking device where specified. Use SAE flat washers with whiz nuts, spirallock nuts, or standard nuts and preloading (torque) of the bolt in all other applications.

See Appendix C, General Torque Specifications, and other torque specifications in the service literature.

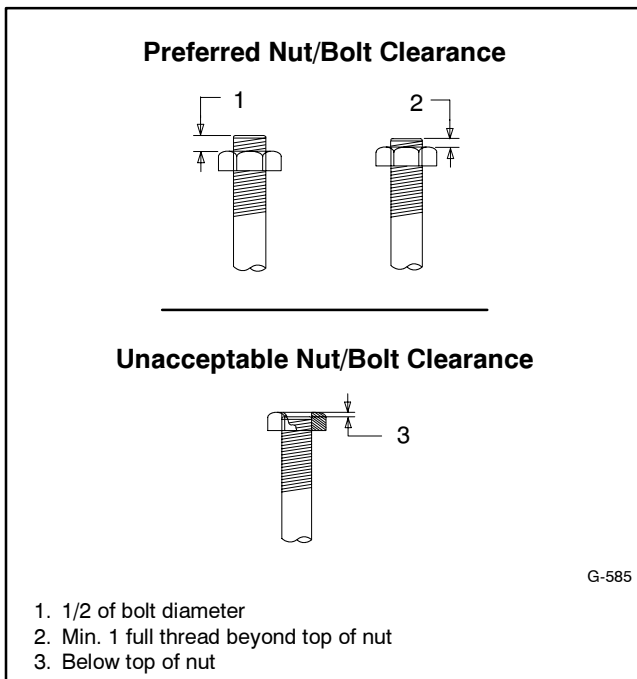

Figure 1 Acceptable Bolt Lengths

Steps for common hardware application:

1. Determine entry hole type: round or slotted.
2. Determine exit hole type: fixed female thread (weld nut), round, or slotted.

For round and slotted exit holes, determine if hardware is greater than 1/2 inch in diameter, or 1/2 inch in diameter or less. Hardware that is *greater than 1/2 inch* in diameter takes a standard nut and SAE washer. Hardware *1/2 inch or less* in diameter can take a properly torqued whiz nut or spirallock nut. See Figure 2.

3. Follow these SAE washer rules after determining exit hole type:
 - a. Always use a washer between hardware and a slot.
 - b. Always use a washer under a nut (see 2 above for exception).
 - c. Use a washer under a bolt when the female thread is fixed (weld nut).
4. Refer to Figure 2, which depicts the preceding hardware configuration possibilities.

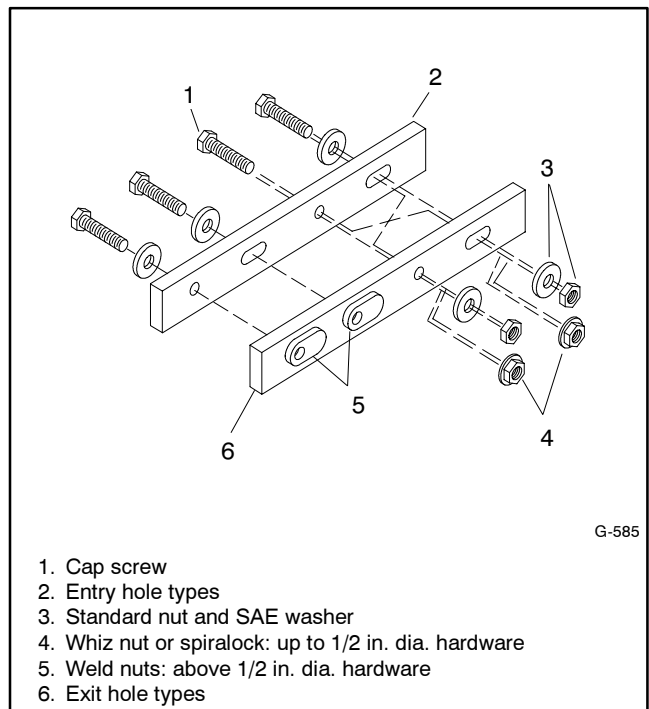

Figure 2 Acceptable Hardware Combinations

Appendix C General Torque Specifications















Use the following torque specifications when service literature instructions give no specific torque values. The charts list values for new plated, zinc phosphate, or











oiled threads. Increase values by 15% for nonplated threads. All torque values are +0%/-10%.





American Standard Fasteners Torque Specifications					
Size	Torque Measurement	Assembled into Cast Iron or Steel			Assembled into Aluminum Grade 2 or 5
		Grade 2	Grade 5	Grade 8	
8-32	Nm (in. lb.)	1.8 (16)	2.3 (20)	—	1.8 (16)
10-24	Nm (in. lb.)	2.9 (26)	3.6 (32)	—	2.9 (26)
10-32	Nm (in. lb.)	2.9 (26)	3.6 (32)	—	2.9 (26)
1/4-20	Nm (in. lb.)	6.8 (60)	10.8 (96)	14.9 (132)	6.8 (60)
1/4-28	Nm (in. lb.)	8.1 (72)	12.2 (108)	16.3 (144)	8.1 (72)
5/16-18	Nm (in. lb.)	13.6 (120)	21.7 (192)	29.8 (264)	13.6 (120)
5/16-24	Nm (in. lb.)	14.9 (132)	23.1 (204)	32.5 (288)	14.9 (132)
3/8-16	Nm (ft. lb.)	24.0 (18)	38.0 (28)	53.0 (39)	24.0 (18)
3/8-24	Nm (ft. lb.)	27.0 (20)	42.0 (31)	60.0 (44)	27.0 (20)
7/16-14	Nm (ft. lb.)	39.0 (29)	60.0 (44)	85.0 (63)	—
7/16-20	Nm (ft. lb.)	43.0 (32)	68.0 (50)	95.0 (70)	—
1/2-13	Nm (ft. lb.)	60.0 (44)	92.0 (68)	130.0 (96)	—
1/2-20	Nm (ft. lb.)	66.0 (49)	103.0 (76)	146.0 (108)	—
9/16-12	Nm (ft. lb.)	81.0 (60)	133.0 (98)	187.0 (138)	—
9/16-18	Nm (ft. lb.)	91.0 (67)	148.0 (109)	209.0 (154)	—
5/8-11	Nm (ft. lb.)	113.0 (83)	183.0 (135)	259.0 (191)	—
5/8-18	Nm (ft. lb.)	128.0 (94)	208.0 (153)	293.0 (216)	—
3/4-10	Nm (ft. lb.)	199.0 (147)	325.0 (240)	458.0 (338)	—
3/4-16	Nm (ft. lb.)	222.0 (164)	363.0 (268)	513.0 (378)	—
1-8	Nm (ft. lb.)	259.0 (191)	721.0 (532)	1109.0 (818)	—
1-12	Nm (ft. lb.)	283.0 (209)	789.0 (582)	1214.0 (895)	—

Metric Fasteners Torque Specifications, Measured in Nm (ft. lb.)					
Size (mm)	Assembled into Cast Iron or Steel			Assembled into Aluminum Grade 5.8 or 8.8	
	Grade 5.8	Grade 8.8	Grade 10.9		
M6 x 1.00	5.6 (4)	9.9 (7)	14.0 (10)	5.6 (4)	
M8 x 1.25	13.6 (10)	25.0 (18)	35.0 (26)	13.6 (10)	
M8 x 1.00	21.0 (16)	25.0 (18)	35.0 (26)	21.0 (16)	
M10 x 1.50	27.0 (20)	49.0 (35)	68.0 (50)	27.0 (20)	
M10 x 1.25	39.0 (29)	49.0 (35)	68.0 (50)	39.0 (29)	
M12 x 1.75	47.0 (35)	83.0 (61)	117.0 (86)	—	
M12 x 1.50	65.0 (48)	88.0 (65)	125.0 (92)	—	
M14 x 2.00	74.0 (55)	132.0 (97)	185.0 (136)	—	
M14 x 1.50	100.0 (74)	140.0 (103)	192.0 (142)	—	
M16 x 2.00	115.0 (85)	200.0 (148)	285.0 (210)	—	
M16 x 1.50	141.0 (104)	210.0 (155)	295.0 (218)	—	
M18 x 2.50	155.0 (114)	275.0 (203)	390.0 (288)	—	
M18 x 1.50	196.0 (145)	305.0 (225)	425.0 (315)	—	

Appendix D Common Hardware Identification

Screw/Bolts/Studs	
Head Styles	
Hex Head or Machine Head	
Hex Head or Machine Head with Washer	
Flat Head (FHM)	
Round Head (RHM)	
Pan Head	
Hex Socket Head Cap or Allen™ Head Cap	
Hex Socket Head or Allen™ Head Shoulder Bolt	
Sheet Metal Screw	
Stud	
Drive Styles	
Hex	
Hex and Slotted	
Phillips®	
Slotted	
Hex Socket	

Nuts	
Nut Styles	
Hex Head	
Lock or Elastic	
Square	
Cap or Acorn	
Wing	
Washers	
Washer Styles	
Plain	
Split Lock or Spring	
Spring or Wave	
External Tooth Lock	
Internal Tooth Lock	
Internal-External Tooth Lock	

Hardness Grades	
American Standard	
Grade 2	
Grade 5	
Grade 8	
Grade 8/9 (Hex Socket Head)	
Metric	
Number stamped on hardware; 5.8 shown	

Allen™ head screw is a trademark of Holo-Krome Co.

Phillips® screw is a registered trademark of Phillips Screw Company.

Sample Dimensions

American Standard (Screws, Bolts, Studs, and Nuts)

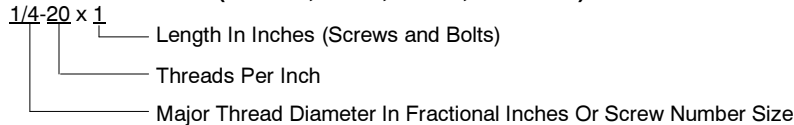

Metric (Screws, Bolts, Studs, and Nuts)

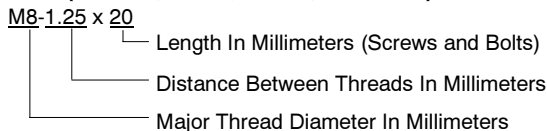

Plain Washers

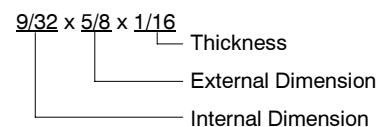

Lock Washers



Appendix E Common Hardware List

The Common Hardware List lists part numbers and dimensions for common hardware items.

American Standard

Part No. Dimensions Hex Head Bolts (Grade 5)

X-465-17	1/4-20 x .38
X-465-6	1/4-20 x .50
X-465-2	1/4-20 x .62
X-465-16	1/4-20 x .75
X-465-18	1/4-20 x .88
X-465-7	1/4-20 x 1.00
X-465-8	1/4-20 x 1.25
X-465-9	1/4-20 x 1.50
X-465-10	1/4-20 x 1.75
X-465-11	1/4-20 x 2.00
X-465-12	1/4-20 x 2.25
X-465-14	1/4-20 x 2.75
X-465-21	1/4-20 x 5.00
X-465-25	1/4-28 x .38
X-465-20	1/4-28 x 1.00
X-125-33	5/16-18 x .50
X-125-23	5/16-18 x .62
X-125-3	5/16-18 x .75
X-125-31	5/16-18 x .88
X-125-5	5/16-18 x 1.00
X-125-24	5/16-18 x 1.25
X-125-34	5/16-18 x 1.50
X-125-25	5/16-18 x 1.75
X-125-26	5/16-18 x 2.00
230578	5/16-18 x 2.25
X-125-29	5/16-18 x 2.50
X-125-27	5/16-18 x 2.75
X-125-28	5/16-18 x 3.00
X-125-22	5/16-18 x 4.50
X-125-32	5/16-18 x 5.00
X-125-35	5/16-18 x 5.50
X-125-36	5/16-18 x 6.00
X-125-40	5/16-18 x 6.50
X-125-43	5/16-24 x 1.75
X-125-44	5/16-24 x 2.50
X-125-30	5/16-24 x .75
X-125-39	5/16-24 x 2.00
X-125-38	5/16-24 x 2.75
X-6238-2	3/8-16 x .62
X-6238-10	3/8-16 x .75
X-6238-3	3/8-16 x .88
X-6238-11	3/8-16 x 1.00
X-6238-4	3/8-16 x 1.25
X-6238-5	3/8-16 x 1.50
X-6238-1	3/8-16 x 1.75
X-6238-6	3/8-16 x 2.00
X-6238-17	3/8-16 x 2.25
X-6238-7	3/8-16 x 2.50
X-6238-8	3/8-16 x 2.75
X-6238-9	3/8-16 x 3.00
X-6238-19	3/8-16 x 3.25
X-6238-12	3/8-16 x 3.50
X-6238-20	3/8-16 x 3.75
X-6238-13	3/8-16 x 4.50
X-6238-18	3/8-16 x 5.50
X-6238-25	3/8-16 x 6.50

Part No. Dimensions Hex Head Bolts, cont.

X-6238-14	3/8-24 x .75
X-6238-16	3/8-24 x 1.25
X-6238-21	3/8-24 x 4.00
X-6238-22	3/8-24 x 4.50
X-6024-5	7/16-14 x .75
X-6024-2	7/16-14 x 1.00
X-6024-8	7/16-14 x 1.25
X-6024-3	7/16-14 x 1.50
X-6024-4	7/16-14 x 2.00
X-6024-11	7/16-14 x 2.75
X-6024-12	7/16-14 x 6.50
X-129-15	1/2-13 x .75
X-129-17	1/2-13 x 1.00
X-129-18	1/2-13 x 1.25
X-129-19	1/2-13 x 1.50
X-129-20	1/2-13 x 1.75
X-129-21	1/2-13 x 2.00
X-129-22	1/2-13 x 2.25
X-129-23	1/2-13 x 2.50
X-129-24	1/2-13 x 2.75
X-129-25	1/2-13 x 3.00
X-129-27	1/2-13 x 3.50
X-129-29	1/2-13 x 4.00
X-129-30	1/2-13 x 4.50
X-463-9	1/2-13 x 5.50
X-129-44	1/2-13 x 6.00
X-129-51	1/2-20 x .75
X-129-45	1/2-20 x 1.25
X-129-52	1/2-20 x 1.50
X-6021-3	5/8-11 x 1.00
X-6021-4	5/8-11 x 1.25
X-6021-2	5/8-11 x 1.50
X-6021-1	5/8-11 x 1.75
273049	5/8-11 x 2.00
X-6021-5	5/8-11 x 2.25
X-6021-6	5/8-11 x 2.50
X-6021-7	5/8-11 x 2.75
X-6021-12	5/8-11 x 3.75
X-6021-11	5/8-11 x 4.50
X-6021-10	5/8-11 x 6.00
X-6021-9	5/8-18 x 2.50
X-6239-1	3/4-10 x 1.00
X-6239-8	3/4-10 x 1.25
X-6239-2	3/4-10 x 1.50
X-6239-3	3/4-10 x 2.00
X-6239-4	3/4-10 x 2.50
X-6239-5	3/4-10 x 3.00
X-6239-6	3/4-10 x 3.50
X-792-1	1-8 x 2.25
X-792-5	1-8 x 3.00
X-792-8	1-8 x 5.00

Part No. Dimensions Type

Hex Nuts

X-6009-1	1-8	Standard
X-6210-3	6-32	Whiz
X-6210-4	8-32	Whiz
X-6210-5	10-24	Whiz
X-6210-1	10-32	Whiz
X-6210-2	1/4-20	Spiralock
X-6210-6	1/4-28	Spiralock
X-6210-7	5/16-18	Spiralock
X-6210-8	5/16-24	Spiralock
X-6210-9	3/8-16	Spiralock
X-6210-10	3/8-24	Spiralock
X-6210-11	7/16-14	Spiralock
X-6210-12	1/2-13	Spiralock
X-6210-15	7/16-20	Spiralock
X-6210-14	1/2-20	Spiralock
X-85-3	5/8-11	Standard
X-88-12	3/4-10	Standard
X-89-2	1/2-20	Standard

Washers

Part No.	ID	OD	Thick.	Bolt/ Screw
X-25-46	.125	.250	.022	#4
X-25-9	.156	.375	.049	#6
X-25-48	.188	.438	.049	#8
X-25-36	.219	.500	.049	#10
X-25-40	.281	.625	.065	1/4
X-25-85	.344	.687	.065	5/16
X-25-37	.406	.812	.065	3/8
X-25-34	.469	.922	.065	7/16
X-25-26	.531	1.062	.095	1/2
X-25-15	.656	1.312	.095	5/8
X-25-29	.812	1.469	.134	3/4
X-25-127	1.062	2.000	.134	1

Metric

Hex head bolts are hardness grade 8.8 unless noted.

Part No.	Dimensions	Part No.	Dimensions	Part No.	Dimensions
Hex Head Bolts (Partial Thread)					
M931-05055-60	M5-0.80 x 55	Hex Head Bolts (Partial Thread), continued		Hex Head Bolts (Full Thread), continued	
M931-06040-60	M6-1.00 x 40	M960-16090-60	M16-1.50 x 90	M961-14025-60	M14-1.50 x 25
M931-06055-60	M6-1.00 x 55	M931-16090-60	M16-2.00 x 90	M933-14025-60	M14-2.00 x 25
M931-06060-60	M6-1.00 x 60	M931-16100-60	M16-2.00 x 100	M961-14050-82	M14-1.50 x 50
M931-06060-SS	M6-1.00 x 60	M931-16120-60	M16-2.00 x 120	M961-16025-60	M16-1.50 x 25
M931-06070-60	M6-1.00 x 70	M931-16150-60	M16-2.00 x 150	M933-16025-60	M16-2.00 x 25
M931-06070-SS	M6-1.00 x 70	M931-20065-60	M20-2.50 x 65	M961-16030-82	M16-1.50 x 30*
M931-06075-60	M6-1.00 x 75	M931-20100-60	M20-2.50 x 100	M933-16030-82	M16-2.00 x 30*
M931-06090-60	M6-1.00 x 90	M931-20120-60	M20-2.50 x 120	M933-16035-60	M16-2.00 x 35
M931-06145-60	M6-1.00 x 145	M931-20140-60	M20-2.50 x 140	M961-16040-60	M16-1.50 x 40
M931-06150-60	M6-1.00 x 150	M931-20160-60	M20-2.50 x 160	M933-16040-60	M16-2.00 x 40
M931-08035-60	M8-1.25 x 35	M931-22090-60	M22-2.50 x 90	M961-16045-82	M16-1.50 x 45
M931-08040-60	M8-1.25 x 40	M931-22120-60	M22-2.50 x 120	M933-16045-82	M16-2.00 x 45
M931-08040-82	M8-1.25 x 40*	M931-22160-60	M22-2.50 x 160	M933-16050-60	M16-2.00 x 50
M931-08045-60	M8-1.25 x 45	M931-24090-60	M24-3.00 x 90	M933-16050-82	M16-2.00 x 50*
M931-08050-60	M8-1.25 x 50	M931-24120-60	M24-3.00 x 120	M933-16060-60	M16-2.00 x 60
M931-08055-60	M8-1.25 x 55	M931-24160-60	M24-3.00 x 160	M933-16070-60	M16-2.00 x 70
M931-08055-82	M8-1.25 x 55*	Hex Head Bolts (Full Thread)			
M931-08060-60	M8-1.25 x 60	M933-04006-60	M4-0.70 x 6	M933-18035-60	M18-2.50 x 35
M931-08070-60	M8-1.25 x 70	M933-05030-60	M5-0.80 x 30	M933-18050-60	M18-2.50 x 50
M931-08070-82	M8-1.25 x 70*	M933-05035-60	M5-0.80 x 35	M933-18060-60	M18-2.50 x 60
M931-08075-60	M8-1.25 x 75	M933-05050-60	M5-0.80 x 50	M933-20050-60	M20-2.50 x 50
M931-08080-60	M8-1.25 x 80	M933-06010-60	M6-1.00 x 10	M933-20055-60	M20-2.50 x 55
M931-08090-60	M8-1.25 x 90	M933-06012-60	M6-1.00 x 12	M933-24060-60	M24-3.00 x 60
M931-08095-60	M8-1.25 x 95	M933-06014-60	M6-1.00 x 14	M933-24065-60	M24-3.00 x 65
M931-08100-60	M8-1.25 x 100	M933-06016-60	M6-1.00 x 16	M933-24070-60	M24-3.00 x 70
M931-08110-60	M8-1.25 x 110	M933-06020-60	M6-1.00 x 20	Pan Head Machine Screws	
M931-08120-60	M8-1.25 x 120	M933-06025-60	M6-1.00 x 25	M7985A-03010-20	M3-0.50 x 10
M931-08130-60	M8-1.25 x 130	M933-06040-60	M6-1.00 x 40	M7985A-03012-20	M3-0.50 x 12
M931-08140-60	M8-1.25 x 140	M933-06050-60	M6-1.00 x 50	M7985A-04010-20	M4-0.70 x 10
M931-08150-60	M8-1.25 x 150	M933-07025-60	M7-1.00 x 25	M7985A-04016-20	M4-0.70 x 16
M931-10040-82	M10-1.25 x 40*	M933-08010-60	M8-1.25 x 10	M7985A-04020-20	M4-0.70 x 20
M931-10040-60	M10-1.50 x 40	M933-08012-60	M8-1.25 x 12	M7985A-04050-20	M4-0.70 x 50
M931-10045-60	M10-1.50 x 45	M933-08016-60	M8-1.25 x 16	M7985A-04100-20	M4-0.70 x 100
M931-10050-60	M10-1.50 x 50	M933-08020-60	M8-1.25 x 20	M7985A-05010-20	M5-0.80 x 10
M931-10050-82	M10-1.25 x 50	M933-08025-60	M8-1.25 x 25	M7985A-05012-20	M5-0.80 x 12
M931-10055-60	M10-1.50 x 55	M933-08030-60	M8-1.25 x 30	M7985A-05016-20	M5-0.80 x 16
M931-10060-60	M10-1.50 x 60	M933-08030-82	M8-1.25 x 30*	M7985A-05020-20	M5-0.80 x 20
M931-10065-60	M10-1.50 x 65	M933-10012-60	M10-1.50 x 12	M7985A-05025-20	M5-0.80 x 25
M931-10070-60	M10-1.50 x 70	M961-10020-60	M10-1.25 x 20	M7985A-05030-20	M5-0.80 x 30
M931-10080-60	M10-1.50 x 80	M933-10020-60	M10-1.50 x 20	M7985A-05080-20	M5-0.80 x 80
M931-10080-82	M10-1.25 x 80	M933-10025-60	M10-1.50 x 25	M7985A-05100-20	M5-0.80 x 100
M931-10090-60	M10-1.50 x 90	M961-10025-60	M10-1.25 x 25	M7985A-06100-20	M6-1.00 x 100
M931-10090-82	M10-1.50 x 90*	M933-10025-82	M10-1.50 x 25	Flat Head Machine Screws	
M931-10100-60	M10-1.50 x 100	M961-10030-60	M10-1.25 x 30	M965A-04012-SS	M4-0.70 x 12
M931-10110-60	M10-1.50 x 110	M933-10030-60	M10-1.50 x 30	M965A-05012-SS	M5-0.80 x 12
M931-10120-60	M10-1.50 x 120	M933-10030-82	M10-1.50 x 30*	M965A-05016-20	M5-0.80 x 16
M931-10130-60	M10-1.50 x 130	M961-10035-60	M10-1.25 x 35	M965A-06012-20	M6-1.00 x 12
M931-10140-60	M10-1.50 x 140	M933-10035-60	M10-1.50 x 35		
M931-10180-60	M10-1.50 x 180	M933-10035-82	M10-1.50 x 35		
M960-10330-60	M10-1.25 x 330	M961-10040-60	M10-1.25 x 40		
M931-12045-60	M12-1.75 x 45	M933-12016-60	M12-1.75 x 16		
M960-12050-60	M12-1.25 x 50	M933-12020-60	M12-1.75 x 20		
M960-12050-82	M12-1.25 x 50*	M961-12020-60F	M12-1.50 x 20		
M931-12050-60	M12-1.75 x 50	M933-12025-60	M12-1.75 x 25		
M931-12050-82	M12-1.75 x 50	M933-12025-82	M12-1.75 x 25*		
M931-12055-60	M12-1.75 x 55	M961-12030-60	M12-1.25 x 30		
M931-12060-60	M12-1.75 x 60	M961-12030-82F	M12-1.50 x 30		
M931-12060-82	M12-1.75 x 60	M933-12030-60	M12-1.75 x 30		
M931-12065-60	M12-1.75 x 65	M933-12035-60	M12-1.75 x 35		
M931-12075-60	M12-1.75 x 75	M961-12040-82	M12-1.25 x 40*		
M931-12080-60	M12-1.75 x 80	M933-12040-60	M12-1.75 x 40		
M931-12090-60	M12-1.75 x 90	M933-12040-82	M12-1.75 x 40*		
M931-12100-60	M12-1.75 x 100	M933-12040-82	M12-1.75 x 40*		
M931-12110-60	M12-1.75 x 110				

* This metric hex bolt's hardness is grade 10.9.

Metric, continued

Part No.	Dimensions	Type
Hex Nuts		
M934-03-50	M3-0.50	Standard
M934-04-50	M4-0.70	Standard
M934-05-50	M5-0.80	Standard
M982-05-60	M5-0.80	Elastic Stop
M934-06-60	M6-1.00	Standard
M934-06-64	M6-1.00	Std. (green)
M6923-06-80	M6-1.00	Spirallock
M982-06-80	M6-1.00	Elastic Stop
M934-08-60	M8-1.25	Standard
M6923-08-80	M8-1.25	Spirallock
M982-08-80	M8-1.25	Elastic Stop
M934-10-60	M10-1.50	Standard
M934-10-60F	M10-1.25	Standard
M6923-10-80	M10-1.50	Spirallock
M6923-10-62	M10-1.50	Spirallock†
M982-10-80	M10-1.50	Elastic Stop
M934-12-60	M12-1.75	Standard
M934-12-60F	M12-1.25	Standard
M6923-12-80	M12-1.75	Spirallock
M982-12-80	M12-1.75	Elastic Stop
M982-14-60	M14-2.00	Elastic Stop
M6923-16-80	M16-2.00	Spirallock
M982-16-80	M16-2.00	Elastic Stop
M934-18-80	M18-2.5	Standard
M982-18-60	M18-2.50	Elastic Stop
M934-20-80	M20-2.50	Standard
M982-20-80	M20-2.50	Elastic Stop
M934-22-60	M22-2.50	Standard
M934-24-80	M24-3.00	Standard
M982-24-60	M24-3.00	Elastic Stop
M934-30-80	M30-3.50	Standard

Washers

Part No.	ID	OD	Thick.	Bolt/ Screw
M125A-03-80	3.2	7.0	0.5	M3
M125A-04-80	4.3	9.0	0.8	M4
M125A-05-80	5.3	10.0	1.0	M5
M125A-06-80	6.4	12.0	1.6	M6
M125A-08-80	8.4	16.0	1.6	M8
M125A-10-80	10.5	20.0	2.0	M10
M125A-12-80	13.0	24.0	2.5	M12
M125A-14-80	15.0	28.0	2.5	M14
M125A-16-80	17.0	30.0	3.0	M16
M125A-18-80	19.0	34.0	3.0	M18
M125A-20-80	21.0	37.0	3.0	M20
M125A-24-80	25.0	44.0	4.0	M24

† This metric hex nut's hardness is grade 8.

TP-5847 3/03b

© 1997, 2003 by Kohler Co. All rights reserved.

KOHLER[®] POWER SYSTEMS

KOHLER CO. Kohler, Wisconsin 53044
Phone 920-565-3381, Fax 920-459-1646
For the nearest sales/service outlet in the
US and Canada, phone 1-800-544-2444
KohlerPowerSystems.com

Kohler Power Systems
Asia Pacific Headquarters
7 Jurong Pier Road
Singapore 619159
Phone (65)264-6422, Fax (65)264-6455