

**INSTALLATION INSTRUCTIONS**

Original Issue Date: **9/03**

Model: **Automatic Transfer Switches Equipped with the Programmable Controller**

Market: **ATS**

Subject: **External Battery Supply Module Kit GM26139-KP1**

**Introduction**

This document provides assembly and setup instructions for the external battery supply module (EBSM) kit. The external battery supply module kit is required in order to provide 12 VDC power to the ATS controller from the generator set engine start battery(ies) or other batteries in the following applications:

- **Systems using extended engine start time delays.** The EBSM provides power to the ATS controller during extended time delays longer than 15 seconds, when neither the Normal nor the Emergency source is available.
- **Three-source systems.** Three-source systems use two transfer switches and two standby power sources in addition to the preferred power source. The EBSM provides power to the second ATS controller when the preferred source (connected to ATS1) is supplying the load.

The external battery supply module kit includes one external battery supply circuit board and the circuit board mounting components. See Figure 1.

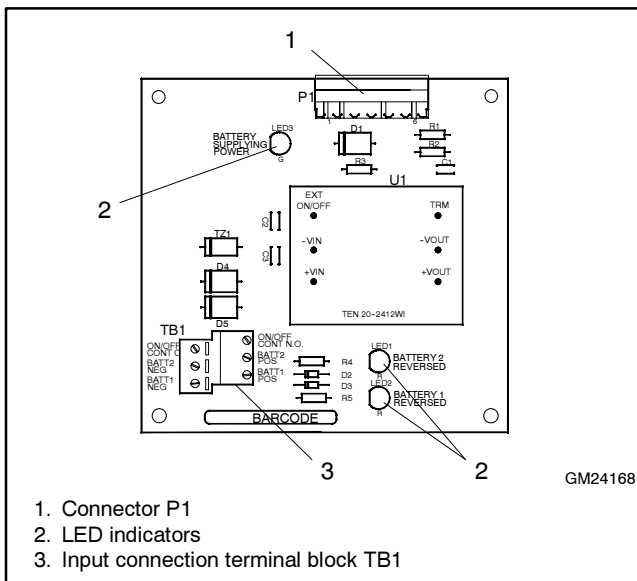

**Figure 1** External Battery Supply Module

The EBSM produces 12 VDC output with 9–36 VDC input. The EBSM input is reverse-polarity protected. Connect one or two batteries to the external battery supply module.

**Requirements**

The following items are required for kit installation, setup, and operation. The transfer switch may already be equipped with the necessary I/O mounting assembly and I/O module.

An **I/O module mounting assembly kit** is required for installation of the external battery supply module. See Figure 2. The module connects to an adjacent I/O module or to the interface harness included with the I/O module mounting assembly kit. The I/O module mounting assembly kit allows the installation of up to three I/O modules plus one external battery supply module. Obtain kit GM21360-KP1 if the transfer switch is not already equipped with a mounting kit and follow the instructions provided with the kit to install the mounting assembly.

The system may require a **programmable input/output (I/O) module** for connection of the external battery supply module. See NO TAG for extended time delay systems or Figure 14 for three-source systems and check the transfer switch(es) for the required number of available programmable inputs and outputs. If the ATS does not have the required number of inputs and outputs available, obtain Programmable Input/Output Module Kit GM21359-KP1 and follow the instructions supplied with the kit to install the I/O module before installing the external battery supply module. A maximum of three I/O modules can be installed with the EBSM.

**A personal computer running the Setup Program** is required to configure the inputs and outputs for all systems using the external battery supply module. **Setup Program version 1.3.0 or higher** is required for setting up three-source systems. **Setup Program version 1.6.1 or higher** is required to set up extended

engine start time delays. Refer to the Setup Program Operation Manual to set up the I/O circuit board communications and to define the I/O circuit board inputs and outputs.

For a three-source system, verify that your ATS controller uses **main logic software version 1.21** or higher by using the Setup Program to view the System Information data window. Refer to the Setup Program Operation Manual for instructions. Contact the factory for the latest version of the main logic software if your controller does not have version 1.21 or higher. Use the Program Loader to load the latest version of the software onto the controller. See TT-1285 for Program Loader instructions.

Use a **battery charger** to maintain the battery(ies) connected to the EBSM. The ATS controller draws 800 mAmps during normal operation. Optional I/O modules can increase the current draw to a maximum of 1.5 amps.

Read the entire installation procedure and compare the kit parts with the parts list at the end of this publication before beginning installation. Perform the steps in the order shown.

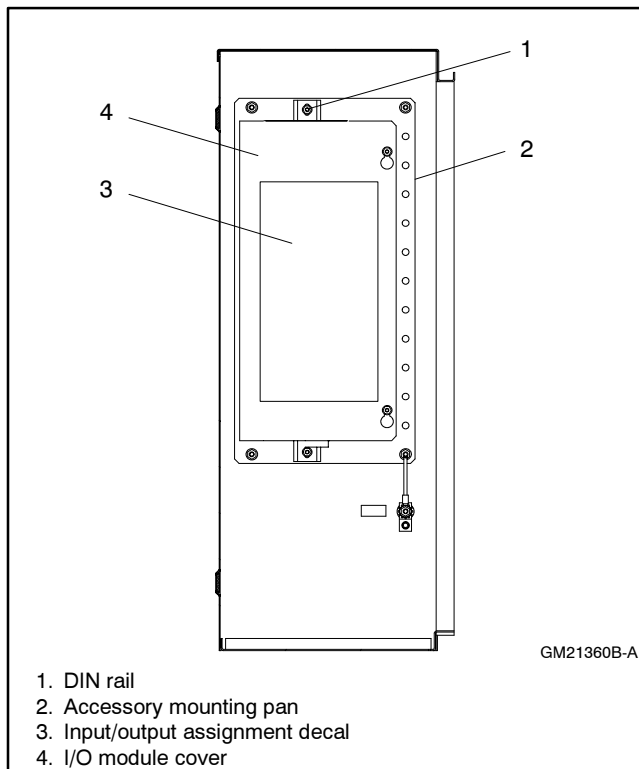

**Figure 2** I/O Module Mounting Assembly Kit, Typical

## Safety Precautions

Observe the following safety precautions during installation.

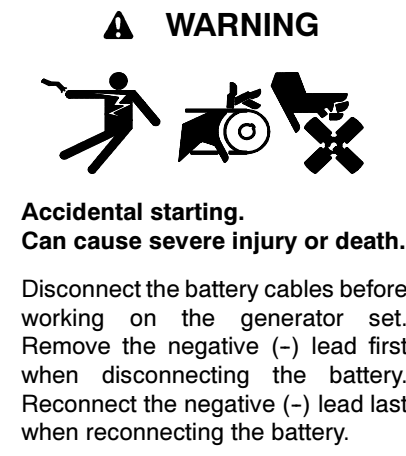
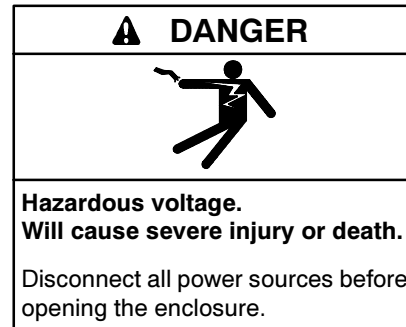

**Disabling the generator set. Accidental starting can cause severe injury or death.** Before working on the generator set or connected equipment, disable the generator set as follows: (1) Move the generator set master switch to the OFF position. (2) Disconnect the power to the battery charger. (3) Remove the battery cables, negative (-) lead first. Reconnect the negative (-) lead last when reconnecting the battery. Follow these precautions to prevent starting of the generator set by an automatic transfer switch, remote start/stop switch, or engine start command from a remote computer.

**Grounding electrical equipment. Hazardous voltage can cause severe injury or death.** Electrocutation is possible whenever electricity is present. Open the main circuit breakers of all power sources before servicing the equipment. Configure the installation to electrically ground the generator set, transfer switch, and related equipment and electrical circuits to comply with applicable codes and standards. Never contact electrical leads or appliances when standing in water or on wet ground because these conditions increase the risk of electrocution.

**Short circuits. Hazardous voltage/current can cause severe injury or death.** Short circuits can cause bodily injury and/or equipment damage. Do not contact electrical connections with tools or jewelry while making adjustments or repairs. Remove all jewelry before servicing the equipment.

## NOTICE

**Electrostatic discharge damage.** Electrostatic discharge (ESD) damages electronic circuit boards. Prevent electrostatic discharge damage by wearing an approved grounding wrist strap when handling electronic circuit boards or integrated circuits. An approved grounding wrist strap provides a high resistance (about 1 megohm), *not a direct short*, to ground.

## Circuit Board Handling

Improper removal, installation, transportation, storage, or service can damage sensitive electronic components. Observe the following guidelines to prevent damage when working with circuit boards or electronic components.

### Circuit Board and Electronic Component Handling

- Keep circuit boards or electronic components inside the antistatic, cushioned factory packaging until installation.
- Store circuit boards or electronic components in a clean environment away from moisture, vibration, static electricity, corrosive chemicals, and solvents.
- Disconnect all power sources before removing or installing circuit boards or electronic components.
- Wear an approved, grounded, antistatic wrist strap when handling circuit boards or electronic components.
- Carefully hold the circuit board by its edges and not by any of its components or electrical contacts.
- Do not drop the circuit board or electronic components.
- Do not bend the circuit board, electronic components, or electronic component leads.
- Do not strike the circuit board or electronic components using or against a hard object.
- Clean dusty or dirty circuit boards with a vacuum cleaner or soft, dry brush.
- Never attempt circuit board repairs, adjustments, or modifications other than replacing plug-in service parts or performing manufacturer-approved installation or service procedures.

t:ta:001:001:a

## External Battery Supply Module Diagnostic LEDs

The EBSM includes three LED indicators:

- LEDs 1 and 2 illuminate if the battery polarity is reversed. Reverse the battery connections at EBSM TB1 if the corresponding LED lights.
- LED3 illuminates when the EBSM is on, supplying power to the ATS controller.

## Installation Procedure

### 1. Assembling the external battery supply module kit GM26139-KP1

- 1.1 Place the three PC mounting modules (GM21332) side-by-side. Position all modules with the back mounting clips the same way. See Figure 3.
- 1.2 Install four PC mounting pins (GM21333) in one side of the first PC mounting module.
- 1.3 Align the PC mounting pins with the second PC mounting module and push together. The PC mounting modules also have small plastic locking pins that lock together.
- 1.4 Repeat steps 1.2 and 1.3 for the third PC mounting module.

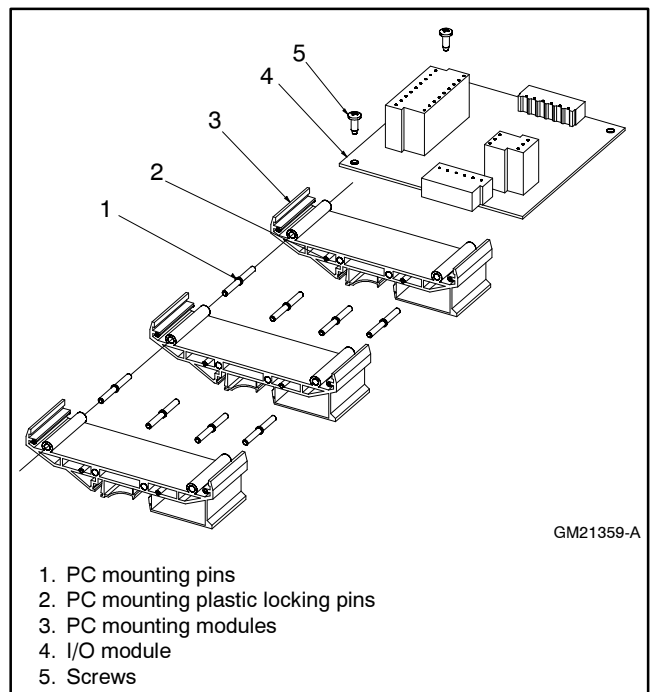

**Figure 3** Assembling the I/O Module Kit

- 1.5 Carefully install the external battery supply circuit board (GM24168) in the PC mounting module grooves as shown in Figure 3.
  - 1.6 Align the external battery supply circuit board edge flush with the PC mounting module. Place the two screws (X-67-143) through the circuit board holes and thread into the PC mounting modules. See Figure 4.
- 2. Removing the generator set and transfer switch from service**
- 2.1 Place all generator set master switches in the OFF position.
  - 2.2 Disconnect the power to all battery chargers, if equipped.
  - 2.3 Disconnect all generator set engine starting battery(ies), negative (-) leads first.
  - 2.4 Disconnect all power sources to transfer switches and power monitors.
  - 2.5 Turn off and disconnect the power to all devices in the system.
  - 2.6 Open the transfer switch enclosure.

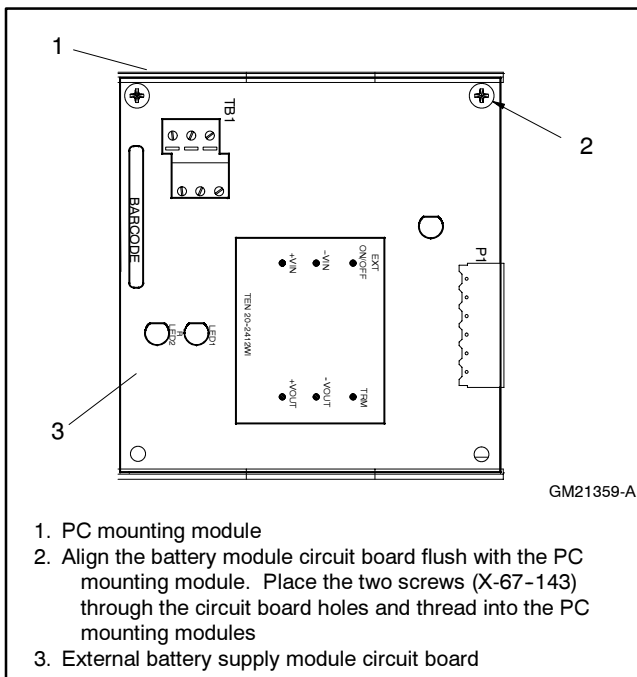

**Figure 4** Installing the EBSM Circuit Board to the PC Mounting Modules

**3. Installing the I/O module mounting assembly kit GM21360-KP1**

Follow the instructions provided with the I/O module mounting assembly kit to install the mounting assembly inside the transfer switch enclosure. See Figure 5 for the mounting assembly location inside the transfer switch enclosure. If the transfer switch already has an I/O module mounting assembly kit installed, proceed to step NO TAG.

**4. Installing the programmable I/O module, if necessary, and the external battery supply module**

**Note:** See NO TAG for extended time delay systems or Figure 14 for three-source systems and check the transfer switch(es) for the required number of available programmable inputs and outputs.

- 4.1 If an additional programmable I/O module is required, install the I/O module onto the DIN rail in the position shown in Figure 6. Attach by tilting the I/O module slightly back and aligning the first index slot and then pushing the other side of the I/O module toward the DIN rail. See Figure 7.

**Note:** To remove an I/O module or EBSM from the DIN rail, place a large slotted screwdriver in the groove of the module as shown in Figure 8 and apply outward pressure to release the module. Repeat for each module.

- 4.2 Follow the instructions in step 4.1 to install the external battery supply module onto the DIN rail in the same manner as the I/O module(s). The EBSM kit must be installed last, after all I/O modules.
- 4.3 After installing the I/O modules and the external battery supply module on the DIN rail, slide each I/O module toward I/O module No. 1 to engage the mating electrical connectors. Slide the EBSM toward the last I/O module to engage the mating connectors.

**Note:** To disengage the module mating connectors, carefully place a small slotted screwdriver between the plastic locking tabs and slide the modules apart. See Figure 9.

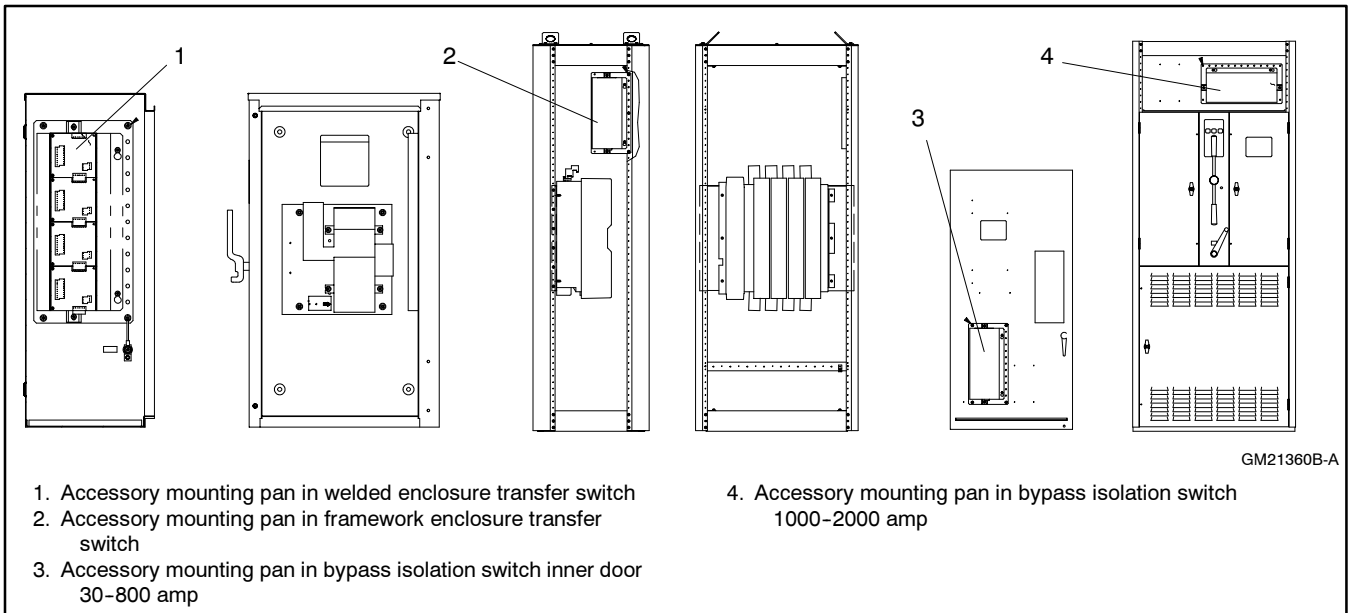

**Figure 5** Accessory Mounting Pan Location and Position

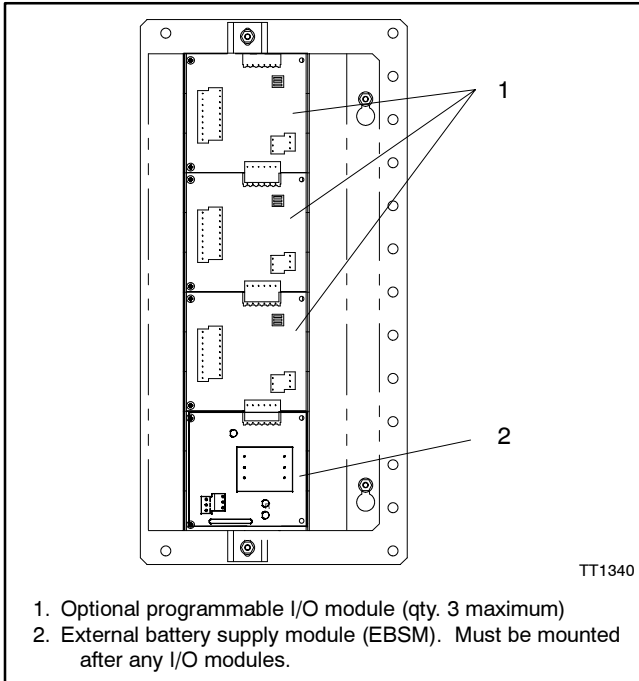

**Figure 6** Mounting Position of I/O Module(s) and EBSM on DIN Rail

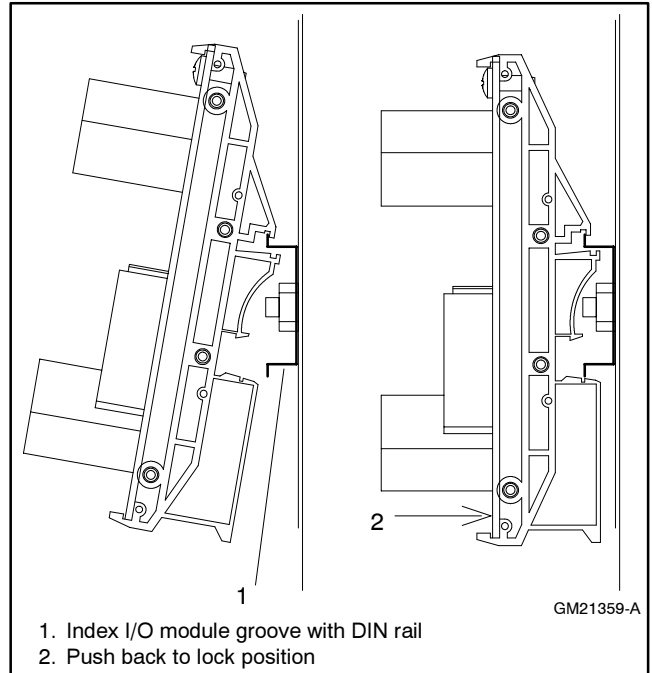

**Figure 7** Installing I/O Circuit Board Module on DIN Rail

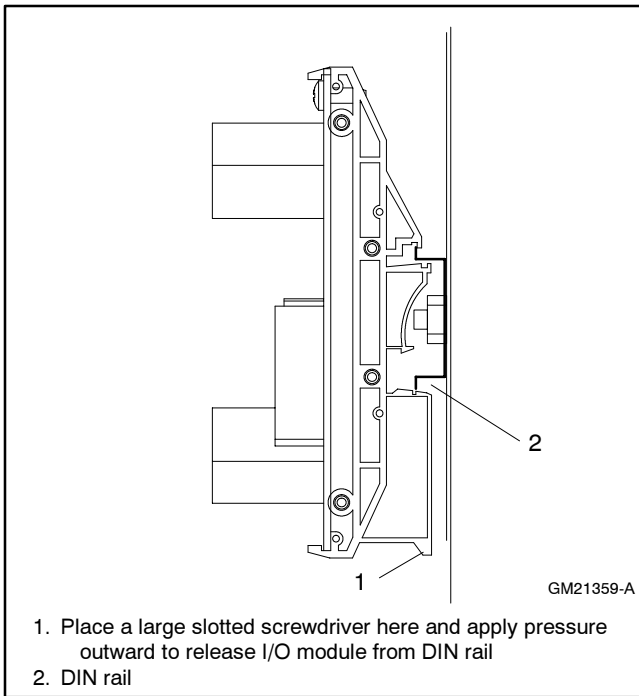

**Figure 8** Removing the I/O Module from the DIN Rail

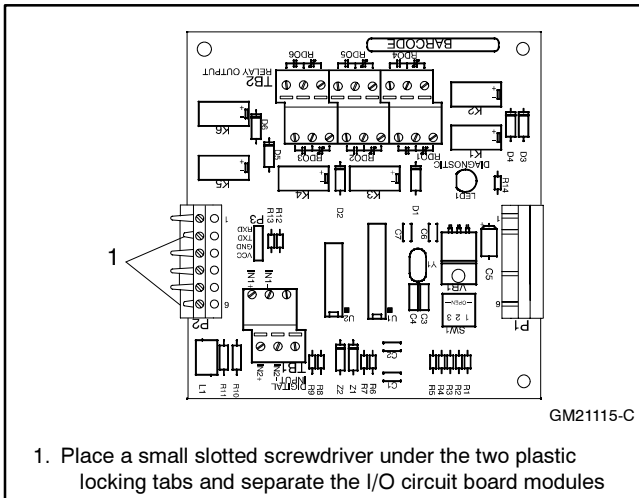

**Figure 9** Separating the Circuit Board Modules at the Electrical Connectors

## 5. Installing the I/O module harness

- 5.1 Locate I/O module No. 1 and install the mating connector of the I/O module harness (GM21341-2). See Figure 10. If no I/O modules are used, connect the harness to the mating connector on the external battery supply module.
- 5.2 Remove the nut from the accessory mounting pan stud as shown in Figure 10. Install the 1/4 in. int./ext. tooth lock washer (X-22-12), eyelet terminal from I/O module harness, 1/4 in. plain washer (X-25-40), and nut. Final tighten all four accessory mounting pan nuts.
- 5.3 Route and connect the other end of the I/O module harness to the transfer switch logic circuit board. See Figure 11.
- 5.4 Attach the cable tie (X-468-9) to the I/O module harness and secure to the transfer switch panel stud using a 1/4-20 nut (X-6210-2).

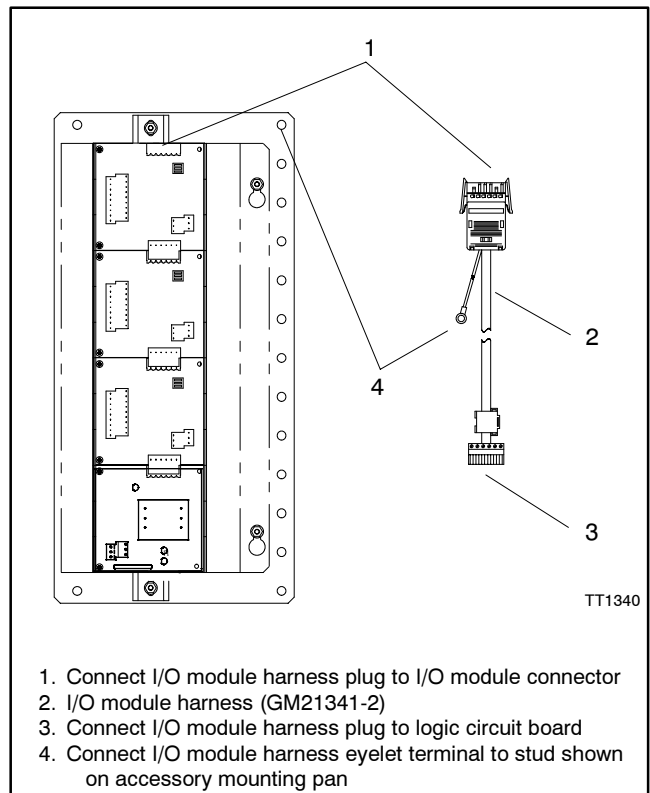

**Figure 10** I/O Circuit Board Module Harness Connector and Ground Connection

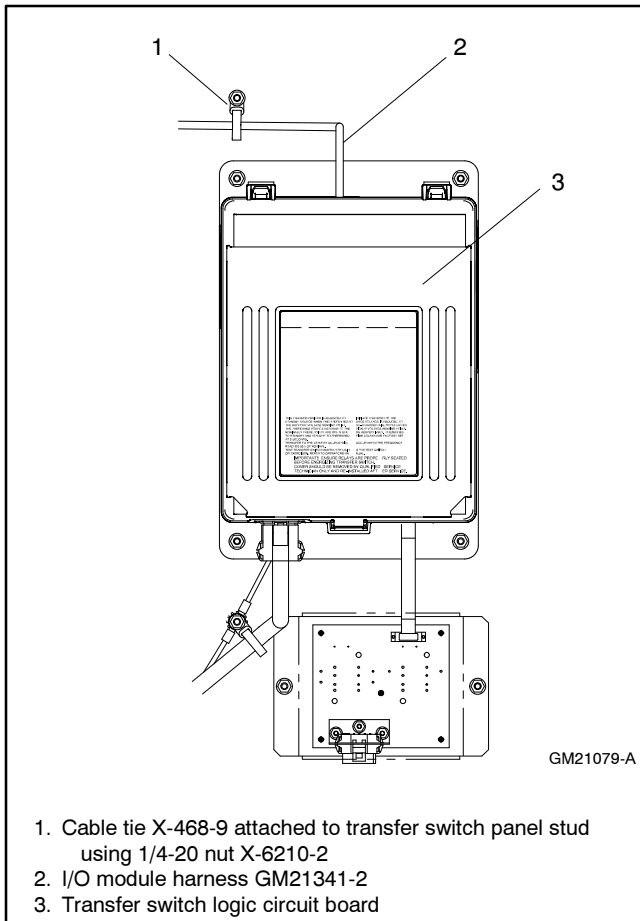

**Figure 11** Connecting I/O Circuit Board Module Harness to Transfer Switch Logic Circuit Board

## 6. Connections and setup for systems with extended time delays

Use wire sizes from #14 AWG to #20 AWG for EBSM and I/O module connections. See Figure 12 for connections during the following steps.

6.1 Optional connections prevent the EBSM from running continuously when a source is available. Connect the normally open (NO) side of one (or two) available programmable output(s) from the ATS controller's main logic board or a programmable I/O module to the terminals labelled ON/OFF on TB1 on the EBSM. See Figure 12. Set the programmable output(s) to Preferred Source Available (and Emergency Source Available) in step 6.4.

6.2 Connect the battery power.

6.2.1 Connect the battery cables for the first battery to TB1 on the EBSM. Connect the positive battery cable to the terminal labelled BATT 1 (+) and connect the negative cable to BATT 1 (-).

6.2.2 For a 24-volt, 2-battery system, connect the second battery to the terminals labelled BATT 2 (+) and BATT 2 (-).

6.3 Check that LEDs 1 and 2 are not illuminated. The LEDs illuminate if the battery polarity is reversed. If either LED1 or LED2 is illuminated, reverse the polarity of the corresponding battery connections to EBSM TB1. The input is reverse-polarity protected.

**Note:** LED1 corresponds to Battery 2 and LED2 corresponds to Battery 1.

6.4 Use the Setup Program to set the programmable output(s), if used. Proceed to step 8 for instructions to assign the outputs.

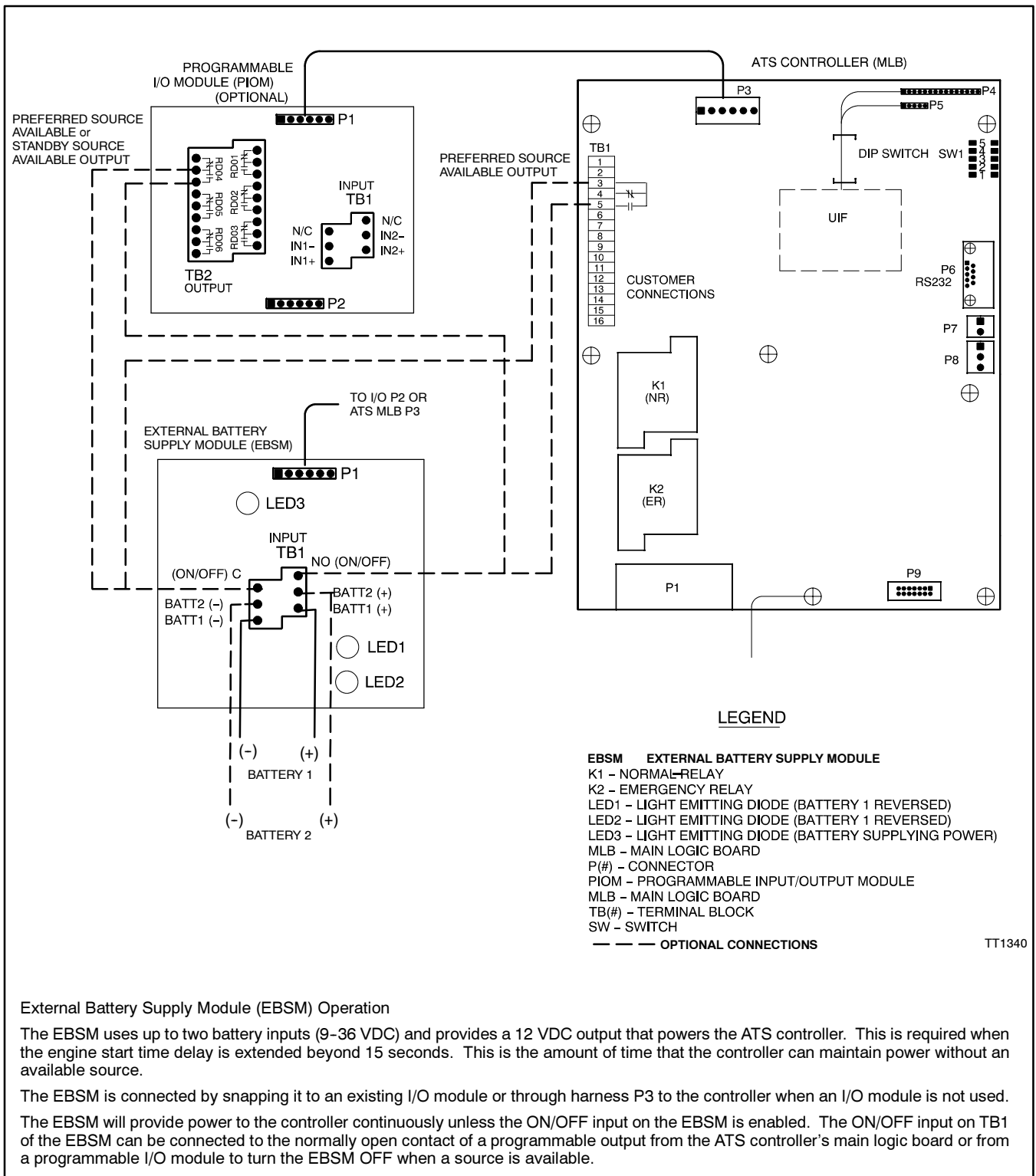

**Figure 12** Connections for Extended Time Delays

**External Battery Supply Module (EBSM) Operation**

The EBSM uses up to two battery inputs (9-36 VDC) and provides a 12 VDC output that powers the ATS controller. This is required when the engine start time delay is extended beyond 15 seconds. This is the amount of time that the controller can maintain power without an available source.

The EBSM is connected by snapping it to an existing I/O module or through harness P3 to the controller when an I/O module is not used.

The EBSM will provide power to the controller continuously unless the ON/OFF input on the EBSM is enabled. The ON/OFF input on TB1 of the EBSM can be connected to the normally open contact of a programmable output from the ATS controller's main logic board or from a programmable I/O module to turn the EBSM OFF when a source is available.

## 7. Connections and setup for three-source systems

See Figure 13 and Figure 14 for connections during the following steps.

7.1 Connect the power sources to the transfer switches as described below. Refer to the transfer switch Operation/Installation manual or specification sheet for cable sizes. See Figure 13 for connections.

7.1.1 Connect the utility power source to the normal side of ATS1.

7.1.2 Connect the load to the load side of ATS1.

7.1.3 Connect the emergency side of ATS1 to the load side of ATS2.

7.1.4 Connect generator set 1 to the normal side of ATS2.

7.1.5 Connect generator set 2 to the emergency side of ATS2.

7.2 Three-source systems require the following input/output connections to control the engine start commands for generator sets 1 and 2. Observe the polarity of all connections shown in Figure 14. Use wire sizes from #14 AWG to #20 AWG for EBSM and I/O module connections.

7.2.1 Connect the ATS2 engine start contacts to the engine start circuit on generator set 2 (G2).

**Note:** The ATS engine start contacts are located on the contactor (on 30–400 amp models) or on the field-connection terminal block (on 600–4000 amp models) and are labeled with a red decal.

7.2.2 Connect the ATS1 main logic board programmable output terminals TB1-3 and TB1-5 to ATS2 main logic board programmable input 1 terminals TB1-6 and TB1-7 as shown in Figure 14. This I/O connection will be set to “Three-Source System Disable.”

7.2.3 Connect ATS2 main logic board programmable output terminals TB1-3 and TB1-4 to the engine start connection on generator set 1 (G1). The ATS1 programmable output will be set to “Start Source N Generator.”

7.2.4 Optional. Connect the normally open side of any available output on the I/O module on ATS2 to the ON/OFF terminals on external battery supply module terminal strip TB1. The ATS2 I/O module output will be set to “Preferred Source Available.” (This optional connection turns off the EBSM when source G1 is available.)

7.2.5 Optional. Connect the normally open side of any available output on the I/O module on ATS2 to the ON/OFF terminals on external battery supply module terminal strip TB1. The ATS2 I/O module output will be set to “Standby Source Available.” (This optional connection turns off the EBSM when source G2 is available.)

7.3 Connect battery power. Connect the battery cables for the first battery to TB1 on the EBSM. Connect the positive battery cable to the terminal labelled BATT 1 (+) and connect the negative cable to BATT 1 (-).

For a 24-volt, 2-battery system, connect the second battery to the terminals labelled BATT 2 (+) and BATT 2 (-).

Check that LEDs 1 and 2 are not illuminated. The LEDs illuminate if the battery polarity is reversed. If either LED is illuminated, reverse the polarity of the corresponding battery connections to EBSM TB1.

**Note:** LED1 corresponds to Battery 2 and LED2 corresponds to Battery 1.

7.4 Use the Setup Program to assign inputs and outputs. See step 8 for instructions.

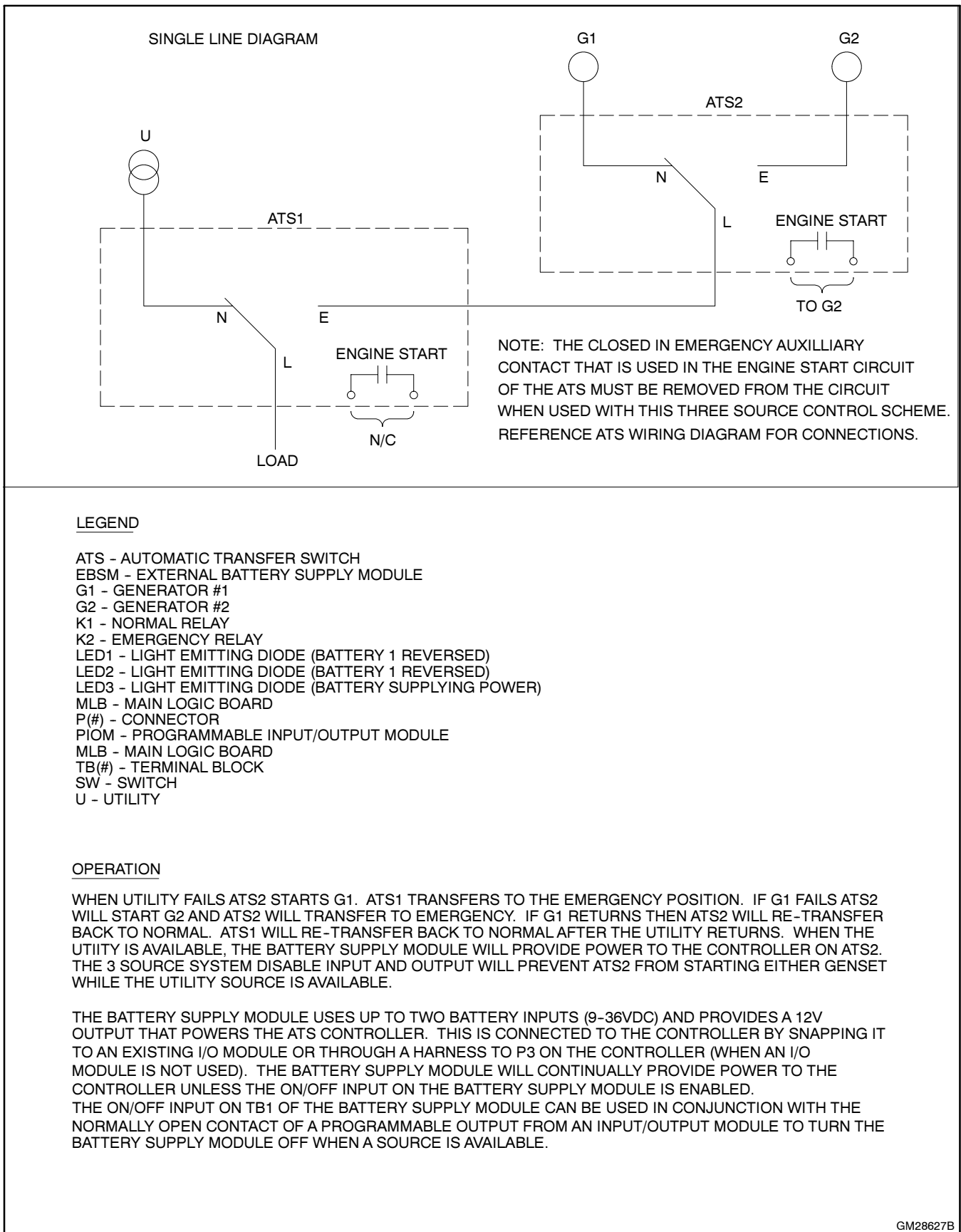

**Figure 13** Three-Source System Transfer Switch and Source Connections

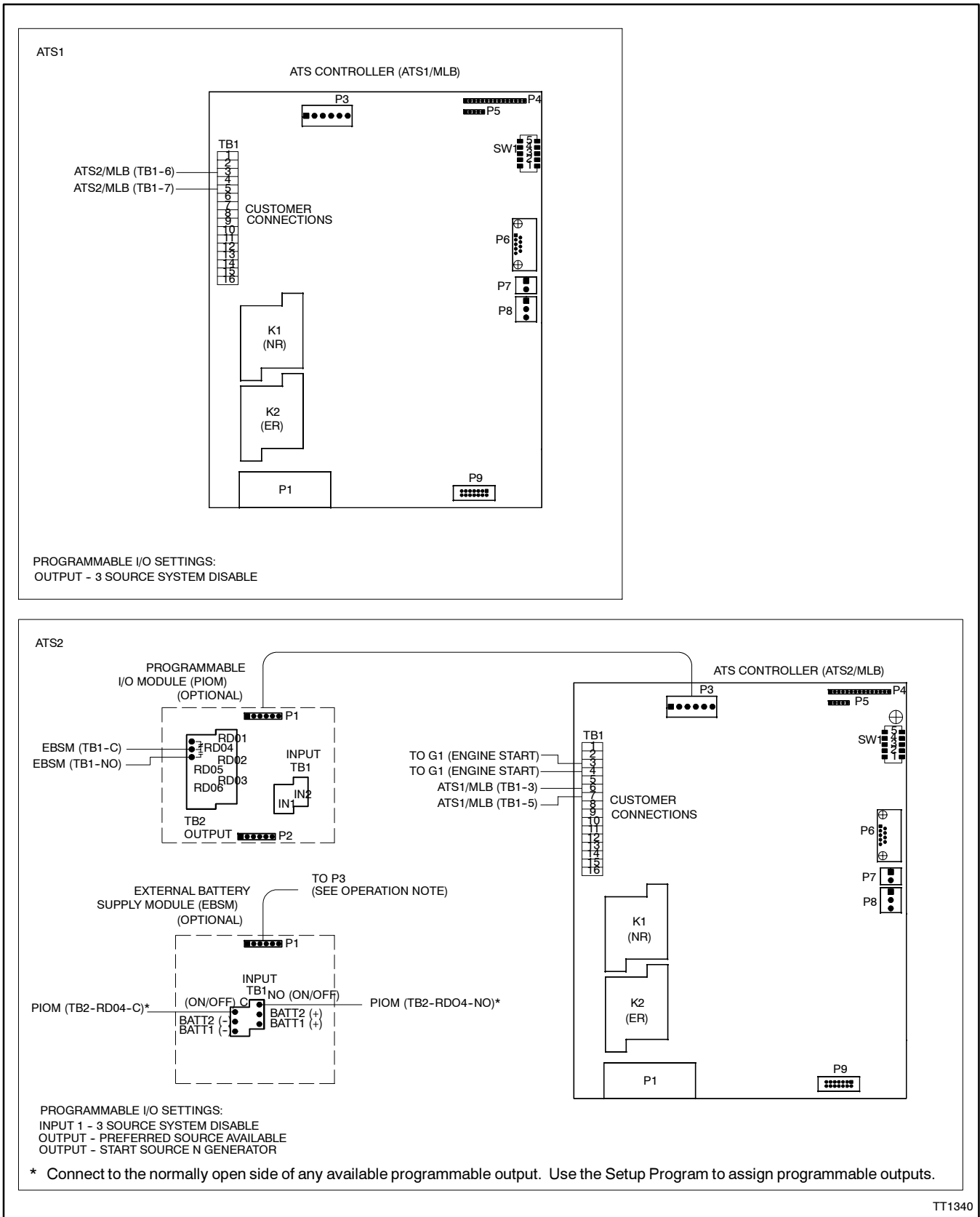

Figure 14 Input and Output Connections for Three-Source Systems

## 8. Assigning the programmable inputs and outputs

**Note:** The Setup Program is required for assigning programmable inputs and outputs. See the Setup Program Operation and Installation Manual for more information about the Setup Program during the following steps.

**Note:** For extended time delays, programmable outputs need to be assigned only if the optional connections in step 6.1 are used.

8.1 Connect a personal computer (PC) to the ATS controller. See the Setup Program Operation and Installation Manual for instructions to connect the PC. Follow the instructions in the manual to install the Setup Program on the PC, if necessary.

8.2 Start the Setup Program.

8.3 Select Connection>Connect to establish communication with the transfer switch controller.

8.4 Select Window>New Window to bring up the list of data windows.

8.5 Select Programmable Input/Output from the list and click OK to create the Programmable I/O data window on the PC's screen. See Figure 15. Then choose Window>Setup or double-click on the Programmable I/O window to bring up the setup screen shown in Figure 16.

8.6 To determine the required input and output assignments, refer to step 6.4 for extended time delays or step 7.4 for three-source systems.

8.7 Identify the location of the input or output connection to be assigned: one of the input or output connections on the main logic board terminal strip TB1 or one of the programmable I/O modules. See Figure 16.

**Note:** For I/O modules, be sure to select the module address on the left side of the setup window before assigning the input/output. See Figure 16.

8.8 For **extended time delays**, assign the following outputs, if used.

**Note:** These are optional connections.

8.8.1 Set the programmable output connected to the EBSM to Preferred Source Available, if used.

8.8.2 If two programmable outputs are connected to the EBSM ON/OFF

terminals, set the second output to Standby Source Available.

8.9 For **three-source systems**, assign the following inputs and outputs.

8.9.1 Assign the ATS1 programmable output connected in step 7.2.2 to "Three-Source System Disable."

8.10 Click OK to save the input/output assignment(s) and close the setup window.

8.11 For three-source systems, connect the PC to ATS2 and assign the following inputs and outputs for the second transfer switch.

8.11.1 Assign ATS2 main logic board programmable input 1 to "Three-Source System Disable."

8.11.2 Assign the ATS2 main logic board programmable output connected in step 7.2.3 to "Start Source N Generator."

8.11.3 Optional. Assign the ATS2 I/O module output connected in step 7.2.4 to "Preferred Source Available."

8.11.4 Optional. Assign the ATS2 I/O module output connected in step 7.2.5 to "Emergency Source Available."

8.12 Click OK to save the input/output assignment(s) and close the setup window.

8.13 Follow the instructions in the Setup Program Operation and Installation Manual to exit the program and disconnect the PC.

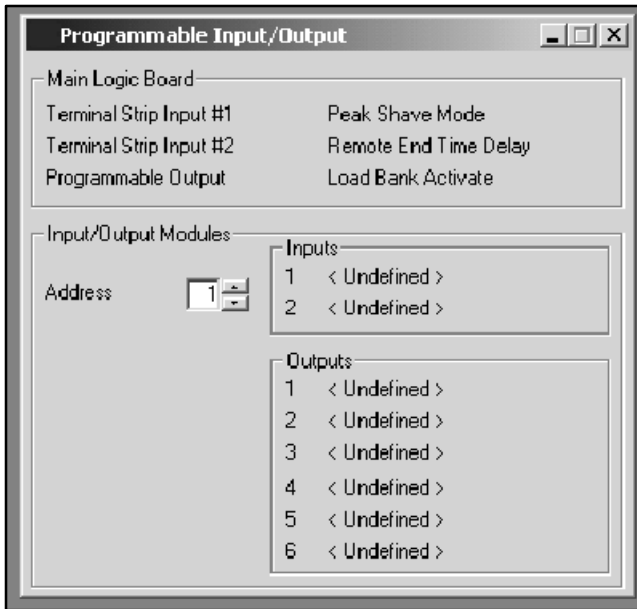

**Figure 15** Programmable Input/Output Display

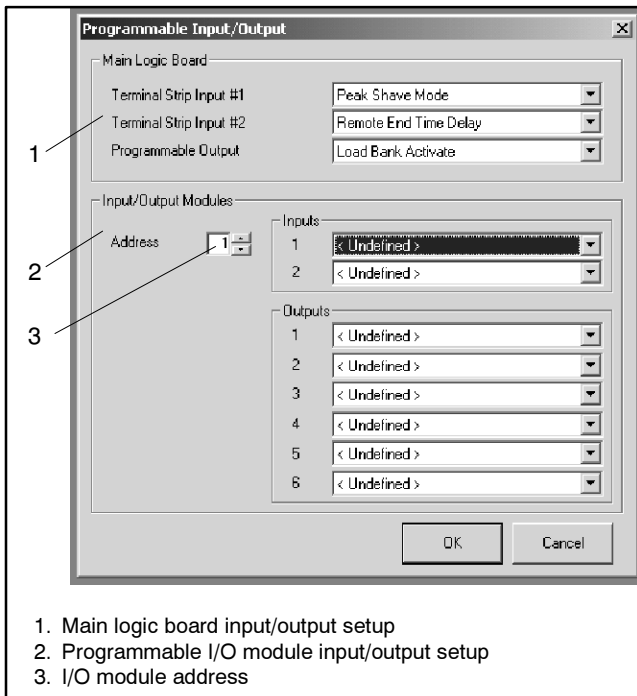

**Figure 16** Programmable Input/Output Setup Window

## 9. Installing the I/O module cover

- 9.1 Use cable ties as necessary to secure and protect all input/output and external battery supply module wiring.
- 9.2 Install the I/O module cover (GM21334) using two 10-32 nuts (X-6210-1). See Figure 17.
- 9.3 Record the input and output connections on the decal. See Figure 18.
- 9.4 Write "External Battery Supply Module" in the space on the decal that corresponds to the board location (i.e., Address 1,2,3, or 4).
- 9.5 With surfaces clean and dry, attach the decal to the I/O module cover.

**Note:** The decal may be shipped already attached to the I/O module cover.

## 10. Restoring the generator set and transfer switch to service

- 10.1 Close and secure the transfer switch enclosure door.
- 10.2 Check that all generator set master switches are in the OFF position.
- 10.3 Reconnect the generator set engine starting battery(ies), negative (-) leads last.
- 10.4 Reconnect power to the battery charger, if equipped.
- 10.5 Reconnect all power sources to the transfer switches and power monitors.
- 10.6 Place all generator set master switches to the AUTO position.

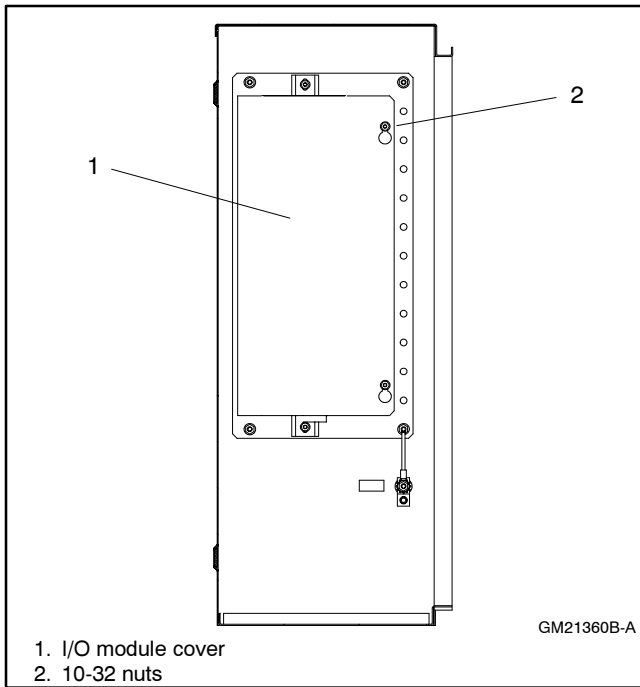

Figure 17 Installing I/O Module Cover

INPUT/OUTPUT MODULE ASSIGNMENTS

ADDRESS 1  
 INPUT 1 (TB1-IN1) \_\_\_\_\_  
 INPUT 2 (TB1-IN2) \_\_\_\_\_  
 OUTPUT 1 (TB2-RD01) \_\_\_\_\_  
 OUTPUT 2 (TB2-RD02) \_\_\_\_\_  
 OUTPUT 3 (TB2-RD03) \_\_\_\_\_  
 OUTPUT 4 (TB2-RD04) \_\_\_\_\_  
 OUTPUT 5 (TB2-RD05) \_\_\_\_\_  
 OUTPUT 6 (TB2-RD06) \_\_\_\_\_

ADDRESS 2  
 INPUT 1 (TB1-IN1) \_\_\_\_\_  
 INPUT 2 (TB1-IN2) \_\_\_\_\_  
 OUTPUT 1 (TB2-RD01) \_\_\_\_\_  
 OUTPUT 2 (TB2-RD02) \_\_\_\_\_  
 OUTPUT 3 (TB2-RD03) \_\_\_\_\_  
 OUTPUT 4 (TB2-RD04) \_\_\_\_\_  
 OUTPUT 5 (TB2-RD05) \_\_\_\_\_  
 OUTPUT 6 (TB2-RD06) \_\_\_\_\_

ADDRESS 3  
 INPUT 1 (TB1-IN1) \_\_\_\_\_  
 INPUT 2 (TB1-IN2) \_\_\_\_\_  
 OUTPUT 1 (TB2-RD01) \_\_\_\_\_  
 OUTPUT 2 (TB2-RD02) \_\_\_\_\_  
 OUTPUT 3 (TB2-RD03) \_\_\_\_\_  
 OUTPUT 4 (TB2-RD04) \_\_\_\_\_  
 OUTPUT 5 (TB2-RD05) \_\_\_\_\_  
 OUTPUT 6 (TB2-RD06) \_\_\_\_\_

ADDRESS 4  
 INPUT 1 (TB1-IN1) \_\_\_\_\_  
 INPUT 2 (TB1-IN2) \_\_\_\_\_  
 OUTPUT 1 (TB2-RD01) \_\_\_\_\_  
 OUTPUT 2 (TB2-RD02) \_\_\_\_\_  
 OUTPUT 3 (TB2-RD03) \_\_\_\_\_  
 OUTPUT 4 (TB2-RD04) \_\_\_\_\_  
 OUTPUT 5 (TB2-RD05) \_\_\_\_\_  
 OUTPUT 6 (TB2-RD06) \_\_\_\_\_

SW1 SETTINGS			
ADDRESS	SW1-1	SW1-2	SW1-3
1	C	C	C
2	C	C	O
3	C	O	C
4	C	O	O

THIS SIDE DOWN = OPEN      THIS SIDE DOWN = CLOSED

GM23621-  
GM23621-

Figure 18 Decal for Input and Output Assignments

## Parts Lists

### External Battery Supply Module Kit

Kit: GM26139-KP1		
Qty.	Description	Part Number
3	Module, PC mounting	GM21332
8	Pin, PC mounting	GM21333
1	PCB Assy.	GM24168
2	Screw, cross recess, sheet metal	X-67-143

### I/O Module Mounting Assembly Kit

Kit: GM21360-KP1		
Qty.	Description	Part Number
1	Pan, accessory mounting	GM21330
1	Rail, DIN	GM21328
1	Cover, I/O module	GM21334
1	Harness, I/O module	GM21341-2
1	Tie, cable with mounting	X-468-9
4	Nut, 10-32	X-6210-1
5	Nut, 1/4-20	X-6210-2
1	Decal	GM23621
1	Washer, 1/4 in. int./ext. tooth lock	X-22-12
1	Washer, 1/4 in. plain	X-25-40



