

# Operation and Installation

## Automatic Transfer Switches

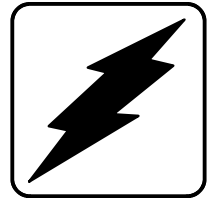

Models:

**MMS/MNS**

**MMT/MNT**

**TES/TLS**

**ZCS/ZCB**

Electrical Controls:

M340+ Microprocessor

**ISO 9001**  
**KOHLER**  
GENERATORS  
INTERNATIONALLY REGISTERED

**KOHLER**<sup>®</sup>  
POWER SYSTEMS

TP-5664 6/94c

# Table of Contents

SUBJECT	PAGE	SUBJECT	PAGE
<b>Safety Precautions and Instructions</b> .....	<b>I</b>	Settings, and Set Points .....	4-10
<b>Introduction</b> .....	<b>i</b>	Index 7—Emergency-Source Voltage, Frequency Settings, and Set Points .....	4-13
List of Related Materials .....	i	Index 8—Plant Exerciser Settings .....	4-16
<b>Service Assistance</b> .....	<b>i</b>	Calendar Mode .....	4-17
<b>Section 1. Specifications</b> .....	<b>1-1</b>	14-Day Mode .....	4-19
Purpose of Switch .....	1-1	7-Day Mode .....	4-21
Components of Switch .....	1-1	One-Time Exercise .....	4-23
Ratings .....	1-2	Index 9—Load-Shed Settings .....	4-24
Interpreting a Transfer Switch Part Number .....	1-3	Index 10—Source History .....	4-26
Specifications .....	1-4	Index 11—Installed Control Options .....	4-27
Standard Features .....	1-4	Index 12—Voltage-Sensing Calibration .....	4-29
Shunt/Jumper-Controlled Accessories .....	1-5	Index 13—Remote Control and Monitoring Settings .....	4-30
Optional Accessories .....	1-6	<b>Section 5. Programming Switch</b>	
<b>Section 2. Operation</b> .....	<b>2-1</b>	<b>Local Mode</b> .....	<b>5-1</b>
Control Switches and Indicators .....	2-1	Index List .....	5-1
LED Indicators .....	2-1	Index 1—Normal-Source Voltage and Frequency .....	5-2
System Status .....	2-1	Index 2—Emergency-Source Voltage and Frequency .....	5-4
Time Delays .....	2-2	Index 2—Emergency-Source Voltage and Frequency .....	5-4
Accessory Active .....	2-2	Index 3—Records, Total and Resettable .....	5-6
Programming Mode Switch .....	2-2	Index 4—Clock and Calendar .....	5-8
Control Switches .....	2-3	Index 5—Time Delays .....	5-10
Sequence of Operation .....	2-4	Index 6—Normal-Source Voltage, Frequency Settings, and Set Points .....	5-12
Sequence of Operation Standard Switch .....	2-4	Index 7—Emergency-Source Voltage, Frequency Settings, and Set Points .....	5-16
When the Normal Source Fails .....	2-4	Index 8—Plant Exerciser Settings .....	5-20
When the Normal Source Returns .....	2-5	Calendar Mode .....	5-21
Sequence of Operation Programmed Transition Switch .....	2-7	14-Day Mode .....	5-24
When the Normal Source Fails .....	2-7	7-Day Mode .....	5-27
When the Normal Source Returns .....	2-8	One-Time Exercise .....	5-29
<b>Section 3. Programming Information</b> .....	<b>3-1</b>	Index 9—Load-Shed Settings .....	5-31
General Programming Information .....	3-1	Index 10—Source History .....	5-33
Hardware .....	3-1	Index 11—Installed Control Options .....	5-34
Software .....	3-3	Index 12—Voltage-Sensing Calibration .....	5-35
<b>Section 4. Programming Switch Off Mode</b> ...	<b>4-1</b>	Index 13—Remote Control and Monitoring Settings .....	5-36
Index List .....	4-1	<b>Section 6. Programming Switch</b>	
Index 1—Normal-Source Voltage and Frequency .....	4-2	<b>Remote Mode</b> .....	<b>6-1</b>
Index 2—Emergency-Source Voltage and Frequency .....	4-4	Remote Communications Connections .....	6-1
Index 2—Emergency-Source Voltage and Frequency .....	4-4	Remote Communication Hardware .....	6-1
Index 3—Records, Total and Resettable .....	4-6	Communication Interface Cables .....	6-1
Index 4—Clock and Calendar .....	4-8	Remote Communication Submenu .....	6-2
Index 5—Time Delays .....	4-9		
Index 6—Normal-Source Voltage, Frequency Settings, and Set Points .....	4-10		

<b>Section 7. Accessories</b> .....	<b>7-1</b>	Load-Shedding Contacts DD-35-N .....	7-9
Optional Accessories .....	7-1	Remote Communications Port Adapter	
Emergency Source Sensing DD-05-K .....	7-1	DD-51-A,B .....	7-10
Operation Mode Selector Switch DD-06-N,P .....	7-1	<b>Appendix A. Glossary of Abbreviations</b> .....	<b>A-1</b>
Operation Mode Selector Switch DD-07-D .....	7-1	<b>Appendix B. Source History</b>	
Time Delay Override Switch DD-08-C,D .....	7-1	<b>Message Summary</b> .....	<b>A-3</b>
Auxiliary Relay Contacts		<b>Appendix C. System Alert</b>	
DD-14-G,H,J,K,L,M,N,P,R .....	7-2	<b>Message Summary</b> .....	<b>A-4</b>
Contact Position Auxiliary Contacts DD-15-E,F .....	7-5	<b>Appendix D. Setting Ranges</b> .....	<b>A-5</b>
Auxiliary Meters DD-18-G,J .....	7-5	<b>Appendix E. Initial Setup Worksheets</b> .....	<b>A-6</b>
Plant Exercisers DD-23-D,G .....	7-5	Checking Installed Control Options .....	A-6
Battery Chargers		Time Delays .....	A-6
DD-24-XX-A, B .....	7-6	Normal and Emergency System Set Points .....	A-7
Information Required Prior to		Plant Exerciser Settings .....	A-8
Charging Battery .....	7-6	Load-Shed Settings .....	A-9
To Connect/Disconnect Charger .....	7-6	<b>Index</b> .....	<b>I-11</b>
Voltage Control .....	7-7		
Manual Switch Operation			
DD-29-P,R,S,T,U,V,W,X,Y .....	7-8		
Transfer Mode Selector			
Switch DD-29 .....	7-8		

# Safety Precautions and Instructions

A transfer switch, like any other electromechanical device, can pose potential dangers to life and limb if improperly maintained or imprudently operated. The best way to prevent accidents is to be aware of the potential dangers and to always use good common sense. In the interest of safety, some general precautions relating to operating of a transfer switch follow. Below are some general precautions relating to the operation of a transfer switch. **SAVE THESE INSTRUCTIONS.**

## **DANGER**

Danger indicates the presence of a hazard that will cause severe personal injury, death, or substantial property damage if the danger is ignored.

## **WARNING**

Warning indicates the presence of a hazard that can cause severe personal injury, death, or substantial property damage if the warning is ignored.

## **CAUTION**

Caution indicates the presence of a hazard that will or can cause minor personal injury or property damage if the caution is ignored.

## **NOTE**



Note communicates installation, operation, or maintenance information that is important but not hazard related.

Safety decals are affixed to the generator set in prominent places to advise the operator or service technician of potential hazards. The decals are reproduced here to improve operator recognition. For a further explanation of decal information, refer to the safety precautions throughout this manual. Before operating or servicing the generator set, be sure you understand the messages of these decals. Replace decals if missing or damaged.

# Accidental Starting

**Accidental starting can cause severe injury or death.** Turn generator set master switch to OFF position, disconnect power to battery charger, and remove battery cables (remove negative lead first and reconnect it last) to disable generator set before working on any equipment connected to generator set. The generator set can be started by automatic transfer switch or remote start/stop switch unless these precautions are followed.

# Battery

 <b>WARNING</b>

<p><b>Explosion.</b> <b>Can cause severe injury or death. Relays in battery charger cause arcs or sparks.</b></p> <p>Locate in a well-ventilated area. Keep explosive fumes away.</p>

**Explosion can cause severe injury or death.** Battery gases can cause an explosion. Do not smoke or permit flame or spark to occur near a battery at any time, particularly when it is being charged. Avoid contacting terminals with tools, etc., to prevent burns and sparks that could cause an explosion. Remove wristwatch, rings, and any other jewelry before handling battery. Never connect negative (-) battery cable to positive (+) connection terminal of starter solenoid. Do not test battery condition by shorting terminals together. Sparks could ignite battery gases or fuel vapors. Ventilate any compartment containing batteries to prevent accumulation of explosive gases. To avoid sparks, do not disturb battery charger connections while battery is being changed. Always turn battery charger off before disconnecting battery connections. Remove negative lead first and reconnect it last when disconnecting battery.

---

## **WARNING**





**Sulfuric acid in batteries.**  
**Can cause severe injury or death.**

Use protective goggles and clothes. Battery acid can cause permanent damage to eyes, burn skin, and eat holes in clothing.



---

**Sulfuric acid in batteries can cause severe injury or death.** Sulfuric acid in battery can cause permanent damage to eyes, burn skin, and eat holes in clothing. Always wear splash-proof safety goggles when working around the battery. If battery electrolyte is splashed in the eyes or on skin, immediately flush the affected area for 15 minutes with large quantities of clean water. Seek immediate medical aid in the case of eye contact. Never add acid to a battery once the battery has been placed in service. This may result in hazardous spattering of electrolyte.



# Hazardous Voltage/ Electrical Shock

 <b>WARNING</b>

<p><b>Hazardous voltage. Can cause severe injury or death.</b></p> <p>Disconnect power sources before servicing. Barrier must be installed after adjustments, maintenance, or servicing.</p>

*(under 600 Volt)*



 <b>WARNING</b>

<p><b>Hazardous voltage. Can cause severe injury or death.</b></p> <p>Do not open enclosure until all power sources are disconnected.</p>

*(under 600 Volt)*

 <b>DANGER</b>

<p><b>Hazardous voltage. Will cause severe injury or death.</b></p> <p>Do not open enclosure until all power sources are disconnected.</p>

*(600 Volt and above)*

**Hazardous voltage can cause severe injury or death.** Disconnect inner panel harness at in-line connector. This will de-energize circuit board and logic circuitry, but allow transfer switch to continue to supply utility power to necessary lighting and equipment. Hazardous voltage will exist if any accessories mounted to inner panel are NOT wired through and de-energized by harness separation. Such accessories may be at line voltage.

 <b>DANGER</b>

<p><b>Hazardous voltage. Will cause severe injury or death.</b></p> <p>Disconnect power sources before servicing. Barrier must be installed after adjustments, maintenance, or servicing.</p>

*(600 Volt and above)*

**Hazardous voltage can cause severe injury or death.** Short circuits can cause bodily injury and/or equipment damage. Do not contact electrical connections with tools or jewelry while adjustments are made. Remove wristwatch, rings, and jewelry that can cause short circuits.

**Hazardous voltage can cause severe injury or death.** To prevent the possibility of electrical shock, disconnect harness plug before installing any accessories involving connection to transformer assembly primary terminals on microprocessor logic models. Terminals are at line voltage!

**Hazardous voltage can cause severe injury or death.** Keep unauthorized persons away from the generator set and take precautions to prevent unqualified personnel from tampering with the transfer switch. Have the generator set and electrical circuits serviced only by qualified technicians. Wiring should be inspected at the recommended interval shown in the service schedule—replace leads that are frayed or in poor condition. Do not operate electrical when standing in water or on wet ground.

**Hazardous voltage can cause severe injury or death.** Short circuits can cause bodily injury and/or equipment damage. Do not contact electrical connections with tools or jewelry while adjustments are made. Remove wristwatch, rings, and jewelry that can cause short circuits.

**NOTE**

**When replacing hardware, do not substitute with inferior grade hardware.** Screws and nuts are available in different hardness ratings. American Standard hardware uses a series of markings and metric hardware uses a numeric system to indicate hardness. Check markings on bolt head and nuts for identification.

**NOTE**

**Hardware Damage!** Transfer switch may use both American standard and metric hardware. Use the correct size tools to prevent rounding of bolt heads and nuts.

**NOTE**

Perform these checks in the order given to avoid damaging the switch.

**NOTE**

These battery chargers are designed strictly for use in this transfer switches and conform with UL and CSA listing requirements where specified. Do not attempt to use battery charger before reading instructions.

**NOTE**

Connect source and load phases as indicated by the markings and drawings. Improper connections may cause short circuits and can cause phase-sensitive load devices to run in reverse or prevent load devices from functioning.

**NOTE**

**CHARGER DAMAGE!** Connect charger only to a battery with the same DC voltage as the battery charger output rating.

# Introduction

This manual provides operation and initial installation instructions for Kohler® automatic transfer switches that use the M340+ logic controller.

Read through this manual and carefully follow all procedures and safety precautions to ensure safe, reliable operation of your automatic transfer switch. Keep a copy of this manual with the automatic transfer switch for future reference.

All information found in this publication is based on data available at time of printing. The manufacturer reserves the right to make changes to this literature and the products represented at any time without notice and without incurring obligation.

## List of Related Materials

The group of power switching devices covered by this manual are part of a family of related devices. Separate operation and installation manuals are available for each group within the overall family. Be sure this manual is the correct manual for the automatic transfer switch.

A power conversion unit is included in each automatic transfer switch. There are various types of power conversion units and each type is covered in a separate operation and installation manual. To be complete, the automatic transfer switch operation and installation manual must be accompanied by a copy of the operation and installation manual for the power conversion unit used in that automatic transfer switch.

### NOTE

All wiring diagrams and installation instructions are included in the power conversion unit's operation and installation manual.

Available power conversion units and the related manual numbers are as follows.

Power Switching Device	Operation/ Installation Manual
Model MMS/MNS 40-1250 amp molded-case circuit breakers or switches	TP-5658
Model ZCS 40-3000 amp contactor, standard or with programmed transition	TP-5660
Model ZCB 100-3000 amp bypass-isolation switch	TP-5665
Model TLS/TES 25-400 amp mechanically or electrically held contactors	TP-5659
Model MMS/MNS 1600-4000 amp molded-case circuit breakers or switches	TP-5678
Model MMT/MNT 40-1250 amp molded-case circuit breakers or switches	TP-5973

Transfer switches with microprocessor electrical controls and communication accessories can be monitored and controlled with a personal computer and software. The following table lists the available manuals and part numbers.

Communication Item	Operation/ Installation Manual
Remote Monitoring and Control Communication Software DOS Win 95/98/NT	TP-5823 TP-5972
Controller Communication Kits	TT-847

# Service Assistance

For service or information, consult the yellow pages of the telephone directory under the heading GENERATORS-ELECTRIC for the Authorized Kohler Service Distributor/Dealer.

KOHLER CO., Kohler, Wisconsin 53044  
 Phone 920-565-3381  
 Fax 920-459-1646 (North American Sales)  
 920-459-1614 (International Sales)  
 For Sales and Service in U.S.A. and Canada  
 Phone 1-800-544-2444

In communications regarding the automatic transfer switch, please include the PART and SERIAL numbers provided on the nameplate attached to the transfer switch. Enter the numbers in the spaces provided below. This information will enable the authorized Kohler service distributor/dealer to supply the correct part or information for your particular model.

Part No. \_\_\_\_\_

Serial No. \_\_\_\_\_

# Notes

# Section 1. Specifications

## Purpose of Switch

An Automatic Transfer Switch (ATS) is a device used for transferring critical electrical loads from a normal (preferred) source of electrical power to an emergency (standby) source. This transfer occurs automatically when the normal source voltage fails, or is substantially reduced, and the emergency sources voltage has reached an acceptable level.

Upon normal source failure, the automatic transfer switch controller signals the generator set(s) to start,

and transfers to the emergency source. The automatic transfer switch controller continuously senses for an acceptable normal source and will retransfer the load to the normal source after it has been restored to an acceptable level. After retransfer of the load, the generator set start signal is removed and the generator set(s) are allowed to shut down.

## Components of Switch

A typical automatic transfer switch includes the actual power switching device and the logic controller to perform power monitoring and transfer sequencing tasks. See Figure 1-1. An interface board is also included to match the controller inputs/outputs to the levels required by a specific switching device.

The three functional units that make up the automatic transfer switch are mounted in an enclosure with a hinged front door. The controller mounts on the back of the front door so its controls and indicators are available to an operator. A signal cable with in-line connectors to facilitate component replacement and door removal connects the controller to the interface board and the switching devices.

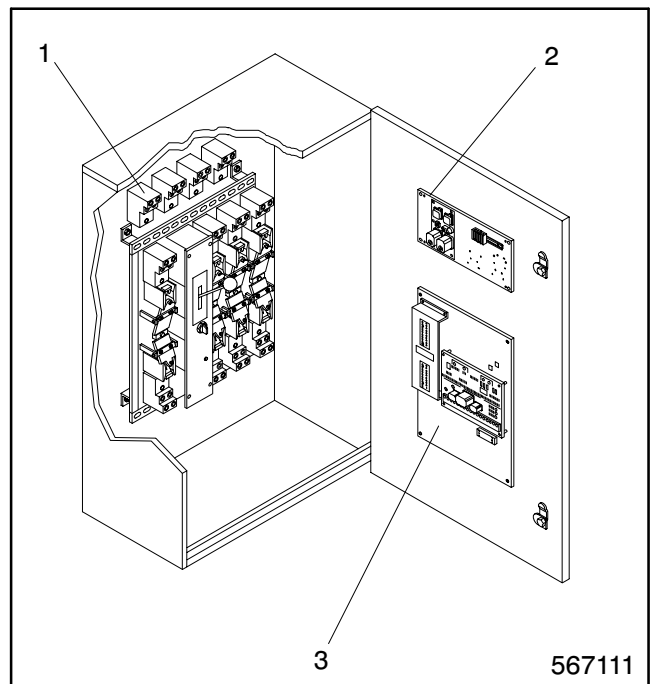

1. Power conversion unit
2. Interface panel
3. Logic controller

**Figure 1-1. Transfer Switch Components**

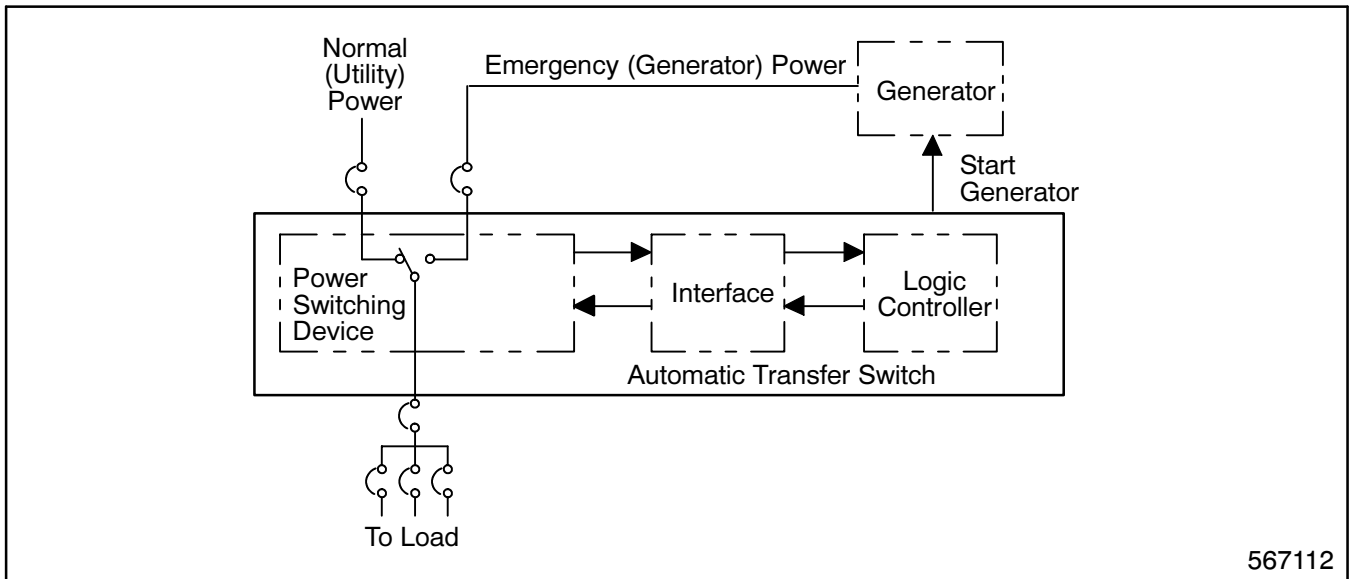

**Figure 1-2. Basic Transfer Switch Block Diagram**

## Ratings

A nameplate is attached to the automatic transfer switch enclosure. See Figure 1-3. The nameplate label includes a factory part number coded to provide characteristic and rating information that affects installation and operation. Copy the part number into the blank spaces provided in Figure 1-4 and then use the tables in Figure 1-4 to interpret the part number.

### NOTE

Also copy the part number and serial number from the nameplate into the spaces provided in the Service Assistance Section of the Introduction for use when requesting service or parts.

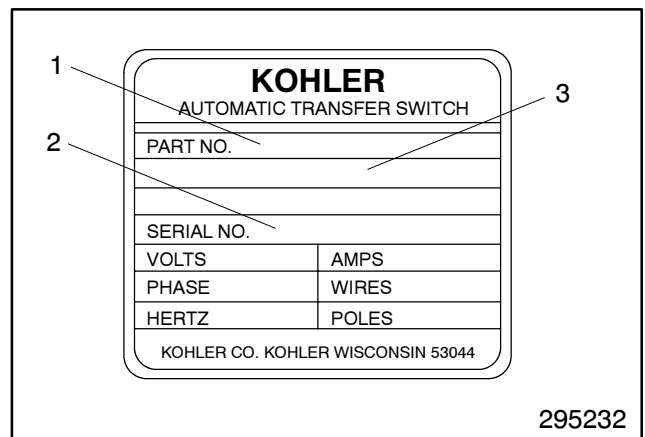

1. Part number model code
2. Serial number
3. Factory-installed accessories

**Figure 1-3. Transfer Switch Nameplate**

# Interpreting a Transfer Switch Part Number

Record the transfer switch part number in the boxes below. The transfer switch part number defines characteristics and ratings as explained in the accompanying chart.

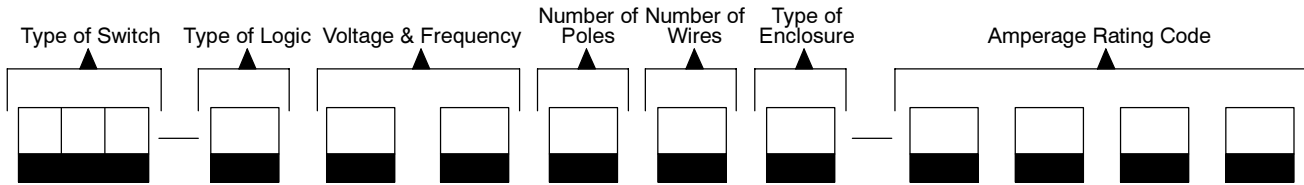

## Kohler® Part Number Key

This chart explains the Kohler® transfer switch part numbering code system. The sample part number shown is for a standard molded-case switch with M340+ logic rated at 480 volts, 60 hertz, 3-phase, 3-pole, and 4 wires in a NEMA 1 enclosure with an amperage rating of 80 amperes.

## SAMPLE PART NUMBER

**MNS-566341-0080**

### Classification of Power Switch

M: Molded-case circuit breaker or switch  
 T: Electrically or mechanically held contactor  
 Z: Contactor

### Type of Power Switch

C: Contactor  
 E: Electrically held contactor  
 L: Mechanically held contactor  
 M: Molded-case circuit breaker  
 N: Molded-case switch (no protection)

### Type of Switch

S: Standard                      T: Standard  
 B: Bypass

### Type of Logic

5: M340+  
 6: M340+ with programmed transition

### Voltage Code

60: 600 Volt, 60 Hz              66: 480 Volt, 60 Hz  
 62: 120 Volt, 60 Hz            68: 208 Volt, 60 Hz  
 63: 220 Volt, 50 Hz            71: 380 Volt, 50/60 Hz  
 64: 240 Volt, 60 Hz

### Number of Poles

2: 2 pole, 1 phase (MM\_, MN\_, TE\_, TL\_, devices are supplied with 3 poles)  
 3: 3 pole, 3 phase  
 6: 4 pole, fully rated switched poles (no overlapping neutral)

### Number of Wires

2: 2 wire                      3: 3 wire                      4: 4 wire

### Enclosure

1: NEMA type 1

### Amperes

Available sizes vary with the type of switch.

Figure 1-4. Transfer Switch Model Description

# Specifications

## Standard Features

- Normal source voltage sensing adjustable from 72% to 100% of normal for pickup and from 70% to 98% for dropout; provides monitoring line-to-line for all phases of 3-phase switches.
- TDNE (Time Delay Normal-to-Emergency) adjustable 0 to 5 minutes.
- TDES (Time Delay Engine Start) adjustable from 0 to 6 seconds.
- TDEN (Time Delay Emergency-to-Normal) adjustable 0 to 30 minutes.
- TDEC (Time Delay Engine Cooldown) adjustable from 0 to 30 minutes.
- Generator engine start contacts.
- Indicators for switch position—normal and emergency.
- Indicators for source available—normal and emergency.
- Lamp test switch, momentary.
- Underfrequency sensing—one phase emergency source only.
- Main shaft auxiliary contacts—one closed on normal and one closed on emergency. Available on certain power switching mechanisms.
- LCD digital voltmeter.
- LCD digital running time meter.
- LCD digital transfer counter.
- LCD digital frequency meter.
- Status panel with keypad data entry.
- Area protection with override.

**Area protection** is used to turn on the emergency source in the event that a loss of the normal power is expected due to an approaching storm or for some other reason. Area protection allows the user of the transfer switch to transfer the load to the emergency source or area protection can be enabled by disconnecting TB-DC1-6 from TB-DC1-33. Doing this turns on the area protection LED. Once this wire is disconnected, the controller will start the generator and transfer to the emergency source until TB-DC1-6 is reconnected to TB-DC1-33.

# Shunt/Jumper-controlled Accessories

These options are shunt controlled and are enabled or disabled by only altering JP1 on the main logic board. See Figure 1-5. All shunt-jumper features are disabled from the factory unless the function was ordered at the time of purchase.

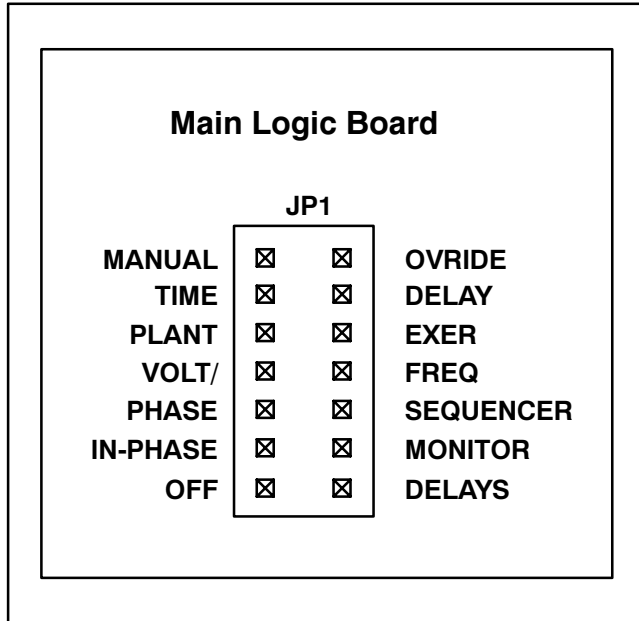

**Figure 1-5. Logic Board Accessory Programming Shunts**

- Inphase Monitor.** Motors and related equipment can be damaged by abnormal inrush currents when switched between two live power sources. The purpose of the inphase monitor is to minimize abnormal inrush currents to equipment when the equipment is connected to a new power source. The inphase monitor samples a single phase of one source and compares it to a single phase of the

other source. When the two voltages are within the desired phase angle and approaching a zero phase angle difference, the inphase monitor signals the transfer switch to operate. The transfer may be from utility to generator, from generator to generator, or utility to utility. This option is available only on contactor type, non-programmed transition switches. If the contactor is not of this type, then the controller will not allow this option to be enabled. To enable this option, the INPHASE MONITOR jumper must be installed on the controller's main logic board.

- Phase Rotation and Anti-Single Phasing.** This function provides source monitoring for both the normal and emergency sources. The feature includes phase rotation, and anti-single phase protection. This option must be used in conjunction with DD-05-K in order to provide source monitoring on the emergency side. This accessory can be enabled by installing the PHASE SEQUENCER jumper on the controller's main logic board.
- Normal and Emergency Source Sensing.** This function provides overvoltage sensing on all phases of the normal source, over/underfrequency sensing on one phase of the normal source, overvoltage sensing on one phase of the emergency source, and overfrequency sensing on one phase of the emergency source. This accessory can be enabled by installing the VOLT/FREQ jumper on the controller's main logic board.
- Plant Exerciser.** This function enables a no-load plant exerciser with override. User has a choice of 7-day, 14-day, or calendar-based exercise modes. This accessory can be enabled by installing the PLANT EXER jumper on the controller's main logic board.

- **Extended Time Delay.** This function extends the time delay to 99 minutes for TDNE, TDES, TDEN, TDOE, TDON, and TDEC. This accessory can be enabled by installing the TIME DELAY jumper on the controller's main logic board.
- **Off Delay.** This function enables the programmed transition feature. This feature allows the contactor to be in an off position for a predetermined amount of time. See Section 7 Index 5 for information about programming the programmed transition time delays. The controller determines if the off position time delays are available for the switch it is connected to. If it is available, then the jumper will determine if the off position delays are enabled (jumper in) or disabled (jumper out).

**NOTE**

On a molded-case circuit breaker/switch transfer switch the off position is required and the jumper has no effect on the delays.

## Optional Accessories

See Section Accessories for details of optional accessories. The nameplate includes a list of the accessories selected. See Figure 1-3.

- Emergency source overfrequency sensing 1 phase, over/undervoltage sensing three phase
- Two-position test switch: AUTO, TEST
- Three-position test switches: TEST, AUTO, ENGINE START
- Four-position test switch: TEST, AUTO, OFF, ENGINE START
- Time delay override switch: TDNE, TDEN
- Contactor position—auxiliary contacts
- Meters: frequency, voltage and ammeter, analog
- Plant exercise—7-day, 14-day or calendar, load/no-load selectable
- Battery charger, 2-ampere float, 12 volt
- Battery charger, 2-ampere float, 24 volt
- Manual switch operation with override
- Load-shedding contacts
- Remote communication—RS-232, RS-485

# Section 2. Operation

## Control Switches and Indicators

Various optional control switches and indicator lamps may be present on the transfer switch door depending

on the options chosen. See Figure 2-1 for LED, Switch, and Key locations.

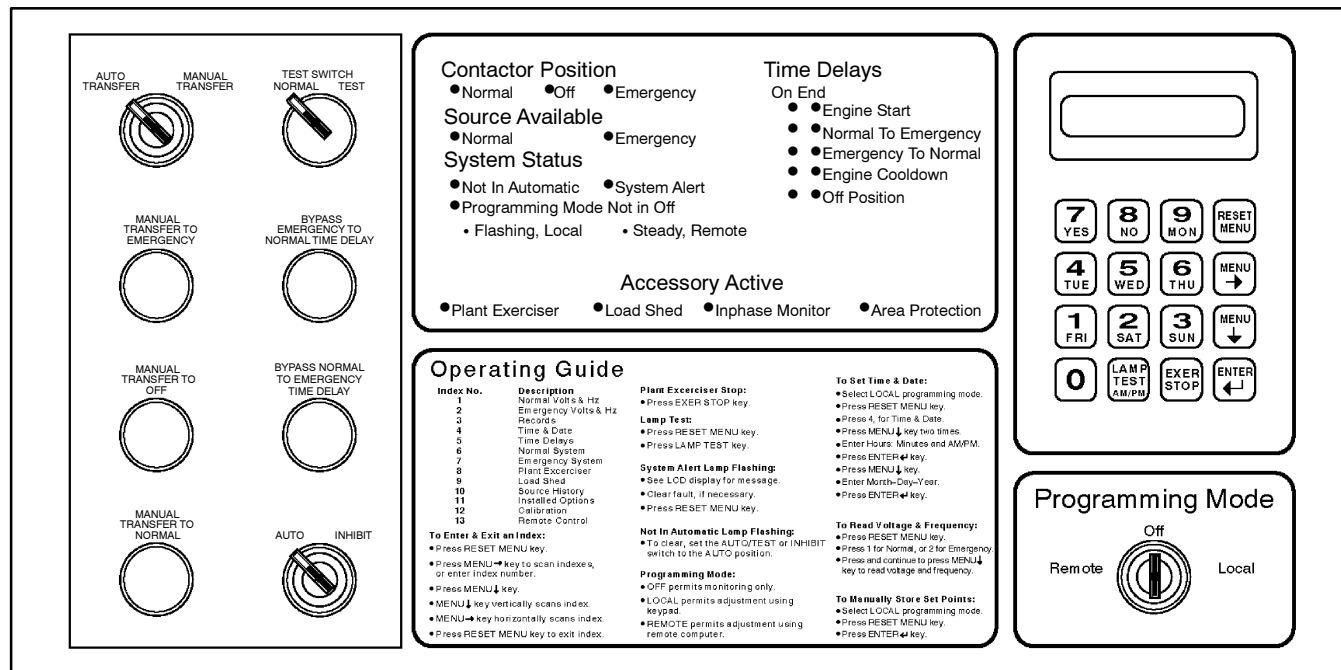

Figure 2-1. Front Panel

### LED Indicators

**Contactor Position.** LEDs indicate transfer switch position—Normal (green), Emergency (red), or Off (yellow).

**Source Available.** LEDs indicate source with acceptable voltage and frequency—Normal (green) and/or Emergency (red).

### System Status

**Not in Automatic** (red). LED flashes to show that Test switch is actuated, or Auto/Manual switch is in the Manual position.

**System Alert** (red). LED flashes to show possible problem with contactor or logic operation. System alert will also flash if any auxiliary signals are received from the generator set.

**Programming Mode Not in Off** (yellow). LED flashes to show that programming switch is in the Local position. A steady, nonflashing light shows that the programming switch is in the Remote position.

## Time Delays

**Engine Start** (If emergency source is a generator set). ON LED indicates that engine-start time delay is timing. END LED indicates that the engine has been signaled to start.

**Normal to Emergency.** ON LED indicates that the normal-to-emergency time delay is timing. END LED indicates that the time delay has completed timing.

**Emergency to Normal.** ON LED indicates that the emergency to normal time delay is timing. END LED indicates that the time delay has completed timing.

**Engine Cooldown.** ON LED indicates that the generator set engine cooldown timer is timing. END LED illuminates until the engine has shut down.

**Off Position.** ON LED indicates that the time delay off position is timing. END LED indicates that the time delay has completed timing.

## Accessory Active

**Plant Exerciser.** Plant exerciser LED indicates that the system exerciser is operating.

**Load Shed.** Load shed LED indicates that programmed load shedding is active.

**Inphase Monitor** (available on ZC type power switches only). Inphase monitor LED indicates that the sources are being monitored for phase relationship to allow inphase transfer. The inphase monitor will permit transfer from emergency to normal and normal to emergency when sources are near synchronization.

## NOTE

When a programmed transition switch is ordered, the inphase monitor option is disabled by the microprocessor.

**Area Protection.** Area protection LED indicates that the controller is in the area protection mode. The generator will be signaled to START and the contactor will transfer to the emergency position and remain there while in area protection.

## Programming Mode Switch

### NOTE

The programming mode switch keys should be kept in a safe place to prevent unwanted tampering with the transfer switch control. Do *not* leave the programming switch in the LOCAL position with the transfer switch unattended.

**Remote.** Allows both status monitoring and setting of the transfer switch controls by a connected personal computer.

**Off.** Transfer switch status settings and power source may be monitored from the local LCD display or connected computers.

**Local.** Allows both status monitoring and setting of transfer switch control from the microprocessor's LCD display and keypad.

# Control Switches

**Test Switch.** Moving the test switch to the TEST position will simulate a normal source outage. Not-in-Automatic system status light will flash.

**Bypass N-E Time Delay Pushbutton Switch.** If the bypass normal-to-emergency time delay pushbutton is pressed when normal-to-emergency time delay is on, time delay will end.

**Bypass E-N Time Delay Pushbutton Switch.** If the bypass normal-to-emergency time delay pushbutton is pressed, when emergency-to-normal time delay is on, time delay will end.

**Manual Transfer to Emergency Switch.** When the transfer switch control is in the manual mode of operation and manual to emergency is requested, pressing the manual transfer-to-emergency pushbutton

will cause the transfer switch to transfer to the emergency position.

**Manual Transfer to Off Switch.** When the transfer switch control is in the manual mode of operation and manual to off is requested, pressing the manual transfer-to-emergency pushbutton will cause the transfer switch to transfer to the off position.

**Manual Transfer to Normal Switch.** When the transfer switch control is in the manual mode of operation and manual to normal is requested, pressing the manual transfer-to-emergency pushbutton will cause the transfer switch to transfer to the normal position.

**Auto/Inhibit Switch.** If the auto/inhibit switch is in the AUTO position, the transfer switch will operate normally. If the switch is in the Inhibit position, the transfer switch will not transfer under any conditions.

# Sequence of Operation

This section describes the correct operation of a microprocessor controlled transfer switch.

## Sequence of Operation Standard Switch

### When the Normal Source Fails

1. The source-available, normal LED turns off.
2. The time-delay-engine-start ON LED will turn on indicating the engine-start-time-delay is timing.
3. The time-delay-engine-start END LED will turn on indicating the engine has been signaled to start.
4. The source-available emergency LED turns on.
5. The time-delay normal-to-emergency ON LED will turn on indicating the normal-to-emergency time delay is timing.
6. The time-delay normal-to-emergency END LED will turn on indicating the time delay has completed timing.
7. The load-shed LED turns on at the same time all loads to be shed are disconnected from the switch (if equipped with load-shed option).
8. The inphase monitor LED turns on (if equipped with inphase monitor option on ZC type power switches only). The controller monitors the two voltages to make sure they are at a desired phase angle and approaching zero phase angle difference.
9. The contactor transfers to the emergency position after the load-shed time-before-transfer timer has completed timing. The contactor-position normal LED turns off and the contactor-position emergency LED turns on. The inphase monitor LED turns off.
10. After the load-shed time-after-transfer timer has completed timing, the selected loads for the emergency source are now returned to the switch. The load-shed LED turns off (if equipped with load-shed option).

## When the Normal Source Returns

1. The source-available, normal LED turns on.
2. The time-delay emergency-to-normal ON LED will turn on indicating the emergency-to-normal time delay is timing.
3. The time-delay emergency-to-normal END LED will turn on indicating the time delay has completed timing.
4. The load-shed LED turns on at the same time all loads to be shed are disconnected from the switch (if equipped with load-shed option).
5. The inphase monitor LED turns on (if equipped with load-shed option).
6. The contactor transfers to the normal position after the load-shed time-before-transfer timer has completed timing. The contactor-position emergency LED turns off and the contactor-position normal LED turns on.
7. After the load-shed time-after-transfer timer has completed timing, the selected loads for the normal source are now returned to the switch. The load-shed LED turns off (if equipped with load-shed options).
8. The time-delay engine-cooldown ON LED turns on indicating the generator set engine cooldown timer is timing.
9. The time-delay engine-cooldown END LED stays on until the generator has shut down.
10. The source-available, emergency LED turns off.

# Microprocessor-Controlled Transfer Logic Standard Switch

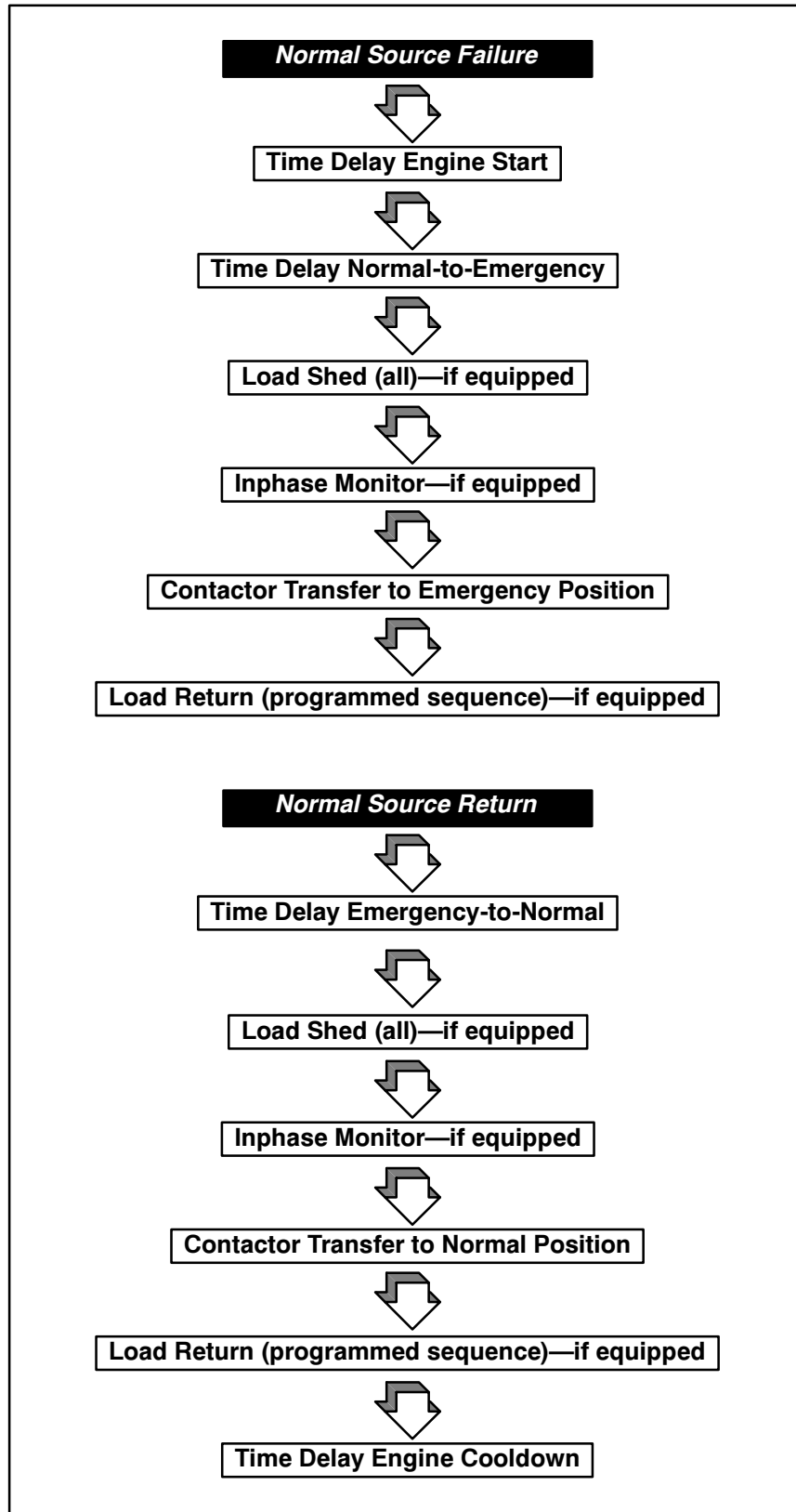

# Sequence of Operation Programmed Transition Switch

## When the Normal Source Fails

### NOTE

When a programmed transition switch is ordered, the inphase monitor option is disabled by the microprocessor.

1. The source-available, normal LED turns off.
2. The time-delay-engine-start ON LED will turn on indicating the engine-start-time-delay is timing.
3. The time-delay-engine-start END LED will turn on indicating the engine has been signaled to start.
4. The source-available emergency LED turns on after the generator is at rated voltage and frequency.
5. The time-delay normal-to-emergency ON LED will turn on indicating the normal-to-emergency time delay is timing.
6. The time-delay normal-to-emergency END LED will turn on indicating the time delay has completed timing.
7. The load-shed LED turns on at the same time all loads to be shed are disconnected from the switch (if equipped with load-shed option).
8. After the load-shed time-before-transfer timer has completed timing, the contactor transfers to the Off position. The contactor-position normal LED turns Off and the contactor-position Off LED turns On.
9. The time-delay-off-position ON LED will turn on indicating the Off position time delay is timing.
10. The time-delay-off-position END LED will turn on indicating the time delay has completed timing.
11. The contactor transfers to the emergency position. The contactor-position Off LED turns off and the contactor-position emergency LED turns on.
12. After the load-shed time-after-transfer timer has completed timing, the selected loads for the emergency source are now returned to the switch. The load-shed LED turns off (if equipped with load-shed option).

## When the Normal Source Returns

1. The source-available, normal LED turns on.
2. The time-delay emergency-to-normal ON LED will turn on indicating the emergency-to-normal time delay is timing.
3. The time-delay emergency-to-normal END LED will turn on indicating the time delay has completed timing.
4. The load-shed LED turns on at the same time all loads to be shed are disconnected from the switch (if equipped with load-shed option).
5. After the load-shed time-before-transfer timer has completed timing, the contactor transfers to the Off position. The contactor-position emergency LED turns off and the contactor-position Off LED turns on.
6. The time-delay off-position ON LED will turn on indicating the off-position-time-delay is timing.
7. The time-delay off-position END LED will turn on indicating the time delay has completed timing.
8. The contactor transfers to the normal position. The contactor-position OFF LED turns off and the contactor-position normal LED turns on.
9. After the load-shed time-after-transfer timer has completed timing, the selected loads for the normal source are returned to the switch. The load-shed LED turns off (if equipped with load-shed option).
10. The time-delay-engine-cooldown ON LED turns on indicating the generator set engine cooldown timer is timing.
11. The time-delay-engine-cooldown END LED stays on until the generator has shut down.
12. The source-available emergency LED turns off.

# Microprocessor-Controlled Transfer Logic Programmed Transition Switch

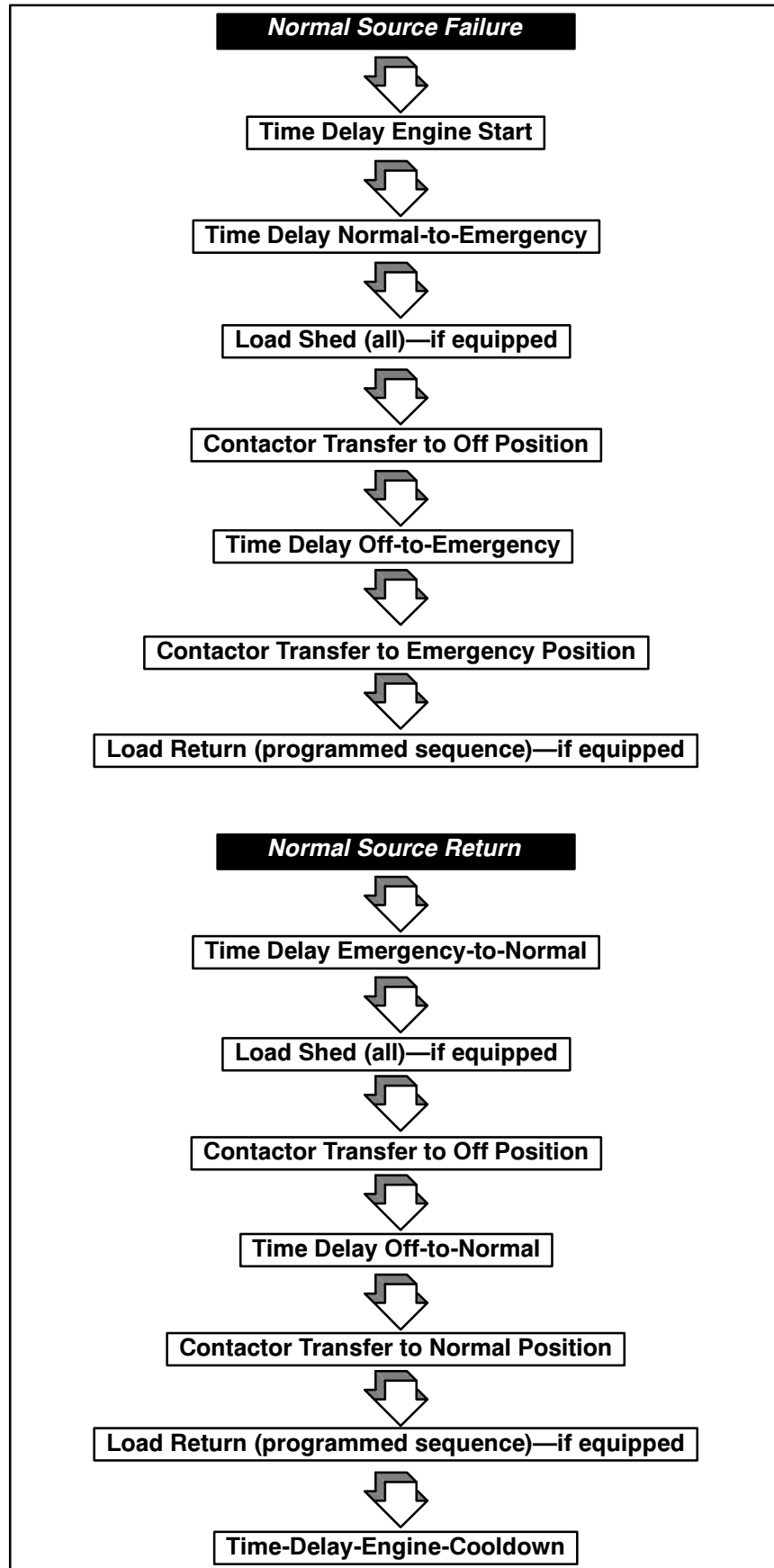

# Notes

# Section 3. Programming Information

## General Programming Information

The user interacts with the microprocessor controller by a keypad and a liquid crystal display (LCD). In discussing the programming of the controller, the user must be familiar with the keypad (hardware) and the messages or symbols that appear on the LCD screen (software). See Figure 3-1. Below is a brief description of the function of the hardware and the software prompts.

### Hardware

**Programming Mode Switch:** The Programming Mode Switch is used to select the input method that the controller uses to accept new set points. The three modes and their functions are described below:

**Off:** Transfer switch status settings and power source may be monitored from the LCD display or connected computers. Settings cannot be changed when the programming switch is in the OFF position.

**Local:** Allows both status monitoring and setting of transfer switch control from the LCD display and keypad. The transfer switch may be monitored by computer.

**Remote:** Allows both status monitoring and setting of the transfer switch controls by a directly or remotely connected personal computer. Computer(s) may be singly connected to the transfer switch or connected through area networks. Allows monitoring at the transfer switch.

**Keypad:** The keypad is used to input information into the controller. Some keys have dual functions. The function(s) of the keys are listed below:

**Number Keys:** If the controller is asking a question that requires a numeral answer, the controller will automatically accept the number of the key that is pressed and ignore the second function of the key.

**Number Key Second Function:** If the controller is asking a question that requires an answer that is nonnumeric (Yes, No, Weekday), the controller will automatically accept the second function of the key that is pressed and ignore the numeral of the key.

**Menu ↓ Key:** The software for the controller is set up in indexes. Inside each of these indexes there are several layers of programming steps. The menu ↓ key moves from layer to layer inside of each index. The program is set up as a scrolling display so if the menu ↓ key is pressed repeatedly, eventually the display will repeat each step in the index.

**Menu ➡ Key:** Within the layers of the indexes, there may be more than one action required. The LCD will display an arrow in the right-hand corner of the display indicating that there are more items to be inputted at this layer. Pressing the menu ➡ key when the arrow is not displayed will not affect the program.

**Reset Menu Key:** This key resets the program back to the beginning. The Reset Menu key can be used to exit an index or any layers within that index.

**Enter Key:** This key is used to input the information that is on the screen into the controller’s memory.

**Exer Stop Key:** Pressing this key will end a generator’s exercise run. The transfer switch will transfer to normal (if the generator set is being exercised under load) and the generator set will continue running through its time-delay engine-cooldown period before shutting down.

**Lamp Test Key:** Pressing the lamp test key will illuminate the LEDs on the status panel and black out the LCD display screen. See Figure 3-2.

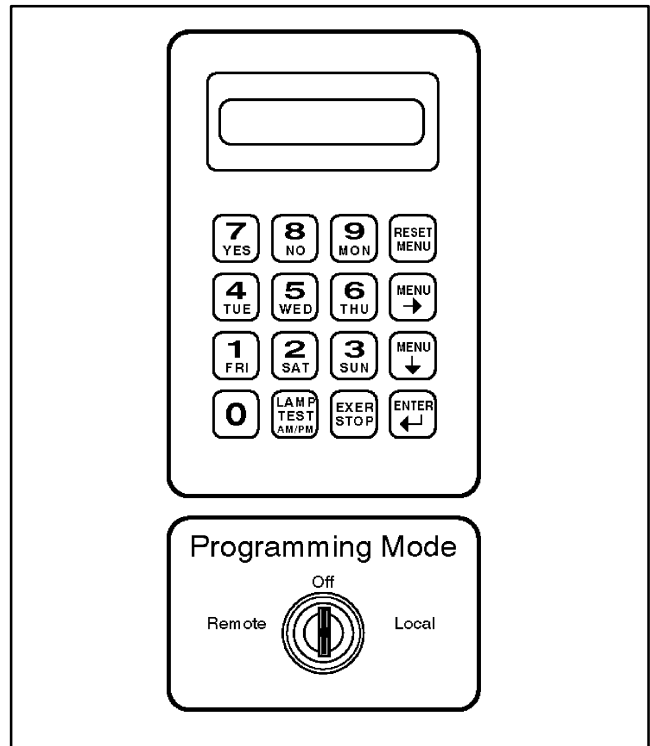
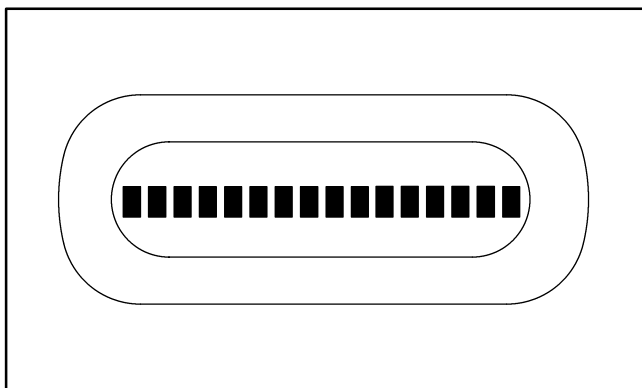

**Figure 3-1. M340+ Keypad and Programming Mode Switch**

# Software

## Display Notes

- ↓ Directs users to the next screen. Press the down arrow to scroll through the layers and loop back to first screen. Press the down arrow key after Index 13 to return back to Index 1. The ↓ symbol tells the user that there are more layers within the index.
- ➡ Indicates that there are more to the right. Press the right arrow key to view these. These are also looping. Press the down arrow key to move to the next layer in the index.
- ? The controller is asking a question. Answer with the Yes or No key or use a digit, day, or AM/PM key.



**Figure 3-2. The LCD During a Lamp Test**

**Index Number:** The index number is used to select the area of the program that the user would like to view or

program. For example: Index 6 is used for programming or viewing, depending on the position of the programming mode switch, normal source voltage, and frequency.

**Entry Accepted:** This message indicates that the information that was entered has been accepted by the controller.

**Store Setpoints:** Shows that control settings are stored in memory. Pressing the RESET MENU and the ENTER keys simultaneously after entering settings will store the new setpoints.

**Range Error:** The range error message indicates that the entered response is outside of the acceptable input range for that program parameter.

**Check Key Switch:** Shows that a setting or setup entry has been attempted with the programming mode switch in the OFF or REMOTE position.

**Set Time and Date:** Shows when the time and date (Index 4) need to be set.

**Pickup Adjusted:** Shows that the setting has been entered and the related pickup or dropout setting has been automatically adjusted to maintain the required 2% difference.

**Disabled:** Shows that the particular option is not enabled by the main circuit board jumper.

For system alert message definitions, see Appendix C.

# Notes

# Section 4. Programming Switch Off Mode

## Index List

This is a list of the monitoring menus used when the programming switch is the OFF mode. The index number associated with each menu is used to gain access to the layers under that area. Reviewing these menus will familiarize the user with the keypad functions and the LCD display.

- **Index 1, Normal Voltage and Frequency (NORMAL VOLT and FREQ.)** Index 1 displays actual normal source voltage, frequency, and phase sequence.
- **Index 2, Emergency Voltage and Frequency (EMER VOLT and FREQ.)** Index 2 displays actual emergency source voltage, frequency, and phase sequence.
- **Index 3, Operational Records (RECORDS ACTUAL, RECORDS MAINTENANCE.)** Index 3 contains two sets of records: ACTUAL and MAINTENANCE. ACTUAL records are cumulative since initial controller setup. MAINTENANCE records are those kept by the controller since the last time it was reset.
- **Index 4, Clock, Day, and Calendar (TIME, DATE, DAY.)** Index 4 displays time, date, day, and days occurrence number (1-5) in the present month.
- **Index 5, Time Delays (TIME DELAY MN:SE.)** Index 5 displays time delay settings associated with ON-END LEDs on the front panel.
- **Index 6, Normal Voltage and Frequency Settings and Trip Points (NORMAL SYSTEM.)** Index 6 displays normal-source trip point settings that will initiate a transfer sequence.
- **Index 7, Emergency Voltage and Frequency Settings and Trip Points (EMERGENCY SYSTEM.)** Index 7 displays emergency-source trip point settings that will initiate a transfer sequence.
- **Index 8, Plant Exerciser (PLANT EXERCISER.)** Index 8 displays the exerciser schedule type selections and settings for scheduled days and times.
- **Index 9, Load Shed (LOAD SHED MN:SE.)** Index 9 displays settings for the number of load blocks to be shed and/or returned and the time between each load-shed and/or return signal.
- **Index 10, Source History (SOURCE HISTORY.)** Index 10 displays fault status and summaries describing the four most recent source failures.
- **Index 11, Installed Options (CONTROL OPTIONS.)** Index 11 displays various control options as either enabled or disabled.
- **Index 12, Voltage Calibration (CALIBRATION.)** Index 12 is used to calibrate controller voltage sensing in local programming mode. Contact your local distributor/dealer to calibrate.
- **Index 13, Remote Control Setup (REMOTE CONTROL.)** Index 13 displays connection type and communication settings for monitoring and controlling the transfer switch using a personal computer.

# Index 1—Normal-Source Voltage and Frequency

This index displays the voltage and frequency of the normal source. If phase sequence is enabled it also shows phase sequence for three phase.

Key Entry	Display	Description
	Enter Index 1-13	Controller is waiting for user to input an index number.
	INDEX NUMBER 1	Index 1—Normal-Source Voltage and Frequency
	NORM VOLT & FREQ	Reads actual normal-source voltage, frequency and phase sequence.
	NORM VOLTAGE 000	Normal-source voltage (single-phase shown).
<p><b>NOTE:</b> For single-phase switches both voltage and frequency are on phase A-C. For three-phase switches (with three phase sensing enabled), voltage will be shown for A-B, B-C, and then A-C as the down arrow is pressed.</p>		
	N-FREQ HZ 00.0	Normal-source frequency.
	N-PHA SEQ A-B-C	Three-phase only if phase sequence option is enabled. Proper sequence is A-B-C. B-A-C indicates loss of phase sequence, loss of phase voltage, or incorrect phase sequence.
	ENTER NO. 1-13	Allows a new index number to be entered.

## Index 1—Normal Voltage and Frequency Display Variances Due to Different Option Selections

If single-phase sensing is selected under Index 6, Index 1 display steps will be as follows.

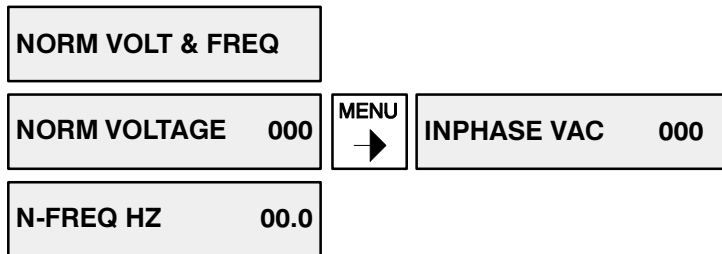

If three-phase sensing is selected under Index 6 and Phase sequence under Index 11 is not enabled, Index 1 display steps will be as follows.

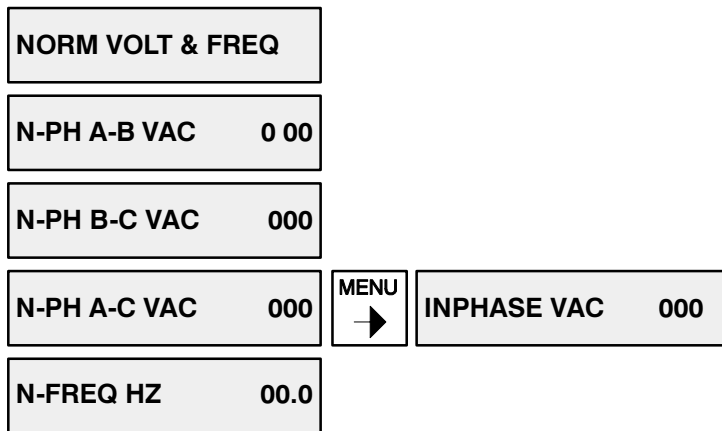

If three-phase sensing is selected under Index 6 and Phase sequence under Index 11 is enabled, Index 1 display steps will be as follows.

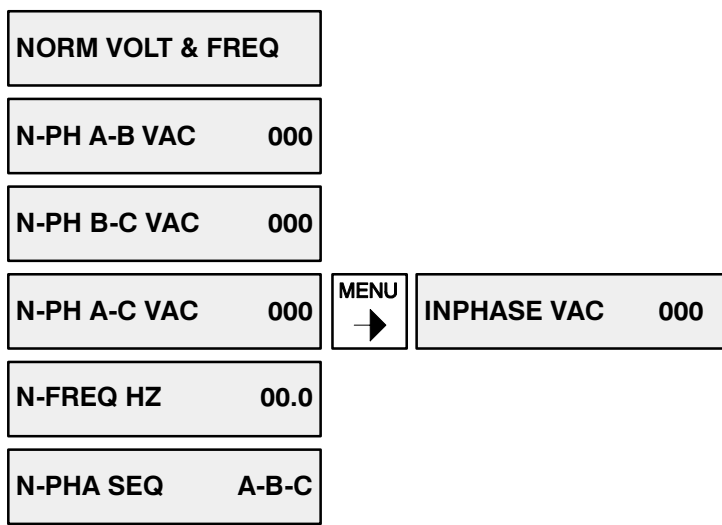

All voltage readings are based on calibrations under Index 12. Voltage and frequency readings are from the system bus. They are compared to entries made in Index 6 to determine normal source availability.







Phase sequence is independent of other indexes. A phase sequence loss will be indicated by B-A-C and will cause the normal source to be unavailable.

## Index 2—Emergency-Source Voltage and Frequency

This index displays the voltage and frequency of the emergency source. It also shows phase sequence for three-phase, if phase sequence is enabled.

**NOTE**

If a generator is used as the emergency source, the display will read 000 for the voltage and frequency unless the generator is running.

Key Entry	Display	Description
	Enter Index 1-13	Controller is waiting for user to input an index number.
	INDEX NUMBER 2	Index 2—Emergency-Source Voltage and Frequency
	EMER VOLT & FREQ	Displays actual emergency-source voltage, frequency and phase sequence.
	EMER VOLTAGE 000	Emergency-source voltage.
	E-FREQ HZ 00.0	Emergency-source frequency.
		<b>NOTE:</b> For single-phase switches, both voltage and frequency are on phase A-C. If three-phase sensing is selected in Index 7, voltage will be shown for A-B, B-C, then A-C as the down arrow is pressed.
	E-PHA SEQ A-B-C	Three-phase only, if enabled. Proper sequence is A-B-C. B-A-C indicates loss of phase sequence, loss of phase voltage or incorrect phase sequence.
	ENTER INDEX. 1-13	Allows a new index number to be entered.

## Index 2—Emergency Voltage and Frequency Displays Variances Due to Different Option Selections

If single-phase sensing is selected under Index 7, Index 2 display steps will be as follows.

EMER VOLT & FREQ

EMER VOLTAGE 000

E-FREQ HZ 00.0

If three-phase sensing is selected under Index 7 and Phase sequence under Index 11 is not enabled, Index 2 display steps will be as follows.

EMER VOLT & FREQ

E-PH A-B VAC 000

E-PH B-C VAC 000

E-PH A-C VAC 000

E-FREQ HZ 00.0

If three-phase sensing is selected under Index 7 and Phase sequence under Index 11 is enabled, Index 2 display steps will be as follows.

EMER VOLT & FREQ

E-PH A-B VAC 000

E-PH B-C VAC 000

E-PH A-C VAC 0 00

E-FREQ HZ 00.0

E-PHA SEQ A-B-C

All voltage readings are based on calibrations under Index 12. Voltage and frequency readings are from the system bus. They are compared to entries made in Index 7 to determine emergency source availability.

Phase sequencer is independent of other indexes. A phase sequence loss will be indicated by B-A-C and will cause the emergency source to be unavailable.

## Program Switch Off Mode

# Index 3—Records, Total and Resettable

This index displays information about the controller's history. The index has two parts within it. One is nonresettable and displays total hours in emergency and the total number of days that the controller has been

energized since factory setup. The second part is a user-resettable section where information can be reset and used for maintenance purposes.

### Key Entry

### Display

### Description

Key Entry	Display	Description
	<b>Enter Index 1-13</b>	Controller is waiting for user to input an index number.
<b>3</b> SUN	<b>INDEX NUMBER 3</b>	Index 3—Records, Total and Resettable
MENU ↓	<b>RECORDS-TOTAL</b>	Total records since factory setup.
MENU ↓	<b>NOT NRM HRS    0000</b>	Total hours with the transfer switch not in the normal position.
MENU ↓	<b>EMER HRS        0000</b>	Total hours with the emergency source available, including exercise periods.
MENU ↓	<b>OPER DAYS       0000</b>	Total days that control has been energized since factory setup.
MENU ↓	<b>TRANSFER #      0000</b>	Total number of transfers in either direction.
MENU ↓	<b>RECORDS-RESET    ▶</b>	Side menu allows user to reset records.
MENU →	<b>RESET RECORD ?   ▶</b>	
MENU ↓	<b>RESET 00-00-00</b>	Date of last record reset.
MENU ↓	<b>NOT NRM HRS      0000</b>	Hours with the transfer switch in the emergency position since last record reset.

Key Entry	Display	Description
MENU ↓	EMER HRS      0000	Hours with the emergency source available since last record reset including exercise periods.
MENU ↓	OPER DAYS      000	Days of operation since last record reset.
MENU ↓	TRANSFER #      0000	Number of transfers since last record reset.
MENU ↓	LAST EXERCISE    ▶	Date of last exercise. Displays last exercise date if exerciser is enabled.
	MENU →    DATE      00-00-00	
RESET MENU	ENTER INDEX. 1-13	Allows a new index number to be entered.

## Program Switch Off Mode

# Index 4—Clock and Calendar

This index is used to view the controller's clock and calendar. The controller uses this information for its exercise feature.

Key Entry	Display	Description
	<b>Enter Index 1-13</b>	Controller is waiting for user to input an index number.
<b>4</b> TUE	<b>INDEX NUMBER 4</b>	Index 4—Clock and Calendar
MENU ↓	<b>TIME 00:00 AM/PM</b>	Current time of day
MENU ↓	<b>DATE 00-00-00</b>	Current month, day, and year
MENU ↓	<b>DAY TUE</b>	Current day of week
MENU ↓	<b>DAY OCCURS # 1</b>	The number that appears (1-5) relates to the number of times that a given day occurs in the current month. For instance, if the current day is TUESday, this screen example displays that the current day is the first Tuesday of the month. The control uses these numbers in the calendar exercise mode.
MENU ↓	<b>14-DAY TMR WK 1</b>	If 14-day exerciser mode has been selected, this additional screen will show week 1 or 2 of the current 2-week (14-day) period.
RESET MENU	<b>ENTER INDEX. 1-13</b>	Allows a new index number to be entered.

## Program Switch Off Mode

# Index 5—Time Delays

This index is used to view the controller's time delays. The time delays are shown in minutes and seconds and include the following:

- TDES, Time Delay Engine-Start
- TDNE, Time Delay Normal-to-Emergency
- TDOE, Time Delay Off-to-Emergency
- TDEN, Time Delay Emergency-to-Normal
- TDON, Time Delay Off-to-Normal
- TDEC, Time Delay Engine Cooldown

Key Entry	Display	Description
	<b>Enter Index 1-13</b>	Controller is waiting for user to input an index number.
	<b>INDEX NUMBER 5</b>	Index 5—Time Delays
	<b>TIME DELAY MN:SE</b>	Time delays are shown in minutes:seconds.
	<b>TDES 00:00</b>	Engine-Start Time Delay setting, in minutes:seconds.
	<b>TDNE 00:00</b>	Normal-to-emergency transfer time delay setting in minutes:seconds.
	<b>TDOE 00:00</b>	Off-to-emergency transfer time delay.
	<b>TDEN 00:00</b>	Emergency-to-normal transfer time delay setting in minutes:seconds.
	<b>TDON 00:00</b>	Off-to-normal transfer time delay.
	<b>TDEC 00:00</b>	Engine cooldown time setting in minutes:seconds.
	<b>ENTER INDEX. 1-13</b>	Allows a new index number to be entered.

## Index 6—Normal-Source Voltage, Frequency Settings, and Set Points

This index is used to view the controller’s set points for normal voltage and frequency input, dropout, and pickup set points.

**Key Entry**

**Display**

**Description**

Key Entry	Display	Description
	Enter Index 1-13	Controller is waiting for user to input an index number.
6 THU	INDEX NUMBER    6	Index 6—Normal-Source Voltage, Hz Settings, and Set Points
MENU ↓	NORMAL SYSTEM	Settings give reference points for starting transfer sequences. Dropout (DRO) points are those at which the source is unacceptable. Pickup (PKU) points are those at which the source is acceptable.
MENU ↓	NORM VOLTS    000	Normal source <i>rated</i> system voltage for control set point reference. Must be same as system voltage.
MENU ↓	NORM HERTZ    00.0	Normal source, <i>rated</i> system frequency (HERTZ) for control set point reference. Must be same as system frequency.
MENU ↓	N-ONE PH.    SENSE?	Displays one (single)-phase or 3-phase sensing enabled.
MENU ↓	N-OV DRO %    000 ↗	Normal dropout overvoltage setting percent of <i>rated</i> voltage (if option 34J is enabled). <b>NOTE:</b> Option 34J is a factory-installed no-charge option.
MENU →	N-OV DRO V    000↗	Normal overvoltage dropout voltage setting (if option 34J is enabled).
MENU ↓	N-OV PKU %    000 ↗	Normal overvoltage pickup setting percent of <i>rated</i> voltage (if option 34J is enabled).

Key Entry	Display	Description
MENU →	N-OV PKU V      000↲	Normal overvoltage pickup setting (if option 34J is enabled).
MENU ↓	N-UV PKU %      00↲	Normal undervoltage pickup setting percent of <i>rated</i> voltage.
MENU →	N-UV PKU V      000↲	Normal undervoltage pickup voltage setting.
MENU ↓	N-UV DRO %      00↲	Normal undervoltage dropout setting percent of <i>rated</i> voltage.
MENU →	N-UV DRO V      000↲	Normal undervoltage dropout voltage setting.
MENU ↓	N-OF DRO %      00↲	Normal overfrequency dropout setting percent of <i>rated</i> frequency (if option 34J is enabled).
MENU →	N-OF DRO HZ      00.0↲	Normal overfrequency dropout Hz setting (if option 34J is enabled).
MENU ↓	N-OF PKU %      00↲	Normal overfrequency pickup setting percent of <i>rated</i> frequency (if option 34J is enabled).
MENU →	N-OF PKU HZ      00.0↲	Normal overfrequency pickup Hz setting (if option 34J is enabled).
MENU ↓	N-UF PKU %      00 ↲	Normal underfrequency pickup setting percent of <i>rated</i> frequency (if option 34J is enabled).
MENU →	N-UF PKU HZ      00.0↲	Normal underfrequency pickup Hz setting (if option 34J is enabled).
MENU ↓	N-UF DRO %      00 ↲	Normal underfrequency dropout setting percent of <i>rated</i> frequency (if option 34J is enabled).
MENU →	N-UF DRO HZ      00.0↲	Normal underfrequency dropout Hz setting (if option 34J is enabled).
RESET MENU	ENTER NO. 1-13	Allows a new index number to be entered.

## Index 6—Normal Voltage and Frequency Settings and Trip Point Display Variances Due to Different Option Selections

If normal-source pickup (PKU) and dropout (DRO) settings with normal and emergency over- and		undervoltage/frequency sensing <i>are not enabled</i> (index 11), Index 6 display steps will be as follows.	
NORMAL SYSTEM			
NORM VOLTS		000	
NORM HERTZ		00.0	
N-3 PH. SENSE?		OR	
		N-ONE PH. SENSE?	
N-UV PKU %		MENU →	
00▶		N-UV PKU V	
		000▶	
N-UV DRO %		MENU →	
00▶		N-UV DRO V	
		000▶	

Selecting three-phase or single-phase affects the displays that user will see in Index 1.

Dropout (DRO) settings must be at least 2% different than pickup (PKU) settings. Dropout settings will have priority over pickup settings. That is, if a dropout setting is entered that is within 2% of a pickup setting, the pickup setting will be automatically adjusted to be 2% different than the dropout setting.

The normal source will be considered available when bus voltage and frequency are within the pickup settings for at least a half second and phases are in proper sequence (if Index 11 phase sequence protection is enabled).

The normal source will be considered unavailable when bus voltage and frequency are outside of the dropout settings for at least a half second.

## Index 7—Emergency-Source Voltage, Frequency Settings, and Set Points

This index is used to view the controller’s set points for emergency voltage and frequency input, dropout, and pickup set points.

**Key Entry**

**Display**

**Description**

Key Entry	Display	Description
	Enter Index 1-13	Controller is waiting for user to input an index number.
7 YES	INDEX NUMBER 7	Index 7—Emergency-Source Voltage, Hz Settings, and Trip Points
MENU ↓	EMERGENCY SYSTEM	Settings give reference points for starting transfer sequences. Dropout (DRO) points are those at which the source is unacceptable. Pickup (PKU) points are those at which the source is acceptable.
MENU ↓	EMER VOLTS      000	Emergency source <i>rated</i> system voltage for control set point reference.
MENU ↓	EMER HERTZ      00.0	Emergency source <i>rated</i> system frequency (Hertz).
MENU ↓	E-ONE PH.SENSE ?	Displays one (single)-phase or 3-phase sensing enabled.
MENU ↓	E-OV DRO %      000 ▶	Emergency source overvoltage dropout setting percent of <i>rated</i> voltage (if option 34J is enabled).
MENU →	E-OV DRO V      000▶	Emergency source overvoltage dropout voltage setting (if option 34J is enabled).
MENU ↓	E-OV PKU %      000▶	Emergency source overvoltage pickup setting percent of <i>rated</i> voltage (if option 34J is enabled).
MENU →	E-OV PKU V      000 ▶	Emergency source overvoltage pickup setting (if option 34J is enabled).
MENU ↓	E-UV PKU %      00 ▶	Emergency source undervoltage pickup setting percent of <i>rated</i> (if option 34J is enabled).

Key Entry	Display	Description
MENU →	E-UV PKU V    000 ↗	Emergency source undervoltage pickup setting (if option 34J is enabled).
MENU ↓	E-UV DRO %    00 ↗	Emergency source undervoltage dropout setting percent of <i>rated</i> voltage (if option 34J is enabled).
MENU →	E-UV DRO V    000↗	Emergency source undervoltage dropout setting (if option 34J is enabled).
MENU ↓	E-OF DRO %    000↗	Emergency source overfrequency dropout setting percent of <i>rated</i> frequency (if option 34J is enabled).
MENU →	EOF DRO HZ    00.0↗	Emergency source overfrequency dropout frequency setting (if option 34J is enabled).
MENU ↓	E-OF PKU %    000 ↗	Emergency source overfrequency pickup setting percent of <i>rated</i> frequency (if option 34J is enabled).
MENU →	EOF PKU HZ    00.0↗	Emergency source overfrequency pickup frequency setting (if option 34J is enabled).
MENU ↓	E-UF PKU %    00↗	Emergency source underfrequency pickup setting percent of <i>rated</i> frequency.
MENU →	EUF PKU HZ    00.0↗	Emergency source underfrequency pickup setting.
MENU ↓	E-UF DRO %    00↗	Emergency source underfrequency dropout percent of <i>rated</i> frequency.
MENU →	EUF DRO HZ    00.0↗	Emergency source underfrequency dropout setting.
RESET MENU	ENTER NO. 1-13	Allows a new index number to be entered.

## Index 7—Emergency Voltage and Frequency Settings and Trip Point Display Variances Due to Different Option Selections

If emergency-source pickup (PKU) and dropout (DRO) settings with normal and emergency over- and undervoltage/frequency sensing *are not*

*enabled* (index 11), Index 7 display steps will be as follows.

EMERGENCY SYSTEM			
EMER VOLTS	000		
EMER HERTZ	00.0		
E-3 PH. SENSE?		OR	E-ONE PH. SENSE?
E-UV PKU %	00↗	MENU →	E-UV PKU V
E-UV DRO %	00↗	MENU →	E-UV DRO V
E-UF PKU %	00 ↗	MENU →	E-UF PKU HZ
E-UF DRO %	00 ↗	MENU →	E-UF DRO HZ

Selecting three-phase or single-phase affects the displays that the user will see in Index 2.

The emergency source will be considered available when bus voltage and frequency are within the pickup settings for at least a half second and phases are in

proper sequence (if phase sequence protection is enabled).

The emergency source will be considered unavailable when bus voltage and frequency are outside of the dropout settings for at least a half second.

## Program Switch Off Mode

# Index 8—Plant Exerciser Settings







This index is used to view the plant exerciser settings. These settings include calendar, 14-day, or 7-day modes depending on which option was chosen.

Key Entry	Display	Description
	<b>Enter Index 1-13</b>	Controller is waiting for user to input an index number.
<b>8</b> NO	<b>INDEX NUMBER 8</b>	Index 8—Plant Exerciser Settings
MENU ↓	<b>PLANT EXERCISER</b>	Display will show if Plant Exerciser (option 23) is enabled.
MENU ↓	<b>CALENDAR MODE</b> →	Indicates exercise schedule type selected. Mode types are calendar, 14-day, or 7-day.
MENU →	<b>14 DAY ?</b> <b>NO</b> →	
MENU →	<b>7 DAY ?</b> <b>NO</b> →	
MENU →	<b>CALENDAR ?</b> <b>YES</b> →	Displays that calendar mode has been selected.

## Calendar Mode

The **calendar mode** allows up to 5 events with 1 or 2 exercise occurrences each. The calendar date for each occurrence is automatically set according to the date setting entered in Index 4. This is a true calendar that knows the occurrences of days in any month. Relationships of calendar days and dates to occurrence

days are illustrated below. Occurrence numbers for days in a typical month are shown in shaded columns. If a day occurrence number of 5 is entered, the exercise run may not occur every month. If at all possible, avoid using days with an occurrence number of 5.

SUN	MON	TUE	WED	THU	FRI	SAT
						
		1	2	3	4	5
		1	1	1	1	1
6	7	8	9	10	11	12
1	1	2	2	2	2	2
13	14	15	16	17	18	19
2	2	3	3	3	3	3
20	21	22	23	24	25	26
3	3	4	4	4	4	4
27	28	29	30	31		
4	4	5	5	5		

Key Entry	Display	Description
MENU ↓	#1 ENABLED ? NO ▶	YES would show that an exercise event is enabled. An event can include up to two exercise periods.
MENU →	STRT TM 00:00 AM ▶	Displays the time that the programmed exercise period will start. Default start time is 9:00 AM.
MENU →	DAY OF WEEK TUE ▶	Displays first day of event when system is to exercise. Default setting is TUESday.
MENU →	1ST OCCUR # (1-5) ▶	Displays occurrence number of day for first exercise run of event.
MENU →	2ND OCCUR # (1-5) ▶	Displays occurrence number of day for second exercise run of event.
MENU →	RUN HR:MN 0:00 ▶	Displays length of run time set for each exercise event.
MENU →	LD TRANS YES ▶	YES displays that load will be transferred to the emergency source during the exercise run. NO would show that load will not transfer during the exercise run.
MENU ↓	#2 ENABLED ? NO ▶	Events 2 through 5 will have the same setting choices displayed, as event 1 described above.

### Calendar Mode Summary

EXERCISE EVENT	START TIME	DAY OF WEEK	OCCURENCE #		RUN TIME HR:MN	LOAD TRANSFER
			1ST	2ND		
1 ENABLED	07:30 AM	SAT	2	4	00:45	NO
2 DISABLED	09:00 AM	TUE	1	1	00:00	NO
3 DISABLED	09:00 AM	TUE	1	1	00:00	NO
4 DISABLED	09:00 AM	TUE	1	1	00:00	NO
5 DISABLED	09:00 AM	TUE	1	1	00:00	NO

In the example above, exercise event 1 is enabled. Exercise runs will start at 7:30 AM. The first exercise run will occur on the second SATurday of the month; the

second exercise run will occur on the fourth SATurday. The generator set(s) will run for 45 minutes. Load will not be transferred during the exercise runs.

## 14-Day Mode

The **14-day mode** allows up to 5 events with 1 or 2 exercise runs each in a 14-day (Sunday to Saturday) period. Each exercise run may be scheduled for a particular day of week 1 or week 2 in the 14-day period. The current week will show in index 4 if the 14-day mode has been selected.

The following table displays the relationship among exercise events, start times, selected days for each exercise run, week of the 14-day period, the time that the generator set (emergency source) is to run and whether transfer switch is to transfer load to the emergency source.

Key Entry	Display	Description
MENU ↓	14-DAY MODE    ↓	Indicates exercise schedule type selected.
MENU →	CALENDAR ?    NO →	
MENU →	14 DAY ?        YES →	Displays that 14-day mode has been selected
MENU →	7 DAY ?         NO →	
MENU ↓	#1 ENABLED ?   NO →	YES would show that an exercise event is set to occur. An event can include up to two exercise periods within part of the time frame of the selected schedule.
MENU →	STRT TM    00:00 AM ↓	Displays time that exercise period will start.
MENU →	1ST DAY        TUE →	Displays day for first exercise run of event.
MENU →	2ND DAY        TUE →	Displays day for second exercise run of event.
MENU →	WEEK 1 OR 2    1 →	Displays week of 14-day period for event. See index 4 for current week of 14-day period.
MENU →	RUN HR:MN     0:00 →	Displays length of run time set for each exercise event.
MENU →	LD TRANS        YES →	YES displays that load will be transferred to the emergency source during the exercise run. NO would show that load will not transfer during the exercise run.
MENU ↓	#2 ENABLED ?   NO →	Events 2 through 5 will have the same setting choices displayed, as event 1 described above.

### 14-Day Mode Summary

EXERCISE EVENT	START TIME	DAY OF WEEK		WEEK 1 OR 2	RUN TIME HR:MN	LOAD TRANSFER
		1ST	2ND			
<b>1 ENABLED</b>	<b>07:30 AM</b>	<b>WED</b>	<b>SAT</b>	<b>2</b>	<b>00:45</b>	<b>NO</b>
<b>2 DISABLED</b>	<b>09:00 AM</b>	<b>TUE</b>	<b>TUE</b>	<b>1</b>	<b>00:00</b>	<b>NO</b>
<b>3 DISABLED</b>	<b>09:00 AM</b>	<b>TUE</b>	<b>TUE</b>	<b>1</b>	<b>00:00</b>	<b>NO</b>
<b>4 DISABLED</b>	<b>09:00 AM</b>	<b>TUE</b>	<b>TUE</b>	<b>1</b>	<b>00:00</b>	<b>NO</b>
<b>5 DISABLED</b>	<b>09:00 AM</b>	<b>TUE</b>	<b>TUE</b>	<b>1</b>	<b>00:00</b>	<b>NO</b>

In the example above, exercise event 1 is enabled. Exercise runs will start at 7:30 AM. The first exercise run will occur on WEDnesday of week 2; the second

exercise run will occur on SATurday of week 2. The generator set(s) will run for 45 minutes. Load will not be transferred during the exercise runs.

## 7-Day Mode

The **7-day mode** allows up to 5 events with 1 or 2 exercise runs each in a 7-day period.

Key Entry	Display	Description
MENU ↓	7-DAY MODE    ▶	Indicates exercise schedule type selected.
MENU →	CALENDAR ?    NO ▶	
MENU →	14 DAY ?    NO ▶	
MENU →	7 DAY ?    YES ▶	Displays that 7-day mode has been selected.
MENU ↓	#1 ENABLED ?    NO ▶	YES would show that an exercise event is enabled. An event can include upto two exercise periods within part of the time frame of the selected schedule (calendar, 14-day, or 7-day).
MENU →	STRT TM 00:00    AM ▶	Displays time that exercise period will start.
MENU →	1ST DAY    TUE ▶	Displays day for first exercise run of event.
MENU →	2ND DAY    TUE ▶	Displays day for second exercise run of event.
MENU →	RUN HR:MN    0:00 ▶	Displays length of run time set for each exercise event.
MENU →	LD TRANS    YES ▶	YES displays that load will be transferred to the emergency source during the exercise run. NO would show that load will not transfer during the exercise run.
MENU ↓	#2 ENABLED ?    NO ▶	Events 2 through 5 will have the same setting choices displayed, as event 1 described above.

The following table displays the relationship among exercise events, start times, selected days for each exercise run, the time that the generator set (emergency

source) is to run and whether the transfer switch is to transfer the load to the emergency source.

<b>7-Day Mode Summary</b>					
EXERCISE EVENT	START TIME	DAY OF WEEK		RUN TIME HR:MN	LOAD TRANSFER
		1ST	2ND		
<b>1 ENABLED</b>	<b>07:30 AM</b>	<b>WED</b>	<b>SAT</b>	<b>00:45</b>	<b>NO</b>
<b>2 DISABLED</b>	<b>09:00 AM</b>	<b>TUE</b>	<b>TUE</b>	<b>00:00</b>	<b>NO</b>
<b>3 DISABLED</b>	<b>09:00 AM</b>	<b>TUE</b>	<b>TUE</b>	<b>00:00</b>	<b>NO</b>
<b>4 DISABLED</b>	<b>09:00 AM</b>	<b>TUE</b>	<b>TUE</b>	<b>00:00</b>	<b>NO</b>
<b>5 DISABLED</b>	<b>09:00 AM</b>	<b>TUE</b>	<b>TUE</b>	<b>00:00</b>	<b>NO</b>

In the example above, exercise event 1 is enabled. Exercise runs will start at 7:30 AM. The first exercise run will occur on WEDnesday. The second exercise run will

occur on SATurday. The generator set(s) will run for 45 minutes. Load will not be transferred during the exercise runs.

## One-Time Exercise

The following (generator set) engine start sequence may be used with any plant exerciser mode or with the plant exerciser option disabled.

Key Entry	Display	Description
<div style="border: 1px solid black; padding: 2px; width: 30px; margin: 0 auto;">MENU ↓</div>	<div style="border: 1px solid black; padding: 5px; width: 150px; margin: 0 auto;">ENG START ?    NO ▶</div>	<p>Display displays that the generator set has not (NO) or has (YES) been signaled to run for a one-time exercise. This submenu feature allows the generator set to be run for a set time (up to 72 hours) in order to keep it (emergency source) available.</p> <p><b>NOTE:</b> All choices for the engine-start submenu will reset to NO/00:00 after the engine-start sequence setup has completed timing.</p>
<div style="border: 1px solid black; padding: 2px; width: 30px; margin: 0 auto;">MENU →</div>	<div style="border: 1px solid black; padding: 5px; width: 150px; margin: 0 auto;">RUN HR:MN    00:00 ▶</div>	<p>Displays the amount of time that the generator set is to run during the engine-start period.</p>
<div style="border: 1px solid black; padding: 2px; width: 30px; margin: 0 auto;">MENU →</div>	<div style="border: 1px solid black; padding: 5px; width: 150px; margin: 0 auto;">LD TRANS ?    NO ▶</div>	<p>YES displays that the transfer switch will transfer load during the engine-start period. NO displays that load will not be transferred to the generator set during the engine-start period.</p>
<div style="border: 1px solid black; padding: 2px; width: 30px; margin: 0 auto;">MENU →</div>	<div style="border: 1px solid black; padding: 5px; width: 150px; margin: 0 auto;">BP TDNE ?    NO ▶</div>	<p>YES displays that the normal-to-emergency time delay is to be bypassed when the generator set is started in the engine-start mode. NO displays that the normal-to-emergency time delay will not be bypassed.</p>
<div style="border: 1px solid black; padding: 2px; width: 30px; margin: 0 auto;">MENU →</div>	<div style="border: 1px solid black; padding: 5px; width: 150px; margin: 0 auto;">BP TDEN ?    NO ▶</div>	<p>YES displays that the emergency-to-normal time delay is to be bypassed when returning to normal from the engine-start mode. NO displays that emergency-to-normal time delay will not be bypassed.</p>
<div style="border: 1px solid black; padding: 2px; width: 30px; margin: 0 auto;">MENU ↓</div>	<div style="border: 1px solid black; padding: 5px; width: 150px; margin: 0 auto;">COUNTDOWN    00:00</div>	<p>Displays the amount of time (hours and minutes) left in the exercise on engine start period.</p>
<div style="border: 1px solid black; padding: 2px; width: 30px; margin: 0 auto;">RESET MENU</div>	<div style="border: 1px solid black; padding: 5px; width: 150px; margin: 0 auto;">ENTER NO. 1-13</div>	<p>Allows a new index number to be entered.</p>

### NOTE

*To stop the exercise timer during an exercise run, press the EXER STOP key. Pressing the EXER STOP key will zero out the remaining exercise time. The generator set will continue to run through its timed cooldown cycle.*

## Program Switch Off Mode

# Index 9—Load-Shed Settings

This index is used to view the load-shed settings. These settings include the time delays before and after, normal-to-emergency switching and emergency-to-normal switching. The sequence timing and number of loads to be shed and returned are also shown.

Key Entry	Display	Description
	Enter Index 1-13	Controller is waiting for user to input an index number.
9 MON	INDEX NUMBER 9	Index 9—Load-Shed Settings
MENU ↓	LOAD SHED MN:SE	Selection title display displays that load-shed times will be shown in minutes and seconds before and after transfer. See Appendix IV for standard and extended setting ranges. The transfer switch <b>must</b> be equipped with a load-shed circuit board for load-shed settings to be effective.
MENU ↓	NORM-EMER →	Scan across for normal-to-emergency load-shed settings.
MENU →	BEFORE :00 →	Displays time that loads are shed, in minutes:seconds, after normal-to-emergency time delay before the start of the transfer. All 9 load blocks will be shed at one time.
MENU →	AFTER :00 →	Displays time, in minutes:seconds, after normal-to-emergency transfer that load(s) are to remain shed.
MENU →	SEQUENCE :00 →	Displays time between individual sequenced load returns, in minutes:seconds, after a normal-to-emergency transfer. If sequence time is 00:00, all 9 load control relays will energize to return load simultaneously. With a sequence time set, relays 1 through 9 will operate in sequence. Up to 9 loads may be controlled by sequence.
MENU →	LOADS RETURN (#) →	Displays the number of loads (up to 9) to be controlled in sequence by load-control relays 1-9.

Key Entry	Display	Description
MENU ↓	EMER-NORM    ▶	Scan across for emergency-to-normal load-shed settings.
MENU →	BEFORE        :00 ▶	Displays time that loads are shed, in minutes:seconds, after emergency-to-normal time delay is complete before the start of the transfer. All load blocks will be shed.
MENU →	AFTER         :00 ▶	Displays time after emergency-to-normal transfer, in minutes:seconds, that loads will remain shed.
MENU →	SEQUENCE     :00 ▶	Displays time between individual sequenced load returns, in minutes:seconds, after an emergency-to-normal transfer. If sequence is 00:00, all 9 load-shed relays will energize to return load simultaneously. With a sequence time set, relays 1 through 9 will operate in sequence. Up to 9 loads may be controlled by sequence.
MENU →	LOADS RETURN (#) ▶	Displays number of loads (up to 9) to be controlled in sequence by relays 1-9.
RESET MENU	ENTER NO. 1-13	Allows a new index number to be entered.

## Index 10—Source History

This index displays the failure type and summary of source failures for the four most recent failures.

Key Entry	Display	Description
	Enter Index 1-13	Controller is waiting for user to input an index number.
1 FRI	0	INDEX NUMBER 10
MENU ↓	SOURCE HISTORY	Selection displays failure type and summary of source failures for four most recent failures.
MENU ↓	RECORD #1 ▶	Scan across for description of most recent failure.
MENU →	EMER UNDER FREQ	Describes source and type of failure. See Appendix II for a list of source history messages.
MENU →	DATE 00-00-00 ▶	Month, date, and year of failure.
MENU →	TIME 00:00 AM(PM)	Time of day of failure.
MENU ↓	RECORD #2 (3,4) ▶	Scan across for descriptions of the second-most recent, third-most recent, and fourth-most recent failure.
MENU ↓	OUTAGE #1 00 :00	Displays time elapsed during most recent source outage or fault (hours:minutes for record #1 only). Resets to zero after 24 hours.
RESET MENU	ENTER NO. 1-13	Allows a new index number to be entered.

## Index 11—Installed Control Options

This index displays which shunt-enabled options/features are installed. These options/features cannot be enabled or disabled from the keyboard; they must be hard-wired.

**Key**

Entry	Display	Description
	Enter Index 1-13	Controller is waiting for user to input an index number.
<div style="display: inline-block; border: 1px solid black; padding: 2px; margin-right: 5px; text-align: center;">1 FRI</div> <div style="display: inline-block; border: 1px solid black; padding: 2px; margin-right: 5px; text-align: center;">1 FRI</div>	INDEX NUMBER 11	Index 11—Installed Control Options
<div style="border: 1px solid black; padding: 2px; text-align: center;">MENU ↓</div>	CONTROL OPTIONS	Submenu for enabled/disabled control options/features. These are shunt-enabled and cannot be enabled or disabled from the keypad.
<div style="border: 1px solid black; padding: 2px; text-align: center;">MENU ↓</div>	INPHASE MON    YES	Displays inphase monitor enabled (YES) or disabled (NO). Available on ZC style power switches only.
<b>NOTE</b>		
When a programmed transition switch is ordered, the inphase monitor option is disabled by the microprocessor.		
<div style="border: 1px solid black; padding: 2px; text-align: center;">MENU ↓</div>	PHA SEQ/LOSS    YES	Displays source phase sequence enabled (YES) or disabled (NO). Transfer switch contactor lug connections must be properly phased in order for this option to function. Phase sequence (option 34-Z) should be enabled only for 3-phase applications.
<div style="border: 1px solid black; padding: 2px; text-align: center;">MENU ↓</div>	NORM & EMER    YES	Displays normal and emergency, overvoltage and undervoltage, and overfrequency and underfrequency sensing enabled (YES) or disabled (NO).
<div style="border: 1px solid black; padding: 2px; text-align: center;">MENU ↓</div>	PLANT EXERC    YES	Displays generator set/system exerciser enabled (YES), or disabled (NO). <b>The generator set may be exercised even if the plant exerciser option is disabled by using an engine-start sequence.</b>



**TD EXTENDED YES**

Displays extended time delay enabled (YES) or disabled (NO). See Appendix IV for standard ranges. Extended time delays may be set up to 99 minutes.



**MAN OVERRIDE YES**

Displays manual override enabled (YES) or disabled (NO). Enabled manual override (YES) allows automatic transfer to an available source when a connected source fails. Transfer time delays will be bypassed. Disabled manual override (NO) will wait for manual operation and will not automatically seek an available source.



**OFF DELAYS YES**

Displays off position time delays are enabled (YES) or disabled (NO).



**ENTER NO. 1-13**

Allows a new index number to be entered.

## **Index 12—Voltage-Sensing Calibration**

Index 12 contains factory settings that will not have to be changed unless the main logic control circuit board has been replaced.

**NOTE**

Contact your local distributor/dealer to calibrate.

## Index 13—Remote Control and Monitoring Settings

Index 13 is used to view the communication setup. Included in the setup is the type of communication, address of transfer switch, password, and baud rate.

Key Entry	Display	Description
	Enter Index 1-13	Controller is waiting for user to input an index number.
1 FRI    3 SUN	INDEX NUMBER 13	Index 13—Remote Control and Monitoring Settings
MENU ↓	REMOTE CONTROL	Submenu for remote control settings. Communications may be enabled for one of the following single or network connection types.
MENU ↓	ON-LINE?    YES/NO	Displays whether or not a PC is connected for remote monitoring and programming.
MENU ↓	LOCAL?    YES/NO	Displays whether a PC is to be connected with a local single connection.
MENU ↓	LAN?    YES/NO ↘	Displays whether a PC is to be connected through a Local Area Network (LAN).
MENU →	ADDRESS    (#) ↘	LAN address number for the transfer switch (1-128).
MENU ↓	REMOTE?    YES/NO ↘	Displays whether a PC is to be connected through a remote single connection.

Key Entry	Display	Description
MENU →	SYS. ID            0000	Password, up to six digits.
MENU ↓	REMLAN?    YES/NO →	Displays whether a PC is to be connected through a Remote Local Area Network (LAN) connection.
MENU →	SYS. ID            0000	Password, up to six digits.
MENU ↓	BAUD RATE        9600	Baud rate for the modem(s) or data connection used to connect the remote computer(s) to the transfer switch. The default setting is 9600. Choices are 2400, 4800, or 9600.
RESET MENU	ENTER NO. 1-13	Allows a new index number to be entered.

**This completes the off mode overview.**

# Notes

# Section 5. Programming Switch Local Mode

## Index List

### Local Mode

With the programming mode key switch in the LOCAL position, transfer switch control and plant exerciser settings can be made using the keypad. This section will guide the user through setting procedures.

This is a list of programming and monitoring menus used when the programming switch is in the LOCAL MODE. The Index number associated with each menu is used to gain accesses to the submenu under that area. Reviewing these menus will familiarize the user with the keypad functions and the LCD display.

- **Index 1, Normal Voltage and Frequency (NORMAL VOLT and FREQ.)** Index 1 displays actual normal source voltage, frequency, and phase sequence.
- **Index 2, Emergency Voltage and Frequency (EMER VOLT and FREQ.)** Index 2 displays actual emergency source voltage, frequency and phase sequence.
- **Index 3, Operational Records (RECORDS ACTUAL, RECORDS MAINTENANCE.)** index 3 contains two sets of records: ACTUAL and MAINTENANCE. ACTUAL records are cumulative since initial controller setup. MAINTENANCE records are those kept by the controller since the last time it was reset.
- **Index 4, Clock, Day, and Calendar (TIME, DATE, DAY.)** Index 4 displays time, date, day, and days occurrence number (1-5) in the present month.
- **Index 5, Time Delays (TIME DELAY MN:SE.)** Index 5 displays time delay settings associated with ON-END LEDs on the front panel.
- **Index 6, Normal Voltage and Frequency Settings and Trip Points (NORMAL SYSTEM.)** Index 6 displays normal-source trip point settings that will initiate a transfer sequence.
- **Index 7, Emergency Voltage and Frequency Settings and Trip Points (EMERGENCY SYSTEM.)** Index 7 displays emergency-source trip point settings that will initiate a transfer sequence.
- **Index 8, Plant Exerciser (PLANT EXERCISER.)** Index 8 displays the exerciser schedule type selections and settings for scheduled days and times.
- **Index 9, Load Shed (LOAD SHED MN:SE.)** Index 9 displays settings for the number of load blocks to be shed and/or returned, and the time between each load-shed and/or return signal.
- **Index 10, Source History (SOURCE HISTORY.)** Index 10 displays fault status and summaries describing the four most recent source failures.
- **Index 11, Installed Options (CONTROL OPTIONS.)** Index 11 displays various control options as either enabled or disabled.
- **Index 12, Voltage Calibration (CALIBRATION.)** Index 12 is used to calibrate controller voltage sensing. Contact your local distributor/dealer to calibrate.
- **Index 13, Remote Control Setup (REMOTE CONTROL.)** Index 13 displays connection type and communication settings for monitoring and controlling the transfer switch using a personal computer.

# Index 1—Normal-Source Voltage and Frequency

This index displays the voltage and frequency of the normal source. It also displays phase sequence for three-phase only, if phase sequence is enabled. Voltages and frequencies can only be monitored, not changed.

**NOTE**

If display reads CODE ERROR, press RESET MENU to proceed.

Key Entry	Display	Description
	Enter Index 1-13	Controller is waiting for user to input an index number.
1 FRI	INDEX NUMBER 1	Index 1—Normal-Source Voltage and Frequency
MENU ↓	NORM VOLT & FREQ	Shows actual normal-source voltage, frequency and phase sequence.
MENU ↓	NORM VOLTAGE 000	Normal-source voltage (single-phase shown).  <b>NOTE:</b> For single-phase switches both voltage and frequency are on phase A-C. For three-phase switches, voltage will be shown for A-B, B-C, and then A-C as down arrow is pressed.
MENU ↓	N-FREQ HZ 00.0	Normal-source frequency meter.
MENU ↓	N-PHA SEQ A-B-C	Three-phase only if phase sequence option is enabled. Proper sequence is A-B-C. B-A-C indicates loss of phase sequence, loss of phase voltage or incorrect phase sequence.
RESET MENU	ENTER NO. 1-13	Allows a new index number to be entered.

## Index 1—Normal Voltage and Frequency Display Variances Due to Different Option Selections

If single-phase sensing is selected under Index 6, Index 1 display steps will be as follows.

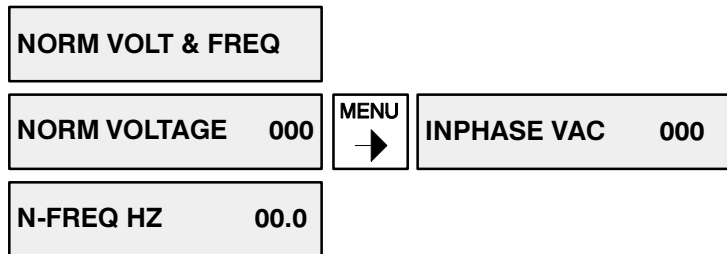

If three-phase sensing is selected under Index 6 and Phase sequence under Index 11 is not enabled, Index 1 display steps will be as follows.

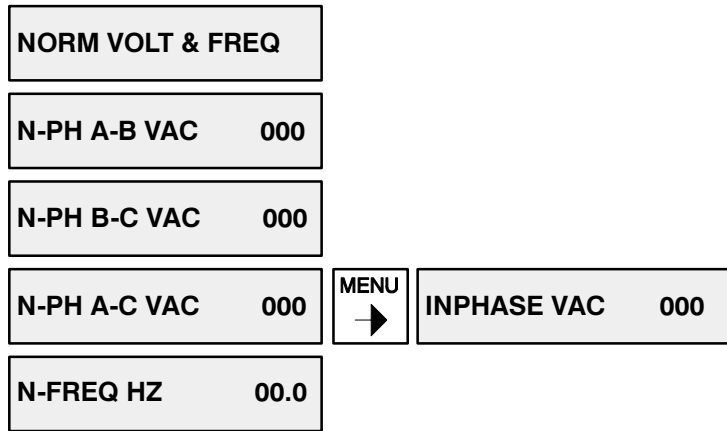

If three-phase sensing is selected under Index 6 and Phase sequence under Index 11 is enabled, Index 1 display steps will be as follows.

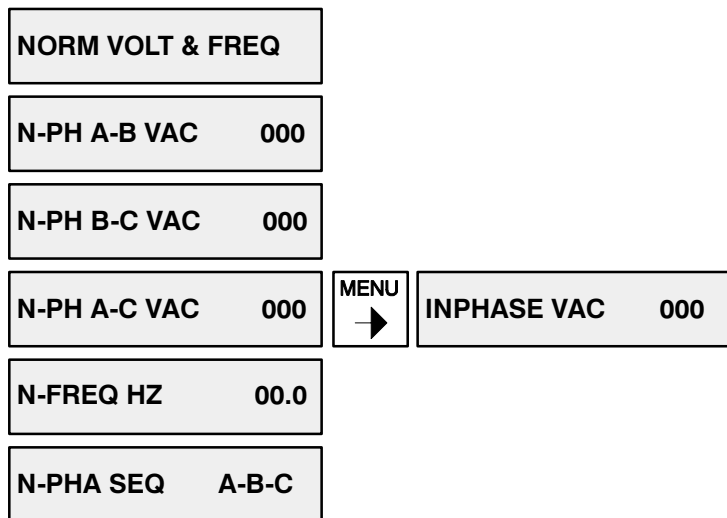

All voltage readings are based on calibrations under Index 12. Voltage and frequency readings are from the system bus. They are compared to entries made in Index 6 to determine normal-source availability.

Phase sequence is independent of other indexes. A phase sequence loss will be indicated by B-A-C and will cause the normal source to be unavailable.

## Index 2—Emergency-Source Voltage and Frequency

This index displays the voltage and frequency of the emergency source. It also displays phase sequence for three-phase only if phase sequence is enabled. Voltages and frequencies can only be monitored, not changed.

**NOTE**

If a generator is used as the emergency source, the display will read 000 for the voltage and frequency unless the generator is running.

Key Entry	Display	Description
	Enter Index 1-13	Controller is waiting for user to input an index number.
	INDEX NUMBER 2	Index 2—Emergency-Source Voltage and Frequency
	EMER VOLT & FREQ	Shows actual normal-source voltage, frequency and phase sequence.
	EMER VOLTAGE 000	Emergency-source voltage.
	E-FREQ HZ 00.0	Emergency-source frequency.
		<b>NOTE:</b> For single-phase switches both voltage and frequency are on phase A-C. For three-phase switches set in Index 7, voltage will be for A-B, B-C, and then A-C.
	E-PHA SEQ A-B-C	Three-phase only, if enabled. Proper sequence is A-B-C. B-A-C indicates loss of phase sequence, loss of phase voltage or incorrect phase sequence.
	ENTER INDEX. 1-13	Allows a new index number to be entered.

## Index 2—Emergency Voltage and Frequency Display Variances Due to Different Option Selections

If single-phase sensing is selected under Index 7, Index 2 display steps will be as follows.

EMER VOLT & FREQ

EMER VOLTAGE 000

E-FREQ HZ 00.0

If three-phase sensing is selected under Index 7 and Phase sequence under Index 11 is not enabled, Index 2 display steps will be as follows.

EMER VOLT & FREQ

E-PH A-B VAC 000

E-PH B-C VAC 000

E-PH A-C VAC 000

E-FREQ HZ 00.0

If three-phase sensing is selected under Index 7 and Phase sequence under Index 11 is enabled, Index 2 display steps will be as follows.

EMER VOLT & FREQ

E-PH A-B VAC 000

E-PH B-C VAC 000

E-PH A-C VAC 000

E-FREQ HZ 00.0











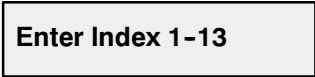

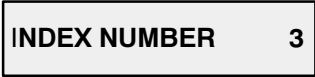

E-PHA SEQ A-B-C













All voltage readings are based on calibrations under Index 12. Voltage and frequency readings are from the system bus. They are compared to entries made in Index 7 to determine emergency source availability.

Phase sequencer is independent of other indexes. A phase sequence loss will be indicated by B-A-C and will cause the emergency source to be unavailable.

## Index 3—Records, Total and Resettable

This index displays information about the controller's history. The index consists of two parts. One is nonresettable and displays total hours in emergency and the total days that the controller has been energized since factory setup. The second part is a user-resettable section where information can be reset and used for maintenance purposes.









Key Entry	Display	Description
		Controller is waiting for user to input an index number.
		Index 3—Records, Total and Resettable
		TOTAL records since factory setup; cannot be reset. Push down arrow until display reads RECORDS-RESET.
		
		To reset records to zero, do the next step. Otherwise, press RESET MENU or menu down.
		Asks if user wants to reset records to zero.
		Shows that resettable records have been reset to zero.
		Shows date of record reset.

Key Entry	Display	Description
		Hours with the transfer switch not in the normal position since last record reset.
		Hours with the emergency source available since last record reset, including exercise periods.
		Days of operation since last record reset.
		Number of transfers since last record reset.
		
		<i>Do this after making any switch settings. The display shows that set points are stored in memory.</i>

## Index 4—Clock and Calendar

Index 4 is used to view the controller’s clock and calendar. The controller uses this information for its exercise feature. SET TIME AND DATE may appear if power to the controller is lost for more than 10 seconds. The system alert lamp may also flash. If this happens use the following procedure to reset the time and date.

Key Entry	Display	Description
		Controller is waiting for user to input an index number.
		Index 4—Clock and Calendar The following clock-calendar settings should be made when the transfer switch is initially installed and energized. SET TIME AND DATE may appear if power to the transfer switch is lost for more than 10 seconds. The system alert lamp may also flash. If this is the case, use the following procedure.
		To set time of day, press digit keys for hours:minutes and press AM or PM to set correct time.
		Shows that clock has been set. Seconds will reset to zero.
		To set date, press digit keys for month, day, and year. Display will show new date setting.
		Shows that date has been set. Day and week of month are automatically set when the date is set.
		Current day of week.

Key Entry	Display	Description
		The number that appears (1-5) relates to the number of times that a given day occurs in the current month. For instance, if the current day is Tuesday, this screen example displays that the current day is the first Tuesday of the month. The control uses these numbers in the calendar exercise mode.
		If 14-day exerciser mode has been selected, this additional screen will show week 1 or 2 of the current 2-week (14-day) period.
		Allows a new index number to be entered.
		<i>Do this after making any switch settings. The display shows that set points are stored in memory.</i>











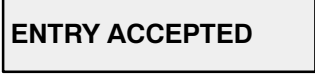

## Program Switch Local Mode

# Index 5—Time Delays

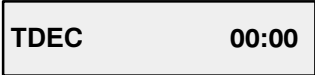
This index is used to view the controller's time delays. The time delays are shown in minutes and seconds and include the following:

- TDES, Time Delay Engine-Start
- TDNE, Time Delay Normal-to-Emergency
- TDOE, Time Delay Off-to-Emergency
- TDEN, Time Delay Emergency-to-Normal
- TDON, Time Delay Off-to-Normal
- TDEC, Time Delay Engine-Cooldown

Key Entry	Display	Description
		Controller is waiting for user to input an index number.
		Index 5—Time Delays See Appendix IV for setting ranges.
		Time delays are entered in minutes:seconds.
		Time Delay Engine-Start. To set time delay press digit keys to get new setting.
		Shows that new setting has been made.
		Normal-to-emergency time delay. To set time delay press digit keys to get new setting.
		Shows that new setting has been made.
		Off-to-emergency time delay. To set time delay, press digit keys to get new setting.
		Shows that new setting has been made.
		Emergency-to-normal time delay. To set time delay, press digit keys to get new setting.











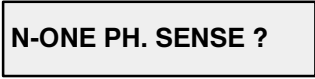



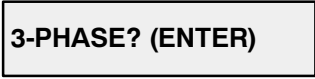

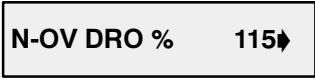

Key Entry	Display	Description
		Shows that new setting has been made.
		Off-to-normal time delay. To set time delay, press digit keys to get new setting.
		Shows that new setting has been made.
		Engine cooldown time delay. To set time delay press digit keys to get new setting.
		Shows that new setting has been made.
		Allows a new index number to be entered.
		<i>Do this after making any switch settings. The display shows that set points are stored in memory.</i>





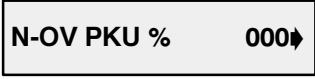

## Program Switch Local Mode

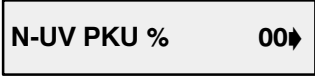







# Index 6—Normal-Source Voltage, Frequency Settings, and Set Points

This index is used to view the controller's set points for normal voltage and frequency input, dropout, and pickup set points. These settings are critical, as they control the transfer switch operation in the normal mode.

Key Entry	Display	Description
	Enter Index 1-13	Controller is waiting for user to input an index number.
6 THU	INDEX NUMBER 6	Index 6—Normal-Source Voltage, Frequency, and Set Points. See Appendix IV for setting ranges. These settings are critical, as they control transfer switch operation.
MENU ↓	NORMAL SYSTEM	Settings give reference points for starting transfer sequences. Dropout (DRO) points are those at which the source is unacceptable. Pickup (PKU) points are those at which the source is acceptable.
MENU ↓	NORM VOLTS 000	To set normal-source/system <i>rated</i> voltage, press digit keys to enter the new setting. <b>This setting MUST match system voltage!</b>
ENTER ↶	ENTRY ACCEPTED	Shows that control accepted the new setting, or
	OR	
	RANGE ERROR	Shows that attempted setting is out of possible range. See Appendix IV for setting ranges.
MENU ↓	NORM HERTZ 60.0	To set normal system <i>rated</i> frequency, press digit keys to enter the new setting. <b>This setting MUST match system frequency!</b>
ENTER ↶	ENTRY ACCEPTED	Shows that new setting has been made, or
	OR	
	RANGE ERROR	Shows that attempted setting is out of possible range.

Key Entry	Display	Description
		If normal-source sensing is to be on one phase (A-C) only, arrow down to the next choice. If normal source sensing is to be 3 phase, press NO.
		
		Press ENTER to make choice.
		<b>NOTE:</b> Enter settings as percentages of rated voltage or frequency.
		Shows dropout setting as percent of normal-source <i>rated</i> voltage. Press digit keys for a new setting (if option 34J is enabled).
		Shows that control accepted the new setting, or
	OR	
		Shows that attempted setting is out of possible range.
		Shows normal overvoltage dropout setting in volts (if option 34J is enabled).
		Shows overvoltage pickup setting as percent of normal-source <i>rated</i> voltage. Press digit keys for a new setting (if option 34J is enabled).
		Shows that new setting has been made, or
	OR	
		Shows that attempted setting is out of possible range.
		Shows undervoltage pickup setting as percent for normal-source <i>rated</i> voltage. Press digit keys for a new setting.







Key Entry	Display	Description
	ENTRY ACCEPTED	Shows that new setting has been made, or
	OR	
	PICKUP ADJUSTED	
	N-UV DRO % 00▶	Shows undervoltage dropout setting as percent of normal-source <i>rated</i> voltage. Press digit keys for a new setting.
	OR	
	RANGE ERROR	
	ENTRY ACCEPTED	Shows that control accepted new setting, or
	OR	
	PICKUP ADJUSTED	
	N-OF DRO % 000▶	Shows overfrequency dropout setting as percent of normal-source <i>rated</i> frequency. Press digit keys for a new setting (if option 34J is enabled).
	OR	
	RANGE ERROR	
	ENTRY ACCEPTED	Shows that control accepted new setting, or
	OR	
	PICKUP ADJUSTED	
	N-OF PKU % 000▶	Shows overfrequency pickup setting as percent of normal-source <i>rated</i> frequency. Press digit keys for a new setting (if option 34J is enabled).
	OR	
	RANGE ERROR	

Key Entry	Display	Description
	ENTRY ACCEPTED	Shows that control accepted new setting, or
	OR	
	PICKUP ADJUSTED	
	N-UF PKU % 00▶	Shows underfrequency pickup setting as percent of normal-source <i>rated</i> frequency. Press digit keys for a new setting.
	OR	
	RANGE ERROR	
	ENTRY ACCEPTED	Shows that control accepted new setting, or
	OR	
	PICKUP ADJUSTED	
	N-UF DRO % 00▶	Shows underfrequency dropout setting as percent of normal-source <i>rated</i> frequency. Press digit keys for a new setting.
	OR	
	RANGE ERROR	
	ENTRY ACCEPTED	Shows that control accepted new setting, or
	OR	
	PICKUP ADJUSTED	
	RANGE ERROR	Shows that attempted setting is out of possible range.
	OR	
	PICKUP ADJUSTED	
	ENTER NO. 1-13	
	STORE SET POINTS	<i>Do this after making any switch settings. The display shows that set points are stored in memory.</i>







## Program Switch Local Mode







# Index 7—Emergency-Source Voltage, Frequency Settings, and Set Points

Index 7 is used to view the controller’s set points for emergency voltage and frequency input, dropout, and pickup set points. These settings are critical, as they control the transfer switch operation in the emergency mode.

Key Entry	Display	Description
	Enter Index 1-13	Controller is waiting for user to input an index number.
	INDEX NUMBER 7	Index 7—Emergency-Source Voltage, Frequency, and Set Points
	EMERGENCY SYSTEM	Settings give reference points for starting transfer sequences. Dropout (DRO) points are those at which the source is unacceptable. Pickup (PKU) points are those at which the source is acceptable.
	EMER VOLTS      000	To set for emergency-source system <i>rated</i> voltage, press digit keys for a new setting. <b>This setting must match emergency source voltage.</b>
	ENTRY ACCEPTED	Shows that control accepted new setting, or
	OR	
	RANGE ERROR	Shows that attempted setting is out of possible range.
	EMER HERTZ      00	Shows emergency-source <i>rated</i> frequency. Press digit keys for a new setting.
	ENTRY ACCEPTED	Shows that control accepted new setting, or
	OR	
	RANGE ERROR	Shows that attempted setting is out of possible range.

Key Entry	Display	Description
MENU ↓	E-ONE PH. SENSE ?	If emergency-source sensing is to be on one phase (A-C) only, arrow down to the next choice. If emergency-source sensing is to be 3 phase, press NO.
8 NO	E-3 PHASE SENSE?	
7 YES	3-PHASE? (ENTER)	Press ENTER to make choice.
ENTER ↵	ENTRY ACCEPTED	Shows that control accepted new setting.
MENU ↓	E-OV DRO %      115	Shows overvoltage dropout setting as percent of emergency-source <i>rated</i> voltage. Press digit keys for a new setting (if option 34J is enabled).
ENTER ↵	ENTRY ACCEPTED	Shows that control accepted new setting, or
	OR	
	RANGE ERROR	Shows that attempted setting is out of possible range.
MENU →	E-OV DRO V      000	Shows emergency overvoltage dropout setting in volts (if option 34J is enabled). <b>NOTE:</b> Enter settings as percentages of rated voltage of frequency.
MENU ↓	E-OV PKU %      000	Shows pickup setting as % of emergency-source <i>rated</i> voltage. Press digit keys for a new setting (if option 34J is enabled).
ENTER ↵	ENTRY ACCEPTED	Shows that control accepted new setting, or
	OR	
	RANGE ERROR	Shows that attempted setting is out of possible range.
MENU ↓	E-UV PKU %      00	Shows pickup setting as percent of emergency-source <i>rated</i> voltage. Press digit keys for a new setting.

Key Entry	Display	Description
	ENTRY ACCEPTED	Shows that control accepted new setting, or
	OR	
	PICKUP ADJUSTED	
	E-UV DRO % 00	Shows dropout setting as percent of emergency-source <i>rated</i> voltage. Press digit keys for a new setting.
	OR	
	RANGE ERROR	
	ENTRY ACCEPTED	Shows that control accepted new setting, or
	OR	
	PICKUP ADJUSTED	
	E-OF DRO % 000	Shows dropout setting as percent of emergency-source <i>rated</i> frequency. Press digit keys for a new setting (if option 34J is enabled).
	OR	
	RANGE ERROR	
	ENTRY ACCEPTED	Shows that control accepted new setting, or
	OR	
	PICKUP ADJUSTED	
	E-OF PKU % 000	Shows overfrequency pickup setting as percent of emergency-source <i>rated</i> frequency. Press digit keys for a new setting (if option 34J is enabled).
	OR	
	RANGE ERROR	

Key Entry	Display	Description
	ENTRY ACCEPTED	Shows that control accepted new setting, or
	OR	
	PICKUP ADJUSTED	
	E-UF PKU % 00	Shows underfrequency pickup setting as percent of emergency-source <i>rated</i> frequency. Press digit keys for a new setting.
	OR	
	RANGE ERROR	
	ENTRY ACCEPTED	Shows that control accepted new setting, or
	OR	
	PICKUP ADJUSTED	
	E-UF DRO% 00	Shows underfrequency dropout setting as percent of emergency-source <i>rated</i> frequency. Press digit keys for a new setting.
	OR	
	RANGE ERROR	
	ENTRY ACCEPTED	Shows that control accepted new setting, or
	OR	
	PICKUP ADJUSTED	
	ENTER NO. 1-13	Allows a new index number to be entered.
	OR	
	RANGE ERROR	
	STORE SET POINTS	<i>Do this after making any switch settings. The display shows that set points are stored in memory.</i>

## Index 8—Plant Exerciser Settings

Index 8 is used to program the plant exerciser settings. Settings include calendar, 7-day, or 14-day mode depending on which option was chosen. This section also includes a manual start for the generator set and a programmable timer for setting run time. Use the







exerciser to ensure that the emergency source is running and available for an anticipated outage or to manually start the engine for an interruptible rate situation.

Key Entry	Display	Description
	Enter Index 1-13	Controller is waiting for user to input an index number.
8 NO	INDEX NUMBER 8	Index 8—Plant Exerciser Settings
MENU ↓	PLANT EXERCISER	Plant exerciser must be enabled in order for settings to be made. Check Index 11, Control Options. Note that system will be set to exercise when events are enabled.
MENU ↓	CALENDAR MODE →	YES or NO displays choice of exercise schedule type. Press the YES key to change the schedule type (other choices will change to NO).
MENU →	14 DAY ? NO →	
MENU →	7 DAY ? NO →	
MENU →	CALENDAR YES →	Shows that calendar mode has been selected.

## Calendar Mode

The **calendar mode** allows up to 5 events with 1 or 2 exercise occurrences each event. The calendar date for each occurrence is automatically set according to the date setting entered in Index 4. This is a true calendar, that knows the occurrences of days in any month. Relationships of calendar days and dates to occurrence

days are illustrated below. Occurrence numbers for days in a typical month are shown in shaded columns. If a day occurrence number of 5 is entered, the exercise run may not occur every month. If at all possible, avoid using days with an occurrence number of 5.













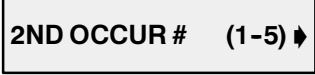

SUN	MON	TUE	WED	THU	FRI	SAT
						
		1 <b>1</b>	2 <b>1</b>	3 <b>1</b>	4 <b>1</b>	5 <b>1</b>
6 <b>1</b>	7 <b>1</b>	8 <b>2</b>	9 <b>2</b>	10 <b>2</b>	11 <b>2</b>	12 <b>2</b>
13 <b>2</b>	14 <b>2</b>	15 <b>3</b>	16 <b>3</b>	17 <b>3</b>	18 <b>3</b>	19 <b>3</b>
20 <b>3</b>	21 <b>3</b>	22 <b>4</b>	23 <b>4</b>	24 <b>4</b>	25 <b>4</b>	26 <b>4</b>
27 <b>4</b>	28 <b>4</b>	29 <b>5</b>	30 <b>5</b>	31 <b>5</b>		

Key Entry	Display	Description
	ENTRY ACCEPTED	Shows that control accepted entry. <b>NOTE:</b> Changing exercise mode will reset all to defaults; previous settings will be lost! If selecting calendar YES, you may schedule up to 5 events on up to 7 different days, 2 exercises for each of 5 weeks.
	#1 ENABLED ? NO ▶	Shows event 1 disabled.
	ENTRY ACCEPTED	
	#1 ENABLED ? YES ▶	Shows event 1 enabled.
	STRT TM 0:00 AM	Shows time of day for exercise start. Press digit and AM/PM keys for a new setting. Default start time is 9:00 AM.
	ENTRY ACCEPTED	Shows that control accepted entry.
	DAY OF WEEK TUE ▶	Shows day of week for event. Press day key for a new setting. Default is TUE.
	ENTRY ACCEPTED	Shows that control accepted entry.

Calendar Mode Setup						
EXERCISE EVENT	START TIME	DAY OF WEEK	Exercise Run		RUN TIME HR:MN	LOAD TRANSFER
			1	2		
1 ENABLED	07:30 AM	SAT	2	4	00:45	NO
<b>E</b>	<b>07:30 AM</b>	<b>SAT</b>	<b>2</b>	<b>4</b>	<b>00:45</b>	
2 DISABLED	09:00 AM	TUE	1	1	00:00	NO
<b>D</b>	<b>09:00 AM</b>	<b>TUE</b>	<b>1</b>	<b>1</b>	<b>00:00</b>	
3 DISABLED	09:00 AM	TUE	1	1	00:00	NO
<b>D</b>	<b>09:00 AM</b>	<b>TUE</b>	<b>1</b>	<b>1</b>	<b>00:00</b>	
4 DISABLED	09:00 AM	TUE	1	1	00:00	NO
<b>D</b>	<b>09:00 AM</b>	<b>TUE</b>	<b>1</b>	<b>1</b>	<b>00:00</b>	
5 DISABLED	09:00 AM	TUE	1	1	00:00	NO
<b>D</b>	<b>09:00 AM</b>	<b>TUE</b>	<b>1</b>	<b>1</b>	<b>00:00</b>	

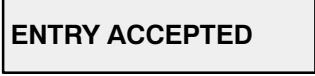
In the example above, exercise event 1 is enabled. Exercise runs will start at 7:30 AM. The first exercise run will occur on the second SATurday of the month; the

second exercise run will occur on the fourth SATurday. The generator set(s) will run for 45 minutes. Load will not be transferred during the exercise runs.

Key Entry	Display	Description
		Shows occurrence number of day for exercise 1 of event. Press digit key for a new setting. If a day occurrence number of 5 is entered, the exercise run may not occur every month. If at all possible, avoid using days with an occurrence number of 5.
		Shows that control accepted entry.
		Shows occurrence number of day for exercise 2 of event. Press digit key for a new setting. If a day occurrence number of 5 is entered, the exercise run may not occur every month. If at all possible, avoid using days with an occurrence number of 5.
		Shows that control accepted entry.
		Shows length of time for exercise period in hours and minutes. Press digit keys for a new setting.
		Shows that control accepted entry.
		YES displays that load will be transferred to the emergency source during the exercise run. NO indicates that load will not transfer during the exercise run. The keypad cannot change setting.
		Follow the steps described in event 1 above to set the desired number of exercise runs for events 2-5.

#### NOTE

*To stop the exercise timer during an exercise run, press EXER STOP key. Pressing the EXER STOP key will zero out the remaining exercise time. The generator set will continue to run through its timed cooldown cycle.*

## 14-Day Mode

If selecting 14-day mode, user may schedule up to 5 events with 1 or 2 exercise runs each in a 14-day (Sunday to Saturday) period. Each exercise run may be

scheduled for a particular day of week 1 or week 2 in the 14-day period. The current week shows in index 4 if the 14-day mode has been selected.

Key Entry	Display	Description
		Shows that 14-day exercise schedule has been selected.
		Shows that control accepted entry.
		Shows event #1 not enabled.
		Shows that control accepted entry.
		Shows event #1 enabled.
		Shows time of day for exercise start. Press digit and AM/PM keys for a new setting. Default is 9:00 AM.
		Shows that control accepted entry.

**NOTE**

Changing exercise mode will reset all settings to their defaults; previous settings will be lost!











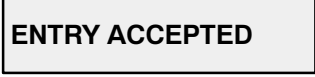
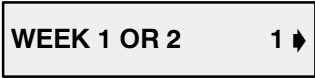

The following table displays the relationships among exercise events, start times, selected days for each

exercise run, week of the 14-day period, the time that the generator set (emergency source) is to run, and whether transfer switch is to transfer load to the emergency source.

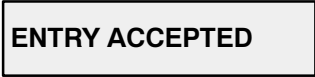
<b>14-Day Mode Setup</b>						
EXERCISE EVENT	START TIME	DAY 1	OF WEEK 2	WEEK 1 OR 2	RUN TIME HR:MN	LOAD TRANSFER
1 ENABLED	07:30 AM	WED	SAT	2	00:45	NO
<b>E</b>	<b>07:30 AM</b>	<b>WED</b>	<b>SAT</b>	<b>2</b>	<b>00:45</b>	
2 DISABLED	09:00 AM	TUE	TUE	1	00:00	NO
<b>D</b>	<b>09:00 AM</b>	<b>TUE</b>	<b>TUE</b>	<b>1</b>	<b>00:00</b>	
3 DISABLED	09:00 AM	TUE	TUE	1	00:00	NO
<b>D</b>	<b>09:00 AM</b>	<b>TUE</b>	<b>TUE</b>	<b>1</b>	<b>00:00</b>	
4 DISABLED	09:00 AM	TUE	TUE	1	00:00	NO
<b>D</b>	<b>09:00 AM</b>	<b>TUE</b>	<b>TUE</b>	<b>1</b>	<b>00:00</b>	
5 DISABLED	09:00 AM	TUE	TUE	1	00:00	NO
<b>D</b>	<b>09:00 AM</b>	<b>TUE</b>	<b>TUE</b>	<b>1</b>	<b>00:00</b>	

In the example above, exercise event 1 is enabled. Exercise runs will start at 7:30 AM. The first exercise run will occur on WEDnesday of week 2; the second

exercise run will occur on SATurday of week 2. The generator set(s) will run for 45 minutes. Load will not be transferred during the exercise runs.

Key Entry	Display	Description
		Shows day of week for exercise 1 of event. Press a day key for a new setting. Default is TUE.
		Shows day of week for exercise 2 of event. Press a day key for a new setting. Default is TUE.
		Shows that control accepted entry.
		Shows week of the two-week period for event 1 to be scheduled. Press digit key 1 or 2 for a new setting.
		Shows that control accepted entry.
		Shows length of time for exercise period in hours and minutes. Press digit keys for a new setting.
		Shows that control accepted entry.
		YES indicates that load will be transferred to the emergency source during the exercise run. NO indicates that load will not transfer during the exercise run.
		Steps may be followed to set the desired number of exercise runs for events 2 through 5, like event 1 described above.

**NOTE**

*To stop the exercise timer during an exercise run, press EXER STOP key. Pressing the EXER STOP key will zero out the remaining exercise time. The generator set will continue to run through its timed cooldown cycle.*

## 7-Day Mode

If selecting 7-day mode, user may schedule up to 5 events on up to 7 days with up to 2 exercise runs per event in a Sunday-Saturday period.

### Key

Entry	Display	Description
		Shows that 7-day exercise schedule has been selected.
		Shows that control accepted entry.
		Shows event 1 not enabled.
		Shows that control accepted entry.
		Shows time of day for exercise start. Press digit keys and AM or PM key for a new setting. Default is 9:00 AM.
		Shows that control accepted entry.
		Shows day of week for exercise 1 of event. Press a day key for a new day. Default is TUE.
		Shows that control accepted entry.
		Shows day of week for exercise 2 of event. Press a day key for a new day. Default is TUE.
		Shows that control accepted entry.



**RUN HR:MN 0:00** ▶

Shows length of time for exercise period in hours and minutes. Press digit keys for a new setting.



**ENTRY ACCEPTED**

Shows that control accepted entry.



**LD TRANS YES** ▶

YES displays that load will be transferred to the emergency source during the exercise run. NO displays that load will not transfer during the exercise run.



**#2 ENABLED NO** ▶

Follow steps to set the desired number of exercise runs for events 2 through 5, like event 1 described above.

**NOTE**

To stop the generator set during an exercise run, press EXER STOP key. Pressing the EXER STOP key will zero out the remaining exercise time. The generator set will continue to run through its timed cooldown cycle.

Changing exercise mode will reset all settings to their defaults; previous settings will be lost!

The following table displays the relationship among exercise events, start times, selected days for each exercise run, the time that the generator set (emergency source) is to run and whether or not transfer switch is to transfer load to the emergency source.

**NOTE**

The 7-day exercise schedule may also be used as a daily peakshaving schedule.

7-Day Mode Setup						
EXERCISE EVENT	START TIME	DAY 1ST	OF	WEEK 2ND	RUN TIME HR:MN	LOAD TRANSFER
1 ENABLED <b>E</b>	07:30 AM <b>07:30 AM</b>	WED <b>WED</b>		SAT <b>SAT</b>	00:45 <b>00:45</b>	NO
2 DISABLED <b>D</b>	09:00 AM <b>09:00 AM</b>	TUE <b>TUE</b>		TUE <b>TUE</b>	00:00 <b>00:00</b>	NO
3 DISABLED <b>D</b>	09:00 AM <b>09:00 AM</b>	TUE <b>TUE</b>		TUE <b>TUE</b>	00:00 <b>00:00</b>	NO
4 DISABLED <b>D</b>	09:00 AM <b>09:00 AM</b>	TUE <b>TUE</b>		TUE <b>TUE</b>	00:00 <b>00:00</b>	NO
5 DISABLED <b>D</b>	09:00 AM <b>09:00 AM</b>	TUE <b>TUE</b>		TUE <b>TUE</b>	00:00 <b>00:00</b>	NO

In the example above, exercise event 1 is enabled. Exercise runs will start at 7:30 AM. The first exercise run will occur on WEDnesday. The second exercise run will











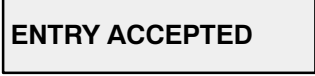

occur on SATurday. The generator set(s) will run for 45 minutes. Load will not be transferred during the exercise runs.

## One-Time Exercise

Submenu allows user to start the generator set and to have run it for a set period of time. Use timer to ensure that the emergency source is running and available for an anticipated outage or to manually start the engine for an interruptible rate situation. User must enter all settings before the generator set can run.

### NOTE

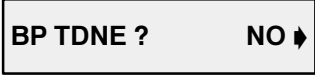
All choices for the engine-start submenu will reset to 00:00 after the engine-start sequence the user has set up has completed timing.









Key Entry	Display	Description
		The following (generator set) engine start sequence may be used with any plant exerciser mode or with the plant exerciser option disabled.
		Shows length of engine run time. Use digit keys to enter a setting (72 hours maximum).
		Shows that control accepted entry.
		If user wants load to transfer to the emergency source during the engine run, press YES and ENTER.
		Shows that control accepted entry.
		If user entered NO as a load-transfer choice, skip this choice. If user entered YES as a load-transfer choice, entering YES here will bypass the normal-to-emergency time delay when load transfers.
		Shows that control accepted entry.

Key Entry	Display	Description
MENU →	BP TDEN ? NO →	If user entered NO as a load-transfer choice, skip this choice. If user entered YES as a load-transfer choice, entering YES here will bypass the emergency-to-normal time delay when load transfers.
ENTER ↵	ENTRY ACCEPTED	Shows that control accepted entry.
MENU →	ENGINE START ? NO →	Entering YES here will start the generator set.
ENTER ↵	ENTRY ACCEPTED	Shows that engine start and/or transfer sequence has started.
MENU ↓	COUNTDOWN :00	Shows the hours and minutes left of the preset engine run or exercise time.
RESET MENU	ENTER NO. 1-13	

## Program Switch Local Mode

# Index 9—Load-Shed Settings

Index 9 is used to program the load-shed settings. Settings include the time delays before and after normal-to-emergency switching and emergency-to-normal switching. Also programmed are the sequence timing and number of loads to be shed and returned.

Key Entry	Display	Description
	Enter Index 1-13	Controller is waiting for user to input an index number.
	INDEX NUMBER 9	Index 9—Load Shed Settings
	LOAD SHED MN:SE	Install load-shed control and dry contact boards in order for load shed to function. Times are to be entered in minutes and seconds. See Appendix D for setting ranges.
	NORM-EMER ▶	Submenu for normal-to-emergency load-shed setup.
	BEFORE :00 ▶	Press digit keys to enter minutes and seconds after normal-to-emergency time delay that loads are to be shed before start of transfer.
	ENTRY ACCEPTED	Shows that control accepted entry.
	AFTER :00 ▶	Press digit keys to enter minutes and seconds after transfer to emergency that loads are to remain shed. If sequence time is 00:00, all 9 load control relays will energize to return load simultaneously. With a sequence time set, relays 1 through 9 will operate in sequence. Up to 9 loads may be controlled by sequence. Press digit keys to enter minutes and seconds after transfer that load returns are to begin.
	ENTRY ACCEPTED	Shows that control accepted entry.
	SEQUENCE :00 ▶	Press digit keys to enter minutes and seconds between individual sequenced load returns.

Key Entry	Display	Description
ENTER ↵	ENTRY ACCEPTED	Shows that control accepted entry.
MENU ↓	LOADS RETURN 0 ▸	Press a digit key (1-9) to enter the number of load blocks to be sequenced. These may be prioritized to include only those to be energized by the emergency source.
ENTER ↵	ENTRY ACCEPTED	Shows that control accepted entry.
MENU ↓	EMER-NORM ▸	Submenu for emergency-to-normal load shedding. Choices to make are same as for normal-to-emergency load shedding preceding.
RESET MENU	ENTER INDEX 1-13	
ENTER ↵	STORE SET POINTS	<i>Do this after making any switch settings. The display shows that set points are stored in memory.</i>











## Index 10—Source History

Index 10 displays the failure type and summary of source failures for the four most recent failures.

Key Entry	Display	Description
	Enter Index 1-13	Controller is waiting for user to input an index number.
1 FRI	0	INDEX NUMBER 10
MENU ↓	SOURCE HISTORY	Selection displays failure type and summary of source failures for four most recent failures.
MENU ↓	RECORD #1 ↘	Scan across for description of most recent failure.
MENU →	EMER UNDER FREQ	Describes source and type of failure. See Appendix II for a list of source history messages.
MENU →	DATE 00-00-00 ↘	Month, date, and year of failure.
MENU →	TIME 00:00 AM(PM)	Time of day of failure.
MENU ↓	RECORD #2 (3,4) ↘	Scan across for descriptions of the second-most recent, third-most recent, and fourth-most recent failure.
MENU ↓	OUTAGE #1 00 :00	Shows time elapsed during most recent source outage or fault (hours:minutes for Record #1 only). Resets to zero after 24 hours.
RESET MENU	ENTER NO. 1-13	Allows a new index number to be entered.

## Index 11—Installed Control Options

Index 11 displays which shunt-enabled options/features are installed. Options/features cannot be enabled or disabled from the keyboard; they must be hard-wired.

Key Entry	Display	Description
	Enter Index 1-13	Controller is waiting for user to input an index number.
 	INDEX NUMBER 11	Index 11—Installed Control Options
	CONTROL OPTIONS	Submenu for enabled/disabled control options/features. These are shunt-enabled and cannot be enabled or disabled from the keypad.
	INPHASE MON YES	Shows inphase monitor enabled (YES) or disabled (NO). Inphase monitor is available only on contactor type, nonprogrammed transition switches. If the contactor is not of this type, the controller will not allow this option to be enabled.
	PHA SEQ/LOSS YES	Shows a source phase sequence is enabled (YES) or disabled (NO). Properly phase transfer switch contactor lug connections in order for this option to function. Only enable phase sequence (option 34-Z) for 3 phase applications.
	NORM & EMER YES	Shows normal and emergency, overvoltage and undervoltage, and overfrequency and underfrequency sensing enabled (YES) or disabled (NO).
	PLANT EXERC YES	Shows generator set/system exerciser enabled (YES), or disabled (NO). <b>The generator set may be exercised even if the plant exerciser option is disabled by using an engine-start sequence.</b>
	TD EXTENDED YES	Shows extended time delay enabled (YES) or disabled (NO). See Appendix IV for standard ranges. Extended time delays may be set up to 99 minutes.
	MAN OVERRIDE YES	Shows manual override enabled (YES) or disabled (NO). Enabled manual override (YES) allows automatic transfer to an available source when a connected source fails. Transfer time delays will be bypassed. Disabled manual override (NO) will wait for manual operation and will not automatically seek an available source.
	OFF DELAYS YES	Shows whether off position time delays are enabled (YES) or disabled (NO). The controller determines if the off position time delays are available for the switch to which it is connected. If it is available, then the jumper will determine if the off position delays are enabled (jumper in) or disabled (jumper out).
	ENTER NO. 1-13	Allows a new index number to be entered.

## **Index 12—Voltage-Sensing Calibration**

Factory settings will not have to change unless the main logic control circuit board has been replaced.















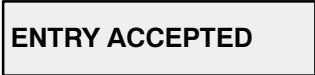

**NOTE**

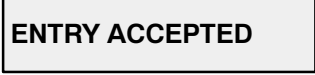
Contact your local distributor/dealer to calibrate.

## Index 13—Remote Control and Monitoring Settings

Index 13 is used to program the communication settings. Included in the setup are the type of communications, address of the transfer switch, password, and baud rate.

Key Entry	Display	Description
	Enter Index 1-13	Controller is waiting for user to input an index number.
1 FRI    3 SUN	INDEX NUMBER 13	Index 13—RemoteControl and Monitoring Settings
MENU ↓	REMOTE CONTROL	Submenu for enabling control and monitoring by a computer and M340+ Monitor software.
MENU ↓	ON-LINE ?      YES	Press NO and ENTER if remote access is to be denied. Otherwise, go to the next step. This does not change other settings.
MENU ↓	LOCAL ?      NO	Press YES and ENTER if computer is cabled directly to COM port (see MainMenu, Program Configuration, in M340+ monitor software manual).
MENU ↓	LAN ?      NO ↗	Press YES and ENTER if computer is connected to control through an ATS Local Area Network.
MENU →	ADDRESS      1	Press digit keys to enter LAN address number for the transfer switch (1-128). This is necessary for the software to call up the desired transfer switch. Use one address number per transfer switch, and use consecutive numbers.
ENTER ↵	ENTRY ACCEPTED	Shows that control accepted entry.
MENU ↓	REMOTE ?      NO ↗	Press YES and ENTER if computer is connected to control through a Remote Single Connection (modem-to-modem).
MENU →	SYS. ID      0000	Press up to 6 digit keys and ENTER to create a password for the respective transfer switch. Press YES and ENTER.

Key Entry	Display	Description
		Press YES and ENTER if computer is connected through a Remote Local Area Network.
		System ID is a 6-digit protection password for a transfer switch network. For maximum protection select a 6-digit nonrepeating password. Example: select 123456, not 2222.
		Shows that control accepted entry.
		Press digit keys to enter LAN address number for the transfer switch (1-128). This is necessary for the software to call up the desired transfer switch. Use one address number per transfer switch, and use consecutive numbers.
		Shows that control accepted entry.
		Press digit keys to enter the baud rate for the modem(s) used to connect the remote computer(s) to the transfer switch. This setting <i>must</i> match the baud rate of modems used and monitor software program configuration. The default setting is 9600. Choices are 2400, 4800, or 9600.
		Shows that control accepted entry.
		
		<i>Do this after making any switch settings. The display shows that set points are stored in memory.</i>

**This completes the local/keypad programming and setup procedure.**

# Notes

# Section 6. Programming Switch Remote Mode

## Remote Communications Connections

### NOTE

See the operation and installation manual for the Remote Monitoring and Control Communication Software or Controller Communication Kits for details. See List of Related Materials in the Introduction section in this manual.

There are four ways to communicate with the transfer switch.

1. **Local Single Connection:** A personal computer is connected directly to the transfer switch's COM port with an RS-232 cable for application when the computer is within 50 feet of the transfer switch, or with an RS-485 cable for application where the computer is up to 4000 feet away from the transfer switch. See Figure 6-2 and Figure 6-3.
2. **Local Area Network:** A personal computer is connected directly to an automatic transfer switch local area network. A Local Area Network (LAN) is a system of connecting more than one automatic
- transfer switch to a single computer. See Figure 6-4.
3. **Remote Single Connection:** A personal computer is connected to a modem. The transfer switch controller is also connected to a modem. The computer communicates with the transfer switch controller via a telephone network. Because a telephone network is used, the computer can be located anywhere a telephone line can be accessed. See Figure 6-5.
4. **Remote Area Network:** A personal computer is connected to a modem. The transfer switch controllers are connected to a LAN network. The computer communicates to the transfer switch controllers via a telephone network that is interfaced to the LAN network. Because a telephone network is used, the computer can be located anywhere a telephone line can be accessed. See Figure 6-6.

## Remote Communication Hardware

The M340+ transfer switch must have option DD-51-A or DD-51-B for the remote communication option to function. Options DD-51-A and DD-51-B include a remote communications board which is located below the main logic board on the enclosure door. This

communication board has a ribbon cable that connects it to the main logic board and a port for plugging in the communications cable (RS-485 for option DD-51-A and RS-232 for option DD-51-B). See Figure 6-1.

## Communication Interface Cables

RS-232 interface cable is capable of communicating between the controller and a personal computer up to 50 feet away. For distances of 50-4000 feet between the controller and PC, add an RS-232-to-RS-485 port

converter. For any distances greater than 4000 feet, connect the controller and computer to a modem and communicate via the telephone network.

# Remote Communication Submenu

Enter the remote control submenu, Index 13. Press the MENU Arrow down key to scroll through a the options. The list below explains each of the options and the proper response depending on the hardware used.

**ON-LINE.** Press YES and ENTER to allow remote access.

**LOCAL.** Press YES and ENTER if a personal computer is connected directly to the microprocessor-controlled

transfer switch's COM port (see Main Menu, Program Configuration in the Monitor Software manual).

**REMOTE.** Press YES and ENTER if a personal computer is connected through a remote single connection (modem-to-modem).

**LAN.** Press YES and ENTER if there is more than one microprocessor-controlled transfer switch connected directly to one computer.

**REMLAN.** Press YES and ENTER if a personal computer accesses an automatic transfer switch local area network through a modem.

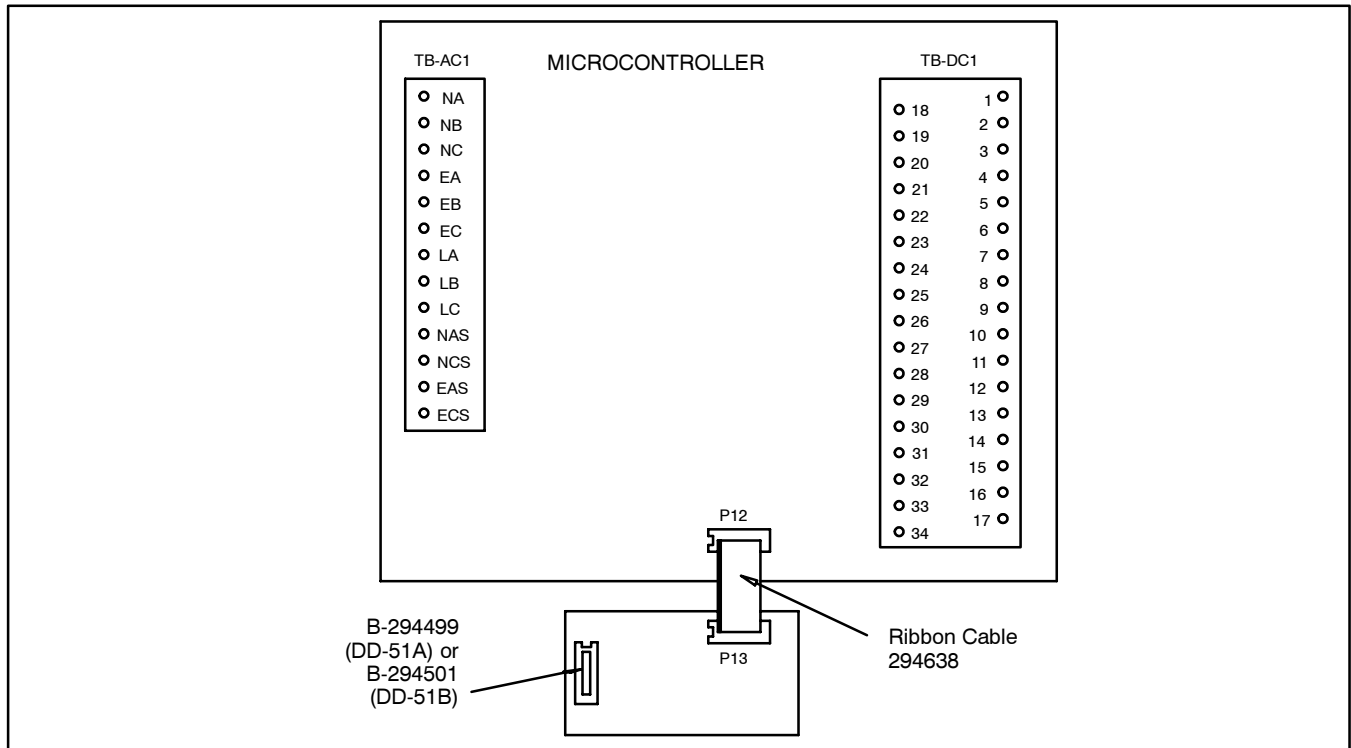

**Figure 6-1. Port Location for Communications**

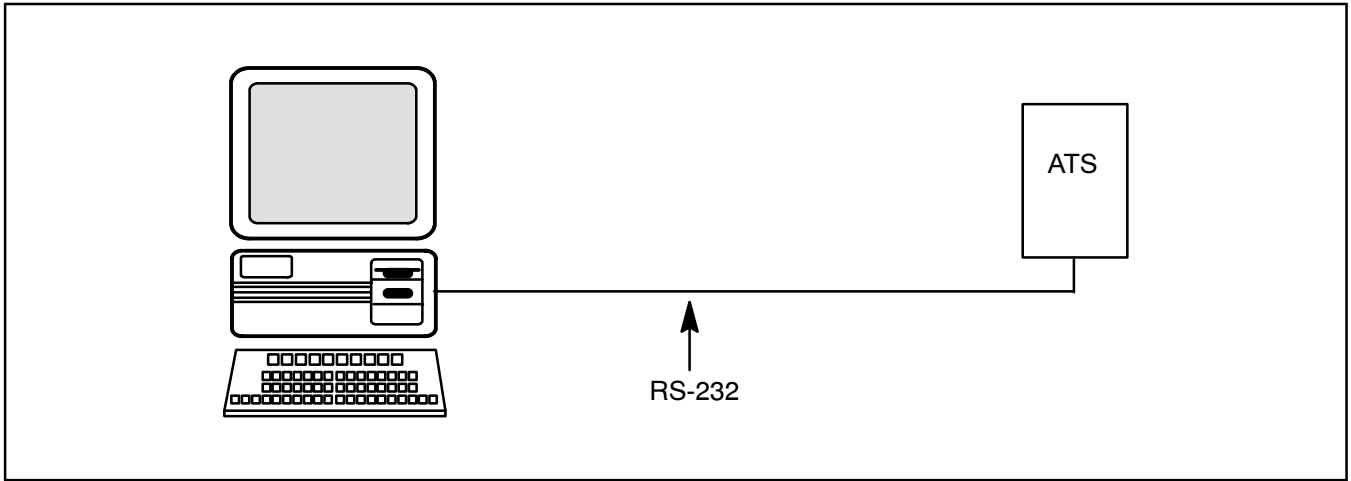

**Figure 6-2. Local Single Connection, up to 50 feet (15.24 meters)**

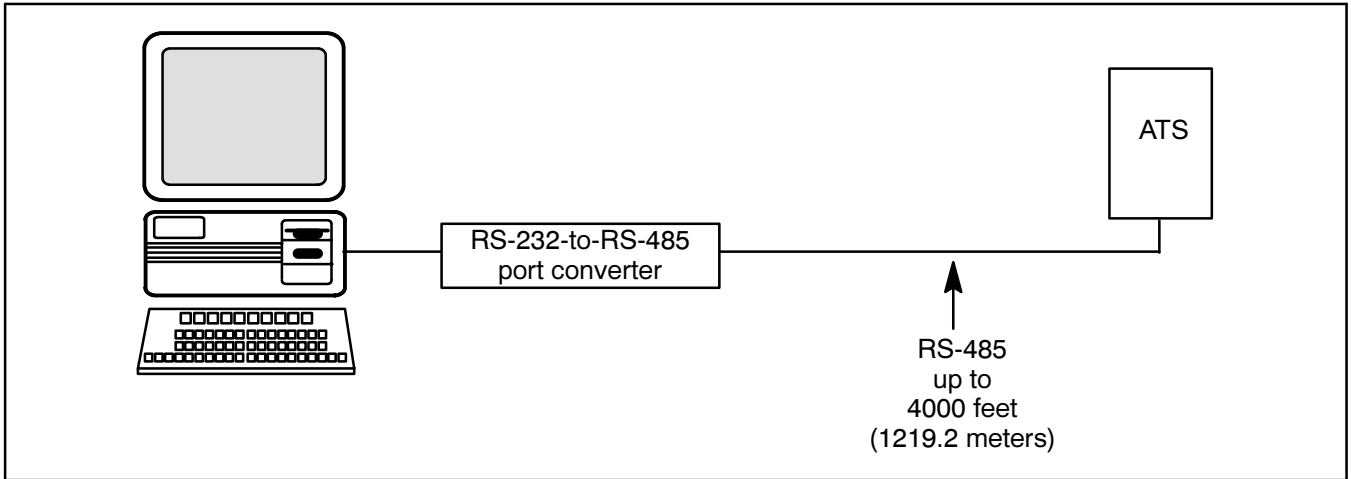

**Figure 6-3. Local Single Connection, up to 4000 feet (15.24 to 1219.2 meters)**

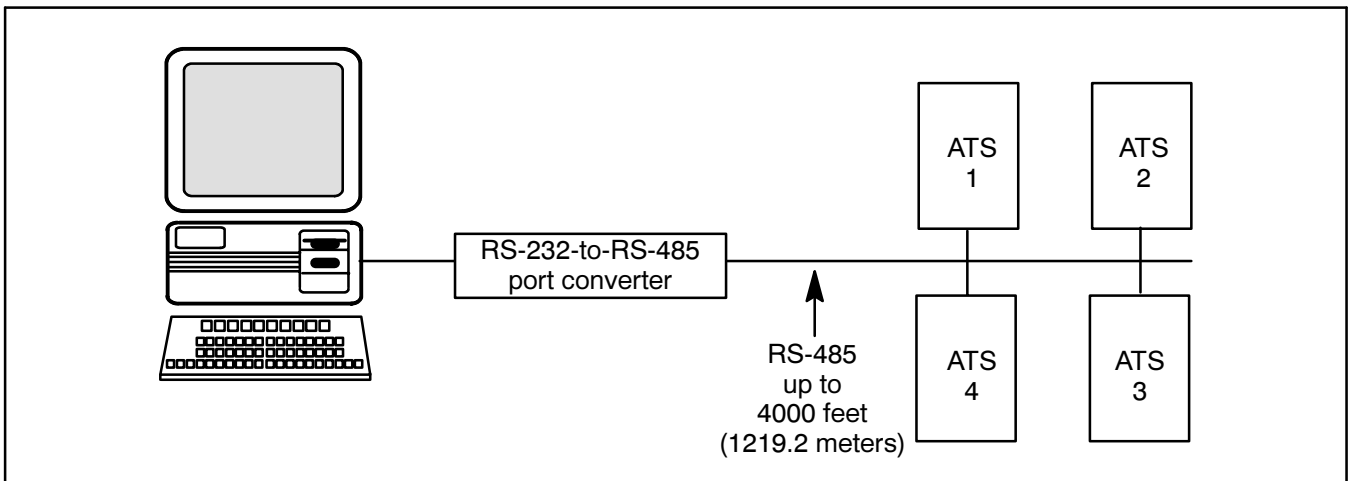

**Figure 6-4. Local Area Network**

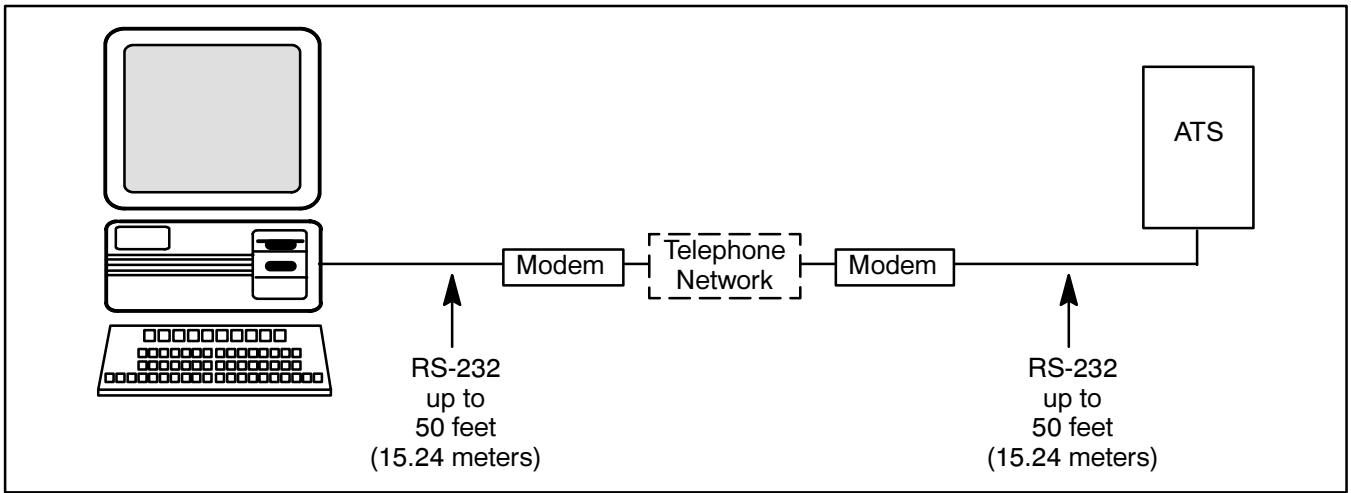

**Figure 6-5. Remote Single Connection**

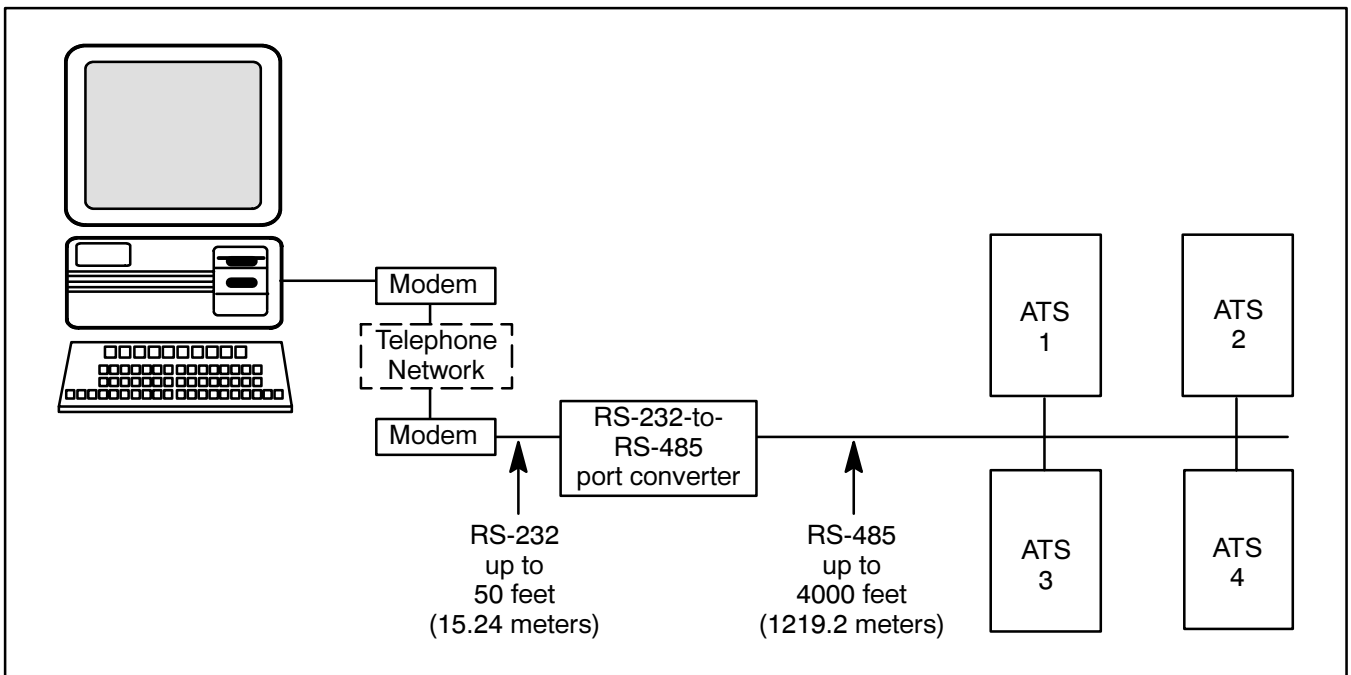

**Figure 6-6. Remote Area Network**

# Section 7. Accessories

## Optional Accessories

### Emergency Source Sensing DD-05-K

Accessory DD-05-K is a circuit board assembly mounted inside the transfer switch with a wiring harness connecting it to the main logic board. This option monitors emergency-source voltage (three phase), and overfrequency (one phase).

Accessory DD-06-F is a two-position switch which allows the emergency source to be tested.

**Auto.** Auto enables automatic transfer switch operation.

**Test.** Test simulates normal source failure.

### Operation Mode Selector Switch DD-06-N,P

Accessories DD-06-N and P are three-position switches which allow the emergency source to be tested.

**DD-06-N.** A three-position switch, momentary test.

**DD-06-P.** A three-position switch, key-operated momentary test.

The three positions are as follows:

**Auto.** Auto position enables automatic transfer switch operation.

**Test.** Test position simulates normal source failure (momentary).

**Engine Start.** Engine start position closes the engine start circuit to test run the generator set. The transfer switch will not transfer unless the normal source fails.

### Operation Mode Selector Switch DD-07-D

Accessory DD-07-D is a four-position switch with a lamp which allows four modes of switch operation. The four positions are as follows:

**Auto.** Auto enables automatic transfer switch operation.

**Test.** Test simulates normal source failure.

**Engine Start.** Engine start position closes the engine-start circuit to test run the generator set. The transfer switch will not transfer unless the normal source fails.

**Off.** Off position de-energizes control circuit and opens the engine start circuit. The transfer switch will not operate.

### Time Delay Override Switch DD-08-C,D

Accessories DD-08-C and D are time delay override switches for bypassing the timers TDEN and TDNE.

**Accessory DD-08-C.** Pressing the switch will bypass the TDEN (Time Delay Emergency to Normal) timer and instantly transfer the load from the emergency source to the normal source, if available.

**Accessory DD-08-D.** Pressing the switch will bypass the TDNE (Time Delay Normal to Emergency) timer and instantly transfer the load from the normal source to the emergency source, if available.

## **Auxiliary Relay Contacts DD-14-G,H,J,K,L,M,N,P,R**

Auxiliary Relay Contacts DD-14-G,H,J,K,L,M,N,P,R operate from the voltage sources and are energized as soon as normal or emergency power is available. Contacts are rated for 10 amperes, 1/3 HP at 120 vac. See Figure 7-1 for accessory locations.

Accessory DD-14-G, ten-contact kit for remote indication has two contacts that indicate contactor is in the normal position and two contacts that indicate contactor is in the emergency position. Also included is one relay for each of the following: normal source present, emergency source present, ATS not in auto,

program switch not in off, system alarm, and load bank alarm. See Figure 7-2 for wiring connections.

### **NOTE**

One DD-14-G may be fitted to a transfer switch. A maximum of two DD-14-H through DD-14-R single-contact kits may be added in addition to the DD-14-G.

Accessory DD-14-H single-contact kit indicates contactor is in the normal position. See Figure 7-3 for wiring connections.

Accessory DD-14-J single-contact kit indicates contactor is in the emergency position. See Figure 7-3 for wiring connections.

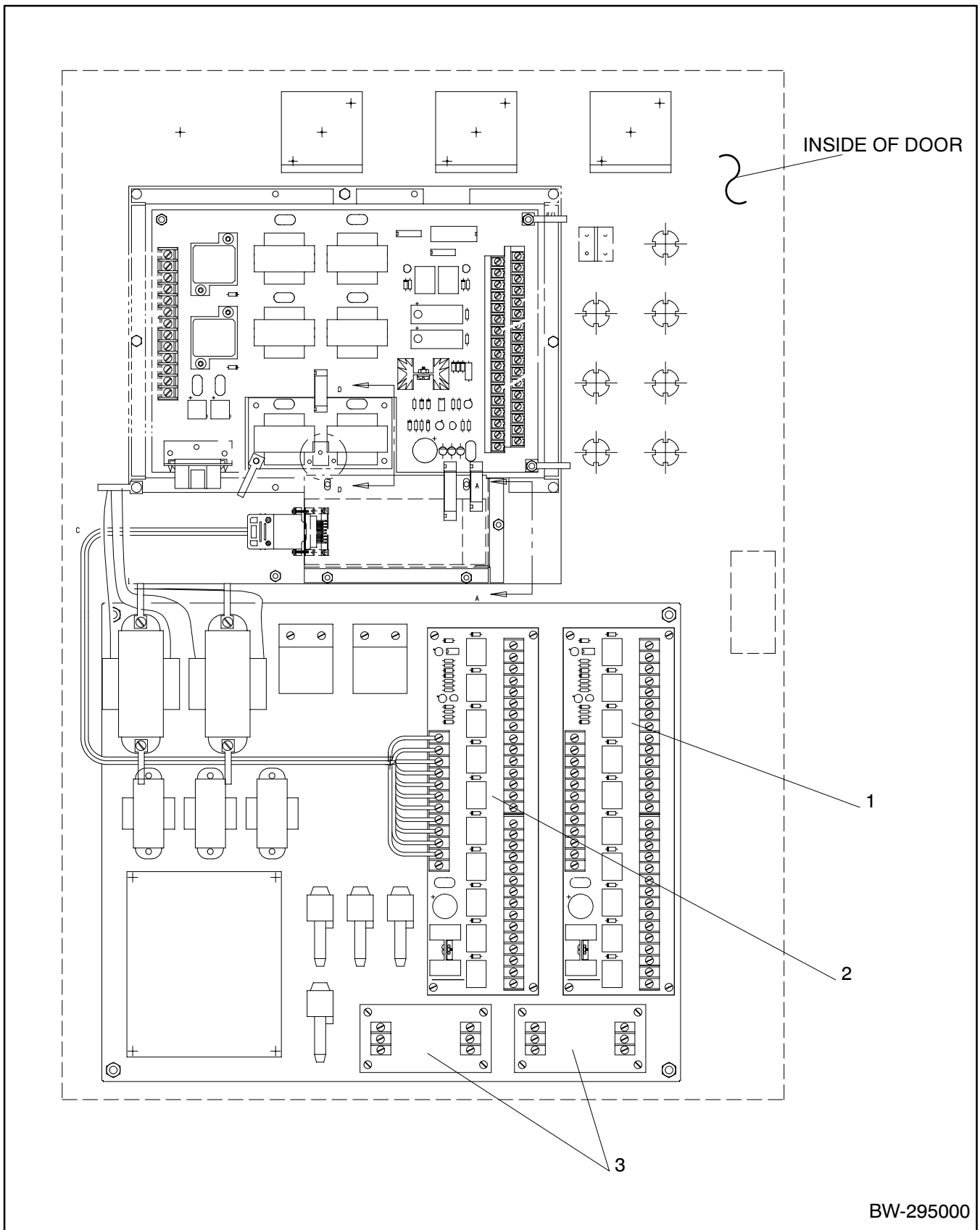

BW-295000

1. Accessory DD-14-G Auxiliary Contacts  
 2. Accessory DD-35-N Load-Shed

3. Accessories DD-14-H thru DD-14-R

**Figure 7-1. Accessory Locations**

Accessory DD-14-K single-contact kit indicates that the normal source is present. See Figure 7-3 for wiring connections.

Accessory DD-14-L single-contact kit indicates that the emergency source is present. See Figure 7-3 for wiring connections.

Accessory DD-14-M single-contact kit indicates the ATS is not in the auto position. See Figure 7-3 for wiring connections.

Accessory DD-14-N single-contact kit indicates that the Program switch is not in off position. See Figure 7-3 for wiring connections.

Accessory DD-14-P single-contact kit indicates that the system is in alarm. See Figure 7-3 for wiring connections.

Accessory DD-14-R single-contact kit indicates that there is a load bank alarm. See Figure 7-3 for wiring connections.

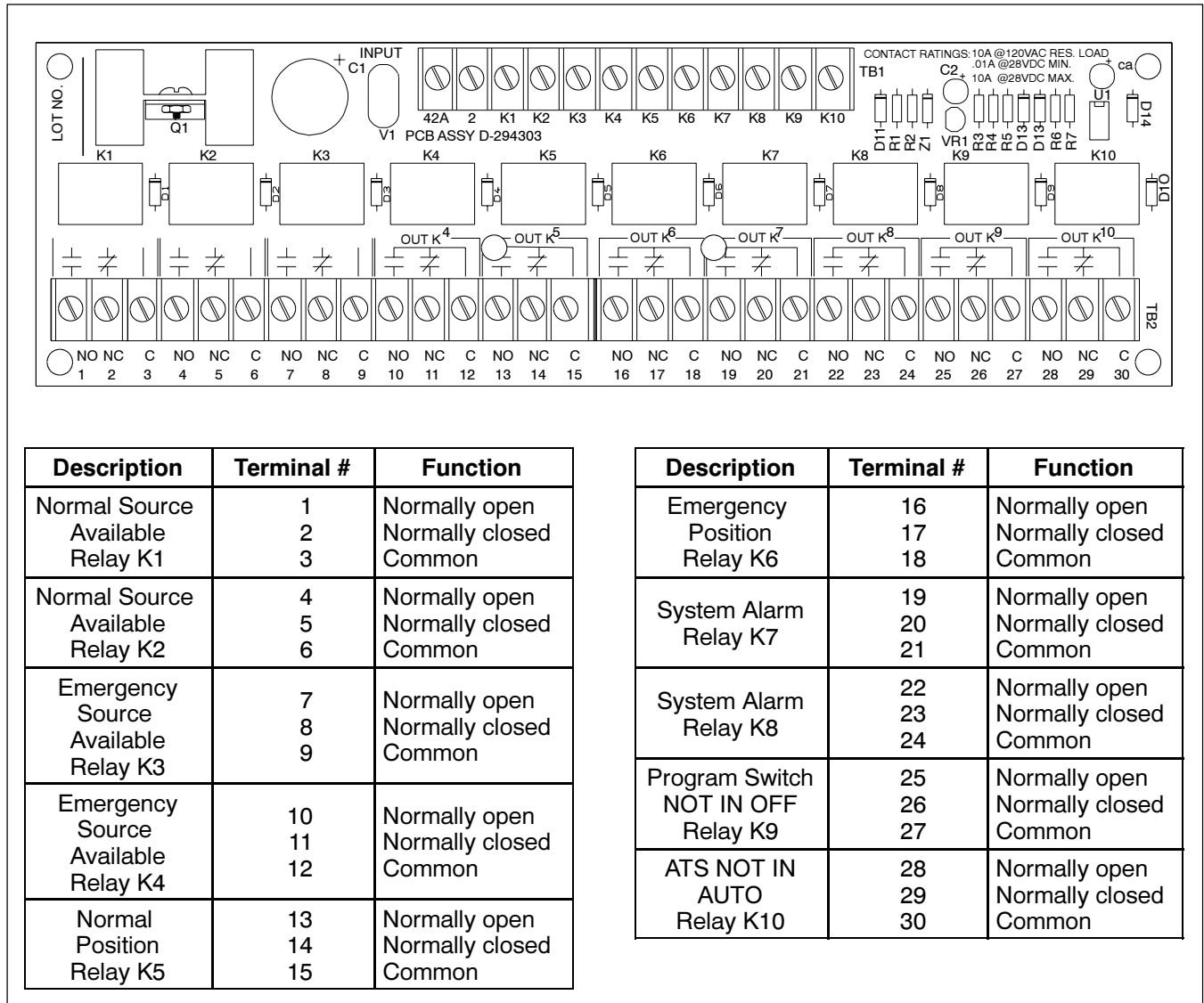
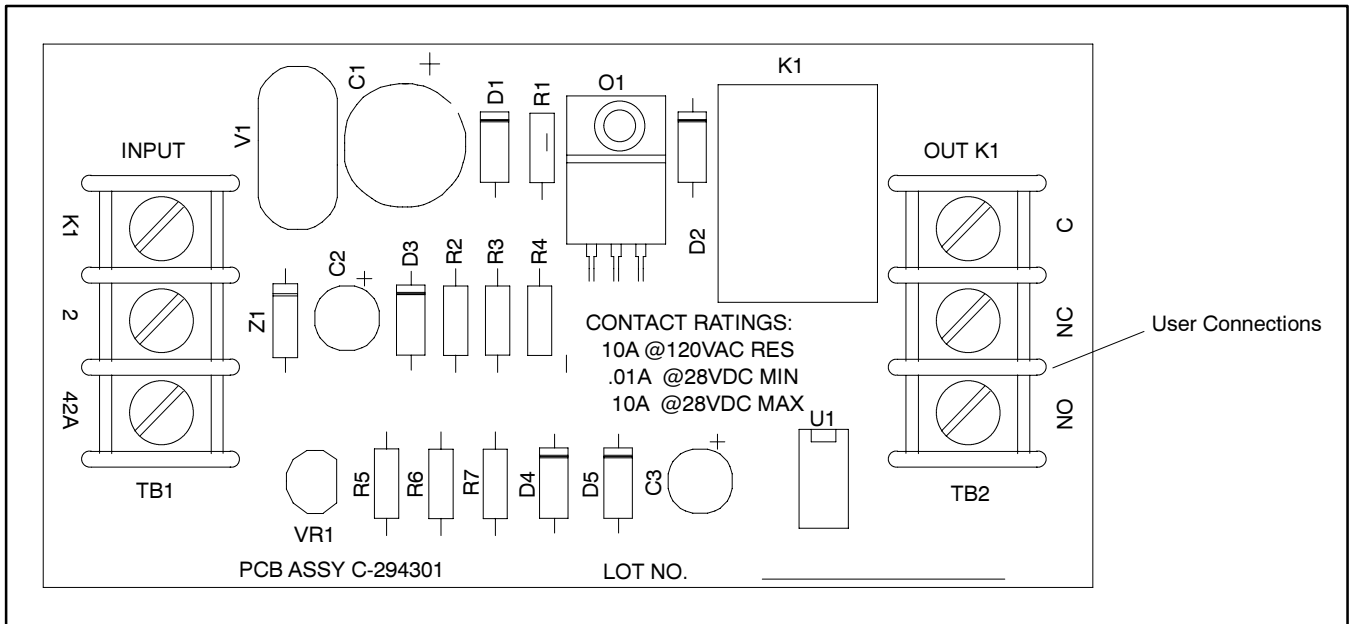

Figure 7-2. Wiring Connections Accessory DD-14-G



**Figure 7-3. Accessories DD-14-H through DD-14-R**

## Contact Position Auxiliary Contacts DD-15-E,F

This accessory is mounted on the power switching device. The location of the contacts varies according to the power switching device.

### NOTE

Not available for Bypass Isolation Transfer Switch.

Accessory DD-15-E has a single contact closed when the power switching device is connected to the normal source.

Accessory DD-15-F has a single contact closed when the power switching device is connected to the emergency source.

## Auxiliary Meters DD-18-G,J

Accessory DD-18-G is a fused analog frequency meter for the emergency source.

Accessory DD-18-J is a fused analog voltage meter for the normal and emergency sources. Also included is an analog ampere meter for measuring load current.

## Plant Exercisers DD-23-D,G

Accessories DD-23-D and G are programmable plant exercisers for periodic exercising of the emergency generator set.

Accessory DD-23-D simulates a normal source failure. The transfer switch transfers the load to the emergency source during the exercises. An override function is also included so the exercise can be ended at any time. User has a choice of 7-day, 14-day, or calendar-based exercise modes.

Accessory DD-23-G includes a two-position selector switch to select between Simulated Normal Failure (exercise generator under load) and Test Engine Only (exercise generator set without load). An override function is also included so the exercise can be ended at any time. User has a choice of 7-day, 14-day, or calendar-based exercise modes.

## Battery Chargers

### DD-24-xxA,B

Automatic battery chargers are mounted below the main circuit board on the enclosure door.

Accessory DD-24-xxA 12-volt output

Accessory DD-24-xxB 24-volt output

The xx above is a voltage and frequency code that does not always match the transfer switch voltage and frequency code in the model number because some battery chargers are designed to work with multiple voltages.

#### NOTE

The battery chargers included in the transfer switch covered by this manual are designed strictly for use in the transfer switch and conform with UL and CSA listing requirements where specified. Read instructions before using battery charger.

### Information Required Prior to Charging Battery

This charger is specifically designed for charging wet cell (lead-acid) batteries. Do not use this charger on any other batteries.

Give dry batteries a conditioning charge upon adding electrolyte fluid. Follow the battery manufacturer's recommendations for performing initial conditioning charge.

## To Connect/Disconnect Charger

**CHARGER DAMAGE!** Connect charger only to battery with the same DC voltage as the battery charger output rating.

1. Inspect battery for defective cables and loose posts or terminals. Battery terminals and battery charger clips must be tight and corrosion free for efficient battery charging.
2. Check fluid level in each cell; if low, add distilled water until fluid is at proper level. If using a sealed-type battery, no maintenance is required.
3. A battery may be charged without disconnecting it from the generator or disturbing the cables connected at the battery posts by making the connections as listed. See Figure 7-4.
  - a. Connect positive (+) charger terminal to battery positive (+) post and negative (-) charger terminal to battery negative (-) post. Consult local codes for proper wire size.
  - b. Connect to correct voltage 50/60 Hz, AC power source as indicated by nameplate or transfer switch wiring diagram.
4. The charge rate the charger is delivering to the battery is indicated on the ammeter. The charger control circuit limits the maximum charging current to two amps. No cranking disconnect is required due to the current limit protection feature.

5. A battery is charged when:

- a. Bubbles appear on the surface of the fluid as the battery reaches 80–85% of full charge. Vigorous bubbling occurs when nearing total charge.
- b. A battery in good condition has a specific gravity reading (using a hydrometer) between 1.250 and 1.285 at an electrolyte temperature of 80°F (26.7°C).
- c. The charging rate tapers to near zero as the battery becomes charged and the battery voltage approaches the control voltage setting.

6. To disconnect charger, first disconnect charger from AC power, then disconnect charger from the battery posts, first disconnecting the charger connection to battery negative (-).

## Voltage Control

The voltage of the charger was factory set to maintain a voltage of 13.2 volts for 12-volt-batteries or 26.4 volts for 24-volt batteries up to a maximum output current of two amps.

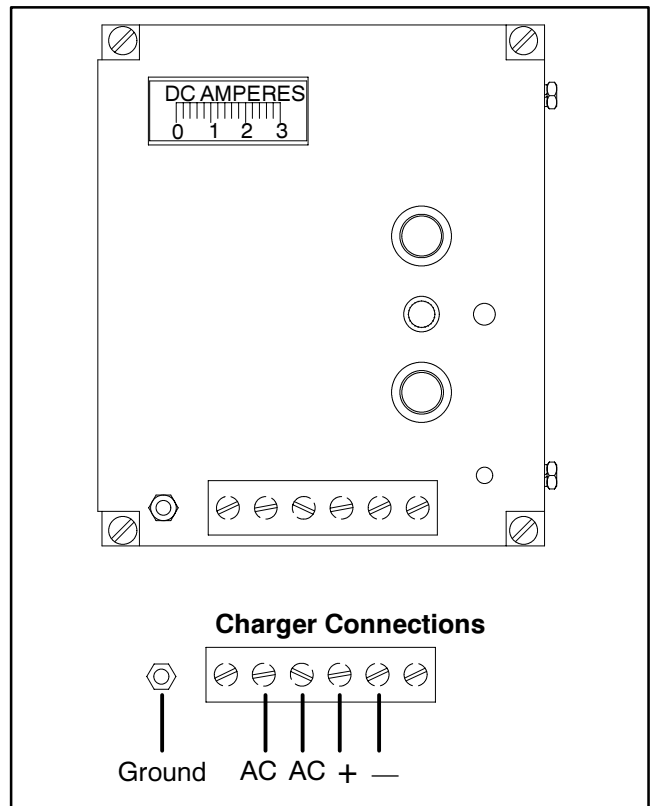

**Figure 7-4. Battery Charger User Connections**

### NOTE

Battery charger AC leads connect to TB-AC1-LA and TB-AC1-LC.

## Manual Switch Operation DD-29-P,R,S,T,U,V,W,X,Y

The accessory DD-29 allows manual operation of the transfer switch. DD-29 includes an override circuit which will cause the transfer switch to automatically transfer to the alternate power source if the connected source fails.

Accessory DD-29-P provides momentary contact buttons for manual transfer in both directions.

Accessory DD-29-R provides momentary contact key-operated switches for manual transfer in both directions.

Accessory DD-29-S provides momentary contact button for manual transfer from emergency to normal.

Accessory DD-29-T provides a momentary contact key-operated switch for manual transfer from emergency to normal.

Accessory DD-29-U provides momentary contact buttons for manual transfer in both directions and an automatic/manual selector switch.

Accessory DD-29-V provides momentary contact key-operated switches for manual transfer in both directions and an automatic/manual selector switch.

Accessory DD-29-W provides a momentary contact button for manual transfer from emergency to normal and an automatic/manual selector switch.

Accessory DD-29-X provides a key-operated switch for manual transfer from emergency to normal and an automatic/manual selector switch.

Accessory DD-29-Y provides a momentary contact button for manual transfer from emergency to normal and an automatic/manual selector switch with transfer to off.

## Transfer Mode Selector Switch DD-29

### AUTO Transfer Position

The AUTO position enables fully automatic transfer sequence in situations when the normal source is not acceptable or when testing transfer switch operation.

### MANUAL Transfer Position

When normal source fails:

1. Generator set will start after time delay. The emergency available LED will light.
2. Normal-to-emergency time delay will complete timing.
3. System alarm LED flashes.
4. LCD display will show MANUAL TRANSFER.
  - a. For nonprogrammed transition transfer switches, press the transfer-to-emergency button. The contactor will transfer to the emergency position.
  - b. For programmed transition transfer switches the LCD will display manual to off. Press the transfer to off pushbutton. The contactor will transfer to the off position.
5. Off-to-emergency time delay will complete timing.
6. LCD display will show manual transfer. Press the transfer-to-emergency button. The contactor will transfer to the emergency position.

When normal source returns:

1. Both source available LEDs will light.
2. Emergency-to-normal delay will complete timing.
3. LCD display will show MANUAL TRANSFER.
  - a. For nonprogrammed transition transfer switches system alert LED flashes. Press the transfer to normal button. The contactor will transfer to the off position.
  - b. For programmed transition switches system alert LED flashes and LCD will display manual to off. Press the transfer-to-off pushbutton. The contactor will transfer to the off position.
4. Off-to-normal time delay will complete timing.
5. LED will display MANUAL TRANSFER. Press the transfer-to-normal pushbutton. The contactor will transfer to the normal source.
6. Engine cooldown LED lights. Generator set begins time delay for cooldown.
7. Generator set shuts down as cooldown completes timing. Emergency available LED goes out.

DD-29 accessories also include a selector switch override circuit to automatically transfer if the connected source fails and the other source is available.

## Load-Shedding Contacts DD-35-N

Accessory DD-35-N allows the M340+ user to select specific loads which will receive power. This accessory can control from one to nine isolated relays before and after the transfer switch transfers from either normal source to emergency source or from emergency source to normal source. The contacts can be either transferred in a block or transferred sequentially in either direction. The time delays before transfer and the sequence interval time delay are adjustable. See Figure 7-1 for accessory location. See Figure 7-5 for wiring connections.

# Remote Communications Port Adapter DD-51-A,B

Accessories DD-51-A and B allow connection to an IBM-compatible personal computer for remote transfer switch monitoring.

Accessory DD-51-A provides an automatic transfer switch RS-485 port adapter board for direct or LAN connection.

Accessory DD-51-B provides an automatic transfer switch RS-232 port adapter board for modem connection.

Either DD-51-A or DD-51-B may be installed, but not both.

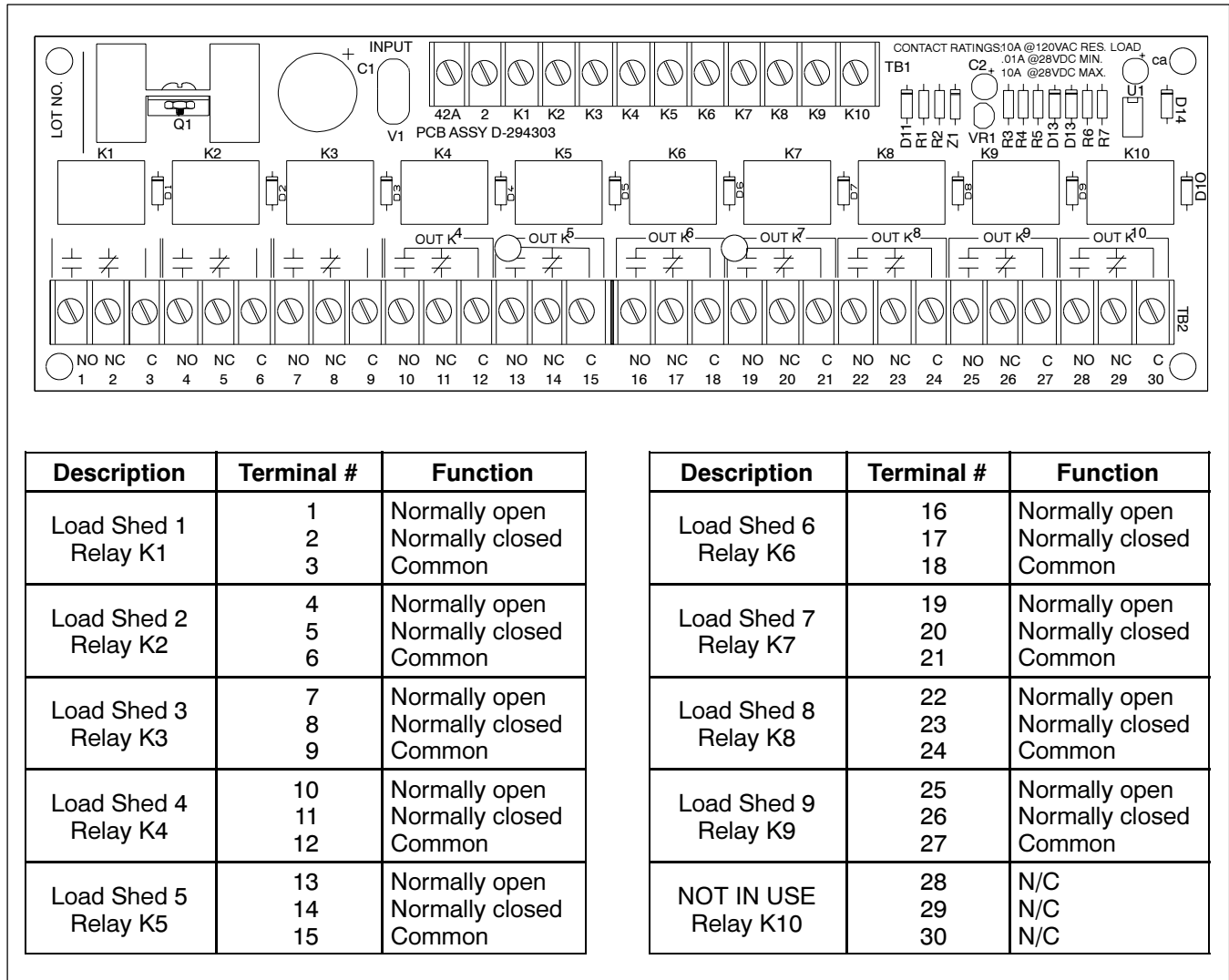

Figure 7-5. Load Shed Contacts Wiring Connections Accessory DD-35-N

# Appendix A. Glossary of Abbreviations

Abbreviations are used throughout this manual. Normally in the text they will appear in complete form with the abbreviation following in parenthesis the first

time they are used. After that they will appear in the abbreviated form. The commonly used abbreviations are shown below.

<b>Abbreviation</b>	<b>Description</b>	<b>Abbreviation</b>	<b>Description</b>
AC	alternating current	dept.	department
AHWT	anticipatory high water temp.	dia.	diameter
ALOP	anticipatory low oil pressure	e.g.	example given
AM	amplitude modulation	EMI	electromagnetic interference
Amp	ampere	etc.	etcetera, (and so forth)
Amps	amperes	ext.	external
ANSI	American National Standard Institute	°F	Fahrenheit degree
API	American Petroleum Institute	fl. oz.	fluid ounce, fluid ounces
approx.	approximate, approximately	FM	frequency modulation
A/R	as required, as requested	fs	full scale
A/S	as supplied, as stated, as suggested	ft.	foot, feet
ASA	American Standards Association	ft. lbs.	foot pound, foot pounds
assy.	assembly	ga.	gauge
ASTM	American Society for Testing Materials	gal., gals.	gallon, gallons
ATDC	after top dead center	gal./hr.	gallons per hour
ATS	automatic transfer switch	gph	gallons per hour
aux.	auxiliary	gpm	gallons per minute
AWG	American Wire Gauge	gr.	grade
AWM	appliance wiring material	grd.	ground
bhp	brake horsepower	HCHT	high cylinder head temperature
bmep	brake mean effective power	HET	high exhaust temperature
Btu	British thermal unit	Hg	mercury (element)
°C	Celsius degree	H <sub>2</sub> O	water
cc	cubic centimeter	hp	horsepower
CCA	cold cranking Amps.	hr, hrs	hour
CEC	Canadian Electrical Code	HWT	high water temperature
cfh	cubic feet per hour	Hz	hertz (cycles per second)
cfm	cubic feet per minute	ID	inside diameter
CID	cubic inch displacement	in.	inch(es)
cm	centimeter, centimeters	inc.	incorporated
cmm	cubic meters per minute	in. lbs.	inch pounds
co.	company	int.	internal
cont'd.	continued	int.-ext.	internal-external
C.S.A.	Canadian Standards Association	ISO	International Standards Organization
cu. in.	cubic inch, cubic inches	J	joule, joules
cyl.	cylinder	JIS	Japanese Industry Standard
dBA	decibels	kg	kilogram, kilograms
DC	direct current	kg/cm <sup>2</sup>	kilograms per square centimeter
DCR	direct current resistance	kgm	kilogram meter(s)
deg.	degree	km	kilometer, kilometers

<b>Abbreviation</b>	<b>Description</b>
kPa	kiloPascal, kiloPascals
kph	kilometers per hour
kV	kilovolt
kVA	kilovolt amperes
kW	kilowatt, kilowatts
kWH	kilowatt hour
L	liter, liters
LxWxH	length x width x height
LED, LEDs	light emitting diode
lb., lbs.	pound, pounds
L/hr.	liter per hour, liters per hour
L/min.	liter(s) per minutes
LOP	low oil pressure
LP	liquefied petroleum
LWT	low water temperature
m	meter, meters
m <sup>3</sup>	cubic meter, cubic meters
max.	maximum
MCM	one thousand circular mils.
mi.	mile, miles
mil	one one-thousandth of an inch
min.	minimum
mJ	millijoule, millijoules
MJ	mega joule, mega joules
mm	millimeter, millimeters
m <sup>3</sup> /min	cubic meters per minute
MPa	megaPascal
mph	miles per hour
MS	military standard
mW	milliwatt, milliwatts
MW	megawatt, megawatts
N/A	not available
NEC	National Electrical Code
NEMA	National Electrical Manufacturers Association
NFPA	National Fire Protection Association
Nm	Newton meter, Newton meters
no., nos.	number, numbers
NPT	National Standard taper pipe

<b>Abbreviation</b>	<b>Description</b>
	thread per general use
N/R	not required
OC	overcrank
OD	outside diameter
OEM	original equipment manufacturer
OS	overspeed, oversize
OV	overvoltage
oz.	ounce, ounces
PF	power factor
pot.	potentiometer
ppm	parts per million
psi	pounds per square inch
pt., pts.	pint, pints
qt., qts.	quart, quarts
qty.	quantity
ref.	reference
RFI	radio frequency interference
rms	root mean square
rpm	revolutions per inch
SAE	Society of Automotive Engineers
sec.	second, seconds
SCR	silicon controlled rectifier
spec, specs	specification
sq.	square
sq. cm	square centimeters
sq. in.	square inch, square inches
tach	tachometer
TDC	top dead center
temp.	temperature
TIF	telephone influence factor
turbo	turbocharger
UNC	Unified coarse thread (was NC)
UNF	Unified fine thread (was NF)
UL	Underwriter's Laboratories, Inc.
US	undersize
V	volt, volts
VAC	Volts alternating current
VDC	volts direct current
W	watt, watts

# Appendix B. Source History Message Summary

## Single Phase

NORM OVER VOLT	Normal source was detected to be over the voltage dropout range.
NORM UNDER VOLT	Normal source was detected to be under the voltage dropout range.
NORM OVER FREQ	Normal source was detected to be over the frequency dropout range.
NORM UNDER FREQ	Normal source was detected to be under the frequency dropout range.
EMER OVER VOLT	Emergency source was detected to be over the voltage dropout range.
EMER UNDER VOLT	Emergency source was detected to be under the voltage dropout range.
EMER OVER FREQ	Emergency source was detected to be over the frequency dropout range.
EMER UNDER FREQ	Emergency source was detected to be under the frequency dropout range.

## Three Phase

N-OVVOLT PH A-B	Normal source was detected to be over the voltage dropout range between legs A and B.
N-OVVOLT PH B-C	Normal source was detected to be over the voltage dropout range between legs B and C.
N-OVVOLT PH A-C	Normal source was detected to be over the voltage dropout range between legs A and C.
N-UNVOLT PH A-B	Normal source was detected to be under the voltage dropout range between legs A and B.
N-UNVOLT PH B-C	Normal source was detected to be under the voltage dropout range between legs B and C.
N-UNVOLT PH A-C	Normal source was detected to be under the voltage dropout range between legs A and C.
N-OVER FREQ	Normal source was detected to be over the frequency dropout range.
N-UNDER FREQ	Normal source was detected to be under the frequency dropout range.
N-PHASE LOSS	One of the three phases is detected as non-energized.
E-OVVOLT PH A-B	Emergency source was detected to be over the voltage dropout range between legs A and B.
E-OVVOLT PH B-C	Emergency source was detected to be over the voltage dropout range between legs B and C.
E-OVVOLT PH A-C	Emergency source was detected to be over the voltage dropout range between legs A and C.
E-UNVOLT PH A-B	Emergency source was detected to be under the voltage dropout range between legs A and B.
E-UNVOLT PH B-C	Emergency source was detected to be under the voltage dropout range between legs B and C.
E-UNVOLT PH A-C	Emergency source was detected to be under the voltage dropout range between legs A and C.
E-OVER FREQ	Emergency source was detected to be over the frequency dropout range.
E-UNDER FREQ	Emergency source was detected to be under the frequency dropout range.
E-PHASE LOSS	One of the three phase is detected as non energized.

# Appendix C. System Alert Message Summary

<b>AUX-SWITCH FAULT</b>	Contactactor malfunction or limit switch fault.
<b>DBL AUX-SW FAULT</b>	Contactactor limit switch fault.
<b>TRANSFER HANG</b>	Contactactor transfer time too long or failure to transfer.
<b>POWER-DOWN ERROR</b>	Internal controller fault.
<b>RAM ERROR</b>	Internal controller fault.
<b>MEMORY ERROR</b>	Internal controller fault.
<b>MANUAL TRANSFER</b>	Controller is ready to accept input from manual transfer pushbuttons (if equipped).
<b>MANUAL TO OFF</b>	Controller is ready to accept input from manual transfer pushbuttons.
<b>FAULT #1</b>	Annunciation of fault signal from a remote source, such as an engine condition switch, customer chosen and connected.
<b>FAULT #2</b>	Annunciation of fault signal from a remote source, such as an engine condition switch, customer chosen and connected.

# Appendix D. Setting Ranges

<b>Time Delays (Index 5)</b> (Minutes:Seconds)	<b>Standard Range</b>	<b>Maximum with Extended Time Delay</b>	<b>Factory Setting</b>
Time Delay Engine Start (TDES)	0-6 seconds;	99:00	5 seconds
Time Delay Normal to Emergency (TDNE)	0-5 minutes;	99:00	5 seconds
Time Delay Emergency to Normal (TDEN)	0-30 minutes;	99:00	5 seconds
Time Delay Engine Cooldown (TDEC)	0-30 minutes;	99:00	5 seconds
Time Delay Off to Normal	0-2 minutes;	99:00	1 second
Time Delay Off to Emergency	0-2 minutes;	99:00	1 second

## **Normal Voltage/Frequency Settings and Trip Points (Index 6)**

Normal Volts	105-600	-
Normal Hz	48-62	-
Normal Overvoltage Dropout %	105-135%	115%
Normal Overvoltage Pickup %	100-130%	110%
Normal Undervoltage Pickup %	75-100%	90%
Normal Undervoltage Dropout %	70-95%	85%
Normal Overfrequency Dropout %	105-135%	115%
Normal Overfrequency Pickup %	100-130%	110%
Normal Underfrequency Pickup %	85-100%	90%
Normal Underfrequency Dropout %	80-95%	85%

## **Emergency Voltage/Frequency Settings and Trip Points (Index 7)**

Emergency Volts	105-600	-
Emergency Hz	48-62	-
Emergency Overvoltage Dropout %	105-135%	115%
Emergency Overvoltage Pickup %	100-130%	110%
Emergency Undervoltage Pickup %	75-100%	90%
Emergency Undervoltage Dropout %	70-95%	85%
Emergency Overfrequency Dropout %	105-135%	115%
Emergency Overfrequency Pickup %	100-130%	110%
Emergency Underfrequency Pickup %	85-100%	90%
Emergency Underfrequency Dropout %	80-95%	85%

## **Plant Exerciser (Index 8)**

Modes	7-day
Run Hours 0-4:00 Hours:Minutes	-
Run Hours 0-72:00 Hours:Minutes, returns to 00:00 after timeout	-

## **Load Shed (Index 9)** (Minutes:Seconds)

Before	0-60 seconds;	99:00	00:00
After	0-5 seconds;	99:00	00:00
Sequence	0-5 seconds;	99:00	00:00
Loads Return 1-9			9

# Appendix E. Initial Setup Worksheets

## Checking Installed Control Options

Review the accessories furnished with the transfer switch. Access Index 11 and use the *M340+ Operation and Installation* manual (TP-5664) *Off/Monitor Mode*

for guidance through the procedure. Enter the enabled features indicated on the following worksheet. See Figure A-1.

Installed Control Options Worksheet		
Control Option	Enabled YES or NO	
INPHASE MON	_____	Inphase monitor.
PHA SEQ/LOSS	_____	Source phase sequence (3 phase applications only).
NORM & EMER	_____	Normal and emergency: for use in overvoltage and undervoltage and frequency sensing.
PLANT EXERC	_____	Programmed periodic generator set exerciser.
TD EXTENDED	_____	Extended (to 99 minutes maximum) time delay.
MAN OVERRIDE	YES	Automatic override of all possible manual functions to provide power to the load.
TD OFF	_____	Off position time delays.

Figure A-1. Install Control Options Worksheet

## Time Delays

Fill out this worksheet by entering the desired time delay settings in minutes and seconds (MN:SE). Then follow the instructions in the *M340+ Operation and Installation*

manual (TP-5664) *Local/Programming Mode*, if any settings need to be changed. See Figure A-2.

Time Delay Worksheet				
Time Delay Function	Factory Setting	Normal Limit	# Extended Limit	New Setting
Engine Start (TDES)	00:05	0-00:06	99:00	____:____
Normal to Emergency (TDNE)	00:05	0-05:00	99:00	____:____
Emergency to Normal (TDEN)	00:05	0-30:00	99:00	____:____
Engine Cooldown (TDEC)	00:05	0-30:00	99:00	____:____
Off to Normal (TDOE)	00:01	0-02:00	99:00	____:____
Off to Emergency (TDON)	00:01	0-02:00	99:00	____:____

Figure A-2. Time Delay Worksheet

**NOTE**

It is possible to set the time delay on engine start as long as 99 minutes. But a TDES setting of longer than 6 seconds (00:06) without a battery backup is not recommended.

Set the longer delay in the TDNE to increase delay before switch transfers the load. Then the generator set will be running, supplying power to the timing function, and able to assume the load as soon as the timing has completed.

## Normal and Emergency System Set Points

Review load protection requirements for voltage and frequency levels needed. Then decide necessary pickup and dropout settings for transfer switch operation.

Enter these necessary settings into the following worksheet. Access Index 9 and use the *M340+ Operation and Installation* manual (TP-5664) *Local/Programming Mode* for guidance through setting procedures. See Figure A-3.

	Setting	Factory Setting		New Setting	
	Limits	Normal	Emergency	Normal	Emergency
Overvolt Dropout	105-135%	115%	115%	____%	____%
Overvolt Pickup	100-130%	110%	110%	____%	____%
Undervolt Pickup	75-100%	90%	90%	____%	____%
Undervolt Dropout	70-95%	85%	85%	____%	____%
Underfreq Dropout	105-135%	115%	115%	____%	____%
Overfreq Pickup	100-130%	110%	110%	____%	____%
Underfreq Pickup	85-100%	90%	90%	____%	____%
Underfreq Dropout	80-95%	85%	85%	____%	____%

**Figure A-3. Set Point Worksheet**

# Plant Exerciser Settings

There are three different plant exercisers that can be used. Only one of the following may be selected for use at any one time.

- **7-Day or weekly exerciser** provides exercise events that will happen at the same time, on the same day(s), and for the same duration every week. See Figure A-4.
- **14-Day or two-week exerciser** provides exercise events that will happen at the same time, on the same day(s), and for the same duration every other week. These can be programmed to provide weekly exercise events as well. See Figure A-4.
- **Calendar exerciser** allows exercise on any two times that the day of the week occurs in a month. The calendar exerciser is a true calendar type, and

it knows when a day of the week will occur in any given month once the date has been set in Index 4. See Figure A-5.

All three exerciser types allow up to five *exercise events* to be programmed. With two *exercise periods* possible for each event, each exerciser type allows up to ten exercise periods to be programmed.

The choice of exercising the generator set either under load or unloaded is selectable only if option DD-23-G has been installed. If this option is installed, check the selector toggle switch's position to see whether the generator set will be exercised under load or unloaded. The load/no-load switch is located on the inside of the transfer switch door.

7-Day Exerciser Worksheet						
Event #	Start Time		Day of Week		Run Time	
	Yes?	HR:MN	AM/PM	1st Day	2nd Day	HR:MN
1	_____	____:____	___	_____	_____	____:____
2	_____	____:____	___	_____	_____	____:____
3	_____	____:____	___	_____	_____	____:____
4	_____	____:____	___	_____	_____	____:____
5	_____	____:____	___	_____	_____	____:____

14-Day Exerciser Worksheet							
Event #	Start Time		Day of Week		Week	Run Time	
	Yes?	HR:MN	AM/PM	1st Day	2nd Day	1 or 2	HR:MN
1	_____	____:____	___	_____	_____	_____	____:____
2	_____	____:____	___	_____	_____	_____	____:____
3	_____	____:____	___	_____	_____	_____	____:____
4	_____	____:____	___	_____	_____	_____	____:____
5	_____	____:____	___	_____	_____	_____	____:____

Figure A-4. 7-Day and 14-Day Exerciser Worksheets

Calendar Exerciser Worksheet						
Event # Yes?	Start Time		Day of Week	Occurrence #Run Time		
	HR:MN	AM/PM		1st	2nd	HR:MN
1 _____	____:____	____	_____	_____	_____	____:____
2 _____	____:____	____	_____	_____	_____	____:____
3 _____	____:____	____	_____	_____	_____	____:____
4 _____	____:____	____	_____	_____	_____	____:____
5 _____	____:____	____	_____	_____	_____	____:____

Figure A-5. Calendar Exerciser Worksheet

## Load-Shed Settings

Review load-shedding requirements for loads connected to the system. Then determine necessary times (in minutes and seconds) before and after transfer to either source that particular blocks of load are to be disconnected. Also determine the time (in minutes and seconds) that needs to elapse between shed-return operations. Determine the number of load blocks (1-9) that are to be reconnected after transfer to the emergency source. Enter these settings into the

following worksheet. Access Index 9 and use the *M340+ Operation and Installation* manual (TP-5664), *Local/Programming Mode* for guidance through setting procedures. See Figure A-6.

### NOTE

Standard time ranges are shown below. If extended time delay is enabled, the maximum setting is 99 minutes.

Load-Shed Worksheet			
Load Shed	Standard Range	Normal	Emergency
		MN:SC	MN:SC
Time Before	0-60 Sec.	____:____	____:____
Time After	0-5 Sec.	____:____	____:____
Time Sequence	0-5 Sec.	____:____	____:____
Loads to Return	1-9	____	____

Figure A-6. Load-Shed Worksheet

# Notes

# Index

## A

Accessory Active, 2-2, 7-1  
Area Protection, 1-4, 2-2  
Inphase Monitor, 1-5, 2-2  
Load Shed, 2-2  
Plant Exerciser, 1-5, 2-2  
Area Protection, 1-4

## B

Bypass  
E-N Time Delay, 2-3  
N-E Time Delay, 2-3

## C

Calibration, Setup, 4-29  
Contactor, Position LED, 2-7  
Contactor, position LED, 2-1  
Control Options, 4-27, A-6  
Control Switches, 2-3

## D

Date, 3-3  
setting, 4-8, 5-8  
Day, 4-8  
Day Occurs, 4-8, 5-9

## E

Emergency Source, set points, 5-16  
Emergency Source setpoints, 4-13  
Emergency Source Settings, 5-16  
Emergency Source settings, 4-13  
Emergency System, 4-15, 5-16  
Emergency Voltage & Frequency,  
4-15, 5-16, A-5  
Engine start mode, 4-23  
Exer Stop Key, 3-2, 4-23

## L

LED Indicators, 2-1  
Load Shed, 4-24  
Settings, 5-31, A-5, A-9  
Setup, 5-31, A-9  
setup, 4-24

## N

Normal Source setpoints, 4-10, 5-12  
Normal Source Settings, 4-1, 4-10, 5-2, 5-12  
Normal Source Voltage and Frequency, 3-3  
Normal System, 4-10, 5-12  
Normal Voltage & Frequency, 4-2, 5-3, A-5

## P

Plant Exerciser  
Settings, 4-16, A-5, A-8  
14-day mode, 4-19  
7-day mode, 4-21  
Calendar Mode, 4-17, 5-21  
settings, 5-20  
Setup, 4-16  
14-day mode, 5-24  
7-day mode, 5-27  
engine-start mode, 5-29  
setup, 5-20  
Programming Mode Switch, 2-2, 3-2  
Local, 2-2, 3-1, 5-1  
Off, 2-2, 3-1, 4-1  
Remote, 3-1  
Programming Mode Switch, Remote, 2-2, 6-1

## R

Records, resetting, 4-6, 5-6  
Remote Control, 4-30, 5-36  
local Area network, 4-30  
local area network, 6-1  
local area network setup, 5-36  
local single connection, 4-30, 6-1  
remote local area network, 4-31  
remote local area network setup, 5-37  
remote single connection, 4-30, 6-1  
remote single connection setup, 5-36  
Setup, 4-30, 5-36

## S

Settings, 2-2

Source History, 4-26, 5-33

Source, LED, 2-1

System Status, 2-1

Not in Automatic, 2-1

Programming Mode Not in Off, 2-1

System Alert, 2-1

## T

Test Pushbutton, 2-3

Time, 3-3, 4-8

setting, 5-8

Time Delay

Emergency to Normal, 4-9

Engine Cooldown, 4-9

Normal to Emergency, 4-9

setting, 4-9

Time Delays, 2-2, 4-9, 5-10, A-5

Engine Cooldown, 2-2, 2-9

Engine Start, 2-2, 2-9, 4-9

Normal to Emergency, 2-2, 2-9

setting, 5-10

emergency-to-normal, 2-9, 5-10

engine cooldown, 5-11

engine start, 5-10

normal-to-emergency, 5-10

Time Delays Emergency to Normal, 2-2

Transfer Mode Selector Switch, 7-8

Auto Transfer Position, 7-8

Manual Position, 7-8



**TP-5664 6/94c**

© Kohler Co., 1994. All rights reserved.

# **KOHLER**<sup>®</sup> POWER SYSTEMS

KOHLER CO. Kohler, Wisconsin 53044  
Phone 920-565-3381, Web site [www.kohlergenerators.com](http://www.kohlergenerators.com)  
Fax 920-459-1646 (U.S.A. Sales), Fax 920-459-1614 (International)  
For the nearest sales and service outlet in U.S.A. and Canada  
Phone 1-800-544-2444

Kohler<sup>®</sup> Power Systems  
Asia Pacific Headquarters  
7 Jurong Pier Road  
Singapore 619159  
Phone (65)264-6422, Fax (65)264-6455