

Service and Parts

Automatic Transfer Switches

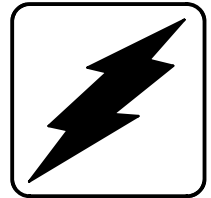

Models:

RDT
SE-ILC

Electrical Controls:
MPAC™ 500

Power Switching Device:
Contactors:
100-400 Amperes

ISO 9001
KOHLER
GENERATORS
INTERNATIONALLY REGISTERED

KOHLER[®]
POWER SYSTEMS

TP-6346 12/05

Table of Contents

Safety Precautions and Instructions	5
Introduction	9
List of Related Materials	9
Service Assistance	10
Section 1 Specifications and Service Views	11
1.1 Specifications	11
1.2 Transfer Switch Components	12
Section 2 Operation	15
2.1 Introduction	15
2.2 Controls	15
2.3 Test Sequence	16
2.4 Exerciser Setup	17
2.4.1 Standard Exerciser	17
2.4.2 Exerciser Options	17
2.5 Sequence of Operation	18
2.5.1 Source Sensing	18
2.5.2 Powerup/Reset Sequence	18
2.5.3 Transfer Sequence	19
2.5.4 Test Sequence	20
2.5.5 Exercise Sequence	21
2.6 Manual Operation	22
Section 3 Scheduled Maintenance	23
3.1 Introduction	23
3.2 Inspection and Service	24
3.2.1 General Inspection	24
3.2.2 Internal Inspections and Maintenance	25
3.3 Testing	27
3.3.1 Weekly Generator Set Exercise	27
3.3.2 Monthly Automatic Operation Test	27
3.3.3 Other Tests	27
3.4 Service Schedule	29
Section 4 Troubleshooting	31
4.1 Initial Troubleshooting	32
4.2 Troubleshooting Charts	32
4.3 Faults	40
4.3.1 Failure to Acquire Emergency Source Warning	40
4.3.2 Failure to Transfer Warning	40
4.3.3 Auxiliary Switch Fault	40
4.4 Resetting the Controller	40
4.4.1 Fault Reset	40
4.4.2 Controller Reset	40
4.4.3 Alarm Silence	40
4.5 Transfer Switch Troubleshooting	42
4.5.1 Neutral Connection	42
4.5.2 Mechanical Check	42
4.5.3 Solenoid Troubleshooting	42
Section 5 Component Testing	43
5.1 System Power	44
5.2 Normal Source Sensing	46
5.3 Emergency Source Sensing	47
5.4 Controller Operation Test	49
5.5 Controller Monitoring Using Hyper Terminal	50

Table of Contents, continued

5.6	Controller Application Code	51
5.7	Switch/LED Membrane	51
5.8	Engine Start Contact Test	52
5.9	Position-Indicating Microswitches	53
5.10	Solenoid Coil Testing	55
5.10.1	Coil-Operation Control Switches (400 amp transfer switches)	56
5.10.2	Operating Sequence Diagrams	57
5.11	Accessory Board	60
5.12	External Alarm Module (EAM)	62
Section 6 Drawings and Diagrams		63
Section 7 Service Part Replacement		71
7.1	Before and After Servicing Components	72
7.2	Circuit Board Handling	72
7.3	Controller Circuit Board Replacement	73
7.4	Contactor Assembly Removal and Installation	76
7.4.1	Contactor Assembly Removal	76
7.4.2	Contactor Assembly Installation	76
7.5	100–200 Amp Model Service	77
7.5.1	Solenoid Assembly	77
7.5.2	Solenoid Assembly Installation	78
7.5.3	Microswitch Replacement	79
7.6	400 Amp Model Service	81
7.6.1	Disassembly/Reassembly	81
7.6.2	Circuit Board Replacement	83
7.6.3	Closing Coil Replacement	84
7.6.4	Auxiliary Switch Replacement	85
7.7	Other Service Parts	86
7.7.1	Other Service Part Removal	86
Section 8 Service Parts		87
8.1	Finding Parts Information	87
8.2	Leads	87
8.3	Common Hardware	87
8.4	Transfer Switch Model Designation	88
8.5	Parts Lists	88
Appendix A Abbreviations		99
Appendix B Common Hardware Application Guidelines		101
Appendix C General Torque Specifications		102
Appendix D Common Hardware Identification		103
Appendix E Common Hardware List		104

Safety Precautions and Instructions

IMPORTANT SAFETY INSTRUCTIONS. Electromechanical equipment, including generator sets, transfer switches, switchgear, and accessories, can cause bodily harm and pose life-threatening danger when improperly installed, operated, or maintained. To prevent accidents be aware of potential dangers and act safely. Read and follow all safety precautions and instructions. **SAVE THESE INSTRUCTIONS.**

This manual has several types of safety precautions and instructions: Danger, Warning, Caution, and Notice.

DANGER

Danger indicates the presence of a hazard that **will cause severe personal injury, death, or substantial property damage.**

WARNING

Warning indicates the presence of a hazard that **can cause severe personal injury, death, or substantial property damage.**

CAUTION

Caution indicates the presence of a hazard that **will or can cause minor personal injury or property damage.**

NOTICE

Notice communicates installation, operation, or maintenance information that is safety related but not hazard related.

Safety decals affixed to the equipment in prominent places alert the operator or service technician to potential hazards and explain how to act safely. The decals are shown throughout this publication to improve operator recognition. Replace missing or damaged decals.

Accidental Starting

WARNING

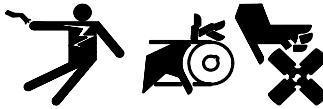

**Accidental starting.
Can cause severe injury or death.**

Disconnect the battery cables before working on the generator set. Remove the negative (-) lead first when disconnecting the battery. Reconnect the negative (-) lead last when reconnecting the battery.

Disabling the generator set. Accidental starting can cause severe injury or death. Before working on the generator set or connected equipment, disable the generator set as follows: (1) Move the generator set master switch to the OFF position. (2) Disconnect the power to the battery charger. (3) Remove the battery cables, negative (-) lead first. Reconnect the negative (-) lead last when reconnecting the battery. Follow these precautions to prevent starting of the generator set by an automatic transfer switch, remote start/stop switch, or engine start command from a remote computer.

Battery

WARNING



**Sulfuric acid in batteries.
Can cause severe injury or death.**

Wear protective goggles and clothing. Battery acid may cause blindness and burn skin.

Battery electrolyte is a diluted sulfuric acid. Battery acid can cause severe injury or death. Battery acid can cause blindness and burn skin. Always wear splashproof safety goggles, rubber gloves, and boots when servicing the battery. Do not open a sealed battery or mutilate the battery case. If battery acid splashes in the eyes or on the skin, immediately flush the affected area for 15 minutes with large quantities of clean water. Seek immediate medical aid in the case of eye contact. Never add acid to a battery after placing the battery in service, as this may result in hazardous spattering of battery acid.

WARNING





**Explosion.
Can cause severe injury or death.
Relays in the battery charger
cause arcs or sparks.**

Locate the battery in a well-ventilated area. Isolate the battery charger from explosive fumes.

Battery gases. Explosion can cause severe injury or death. Battery gases can cause an explosion. Do not smoke or permit flames or sparks to occur near a battery at any time, particularly when it is charging. Do not dispose of a battery in a fire. To prevent burns and sparks that could cause an explosion, avoid touching the battery terminals with tools or other metal objects. Remove all jewelry before servicing the equipment. Discharge static electricity from your body before touching batteries by first touching a grounded metal surface away from the battery. To avoid sparks, do not disturb the battery charger connections while the battery is charging. Always turn the battery charger off before disconnecting the battery connections. Ventilate the compartments containing batteries to prevent accumulation of explosive gases.

Hazardous Voltage/ Electrical Shock

⚠ DANGER

Hazardous voltage. Will cause severe injury or death.
Disconnect all power sources before opening the enclosure.

⚠ WARNING

Hazardous voltage. Moving rotor. Can cause severe injury or death.
Operate the generator set only when all guards and electrical enclosures are in place.

Grounding electrical equipment. Hazardous voltage can cause severe injury or death. Electrocution is possible whenever electricity is present. Open the main circuit breakers of all power sources before servicing the equipment. Configure the installation to electrically ground the generator set, transfer switch, and related equipment and electrical circuits to comply with applicable codes and standards. Never contact electrical leads or appliances when standing in water or on wet ground because these conditions increase the risk of electrocution.

Connecting the battery and the battery charger. Hazardous voltage can cause severe injury or death. Reconnect the battery correctly, positive to positive and negative to negative, to avoid electrical shock and damage to the battery charger and battery(ies). Have a qualified electrician install the battery(ies).

Making line or auxiliary connections. Hazardous voltage can cause severe injury or death. To prevent electrical shock deenergize the normal power source before making any line or auxiliary connections.

Servicing the transfer switch. Hazardous voltage can cause severe injury or death. Deenergize all power sources before servicing. Open the main circuit breakers of all transfer switch power sources and disable all generator sets as follows: (1) Move all generator set master controller switches to the OFF position. (2) Disconnect power to all battery chargers. (3) Disconnect all battery cables, negative (-) leads first. Reconnect negative (-) leads last when reconnecting the battery cables after servicing. Follow these precautions to prevent the starting of generator sets by an automatic transfer switch, remote start/stop switch, or engine start command from a remote computer. Before servicing any components inside the enclosure: (1) Remove all jewelry. (2) Stand on a dry, approved electrically insulated mat. (3) Test circuits with a voltmeter to verify that they are deenergized.

Servicing the transfer switch controls and accessories within the enclosure. Hazardous voltage can cause severe injury or death. Disconnect the transfer switch controls at the inline connector to deenergize the circuit boards and logic circuitry but allow the transfer switch to continue to supply power to the load. Disconnect all power sources to accessories that are mounted within the enclosure but are not wired through the controls and deenergized by inline connector separation. Test circuits with a voltmeter to verify that they are deenergized before servicing.

⚠ DANGER

Hazardous voltage. Will cause severe injury or death.
Disconnect all power sources before opening the enclosure.

⚠ DANGER

Hazardous voltage. Will cause severe injury or death.
Only authorized personnel should open the enclosure.

Short circuits. Hazardous voltage/current can cause severe injury or death. Short circuits can cause bodily injury and/or equipment damage. Do not contact electrical connections with tools or jewelry while making adjustments or repairs. Remove all jewelry before servicing the equipment.

Testing live electrical circuits. Hazardous voltage or current can cause severe injury or death. Have trained and qualified personnel take diagnostic measurements of live circuits. Use adequately rated test equipment with electrically insulated probes and follow the instructions of the test equipment manufacturer when performing voltage tests. Observe the following precautions when performing voltage tests: (1) Remove all jewelry. (2) Stand on a dry, approved electrically insulated mat. (3) Do not touch the enclosure or components inside the enclosure. (4) Be prepared for the system to operate automatically. (600 volts and under)

Heavy Equipment

⚠ WARNING

Unbalanced weight. Improper lifting can cause severe injury or death and equipment damage.
Use adequate lifting capacity. Never leave the transfer switch standing upright unless it is securely bolted in place or stabilized.

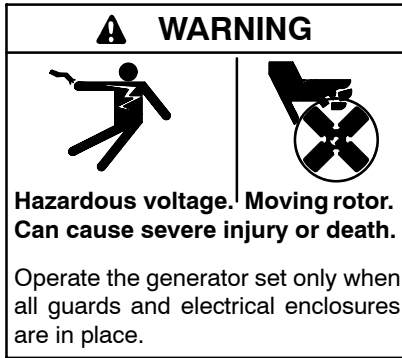
Moving Parts



Notice

NOTICE

Hardware damage. The transfer switch may use both American Standard and metric hardware. Use the correct size tools to prevent rounding of the bolt heads and nuts.

NOTICE

When replacing hardware, do not substitute with inferior grade hardware. Screws and nuts are available in different hardness ratings. To indicate hardness, American Standard hardware uses a series of markings, and metric hardware uses a numeric system. Check the markings on the bolt heads and nuts for identification.

NOTICE

Improper operator handle usage. Use the manual operator handle on the transfer switch for maintenance purposes only. Return the transfer switch to the normal position. Remove the manual operator handle, if used, and store it in the place provided on the transfer switch when service is completed.

NOTICE

Foreign material contamination. Cover the transfer switch during installation to keep dirt, grit, metal drill chips, and other debris out of the components. Cover the solenoid mechanism during installation. After installation, use the manual operating handle to cycle the contactor to verify that it operates freely. Do not use a screwdriver to force the contactor mechanism.

NOTICE

Electrostatic discharge damage. Electrostatic discharge (ESD) damages electronic circuit boards. Prevent electrostatic discharge damage by wearing an approved grounding wrist strap when handling electronic circuit boards or integrated circuits. An approved grounding wrist strap provides a high resistance (about 1 megohm), *not a direct short*, to ground.

Notes

This manual provides service and parts information for Kohler® Model RDT and SE-ILC transfer switches with and without load centers. These models are equipped with MPAC™ 500 electrical controls and 100–400 ampere contactor power switching devices. See Figure 1.

The Model SE-ILC is a 200-amp, 240 VAC/60 Hz service entrance rated model with a 42-circuit load center and circuit breaker disconnects for the sources.

This manual covers troubleshooting, repair, maintenance, and service parts for the transfer switch including the power switching device and electrical controls. This manual is intended for use only by authorized personnel trained and qualified to work on electrical equipment.

Information in this publication represents data available at the time of print. Kohler Co. reserves the right to change this literature and the products represented without notice and without any obligation or liability whatsoever.

Read this manual and carefully follow all procedures and safety precautions to ensure proper equipment operation and to avoid bodily injury. Read and follow the Safety Precautions and Instructions section at the beginning of this manual. Keep this manual with the equipment for future reference.

The equipment service requirements are very important to safe and efficient operation. Inspect parts often and perform required service at the prescribed intervals. Obtain service from an authorized service distributor/dealer to keep equipment in top condition.



Figure 1 Model RDT ATS with Load Center

List of Related Materials

Refer to the Operation and Installation Manual for information on installation, operation, and routine maintenance. The following table lists the available literature part numbers.

Document	Part Number
Model RDT Operation and Installation Manual	TP-6345
Model RDT Specification Sheet	G11-98
Model RDT Mounting Template	G25-15
Model SE-ILC Operation and Installation Manual	TP-6378
Model SE-ILC Specification Sheet	G11-99

Service Assistance

For professional advice on generator power requirements and conscientious service, please contact your nearest Kohler distributor or dealer.

- Consult the Yellow Pages under the heading Generators—Electric
- Visit the Kohler Power Systems website at KohlerPowerSystems.com
- Look at the labels and stickers on your Kohler product or review the appropriate literature or documents included with the product
- Call toll free in the US and Canada 1-800-544-2444
- Outside the US and Canada, call the nearest regional office

Headquarters Europe, Middle East, Africa (EMEA)

Kohler Power Systems
ZI Senia 122
12, rue des Hauts Flouviars
94517 Thiais Cedex
France
Phone: (33) 1 41 735500
Fax: (33) 1 41 735501

Asia Pacific

Power Systems Asia Pacific Regional Office
Singapore, Republic of Singapore
Phone: (65) 6264-6422
Fax: (65) 6264-6455

China

North China Regional Office, Beijing
Phone: (86) 10 6518 7950
(86) 10 6518 7951
(86) 10 6518 7952
Fax: (86) 10 6518 7955

East China Regional Office, Shanghai
Phone: (86) 21 6288 0500
Fax: (86) 21 6288 0550

India, Bangladesh, Sri Lanka

India Regional Office
Bangalore, India
Phone: (91) 80 3366208
(91) 80 3366231
Fax: (91) 80 3315972

Japan, Korea

North Asia Regional Office
Tokyo, Japan
Phone: (813) 3440-4515
Fax: (813) 3440-2727

Latin America

Latin America Regional Office
Lakeland, Florida, USA
Phone: (863) 619-7568
Fax: (863) 701-7131

Section 1 Specifications and Service Views

1.1 Specifications

	Specifications
Operating temperature:	-20°C to 70°C (-4°F to 158°F)
Storage temperature:	-40°C to 85°C (-40°F to 185°F)
Humidity:	5 to 95% noncondensing

Figure 1-1 Environmental Specifications

Contact	Rating
Engine start	0.5 A @ 125 VAC; 2 A @ 30 VDC SPST normally closed (NC)
Common fault	0.5 A @ 125 VAC; 2 A @ 30 VDC SPST normally open (NO)
Load control	10 A @ 120 VAC SPST normally open (NO)
Auxiliary contacts (optional)	15 A @ 277 VAC Form C

Figure 1-2 Contact Ratings

AL/CU UL-Listed Solderless Screw-Type Terminals for External Power Connections		
Switch Size, Amps	Range of Wire Sizes, Cu/Al	
	Normal, Emergency, Load, and Neutral	Ground
100	(1) #12 to 1/0 AWG	(1) #14 to #4 AWG Cu
200	(1) #6 AWG to 250 MCM	(1) #14 to #4 AWG Cu
400	(2) #1/0 AWG to 250 MCM or (1) #4 AWG to 600 MCM	(1) #14 to 1/0 AWG

Figure 1-3 Cable Sizes

Enclosure Type	Amps	Load Center	Weight, kg (lb.)		Dimensions, H x W x D, mm (in.)	
NEMA 1	100	None	10.9	(24.0)	610 x 330 x 154 *	(24.0 x 13.0 x 6.0) *
	100	12 circuits	12.3	(27.0)	610 x 330 x 154 *	(24.0 x 13.0 x 6.0) *
	200	None	12.0	(26.3)	610 x 330 x 154 *	(24.0 x 13.0 x 6.0) *
	200	24 circuits	20.4	(45.0)	914 x 406 x 154	(36.0 x 16.0 x 6.0)
	400	None	52.0	(115)	1223 x 560 x 362	(48.1 x 22.0 x 14.3)
NEMA 3R	100	None	14.0	(30.7)	613 x 340 x 177	(24.1 x 13.4 x 7.0)
	100	12 circuits	15.3	(33.8)	613 x 340 x 177	(24.1 x 13.4 x 7.0)
	200	None	15.0	(33.0)	613 x 340 x 177	(24.1 x 13.4 x 7.0)
	200	24 circuits	25.9	(57.0)	917 x 416 x 177	(36.1 x 16.4 x 7.0)
	400	None	52.0	(115)	1223 x 560 x 416	(48.1 x 22.0 x 16.4)

* Can be recess-mounted between 16 in. O.C. wall studs.

Figure 1-4 Weights and Dimensions

Description	Terminals	Contact Rating	Wire Size	Tightening Torque	Max. Distance
Load Control	P2-1 and P2-2	10 A @ 120 VAC SPST normally open (NO)	#12-24 AWG	0.8 Nm (7 in. lbs.)	213 m (700 ft.)
Engine Start	P2-3 and P2-4	0.5 A @ 125 VAC; 2 A @ 30 VDC SPST normally closed (NC)	#12-24 AWG	0.8 Nm (7 in. lbs.)	213 m (700 ft.)
Common Fault	P2-5 and P2-6	0.5 A @ 125 VAC; 2 A @ 30 VDC SPST normally open (NO), latches closed	#12-24 AWG	0.8 Nm (7 in. lbs.)	213 m (700 ft.)

Figure 1-5 Controller Main Logic Board Customer Connections (P2)

1.2 Transfer Switch Components

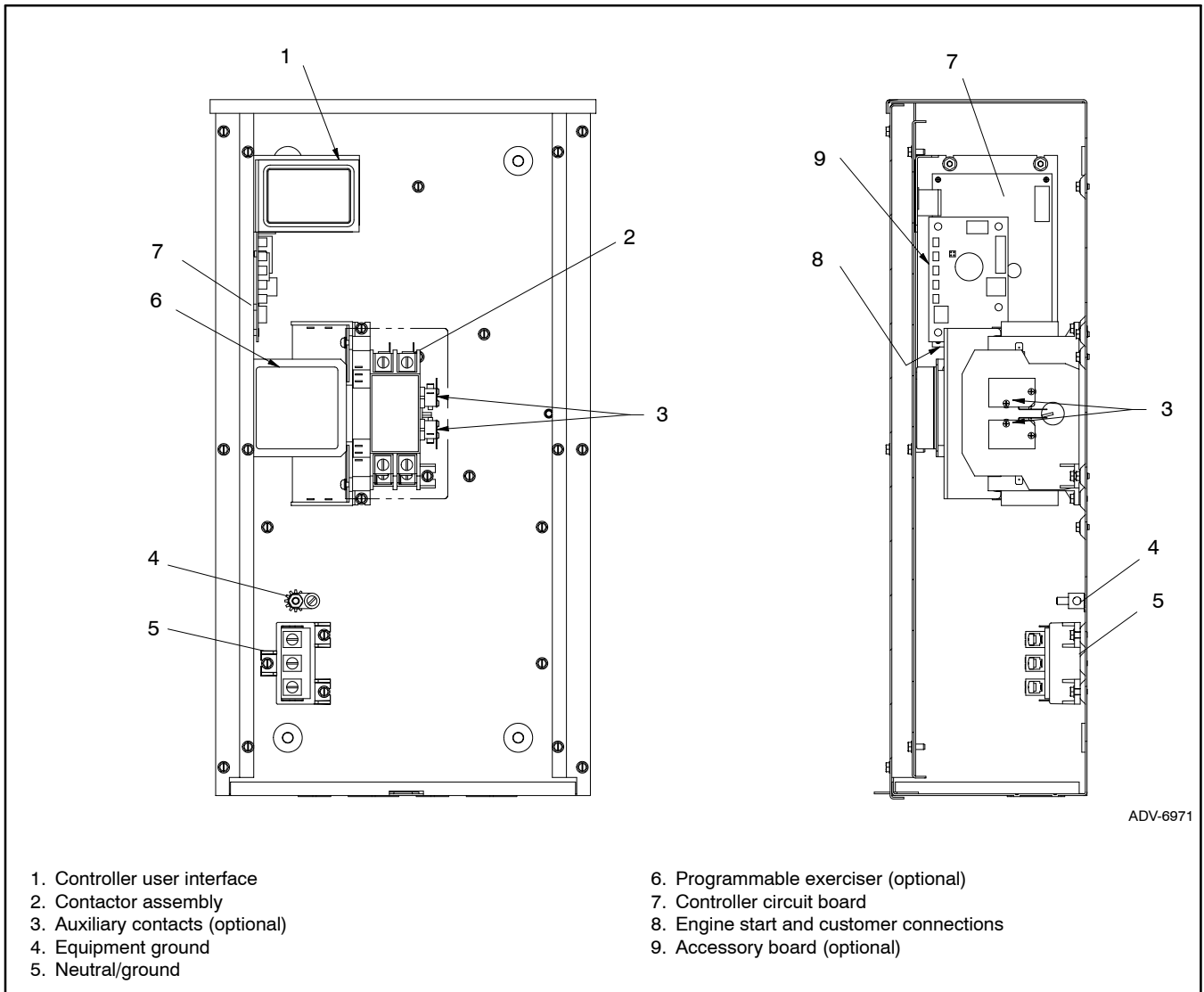

Figure 1-6 100 Amp Model without Load Center

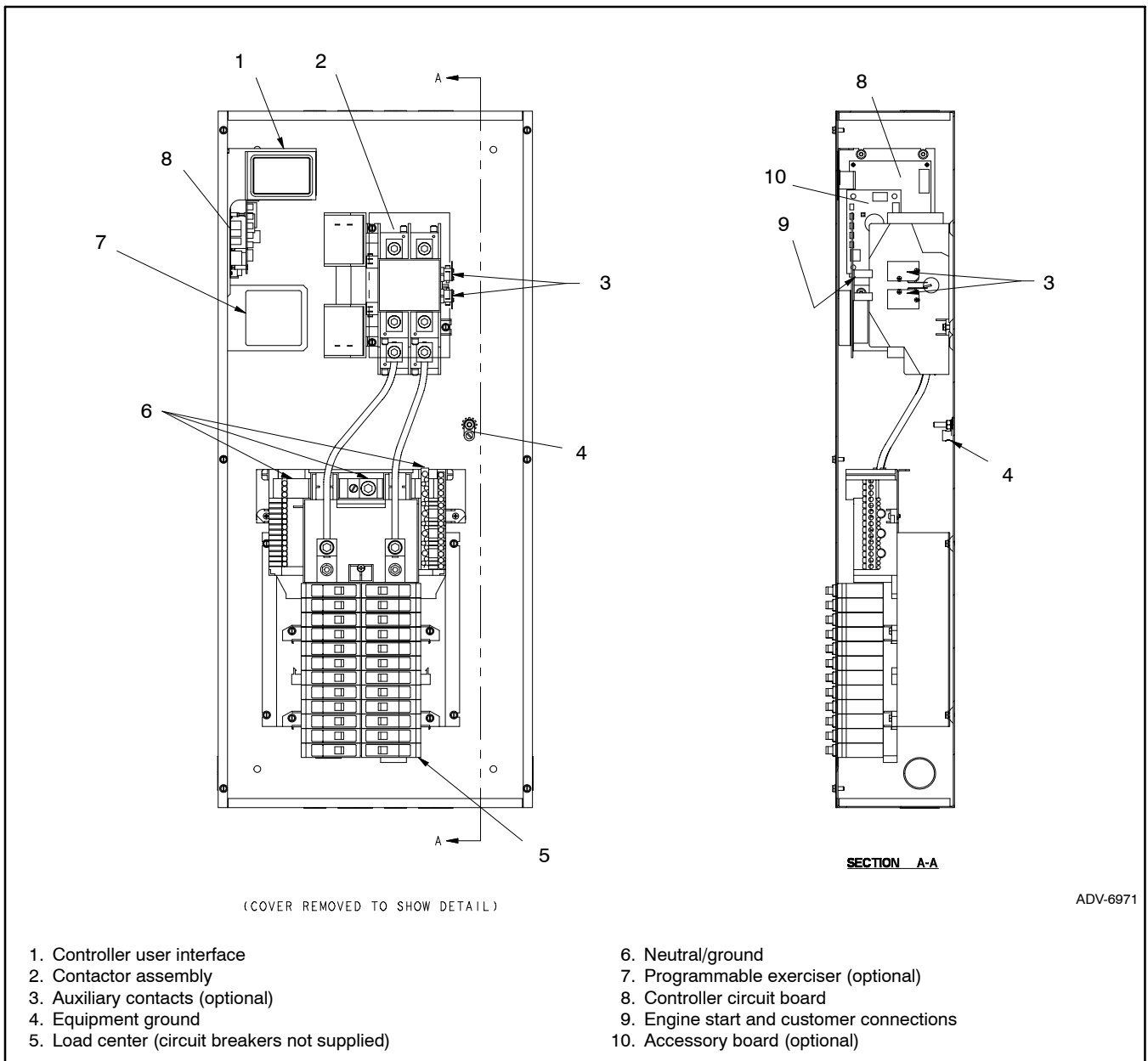
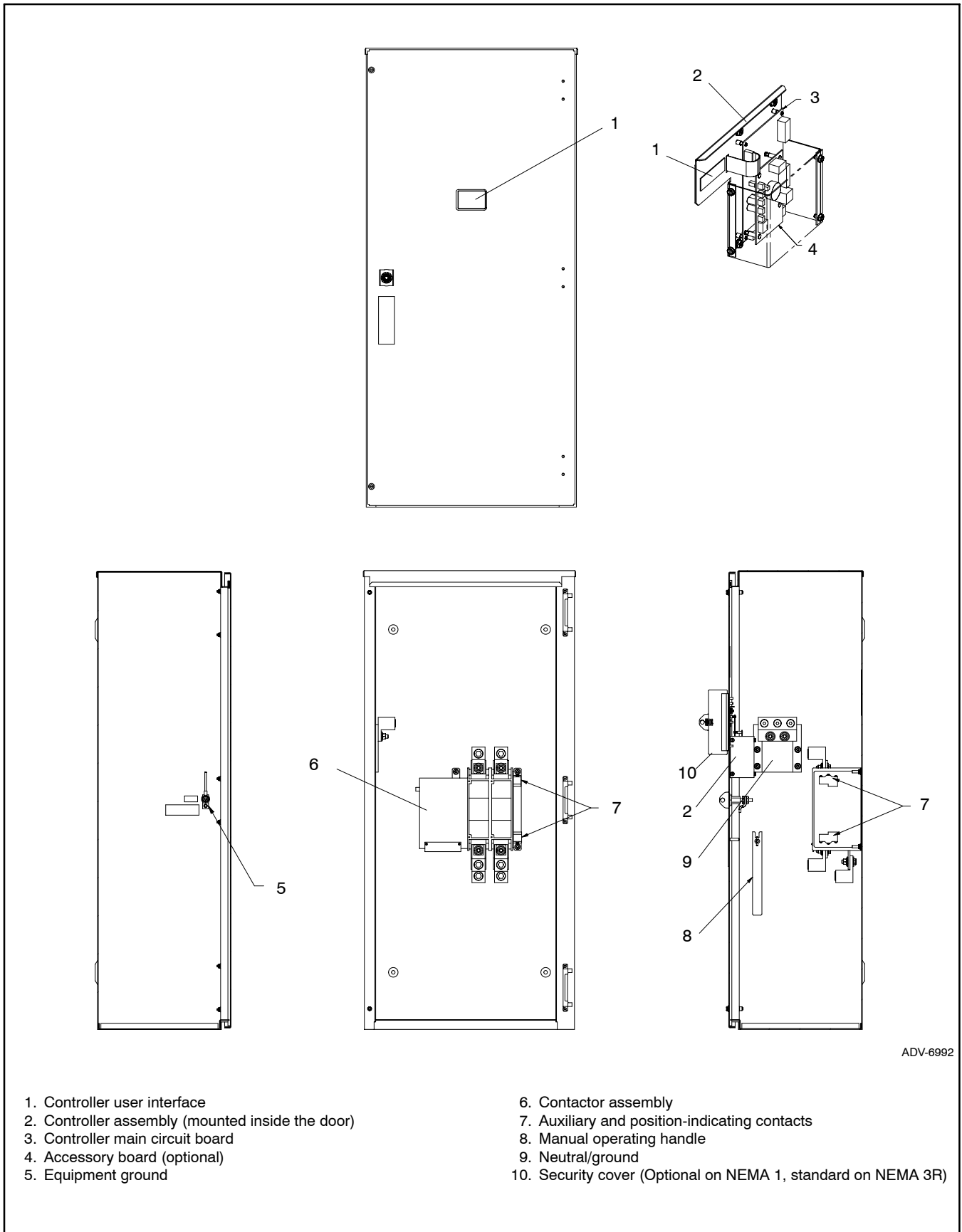

Figure 1-7 200 Amp with Load Center



ADV-6992

- | | |
|--------------------------------------------------------------------------------------------------------------------------------------------------------------------------------------------------------------------------------------------------------|---------------------------------------------------------------------------------------------------------------------------------------------------------------------------------------------------------------------------------------------------------------------|
| <ul style="list-style-type: none"> 1. Controller user interface 2. Controller assembly (mounted inside the door) 3. Controller main circuit board 4. Accessory board (optional) 5. Equipment ground | <ul style="list-style-type: none"> 6. Contactor assembly 7. Auxiliary and position-indicating contacts 8. Manual operating handle 9. Neutral/ground 10. Security cover (Optional on NEMA 1, standard on NEMA 3R) |
|--------------------------------------------------------------------------------------------------------------------------------------------------------------------------------------------------------------------------------------------------------|---------------------------------------------------------------------------------------------------------------------------------------------------------------------------------------------------------------------------------------------------------------------|

Figure 1-8 400 Amp Model

2.1 Introduction

Refer to TP-6345, Operation/Installation, for more information on transfer switch operation.

Red and green LEDs on the transfer switch controls indicate which sources are available, show which source is connected to the load, and flash to indicate fault conditions. Pushbuttons allow you to start and stop the generator set and set the exercise timer. See Figure 2-1.

The transfer switch uses fixed settings for time delays, voltage and frequency pickup and dropout, and other system settings. An optional Accessory Board allows changes to the time delays and exerciser settings and

provides connections for remote test and remote exercise inputs.

2.2 Controls

The controller's user interface panel is accessible through an opening in the transfer switch cover (the inner panel on NEMA type 3R enclosures). Figure 2-1 explains the operation of the controller pushbuttons and LED indicators.

The LEDs light steadily or flash to indicate different ATS conditions as shown in Figure 4-7. See Section 4.3 for more information on fault conditions.

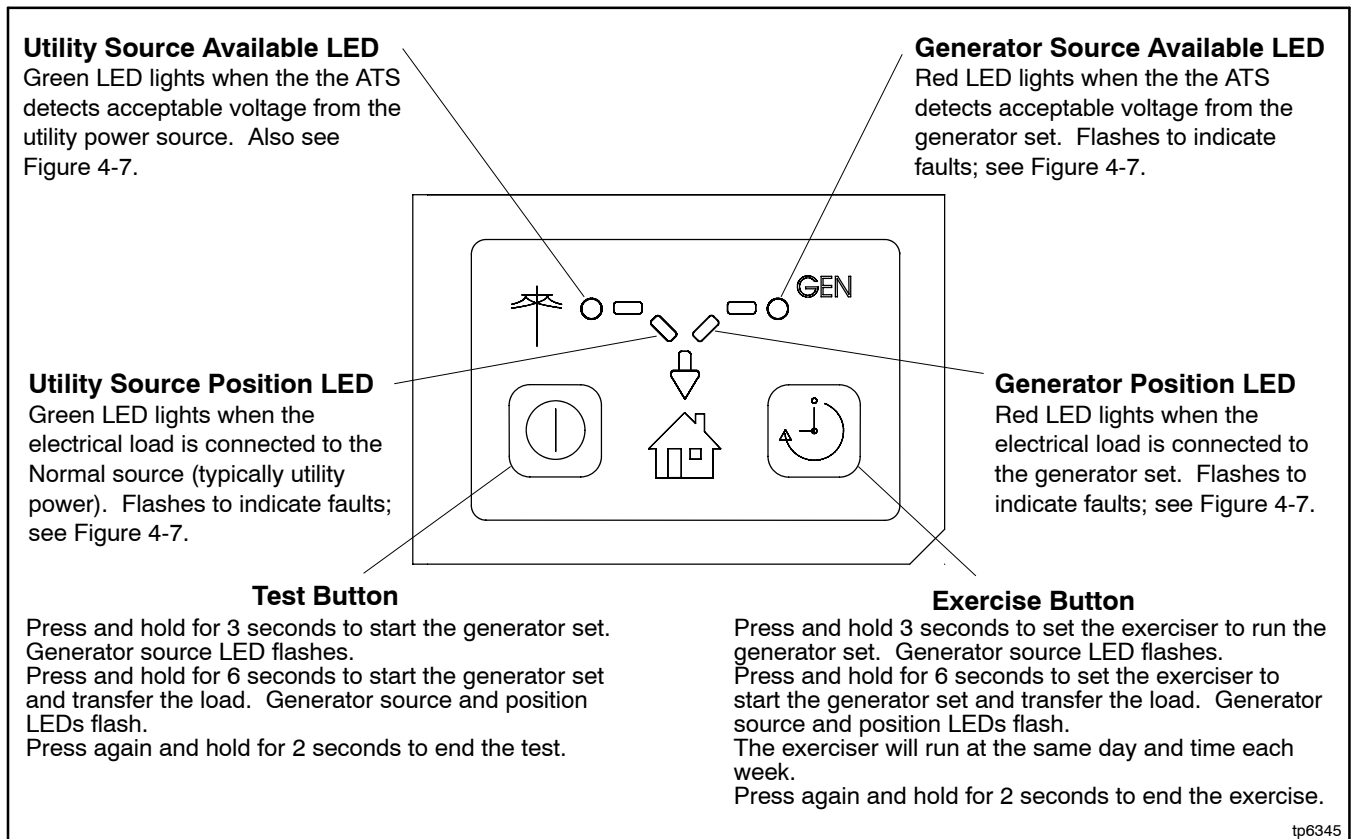

Figure 2-1 User Interface Panel

2.3 Test Sequence

Use the test procedure below to run the transfer switch test sequence. Loaded or unloaded test sequences can be run. The test sequence starts the generator set, and, for a loaded test, transfers the load to the emergency source. When the test ends, the transfer switch transfers the load back to the normal source and removes the engine start signal.

Note: The Test sequence bypasses the engine start and retransfer to Normal time delays. For instructions to simulate a loss of the Normal source and execute all applicable time delays, see Section 5.4.

Transfer switches equipped with the optional accessory board may use different time delays than the factory settings shown in the test procedure. See Figure 2-2 and Figure 2-3.

Refer to Section 2.5 for a description of the transfer switch sequence of operation.

Note: If the generator set fails during a test, the ATS will immediately attempt to transfer to the normal (utility) source.

Note: Install the front panel(s) or close and lock the enclosure door before starting the test procedure.

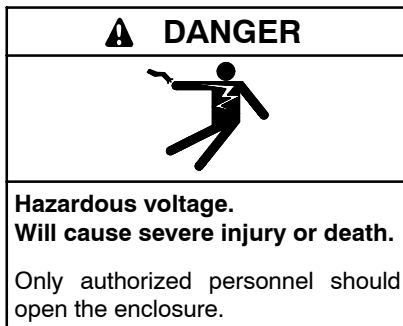

Procedure to Run the Test Sequence

1. Check the controller LED indicators to verify that the Utility Source Available and Utility Source Position indicators are lit. See Figure 2-1.
2. Verify that the generator set master switch is in the AUTO position.
3. Run a loaded or an unloaded test as described below:
 - a. **Loaded Test:** Press and hold the TEST button on the controller for 6 seconds to start a loaded test. The GEN Source and Position LEDs flash to indicate that the ATS controller is set up to transfer the load during the test.
 - b. **Unloaded Test:** To start the generator set without transferring the load, hold the TEST button for 3 to 5 seconds. The GEN Position LED flashes to indicate an unloaded test.

Time Delays			
Time Delay	Factory Setting	Adjustment with Accessory Board*	
		Range	Increment
Engine Start	3 sec.	1-10 sec.	1 sec.
Transfer from Normal to Emergency	3 sec.	1-10 sec.	1 sec.
Retransfer from Emergency to Normal	6 min.	3-30 min.	3 min.
Engine Cooldown	5 min.	1-10 min.	1 min.
Failure to Acquire Emergency	78 sec.†	NA	
Exercise Time Duration	20 min.	5-50 min.	5 min.
Undervoltage Dropout Time	0.5 sec.	NA	
Underfrequency Dropout Time	3 sec.	NA	

* Optional accessory board required for time delay adjustments. NA = not adjustable
 † Allows for three 15 sec. crank attempts separated by two 15 sec. rest periods.

Figure 2-2 Time Delays

Time Delay	Factory Setting		Adjustment with Optional Accessory Board	
	Setting	Switch Position (1-0)	Range	Increment
Engine Cooldown	5 minutes	5	1-10 minutes	1 minute
Engine Start	3 seconds	3	1-10 seconds	1 second
Transfer from Normal to Emergency	3 seconds	3	1-10 seconds	1 second
Retransfer from Emergency to Normal	6 minutes	2	3-30 minutes	3 minutes
Exercise Run Time	20 minutes	4	5-50 minutes	5 minutes

Figure 2-3 Accessory Board Time Delay Switch Settings

4. Verify that the generator set engine starts and the GEN Available LED flashes.
5. For a loaded test, the switch transfers the load to the emergency source (generator set) after the transfer to Emergency time delay. Verify that the Utility Source Position LED goes out and the GEN Position LED lights.
6. Press and hold the Test button for 2 seconds to end the test.
7. For a loaded test, the switch transfers the load to the normal (utility) source. Verify that the GEN Position LED goes out and the Utility Position LED lights.

Note: The retransfer time delay does not operate during the test sequence.

8. After the engine cooldown time delay, the generator set shuts down.

Note: The generator set may have an additional engine cooldown time delay that causes the engine to run after the transfer switch engine start signal is removed.

2.4 Exerciser Setup

2.4.1 Standard Exerciser

Follow the instructions below to set the exercise timer to automatically start and run the generator set for 20 minutes every week. The exerciser can be set for loaded or unloaded exercise runs. The factory settings for the exerciser are summarized in Figure 2-4.

Pressing and holding the Exercise button will start an exercise run and set the exercise timer as described below. The exercise time and day are set to the time that the Exercise button is pushed. The exerciser will run at the same time on the same day each week.

While the generator set is running during an exercise period, the exercise can be ended early by pressing and holding the exercise button for 2 seconds. Ending the current exercise period early does not affect future exercise runs.

Unloaded exercise. The generator set runs, but the electrical load is not transferred. Press and hold the Exercise button for approximately 3 seconds until the GEN Available LED flashes to start an unloaded exercise and set the time and date of the next exercise run. The GEN available LED continues to flash throughout the exercise run to indicate an unloaded exercise.

Loaded Exercise. The generator set runs and the ATS transfers the electrical load to the generator set. Hold the button for at least 6 seconds until the GEN available and GEN position LEDs flash to start a loaded exercise and set the time and date of the next exercise run. The GEN available and GEN position LEDs continue to flash throughout the exercise run to indicate a loaded exercise.

Resetting the Exerciser. After the exerciser has been set, pressing and holding the Exercise button to start an exercise run at a different time resets the exerciser to that new time and day.

Note: Resetting the controller by pressing and holding both the Exercise and Test buttons for at least 6 seconds clears the exercise setting.

Exerciser	
Parameter	Setting
Frequency *	Weekly
Duration *	20 minutes
Type	Loaded: Hold Exercise button for 3-5 seconds Unloaded: Hold Exercise button for 6+ seconds
* The optional Accessory Board allows adjustment of these parameters. The optional Programmer Exerciser allows setup of additional exercise runs of different duration.	

Figure 2-4 Exerciser Settings

2.4.2 Exerciser Options

The optional accessory board allows setting the exerciser for biweekly exercise runs and adjustment of the exercise run duration from 5 to 50 minutes. See the ATS Operation/Installation Manual.

The optional programmable exercise timer allows more flexibility in programming additional exercise periods of different duration. See the ATS Operation/Installation Manual.

2.5 Sequence of Operation

2.5.1 Source Sensing

The transfer switch controller monitors the utility power source voltage, and initiates the transfer sequence if the source voltage falls below the voltage dropout setting. Retransfer is initiated when the utility source rises above the voltage pickup settings and remains stable for at least 6 minutes. See Figure 2-5.

- Single-phase voltage sensing on both sources, $\pm 5\%$
- Line-to-line frequency sensing on emergency (GEN) source, $\pm 2\%$

Source Sensing	
Undervoltage dropout	80%
Undervoltage pickup	85%
Underfrequency dropout *	90%
Underfrequency pickup *	96%
* Emergency (GEN) source only	

Figure 2-5 Source Sensing

2.5.2 Powerup/Reset Sequence

Figure 2-6 shows the sequence when power is initially applied to the ATS controller or when the controller is reset.

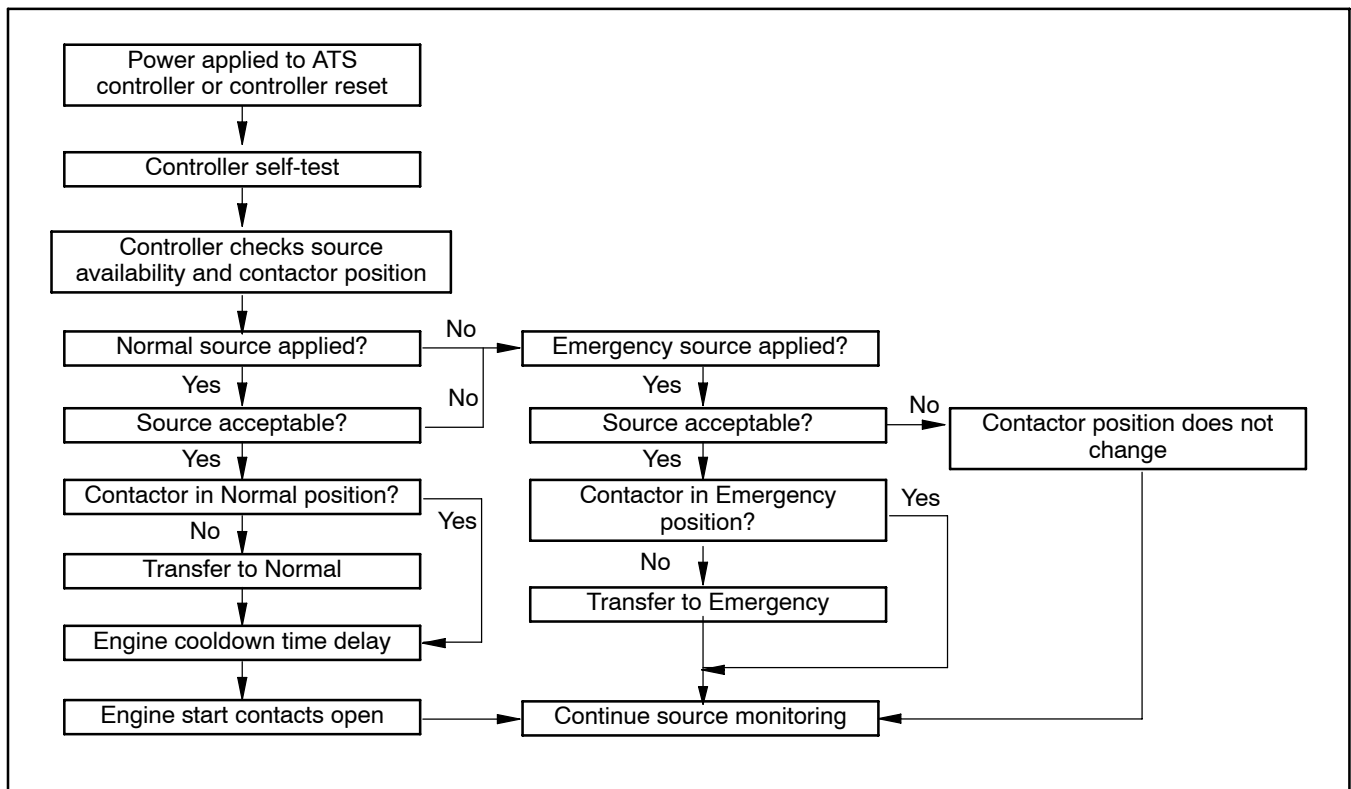

Figure 2-6 Powerup/Reset Sequence

2.5.3 Transfer Sequence

Figure 2-7 illustrates the transfer sequence when the normal (utility) source fails, and Figure 2-8 illustrates the sequence when normal power returns. Time delays before load transfer prevent nuisance transfers during brief power interruptions. See Figure 2-2. Events such as the failure of the generator set to start can change the sequence of operation.

If the emergency source fails and the normal source is not available, the transfer switch controller powers down until one of the sources returns.

The optional Accessory board allows time delay adjustments. See Figure 2-3.

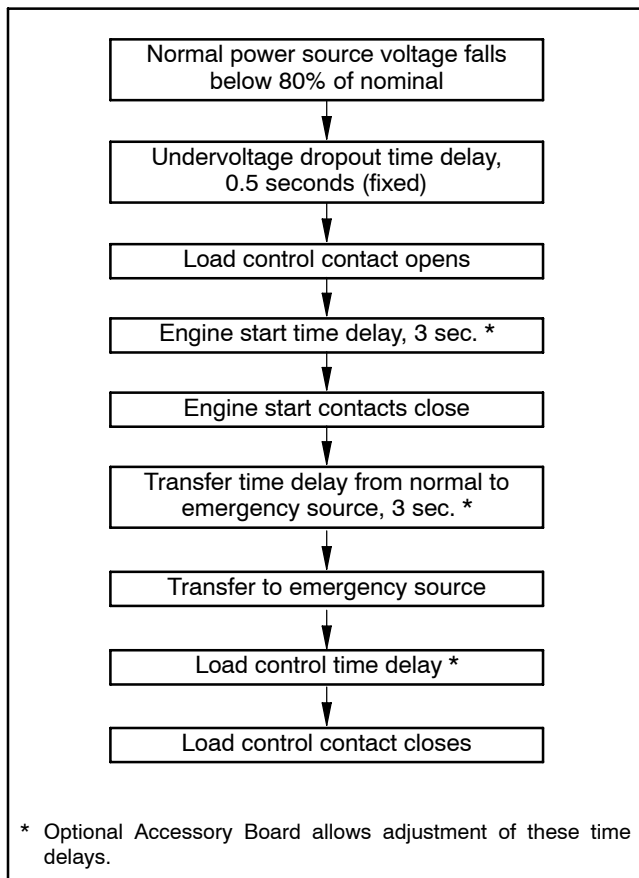

Figure 2-7 ATS Sequence of Operation, Transfer to Emergency

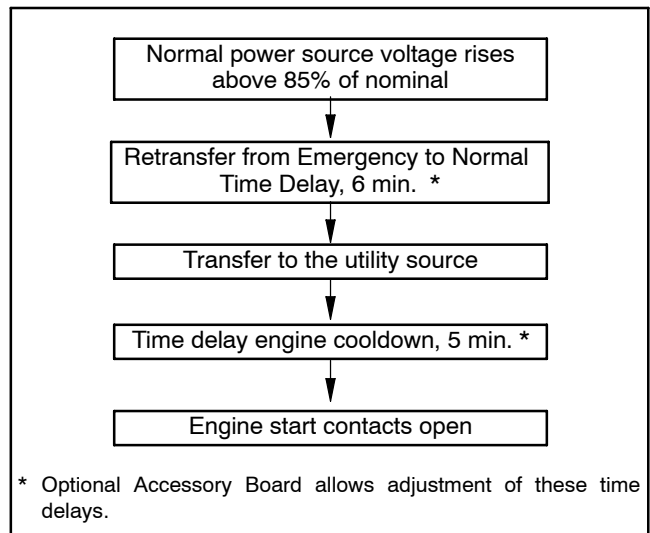

Figure 2-8 ATS Sequence of Operation, Retransfer to Normal

2.5.4 Test Sequence

See Figure 2-9 and Figure 2-10 for unloaded and loaded test sequences.

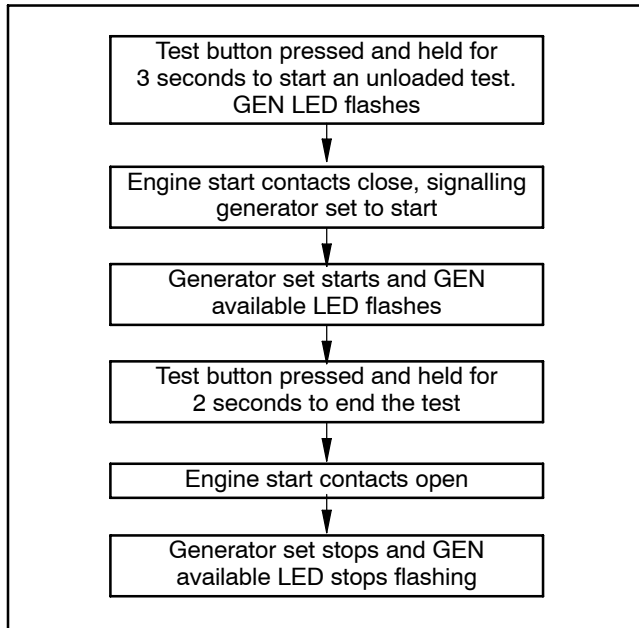

Figure 2-9 Unloaded Test Sequence

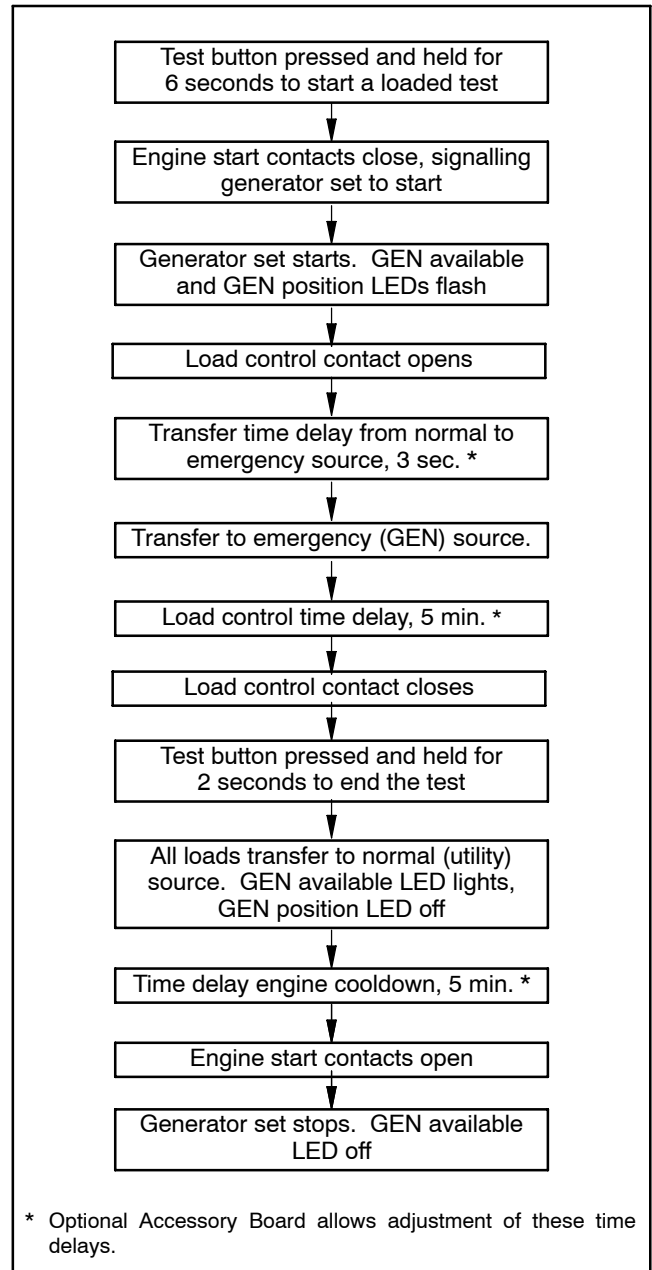

Figure 2-10 Loaded Test Sequence

2.5.5 Exercise Sequence

See Figure 2-11 and Figure 2-12 for unloaded and loaded exercise sequences.

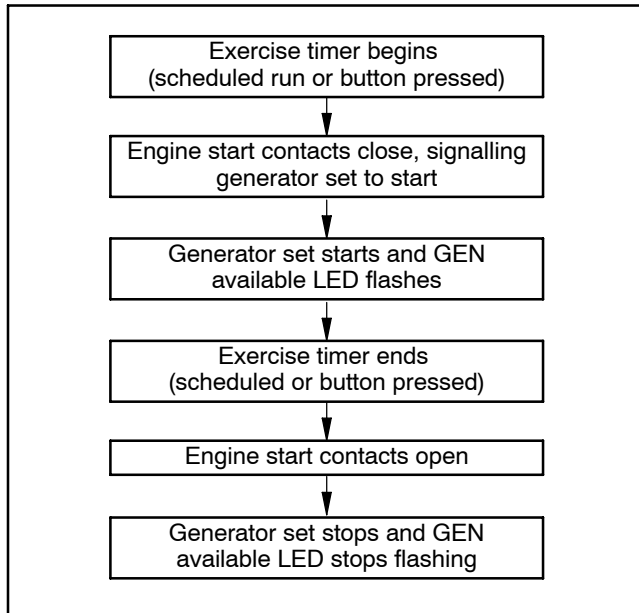

Figure 2-11 Unloaded Exercise Sequence

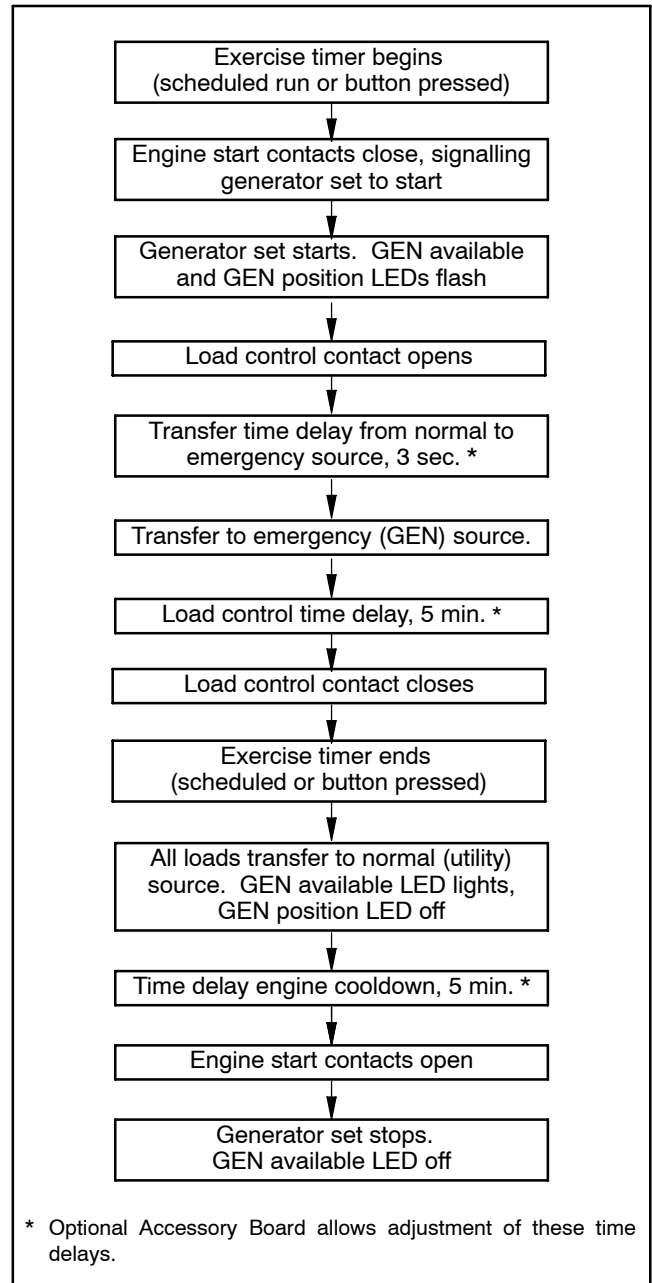
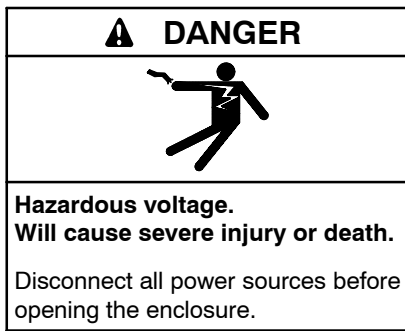

Figure 2-12 Loaded Exercise Sequence

2.6 Manual Operation



Note: Do not manually operate the transfer switch with power connected.

Check the manual operation before energizing the transfer switch. Verify that the contactor operates smoothly without binding.

Manual Operation, 100 and 200 Amp Switches

Note: Never manually operate the transfer switch when the power is connected. Disconnect both power sources before manually operating the switch.

1. Move the handle up to place the transfer switch in the Normal Source position and down to place the contactor in the Emergency Source position. See Figure 2-13.
2. Move the handle up to place the transfer switch in the Normal Source position for normal operation.

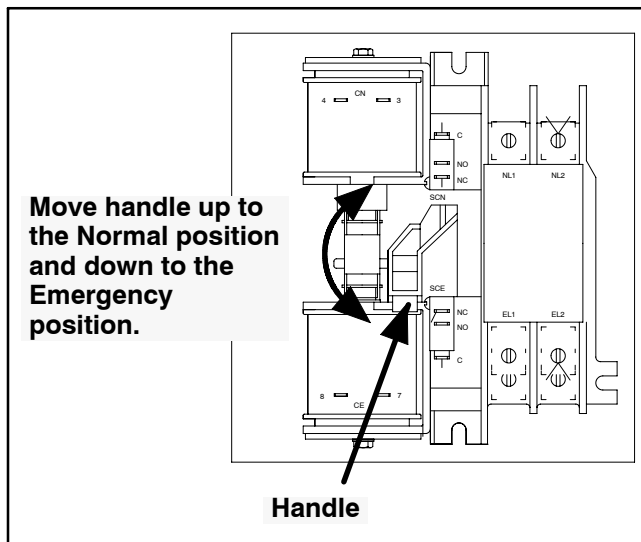
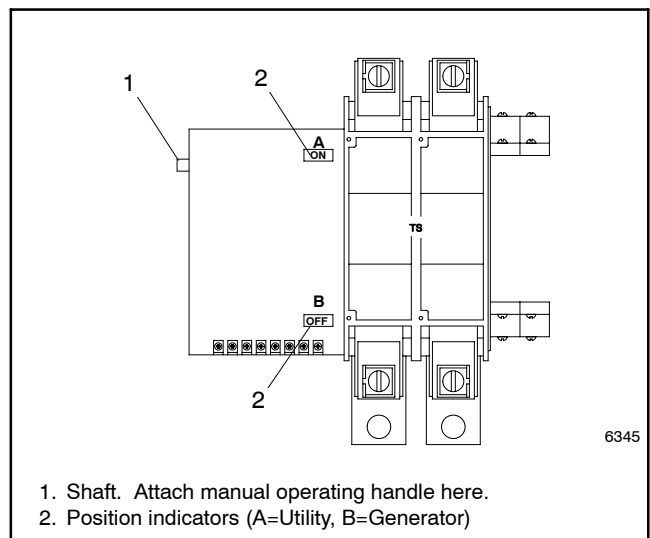

Figure 2-13 Manual Operation, 100 and 200 Amp Switches

Manual Operation, 400 Amp Switches

Note: Never manually operate the transfer switch when the power is connected. Disconnect both power sources before manually operating the switch.

1. Check the contactor position, indicated by the A and B position indicators. See Figure 2-14. One position indicator will display ON to indicate the source position. A is utility power and B is the generator set.
2. Slide the manual operating handle (provided with the switch) over the shaft on the left side of the switch. See Figure 2-14 and Figure 2-15.
3. Move the manual operation handle down and then release the handle. Verify that the desired source position indicator displays ON.
4. Place the transfer switch in position A (utility).
5. Remove the manual operation handle and store it in a convenient location.



1. Shaft. Attach manual operating handle here.
2. Position indicators (A=Utility, B=Generator)

Figure 2-14 400 Amp Contactor

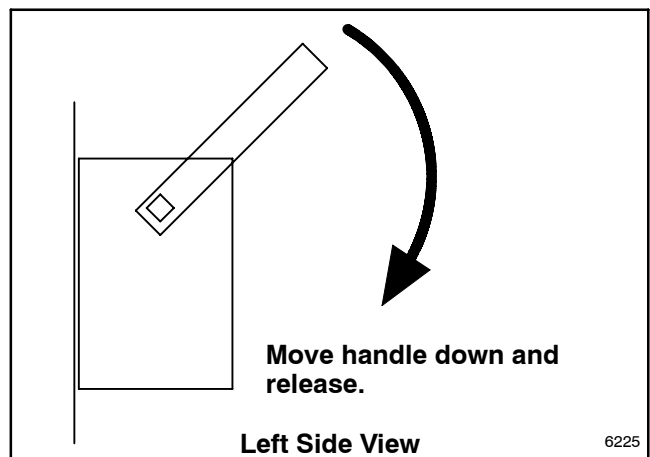

Figure 2-15 Manual Operation, 400 Amp

Section 3 Scheduled Maintenance

3.1 Introduction

Regular preventive maintenance ensures safe and reliable operation and extends the life of the transfer switch. Preventive maintenance includes periodic testing, cleaning, inspecting, and replacing of worn or missing components. Section 3.4 contains a service schedule of recommended maintenance tasks.

A local authorized distributor/dealer can provide complete preventive maintenance and service to keep the transfer switch in top condition. Unless otherwise specified, have maintenance or service performed by an authorized distributor/dealer in accordance with all applicable codes and standards.

Keep records of all maintenance or service.

Replace all barriers and close and lock the enclosure door after maintenance or service and before reapplying power.

⚠ WARNING

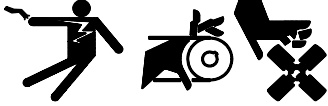

Accidental starting.
Can cause severe injury or death.

Disconnect the battery cables before working on the generator set. Remove the negative (-) lead first when disconnecting the battery. Reconnect the negative (-) lead last when reconnecting the battery.

Disabling the generator set. Accidental starting can cause severe injury or death. Before working on the generator set or connected equipment, disable the generator set as follows: (1) Move the generator set master switch to the OFF position. (2) Disconnect the power to the battery charger. (3) Remove the battery cables, negative (-) lead first. Reconnect the negative (-) lead last when reconnecting the battery. Follow these precautions to prevent starting of the generator set by an automatic transfer switch, remote start/stop switch, or engine start command from a remote computer.

⚠ WARNING



Hazardous voltage.
Can cause severe injury or death.

Disconnect all power sources before opening the enclosure.

(600 volts and under)

⚠ WARNING



Hazardous voltage.
Can cause severe injury or death.

Disconnect all power sources before servicing. Install the barrier after adjustments, maintenance, or servicing.

(600 volts and under)

⚠ WARNING

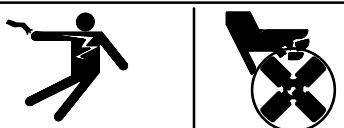

Hazardous voltage. Moving rotor.
Can cause severe injury or death.

Operate the generator set only when all guards and electrical enclosures are in place.

Grounding electrical equipment. Hazardous voltage can cause severe injury or death. Electrocution is possible whenever electricity is present. Open the main circuit breakers of all power sources before servicing the equipment. Configure the installation to electrically ground the generator set, transfer switch, and related equipment and electrical circuits to comply with applicable codes and standards. Never contact electrical leads or appliances when standing in water or on wet ground because these conditions increase the risk of electrocution.

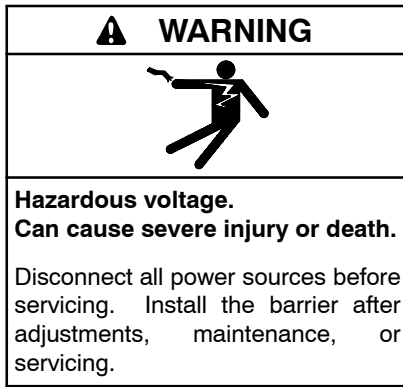

(600 volts and under)

Short circuits. Hazardous voltage/current can cause severe injury or death. Short circuits can cause bodily injury and/or equipment damage. Do not contact electrical connections with tools or jewelry while making adjustments or repairs. Remove all jewelry before servicing the equipment.

Testing live electrical circuits. Hazardous voltage or current can cause severe injury or death. Have trained and qualified personnel take diagnostic measurements of live circuits. Use adequately rated test equipment with electrically insulated probes and follow the instructions of the test equipment manufacturer when performing voltage tests. Observe the following precautions when performing voltage tests: (1) Remove all jewelry. (2) Stand on a dry, approved electrically insulated mat. (3) Do not touch the enclosure or components inside the enclosure. (4) Be prepared for the system to operate automatically.

(600 volts and under)

Servicing the transfer switch. Hazardous voltage can cause severe injury or death. Deenergize all power sources before servicing. Open the main circuit breakers of all transfer switch power sources and disable all generator sets as follows: (1) Move all generator set master controller switches to the OFF position. (2) Disconnect power to all battery chargers. (3) Disconnect all battery cables, negative (-) leads first. Reconnect negative (-) leads last when reconnecting the battery cables after servicing. Follow these precautions to prevent the starting of generator sets by an automatic transfer switch, remote start/stop switch, or engine start command from a remote computer. Before servicing any components inside the enclosure: (1) Remove all jewelry. (2) Stand on a dry, approved electrically insulated mat. (3) Test circuits with a voltmeter to verify that they are deenergized.

Servicing the transfer switch controls and accessories within the enclosure. Hazardous voltage can cause severe injury or death. Disconnect the transfer switch controls at the inline connector to deenergize the circuit boards and logic circuitry but allow the transfer switch to continue to supply power to the load. Disconnect all power sources to accessories that are mounted within the enclosure but are not wired through the controls and deenergized by inline connector separation. Test circuits with a voltmeter to verify that they are deenergized before servicing.

NOTICE

Hardware damage. The transfer switch may use both American Standard and metric hardware. Use the correct size tools to prevent rounding of the bolt heads and nuts.

NOTICE

When replacing hardware, do not substitute with inferior grade hardware. Screws and nuts are available in different hardness ratings. To indicate hardness, American Standard hardware uses a series of markings, and metric hardware uses a numeric system. Check the markings on the bolt heads and nuts for identification.

NOTICE

Electrostatic discharge damage. Electrostatic discharge (ESD) damages electronic circuit boards. Prevent electrostatic discharge damage by wearing an approved grounding wrist strap when handling electronic circuit boards or integrated circuits. An approved grounding wrist strap provides a high resistance (about 1 megohm), *not a direct short*, to ground.

3.2 Inspection and Service

3.2.1 General Inspection

External Inspection. Inspect the transfer switch weekly.

- Look for signs of vibration, leakage, excessive noise, high temperature, contamination, or deterioration.
- Remove accumulations of dirt, dust, and other contaminants from the transfer switch's exterior with a vacuum cleaner or by wiping with a dry cloth or brush. *Do not use compressed air to clean the switch because it can cause debris to lodge in the components and damage the switch.*
- Replace any worn, missing, or broken external components with manufacturer-recommended replacement parts. Contact a local authorized distributor/dealer for part information and ordering.
- Tighten loose external hardware.

Contact an authorized distributor/dealer to inspect and service the transfer switch when any wear, damage, deterioration, or malfunction of the transfer switch or its components is evident or suspected.

3.2.2 Internal Inspections and Maintenance

Internal Inspection. Have an authorized distributor/dealer perform an annual inspection of the transfer switch. Inspect the switch more frequently if it is located in a dusty or dirty area or when any condition noticed during an external inspection may have affected internal components. Disconnect all power sources, open the transfer switch enclosure, and inspect internal components. Look for:

- Accumulations of dirt, dust, moisture, or other contaminants
- Signs of corrosion
- Worn, missing, or broken components
- Loose hardware
- Wire or cable insulation deterioration, cuts, or abrasions
- Signs of overheating or loose connections: discoloration of metal, melted plastic, or a burning odor
- Other evidence of wear, damage, deterioration, or malfunction of the transfer switch or its components

Cleaning. Use a vacuum cleaner or a dry cloth or brush to remove contaminants from internal components. *Do not use compressed air to clean the switch because it can cause debris to lodge in the components and damage the switch.*

Periodically oil the enclosure door locks and screws.

Part Replacement and Tightening. Replace worn, missing, broken, deteriorated, or corroded internal components with manufacturer-recommended replacement parts. Contact a local authorized distributor/dealer for part information and part ordering. Tighten loose internal hardware.

Terminal Tightening. Loose connections on the power circuits can lead to overheating or explosion. Tighten all lugs to the torque values shown on the label on the switch. Tighten engine start, input/output, and auxiliary connections to the torque indicated on the decals affixed to the unit. See Figure 3-1 and Figure 3-2 for general torque specifications for lugs and screw terminals.

Signs of Overheating. Replace components damaged by overheating and locate the cause of the overheating. Overheating could be caused by loose power connections, overloading, or a short circuit in system. After tightening the power terminals, perform a millivolt drop test to locate areas with high contact resistance. See Section 3.3.3. Check the line circuit breakers in the system to be sure that they do not allow the load to exceed the switch rating. Use the controller troubleshooting and schematics to locate a control circuit short.

Wire Repair or Replacement. Replace wiring when there is any doubt about its condition or when there is extensive damage or deterioration. If the damaged or deteriorated wires are part of a wiring harness, replace the entire wiring harness.

Repair minor damage to leads in low power and control circuits operating up to 250 volts. Use UL-listed insulated (250 V minimum) connectors and follow the connector manufacturer's instructions. Fabricate new leads using the same type of wire and UL-listed insulated (250 V minimum) connectors and follow the connector manufacturer's instructions.

Power Circuit Wiring. Have damage to line voltage and power circuit wiring evaluated and repaired or replaced by a qualified electrician.

Wire Size (AWG or MCM)	Torque		
	in. lb.	ft. lb.	Nm
8	75	6.2	8.5
6	110	9.2	12
4	110	9.2	12
2	150	13	17
1	150	13	17
1/0	180	15	20
2/0	180	15	20
3/0	250	21	28
4/0	250	21	28
250	325	27	37

Figure 3-1 Tightening Torque for Terminal Lugs

Wire Size (AWG or MCM)	Torque		
	in. lb.	ft. lb.	Nm
14	35	2.9	4.0
12	35	2.9	4.0
10	35	2.9	4.0
8	40	3.3	4.5
6	45	3.8	5.1
4	45	3.8	5.1

Figure 3-2 Tightening Torque for Screw Terminals

Transfer Switch Inspection. Remove the arc chute assemblies or covers at the front of the transfer switch and inspect the main contacts inside the transfer switch. See Figure 3-3 and Figure 3-4.

Remove surface deposits with a clean cloth. *Do not use an emery cloth or a file.* Discoloration of the contact surface does not affect performance. If the contacts are pitted, show signs of overheating, or are worn, replace the contacts. The contacts are worn if the contact surface material, a layer of silvery-colored metal, is worn through to the metal below. Check the condition of the arc chutes. If arc chutes show signs of disintegration, replace the arc chute assembly.

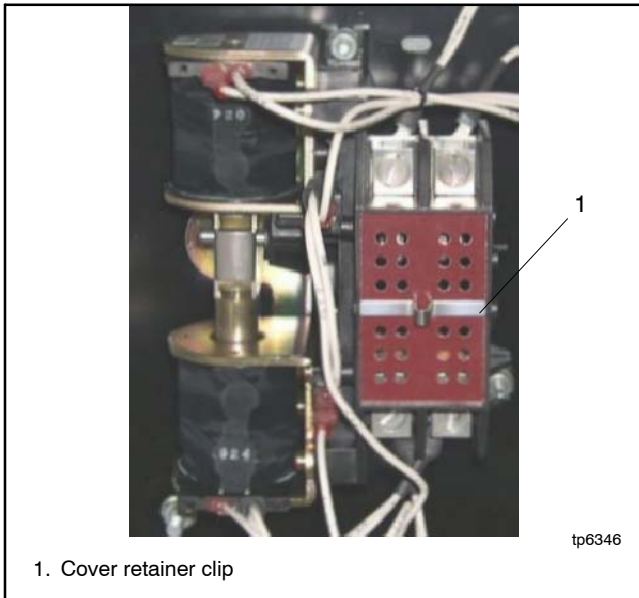

Figure 3-3 Typical Arc Chute Cover, 100/200 Amp Models

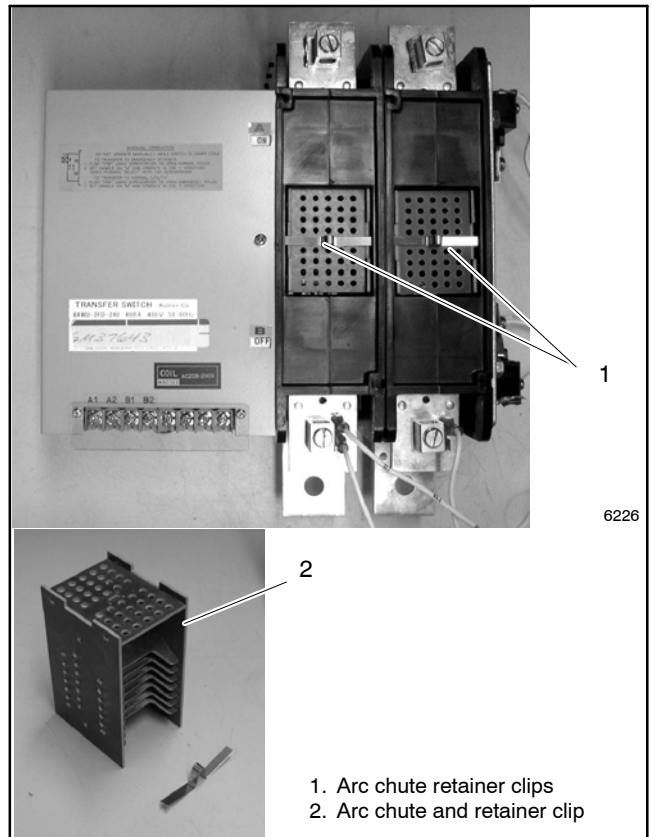

Figure 3-4 Typical Arc Chute Assemblies, 400-Amp Models

3.3 Testing

Periodic testing is important in any transfer switch application. It helps to ensure that the generator set will start and the transfer switch mechanisms and control circuits will operate when needed.

3.3.1 Weekly Generator Set Exercise

Use the plant exerciser to start and run the generator set once a week to maximize the reliability of the emergency power system. See the transfer switch operation and installation manual for additional information about the exerciser.

3.3.2 Monthly Automatic Operation Test

Test the transfer switch's automatic control system monthly. See Section 2.3 or the transfer switch operation and installation manual for the test procedure. Verify that the expected sequence of operations occurs as the switch transfers the load to the emergency source when a normal source failure occurs or is simulated. After the switch transfers the load to the emergency source, end the test and verify that the expected sequence of operations occurs as the transfer switch retransfers to the available normal source and signals the generator set to shut down after a cooldown period.

3.3.3 Other Tests

Every Year

Measure the voltage drop to help locate high-resistance contacts in the ATS. The test procedure measures the voltage drop across a contact and the current in the circuit, then uses those measured values to find the contact resistance.

The purpose of the test is to locate any contact that has significantly higher resistance than others. An unusually high voltage across one set of contacts may signal unacceptably high resistance in the contacts.

Run the test with the ATS under a moderate and balanced load. Use the following procedure to take voltage measurements and calculate resistances for both Source N and Source E.

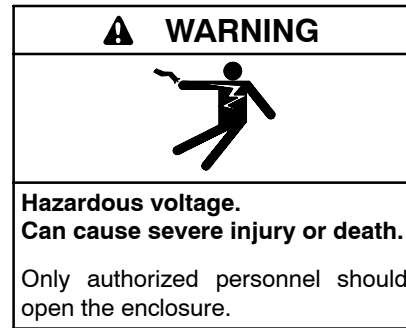

(600 volts and under)

Testing live electrical circuits. Hazardous voltage or current can cause severe injury or death. Have trained and qualified personnel take diagnostic measurements of live circuits. Use adequately rated test equipment with electrically insulated probes and follow the instructions of the test equipment manufacturer when performing voltage tests. Observe the following precautions when performing voltage tests: (1) Remove all jewelry. (2) Stand on a dry, approved electrically insulated mat. (3) Do not touch the enclosure or components inside the enclosure. (4) Be prepared for the system to operate automatically.

(600 volts and under)

Millivolt Drop Test Procedure

1. Apply a balanced load of at least 10% of the switch rating. (Currents of 10 amps or greater will give more accurate results than lower currents.)
2. Carefully measure the voltage on both sources from the source lug to the load lug. Take several readings to ensure accuracy. The readings may be erratic because of the small voltage measured, load fluctuations, and meter circuit contact resistances.

Note: To obtain accurate readings, keep the meter as far as possible from current-carrying conductors and the meter leads as short, direct, and at right angles to current-carrying conductors as possible. This minimizes the effect of induced voltages (transformer effect) in the vicinity of the current-carrying conductors.

3. Use an ammeter to measure the current flow through the circuit.

4. Calculate the contact resistance using the following formula:

$$R = V \div I$$

Where:

- V = measured voltage in *millivolts*
- I = measured current in *amps*
- R = calculated resistance in *milliohms*

Compare the calculated values for resistance (R) to the values in the table in Figure 3-5. If the calculated resistance is significantly higher (2 times larger or more) than the value shown in the table, disconnect power, check the connections and lug torques, and repeat the test. If the second measurement also indicates that the resistance is too high, replace the contactor.

Transfer Switch Rating, Amps	Maximum Contact Resistance, Milliohms (mΩ)
100-200	0.250
400	0.200

Figure 3-5 Maximum Contact Resistance

Every Three Years

Test the wire insulation. Use the following procedure to check for insulation breakdown and replace any faulty components.

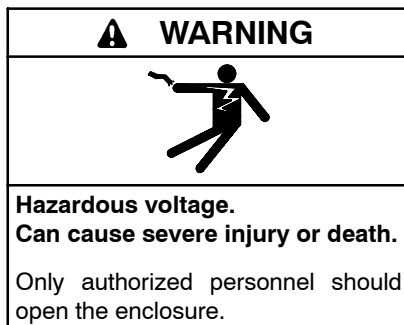

(600 volts and under)

Testing live electrical circuits. Hazardous voltage or current can cause severe injury or death. Have trained and qualified personnel take diagnostic measurements of live circuits. Use adequately rated test equipment with electrically insulated probes and follow the instructions of the test equipment manufacturer when performing voltage tests. Observe the following precautions when performing voltage tests: (1) Remove all jewelry. (2) Stand on a dry, approved electrically insulated mat. (3) Do not touch the enclosure or components inside the enclosure. (4) Be prepared for the system to operate automatically.

(600 volts and under)

Wire Insulation Breakdown Test Procedure

1. Disconnect all power sources by opening upstream circuit breakers or switches to the transfer switch. Disconnect the load from the transfer switch by opening circuit breakers or switches leading from the transfer switch. Disconnect the transfer switch wiring harness from the controller at connector P1.
2. Use a hi-pot tester or meggar to check the insulation resistance phase-to-phase and phase-to-neutral, and phase-to-ground if neutral and ground are isolated. For a hi-pot tester, the maximum potential is 500 VAC and the maximum test time is 1 second.
3. Verify that the measured insulation resistance exceeds 1.24 megohms (MΩ).
4. If the hi-pot tester indicates wire insulation breakdown or if the measured resistance is less than 1.24 MΩ, isolate the leakage current using an instrument designed for this purpose. Replace the faulty components.

Note: You may need to disconnect power conductors from the lugs to isolate the problem. If you disconnect the power conductors, see transfer switch operation and installation manual for reconnection instructions.

3.4 Service Schedule

Follow the service schedule in Figure 3-6 for the recommended service intervals. The transfer switch

operator can perform tasks marked by an X. Have an authorized distributor/dealer inspect the switch annually and perform all service marked by a D.

System Component or Procedure	See Section	Visually Inspect	Check	Adjust, Repair, or Replace	Clean	Test	Interval
Electrical System							
Check for signs of overheating or loose connections: discoloration of metal, melted plastic, or a burning odor.	3.2.2	X	X				Y
Check the transfer switch's external operating mechanism for cleanliness. Clean as needed.*	3.2.2	X			D		Y
Check wiring insulation for deterioration, cuts, or abrasion. Repair or replace wiring to regain the properties of the original wiring.	3.2.2	X					Y
		D	D	D			Y
Check the transfer switch's main power switching mechanisms' mechanical operation and integrity.	3.2.2	D	D			D	Y
Tighten control and power wiring connections to specifications.	3.2.2		D	D			Y
Check the transfer switch's main power switching contacts' condition. Clean or replace the main contacts or replace the transfer switch assembly as necessary.	3.2.2	D		D	D		Y
Perform a millivolt drop test to check for high contact resistances on power circuits. Tighten connections, clean main contacts, or adjust or replace main contacts or transfer switch assembly to eliminate high contact resistances.	3.3.3		D	D	D	D	Y
Test wire and cable insulation for electrical breakdown.	3.3.3					D	Every 3 Years
Control System							
Test the transfer switch's automatic control system.	O/I/M	X				X	M
Test all LED indicators, time delays, and remote control systems for operation.	O/I/M	D	D	D		D	Y
General Equipment Condition							
Inspect the outside of the transfer switch for any signs of excessive vibration, high temperature, contamination, or deterioration.*	3.2.1	X			X		M
Check that all external hardware is in place, tightened, and not badly worn.	3.2.1	X	X	X			M
Inspect the inside of the transfer switch for any signs of vibration, excessive noise, high temperature, contamination, or deterioration. Check for metal discoloration, melted plastic, or a burning odor.*	3.2.2	X					M
		D	D		D		Y
Check that all internal hardware is in place, tightened, and not badly worn.	3.2.2	X					M
		D	D	D			Y
* Service more frequently if the ATS operates in extremely dusty or dirty areas.							
See Section: Read these sections carefully for additional information before attempting maintenance or service.							
Visually Inspect: Examine these items visually.							
Check: Requires physical contact with or movement of system components, or the use of nonvisual indications.							
Adjust, Repair, or Replace: Includes tightening hardware. May require replacement of components depending upon the severity of the problem.							
Clean: Remove accumulations of dirt and contaminants from external transfer switch's components or enclosure with a vacuum cleaner or by wiping with a dry cloth or brush. <i>Do not use compressed air to clean the switch because it can cause debris to lodge in the components and cause damage.</i>							
Test: May require tools, equipment, or training available only through an authorized distributor/dealer.							
Symbols used in the chart:							
O/I/M=See the transfer switch operation/installation manual.				M=Monthly			
X=The transfer switch operator can perform these tasks.				Q=Quarterly			
D=An authorized distributor/dealer must perform these tasks.				S=Semiannually (every six months)			
W=Weekly				Y=Yearly (annually)			

Figure 3-6 Service Schedule

Notes

Section 4 Troubleshooting

This section contains transfer switch and controller troubleshooting information.

Note: Only trained qualified personnel following all applicable codes and standards should attempt to service the transfer switch.

Refer first to the troubleshooting chart in Figure 4-1. Possible causes of problems are listed generally in the order of likelihood. See the schematic and interconnection diagrams in Section 6, the parts drawings in Section 8, and the labeling on system components to identify and troubleshoot system components.

Observe all safety precautions while troubleshooting and servicing the transfer switch.

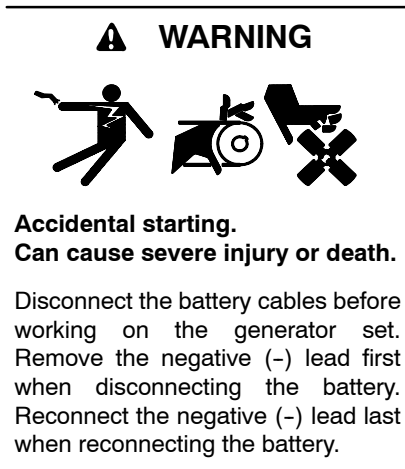

Disabling the generator set. Accidental starting can cause severe injury or death. Before working on the generator set or connected equipment, disable the generator set as follows: (1) Move the generator set master switch to the OFF position. (2) Disconnect the power to the battery charger. (3) Remove the battery cables, negative (-) lead first. Reconnect the negative (-) lead last when reconnecting the battery. Follow these precautions to prevent starting of the generator set by an automatic transfer switch, remote start/stop switch, or engine start command from a remote computer.

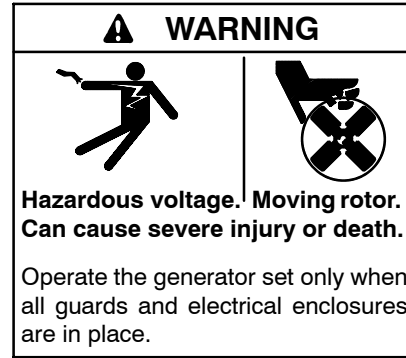

Grounding electrical equipment. Hazardous voltage can cause severe injury or death. Electrocutation is possible whenever electricity is present. Open the main circuit breakers of all power sources before servicing the equipment. Configure the installation to electrically ground the generator set, transfer switch, and related equipment and electrical circuits to comply with applicable codes and standards. Never contact electrical leads or appliances when standing in water or on wet ground because these conditions increase the risk of electrocution.

Connecting the battery and the battery charger. Hazardous voltage can cause severe injury or death. Reconnect the battery correctly, positive to positive and negative to negative, to avoid electrical shock and damage to the battery charger and battery(ies). Have a qualified electrician install the battery(ies).

Servicing the transfer switch. Hazardous voltage can cause severe injury or death. Deenergize all power sources before servicing. Open the main circuit breakers of all transfer switch power sources and disable all generator sets as follows: (1) Move all generator set master controller switches to the OFF position. (2) Disconnect power to all battery chargers. (3) Disconnect all battery cables, negative (-) leads first. Reconnect negative (-) leads last when reconnecting the battery cables after servicing. Follow these precautions to prevent the starting of generator sets by an automatic transfer switch, remote start/stop switch, or engine start command from a remote computer. Before servicing any components inside the enclosure: (1) Remove all jewelry. (2) Stand on a dry, approved electrically insulated mat. (3) Test circuits with a voltmeter to verify that they are deenergized.

Servicing the transfer switch controls and accessories within the enclosure. Hazardous voltage can cause severe injury or death. Disconnect the transfer switch controls at the inline connector to deenergize the circuit boards and logic circuitry but allow the transfer switch to continue to supply power to the load. Disconnect all power sources to accessories that are mounted within the enclosure but are not wired through the controls and deenergized by inline connector separation. Test circuits with a voltmeter to verify that they are deenergized before servicing.

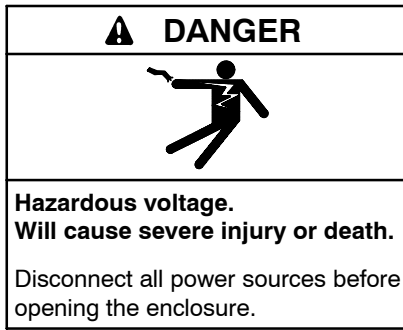

Short circuits. Hazardous voltage/current can cause severe injury or death. Short circuits can cause bodily injury and/or equipment damage. Do not contact electrical connections with tools or jewelry while making adjustments or repairs. Remove all jewelry before servicing the equipment.

Testing live electrical circuits. Hazardous voltage or current can cause severe injury or death. Have trained and qualified personnel take diagnostic measurements of live circuits. Use adequately rated test equipment with electrically insulated probes and follow the instructions of the test equipment manufacturer when performing voltage tests. Observe the following precautions when performing voltage tests: (1) Remove all jewelry. (2) Stand on a dry, approved electrically insulated mat. (3) Do not touch the enclosure or components inside the enclosure. (4) Be prepared for the system to operate automatically.
(600 volts and under)

NOTICE

Electrostatic discharge damage. Electrostatic discharge (ESD) damages electronic circuit boards. Prevent electrostatic discharge damage by wearing an approved grounding wrist strap when handling electronic circuit boards or integrated circuits. An approved grounding wrist strap provides a high resistance (about 1 megohm), *not a direct short*, to ground.

4.1 Initial Troubleshooting

Many service problems are caused by faulty connections due to corrosion, loose terminals, and damaged wiring or connectors. With all power supplies disconnected, perform the following general checks while troubleshooting.

- Unplug connectors and check terminals and leads for corrosion. Remove corrosion from terminals and leads.
- Tighten loose terminals.
- Check wiring harnesses for continuity or short circuits.
- Recrimp or replace loosely connected lead terminals.

Also check the following:

- Verify that the source circuit breakers/switches to the transfer switch are closed and at least one power source is available.
- Check that the generator set master switch is in the AUTO position and that the engine starting battery is connected and charged.
- Check the engine start circuit for loose or open connections or short circuits.
- Disconnect optional equipment such as the accessory board or programmable exerciser and test the ATS operation to isolate problems to the transfer switch or connected accessories.
- Connect a personal computer (PC) to the ATS controller as described in Section 5.5 and use the HyperTerminal program on your PC to check the ATS status and settings.

4.2 Troubleshooting Charts

Use the following troubleshooting charts to diagnose transfer switch problems.

Troubleshooting Chart		
Problem	Possible Cause	Corrective Action
ATS fails to operate and no LEDs are lit	No power to the transfer switch/controller.	Close circuit breakers leading from power sources to the transfer switch. Troubleshoot power to the system. See Section 5.1.
Generator set does not start when the normal source fails (Also see Figure 4-2)	Generator set master switch is in the OFF position or the batteries are not charged or connected.	Place the generator set master switch in the AUTO position. Check that the generator set batteries are charged and connected.
	Engine start circuit is malfunctioning.	Troubleshoot. See Section 5.8.
	Generator set is malfunctioning.	See the generator set operation or service manual.
Generator set does not start with the exerciser (Also see Figure 4-2 and Figure 4-4)	Generator set master switch is in the OFF position or the batteries are not charged or connected.	Place the generator set master switch in the AUTO position. Check that the generator set batteries are charged and connected.
	Engine start circuit is malfunctioning.	See Section 5.8 to troubleshoot the engine start circuit.
	Generator set is malfunctioning.	See the generator set operation or service manual.
Generator set does not shut down (Also see Figure 4-6)	Generator set master switch is in the RUN position.	Place the generator set master switch in the AUTO position.
	The engine start circuit is malfunctioning, or the exerciser is operating.	If the exerciser has recently been in the Set position or is in the Enable position, wait for the exerciser period of 20 minutes to end. If the generator set continues to run, see Section 5.8 to troubleshoot the engine start circuit.
	Time delay engine cooldown (TDEC) has not timed out. (after retransferring the load to the normal source)	Check operation. Enough time must pass for the engine cooldown time delay to expire.
	Generator set is malfunctioning.	See the generator set operation or service manual.
ATS fails to transfer the load to the emergency source after the generator set starts (Also see Figure 4-5)	Generator set circuit breaker is open.	Close circuit breakers leading from the generator set to the ATS.
	Time delay normal-to-emergency (TDNE) has not timed out.	Check operation. Enough time must pass for the time delay normal-to-emergency to time out.
	Generator voltage is out of range or emergency source sensing circuits are malfunctioning.	Check the emergency source voltage. Repair or adjust generator set if the output voltage is it is out of range, otherwise see Section 5.3.
	Transfer switch operation problems.	See Section 4.5, Transfer Switch Operation.
ATS fails to retransfer the load to the normal source after the normal source returns (Also see Figure 4-5)	Normal source circuit breaker is open.	Close circuit breakers leading from the normal source to the transfer switch.
	Emergency-to-normal retransfer time delay has not timed out.	Check time delay settings. See Figure 2-2. Enough time must elapse for the time delay emergency-to-normal timer to time out.
	Normal source voltage levels are out of range.	Check the normal source voltage. See Section 5.1.
	Normal source sensing circuits are malfunctioning.	See Section 5.2, Normal Source Sensing.
	Transfer switch operation problems.	See Section 4.5, Transfer Switch Operation.
Transfer switch mechanism is binding	Debris is in the transfer switch mechanism.	Clean the transfer switch assembly. See Section 3.2.2.
	Transfer switch mechanism is damaged.	Replace the transfer switch assembly. See Section 7.4.
ATS operates erratically or operates out of specifications	Power supply problems/loose connections, incorrect transfer switch controller operation/calibration.	For erratic operation, check wiring for loose connections especially those that supply power to the controller or in the affected circuit. Check the power supply. See Section 5.1. See Section 5.4 for problems related to time delays in the operating sequence. For problems related to dropout and pickup specifications see Section 5.2 for the normal source or Section 5.3 for the emergency source.

Troubleshooting Chart		
Problem	Possible Cause	Corrective Action
Source available LED off when Source is available	Controller does not recognize an available source.	Check switches, circuit breakers for open circuit.
		Check source connections to the ATS.
	Check source voltage and compare to source pickup and dropout levels. See Sections 2.5.1 and 5.1.	
	Malfunctioning LED.	Replace the controller's switch/LED membrane if one or more LEDs do not light. If no LEDs light, troubleshoot power and connections to the controller.
	Controller does not recognize an available source.	Check source sensing. See Sections 5.2 and 5.3.
Position LED not lit	Position microswitch malfunction.	Check the operation of the position microswitches. See Section 5.9.
	Transfer switch in intermediate position.	Manually operate the transfer switch and check the position LED operation. See Section 2.6. Check for evidence of solenoid coil damage. Replace the solenoid assembly if necessary. See the Table of Contents to locate solenoid assembly replacement procedures for your model transfer switch.
	LEDs not functioning.	Replace the controller's switch/LED membrane if one or more LEDs do not light. If no LEDs light, troubleshoot power and connections to the controller.
Exerciser does not operate when expected (Also see Figure 4-4)	Controller reset has cleared the exercise timer.	Set the exerciser on the desired time and day.

Figure 4-1 Troubleshooting Chart

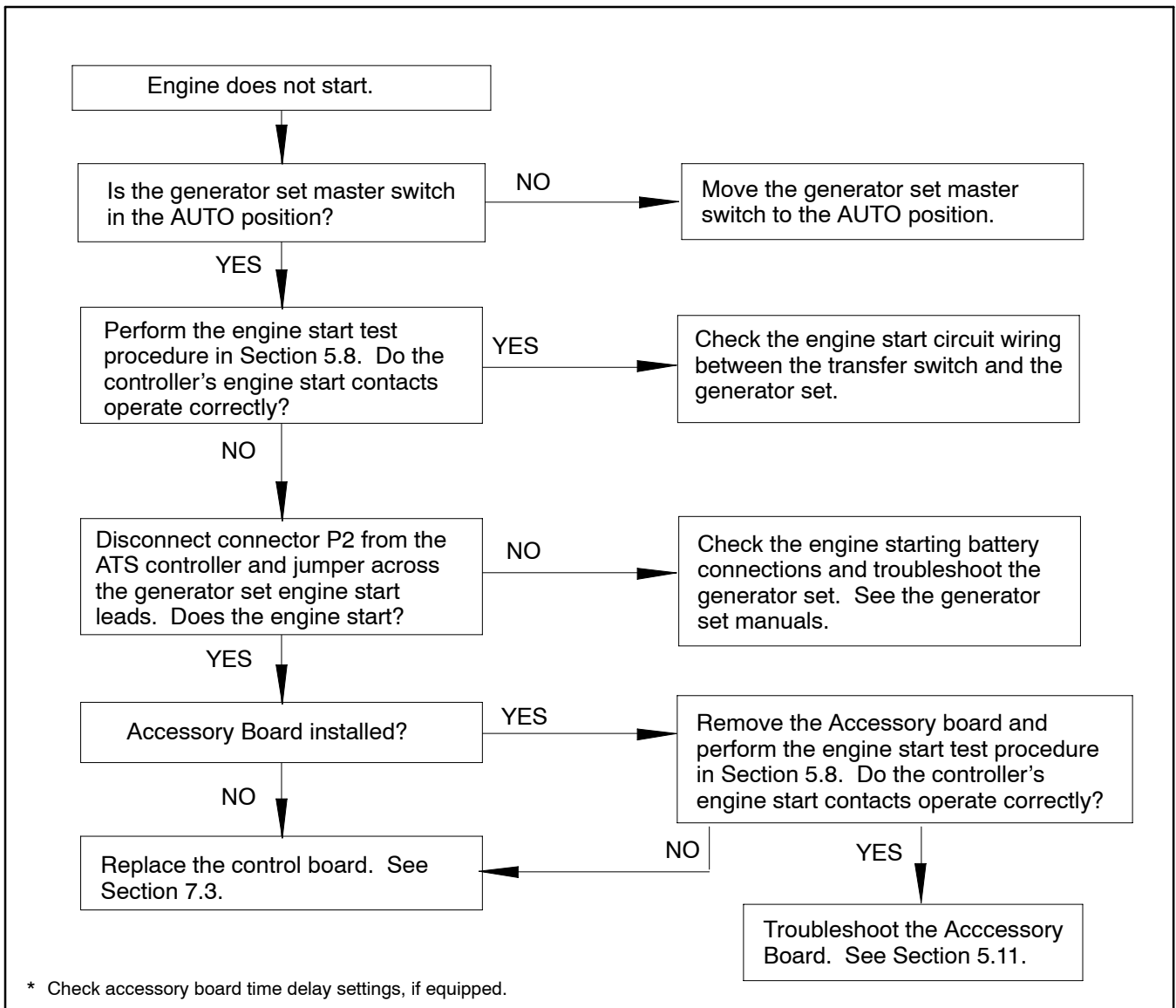

Figure 4-2 Troubleshooting Engine Start

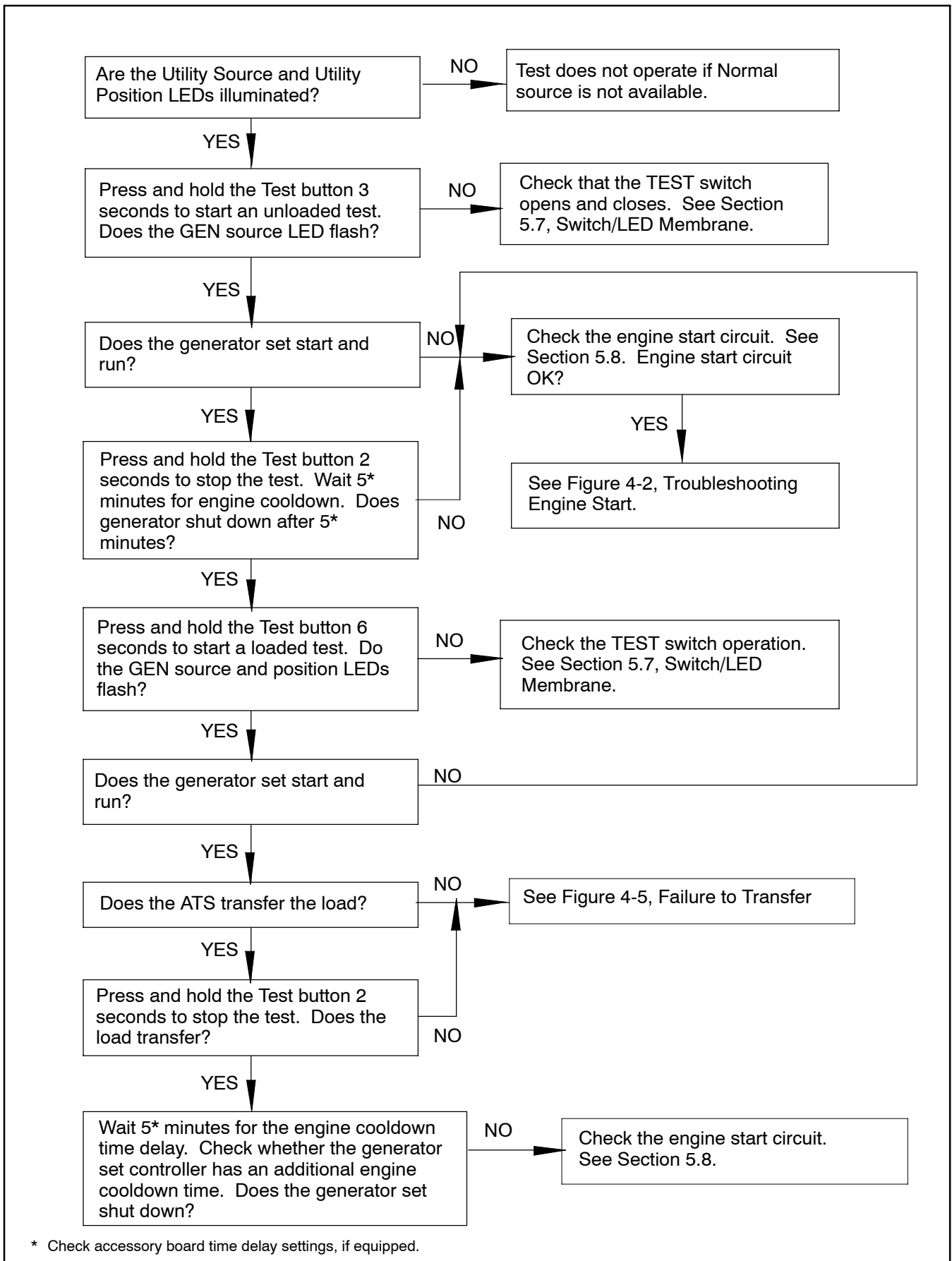

Figure 4-3 Troubleshooting the Test Button Operation

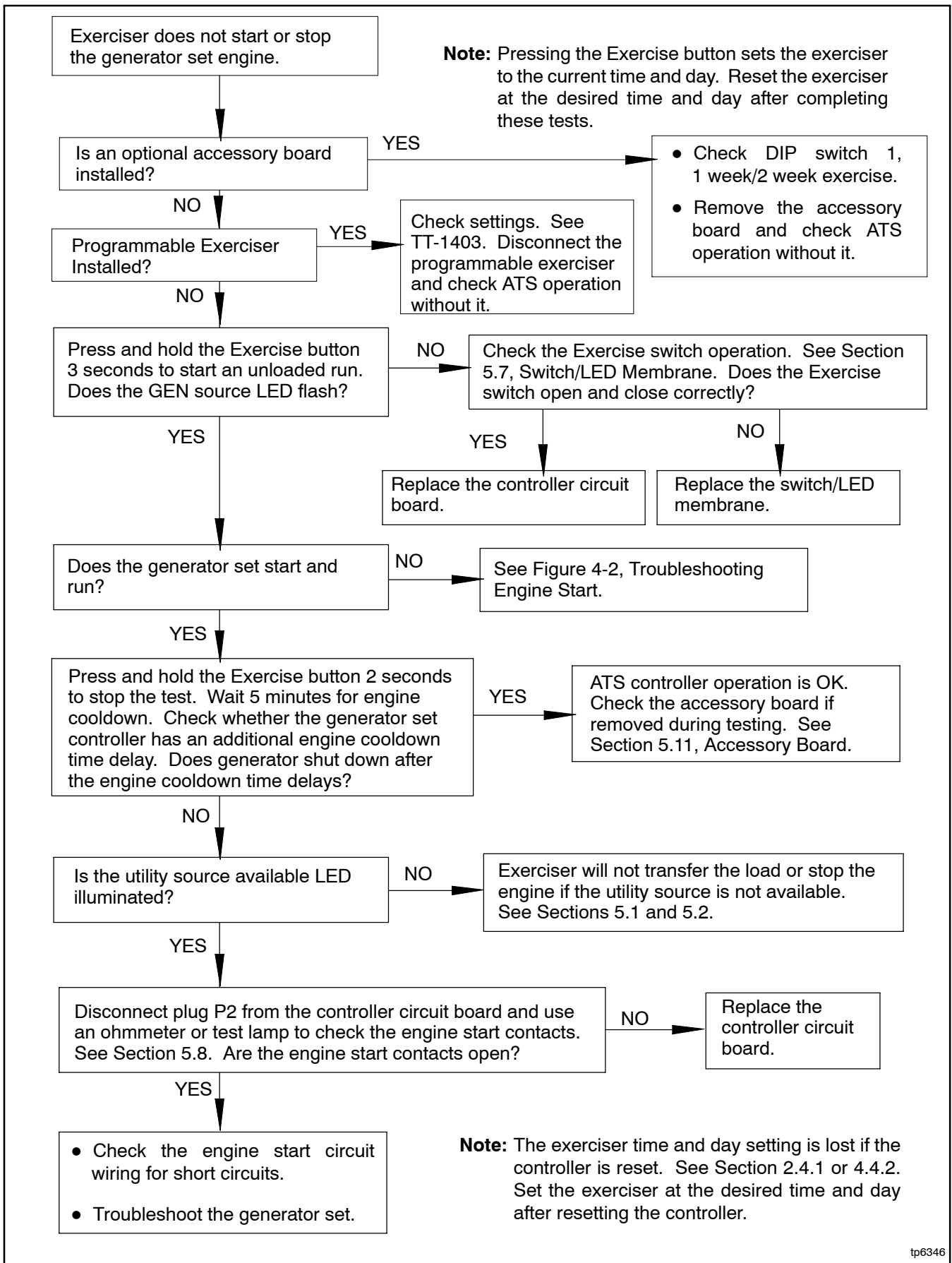

Figure 4-4 Exerciser Troubleshooting

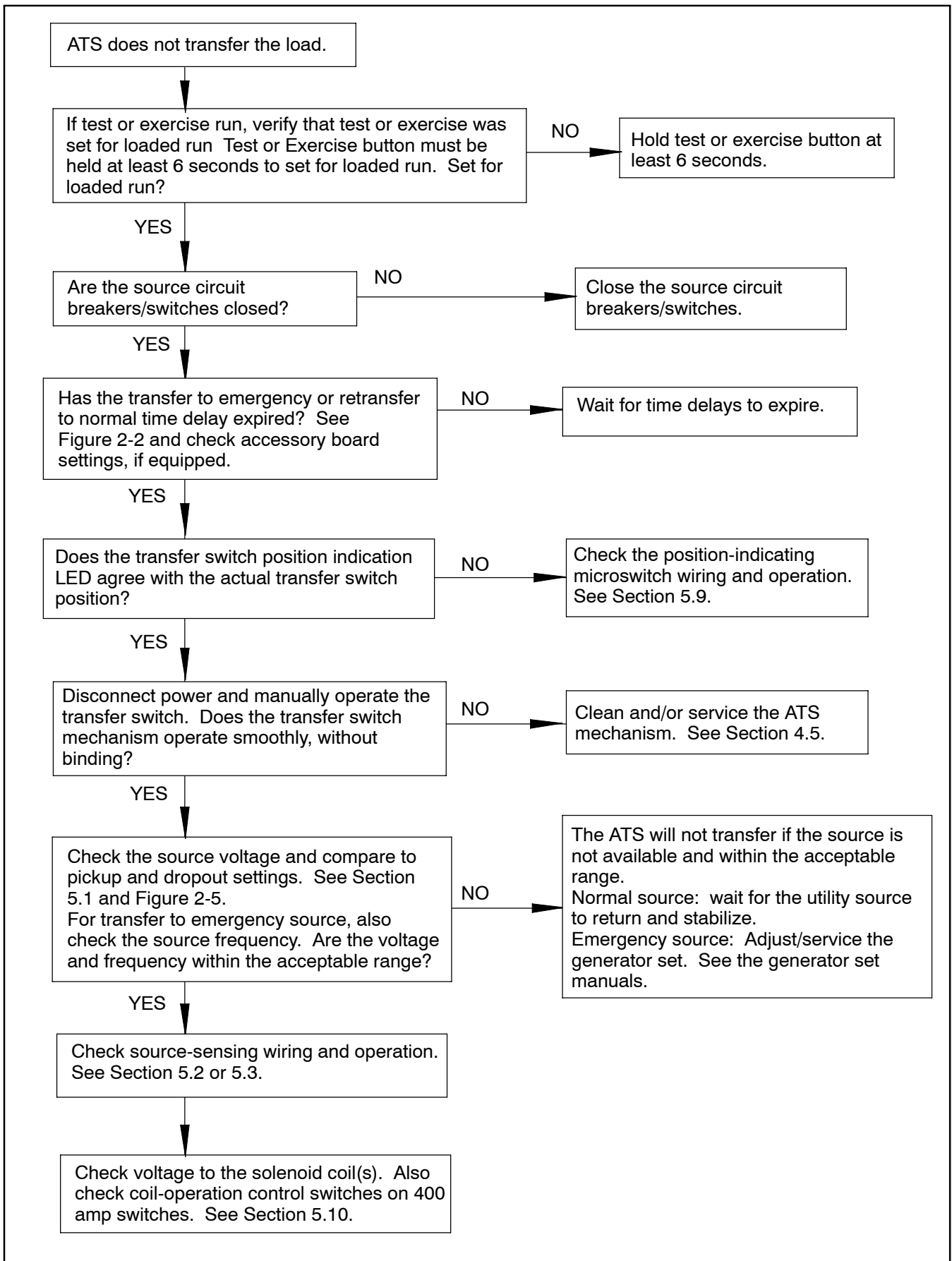

Figure 4-5 Failure to transfer

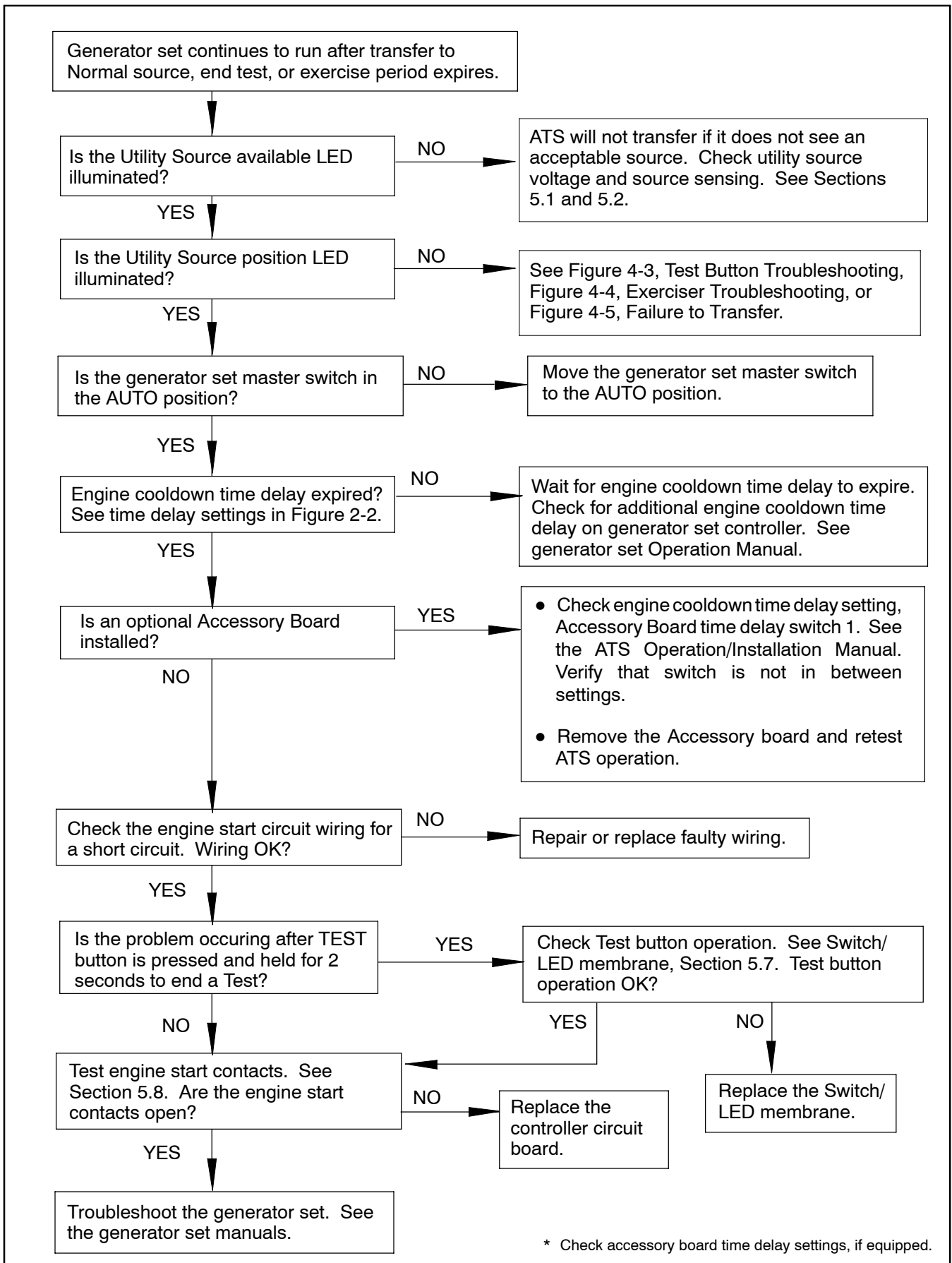

Figure 4-6 Generator Set Continues to Run

4.3 Faults

The LEDs on the controller's user interface flash as shown in Figure 4-7 to indicate various fault conditions. See Figure 4-8 to diagnose and correct the cause of the fault.

4.3.1 Failure to Acquire Emergency Source Warning

The Failure to Acquire Emergency Source fault occurs if the transfer switch does not sense voltage from the generator set within 75 seconds after signaling the generator set to start. 75 seconds allows for three 15-second crank attempts separated by 15-second rests. Check the engine start circuit and the generator set operation in the case of this fault.

The fault clears when the system acquires the emergency source.

The Failure to Acquire Emergency Source fault will occur if the generator set shuts down when the engine start contacts are closed. For example, shutting the generator set down by moving the master switch to OFF during the engine cooldown time delay will cause a Failure to Acquire Emergency Source fault condition on the ATS. Determine the reason for the generator set shutdown and then reset the fault as described in Section 4.4.1.

4.3.2 Failure to Transfer Warning

The Failure to Transfer warning occurs if a signal to transfer is sent to the contactor and the position-indicating contacts do not indicate a complete transfer.

The controller will attempt to transfer three times before indicating the fault. If the transfer switch is in the Normal position, the Engine Cooldown time delay is executed and then the engine start contacts open to stop the generator set.

See Section 4.4.1 to reset the fault condition.

4.3.3 Auxiliary Switch Fault

An Auxiliary Switch fault occurs if the position-indicating contacts indicate that the ATS position changed when no transfer was called for. If the transfer switch is in the Normal position, the Engine Cooldown time delay is executed and then the engine start contacts open to stop the generator set.

An Auxiliary Switch fault also occurs if both auxiliary switches are open or closed so that the controller is unable to determine the transfer switch position.

See Section 4.4.1 to reset the fault condition.

4.4 Resetting the Controller

4.4.1 Fault Reset

Always identify and correct the cause of a fault condition before resetting the ATS controller. Press and hold the Exercise and Test buttons for approximately 3 seconds until the LEDs flash to clear faults and warnings. Warnings reset automatically with a change in the source availability or a signal to transfer.

4.4.2 Controller Reset

Press and hold both buttons for 6 seconds to reset the controller to its original state at powerup.

Note: Resetting the controller clears the exerciser setting. Set the exercise time and day as described in Section 2.4 after resetting the controller.

4.4.3 Alarm Silence

If the transfer switch is equipped with an optional Accessory Board, pressing both buttons will also silence the alarm horn.

Condition	LED Indication
Utility source power available	Utility Source Available LED lights steadily.
Load connected to utility power	Utility Source Position LED lights steadily.
Generator set power available	GEN Source Available LED lights steadily.
Load connected to the generator set	GEN Position LED lights steadily.
Loaded test	GEN Available and GEN Position LEDs flash on 1 second, off 1 second.
Unloaded test	GEN Available LED flashes on 1 second, off 1 second.
Loaded exercise	GEN Available and GEN Position LEDs flash on 0.5 second, off 2 seconds.
Unloaded exercise	GEN Available LED flashes on 0.5 second, off 2 seconds.
Failure to acquire standby source fault	GEN Available LED flashes 2 times/second.
Failure to transfer fault	GEN or Utility Source Position LED flashes 2 times/second.
Auxiliary switch failure fault	GEN Position and Utility Source Position LEDs flash alternately 2 times/second.

Figure 4-7 LED Indication

Fault and Indication	Possible cause	Check
Failure to Transfer GEN or Utility Source Position LED flashes 2 times/second.	Source not available	Check source voltage, frequency, stability.
	Controller does not recognize an available source	Check switches, circuit breakers for open circuit.
		Check source connections to the ATS.
		Check source voltage and compare to source pickup and dropout levels. See Sections 5.2 and 5.3.
Transfer switch mechanism problem	See Section 4.5, Transfer Switch Operation.	
Auxiliary Switch Fault GEN Position and Utility Source Position LEDs flash alternately 2 times/second.	Controller cannot determine the transfer switch position	Check wiring and connections to position microswitches. See the schematic drawing for connections.
		Test position microswitch operation. Replace microswitch if necessary. See Section 7.
		Transfer switch in intermediate position. Disconnect power and manually operate the transfer switch. See instructions in the ATS Operation/Installation manual. Inspect for signs of coil damage or overheating and replace coil if necessary.
Failure to Acquire Standby GEN Available LED flashes 2 times/second.	Open circuit breaker	Check and close ATS source and generator set circuit breakers.
	Generator set did not start:	See below.
	Generator set master switch not in AUTO	Move generator set master switch to the AUTO position.
	Loose engine start connection	Check connections.
	No engine start command from ATS	See Section 5.8.
	Other generator set problem	Troubleshoot the generator set. See generator set service manual.
	ATS does not recognize the standby source	Check for loose source connections.
Check for open switch or circuit breaker.		
Check source voltage and frequency and compare to pickup and dropout levels. See Section 5.3.		

Figure 4-8 Faults

4.5 Transfer Switch Troubleshooting

Check the items in this section when the switch fails to transfer or transfers improperly when one source fails and the other source is available and is indicated by the corresponding source-available LED.

There may be both mechanical and electrical causes of transfer switch operation problems. If the transfer switch is binding, the transfer switch solenoid coil and other components could be damaged.

4.5.1 Neutral Connection

Check the neutral connection. The neutral connection is required for transfer switch operation.

4.5.2 Mechanical Check

Manually operate the transfer switch to check that it operates smoothly without binding.

If the transfer switch assembly is replaced, check the solenoid on the damaged transfer switch assembly before reapplying power. If the solenoid is damaged, visually check the wiring, controller assembly, and other components for evidence of overheating (discolored metal, burning odor or melted plastic). Replace damaged components.

4.5.3 Solenoid Troubleshooting

The solenoid coils require 120 VAC for operation. The rectifier is sealed inside the coil assembly and is not accessible for testing. During normal operation, the coils are energized for approximately 0.5 second to initiate transfer.

Visually inspect the coils for signs of overheating. A transfer switch solenoid is not designed to operate continuously. When operated continuously the solenoid coil windings first tend to short circuit, then eventually burn, and the solenoid becomes an open circuit. Therefore, a damaged solenoid most likely indicates that the transfer switch was mechanically binding or that something in the control circuit failed and allowed the solenoid to operate over a longer period than it should. See Section 5.10 to test the voltage to the solenoid coils and the coil operation control switches (400 amp models).

Note: Checking the voltage to the coil requires a fast (250 microseconds) digital multimeter with a maximum recording feature.

After solenoid replacement and before applying power:

- Check that the transfer switch operates freely without binding.
- Visually check the wiring, controller assembly, and other components for evidence of overheating (discolored metal, burning odor or melted plastic). Replace damaged components.

Section 5 Component Testing

This section contains component testing information.

Note: Only trained qualified personnel following all applicable codes and standards should attempt to service the transfer switch.

Observe all safety precautions while servicing the transfer switch.

WARNING



Accidental starting. Can cause severe injury or death.

Disconnect the battery cables before working on the generator set. Remove the negative (-) lead first when disconnecting the battery. Reconnect the negative (-) lead last when reconnecting the battery.

Disabling the generator set. Accidental starting can cause severe injury or death. Before working on the generator set or connected equipment, disable the generator set as follows: (1) Move the generator set master switch to the OFF position. (2) Disconnect the power to the battery charger. (3) Remove the battery cables, negative (-) lead first. Reconnect the negative (-) lead last when reconnecting the battery. Follow these precautions to prevent starting of the generator set by an automatic transfer switch, remote start/stop switch, or engine start command from a remote computer.

WARNING

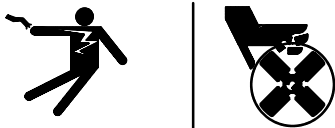

Hazardous voltage. Moving rotor. Can cause severe injury or death.

Operate the generator set only when all guards and electrical enclosures are in place.

Grounding electrical equipment. Hazardous voltage can cause severe injury or death. Electrocutation is possible whenever electricity is present. Open the main circuit breakers of all power sources before servicing the equipment. Configure the installation to electrically ground the generator set, transfer switch, and related equipment and electrical circuits to comply with applicable codes and standards. Never contact electrical leads or appliances when standing in water or on wet ground because these conditions increase the risk of electrocution.

Connecting the battery and the battery charger. Hazardous voltage can cause severe injury or death. Reconnect the battery correctly, positive to positive and negative to negative, to avoid electrical shock and damage to the battery charger and battery(ies). Have a qualified electrician install the battery(ies).

DANGER



Hazardous voltage. Will cause severe injury or death.

Disconnect all power sources before opening the enclosure.

DANGER



Hazardous voltage. Will cause severe injury or death.

Only authorized personnel should open the enclosure.

Servicing the transfer switch. Hazardous voltage can cause severe injury or death. Deenergize all power sources before servicing. Open the main circuit breakers of all transfer switch power sources and disable all generator sets as follows: (1) Move all generator set master controller switches to the OFF position. (2) Disconnect power to all battery chargers. (3) Disconnect all battery cables, negative (-) leads first. Reconnect negative (-) leads last when reconnecting the battery cables after servicing. Follow these precautions to prevent the starting of generator sets by an automatic transfer switch, remote start/stop switch, or engine start command from a remote computer. Before servicing any components inside the enclosure: (1) Remove all jewelry. (2) Stand on a dry, approved electrically insulated mat. (3) Test circuits with a voltmeter to verify that they are deenergized.

Servicing the transfer switch controls and accessories within the enclosure. Hazardous voltage can cause severe injury or death. Disconnect the transfer switch controls at the inline connector to deenergize the circuit boards and logic circuitry but allow the transfer switch to continue to supply power to the load. Disconnect all power sources to accessories that are mounted within the enclosure but are not wired through the controls and deenergized by inline connector separation. Test circuits with a voltmeter to verify that they are deenergized before servicing.

Short circuits. Hazardous voltage/current can cause severe injury or death. Short circuits can cause bodily injury and/or equipment damage. Do not contact electrical connections with tools or jewelry while making adjustments or repairs. Remove all jewelry before servicing the equipment.

Testing live electrical circuits. Hazardous voltage or current can cause severe injury or death. Have trained and qualified personnel take diagnostic measurements of live circuits. Use adequately rated test equipment with electrically insulated probes and follow the instructions of the test equipment manufacturer when performing voltage tests. Observe the following precautions when performing voltage tests: (1) Remove all jewelry. (2) Stand on a dry, approved electrically insulated mat. (3) Do not touch the enclosure or components inside the enclosure. (4) Be prepared for the system to operate automatically.
(600 volts and under)

NOTICE

Electrostatic discharge damage. Electrostatic discharge (ESD) damages electronic circuit boards. Prevent electrostatic discharge damage by wearing an approved grounding wrist strap when handling electronic circuit boards or integrated circuits. An approved grounding wrist strap provides a high resistance (about 1 megohm), *not a direct short*, to ground.

5.1 System Power

The voltage and frequency of the transfer switch and the power sources must be the same to avoid damage to loads and the transfer switch. Compare the voltage and frequency ratings of the utility source, transfer switch, and generator set, and verify that the ratings are all the same.

Read and understand all instructions on installation drawings and labels on the switch. Note any optional accessories that have been furnished with the switch and review their operation.

Refer to Figure 5-1 through Figure 5-3 and the wiring diagrams in Section 6, as required.

The voltage check procedure requires a digital voltmeter (DVM) with electrically insulated probes capable of measuring the rated voltage and frequency.

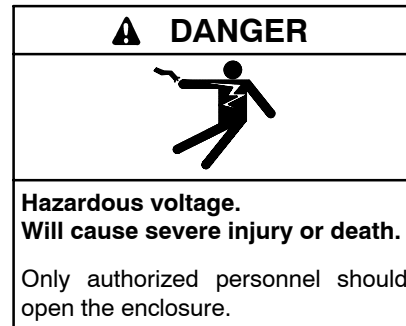

Testing live electrical circuits. Hazardous voltage or current can cause severe injury or death. Have trained and qualified personnel take diagnostic measurements of live circuits. Use adequately rated test equipment with electrically insulated probes and follow the instructions of the test equipment manufacturer when performing voltage tests. Observe the following precautions when performing voltage tests: (1) Remove all jewelry. (2) Stand on a dry, approved electrically insulated mat. (3) Do not touch the enclosure or components inside the enclosure. (4) Be prepared for the system to operate automatically.
(600 volts and under)

Source Voltage and Frequency Check Procedure

1. Verify that the generator set master switch is in the OFF position and both power sources are disconnected from the transfer switch.
2. Disconnect the transfer switch wiring harness from the P1 connector on the controller's main logic board. See Figure 5-1.

Note: Do not connect or disconnect the controller wiring harness when the power is connected.
3. Manually operate the transfer switch to position E. See the Transfer Switch Operation and Installation Manual for manual operation instructions.
4. Close the utility source circuit breaker or switch.

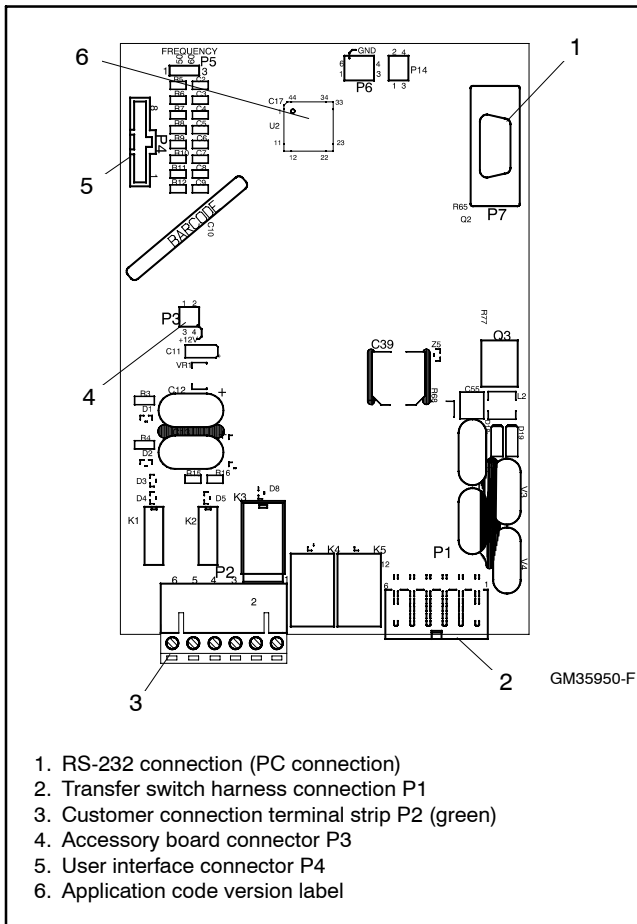

Figure 5-1 Controller Board Connections

5. Use a voltmeter to check the utility source voltage and frequency to the transfer switch. See Figure 5-2 or Figure 5-3.
 - a. Check for 240 VAC across lugs NL1 and NL2.
 - b. Check for 120 VAC from NL1 to neutral.
 - c. Check for 120 VAC from NL2 to neutral.
 - d. Check for 240 VAC across P1-7 and P1-8 at controller connector P1.
6. Disconnect Source N by opening upstream circuit breakers or switches.
7. Manually operate the transfer switch to position N.
8. Move the generator set master switch to RUN.

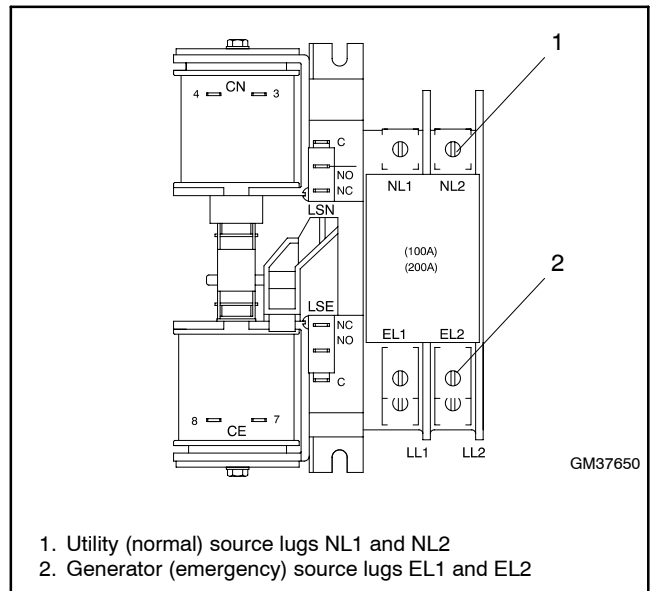

Figure 5-2 Source Lugs, 100 and 200 Amp Models

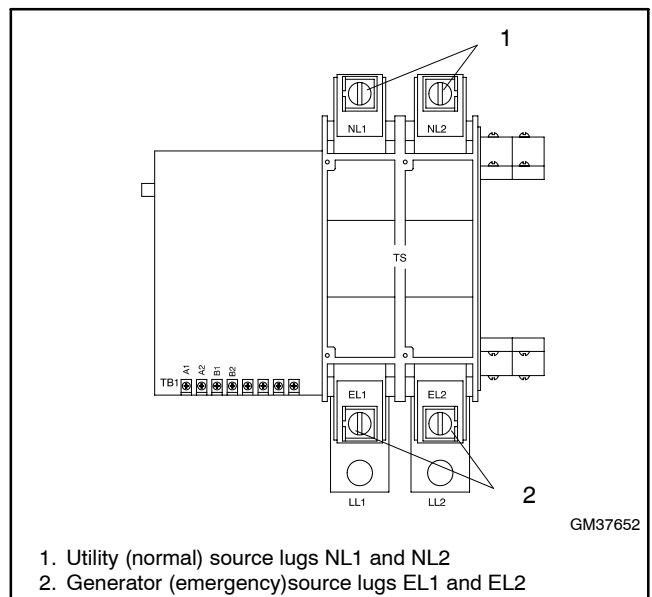

Figure 5-3 Source Lugs, 400 Amp Models

9. Use a voltmeter to check the generator source voltages and frequency at lugs EL1 and EL2. See Figure 5-2 or Figure 5-3.
 - a. Check for 240 VAC across lugs EL1 and EL2.
 - b. Check the source frequency at EL1 and EL2.
 - c. Check for 120VAC from EL1 to neutral.
 - d. Check for 120 VAC from EL2 to neutral.
 - e. Check for 240 VAC across P1-1 and P1-2 at controller connector P1.

10. If the generator set output voltage and frequency do not match the nominal system voltage and frequency shown on the transfer switch nameplate, follow the manufacturer's instructions to adjust the generator set. The automatic transfer switch will only function with the rated system voltage and frequency specified on the nameplate.
11. Stop the generator set by moving the master switch to the OFF position.
12. Disconnect both sources to the transfer switch by opening the circuit breakers or switches.
13. Connect the transfer switch wiring harness to the controller at connector P1.

Note: Do not connect or disconnect the controller wiring harness when the power is connected.

14. Close and lock the transfer switch enclosure door.
15. Reconnect both power sources by closing the circuit breakers or switches.
16. Move the generator set master switch to the AUTO position.

Note: If the engine cooldown time delay setting is not set to zero (default setting), the generator set may start and run until the Time Delay Engine Cooldown (TDEC) ends.

5.2 Normal Source Sensing

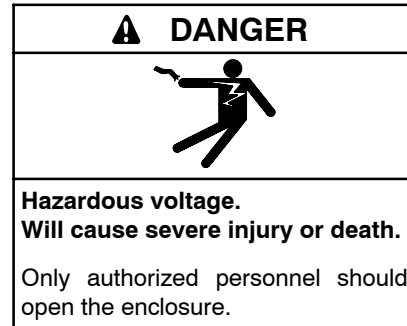

Testing live electrical circuits. Hazardous voltage or current can cause severe injury or death. Have trained and qualified personnel take diagnostic measurements of live circuits. Use adequately rated test equipment with electrically insulated probes and follow the instructions of the test equipment manufacturer when performing voltage tests. Observe the following precautions when performing voltage tests: (1) Remove all jewelry. (2) Stand on a dry, approved electrically insulated mat. (3) Do not touch the enclosure or components inside the enclosure. (4) Be prepared for the system to operate automatically. *(600 volts and under)*

Follow this section when the system fails to recognize the normal power source as available by lighting the Utility Available LED, or when it fails to recognize normal power source failure. See Figure 5-4 for pickup and dropout settings.

This section requires a voltmeter with a minimum accuracy of $\pm 1\%$ on the scale being measured.

Initial Normal Source Sensing Test

Use this section to initially check normal source sensing. This procedure requires normal source availability.

1. Disconnect the normal source. If the Utility Available LED remains lit for more than a few seconds, replace the controller assembly.
2. Reconnect the normal source and check for nominal line voltage on NL1 and NL2 on terminals P1-7 and P1-8 on the controller assembly.
 - a. If voltage is not present on terminals 7 and 8 and NL2 on P1 on the controller, check for voltage on lugs NL1 and NL2 on the transfer switch assembly. If voltage is not present on the lugs, check the normal source and the normal source wiring and circuit breaker. If voltage is present on the lugs, check the transfer switch wiring harness connections from the lugs to the controller assembly.
 - b. If the voltage on terminals 7 and 8 on P1 on the controller exceeds the pickup voltage (see

Figure 5-4) then the Utility Available LED on the controller assembly should light; replace the controller assembly if the LED does not light.

Use the following procedures to test normal source sensing operation and calibration.

Normal Source Sensing Accuracy Test

Follow the next steps to check the accuracy of normal-source voltage sensing. This procedure requires a variable voltage source that ranges from about 5% below the dropout specification to about 5% above the pickup specification.

1. Disconnect the normal and emergency power sources and the load from the transfer switch.
2. Connect a variable voltage source to lugs NL1 and NL2 on the transfer switch assembly. Increase the voltage until the Utility Available LED lights or the voltage is 5% above the pickup voltage specification in Figure 5-4.
3. If the Utility Available LED does not light, replace the controller assembly.
4. If the Utility Available LED lights, reduce the voltage until the Utility Available LED turns off or is 5% below the dropout voltage specification. If the Utility Available LED remains lit, replace the controller assembly. If the LED turns off, check the voltage. If the voltage is not within $\pm 5\%$ of the dropout voltage specification, replace the controller assembly.
5. Increase the voltage until the Utility Available LED lights. If the voltage is not within $\pm 5\%$ of the pickup specification, replace the controller assembly.

	% of Rated	240 V	220 V
Undervoltage dropout	80%	192 VAC	176 VAC
Undervoltage pickup	85%	204 VAC	187 VAC

Figure 5-4 Normal Source Sensing

5.3 Emergency Source Sensing

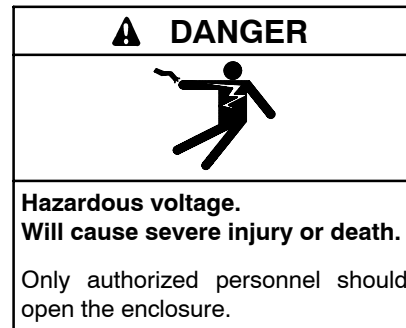

Testing live electrical circuits. Hazardous voltage or current can cause severe injury or death. Have trained and qualified personnel take diagnostic measurements of live circuits. Use adequately rated test equipment with electrically insulated probes and follow the instructions of the test equipment manufacturer when performing voltage tests. Observe the following precautions when performing voltage tests: (1) Remove all jewelry. (2) Stand on a dry, approved electrically insulated mat. (3) Do not touch the enclosure or components inside the enclosure. (4) Be prepared for the system to operate automatically. *(600 volts and under)*

Follow this section when the transfer switch starts the generator set but does not recognize the emergency source as available by lighting the GEN LED, or it fails to recognize emergency power source failure.

This section requires a voltmeter with a minimum accuracy of $\pm 1\%$ on the scale being measured.

Initial Emergency Source Sensing Test

Use this section to initially check emergency source sensing. This procedure requires emergency source availability.

1. Move the generator set master switch to the RUN position to start the emergency source generator set.
2. Disconnect the emergency source. If the GEN LED remains lit more than a few seconds, replace the controller assembly.
3. Reconnect the emergency source and check for nominal line voltage between pins 1 and 2 at connector P1 to the controller assembly.
 - a. If voltage is not present at the controller, check for voltage on lugs GL1 and GL2 on the transfer switch assembly. If voltage is not present at the lugs, check the emergency source and the emergency source wiring and circuit breaker. If voltage is present at the lugs, check the transfer switch wiring harness connections from the lugs to the controller.

- b. If the voltage at pins 1 and 2 on P1 on the controller exceeds the pickup voltage specification in Figure 5-5, the GEN LED on the controller assembly should light; replace the controller assembly if the GEN LED does not light.

	% of Rating	240 Volt 60 Hz	220 Volt 50 Hz
Undervoltage dropout	80%	192	176
Undervoltage pickup	85%	204	187
Underfrequency dropout *	90%	54	45
Underfrequency pickup *	96%	57.6	48
* Emergency (GEN) source only			

Figure 5-5 Emergency Source Sensing

Use the following procedure to test emergency source sensing operation and calibration.

Emergency Source Voltage Sensing Accuracy Test

Follow the next steps to check the accuracy of emergency source voltage sensing. This procedure requires a variable voltage source that ranges from about 5% below the dropout specification to about 5% above the pickup specification. See Figure 5-5.

1. Disconnect the normal and emergency power sources and the load from the transfer switch.
2. Connect a variable voltage source that ranges from about 5% below the dropout specification to about

5% above the pickup specification to lugs GL1 and GL2 on the transfer switch assembly.

3. Increase the voltage until the GEN LED lights or the voltage is 5% above the pickup voltage specification. If the GEN LED does not light, replace the controller assembly. Otherwise, reduce the voltage until the GEN LED turns off or the voltage is 5% below the dropout voltage specification.
4. If the GEN LED remains lit, replace the controller assembly. If the LED turns off, check the voltage. If the voltage is not within $\pm 5\%$ of the dropout voltage specification, replace the controller assembly.
5. Increase the voltage until the GEN LED lights. If the voltage is not within $\pm 5\%$ of the pickup voltage specification, replace the controller assembly.

Emergency Source Frequency Sensing Test

If the generator set frequency is adjustable, follow the instructions in the generator set manual to adjust the frequency above and below the pickup and dropout settings. Use a digital multimeter to measure to source frequency.

Note: Carefully follow the instructions and safety precautions in the generator set manual.

Check the operation of the GEN LED on the ATS as the frequency is increased and decreased. The ATS frequency sensing should be accurate to $\pm 2\%$.

5.4 Controller Operation Test

Follow this section to check the automatic operation sequence including LED functions, engine starting, time delays, and transfer switch operation. See Figure 5-6 for time delays.

This test differs from a test sequence initiated by the Test button on the controller keypad. This sequence simulates the loss of normal power by disconnecting the source and executes all applicable time delays.

If the unit is equipped with the optional accessory board, check the time delay adjustment switch settings on the optional board. See the Operation/Installation Manual for time delay adjustment instructions.

Controller Operation Test

1. Move the generator set master switch to the OFF position.
2. Disconnect ALL power sources to the transfer switch.
3. Manually operate the transfer switch to the normal position.

Note: Do not manually operate the transfer switch with the power connected.

4. Close and secure the enclosure door.
5. Apply the normal power source and wait for the engine cooldown time delay. If the Utility Available LED does not light, see Section 5.2. If the Utility Available LED lights but the engine-start contact does not open within $\pm 10\%$ of the engine cooldown time delay, replace the controller assembly.
6. Move the generator set master switch to the AUTO position.
7. Disconnect the normal power source and wait for the engine start time delay. If the the engine-start contact does not close within $\pm 10\%$ of the engine start time delay setting, replace the controller assembly.
8. Reconnect the emergency source and check the GEN LED. If the GEN LED does not light, see Section 5.3. Wait for the Normal-to-Emergency transfer time delay and the switch to transfer to the emergency source. If the switch fails to transfer, see Section 5.1. If the switch transfers but not within $\pm 10\%$ of the Normal-to-Emergency transfer time delay setting, replace the controller assembly.

9. Reconnect the normal power source. Wait for the Emergency-to-Normal retransfer time delay and for the switch to transfer back to the normal source. If the switch fails to transfer, see Section 5.1. If the switch transfers but not within $\pm 10\%$ of the Emergency-to-Normal retransfer time delay setting, replace the controller assembly.
10. Wait for the engine cooldown time delay. If the engine-start contact does not open within $\pm 10\%$ of the engine cooldown time delay setting (after transfer to normal), replace the controller assembly.

Time Delays			
Time Delay	Factory Setting	Adjustment with Accessory Board*	
		Range	Increment
Engine Start	3 sec.	1-10 sec.	1 sec.
Transfer from Normal to Emergency	3 sec.	1-10 sec.	1 sec.
Retransfer from Emergency to Normal	6 min.	3-30 min.	3 min.
Engine Cooldown	5 min.	1-10 min.	1 min.
Failure to Acquire Emergency	78 sec.†	NA	
Exercise Time Duration	20 min.	5-50 min.	5 min.
Undervoltage Dropout Time	0.5 sec.	NA	
Underfrequency Dropout Time	3 sec.	NA	
* Optional accessory board required for time delay adjustments. NA = not adjustable			
† Allows for three 15 sec. crank attempts separated by two 15 sec. rest periods.			

Figure 5-6 Time Delays

5.5 Controller Monitoring Using Hyper Terminal

The Hyper Terminal program on personal computers (PCs) equipped with Windows operating systems can be used to check the source voltages and frequencies, transfer switch position, time delays, and exerciser settings.

Use a null modem cable to connect the RS-232 port on the controller's main logic circuit board to the serial port on the PC. See Figure 5-1 for the RS-232 port location.

HyperTerminal Setup

1. Start the Hyper Terminal program by clicking on the Start button on the PC screen and selecting:

Programs→ Accessories→ Communications→ Hyper Terminal

After the HyperTerminal program opens, dialogue boxes will appear on the screen to help you set up the connection.

2. Choose a name for the connection. Type the name into the Name box, select an icon if desired, and click OK.
3. In the next window, select the PC's serial port that is connected to the ATS (for example, COM1) in the *Connect Using* box.
4. Set the serial parameters to the values shown in Figure 5-7.

Parameter	Setting
Bits/Sec	19200
Databits	8
Parity	none
Stop bits	1
Flow control	Xon Xoff

Figure 5-7 Hyper Terminal Serial Settings

5. To connect to the ATS, select Call→ Call from the menubar or click on the telephone button. See Figure 5-8. When the connection is established, data similar to that shown in Figure 5-8 will begin to appear on the screen. New data appears every 30 seconds or so.
6. To disconnect, select Call→ Disconnect or click on the hang-up button on the toolbar. See Figure 5-8.
7. Select File→ Save to save the monitoring session and the communication parameters to the filename chosen in step 2. Saving the session allows you to reconnect without resetting the communication parameters.
8. Select File→ Exit to close Hyper Terminal.

After the first session has been saved to a file, select Start→ Programs→ Accessories→ Communications→ Hyper Terminal→ <filename.ht> to reconnect to the ATS for additional monitoring. The filename is the name selected in step 2 with the extension *.ht* (test.ht in this example). The session connects automatically.

The data shown in HyperTerminal alternates between two sets. See Figure 5-8.

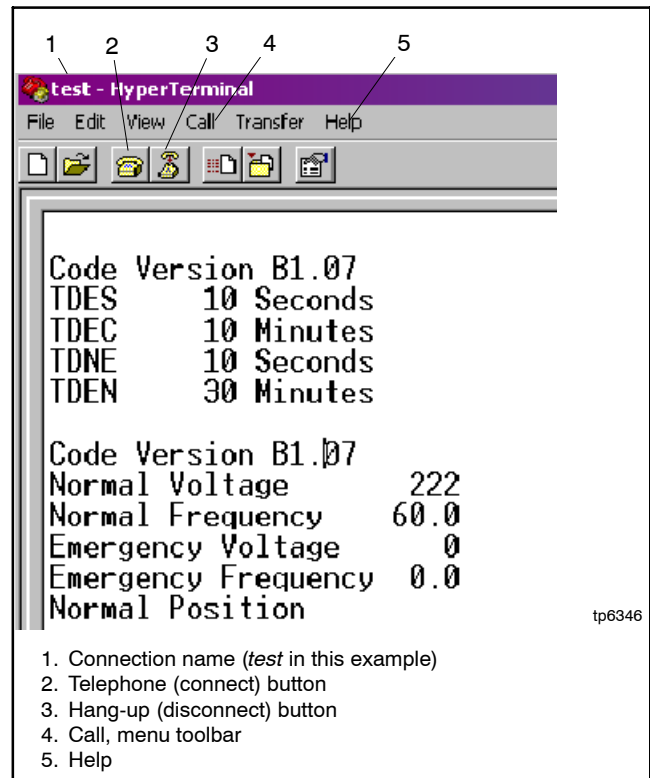

Figure 5-8 Typical Hyper Terminal Screen

The first line of data shown in each set is the application code version installed on the ATS controller's main logic board. (The application code can be updated using Program Loader software. See TT-1285, Program Loader Instructions.)

The first data set shows the time delay and exerciser settings on the transfer switch. The second data set shows the measured source voltage and frequency and the transfer switch position. *Exerciser Active* or *Test Mode Active* will appear if an exercise or a test is running.

Click on Help for more information about using Hyper Terminal.

5.6 Controller Application Code

A label on the controller circuit board shows the application code version loaded at the factory. The code version can be verified by connecting a personal computer and running Hyper Terminal as described in Section 5.5.

The controller application code can be reloaded or updated using a personal computer running Program Loader software. Refer to TT-1285, Program Loader, and the TechTools website for instructions to obtain and load the latest code version. Make a note of the code version loaded for future reference.

5.7 Switch/LED Membrane

The switch/LED membrane ribbon cable connects to the controller circuit board at connector P4. To check the operation of the test and exercise switches, disconnect the ribbon cable at P4. Use an ohmmeter or test lamp across pins 1 and 2 or 1 and 3 to check switch operation. See Figure 5-9.

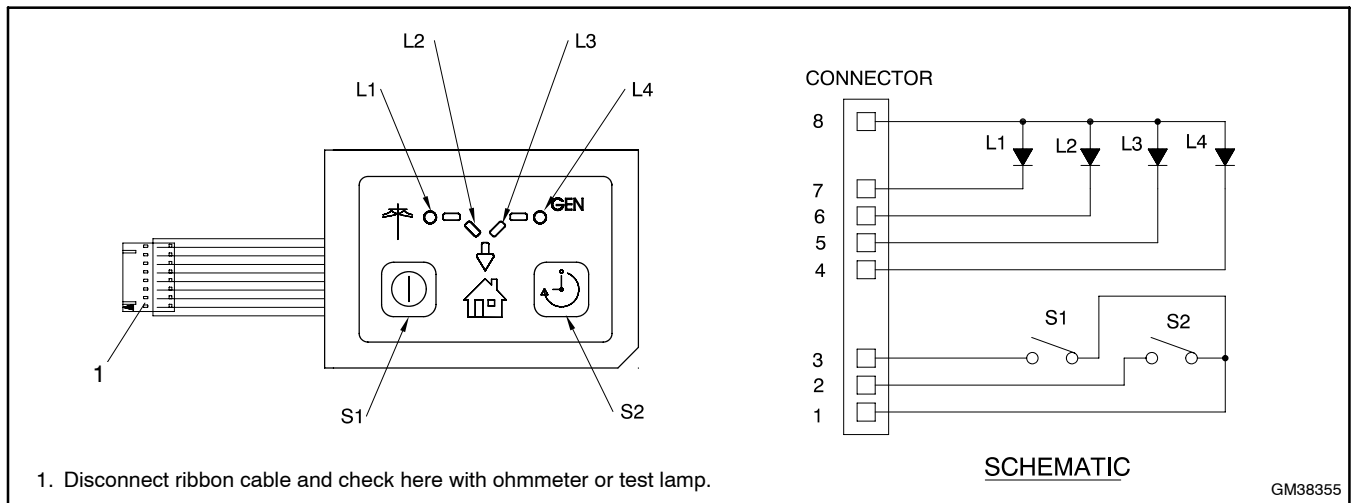

Figure 5-9 Switch/LED Membrane

5.8 Engine Start Contact Test

Follow this section when the transfer switch does not start the generator set engine during a loss of Utility power, a test sequence, or an exercise period.

See Figure 5-10 for the engine start connection to the ATS controller circuit board (connector P2).

Check the following items first:

- Verify that the generator set master switch is in the AUTO position and the engine starting battery is connected and charged.
- Check the engine start lead connections to terminals 3 and 4 on plug P2.
- Disconnect the P2 connector from the ATS controller circuit board. Place a jumper across the generator set engine start leads and verify that the engine starts.
- Check the engine start circuit wiring from the ATS to the generator set for shorts and open circuits.

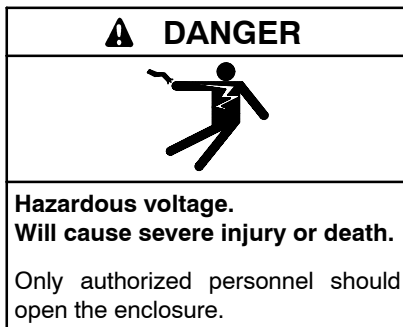

Testing live electrical circuits. Hazardous voltage or current can cause severe injury or death. Have trained and qualified personnel take diagnostic measurements of live circuits. Use adequately rated test equipment with electrically insulated probes and follow the instructions of the test equipment manufacturer when performing voltage tests. Observe the following precautions when performing voltage tests: (1) Remove all jewelry. (2) Stand on a dry, approved electrically insulated mat. (3) Do not touch the enclosure or components inside the enclosure. (4) Be prepared for the system to operate automatically.
(600 volts and under)

The following procedure checks the operation of the engine start contacts. Also refer to the flowcharts in Figure 4-2 and Figure 4-6.

See Figure 5-6 for time delays. If the unit is equipped with the optional accessory board, check the settings for the engine start and engine cooldown time delays. See Figure 5-19 for the accessory board time delay switch locations.

Engine Start Contact Test Procedure

1. Move the generator set master switch to the OFF position.
2. Disconnect the generator set engine starting battery, negative (-) lead first.
3. Disconnect power to the transfer switch by opening the normal and emergency source circuit breakers.
4. Open the transfer switch enclosure and disconnect P2 from the ATS controller board. See Figure 5-10.
5. Connect an ohmmeter or test lamp across engine start terminals 3 and 4 on connector P2 on the controller assembly. Verify that the contacts are closed. If engine start contacts 3 and 4 are not closed, replace the controller circuit board.
6. Reconnect the normal source to the transfer switch. Continue to monitor the engine start contacts. Verify that the contacts open after the engine cooldown time delay expires.

If the engine start contacts do not operate correctly during the engine start test procedure:

- Troubleshoot the Accessory Board, if equipped. See Section 5.11. Remove the accessory board and repeat the engine start test procedure without it.
- If the engine start contacts do not operate correctly with the accessory board removed, replace the control board.

If the engine start contacts operate correctly during the engine start test procedure, refer to the generator set manuals to troubleshoot the generator set.

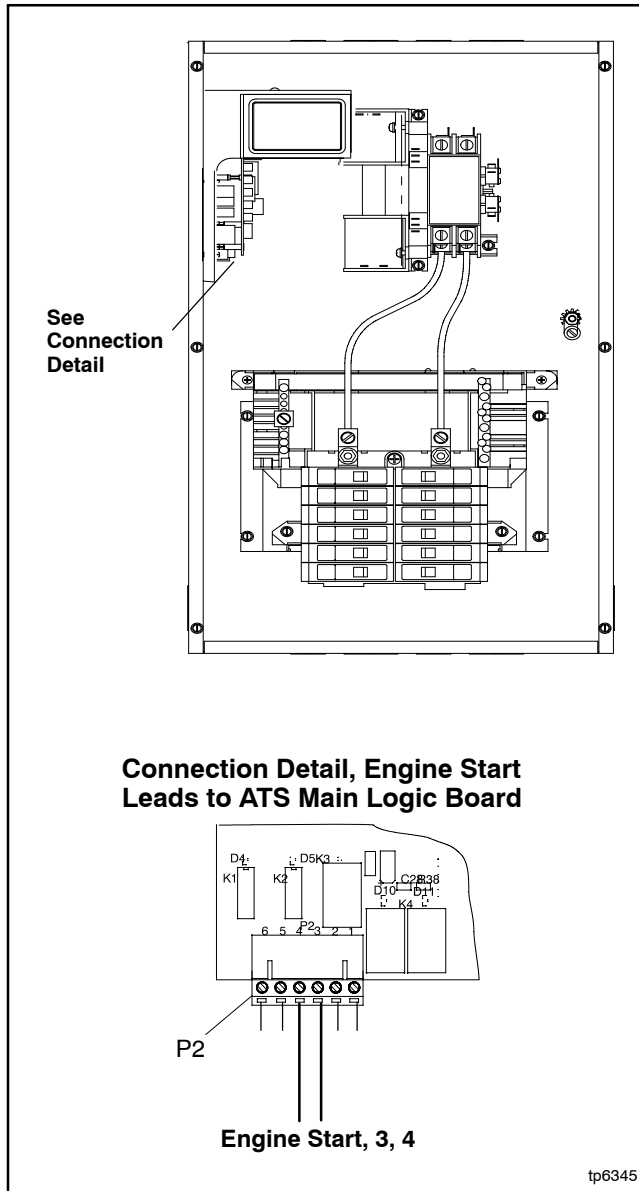

Figure 5-10 Engine Start Connection

5.9 Position-Indicating Microswitches

Check the position-indicating microswitch operation in the case of faulty position indication, failure to transfer fault, or auxiliary switch fault.

Disconnect power to the ATS before checking the switches.

Position-Indicating Microswitch Test Procedure

1. Move the generator set master switch to the OFF position.
2. Disconnect the engine starting battery, negative (-) lead first.
3. Disconnect the battery charger, if equipped.
4. Disconnect power to the ATS by opening the source circuit breakers or switches.
5. See Figure 5-11 or Figure 5-12 for the position-indicating microswitch locations.
6. Connect an ohmmeter or a test lamp across terminals NO (normally open) and C of switch LSN or SN2.
7. Manually operate the transfer switch. Check that the transfer switch lever operates the position-indicating switch and verify that the contact opens and closes. The NO contact should close when the switch is pressed and open when the switch is released.
8. Repeat steps 6 and 7 for the NC (normally closed) contact. The NC contact should open when the switch is pressed and close when the switch is released.
9. Verify that there is no continuity between the NO and NC terminals.
10. Repeat steps 6 through 9 for switch LSE or SE2.

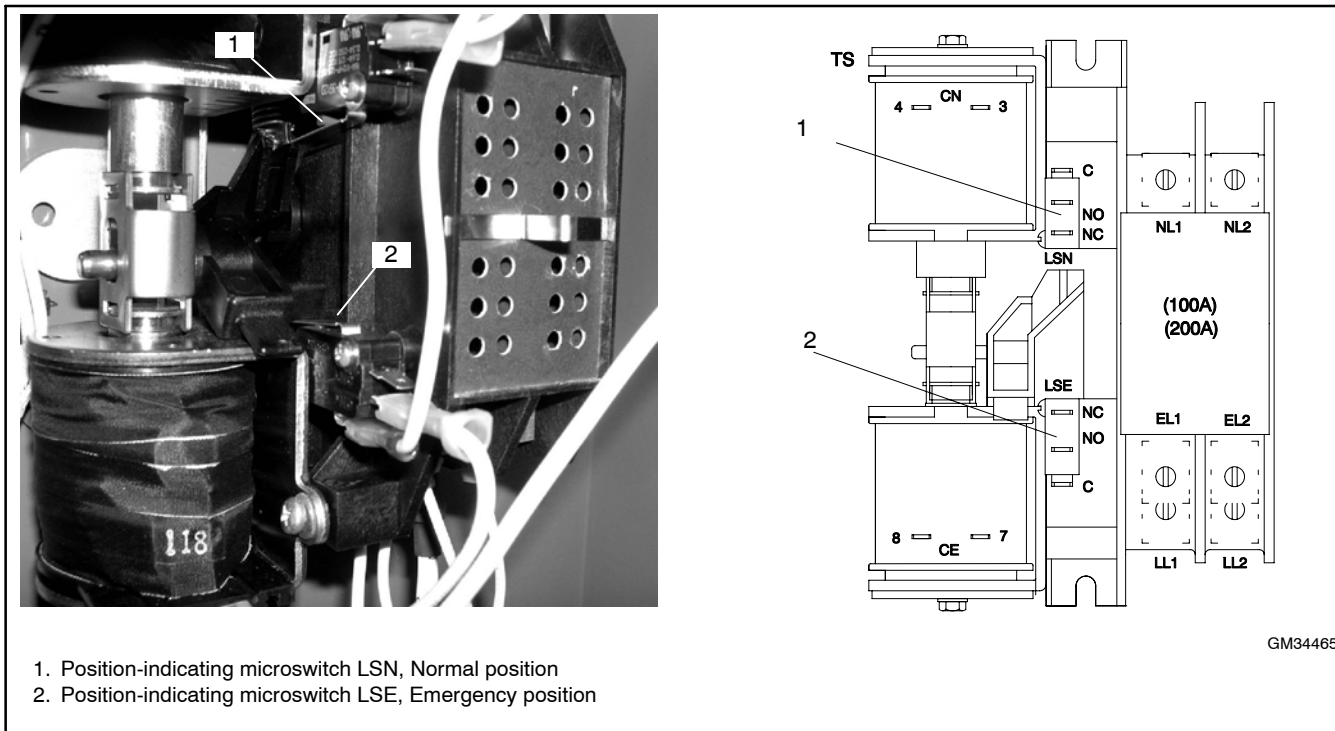

Figure 5-11 Position-Indicating Microswitches, 100/200-Amp Models

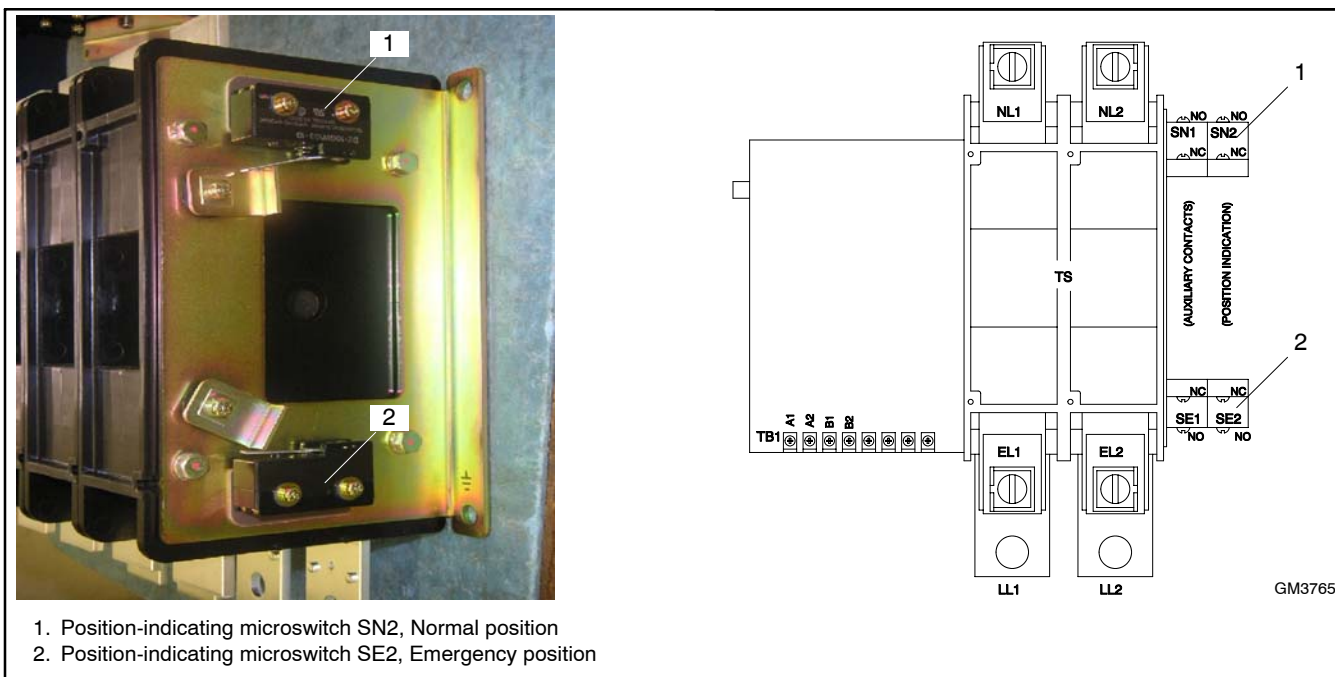

Figure 5-12 Position-Indicating Microswitches, 400-Amp Models

5.10 Solenoid Coil Testing

Check the voltage to the solenoid coil and test the control switch operation (400 amp units only) if there are signs of coil overheating or binding of the mechanism.

Note: The coils are energized for approximately 0.5 second to initiate transfer. Checking the voltage to the coils requires an analog voltmeter or a fast (250 microseconds min/max) digital multimeter with a peak (maximum) recording feature.

Voltage to the Coil Test Procedure 100/200 Amp Switches

See Figure 5-15 and Figure 5-16.

1. Disconnect leads CE and EL2(CE2) to the emergency source (lower) coil.
2. Set the multimeter to store the peak voltage. Connect the voltmeter across leads CE and EL2 (CE2) to test the voltage to the Emergency (lower) coil. Verify that there is no voltage across CE and EL2 at this time.
3. With the transfer switch in the normal position, press and hold the Test button for six seconds to start a loaded test. The generator set will start.
4. Use the multimeter's peak store feature to verify that 120 volts are applied to leads CE and EL2 as the controller attempts to transfer to the Emergency source. During normal operation, the coils are energized for approximately 0.5 second to initiate transfer. Check that the voltage is not applied for more than one second at a time.
5. The unit should attempt to transfer 3 times before indicating a failure to transfer fault. Press and hold both the Test and Exercise buttons simultaneously for 3 seconds to reset the fault.
6. Reconnect the leads to the Emergency source coil.
7. Disconnect leads CN and NL2 (CN2) to the Normal source (upper) solenoid coil.
8. Connect the voltmeter across leads CN and NL2 (CN2) to test the voltage to the Normal (upper) coil.
9. Press and hold the Test button for 6 seconds to initiate a loaded test. Wait for the mechanism to transfer.
10. Press the Test button for 2 seconds to stop the test. Use the multimeter's peak store feature to verify that 120 volts are applied to leads CN and NL2 as the controller attempts to transfer back to the normal source.

11. After testing, disconnect both sources and manually operate the switch to the Normal position. Reconnect the coil leads. Secure the ATS enclosure door before reconnecting power.

Voltage to the Coil Test Procedure 400 Amp Switches

See Figure 5-17 and Figure 5-18.

1. Remove the cover from the electronic section of the contactor assembly and disconnect the brown and gray coil leads. See Figure 5-13.
2. Set the multimeter to store the peak voltage. Connect the voltmeter across the brown and gray coil leads to test the voltage to the solenoid coil. Verify that there is no voltage across the coil leads at this time.
3. With the transfer switch in the normal position, press and hold the Test button for six seconds to start a loaded test. The generator set will start.
4. Use the multimeter's peak store feature to verify that 120 volts are applied to across the coil leads as the controller attempts to transfer to the emergency source. During normal operation, the coils are energized for approximately 0.5 second to initiate transfer. Check that the voltage is not applied for more than one second at a time.

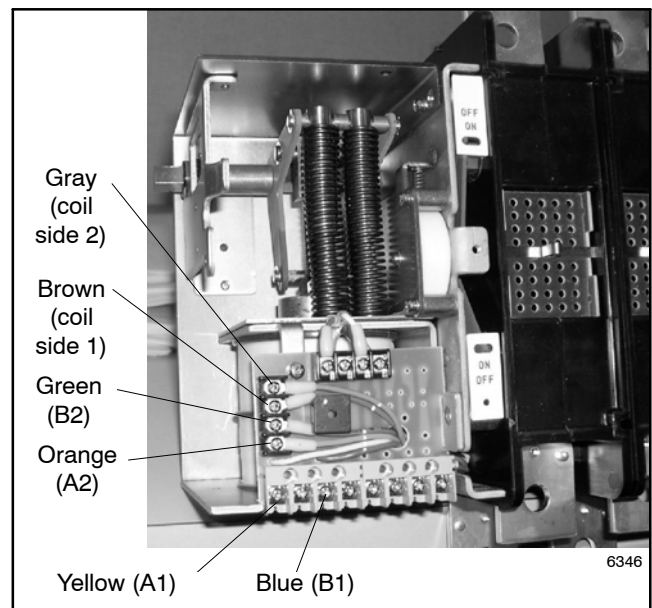

Figure 5-13 400 Amp Contactor Assembly, Cover Removed

5. The unit should attempt to transfer 3 times before indicating a failure to transfer fault. Press and hold both the Test and Exercise buttons simultaneously for 3 seconds to reset the fault.
6. Disconnect both sources to the transfer switch. Manually operate the switch to the emergency position.
7. Reconnect the emergency source.
8. With the voltmeter connected to the brown and gray coil leads, reconnect the normal source. Verify that 120 volts is applied across the coil leads as the ATS attempts to transfer to the normal source after the retransfer time delay. During normal operation, the coils are energized for approximately 0.5 second to initiate transfer. Check that the voltage is not applied for more than one second at a time.
9. The unit should attempt to transfer 3 times before indicating a failure to transfer fault. Press and hold both the Test and Exercise buttons simultaneously for 3 seconds to reset the fault.
10. If testing shows that 120 volts is not being applied to the coils, proceed to Section 5.10.1 to test the operation of the coil-operation control switches.
11. After testing, disconnect both sources and manually operate the switch to the normal position. Reconnect the coil leads to the terminals shown in Figure 5-13. Replace the cover on the electronic section of the contactor assembly. Secure the ATS enclosure door before reconnecting power.

5.10.1 Coil-Operation Control Switches (400 amp transfer switches)

Coil-operation control switches are used on 400 amp models only. See Figure 5-17 and Figure 5-18 for contact operation diagrams.

Contacts AX1 and AX2 are closed when the transfer switch is in the Emergency position. If the Normal source becomes available, K4 closes briefly to energize the coil, initiating transfer to the Normal position. Contacts AX1 and AX2 open during transfer.

Contacts BX1 and BX2 are closed when the transfer switch is in the Normal position. If the controller signals

for transfer to the emergency source, K5 closes briefly. If the Emergency source is available, the coil is energized and the ATS transfers to the Emergency position. Contacts BX1 and BX2 open during transfer.

Use an ohmmeter and the following procedure to test the operation of the control switches.

Coil-Operation Control Switch Test Procedure

1. Disconnect both sources to the transfer switch.
2. Remove the cover from the electronic section of the contactor assembly. See Figure 5-13.
3. With the transfer switch in the normal position, check across the terminals shown in Figure 5-14. Verify that contacts AX1 and AX2 are open, and contacts BX1 and BX2 are closed.
4. Manually operate the transfer switch to the emergency position.

Note: Do not manually operate the transfer switch with the power connected.
5. With the transfer switch in the emergency position, check across the terminals shown in Figure 5-14. Verify that contacts AX1 and AX2 are closed, and contacts BX1 and BX2 are open.

If a control switch does not operate as required, check the connections before replacing the switch. See Section 7.6 for instructions to separate the electronic and mechanical sections of the contactor assembly. See Figure 7-26 for the control switch location. Before disconnecting the switch leads, see Figure 5-13 and note the lead colors for reconnection of the new switch.

Terminals or Lead Colors	Switch	Switch State when Contactor is in:	
		Normal Position	Emergency Position
A1 (yellow) and Brown	AX1	Open	Closed
Orange (A2) and Gray	AX2	Open	Closed
B1 (blue) and Brown	BX1	Closed	Open
Green (B2) and Gray	BX2	Closed	Open

Figure 5-14 Coil-Operation Control Switches

5.10.2 Operating Sequence Diagrams

In the following figures, the current path is highlighted. Also note the open and closed contacts in each case.

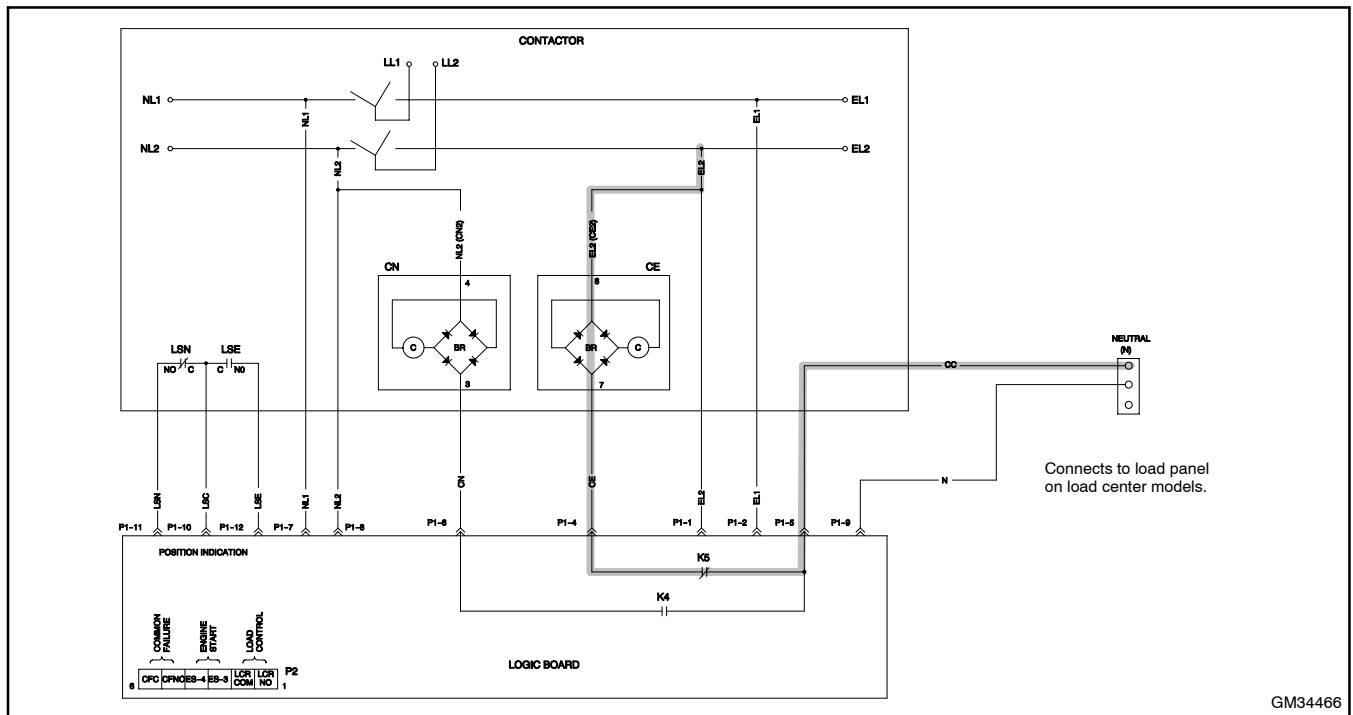

GM34466

Figure 5-15 Normal to Emergency, 100/200 Amps. Transfer Switch in the Normal Position, Normal Source Not Available, Emergency Available. After the Normal-to-Emergency Time Delay, the ATS Transfers to the Emergency Position.

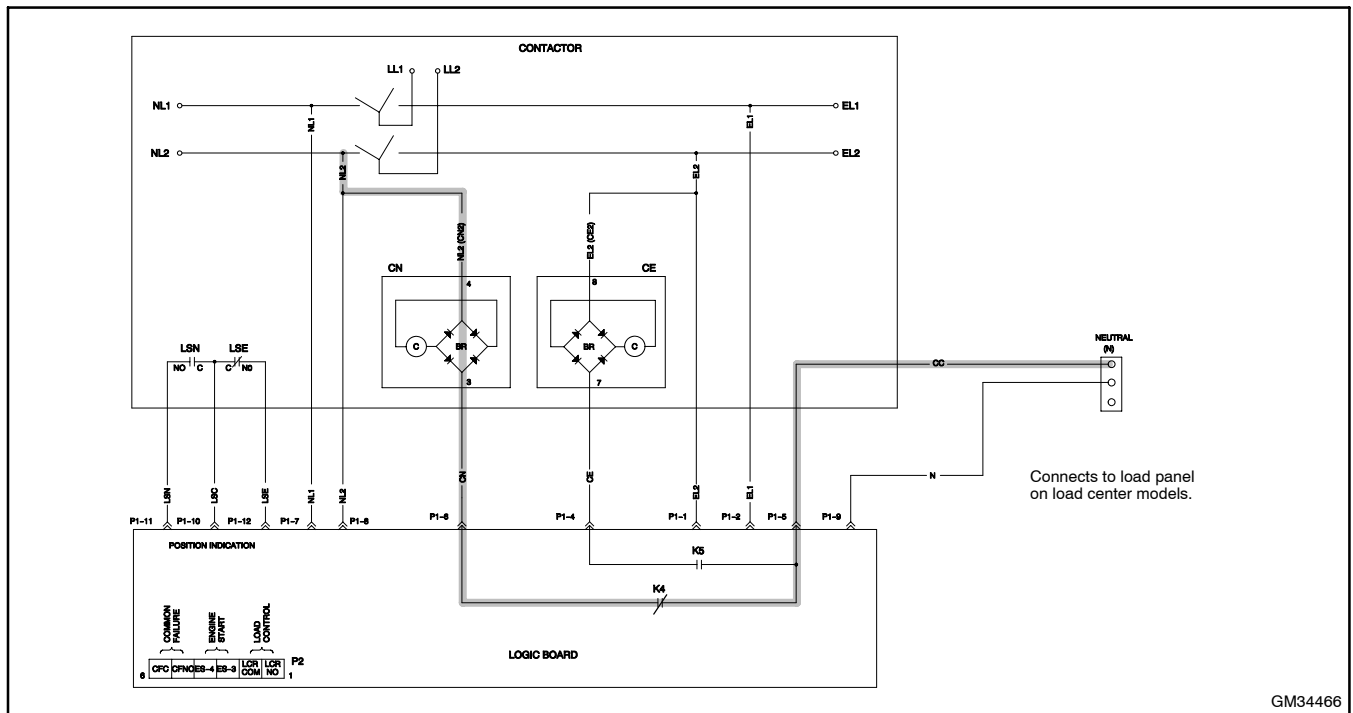

GM34466

Figure 5-16 Emergency to Normal, 100/200 Amp Models. Transfer Switch in the Emergency Position, Emergency Present, Normal Returns. After the Emergency-to-Normal Time Delay, the ATS Transfers to the Normal Position

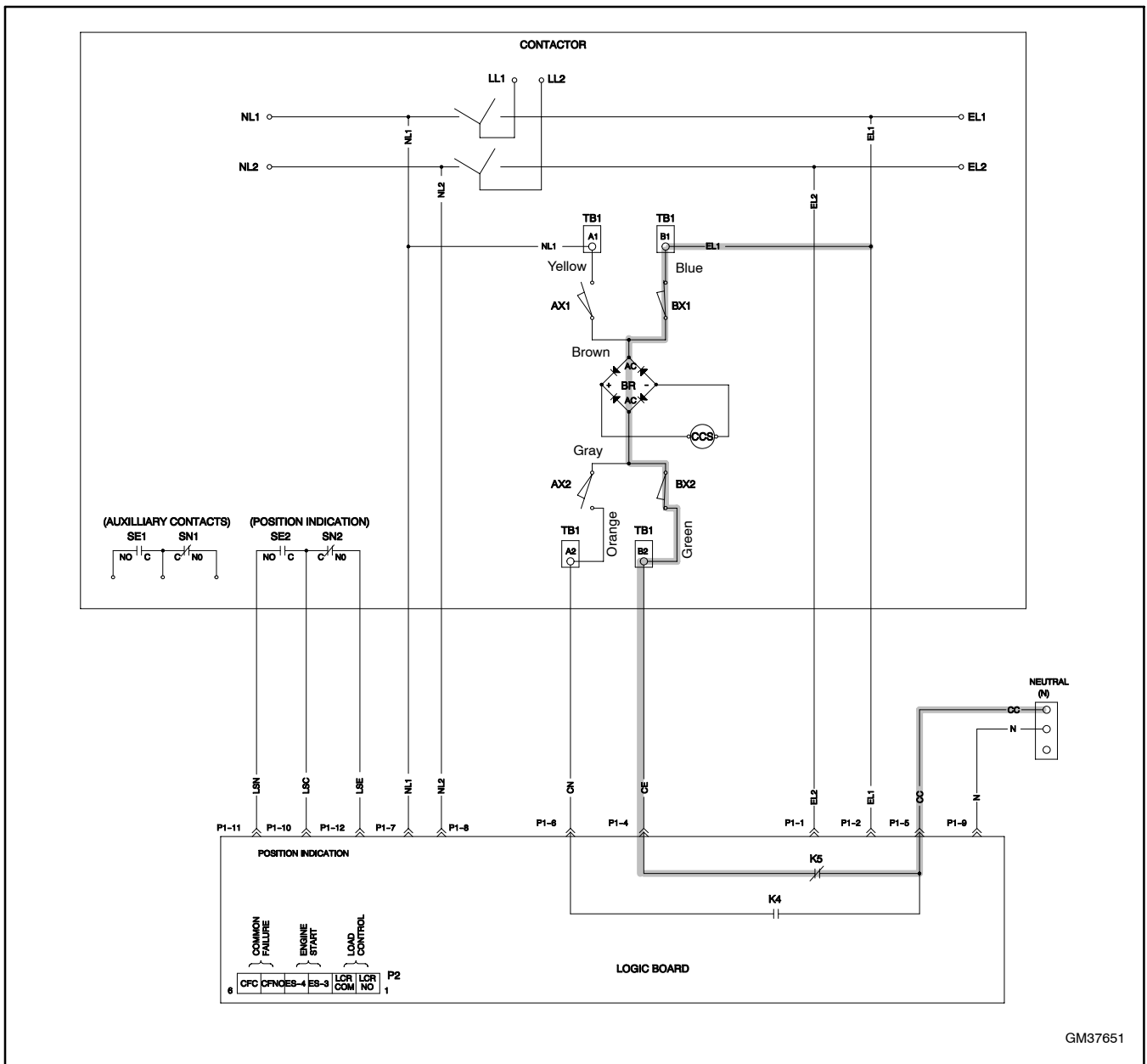

GM37651

Figure 5-17 Normal to Emergency, 400 Amp Models. Transfer Switch in the Normal Position, Normal Fails, Emergency Available. After the Normal-to-Emergency Time Delay, the ATS Transfers to the Emergency Position

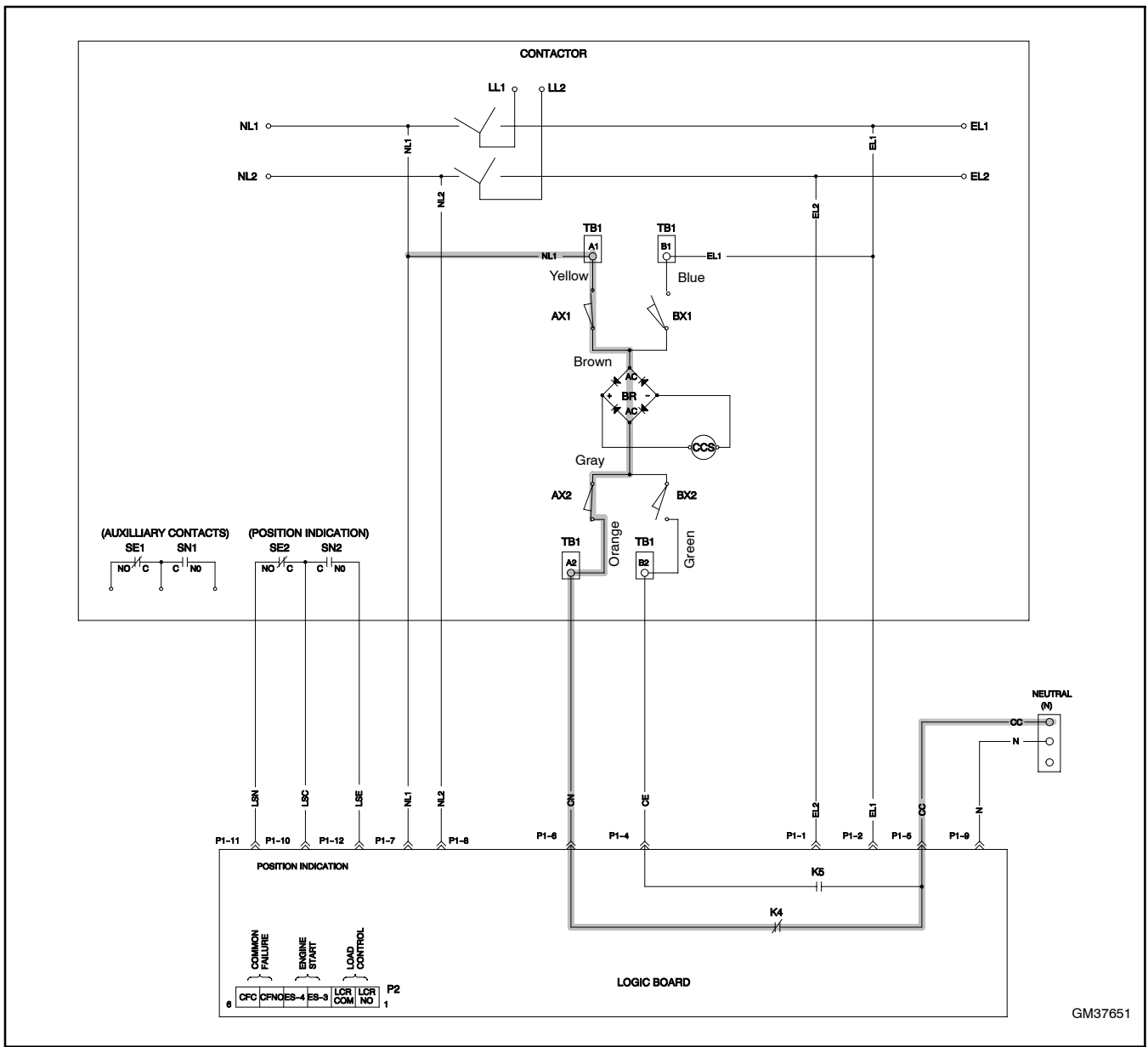

Figure 5-18 Emergency to Normal, 400 Amp Models. Transfer Switch in the Emergency Position, Emergency Present, Normal Returns, ATS Transfers to the Normal Position

5.11 Accessory Board

Check the following items on the optional Accessory Board.

- Check the 4-pin connector between the ATS controller circuit breaker and the accessory board.
- Check the timer switch and DIP switch settings on the accessory board. See Figure 5-19 and refer to the Transfer Switch Operation/Installation Manual, TP-6345, for instructions.
- Check that the timer switches are not set between two values. Use a small screwdriver and feel for a small click when the switch moves into position.
- Disconnect any remote input/output connections to the accessory board and run a test sequence to rule out problems with customer equipment connected to the board. See Section 2.3.

If the checks above do not identify the problem, remove the accessory board and check the transfer switch operation without it.

Removing the Accessory Board

1. Move the generator set master switch to the OFF position.
2. Disconnect power to the transfer switch by opening both source circuit breakers or switches.
3. Open the transfer switch enclosure door.
4. The accessory board is mounted on stand-offs on top of the main logic board. See Figure 5-20. Disconnect any connections to P9 and P13 on the accessory board.
5. Notice the small 4-pin connector between the two circuit boards. Remove the accessory board by pulling it straight off the main logic board. Remove the small 4-pin connector.

6. Close the enclosure door and reconnect power. Move the generator set master switch to AUTO. The generator set may start and run until the engine cooldown time delay expires.

7. Run a test sequence to check that the transfer switch operates with the factory-default settings for a transfer switch without an optional accessory board. See Section 2.3.

If the transfer switch operates as expected without the accessory board, but not when the accessory board is installed, the problem lies in the accessory board. Check the items at the beginning of this section before replacing the accessory board.

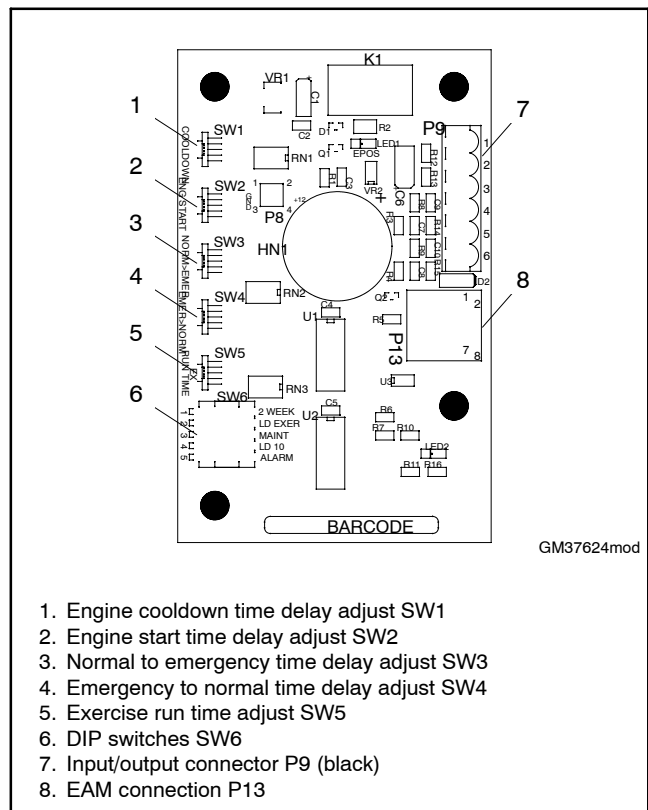

Figure 5-19 Accessory Board Component Locations

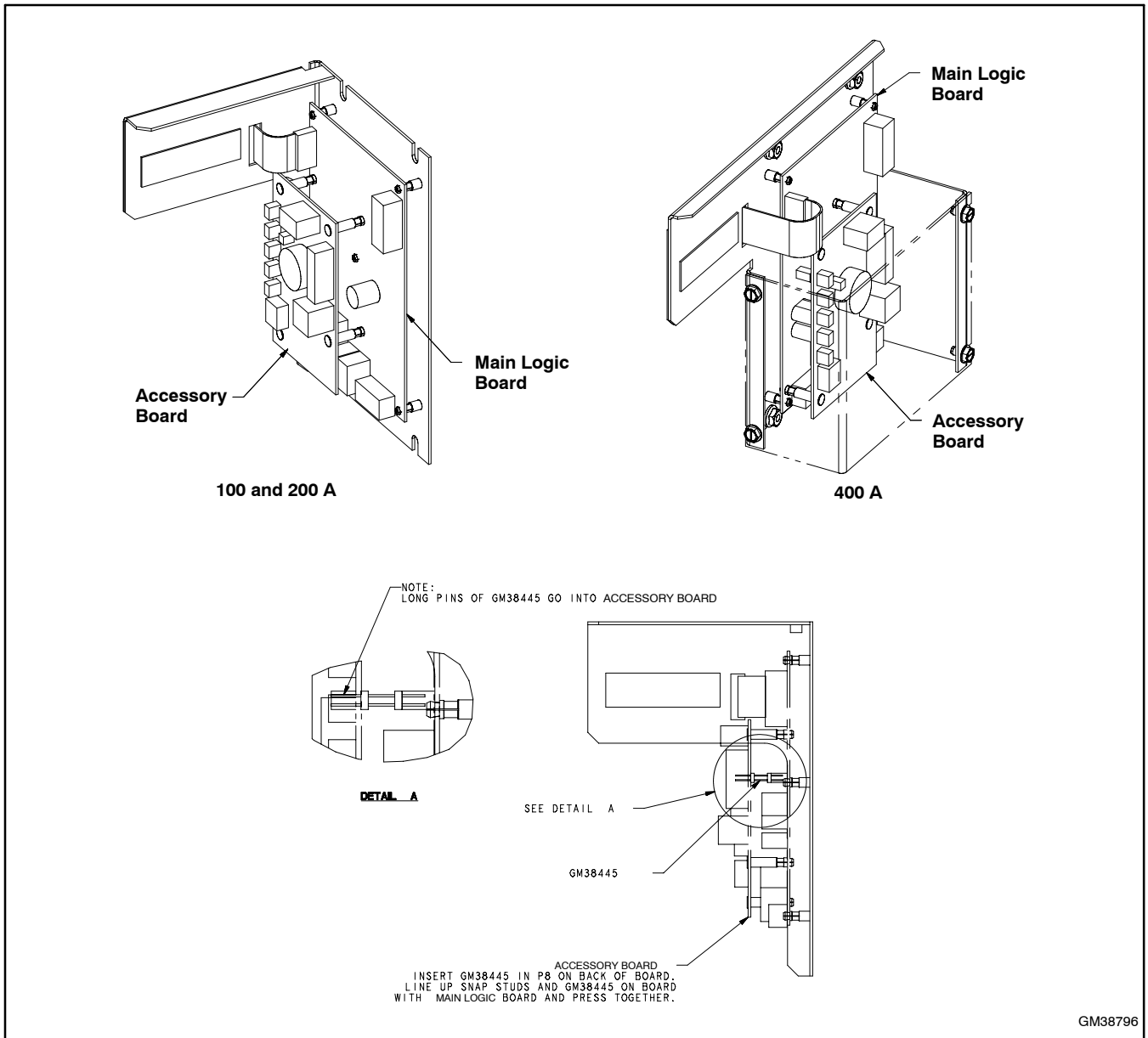

Figure 5-20 Accessory Board Location

5.12 External Alarm Module (EAM)

Check the following items if the optional External Alarm Module (EAM) does not operate as expected. See Figure 5-21. Figure 5-22 summarizes the LED and alarm indication. Refer to TT-1416 for EAM operation instructions.

- Check the Category 5e cable connections to the EAM module and the ATS Accessory Board.
- Check the power and ground connections.
- Do a lamp test on the EAM: press the Alarm Silence button *briefly* (less than 1 second) to illuminate both LEDs.
- Be sure to hold the Test button at least 1 second to start or stop a test. Listen for an audible click when the relay on the EAM circuit board operates.
- Check for faults. See TT-1416. Identify and correct the cause of the fault condition and then clear the fault on the EAM.
- For problems retransferring the load to the Utility source, check that the utility source available LED on the transfer switch is lit. The EAM will not transfer the load if utility power is not available.
- Verify that the maintained/momentary DIP switch on the accessory board (switch number 3) is in the ON (maintained) position.
- Check the accessory board connection to the controller circuit board.

- Troubleshoot the accessory board. See Section 5.11.
- Verify that one source is available to power the EAM.
- Check the Alarm Silence button. If the alarm was silenced when the GEN LED was not illuminated, there is no visible indication that the alarm has been silenced.

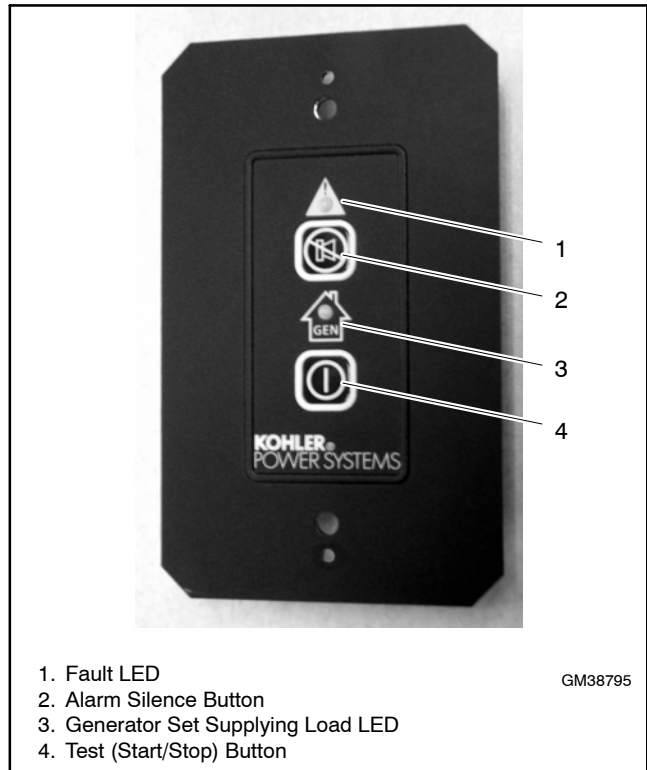

Figure 5-21 External Alarm Module (EAM)

LED Indicator		Alarm	Condition
GEN	Steady	One beep/10 minutes	Generator set supplying load after a remote start signal from the EAM Test button
	Fast flash every second	None	Generator set supplying load after a remote start signal from the EAM Test button and alarm silenced
		None	Generator set supplying load due to automatic start after utility power loss or exercise run
	Slow flash every 2 seconds	None	System starting or stopping in response to Test (Start/Stop) button
Fault	Steady	Three short beeps/minute	Power system (ATS) fault
	Flashing	Three short beeps/minute	Test did not start (or stop) within 2 minutes of EAM Test button activation

Figure 5-22 EAM LED and Alarm Indication

Section 6 Drawings and Diagrams

Diagram or Drawing	Drawing Number	Page
Schematic Diagrams		
100/200 Amp without Load Center	GM34466-D	65
100/200 Amp with Load Center	GM37649-D	66
400 Amp without Load Center	GM37651-D	68
Wiring Diagrams		
100/200 Amp without Load Center	GM34465-D	64
100/200 Amp with Load Center	GM37650-E	67
400 Amp without Load Center	GM37652-E	69
Programmable Exerciser (Optional)	GM39331-A	70

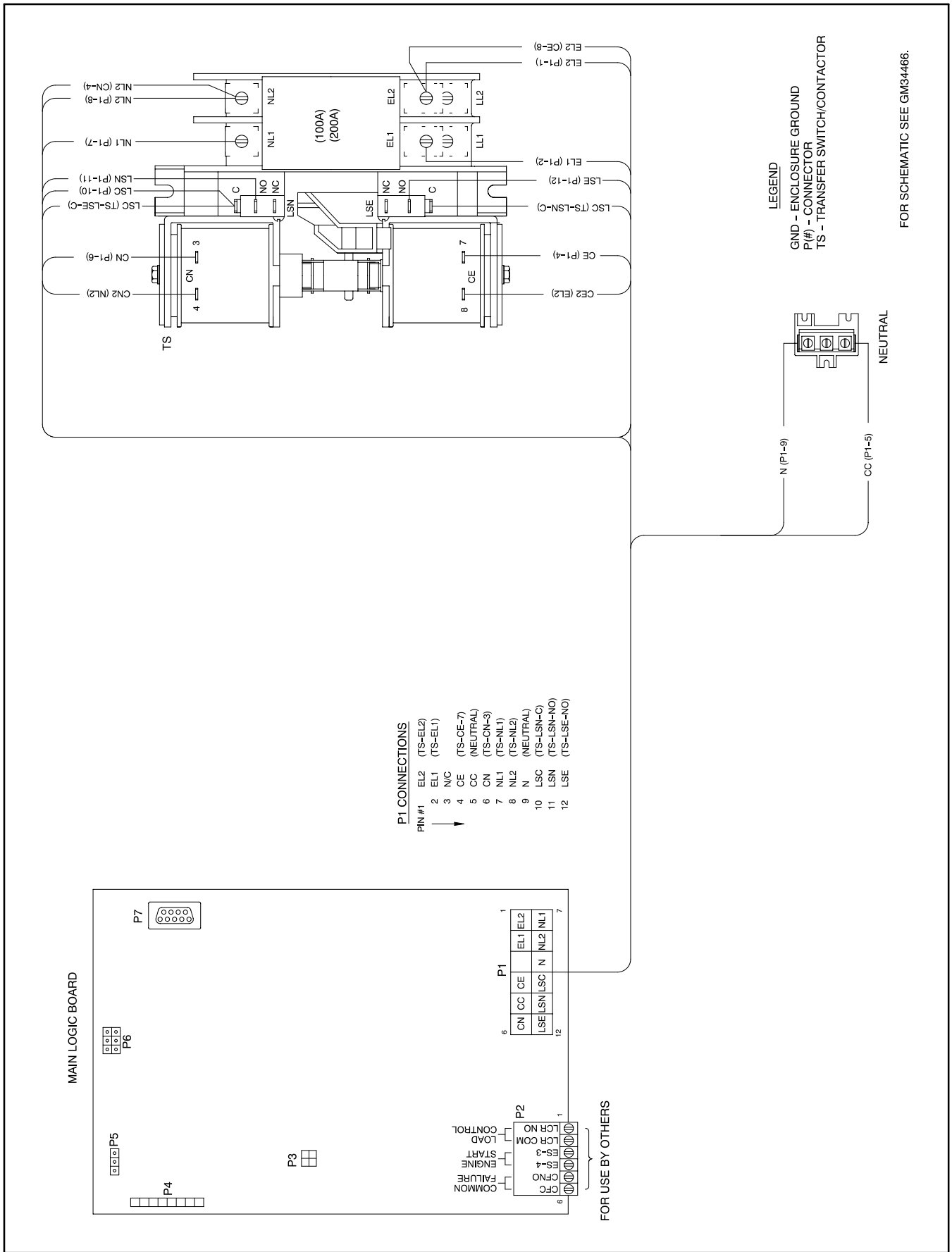

Figure 6-1 Wiring Diagram, 100/200 Amp without Load Center, GM34465-D

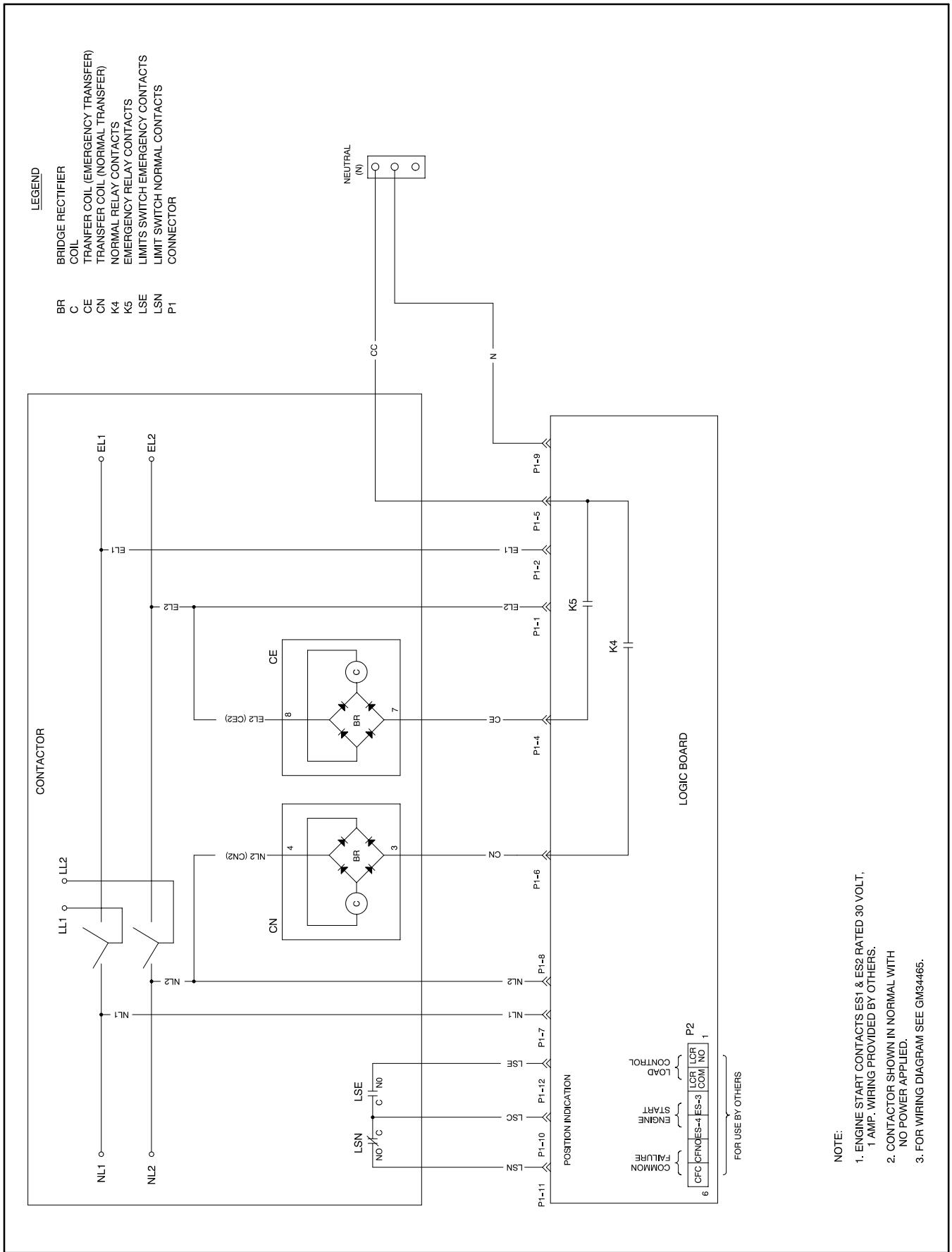

Figure 6-2 Schematic Diagram, 100/200 Amp without Load Center, GM34466-D

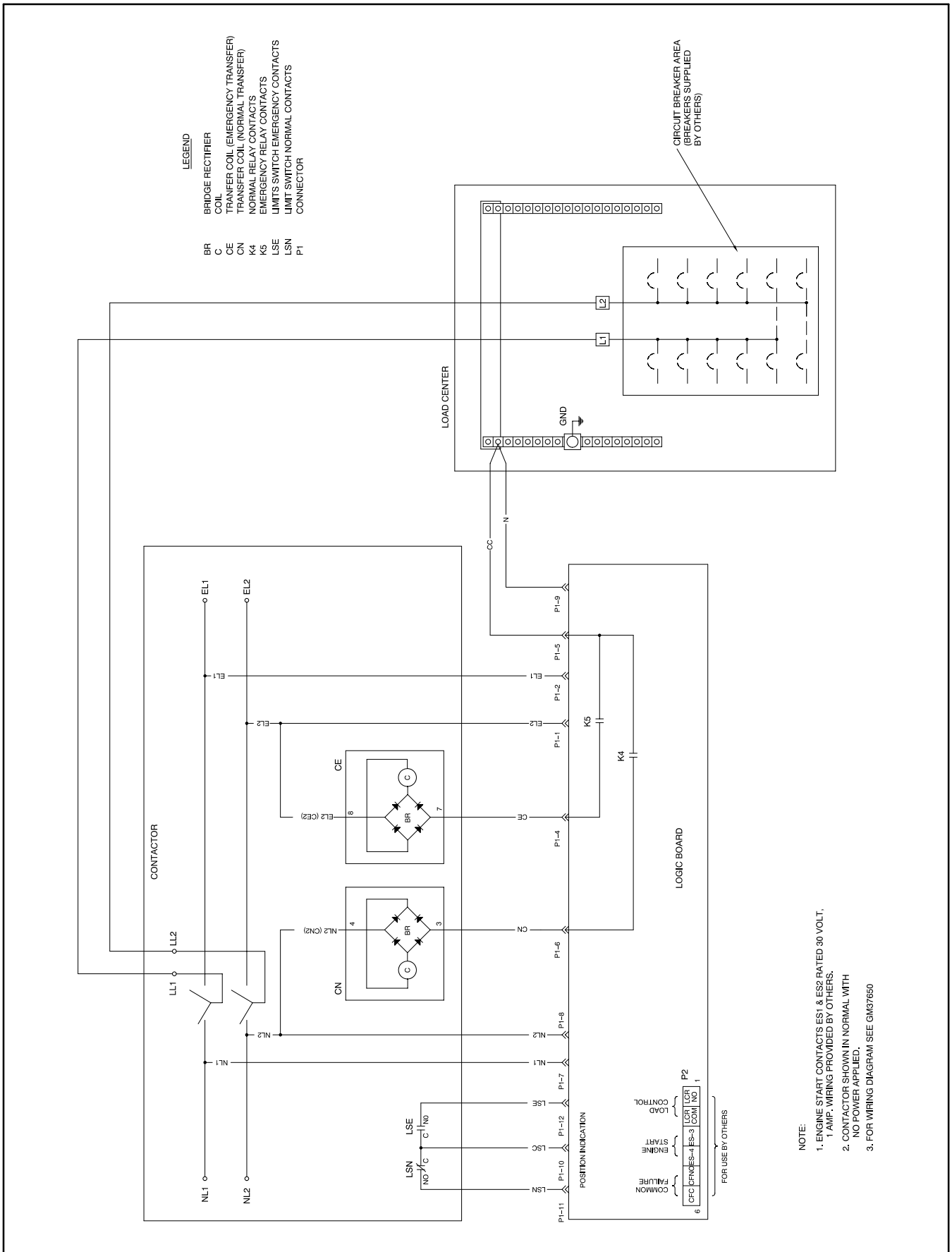

Figure 6-3 Schematic Diagram, 100/200 Amp with Load Center, GM37649-D

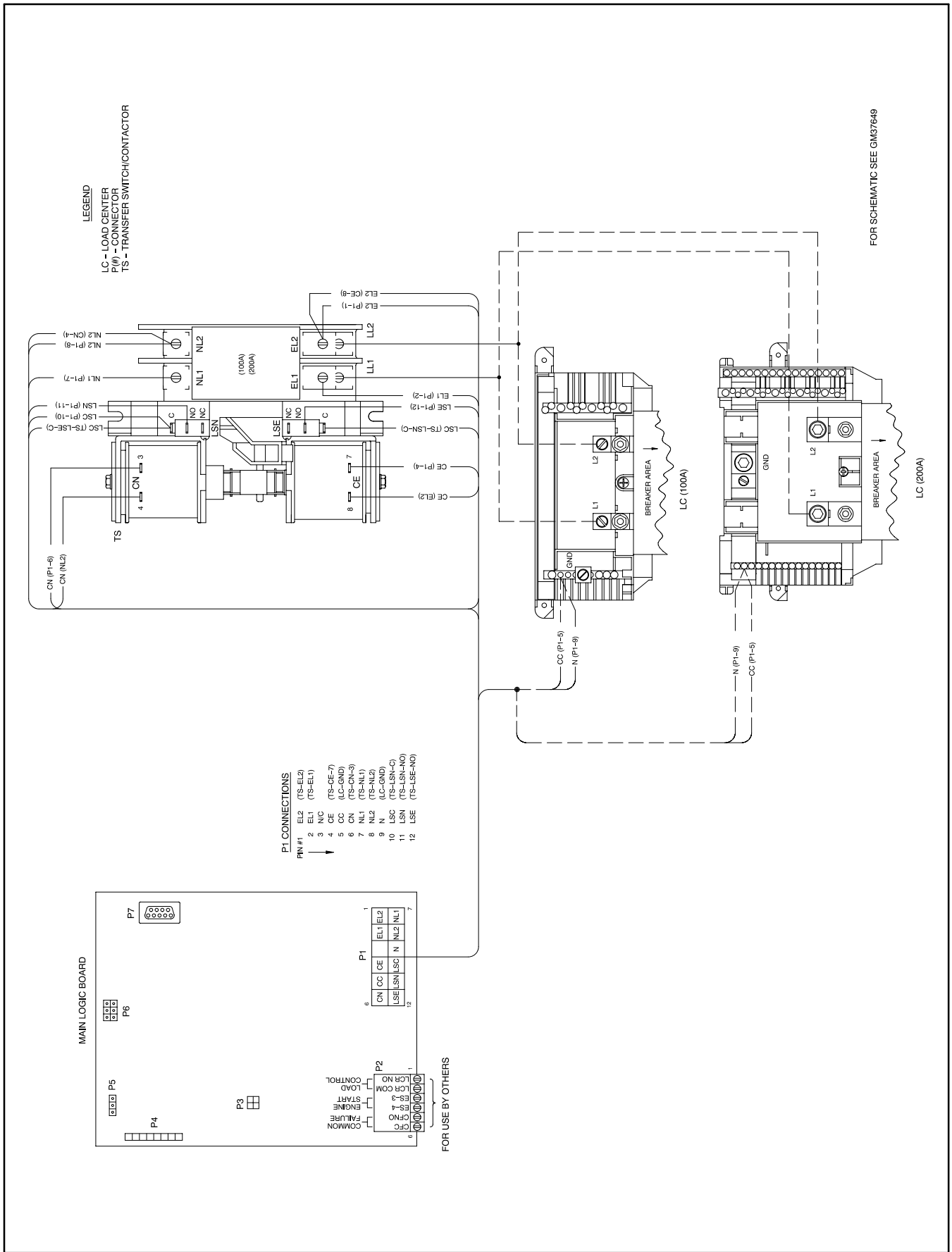

Figure 6-4 Wiring Diagram, 100/200 Amp with Load Center, GM37650-E

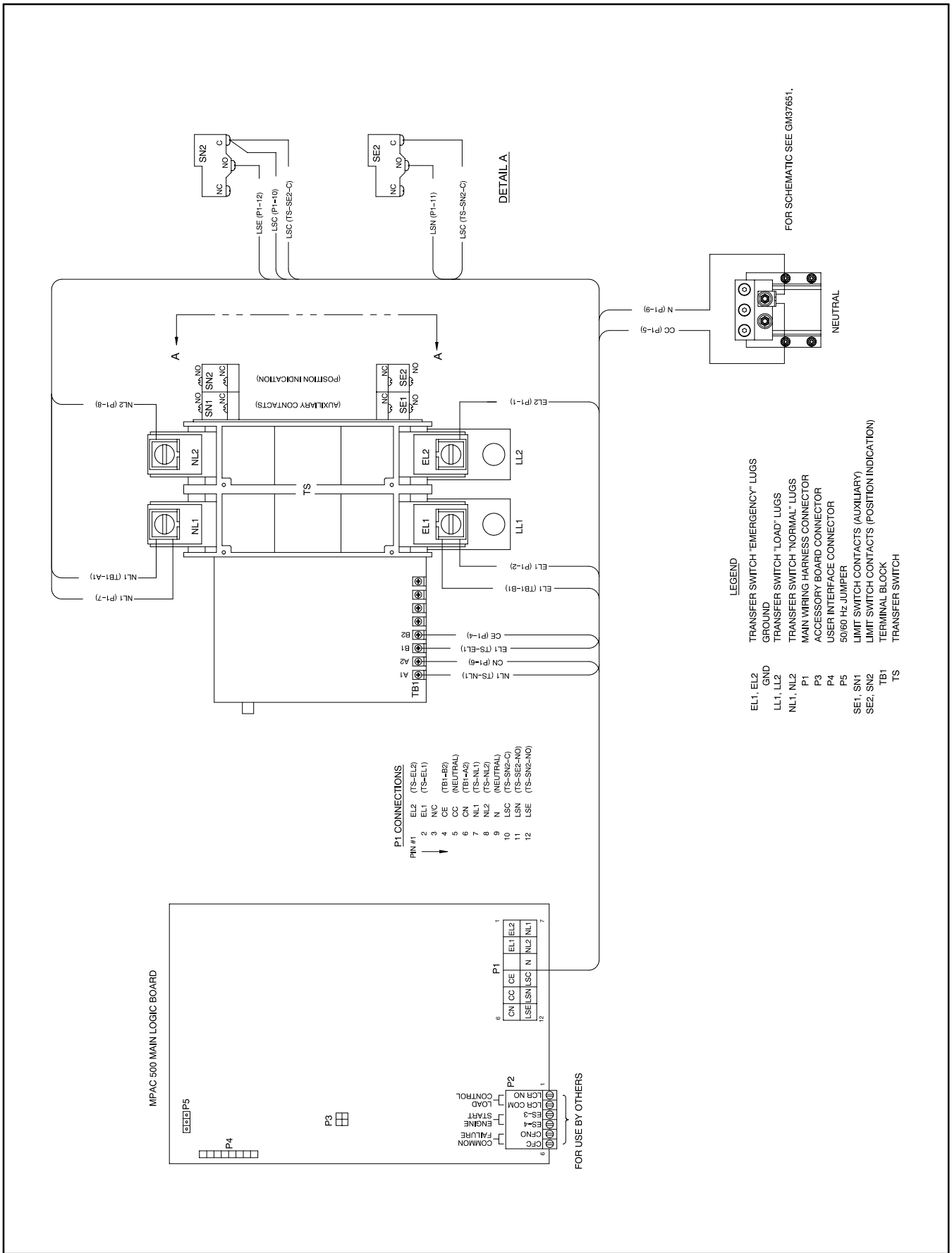
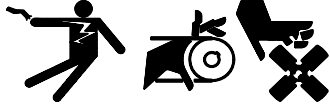

Figure 6-6 Wiring Diagram, 400 Amp, GM37652-E

Section 7 Service Part Replacement

Use the instructions in this section for transfer switch service part replacement. See Section 8 for service parts.

WARNING



Accidental starting. Can cause severe injury or death.

Disconnect the battery cables before working on the generator set. Remove the negative (-) lead first when disconnecting the battery. Reconnect the negative (-) lead last when reconnecting the battery.

Disabling the generator set. Accidental starting can cause severe injury or death. Before working on the generator set or connected equipment, disable the generator set as follows: (1) Move the generator set master switch to the OFF position. (2) Disconnect the power to the battery charger. (3) Remove the battery cables, negative (-) lead first. Reconnect the negative (-) lead last when reconnecting the battery. Follow these precautions to prevent starting of the generator set by an automatic transfer switch, remote start/stop switch, or engine start command from a remote computer.

DANGER



Hazardous voltage. Will cause severe injury or death.

Disconnect all power sources before opening the enclosure.

DANGER



Hazardous voltage. Will cause severe injury or death.

Only authorized personnel should open the enclosure.

Servicing the transfer switch. Hazardous voltage can cause severe injury or death. Deenergize all power sources before servicing. Open the main circuit breakers of all transfer switch power sources and disable all generator sets as follows: (1) Move all generator set master controller switches to the OFF position. (2) Disconnect power to all battery chargers. (3) Disconnect all battery cables, negative (-) leads first. Reconnect negative (-) leads last when reconnecting the battery cables after servicing. Follow these precautions to prevent the starting of generator sets by an automatic transfer switch, remote start/stop switch, or engine start command from a remote computer. Before servicing any components inside the enclosure: (1) Remove all jewelry. (2) Stand on a dry, approved electrically insulated mat. (3) Test circuits with a voltmeter to verify that they are deenergized.

Testing live electrical circuits. Hazardous voltage or current can cause severe injury or death. Have trained and qualified personnel take diagnostic measurements of live circuits. Use adequately rated test equipment with electrically insulated probes and follow the instructions of the test equipment manufacturer when performing voltage tests. Observe the following precautions when performing voltage tests: (1) Remove all jewelry. (2) Stand on a dry, approved electrically insulated mat. (3) Do not touch the enclosure or components inside the enclosure. (4) Be prepared for the system to operate automatically.
(600 volts and under)

Making line or auxiliary connections. Hazardous voltage can cause severe injury or death. To prevent electrical shock deenergize the normal power source before making any line or auxiliary connections.

Servicing the transfer switch controls and accessories within the enclosure. Hazardous voltage can cause severe injury or death. Disconnect the transfer switch controls at the inline connector to deenergize the circuit boards and logic circuitry but allow the transfer switch to continue to supply power to the load. Disconnect all power sources to accessories that are mounted within the enclosure but are not wired through the controls and deenergized by inline connector separation. Test circuits with a voltmeter to verify that they are deenergized before servicing.

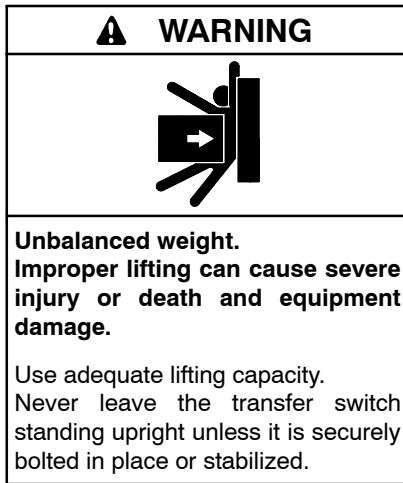

NOTICE

Electrostatic discharge damage. Electrostatic discharge (ESD) damages electronic circuit boards. Prevent electrostatic discharge damage by wearing an approved grounding wrist strap when handling electronic circuit boards or integrated circuits. An approved grounding wrist strap provides a high resistance (about 1 megohm), *not a direct short*, to ground.

NOTICE

Hardware damage. The transfer switch may use both American Standard and metric hardware. Use the correct size tools to prevent rounding of the bolt heads and nuts.

NOTICE

When replacing hardware, do not substitute with inferior grade hardware. Screws and nuts are available in different hardness ratings. To indicate hardness, American Standard hardware uses a series of markings, and metric hardware uses a numeric system. Check the markings on the bolt heads and nuts for identification.

7.1 Before and After Servicing Components

Before Service. Follow these instructions before opening the enclosure and servicing the transfer switch.

1. Prevent the emergency power source generator set from starting by placing the generator set

master switch in the OFF position; disconnecting power to the generator set battery charger, if installed; and removing the generator set engine start battery cables, negative (-) lead first.

2. Disconnect or turn off *both* the normal and emergency power sources before opening the enclosure door. Check circuits with a voltmeter to verify that the power is off before servicing components inside the enclosure.

After Service. After servicing the transfer switch, remove debris from the enclosure and reinstall barriers. Do not use compressed air to remove debris from the enclosure.

7.2 Circuit Board Handling

- Store circuit boards in the anti-static, cushioned packaging provided by the factory in a clean environment away from moisture, vibration, static electricity, corrosive chemicals, solvents, or fumes until installation.
- Wear an approved grounding, anti-static wrist strap when handling circuit boards or components.
- Carefully hold the circuit board only by its edges, not by any of its components.
- Don't bend or drop the circuit board or any of its components.
- Don't strike the circuit board or any of its components with a hard object.
- Clean dusty or dirty circuit boards only with a vacuum cleaner or dry brush.
- Never attempt component-level circuit repairs.
- Never remove or install a circuit board with power connected.
- Label wiring when disconnecting it for reconnection later.

7.3 Controller Circuit Board Replacement

The controller includes a printed circuit board and separate switch/LED membrane mounted on a bracket inside the ATS enclosure.

Replace the controller's printed circuit board only if the troubleshooting and test procedures in this manual indicate conclusively that the controller is damaged or inoperative. Check the following items before replacing the circuit board:

- Check for open source circuit breakers or switches.
- Check for loose connections and faulty wiring.
- Reset the controller and retest the operation. See Sections 4.4 and 2.3.
- Remove the Accessory Board, if equipped, and test the transfer switch operation without it. See Section 5.11.
- Check the neutral connection.

Disconnect power to the transfer switch before starting to disconnect the controller. Observe the following safety precautions to avoid injury or equipment damage.

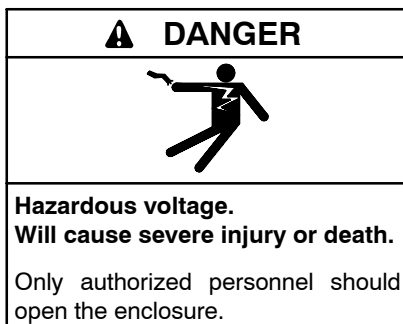
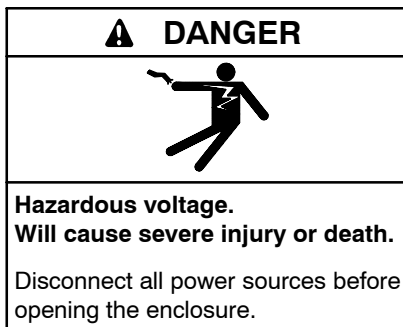

Servicing the transfer switch. Hazardous voltage can cause severe injury or death. Deenergize all power sources before servicing. Open the main circuit breakers of all transfer switch power sources and disable all generator sets as follows: (1) Move all generator set master controller switches to the OFF position. (2) Disconnect power to all battery chargers. (3) Disconnect all battery cables, negative (-) leads first. Reconnect negative (-) leads last when reconnecting the battery cables after servicing. Follow these precautions to prevent the starting of generator sets by an automatic transfer switch, remote start/stop switch, or engine start command from a remote computer. Before servicing any components inside the enclosure: (1) Remove all jewelry. (2) Stand on a dry, approved electrically insulated mat. (3) Test circuits with a voltmeter to verify that they are deenergized.

Electronic printed circuit boards (PCBs) are sensitive to a variety of elements and can be damaged during removal, installation, transportation, or storage. Observe the following when working with circuit boards.

Controller Circuit Board Replacement Procedure

1. Move the generator set master switch to the OFF position.
2. Disconnect the generator set engine starting battery, negative (-) lead first.
3. Disconnect power to the transfer switch by opening switches or circuit breakers to the switch. Wait at least 25 minutes to allow the power supply to discharge completely.
4. Open the transfer switch enclosure.
5. Check the voltage at the source connections to verify that the power is off.
6. 400 amp models only: Remove four screws and remove the guard from the controller assembly. See Figure 7-1.
7. Models equipped with the optional Accessory Board (see Figure 7-1):
 - a. Disconnect the 6-pin input/output connector at P9. Label the plug, if necessary, to distinguish it from the 6-pin plug to the controller circuit board.
 - b. Disconnect the RJ45 connector to the External Alarm Module, if equipped.
 - c. Remove the accessory board by pulling it straight off the main logic board. Remove the small 4-pin connector between the two circuit boards.

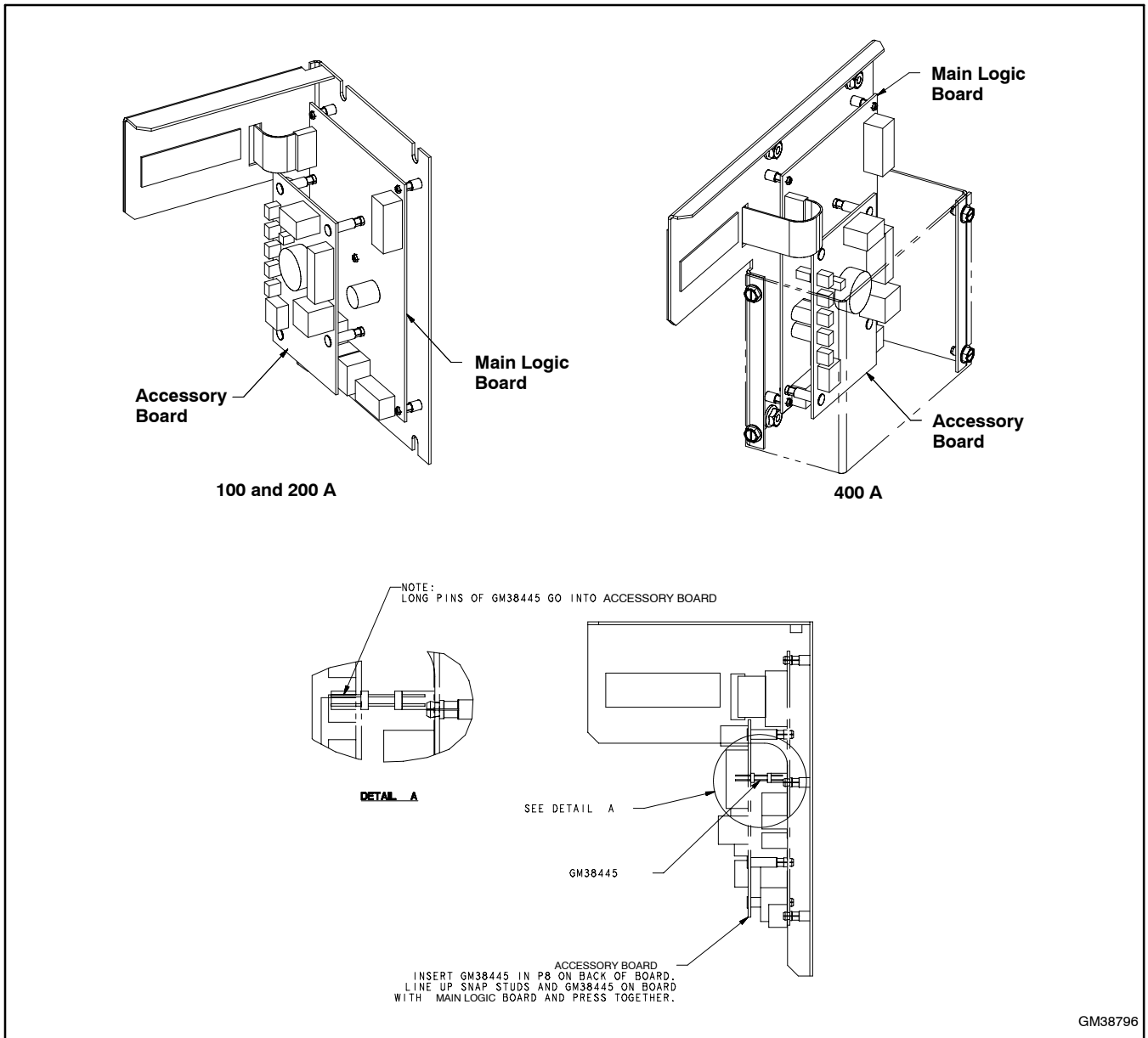

Figure 7-1 Controller Assembly with Accessory Board

8. Disconnect all connections to the controller circuit board. See Figure 7-2.
 - a. Disconnect the transfer switch harness at the P1 connector on the bottom of the controller circuit board.
 - b. Disconnect the customer connections at P2. Label the connector, if necessary, to distinguish it from the accessory board input/output connector.
 - c. Disconnect the ribbon cable to the switch/LED membrane at P4.
 - d. Disconnect the serial cable from port P7, if connected.
9. The circuit board is mounted onto the bracket with five standoffs. Carefully pull the circuit board off the standoffs.
10. Place the new circuit board on the bracket with the mounting holes aligned with the standoffs and the P1 and P2 connectors at the bottom. Push firmly until all four corners and the center snap into place.
11. Reconnect all connectors removed in step 8.
12. Reinstall the Accessory Board, if equipped. See Figure 7-1.
 - a. Insert the 4-pin connector through the back of the accessory board into P8 with the longer pins inserted into the accessory board. See Figure 5-20.
 - b. Place the accessory board over the controller circuit board and align the 4-pin connector with P3. Align the 4 standoffs with the mounting holes in the controller circuit board. Press firmly until all four standoffs snap into place.
 - c. Reconnect all connectors removed in step 7.
13. 400 amp models: Replace the controller guard and secure with 4 screws.
14. Replace the ATS enclosure door.
15. Reconnect power to the ATS.
16. Reconnect the generator set engine starting battery, negative (-) lead last.
17. Move the generator set master switch to AUTO.
18. Check the transfer switch operation by running an Automatic Operation Test. See Section 2.3.
19. Set the exerciser. See Section 2.4.

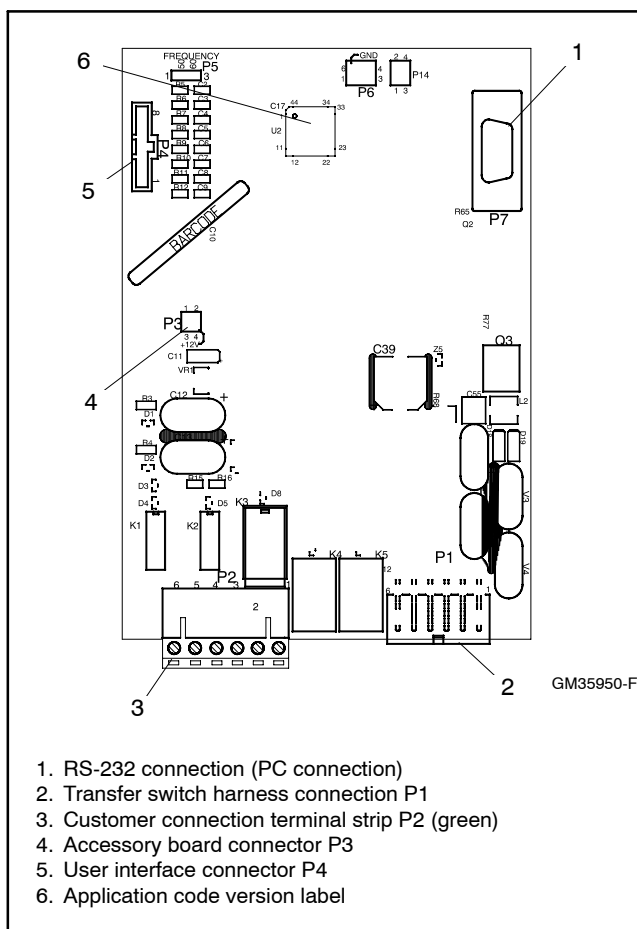

Figure 7-2 Control Board Connectors

7.4 Contactor Assembly Removal and Installation

Use the instructions in this section if it is necessary to remove the entire contactor assembly from the enclosure.

Note: Serviceable contactor assembly parts can be replaced without removing the contactor assembly from the enclosure.

7.4.1 Contactor Assembly Removal

1. Disable the generator set and disconnect all power sources as described in Section 7.1 before opening the transfer switch enclosure.
2. Loosen the power terminal lugs and disconnect the normal, emergency, and load power conductors, and label and tape the ends of the conductors.
3. Disconnect the contactor wiring harness from the controller at connector P1.
4. Support the contactor and remove the screws located at the corners of the contactor's base that secure the contactor assembly to the back wall of the enclosure. See Figure 7-3 or Figure 7-4.

Note: Some earlier 100 and 200 Amp units used only three mounting screws.

5. Lift and pull the contactor assembly from the enclosure.

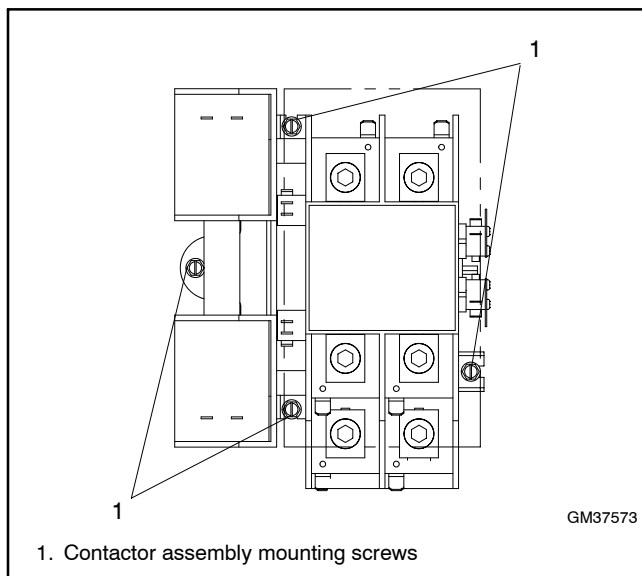

Figure 7-3 Contactor Mounting Screws, 100/200 Amp Models, Typical

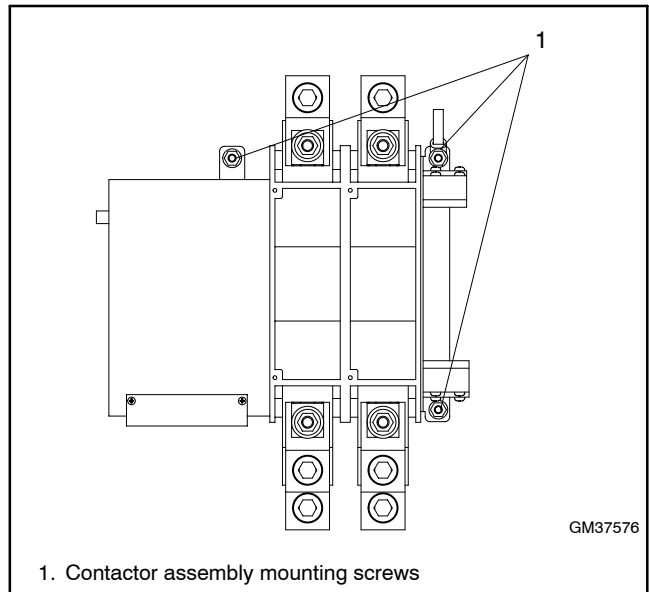

Figure 7-4 Contactor Mounting Screws, 400 Amp Models

7.4.2 Contactor Assembly Installation

1. Align the contactor assembly mounting holes with the mounting holes in the transfer switch enclosure.
2. Reinstall the screws that secure the contactor assembly. Tighten the screws to the torques shown in Figure 7-5.

Model	Torque, in. lbs.
100 Amp	26
200 Amp	26
400 Amp	32

Figure 7-5 Tightening Torques, Contactor Mounting Screws

3. Reconnect the power source and load conductors to the lugs. Tighten the connections to the torques shown in Section 3.2.2 of this manual.
4. Reconnect the contactor wiring harness to the controller at connector P1.

7.5 100-200 Amp Model Service

7.5.1 Solenoid Assembly

Disable the generator set and disconnect all power sources as described in Section 7.1 before opening the transfer switch enclosure.

Procedures shown are for the Normal source coil. Use the same procedures for the Emergency source coil. Perform the coil replacement procedures on one source side at a time.

- To replace the Normal source coil, first move the contactor to the Emergency source position.
- To replace the Emergency source coil, first move the contactor to the Normal source position.

Solenoid Assembly Removal

Remove the solenoid assembly from the current-carrying unit by removing two mounting screws from the assembly. See Figure 7-6.

Note: Two square nuts will be released when the mounting screws are removed. Save the screws and nuts for reinstallation later.

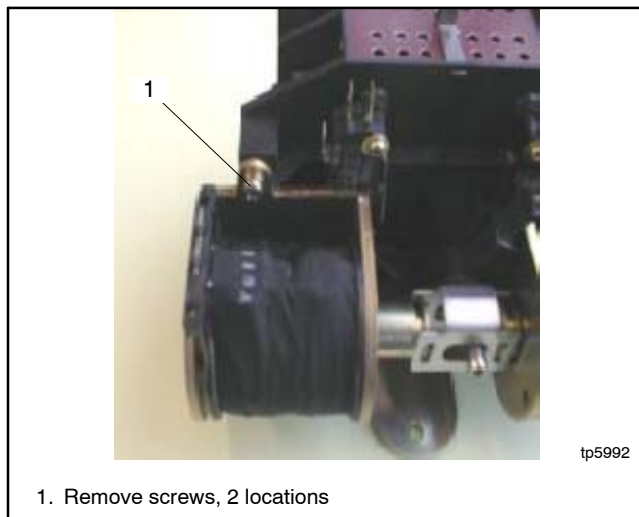

Figure 7-6 Solenoid Assembly

Solenoid Disassembly

1. Remove two screws from the core plate. See Figure 7-7.
2. Remove the core plate and the steel core with washer. See Figure 7-8.
3. Remove the coil from the coil bracket. See Figure 7-8.



Figure 7-7 Disassembling the Coil Assembly

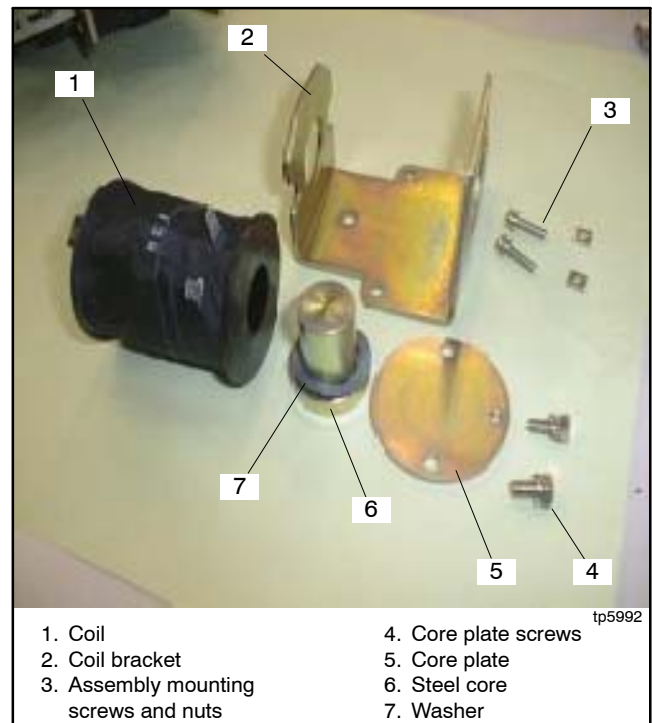

Figure 7-8 Coil Assembly Parts

Solenoid Reassembly

1. Position the coil in the bracket with the tab on the top of the coil and operating circuit terminal oriented as shown in Figure 7-9 for the Normal source coil or in Figure 7-10 for the Emergency source coil.
2. Insert the steel core with washer into the coil. See Figure 7-9.
3. Install the core plate and tighten the two core plate screws. See Figure 7-7.

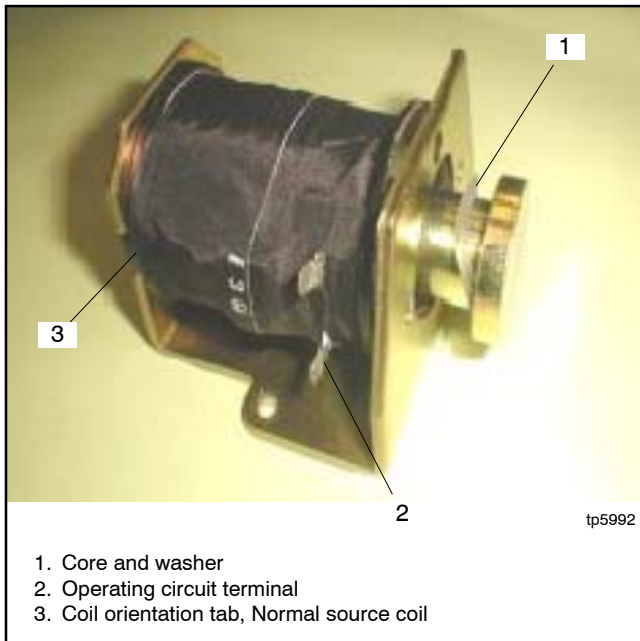

Figure 7-9 Coil Assembly, Normal Source Coil Shown (note the coil orientation)

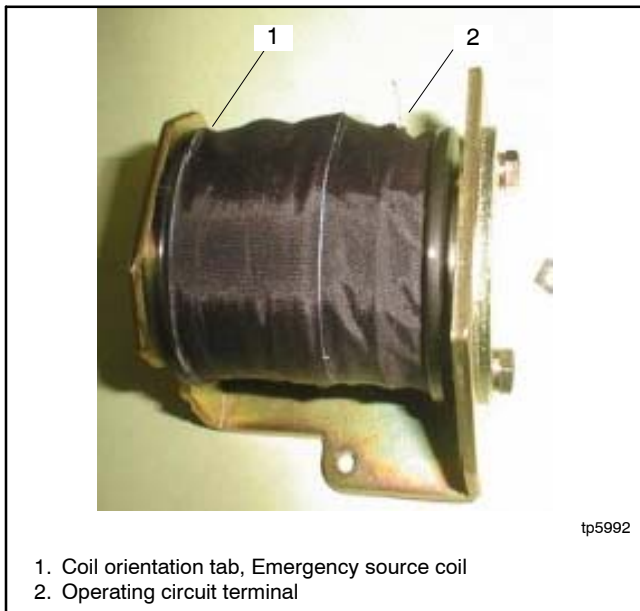

Figure 7-10 Emergency Source Coil Assembly (note the coil orientation)

7.5.2 Solenoid Assembly Installation

1. Insert the two square nuts into the grooves on the frame. See Figure 7-11.
2. Align locating hole in the solenoid bracket with the locating protrusion in the frame. See Figure 7-12.
3. Install and tighten the two mounting screws. Use pliers to hold the nuts while inserting and tightening the screws. See Figure 7-13.
4. Operate the contactor using the manual operating handle to verify that the mechanism operates smoothly without binding.
5. Follow the instructions under **After Service** in Section 7.1.

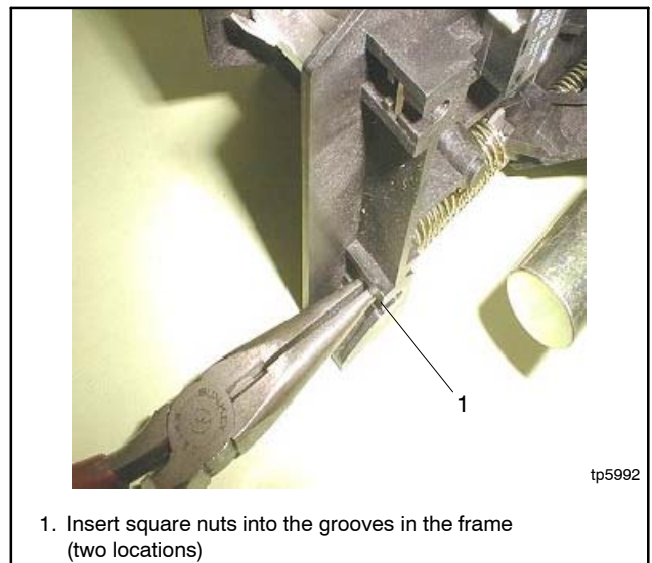
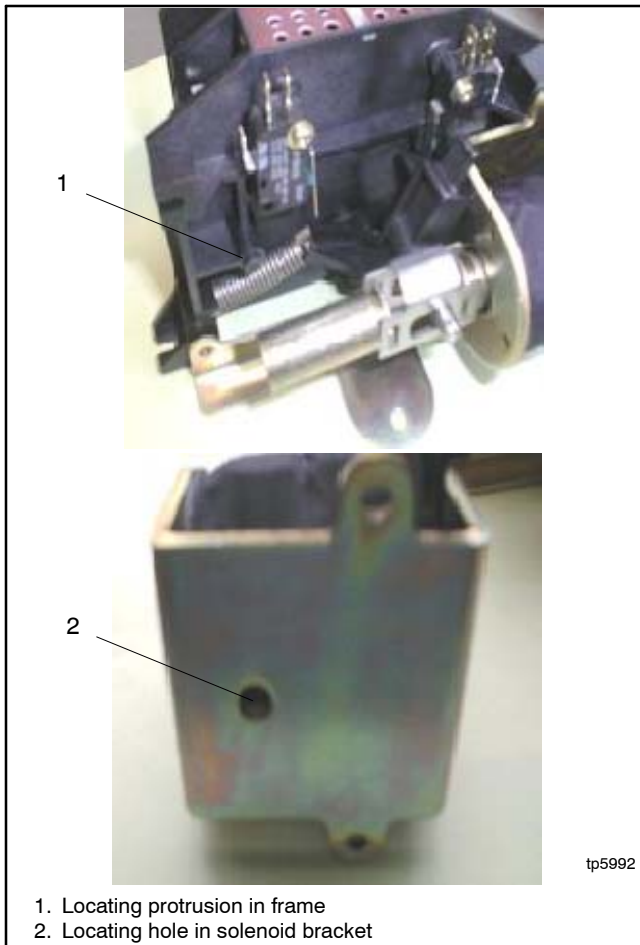

Figure 7-11 Reinstalling the Coil Assembly Nuts



1. Locating protrusion in frame
2. Locating hole in solenoid bracket

Figure 7-12 Locating the Solenoid Assembly, Typical



1. Install and tighten 2 mounting screws

Figure 7-13 Installing the Coil Assembly, Typical

7.5.3 Microswitch Replacement

Procedures shown are for the microswitch at the Emergency source coil. Use the same procedures for the microswitch at the Normal source coil.

Perform the switch replacement procedures on one source side at a time.

- To replace the microswitch at the Normal source coil, first move the contactor to the Emergency source position.
- To replace the microswitch at the Emergency source coil, first move the contactor to the Normal source position.

100 Amp Models

1. Loosen the four coil mounting screws (two for each coil) by two full rotations. Do not remove the coils. See Figure 7-14.
2. Remove the microswitch mounting screw and microswitch. See Figure 7-15 and Figure 7-16.
3. Install the new microswitch. Push the microswitch mounting screw in the direction of the arrow shown in Figure 7-15 and tighten it to 0.44 Nm (4 in. lb.).
4. Tighten the four coil mounting screws.

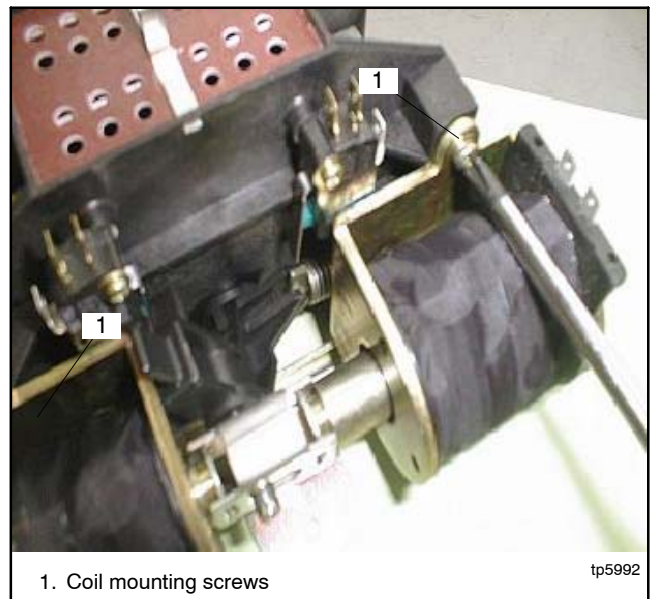

1. Coil mounting screws

Figure 7-14 Loosen Coil Mounting Screws

7.6 400 Amp Model Service

7.6.1 Disassembly/Reassembly

Dissassembly

Use this procedure to disassemble the mechanical unit and the current-carrying unit.

Note: The units shown in photos in this section may not be identical to your unit. The procedures are the same.

1. Loosen the M4 bolt (1) and remove the cover from the mechanical unit. See Figure 7-18.

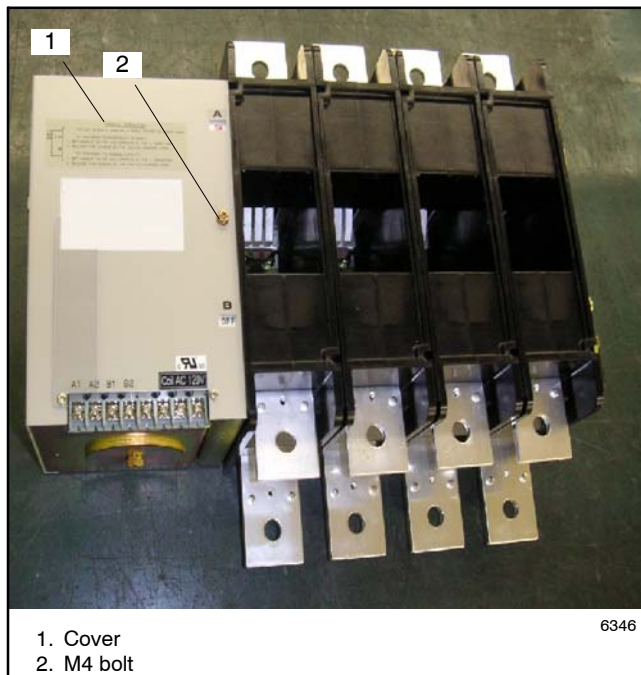

Figure 7-18 Cover

2. Remove the ON/OFF indicators. Notice that the indicators are not identical. Save them for reinstallation later.
3. Loosen the M6 bolts (4) and separate the mechanical unit from the current-carrying unit.
4. Loosen M5 bolts (2). Remove AUX lever.

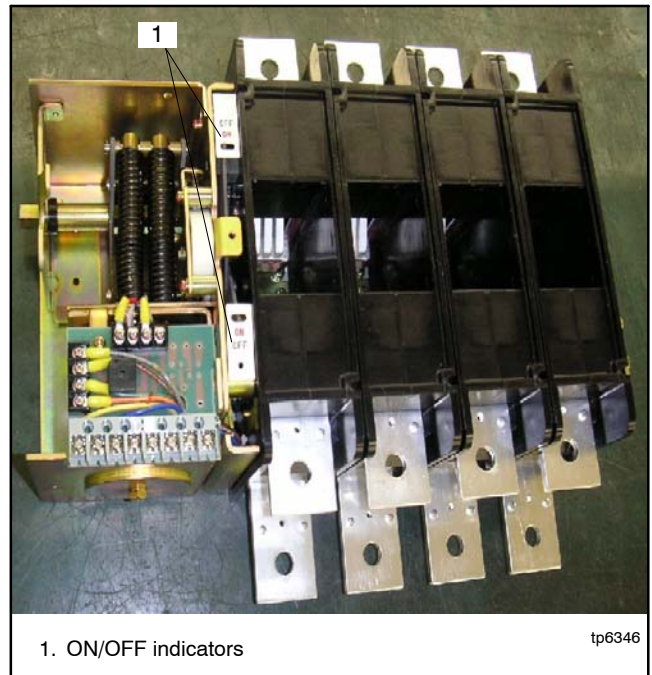

Figure 7-19 ON/OFF indicators

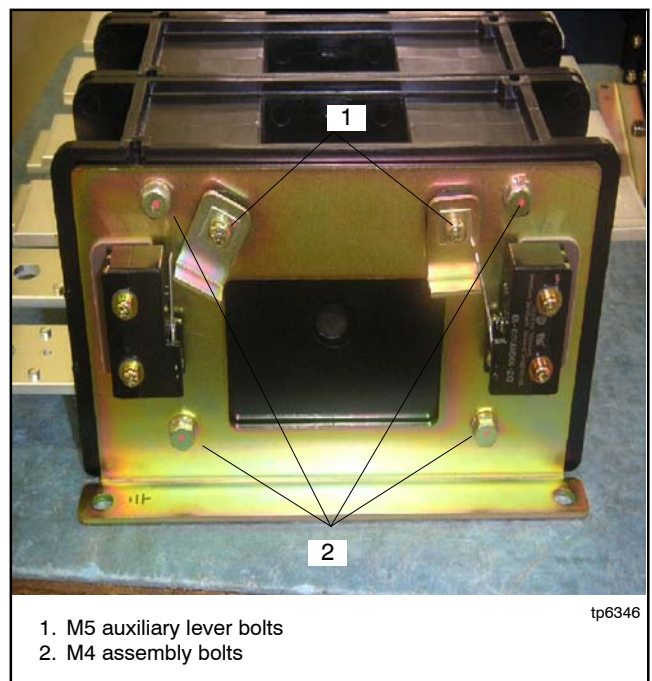

Figure 7-20 Bolts

Reassembly

Use this procedure to reassemble the current-carrying unit and the mechanical unit.

1. Pull out the main shaft levers and install the new current-carrying unit. See Figure 7-21.
2. Assemble the current-carrying unit, and the mechanical unit. See Figure 7-23.
3. Replace the auxiliary switch levers. See Figure 7-24.

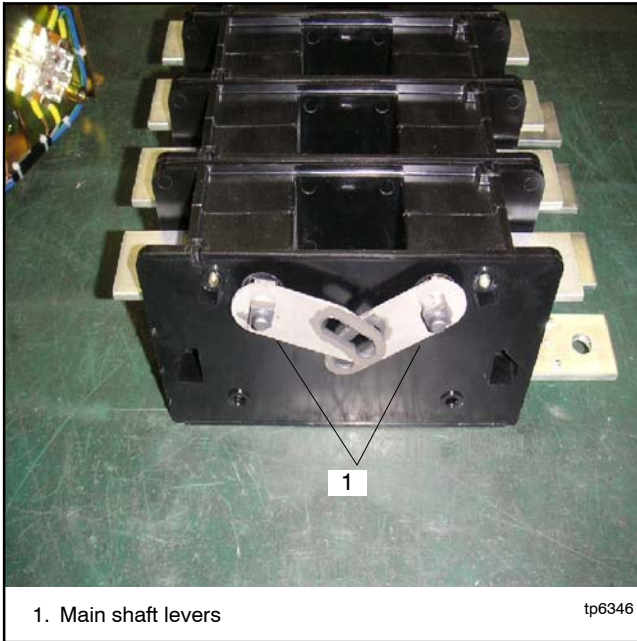

Figure 7-21 Current-Carrying Unit

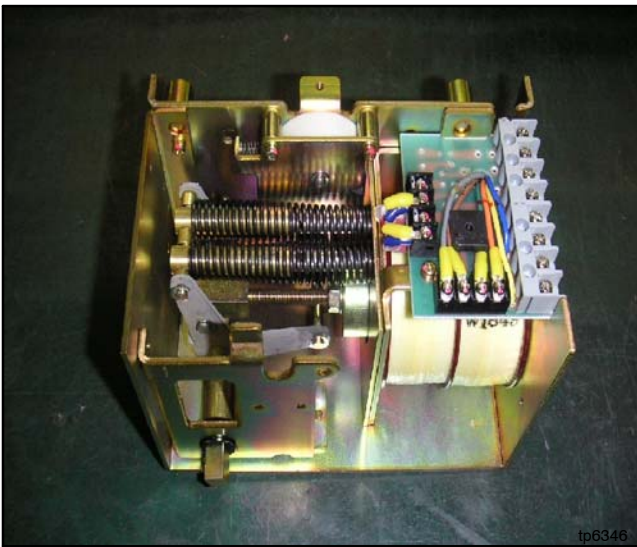

Figure 7-22 Mechanical Unit

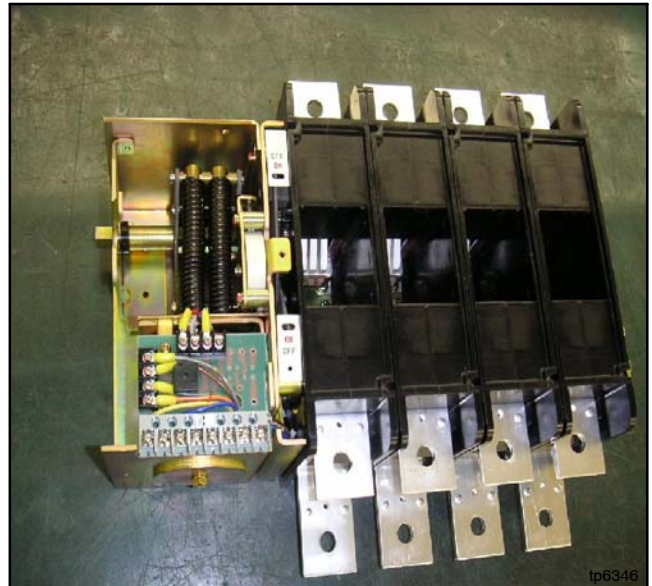

Figure 7-23 Assembled unit

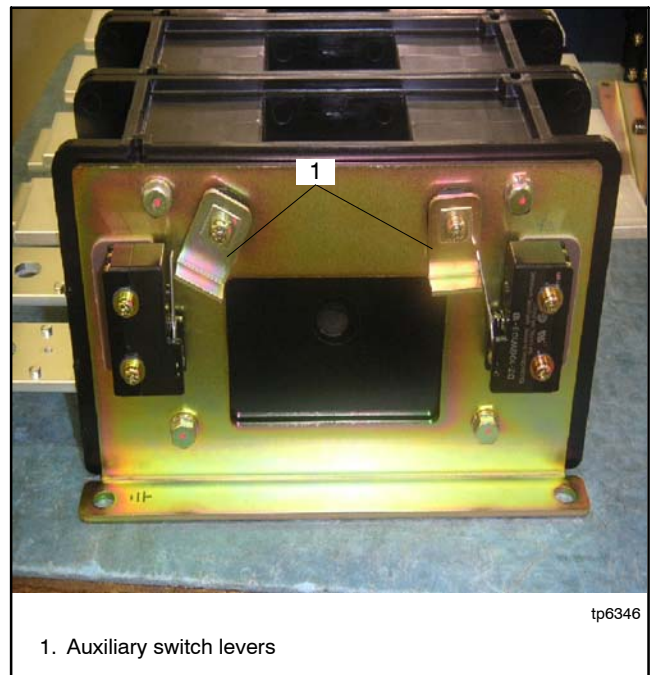

Figure 7-24 Auxiliary switch levers

7.6.2 Circuit Board Replacement

Electronic printed circuit boards (PCBs) are sensitive to a variety of elements and can be damaged during removal, installation, transportation, or storage. Observe the following when working with circuit boards.

Circuit Board Handling

- Store circuit boards in the anti-static, cushioned packaging provided by the factory in a clean environment away from moisture, vibration, static electricity, corrosive chemicals, solvents, or fumes until installation.
- Wear an approved grounding, anti-static wrist strap when handling circuit boards or components.
- Carefully hold the circuit board only by its edges, not by any of its components.
- Don't bend or drop the circuit board or any of its components.
- Don't strike the circuit board or any of its components with a hard object.
- Clean dusty or dirty circuit boards only with a vacuum cleaner or dry brush.
- Never attempt component-level circuit repairs.
- Never remove or install a circuit board with power connected.
- Label wiring when disconnecting it for reconnection later.

Procedure

1. Separate the current-carrying unit from the mechanical unit. See Section 7.6.1.
2. Note the connections and then disconnect the coil leads. See Figure 7-25.
3. Note the connections and then disconnect all control switch leads at 8 locations. See Figure 7-26.
4. Remove the M4 bolt and replace the PCB. See Figure 7-25.
5. Reconnect leads as noted.
6. Reassemble the units. See Section 7.6.1.

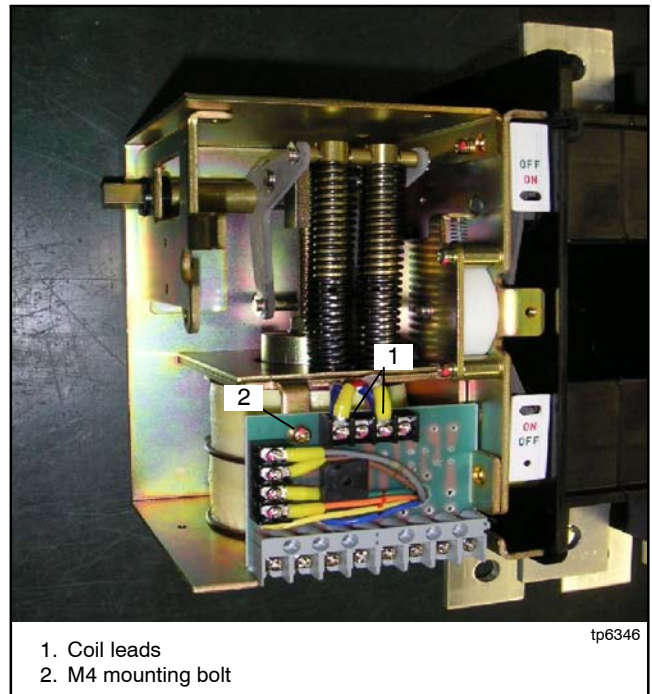

Figure 7-25 Coil leads and PCB mounting bolt

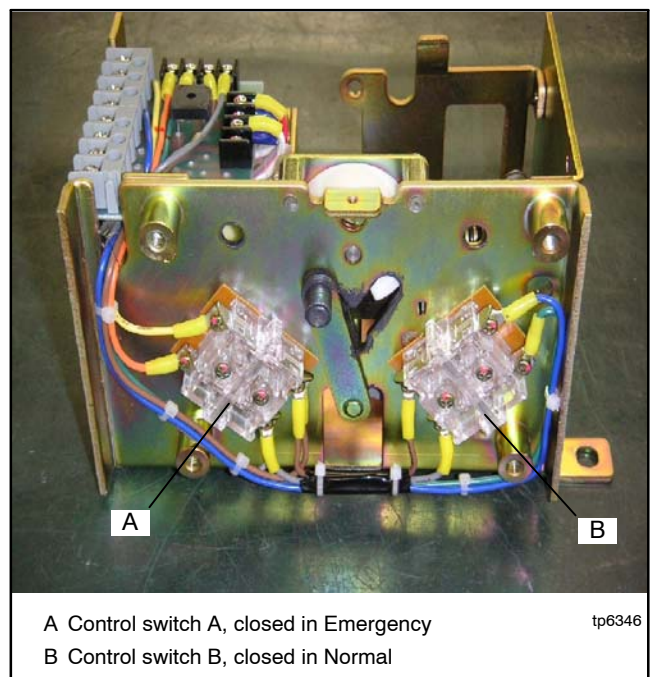

Figure 7-26 Control switches

7.6.3 Closing Coil Replacement

1. Disconnect and remove the printed circuit board (PCB). See Section 7.6.2 and Figure 7-27.
2. Remove one M6 bolt. See Figure 7-28.
3. Remove the frame with the coil from the mechanical unit. See Figure 7-29 and Figure 7-30.
4. Loosen the M6 bolt on the frame. See Figure 7-31.
5. Replace the closing coil.
6. Assemble the switch in reverse order. See Section 7.6.1.

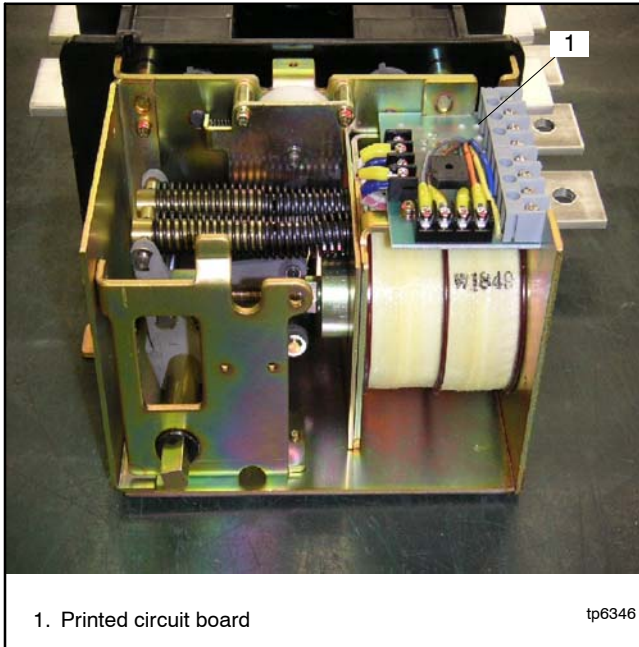

Figure 7-27 Disconnect and remove the PCB

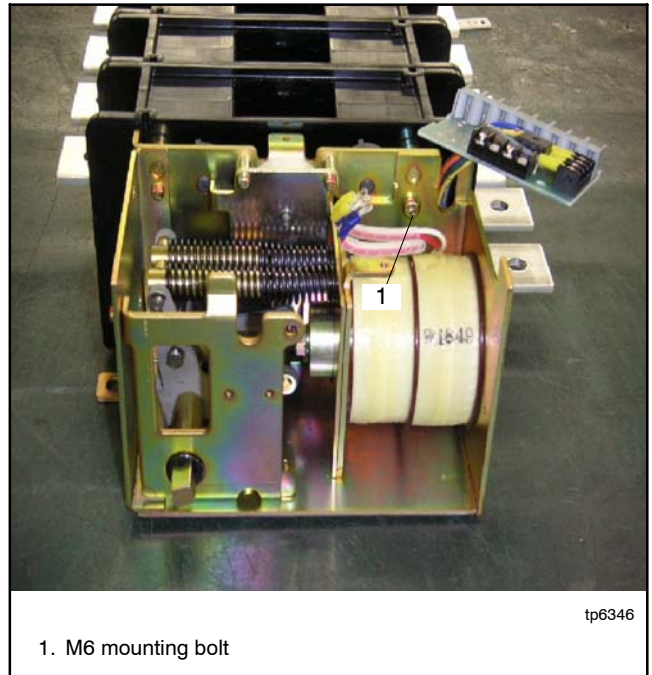

Figure 7-28 Coil frame mounting bolt

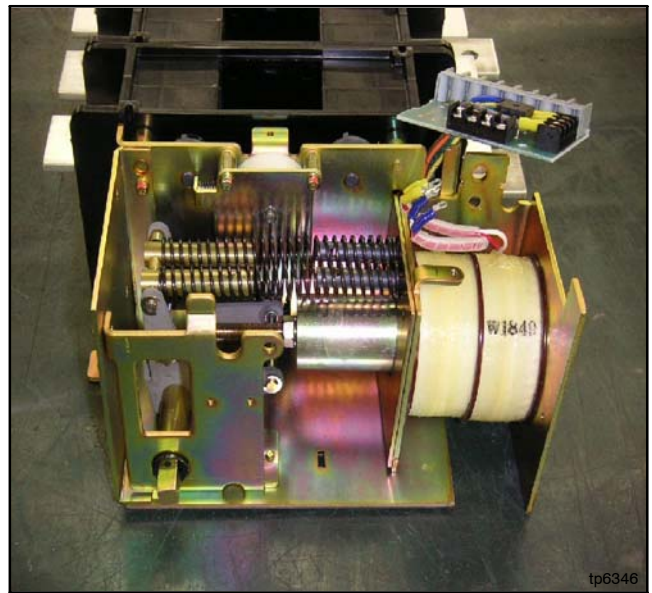

Figure 7-29 Remove the frame with the coil from the mechanical unit

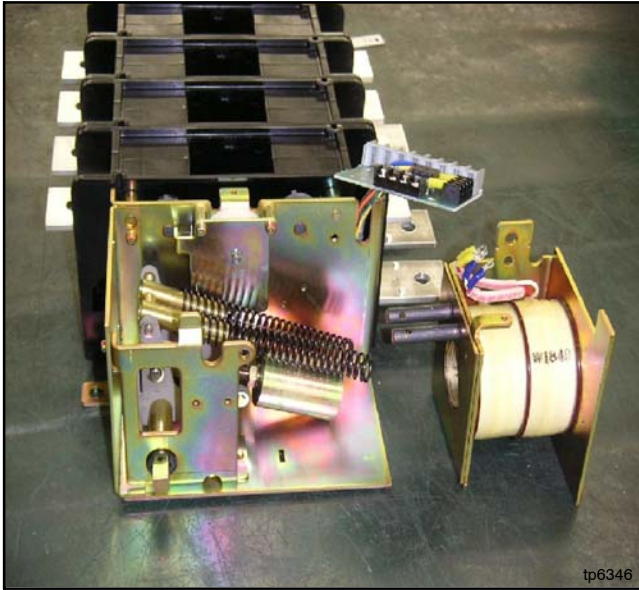
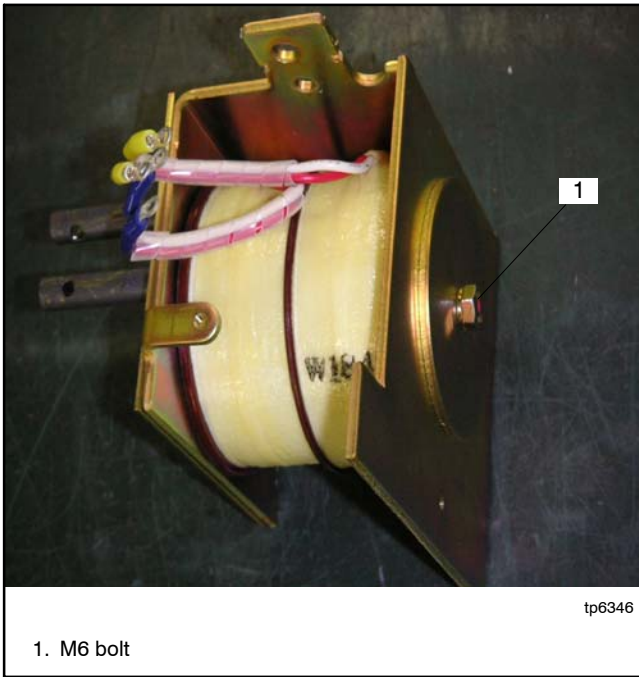

Figure 7-30 Coil and frame removed



1. M6 bolt

Figure 7-31 Loosen the M6 bolt on the frame.

7.6.4 Auxiliary Switch Replacement

1. Remove the switch mounting screw and auxiliary switch. See Figure 7-32.
2. Install the new auxiliary switch. See Figure 7-33. Tighten the screw to 0.44 Nm (4 in. lb.).



1. Auxiliary switches

Figure 7-32 Auxiliary switch Location



Figure 7-33 Auxiliary Switch and Mounting Screw

7.7 Other Service Parts

The removal and installation of other service parts listed in Section 8 for which removal and installation instructions are not previously given is covered by the following generic procedures.

7.7.1 Other Service Part Removal

1. Disable the generator set and disconnect all power sources as described in section 7.1 before opening the transfer switch enclosure.
2. Disconnect wiring from the part(s), noting the locations from which wiring was removed for later reconnection. Tape and label the wires.
3. Note the position of the part(s) and loosen or remove hardware that holds the part(s) in place. Note the location, type, and condition of hardware removed and compare it with the parts list. Replace damaged or missing hardware.
4. Carefully remove the part(s) from the unit.

Use this section to locate and identify serviceable parts for the transfer switch model covered by this manual.

8.1 Finding Parts Information

1. Decode the transfer switch model number from the nameplate to determine the transfer switch's electrical controls, voltage and frequency, poles and phases, wires, enclosure type, and current rating. See Section 8.4.
2. Locate the section that illustrates the part(s) that are needed.
3. Locate the part(s) in the illustration.
4. When there are multiple possibilities for parts, use the transfer switch characteristics determined in step 1 to locate the part number and quantity required. The quantity is shown either at the end of the description in parentheses, or in a separate column when there are alternatives.

8.2 Leads

Fabricate replacement leads using the same type of wire as the old leads. Add terminals and lead markers at each end of the new lead.

8.3 Common Hardware

Common hardware such as nuts, bolts, screws, and washers are Grade 2 unless otherwise noted and can be obtained locally if the same type and grade is available. Refer to Appendices C through E for general torque specifications and to help to identify parts that may not be shown in the parts lists.

8.4 Transfer Switch Model Designation

The transfer switch model designation defines characteristics and ratings as explained in Figure 8-1.

Model designation SE-ILC does not follow the format shown in Figure 8-1. The Model SE-ILC is a 200-amp, 240 VAC/60 Hz service entrance rated model with a 42-circuit load center and circuit breaker disconnects for the sources. Parts for the Model SE-ILC are shown in the following tables.

8.5 Parts Lists

Parts lists appear on the following pages.

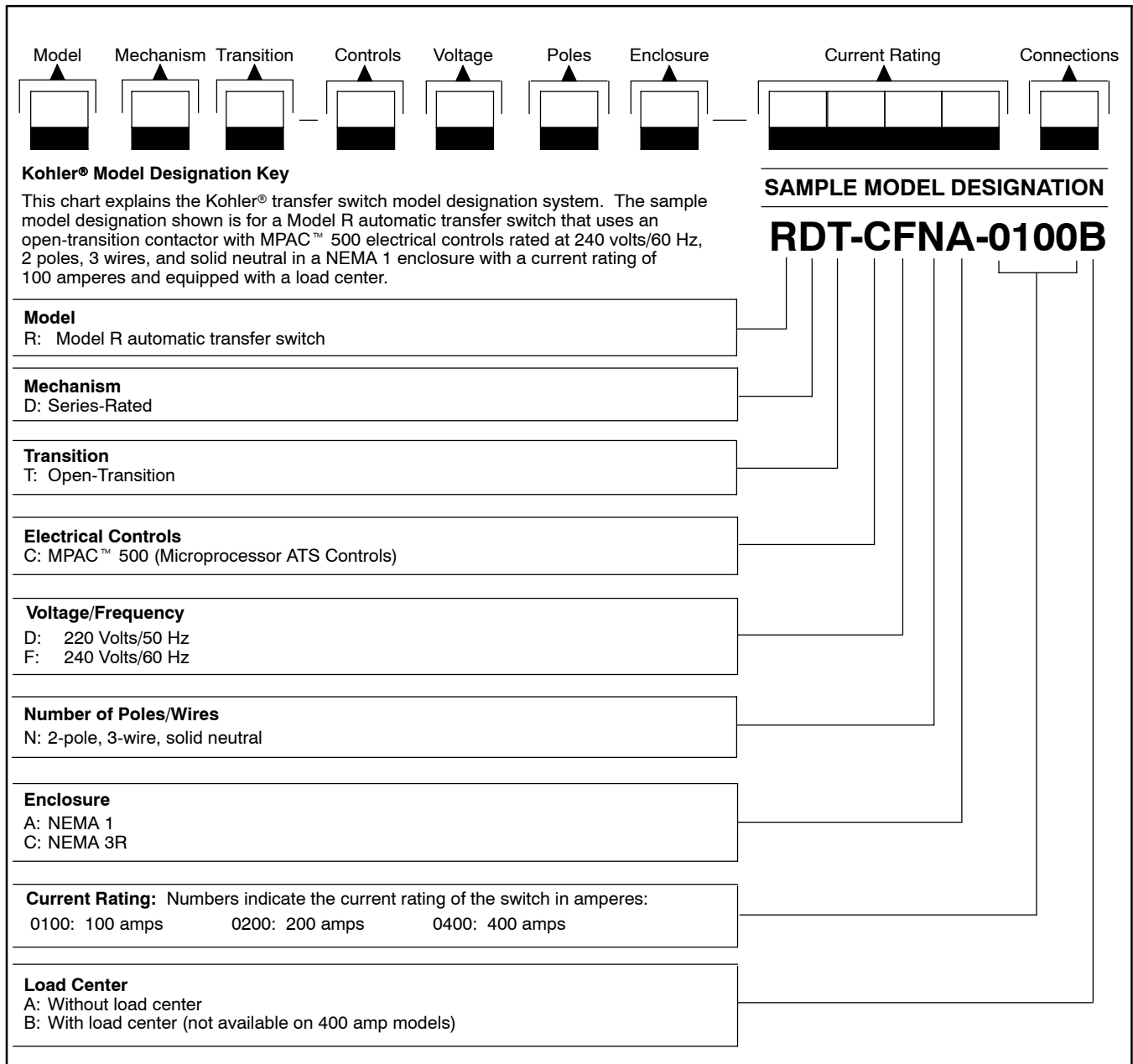
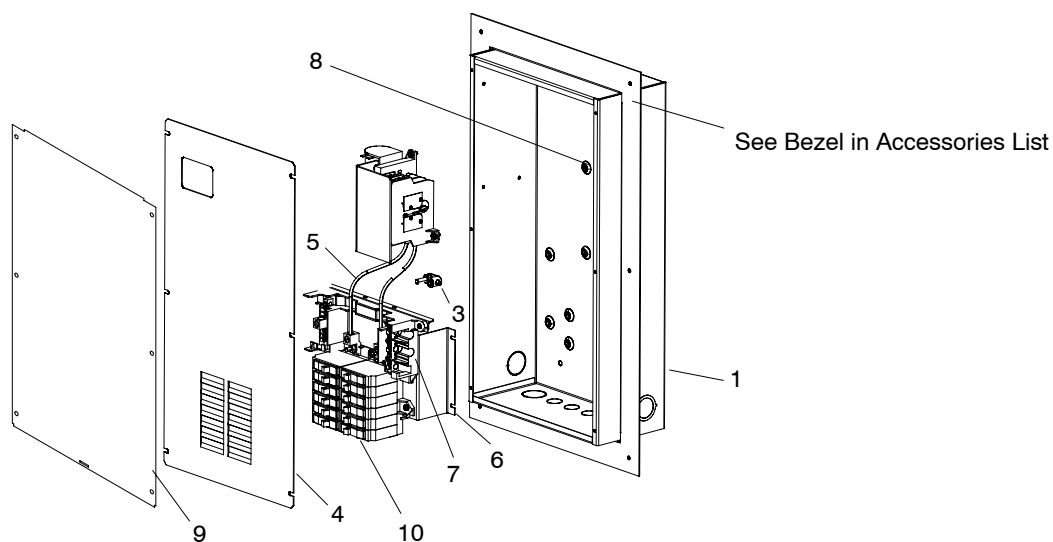

Figure 8-1 Model Designation

Enclosure and Door, 100/200 Amp

Items not shown: 2



100/200 Amp

pb122_1

Item	Description	Part Number							
		Without Load Center				With Load Center			
		NEMA 1		NEMA 3R		NEMA 1		NEMA 3R	
	100 Amp	200 Amp	100 Amp	200 Amp	100 Amp	200 Amp	100 Amp	200 Amp	
1	Enclosure, ATS	GM36132	GM36132	GM36211	GM36211	GM36132	GM36133	GM36211	GM36212
2	Decal, ATS ratings (not shown)	GM33005	GM33006	GM33005	GM33006	N/A	N/A	N/A	N/A
3	Lug	362126	362126	362126	362126	362126	362126	362126	362126
4	Cover	GM39387	GM39387	GM39392	GM39392	GM39388	GM39389	GM39393	GM39394
5	Cable, lead	N/A	N/A	N/A	N/A	GM39361	GM39362	GM39361	GM39362
6	Bracket, mounting	N/A	N/A	N/A	N/A	GM36152	GM36151	GM36152	GM36151
7	Base, load center	N/A	N/A	N/A	N/A	GM37536	GM37537	GM37536	GM37537
8	Gasket (qty. 4)	N/A	N/A	GM20990	GM20990	N/A	N/A	GM20990	GM20990
9	Cover	N/A	N/A	GM39390	GM39390	N/A	N/A	GM39390	GM39391
10	Circuit breakers. See note below.	N/A	N/A	N/A	N/A	N/A	N/A	N/A	N/A

N/A Not applicable

Note: Because the size and number of circuit breakers required will vary with each application, load center circuit breakers are not provided with the transfer switch. Obtain Square D type QO circuit breakers locally.

Enclosure and Door, SE-ILC

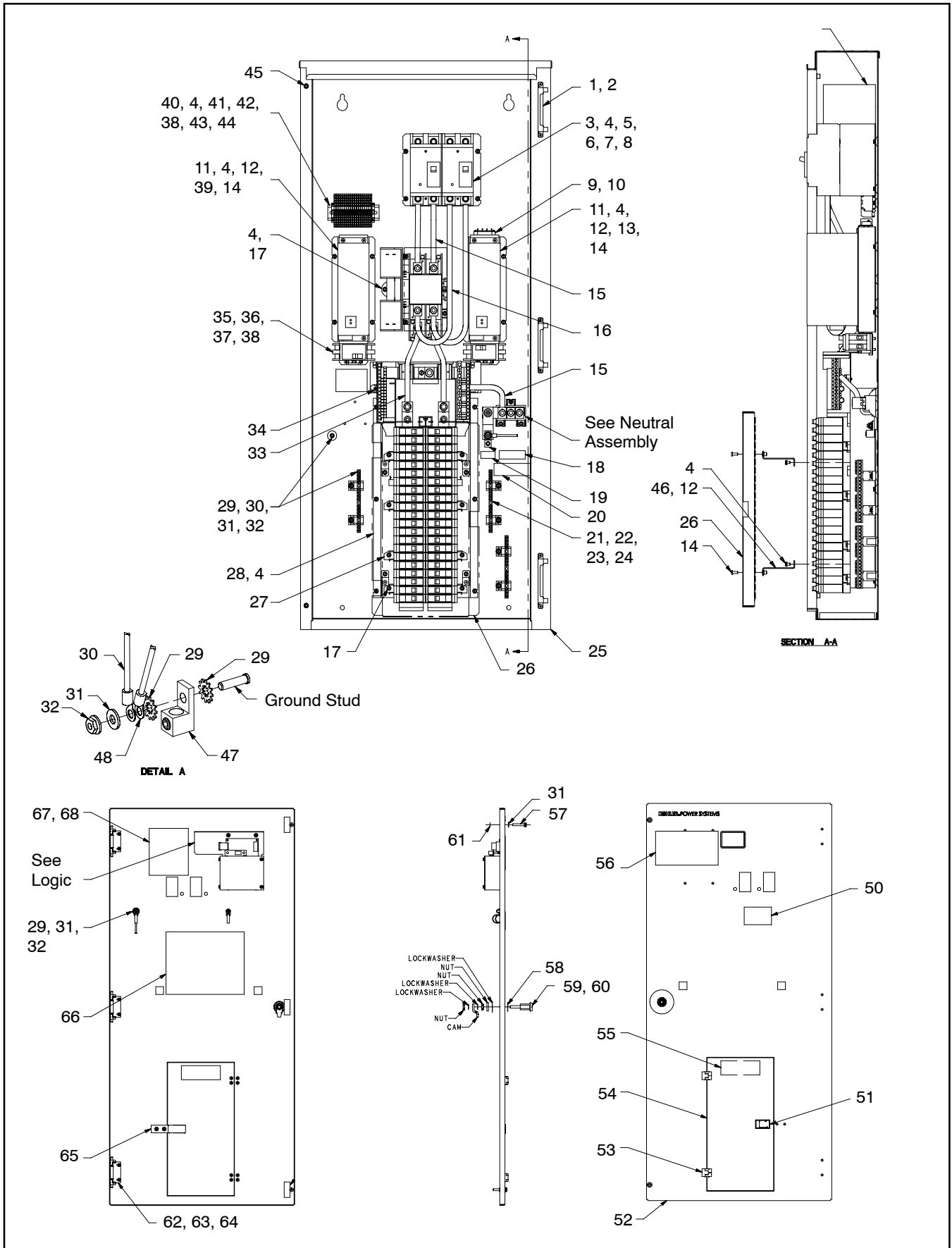

Enclosure and Door, SE-ILC

Item	Part No.	Description	Qty.
1	GM20572-1	Hinge, ATS enclosure	3
2	X-50-1	Screw, pan head 10-32 x 1/2	6
3	GM40038	Bracket, CB mounting	2
4	X-67-155	Screw, tapping	25
5	353123	Insert, threaded, #8-32	4
6	GM39745	Breaker, circuit	2
7	X-51-47	Screw, slotted pan head machine	2
8	X-51-40	Screw, pan head 8/32 x 2-1/4	2
9	223096	Strip, terminal	1
10	X-67-152	Screw, tapping	2
11	GM40040	Bracket, surge protector mtg.	2
12	346258	Insert, threaded, #10-24	12
13	GM42272	Surge protector assembly, emergency	1
14	X-50-15	Screw, pan head 10-24 x 1/2	12
15	GM39912	Cable, lead	3
16	GM39913	Cable, lead	2
17	X-67-156	Screw, tapping	14
18	GM12385	Decal	1
19	344295	Decal, equipment ground	1
20	GM24703	Label, blank	2
21	GM41104	Foot, ground bar insulator	3
22	X-25-36	Washer, plain, .219 ID x .5 in. OD	6
23	X-67-118	Screw, hex washer, thread-forming	6
24	GM41103	Bar, grounding - 15 position	3
25	GM39747	Enclosure, ATS	1
26	GM39755	Panel, circuit breaker	1
27	GM39746	Base, load center	1
28	GM41100	Bracket, LC mtg.	1
29	X-22-12	Washer, lock, .262 ID x .743 in. OD	3
30	LK-1208-1500	Lead	2
31	X-25-40	Washer, plain, .281 ID x .625 in. OD	5
32	X-6210-2	Nut, flange spirallock, 1/4-20	5
33	GM39914	Cable, lead	2
34	X-67-124	Screw, cross-recess thread-forming	2
35	GM30041	Rail, DIN	2
36	X-67-113	Screw, hex washer, thread-forming	4
37	GM39763	Breaker, circuit	2
38	GM36087	End stop, screwless gray	4
39	GM42270	Surge protector assembly, normal	1
40	GM41099	Rail, din	1
41	GM36084	Terminal block, cage clamp 4-pole gray	18
42	GM36085	End plate, 4-pole gray	1
43	GM36117	Wire marker 1-10	1
44	GM36118	Wire marker 11-20	1
45	320828	Insert, threaded, 1/4-20 in.	2
46	GM42203	Bracket, CB panel mtg.	4
47	X-6207-3	Lug, terminal, aluminum	1
48	LK-1263-1515	Lead	1
49	GM41194	Decal, CB	1
50	GM12386	Decal, danger	1
51	GM41102	Latch, push to close	1
52	GM39748	Door, enclosure	1
53	GM41101	Hinge	2
54	GM41105	Door, circuit breaker	1
55	GM39383	Decal, CB	1
56	GM39381	Decal, UIF	1
57	X-791-3	Screw, slotted hex washer head, machine	2
58	GM20575	Gasket, compression latch	1
59	GM20573	Latch, compression	1
60	GM20574	Key, compression latch	2
61	295009	Retainer	2
62	GM20572-2	Hinge, ATS enclosure	3
63	X-22-9	Washer, lock, .20 ID x .373 in. OD	6
64	X-70-3	Nut, hex machine screw, 10-32	6
65	GM42199	Plate, latch	1
66	GM39382	Decal, wiring	1
67	GM21291	Decal, nameplate	1
68	GM39624	Decal, U.L.	1
69	GM41189	Decal, CB (not shown)	1

Enclosure and Door, 400 Amp

Items not shown: 25, 26, 27

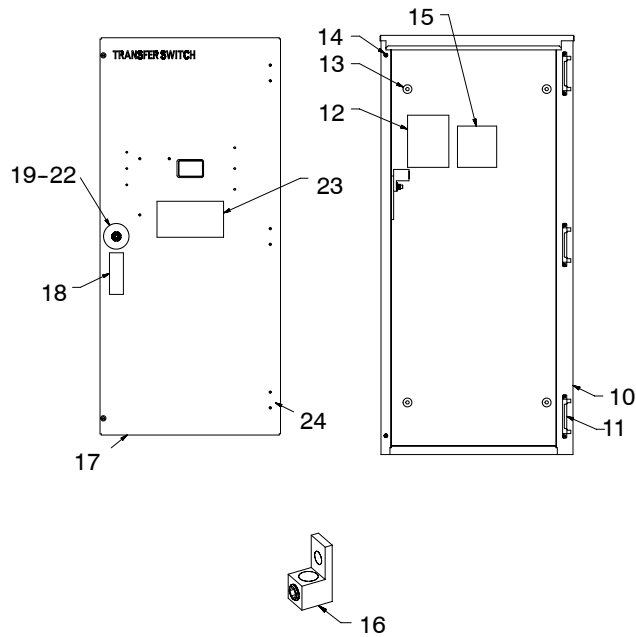

pb122_2

Item	Part No.	Description	Quantity	
			NEMA 1	NEMA 3R
10	GM37626	Enclosure, ATS	1	1
11	GM20572-1	Hinge, ATS enclosure	3	3
12	GM32651	Decal, ATS rating	1	1
13	GM20990	Gasket	4	4
14	320828	Insert, threaded	2	2
14	295009	Retainer	2	2
15	294414	Decal, notice	1	1
16	X-6207-3	Lug	1	1
17	GM37627	Door, enclosure	1	
17	GM38438	Door, enclosure		1
18	362176	Decal, danger	1	1
19	GM20576	Bracket, padlock	1	1
20	GM20573	Latch	1	1
21	GM20575	Gasket, latch	1	1
22	GM20574	Keys	1	1
23	GM39381	Decal, UIF	1	1
24	GM20572-2	Hinge, ATS door	3	3
25	297556	Decal, torque (not shown)	1	1
26	344295	Decal, equipment ground (not shown)	1	1
27	297721	Decal, CSA (not shown)	1	1

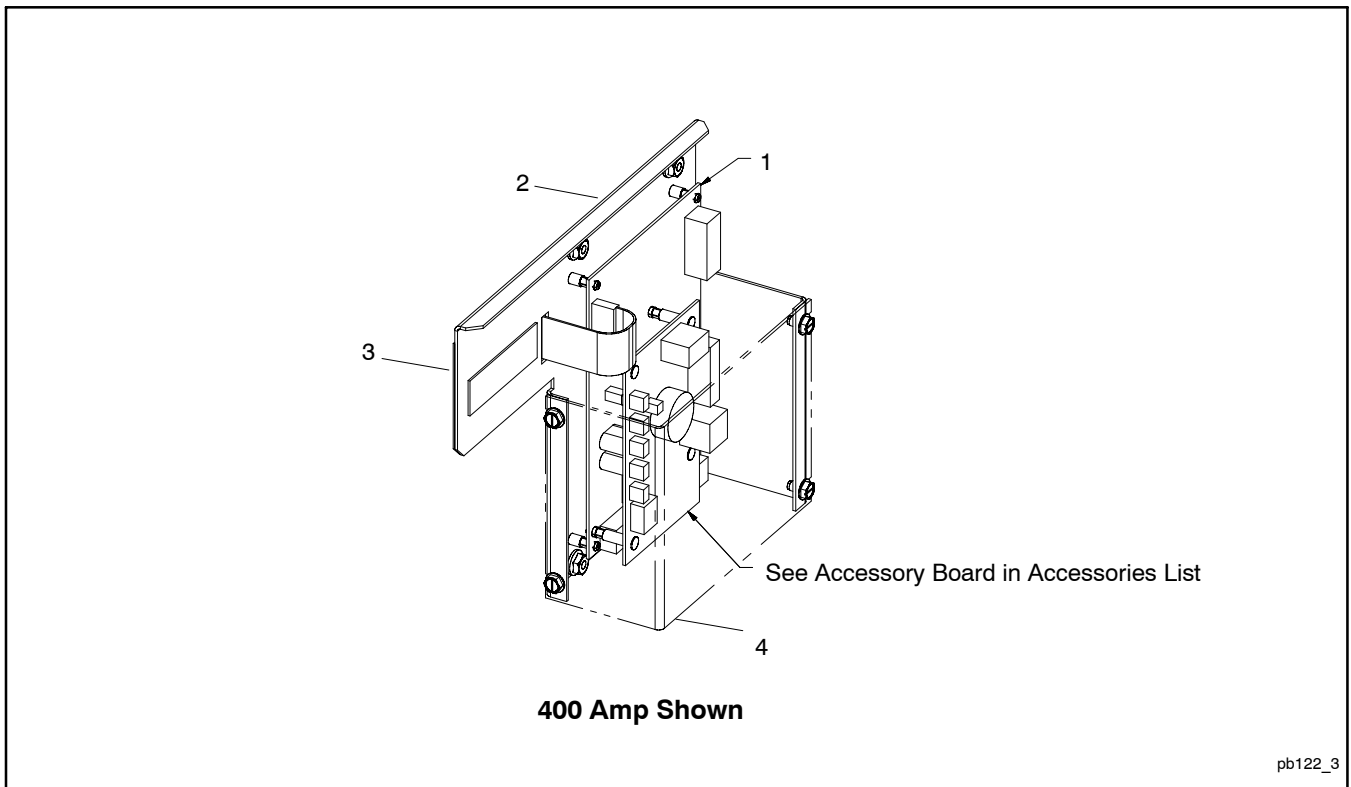

Item	Part No.	Description	Quantity		
			100/200 Amp	400 Amp	SE-ILC
1	GM35950	PCB assy, 500 logic board	1	1	1
2	GM37541	Bracket, controller mtg.	1		
2	GM37628	Bracket, controller mtg.		1	1
3	GM38355	Membrane switch/LED	1	1	1
4	GM38436	Guard, controller		1	1

Neutral Assembly

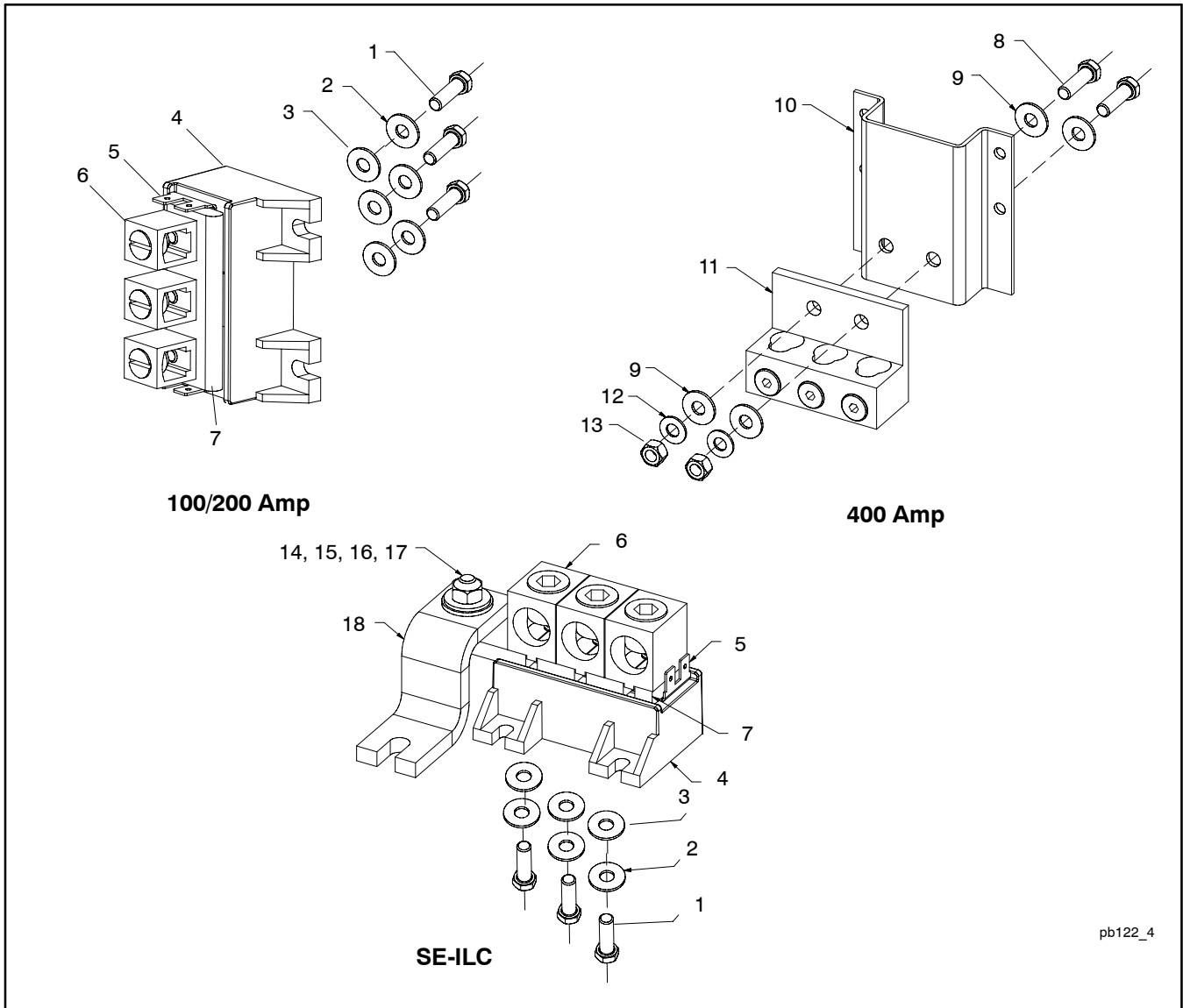

pb122_4

Item	Part Number	Description	Quantity			
			100 A	200 A	400 A	SE-ILC
1	X-50-4	Screw, pan head	3			
1	X-465-16	Bolt, hex cap		3		3
2	X-6086-23	Washer	3			
2	X-6086-24	Washer		3		3
3	X-25-36	Washer, plain	3			
3	X-25-20	Washer, plain, .312 ID x .75 OD		3		3
4	GM36201	Base, neutral	1	1		1
5	GM31854	Terminal, ATS lug sensing	2	2		1
6	GM28412	Lug, terminal	3			
6	297712	Lug, terminal		3		3
7	GM36202	Bus, neutral	1			
7	GM36203	Bus, neutral		1		
7	GM41119	Bus, neutral				1
8	X-6238-4	Bolt, hex cap			2	
9	X-25-118	Washer, plain			4	
10	GM25826	Bracket, neutral mtg.			1	
11	X-6207-14	Lug, terminal			1	
12	X-6086-6	Washer, spring			2	
13	X-83-7	Nut, hex			2	
14	X-25-20	Washer, plain, .312 ID x .75 OD				1
15	X-6086-24	Washer				1
16	X-465-7	Bolt, hex cap				1
17	X-81-10	Nut, hex, 1/4-20				1
18	GM40058	Bus, neutral				1

Contactor, 100/200 Amp

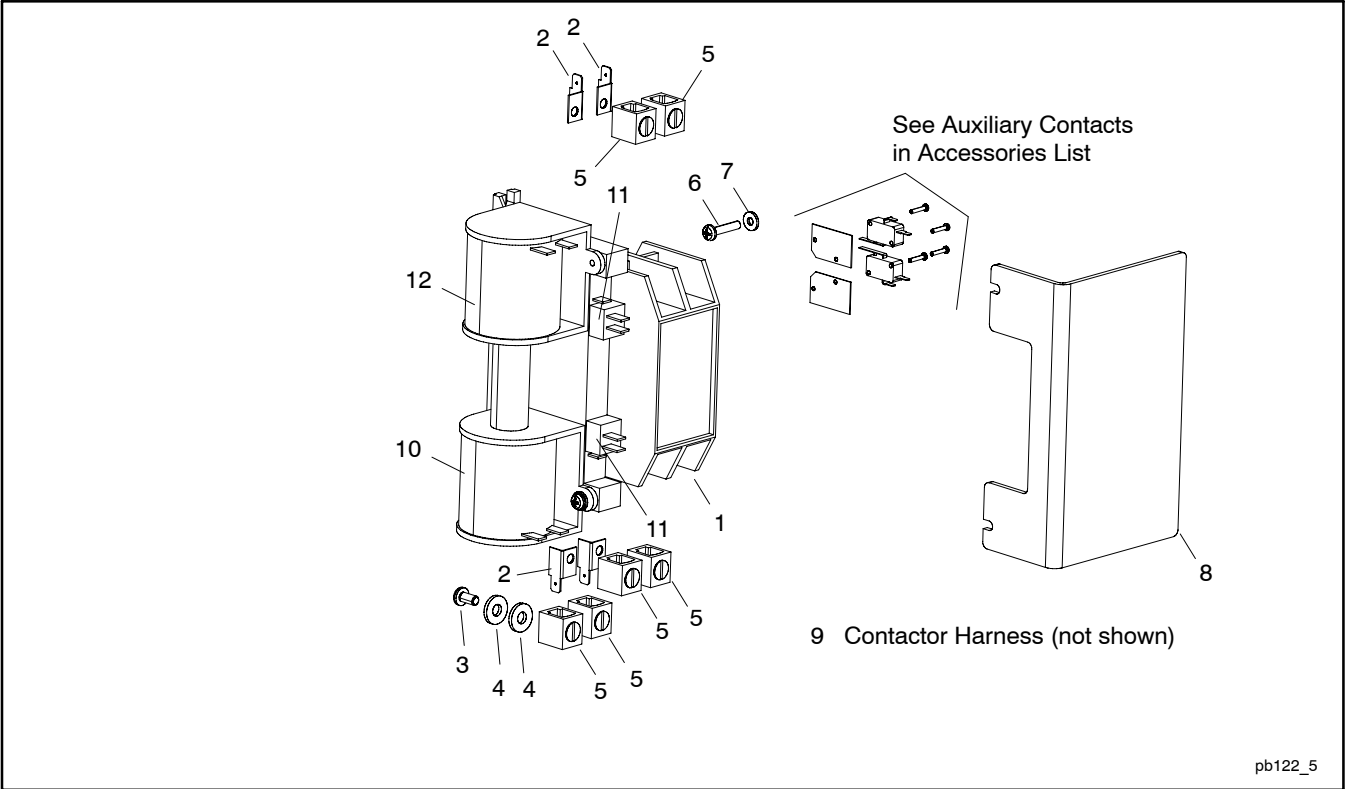

pb122_5

Item	Part Number	Description	Quantity		
			100 A	200 A	SE-ILC
1	GM41938	Contactor, 100A, 2P, 240V (includes items 2-8, 10, 11, 12)	1		
1	GM41939	Contactor, 200A, 2P, 240V (includes items 2-8, 10, 11, 12)		1	1
2	GM31593	Terminal, ATS lug sensing	6		
3	X-50-2	Screw, pan head, 10-32 x 3/8	6		
3	X-465-6	Bolt, hex cap		6	
4	X-25-36	Washer, plain	6		
4	X-25-20	Washer, plain		6	6
4	X-6086-23	Washer, spring	6		
4	X-6086-24	Washer, spring		6	6
5	GM28412	Lug, terminal	6		
5	297712	Lug, terminal		6	6
6	M7985A-04020-20	Screw	2		
7	X-25-9	Washer	2		
8	GM29825	Guard, contactor	1		
9	GM37646	Harness, contactor (not shown)	1		
9	GM37647	Harness, contactor (not shown)		1	
9	GM39847	Harness, contactor (not shown)			1
10	GM29864	Coil (lower)	1		
10	GM29865	Coil (lower)		1	1
11	GM29867	Switch, limit	2	2	2
12	GM29863	Coil (upper)	1		
12	GM29865	Coil (upper)		1	1
13	GM39846	Harness, wiring, MPAC 500 cust. connect. (not shown)			1

Contactor, 400 Amp

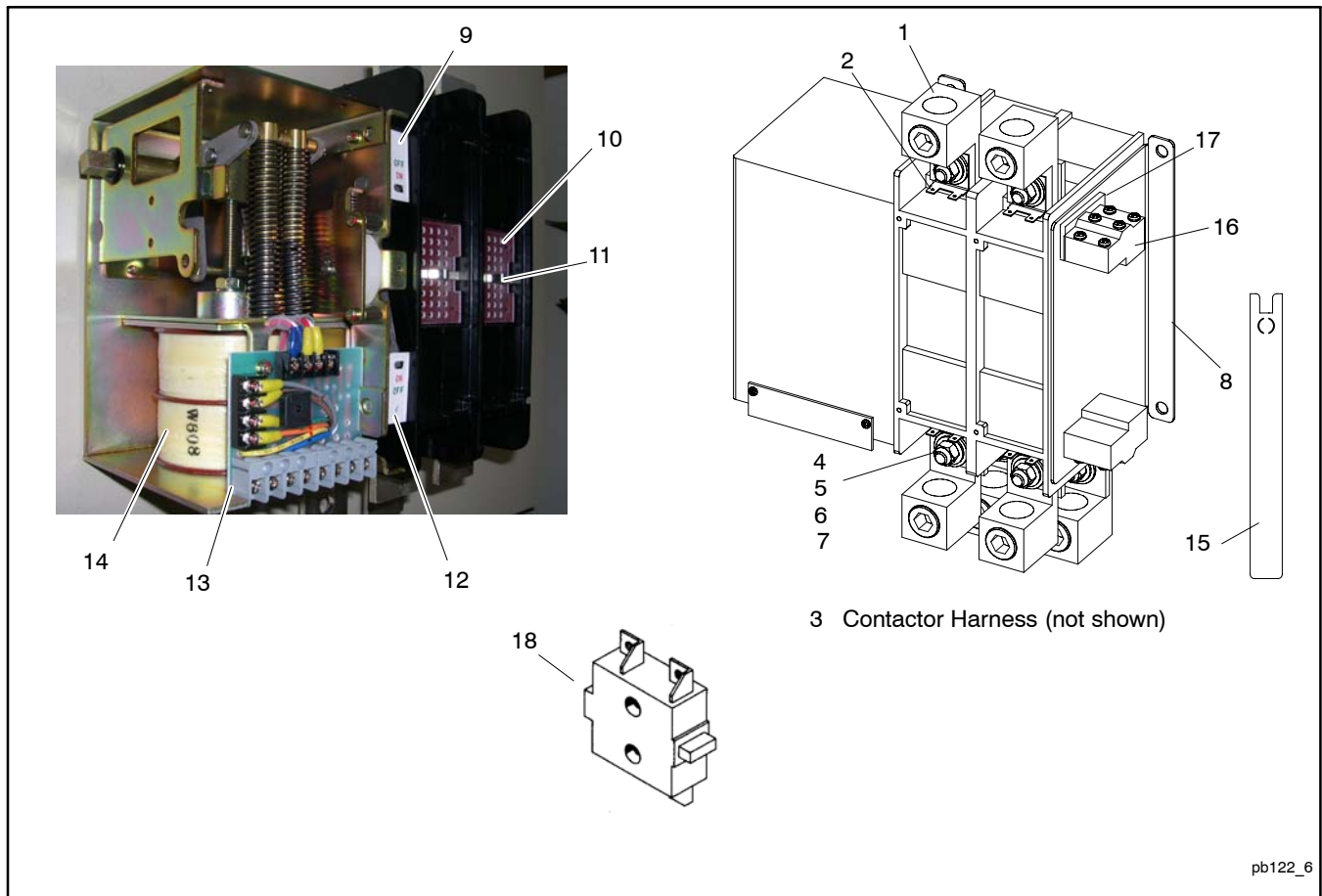

Item	Part No.	Description	Qty.
1	X-6207-9	Lug, terminal	6
2	GM31855	Terminal, ATS lug sensing	4
3	GM38321	Harness, contactor (not shown)	1
4	X-25-118	Washer, plain	12
5	X-6086-6	Washer, spring	6
6	X-83-7	Nut, hex	6
7	X-6238-4	Bolt, hex cap	6
8	GM37643	Contactor, 400A, 2P, 240V	1
9	GM32486	OFF-ON indicator	1
10	GM32479	Arc Chute	2
11	GM32482	Clip, arc chute	2
12	GM32487	ON-OFF indicator	1
13	GM40187	PCB, bridge rectifier	1
14	GM32492	Coil	1
15	GM32475	Handle	1
16	GM32485	Aux. switch	2
17	GM32484	Insulating barrier for aux. switch	2
18	GM32483	Control switch	2

Literature

Part No.	Description	Quantity	
		RDT	SE-ILC
TP-5373	Warranty, 1-year limited	1	1
TP-6265	Warranty, 2-year extended	1	1
TP-6345	O/I/M Model RDT ATS	1	
TP-6378	O/I/M Model SE-ILC ATS		1
TP-6346	S/M RDT, SE-ILC ATS	1	1
G25-15	Template, RDT Mounting	1	

Accessories

Qty.	Description	Part Number
------	-------------	-------------

Accessory Board GM38796-KA1

1	Header, PCB pin, 4-position, gold	GM38445
1	PCB assembly, time delay option	GM39650

Programmable Exerciser, 100/200 Amp GM38798-KA1

2	Terminal, ATS lug sensing	GM31593
1	Bracket, timer mounting	GM38801
1	Control, time electronic	GM39330
1	Diagram, wiring	GM39331
1	Installation instructions, programmable exerciser	TT-1403

Programmable Exerciser, 400 Amp GM40033-KA1

2	Terminal, ATS lug sensing	GM31855
1	Bracket, timer mounting	GM40024
1	Control, time electronic	GM39330
1	Diagram, wiring	GM39331
1	Installation instructions, programmable exerciser	TT-1403

Auxiliary Contacts GM29856-KA1

2	Switch, contactor aux.	362081
2	Insulator, contactor aux. switch	362203
4	Screw, slotted pan head machine	X-49-41

Padlockable User Interface Cover, 400 A Only GM22703-KA5

2	Bracket, padlock	GM20576
1	Cover, security	GM22504
1	Bracket, latch	GM22533
1	Latch, compression (key operated)	GM22534
1	Key, compression latch	GM20574
1	Installation instructions, user interface cover	TT-1319

Bezel, 100/200 A w/out Load Center and 100 A with Load Center GM38799-KP2

1	Bezel, ATS	GM38810
6	Screw, tapping	X-67-156

17	GM37627	Door, enclosure	1	
17	GM38438	Door, enclosure		1

Appendix A Abbreviations

The following list contains abbreviations that may appear in this publication.

A, amp	ampere	cfm	cubic feet per minute	exh.	exhaust
ABDC	after bottom dead center	CG	center of gravity	ext.	external
AC	alternating current	CID	cubic inch displacement	F	Fahrenheit, female
A/D	analog to digital	CL	centerline	fglass.	fiberglass
ADC	analog to digital converter	cm	centimeter	FHM	flat head machine (screw)
adj.	adjust, adjustment	CMOS	complementary metal oxide substrate (semiconductor)	fl. oz.	fluid ounce
ADV	advertising dimensional drawing	cogen.	cogeneration	flex.	flexible
AHWT	anticipatory high water temperature	com	communications (port)	freq.	frequency
AISI	American Iron and Steel Institute	coml	commercial	FS	full scale
ALOP	anticipatory low oil pressure	Coml/Rec	Commercial/Recreational	ft.	foot, feet
alt.	alternator	conn.	connection	ft. lb.	foot pounds (torque)
Al	aluminum	cont.	continued	ft./min.	feet per minute
ANSI	American National Standards Institute (formerly American Standards Association, ASA)	CPVC	chlorinated polyvinyl chloride	g	gram
AO	anticipatory only	crit.	critical	ga.	gauge (meters, wire size)
API	American Petroleum Institute	CRT	cathode ray tube	gal.	gallon
approx.	approximate, approximately	CSA	Canadian Standards Association	gen.	generator
AR	as required, as requested	CT	current transformer	genset	generator set
AS	as supplied, as stated, as suggested	Cu	copper	GFI	ground fault interrupter
ASE	American Society of Engineers	cu. in.	cubic inch	GND, 	ground
ASME	American Society of Mechanical Engineers	cw.	clockwise	gov.	governor
assy.	assembly	CWC	city water-cooled	gph	gallons per hour
ASTM	American Society for Testing Materials	cyl.	cylinder	gpm	gallons per minute
ATDC	after top dead center	D/A	digital to analog	gr.	grade, gross
ATS	automatic transfer switch	DAC	digital to analog converter	GRD	equipment ground
auto.	automatic	dB	decibel	gr. wt.	gross weight
aux.	auxiliary	dBA	decibel (A weighted)	H x W x D	height by width by depth
A/V	audiovisual	DC	direct current	HC	hex cap
avg.	average	DCR	direct current resistance	HCHT	high cylinder head temperature
AVR	automatic voltage regulator	deg., °	degree	HD	heavy duty
AWG	American Wire Gauge	dept.	department	HET	high exhaust temperature, high engine temperature
AWM	appliance wiring material	dia.	diameter	hex	hexagon
bat.	battery	DI/EO	dual inlet/end outlet	Hg	mercury (element)
BBDC	before bottom dead center	DIN	Deutsches Institut für Normung e. V. (also Deutsche Industrie Normenausschuss)	HH	hex head
BC	battery charger, battery charging	DIP	dual inline package	HHC	hex head cap
BCA	battery charging alternator	DPDT	double-pole, double-throw	HP	horsepower
BCI	Battery Council International	DPST	double-pole, single-throw	hr.	hour
BDC	before dead center	DS	disconnect switch	HS	heat shrink
BHP	brake horsepower	DVR	digital voltage regulator	hsg.	housing
blk.	black (paint color), block (engine)	E, emer.	emergency (power source)	HVAC	heating, ventilation, and air conditioning
blk. htr.	block heater	EDI	electronic data interchange	HWT	high water temperature
BMEP	brake mean effective pressure	EFR	emergency frequency relay	Hz	hertz (cycles per second)
bps	bits per second	e.g.	for example (<i>exempli gratia</i>)	IC	integrated circuit
br.	brass	EG	electronic governor	ID	inside diameter, identification
BTDC	before top dead center	EGSA	Electrical Generating Systems Association	IEC	International Electrotechnical Commission
Btu	British thermal unit	EIA	Electronic Industries Association	IEEE	Institute of Electrical and Electronics Engineers
Btu/min.	British thermal units per minute	EI/EO	end inlet/end outlet	IMS	improved motor starting
C	Celsius, centigrade	EMI	electromagnetic interference	in.	inch
cal.	calorie	emiss.	emission	in. H ₂ O	inches of water
CARB	California Air Resources Board	eng.	engine	in. Hg	inches of mercury
CB	circuit breaker	EPA	Environmental Protection Agency	in. lb.	inch pounds
cc	cubic centimeter	EPS	emergency power system	Inc.	incorporated
CCA	cold cranking amps	ER	emergency relay	ind.	industrial
ccw.	counterclockwise	ES	engineering special, engineered special	int.	internal
CEC	Canadian Electrical Code	ESD	electrostatic discharge	int./ext.	internal/external
cert.	certificate, certification, certified	est.	estimated	I/O	input/output
cfh	cubic feet per hour	E-Stop	emergency stop	IP	iron pipe
		etc.	et cetera (and so forth)	ISO	International Organization for Standardization
				J	joule
				JIS	Japanese Industry Standard

k	kilo (1000)	MTBF	mean time between failure	RHM	round head machine (screw)
K	kelvin	MTBO	mean time between overhauls	rly.	relay
kA	kiloampere	mtg.	mounting	rms	root mean square
KB	kilobyte (2 ¹⁰ bytes)	MW	megawatt	rnd.	round
kg	kilogram	mW	milliwatt	ROM	read only memory
kg/cm ²	kilograms per square centimeter	μF	microfarad	rot.	rotate, rotating
kgm	kilogram-meter	N, norm.	normal (power source)	rpm	revolutions per minute
kg/m ³	kilograms per cubic meter	NA	not available, not applicable	RS	right side
kHz	kilohertz	nat. gas	natural gas	RTV	room temperature vulcanization
kJ	kilojoule	NBS	National Bureau of Standards	SAE	Society of Automotive Engineers
km	kilometer	NC	normally closed	scfm	standard cubic feet per minute
kOhm, kΩ	kilo-ohm	NEC	National Electrical Code	SCR	silicon controlled rectifier
kPa	kilopascal	NEMA	National Electrical Manufacturers Association	s, sec.	second
kph	kilometers per hour	NFPA	National Fire Protection Association	SI	<i>Systeme international d'unites</i> , International System of Units
kV	kilovolt	Nm	newton meter	SI/EO	side in/end out
kVA	kilovolt ampere	NO	normally open	sil.	silencer
kVAR	kilovolt ampere reactive	no., nos.	number, numbers	SN	serial number
kW	kilowatt	NPS	National Pipe, Straight	SPDT	single-pole, double-throw
kWh	kilowatt-hour	NPSC	National Pipe, Straight-coupling	SPST	single-pole, single-throw
kWm	kilowatt mechanical	NPT	National Standard taper pipe thread per general use	spec, specs	specification(s)
L	liter	NPTF	National Pipe, Taper-Fine	sq.	square
LAN	local area network	NR	not required, normal relay	sq. cm	square centimeter
L x W x H	length by width by height	ns	nanosecond	sq. in.	square inch
lb.	pound, pounds	OC	overcrank	SS	stainless steel
lbm/ft ³	pounds mass per cubic feet	OD	outside diameter	std.	standard
LCB	line circuit breaker	OEM	original equipment manufacturer	stl.	steel
LCD	liquid crystal display	OF	overfrequency	tach.	tachometer
ld. shd.	load shed	opt.	option, optional	TD	time delay
LED	light emitting diode	OS	oversize, overspeed	TDC	top dead center
Lph	liters per hour	OSHA	Occupational Safety and Health Administration	TDEC	time delay engine cooldown
Lpm	liters per minute	OV	overvoltage	TDEN	time delay emergency to normal
LOP	low oil pressure	oz.	ounce	TDES	time delay engine start
LP	liquefied petroleum	p., pp.	page, pages	TDNE	time delay normal to emergency
LPG	liquefied petroleum gas	PC	personal computer	TDOE	time delay off to emergency
LS	left side	PCB	printed circuit board	TDON	time delay off to normal
L _{wa}	sound power level, A weighted	pF	picofarad	temp.	temperature
LWL	low water level	PF	power factor	term.	terminal
LWT	low water temperature	ph., ∅	phase	TIF	telephone influence factor
m	meter, milli (1/1000)	PHC	Phillips head crimplite (screw)	TIR	total indicator reading
M	mega (10 ⁶ when used with SI units), male	PHH	Phillips hex head (screw)	tol.	tolerance
m ³	cubic meter	PHM	pan head machine (screw)	turbo.	turbocharger
m ³ /min.	cubic meters per minute	PLC	programmable logic control	typ.	typical (same in multiple locations)
mA	milliampere	PMG	permanent-magnet generator	UF	underfrequency
man.	manual	pot	potentiometer, potential	UHF	ultrahigh frequency
max.	maximum	ppm	parts per million	UL	Underwriter's Laboratories, Inc.
MB	megabyte (2 ²⁰ bytes)	PROM	programmable read-only memory	UNC	unified coarse thread (was NC)
MCM	one thousand circular mils	psi	pounds per square inch	UNF	unified fine thread (was NF)
MCCB	molded-case circuit breaker	pt.	pint	univ.	universal
meggar	megohmmeter	PTC	positive temperature coefficient	US	undersize, underspeed
MHz	megahertz	PTO	power takeoff	UV	ultraviolet, undervoltage
mi.	mile	PVC	polyvinyl chloride	V	volt
mil	one one-thousandth of an inch	qt.	quart, quarts	VAC	volts alternating current
min.	minimum, minute	qty.	quantity	VAR	voltampere reactive
misc.	miscellaneous	R	replacement (emergency) power source	VDC	volts direct current
MJ	megajoule	rad.	radiator, radius	VFD	vacuum fluorescent display
mJ	millijoule	RAM	random access memory	VGA	video graphics adapter
mm	millimeter	RDO	relay driver output	VHF	very high frequency
mOhm, mΩ	milliohm	ref.	reference	W	watt
MOhm, MΩ	megohm	rem.	remote	WCR	withstand and closing rating
MOV	metal oxide varistor	Res/Coml	Residential/Commercial	w/	with
MPa	megapascal	RFI	radio frequency interference	w/o	without
mpg	miles per gallon	RH	round head	wt.	weight
mph	miles per hour			xfmr	transformer
MS	military standard				
m/sec.	meters per second				

Appendix B Common Hardware Application Guidelines

Use the information below and on the following pages to identify proper fastening techniques when no specific reference for reassembly is made.

Bolt/Screw Length: When bolt/screw length is not given, use Figure 1 as a guide. As a general rule, a minimum length of one thread beyond the nut and a maximum length of 1/2 the bolt/screw diameter beyond the nut is the preferred method.

Washers and Nuts: Use split lock washers as a bolt locking device where specified. Use SAE flat washers with whiz nuts, spirallock nuts, or standard nuts and preloading (torque) of the bolt in all other applications.

See Appendix C, General Torque Specifications, and other torque specifications in the service literature.

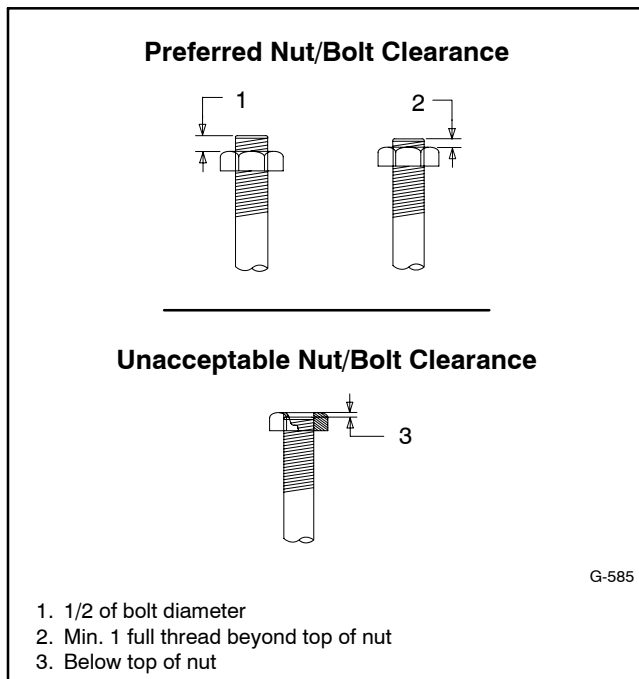

Figure 1 Acceptable Bolt Lengths

Steps for common hardware application:

1. Determine entry hole type: round or slotted.
2. Determine exit hole type: fixed female thread (weld nut), round, or slotted.

For round and slotted exit holes, determine if hardware is greater than 1/2 inch in diameter, or 1/2 inch in diameter or less. Hardware that is *greater than 1/2 inch* in diameter takes a standard nut and SAE washer. Hardware *1/2 inch or less* in diameter can take a properly torqued whiz nut or spirallock nut. See Figure 2.

3. Follow these SAE washer rules after determining exit hole type:
 - a. Always use a washer between hardware and a slot.
 - b. Always use a washer under a nut (see 2 above for exception).
 - c. Use a washer under a bolt when the female thread is fixed (weld nut).
4. Refer to Figure 2, which depicts the preceding hardware configuration possibilities.

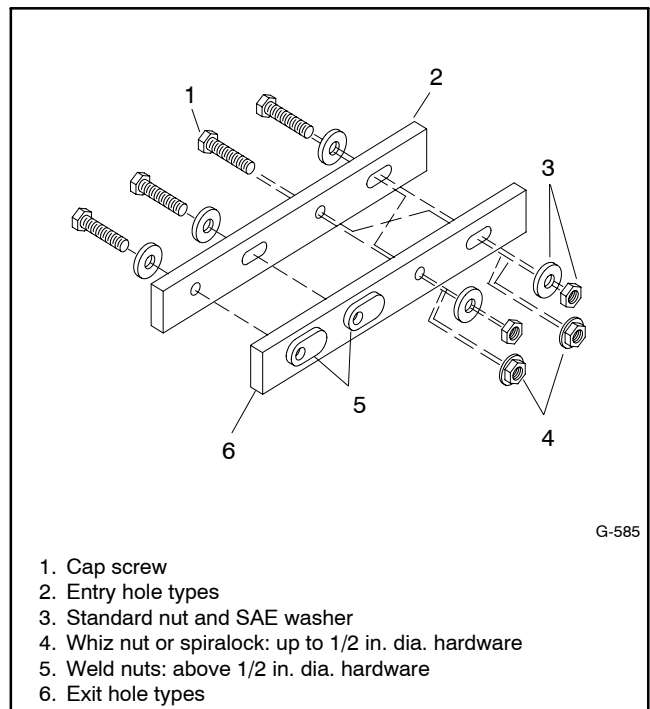

Figure 2 Acceptable Hardware Combinations

Appendix C General Torque Specifications















American Standard Fasteners Torque Specifications					
Size	Torque Measurement	Assembled into Cast Iron or Steel			Assembled into Aluminum Grade 2 or 5
		Grade 2	Grade 5	Grade 8	
8-32	Nm (in. lb.)	1.8 (16)	2.3 (20)	—	See Note 3
10-24	Nm (in. lb.)	2.9 (26)	3.6 (32)	—	
10-32	Nm (in. lb.)	2.9 (26)	3.6 (32)	—	
1/4-20	Nm (in. lb.)	6.8 (60)	10.8 (96)	14.9 (132)	
1/4-28	Nm (in. lb.)	8.1 (72)	12.2 (108)	16.3 (144)	
5/16-18	Nm (in. lb.)	13.6 (120)	21.7 (192)	29.8 (264)	
5/16-24	Nm (in. lb.)	14.9 (132)	23.1 (204)	32.5 (288)	
3/8-16	Nm (ft. lb.)	24.0 (18)	38.0 (28)	53.0 (39)	
3/8-24	Nm (ft. lb.)	27.0 (20)	42.0 (31)	60.0 (44)	
7/16-14	Nm (ft. lb.)	39.0 (29)	60.0 (44)	85.0 (63)	
7/16-20	Nm (ft. lb.)	43.0 (32)	68.0 (50)	95.0 (70)	
1/2-13	Nm (ft. lb.)	60.0 (44)	92.0 (68)	130.0 (96)	
1/2-20	Nm (ft. lb.)	66.0 (49)	103.0 (76)	146.0 (108)	
9/16-12	Nm (ft. lb.)	81.0 (60)	133.0 (98)	187.0 (138)	
9/16-18	Nm (ft. lb.)	91.0 (67)	148.0 (109)	209.0 (154)	
5/8-11	Nm (ft. lb.)	113.0 (83)	183.0 (135)	259.0 (191)	
5/8-18	Nm (ft. lb.)	128.0 (94)	208.0 (153)	293.0 (216)	
3/4-10	Nm (ft. lb.)	199.0 (147)	325.0 (240)	458.0 (338)	
3/4-16	Nm (ft. lb.)	222.0 (164)	363.0 (268)	513.0 (378)	
1-8	Nm (ft. lb.)	259.0 (191)	721.0 (532)	1109.0 (818)	
1-12	Nm (ft. lb.)	283.0 (209)	789.0 (582)	1214.0 (895)	











Metric Fasteners Torque Specifications, Measured in Nm (ft. lb.)				
Size (mm)	Assembled into Cast Iron or Steel			Assembled into Aluminum Grade 5.8 or 8.8
	Grade 5.8	Grade 8.8	Grade 10.9	
M6 x 1.00	6.2 (4.6)	9.5 (7)	13.6 (10)	See Note 3
M8 x 1.25	15.0 (11)	23.0 (17)	33.0 (24)	
M8 x 1.00	16.0 (11)	24.0 (18)	34.0 (25)	
M10 x 1.50	30.0 (22)	45.0 (34)	65.0 (48)	
M10 x 1.25	31.0 (23)	47.0 (35)	68.0 (50)	
M12 x 1.75	53.0 (39)	80.0 (59)	115.0 (85)	
M12 x 1.50	56.0 (41)	85.0 (63)	122.0 (90)	
M14 x 2.00	83.0 (61)	126.0 (93)	180.0 (133)	
M14 x 1.50	87.0 (64)	133.0 (98)	190.0 (140)	
M16 x 2.00	127.0 (94)	194.0 (143)	278.0 (205)	
M16 x 1.50	132.0 (97)	201.0 (148)	287.0 (212)	
M18 x 2.50	179.0 (132)	273.0 (201)	390.0 (288)	
M18 x 1.50	189.0 (140)	289.0 (213)	413.0 (305)	





Notes:

1. The torque values above are general guidelines. Always use the torque values specified in the service manuals and/or assembly drawings when they differ from the above torque values.
2. The torque values above are based on new plated threads. Increase torque values by 15% if non-plated threads are used.
3. Hardware threaded into aluminum must have either two diameters of thread engagement or a 30% or more reduction in the torque to prevent stripped threads.
4. Torque values are calculated as equivalent stress loading on American hardware with an approximate preload of 90% of the yield strength and a friction coefficient of 0.125.

Appendix D Common Hardware Identification

Screw/Bolts/Studs	
Head Styles	
Hex Head or Machine Head	
Hex Head or Machine Head with Washer	
Flat Head (FHM)	
Round Head (RHM)	
Pan Head	
Hex Socket Head Cap or Allen™ Head Cap	
Hex Socket Head or Allen™ Head Shoulder Bolt	
Sheet Metal Screw	
Stud	
Drive Styles	
Hex	
Hex and Slotted	
Phillips®	
Slotted	
Hex Socket	

Nuts	
Nut Styles	
Hex Head	
Lock or Elastic	
Square	
Cap or Acorn	
Wing	
Washers	
Washer Styles	
Plain	
Split Lock or Spring	
Spring or Wave	
External Tooth Lock	
Internal Tooth Lock	
Internal-External Tooth Lock	

Hardness Grades	
American Standard	
Grade 2	
Grade 5	
Grade 8	
Grade 8/9 (Hex Socket Head)	
Metric	
Number stamped on hardware; 5.8 shown	

Allen™ head screw is a trademark of Holo-Krome Co.

Phillips® screw is a registered trademark of Phillips Screw Company.

Sample Dimensions

American Standard (Screws, Bolts, Studs, and Nuts)

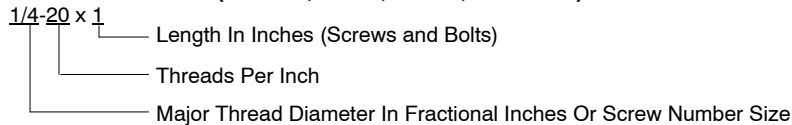

Metric (Screws, Bolts, Studs, and Nuts)

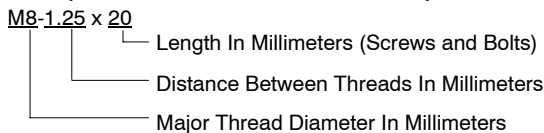

Plain Washers

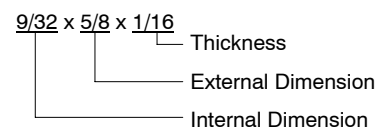

Lock Washers



Appendix E Common Hardware List

The Common Hardware List lists part numbers and dimensions for common hardware items.

American Standard

Part No.	Dimensions	Part No.	Dimensions	Part No.	Dimensions	Type		
Hex Head Bolts (Grade 5)			Hex Head Bolts, cont.			Hex Nuts		
X-465-17	1/4-20 x .38	X-6238-14	3/8-24 x .75	X-6009-1	1-8	Standard		
X-465-6	1/4-20 x .50	X-6238-16	3/8-24 x 1.25	X-6210-3	6-32	Whiz		
X-465-2	1/4-20 x .62	X-6238-21	3/8-24 x 4.00	X-6210-4	8-32	Whiz		
X-465-16	1/4-20 x .75	X-6238-22	3/8-24 x 4.50	X-6210-5	10-24	Whiz		
X-465-18	1/4-20 x .88			X-6210-1	10-32	Whiz		
X-465-7	1/4-20 x 1.00	X-6024-5	7/16-14 x .75					
X-465-8	1/4-20 x 1.25	X-6024-2	7/16-14 x 1.00	X-6210-2	1/4-20	Spiralock		
X-465-9	1/4-20 x 1.50	X-6024-8	7/16-14 x 1.25	X-6210-6	1/4-28	Spiralock		
X-465-10	1/4-20 x 1.75	X-6024-3	7/16-14 x 1.50	X-6210-7	5/16-18	Spiralock		
X-465-11	1/4-20 x 2.00	X-6024-4	7/16-14 x 2.00	X-6210-8	5/16-24	Spiralock		
X-465-12	1/4-20 x 2.25	X-6024-11	7/16-14 x 2.75	X-6210-9	3/8-16	Spiralock		
X-465-14	1/4-20 x 2.75	X-6024-12	7/16-14 x 6.50	X-6210-10	3/8-24	Spiralock		
X-465-21	1/4-20 x 5.00	X-129-15	1/2-13 x .75	X-6210-11	7/16-14	Spiralock		
X-465-25	1/4-28 x .38	X-129-17	1/2-13 x 1.00	X-6210-12	1/2-13	Spiralock		
X-465-20	1/4-28 x 1.00	X-129-18	1/2-13 x 1.25	X-6210-15	7/16-20	Spiralock		
		X-129-19	1/2-13 x 1.50	X-6210-14	1/2-20	Spiralock		
X-125-33	5/16-18 x .50	X-129-20	1/2-13 x 1.75					
X-125-23	5/16-18 x .62	X-129-21	1/2-13 x 2.00	X-85-3	5/8-11	Standard		
X-125-3	5/16-18 x .75	X-129-22	1/2-13 x 2.25	X-88-12	3/4-10	Standard		
X-125-31	5/16-18 x .88	X-129-23	1/2-13 x 2.50	X-89-2	1/2-20	Standard		
X-125-5	5/16-18 x 1.00	X-129-24	1/2-13 x 2.75					
X-125-24	5/16-18 x 1.25	X-129-25	1/2-13 x 3.00	Washers				
X-125-34	5/16-18 x 1.50	X-129-27	1/2-13 x 3.50	Part No.	ID	OD	Thick.	Bolt/ Screw
X-125-25	5/16-18 x 1.75	X-129-29	1/2-13 x 4.00	X-25-46	.125	.250	.022	#4
X-125-26	5/16-18 x 2.00	X-129-30	1/2-13 x 4.50	X-25-9	.156	.375	.049	#6
230578	5/16-18 x 2.25	X-463-9	1/2-13 x 5.50	X-25-48	.188	.438	.049	#8
X-125-29	5/16-18 x 2.50	X-129-44	1/2-13 x 6.00	X-25-36	.219	.500	.049	#10
X-125-27	5/16-18 x 2.75			X-25-40	.281	.625	.065	1/4
X-125-28	5/16-18 x 3.00	X-129-51	1/2-20 x .75	X-25-85	.344	.687	.065	5/16
X-125-22	5/16-18 x 4.50	X-129-45	1/2-20 x 1.25	X-25-37	.406	.812	.065	3/8
X-125-32	5/16-18 x 5.00	X-129-52	1/2-20 x 1.50	X-25-34	.469	.922	.065	7/16
X-125-35	5/16-18 x 5.50			X-25-26	.531	1.062	.095	1/2
X-125-36	5/16-18 x 6.00	X-6021-3	5/8-11 x 1.00	X-25-15	.656	1.312	.095	5/8
X-125-40	5/16-18 x 6.50	X-6021-4	5/8-11 x 1.25	X-25-29	.812	1.469	.134	3/4
		X-6021-2	5/8-11 x 1.50	X-25-127	1.062	2.000	.134	1
X-125-43	5/16-24 x 1.75	X-6021-1	5/8-11 x 1.75					
X-125-44	5/16-24 x 2.50	273049	5/8-11 x 2.00					
X-125-30	5/16-24 x .75	X-6021-5	5/8-11 x 2.25					
X-125-39	5/16-24 x 2.00	X-6021-6	5/8-11 x 2.50					
X-125-38	5/16-24 x 2.75	X-6021-7	5/8-11 x 2.75					
		X-6021-12	5/8-11 x 3.75					
X-6238-2	3/8-16 x .62	X-6021-11	5/8-11 x 4.50					
X-6238-10	3/8-16 x .75	X-6021-10	5/8-11 x 6.00					
X-6238-3	3/8-16 x .88							
X-6238-11	3/8-16 x 1.00	X-6021-9	5/8-18 x 2.50					
X-6238-4	3/8-16 x 1.25							
X-6238-5	3/8-16 x 1.50	X-6239-1	3/4-10 x 1.00					
X-6238-1	3/8-16 x 1.75	X-6239-8	3/4-10 x 1.25					
X-6238-6	3/8-16 x 2.00	X-6239-2	3/4-10 x 1.50					
X-6238-17	3/8-16 x 2.25	X-6239-3	3/4-10 x 2.00					
X-6238-7	3/8-16 x 2.50	X-6239-4	3/4-10 x 2.50					
X-6238-8	3/8-16 x 2.75	X-6239-5	3/4-10 x 3.00					
X-6238-9	3/8-16 x 3.00	X-6239-6	3/4-10 x 3.50					
X-6238-19	3/8-16 x 3.25							
X-6238-12	3/8-16 x 3.50	X-792-1	1-8 x 2.25					
X-6238-20	3/8-16 x 3.75	X-792-5	1-8 x 3.00					
X-6238-13	3/8-16 x 4.50	X-792-8	1-8 x 5.00					
X-6238-18	3/8-16 x 5.50							
X-6238-25	3/8-16 x 6.50							

Metric

Hex head bolts are hardness grade 8.8 unless noted.

Part No.	Dimensions	Part No.	Dimensions	Part No.	Dimensions
Hex Head Bolts (Partial Thread)					
M931-05055-60	M5-0.80 x 55	Hex Head Bolts (Partial Thread), continued		Hex Head Bolts (Full Thread), continued	
M931-06040-60	M6-1.00 x 40	M960-16090-60	M16-1.50 x 90	M933-12016-60	M12-1.75 x 16
M931-06055-60	M6-1.00 x 55	M931-16090-60	M16-2.00 x 90	M933-12020-60	M12-1.75 x 20
M931-06060-60	M6-1.00 x 60	M931-16100-60	M16-2.00 x 100	M961-12020-60F	M12-1.50 x 20
M931-06060-SS	M6-1.00 x 60	M931-16100-82	M16-2.00 x 100*	M933-12025-60	M12-1.75 x 25
M931-06070-60	M6-1.00 x 70	M931-16120-60	M16-2.00 x 120	M933-12025-82	M12-1.75 x 25*
M931-06070-SS	M6-1.00 x 70	M931-16150-60	M16-2.00 x 150	M961-12030-60	M12-1.25 x 30
M931-06075-60	M6-1.00 x 75			M933-12030-82	M12-1.75 x 30*
M931-06090-60	M6-1.00 x 90	M931-20065-60	M20-2.50 x 65	M961-12030-82F	M12-1.50 x 30*
M931-06145-60	M6-1.00 x 145	M931-20090-60	M20-2.50 x 90	M933-12030-60	M12-1.75 x 30
M931-06150-60	M6-1.00 x 150	M931-20100-60	M20-2.50 x 100	M933-12035-60	M12-1.75 x 35
		M931-20120-60	M20-2.50 x 120	M961-12040-82	M12-1.25 x 40*
M931-08035-60	M8-1.25 x 35	M931-20140-60	M20-2.50 x 140	M933-12040-60	M12-1.75 x 40
M931-08040-60	M8-1.25 x 40	M931-20160-60	M20-2.50 x 160	M933-12040-82	M12-1.75 x 40*
M931-08045-60	M8-1.25 x 45				
M931-08050-60	M8-1.25 x 50	M931-22090-60	M22-2.50 x 90	M961-14025-60	M14-1.50 x 25
M931-08055-60	M8-1.25 x 55	M931-22120-60	M22-2.50 x 120	M933-14025-60	M14-2.00 x 25
M931-08055-82	M8-1.25 x 55*	M931-22160-60	M22-2.50 x 160	M961-14050-82	M14-1.50 x 50*
M931-08060-60	M8-1.25 x 60				
M931-08070-60	M8-1.25 x 70	M931-24090-60	M24-3.00 x 90	M961-16025-60	M16-1.50 x 25
M931-08070-82	M8-1.25 x 70*	M931-24120-60	M24-3.00 x 120	M933-16025-60	M16-2.00 x 25
M931-08075-60	M8-1.25 x 75	M931-24160-60	M24-3.00 x 160	M961-16030-82	M16-1.50 x 30*
M931-08080-60	M8-1.25 x 80	M931-24200-60	M24-3.00 x 200	M933-16030-82	M16-2.00 x 30*
M931-08090-60	M8-1.25 x 90			M933-16035-60	M16-2.00 x 35
M931-08095-60	M8-1.25 x 95	Hex Head Bolts (Full Thread)			
M931-08100-60	M8-1.25 x 100	M933-04006-60	M4-0.70 x 6	M961-16040-60	M16-1.50 x 40
M931-08110-60	M8-1.25 x 110			M933-16040-60	M16-2.00 x 40
M931-08120-60	M8-1.25 x 120	M933-05030-60	M5-0.80 x 30	M961-16045-82	M16-1.50 x 45*
M931-08130-60	M8-1.25 x 130	M933-05035-60	M5-0.80 x 35	M933-16045-82	M16-2.00 x 45*
M931-08140-60	M8-1.25 x 140	M933-05050-60	M5-0.80 x 50	M933-16050-60	M16-2.00 x 50
M931-08150-60	M8-1.25 x 150			M933-16050-82	M16-2.00 x 50*
M931-08200-60	M8-1.25 x 200	M933-06010-60	M6-1.00 x 10	M933-16060-60	M16-2.00 x 60
		M933-06012-60	M6-1.00 x 12	M933-16070-60	M16-2.00 x 70
M931-10040-82	M10-1.25 x 40*	M933-06014-60	M6-1.00 x 14		
M931-10040-60	M10-1.50 x 40	M933-06016-60	M6-1.00 x 16	M933-18035-60	M18-2.50 x 35
M931-10045-60	M10-1.50 x 45	M933-06020-60	M6-1.00 x 20	M933-18050-60	M18-2.50 x 50
M931-10050-60	M10-1.50 x 50	M933-06025-60	M6-1.00 x 25	M933-18060-60	M18-2.50 x 60
M931-10050-82	M10-1.25 x 50*	M933-06030-60	M6-1.00 x 30		
M931-10055-60	M10-1.50 x 55	M933-06040-60	M6-1.00 x 40	M933-20050-60	M20-2.50 x 50
M931-10060-60	M10-1.50 x 60	M933-06050-60	M6-1.00 x 50	M933-20055-60	M20-2.50 x 55
M931-10065-60	M10-1.50 x 65				
M931-10070-60	M10-1.50 x 70	M933-07025-60	M7-1.00 x 25	M933-24060-60	M24-3.00 x 60
M931-10080-60	M10-1.50 x 80			M933-24065-60	M24-3.00 x 65
M931-10080-82	M10-1.25 x 80*	M933-08010-60	M8-1.25 x 10	M933-24070-60	M24-3.00 x 70
M931-10090-60	M10-1.50 x 90	M933-08012-60	M8-1.25 x 12		
M931-10090-82	M10-1.50 x 90*	M933-08016-60	M8-1.25 x 16	Pan Head Machine Screws	
M931-10100-60	M10-1.50 x 100	M933-08020-60	M8-1.25 x 20	M7985A-03010-20	M3-0.50 x 10
M931-10110-60	M10-1.50 x 110	M933-08025-60	M8-1.25 x 25	M7985A-03012-20	M3-0.50 x 12
M931-10120-60	M10-1.50 x 120	M933-08030-60	M8-1.25 x 30	M7985A-04010-20	M4-0.70 x 10
M931-10130-60	M10-1.50 x 130	M933-08030-82	M8-1.25 x 30*	M7985A-04016-20	M4-0.70 x 16
M931-10140-60	M10-1.50 x 140			M7985A-04020-20	M4-0.70 x 20
M931-10180-60	M10-1.50 x 180	M933-10012-60	M10-1.50 x 12	M7985A-04050-20	M4-0.70 x 50
M931-10235-60	M10-1.50 x 235	M961-10020-60	M10-1.25 x 20	M7985A-04100-20	M4-0.70 x 100
M931-10260-60	M10-1.50 x 260	M933-10020-60	M10-1.50 x 20		
M960-10330-60	M10-1.25 x 330	M933-10025-60	M10-1.50 x 25	M7985A-05010-20	M5-0.80 x 10
		M961-10025-60	M10-1.25 x 25	M7985A-05012-20	M5-0.80 x 12
M931-12045-60	M12-1.75 x 45	M933-10025-82	M10-1.50 x 25*	M7985A-05016-20	M5-0.80 x 16
M960-12050-60	M12-1.25 x 50	M961-10030-60	M10-1.25 x 30	M7985A-05020-20	M5-0.80 x 20
M960-12050-82	M12-1.25 x 50*	M933-10030-60	M10-1.50 x 30	M7985A-05025-20	M5-0.80 x 25
M931-12050-60	M12-1.75 x 50	M933-10030-82	M10-1.50 x 30*	M7985A-05030-20	M5-0.80 x 30
M931-12050-82	M12-1.75 x 50*	M961-10035-60	M10-1.25 x 35	M7985A-05080-20	M5-0.80 x 80
M931-12055-60	M12-1.75 x 55	M933-10035-60	M10-1.50 x 35	M7985A-05100-20	M5-0.80 x 100
M931-12060-60	M12-1.75 x 60	M933-10035-82	M10-1.50 x 35*		
M931-12060-82	M12-1.75 x 60*	M961-10040-60	M10-1.25 x 40	M7985A-06100-20	M6-1.00 x 100
M931-12065-60	M12-1.75 x 65				
M931-12075-60	M12-1.75 x 75			Flat Head Machine Screws	
M931-12080-60	M12-1.75 x 80			M965A-04012-SS	M4-0.70 x 12
M931-12090-60	M12-1.75 x 90				
M931-12100-60	M12-1.75 x 100			M965A-05012-SS	M5-0.80 x 12
M931-12110-60	M12-1.75 x 110			M965A-05016-20	M5-0.80 x 16
				M965A-06012-20	M6-1.00 x 12

* This metric hex bolt's hardness is grade 10.9.

Metric, continued

Part No.	Dimensions	Type
Hex Nuts		
M934-03-50	M3-0.50	Standard
M934-04-50	M4-0.70	Standard
M934-04-B	M4-0.70	Brass
M934-05-50	M5-0.80	Standard
M934-06-60	M6-1.00	Standard
M934-06-64	M6-1.00	Std. (green)
M6923-06-80	M6-1.00	Spirallock
M982-06-80	M6-1.00	Elastic Stop
M934-08-60	M8-1.25	Standard
M6923-08-80	M8-1.25	Spirallock
M982-08-80	M8-1.25	Elastic Stop
M934-10-60	M10-1.50	Standard
M934-10-60F	M10-1.25	Standard
M6923-10-80	M10-1.50	Spirallock
M6923-10-62	M10-1.50	Spirallock†
M982-10-80	M10-1.50	Elastic Stop
M934-12-60	M12-1.75	Standard
M934-12-60F	M12-1.25	Standard
M6923-12-80	M12-1.75	Spirallock
M982-12-80	M12-1.75	Elastic Stop
M982-14-60	M14-2.00	Elastic Stop
M6923-16-80	M16-2.00	Spirallock
M982-16-80	M16-2.00	Elastic Stop
M934-18-80	M18-2.5	Standard
M982-18-60	M18-2.50	Elastic Stop
M934-20-80	M20-2.50	Standard
M982-20-80	M20-2.50	Elastic Stop
M934-22-60	M22-2.50	Standard
M934-24-80	M24-3.00	Standard
M982-24-60	M24-3.00	Elastic Stop
M934-30-80	M30-3.50	Standard

Washers

Part No.	ID	OD	Thick.	Bolt/ Screw
M125A-03-80	3.2	7.0	0.5	M3
M125A-04-80	4.3	9.0	0.8	M4
M125A-05-80	5.3	10.0	1.0	M5
M125A-06-80	6.4	12.0	1.6	M6
M125A-08-80	8.4	16.0	1.6	M8
M125A-10-80	10.5	20.0	2.0	M10
M125A-12-80	13.0	24.0	2.5	M12
M125A-14-80	15.0	28.0	2.5	M14
M125A-16-80	17.0	30.0	3.0	M16
M125A-18-80	19.0	34.0	3.0	M18
M125A-20-80	21.0	37.0	3.0	M20
M125A-24-80	25.0	44.0	4.0	M24

† This metric hex nut's hardness is grade 8.

TP-6346 12/05

© 2005 by Kohler Co. All rights reserved.

KOHLER[®] POWER SYSTEMS

KOHLER CO. Kohler, Wisconsin 53044
Phone 920-565-3381, Fax 920-459-1646
For the nearest sales/service outlet in the
US and Canada, phone 1-800-544-2444
KohlerPowerSystems.com

Kohler Power Systems
Asia Pacific Headquarters
7 Jurong Pier Road
Singapore 619159
Phone (65) 6264-6422, Fax (65) 6264-6455