

**AVTRON MODEL K711  
LOAD BANK, RESISTIVE, DUCT MOUNT  
Serial Number 3118 and Above**

© 2004 Avtron Loadbank, Inc.  
Cleveland, Ohio

December 29, 2004  
Rev. July 9, 2009

WHEN ORDERING SERVICE OR  
REPAIR PARTS, PLEASE SPECIFY  
MODEL NO. AND/OR PART NO.  
LOCATED ON NAMEPLATE AND  
DWG. NO. A37486.



APPLICATION		REVISION			
MODEL/PART NO. MODIFIED	ECN	LTR	DESCRIPTION	DATE	APPROVAL
K711480-P-86-84-G4H-G,K					

## PARTS NOT REQUIRED

PART NO.	QTY	ASSEMBLY	DESCRIPTION	DISP	REF DESIG
B22519-50	24 REF	TOP	ROD, ELEMENT SUPPORT	2	
A21179	48 REF	TOP	SUPPORT ROD BUSHING	2	
411141	576 REF	TOP	TUBE, INSULATOR	2	
411145	24 REF	TOP	TUBE, INSULATOR	2	
411181	48 REF	TOP	INSULATOR	2	
411182	96 REF	TOP	INSULATOR	2	
602050	24 REF	TOP	BUSLINK	2	
606337	96 REF	TOP	RESISTIVE ELEMENT	2	
B14796	16 REF	TOP	RELAY	2	K2-5 (A-D)
324420	48 REF	TOP	FUSE, 80 AMP, 600V	2	F6-18 (A-D)
324967	3 REF	TOP	FUSEBLOCK	2	

## NEW PARTS REQUIRED

PART NO.	QTY	ASSEMBLY	DESCRIPTION	DISP	REF DESIG
A24032	1	TOP	NAMEPLATE		
A24721	72 REF	TOP	RESISTIVE ELEMENT		
B16690	12 REF	TOP	RELAY		K2-5 (A-C)
324422	36 REF	TOP	FUSE, 100 AMP, 600V		F4-18 (A-C)
D47435	1 REF	TOP	COVER, CONTROL PANEL		
322186	1 REF	TOP	FAN, 115 VAC		B1
B15869	2 REF	TOP	LABEL, WARNING		

### DISPOSITION

- 1) RETURN TO VENDOR
- 2) RETURN TO STOCK
- 3) SCRAP
- 4) RETURN TO SURPLUS

### NEW DRAWINGS

D47435

---



---



---



---

PROJECT 245986

WIRING DIAGRAMS AFFECTED \_\_\_\_\_

SCHEMATICS AFFECTED C21408

---



---



---

THIS DOCUMENT CONTAINS PROPRIETARY INFORMATION OF AVTRON AND MAY NOT BE DISCLOSED TO OTHERS OR USED FOR MANUFACTURING PURPOSES WITHOUT THE WRITTEN CONSENT OF AVTRON.

DRAWN	R.RAYNER	DATE	1/19/10
ENG MGR	C.KULBAGO	DATE	1/19/10
APP'D PROD	D.JANICKI	DATE	1/20/10



TITLE MODIFICATION, 900KW, 480VAC, REDUCED ELEMENTS, VENTED ENCL.

CAGE NO.	SIZE	DRAWING NO.	SH	OF	REV
01014	A	A37486	1	5	



APPLICATION		REVISION			
MODEL/PART NO. MODIFIED	ECN	LTR	DESCRIPTION	DATE	APPROVAL
K711480-P-86-84-G4H-G,K					

## PARTS NOT REQUIRED

PART NO.	QTY	ASSEMBLY	DESCRIPTION	DISP	REF DESIG
C21391-86	1 REF	TOP	COVER, CONTROL PANEL	2	

## NEW PARTS REQUIRED

PART NO.	QTY	ASSEMBLY	DESCRIPTION	DISP	REF DESIG
324452	1 REF	TOP	FUSE, 2 AMP, 600V		F104
D37355	2 REF	TOP	DEFLECTOR, AIR		
432479	1 REF	TOP	FILTER, AIR		
D36737	1 REF	TOP	MOUNTING BRACKET		

**DISPOSITION**

- 1) RETURN TO VENDOR
- 2) RETURN TO STOCK
- 3) SCRAP
- 4) RETURN TO SURPLUS

**NEW DRAWINGS**

PROJECT 245986

WIRING DIAGRAMS AFFECTED \_\_\_\_\_

SCHEMATICS AFFECTED C21408

THIS DOCUMENT CONTAINS PROPRIETARY INFORMATION OF AVTRON AND MAY NOT BE DISCLOSED TO OTHERS OR USED FOR MANUFACTURING PURPOSES WITHOUT THE WRITTEN CONSENT OF AVTRON.

DRAWN	R.RAYNER	DATE	1/19/10
ENG MGR	C.KULBAGO	DATE	1/19/10
APP'D PROD	D.JANICKI	DATE	1/20/10



TITLE MODIFICATION, 900KW, 480VAC, REDUCED ELEMENTS, VENTED ENCL.					PSF
CAGE NO.	SIZE	DRAWING NO.	SH	OF	REV
01014	A	A37486	2	5	

APPLICATION		REVISION			
MODEL/PART NO. MODIFIED	ECN	LTR	DESCRIPTION	DATE	APPROVAL
K711480-P-86-84-G4H-G,K					

## MODIFICATION REQUIRED

COMPLETE NECESSARY MODIFICATION TO ACHIEVE UL FILE E140848 REQUIREMENTS FOR K711. LOAD BANK.

### INSTALLATION INSTRUCTIONS:

1. GENERATE COMPUTER PRINTED LABELS AND ATTACH ADJACENT TO EACH FUSEHOLDER THAT READS AS FOLLOWS:
  - A.) FOR FAN FUSE:
    - "CLASS CC, xxA, 600V FUSE"
    - (xxA = AMP RATING OF FUSE)

SCOPE: REDUCE THE TOTAL ELEMENT QUANTITY BY EIGHTEEN ELEMENTS. REPLACE THE (3) 200 KW STEPS CONSISTING OF FOUR 50 KW BLOCKS, WITH 3 STEPS CONSISTING OF THREE 66.7 KW BLOCKS.

### INSTALLATION INSTRUCTIONS:

1. DO NOT MOUNT ANY RELAYS OR FUSEBLOCKS IN THE TWO TOP LOCATIONS OF D24199-82. START WITH THE THIRD LOCATION FROM THE TOP.
2. ASSEMBLE AND WIRE THE LOAD BANK, EXCEPT FOR THE 200 KW LOAD STEPS, PER D36481 AND C21408. ASSEMBLE AND WIRE THE 200 KW LOAD STEPS PER THE FOLLOWING INSTRUCTIONS.
3. INSTALL THREE B16690 RELAYS, THREE 324967 FUSEBLOCKS, AND NINE 324422 FUSES (PER 200KW STEP).
4. WIRE THE RELAY COILS PER D36481.
5. INSTALL AND WIRE EIGHTEEN A24721 RESISTIVE ELEMENTS (PER 200KW STEP) PER C21408, 3 x FIGURE # 2, AND USE #4 AWG WIRE PN 390324 IN PLACE OF #6 AWG WIRE PN 390323.

THIS DOCUMENT CONTAINS PROPRIETARY INFORMATION OF AVTRON AND MAY NOT BE DISCLOSED TO OTHERS OR USED FOR MANUFACTURING PURPOSES WITHOUT THE WRITTEN CONSENT OF AVTRON.



TITLE MODIFICATION, 900KW, 480VAC, REDUCED ELEMENTS, VENTED ENCL.

CAGE NO.	SIZE	DRAWING NO.	SH	OF	REV
01014	A	A37486	3	5	

APPLICATION		REVISION			
MODEL/PART NO. MODIFIED	ECN	LTR	DESCRIPTION	DATE	APPROVAL
K711480-P-86-84-G4H-G,K					

## MODIFICATION REQUIRED

SCOPE: REPLACE CONTROL PANEL COVER WITH VENTILATED CONTROL PANEL COVER.  
 ASSEMBLY REQUIRED:

1. REPLACE C21391-86 WITH D47435.
2. MOUNT FAN, PN 322186 ONTO D47435 USING #8-32 SST HDW. MOUNT THE FAN WITH THE AIR BLOWING OUT OF THE LOAD BANK ENCLOSURE. LABEL AS "B1".
3. INSTALL F104 INTO FUSEBLOCK USED FOR F102 AND F103 OF THE CONTROL TRANSFORMER OPTION C21399.
4. INSTALL WARNING LABELS, PN B15869, TO INSIDE AND OUTSIDE OF D47435 APPROXIMATELY 2 INCHES BELOW B1.
5. WIRE THE FAN PER THE SCHEMATIC AS SHOWN BELOW; USE 18AWG, BLACK, PN 390005, UNLESS OTHERWISE NOTED.
6. LINE DRILL AND MOUNT DEFLECTOR (P/N D37355), MOUNTING BRACKET (P/N D36737) AND FILTER (P/N 432479), PER DRAWING ON PAGE 5, USE #8-32 SST HDW.
7. INSTALL NAMEPLATE PN A24032 ADJACENT TO EXISTING ID PLATE.
8. MODIFICATION COMPLETE.

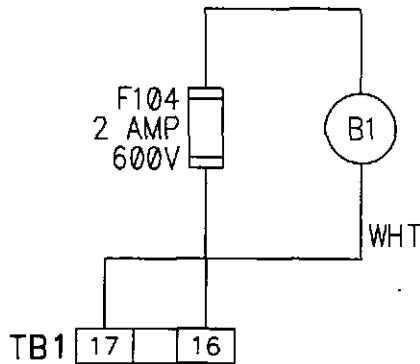

NOTE: WIRING FOR B1; ALL OTHER CONNECTIONS ARE SHOWN FOR REFERENCE.

THIS DOCUMENT CONTAINS PROPRIETARY INFORMATION OF AVTRON, INC. AND MAY NOT BE DISCLOSED TO OTHERS OR USED FOR MANUFACTURING PURPOSES WITHOUT THE WRITTEN CONSENT OF AVTRON.



TITLE MODIFICATION, 900KW, 480VAC, REDUCED ELEMENTS, VENTED ENCL.

CAGE NO. 01014	SIZE A	DRAWING NO. A37486	SH 4	OF 5	REV
-------------------	-----------	-----------------------	---------	---------	-----

APPLICATION		REVISION			
MODEL/PART NO. MODIFIED	ECN	LTR	DESCRIPTION	DATE	APPROVAL
K711480-P-86-84-G4H-G,K					

# MODIFICATION REQUIRED

SECURE FILTER WITH #10-24 x 1" LG SCREW (QTY 4)

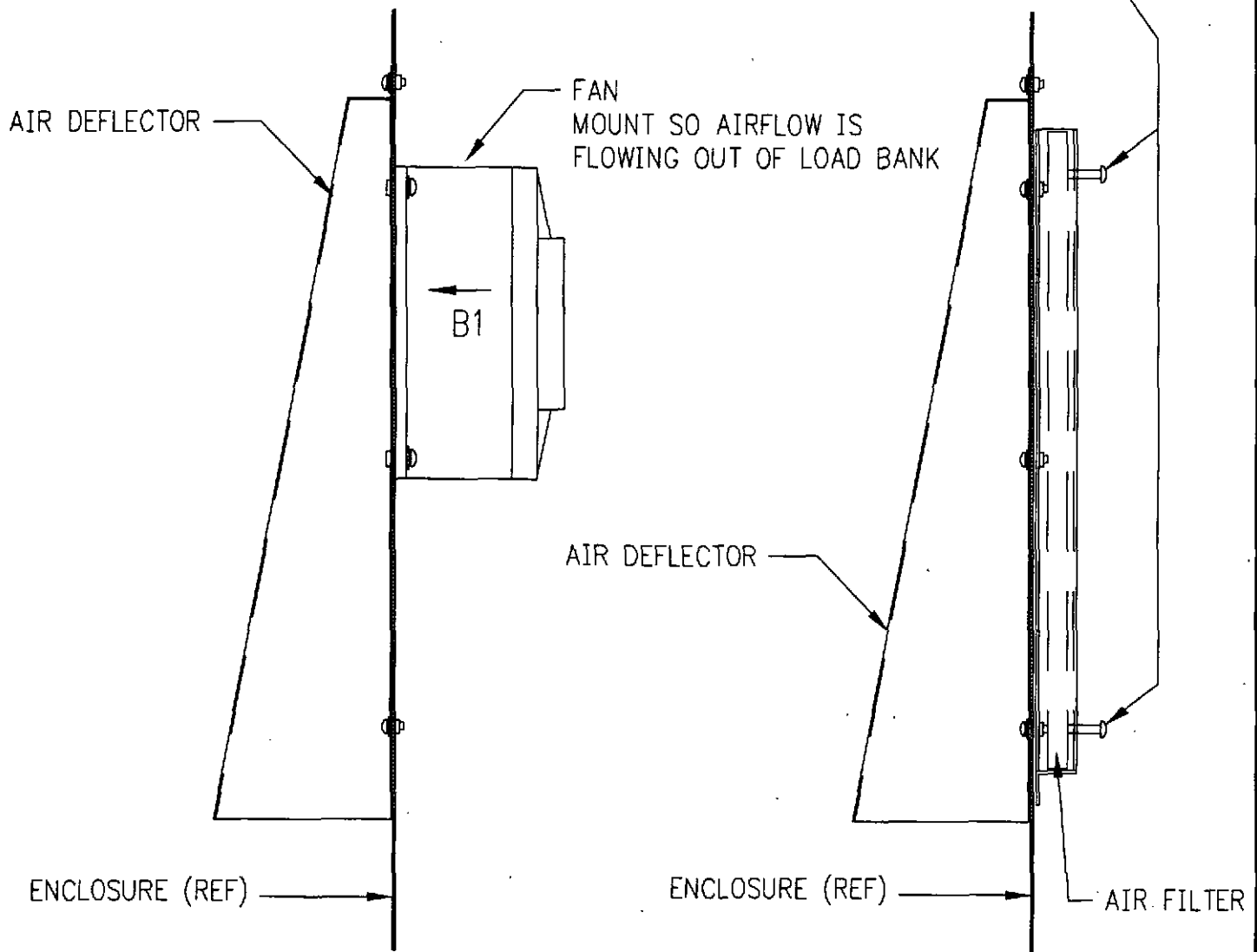

TOP DEFLECTOR  
SCALE: NONE

BOTTOM DEFLECTOR  
SCALE: NONE

THIS DOCUMENT CONTAINS PROPRIETARY INFORMATION OF AVTRON AND MAY NOT BE DISCLOSED TO OTHERS OR USED FOR MANUFACTURING PURPOSES WITHOUT THE WRITTEN CONSENT OF AVTRON.



TITLE MODIFICATION, 900KW, 480VAC, REDUCED ELEMENTS, VENTED ENCL.

CAGE NO. 01014	SIZE A	DRAWING NO. A37486	SH 5	OF 5	REV
-------------------	-----------	-----------------------	---------	---------	-----

## **PROPRIETARY NOTE**

This document contains information PROPRIETARY to Avtron, Inc. It is furnished solely to provide information sufficient for instruction, operation, maintenance, evaluation, and testing of the equipment herein disclosed; is not to be used for manufacturing or procurement; and is not to be disclosed to anyone other than persons in the Division, or the Company, or the Government, as the case may be, responsible for action relating to this document without the express written permission of Avtron, Inc.

## **WARRANTY**

The last page of this document contains an express limited warranty. The provisions of this warranty cover any and all rights extended to holders of Avtron equipment.

AVTRON MODEL K711  
LOAD BANK, RESISTIVE, DUCT MOUNT  
PROJECT NO. 245986

K711480 - 86 - 84 - G4H - G, K  
Modified Per A37486

**TABLE OF CONTENTS**

Section		Page
I	SAFETY CONSIDERATIONS . . . . .	1-1
II	DESCRIPTION AND SPECIFICATIONS . . . . .	2-1
III	INSTALLATION . . . . .	3-1
IV	OPERATION . . . . .	4-1

**Load Bank Rating:**

Total KW	900 KW
Operating Voltage	480 VAC
Phase	3 Phase
Frequency	60 Hz
Current	1,082.6 Amps
Minimum airflow required for full load operation	43,344 CFM

**Load Steps:**

One 100 KW, Four 200 KW, Load Steps

**Drawings:**

SB2203	Outline Drawing, Load Bank
C21408	Schematic/Wiring Diagram, Load Bank
D36481	Schematic/Wiring Diagram, (Controls)
C21397 THRU C21400	Options, Control Transformer

**Bulletins:**

202	Installation Notes, Engine Generator, Duct or Radiator Type
203	Sample Calculations, Engine Generator, Duct Type Load Banks

**SUPPLEMENTAL VENDOR MANUAL**

Electro Industries - SHARK100 CD-ROM(E145420) & Quick Start Guide(E145703)  
(Provided only when Option M or N is purchased)

### K711 Options List

These options are available for Avtron Model K711 Load Banks. Not all options can be installed in the same Load Bank. Installed options are marked on the identification tag.

<u>OPTION DWG. NO.</u>	<u>OPTION</u>	<u>DESCRIPTION</u>
C26165	A	Remote Control Panel
A20712*	B	Control Panel Enclosure
D36631-1	C	Load Shed, Two Step
D36631-2	D	Load Shed, Three Step
D36631-3	E	Load Shed, Four Step
D36631-4	F	Load Shed, Five Step
C21401	G	Outdoor Protection
C21397**	H	Control Transformer, 208:120V
C21398**	J	Control Transformer, 240:120V
C21399**	K	Control Transformer, 480:120V
C21400**	L	Control Transformer, 600:120V
D36494**	M	Digital Metering, Local
D36495**	N	Digital Metering, Remote

\* When Option B is installed in Load Bank, Outline Drawing SB1635 is included at the end of the manual to provide dimensional information.

\*\* When these options are installed in Load Bank, the drawing is provided at the end of the manual for electrical schematic wiring information.

K711 Options List (Cont.)

These options are available for Avtron Model K711 Load Banks. Not all options can be installed in the same Load Bank. Installed options are marked on the identification tag.

<u>OPTION DWG. NO.</u>	<u>OPTION</u>	<u>DESCRIPTION</u>
C22177-H	P	Controls on Exhaust Side of Load Bank
B29625***	Q	Control Panel/Meter Enclosure
D36492-1	R	Current Transformers for Metering, 100A
D36492-2	S	Current Transformers for Metering, 200A
D36492-3	T	Current Transformers for Metering, 400A
D36492-4	U	Current Transformers for Metering, 600A
D36492-5	V	Current Transformers for Metering, 800A
D36492-6	W	Current Transformers for Metering, 1000A
D36492-7	X	Current Transformers for Metering, 1200A

\*\*\* When Option Q is installed in Load Bank, Outline Drawing SB2196 is provided at the end of the manual for dimensional information.



## ESD PRECAUTIONARY GUIDELINES

### C A U T I O N

Certain circuit card assemblies and their components, typically integrated circuits, may be damaged by seemingly undetectable electrostatic discharge (ESD). Care must be exercised during handling/repair of these items. Use electrostatic discharge precautionary procedures.

The following guidelines are not necessarily all inclusive but rather serve as reminders for good shop practices for the handling/repair of ESD sensitive circuit card assemblies and devices.

- Store ESD sensitive items in their original containers. These items are often marked with the symbol shown at the top of this page.
- Put on a grounded wrist strap before handling any ESD sensitive item.
- Clear work area of Styrofoam®, plastic, and vinyl items such as coffee cups.
- Handle ESD items by the body, never the open edge connectors.
- Never slide ESD sensitive items over any surface.
- Transport ESD sensitive items in a static shielding container to a static-free work station.
- If a static-free work station is not available, ground the transport container before removing or inserting an ESD item.
- Electric tools used during repair should be grounded. For example, use only anti-static type solder suckers and grounded tip soldering irons. Discharge non-electric tools before use.
- Pack ESD items in static shielding containers before shipping them to Avtron for repair.

\* Styrofoam® is a registered trademark of Dow Chemical.

AVTRON MODEL K711  
LOAD BANK, RESISTIVE, DUCT MOUNT  
Serial Number 3118 and Above

**SECTION I**

**SAFETY CONSIDERATIONS**

Throughout this manual, you will find **WARNING** and **CAUTION** statements. Personal injury to an operator using or repairing the equipment may occur if a **WARNING** statement is ignored. Damage to the equipment and potentially hazardous conditions for personnel may occur if a **CAUTION** statement is ignored.

Each Avtron unit is safety checked for opens and shorts, and the insulation is high potential tested to ensure safe operation. All fuses, safety interlocks, and related safety equipment have been proven reliable as part of the testing procedure of each unit.

As part of your safety program, an initial inspection after receiving the unit(s) and periodic preventive maintenance and safety inspections should be conducted to ensure the reliability and safety built into your Avtron equipment.

The Model K711 Load Bank is an industrial test unit designed to be used indoors safely. However, because of the nature of the Load Bank function (the dissipation of electrical energy), there are inherent dangers to operators and equipment. These dangers are outlined in this section.

The Model K711 Load Bank is designed to be mounted on a duct or on the exhaust side of the radiator of an engine-driven generator set. The Load Bank resistors rely on the exhaust air from the radiator fan for cooling.

At design airflow velocities, the Load Bank exhaust air can reach an average 150°F over ambient with localized parcels of air reaching up to 300°F over ambient. All components of the exhaust air system must be able to handle this high temperature. There can be no combustible or heat sensitive devices or equipment inside or near the exhaust duct, including but not limited to the exhaust louvers and/or shutters.

For supplemental information, refer to Bulletins 202 and 203.

Electrical energy is transformed into heat by the resistors. This heat must be removed from the Load Bank by the cooling blower (not part of Load Bank). If there is any restriction or stoppage of airflow, the Load Bank may overheat and may even start a fire. It is recommended that:

1. The operator should read the manual before using the Load Bank.
2. Run an approved ground wire from the Load Bank ground lug, located inside the load connection area to the generator frame. Run an approved ground wire from the generator frame to a good earth ground.
3. Your unit is equipped with a temperature switch in the load element area. Do not bypass the temperature switch to prevent nuisance tripping. The switch drops out load if insufficient air is reaching the load elements.
4. If the unit is to be installed within existing duct work, leave enough access area to easily remove access covers on each side of the Load Bank. Special consideration should be given to mounting surface material, duct and devices in close proximity due to hot air exhaust.
5. Connections to ducts must be watertight in outdoor applications.
6. Maintenance personnel must always exercise caution when the access panels are removed. Personal injury from electrical shock may result if all sources of power are not disconnected before servicing. Maintenance work must be done only by qualified personnel.
7. Adequate airflow in cubic ft./min. (CFM) must be maintained at all times. (Refer to the DESCRIPTION section for minimum value of required airflow.) Failure to maintain this airflow evenly across the resistor elements may result in element burnout. Indoor and enclosed units may require supplemental cooling air. Full load thermal testing should be conducted on initial run at maximum ambient to verify no cooling/thermal problems exist.
8. If duct work is vented through a screened exhaust or louvered exhaust, ensure that the louvers (if motorized) are fully open when using the Load Bank. If exhausting through a screened opening, check screen periodically for any blockage. Screen needs to be a minimum 75% open area and at least as large as Load Bank core dimensions. The screen will add additional system resistance to airflow.
9. After running a load test, residual heat may be removed from the Load Bank and downstream duct work by allowing the blower to operate for a few minutes after load is removed. This procedure is not required for maintaining Load Bank integrity, but it may guard operating personnel from possible burn injuries.

## *Safety Considerations*

Avtron Model K711 Load Bank, Resistive, Duct Mount  
• Serial Number 3118 and Above

---

10. The operator should avoid coming in contact with the resistor elements or surrounding covers during and for some time after operation. These portions of the Load Bank become quite hot and may result in a serious burn should contact be made with them.
11. Operators must not operate the Load Bank with the access panels or screens removed. To do so would expose the operator and other persons to possible personal injury from electrical shock.
12. An approved electrical fire extinguisher should be on hand at all times.
13. It is the responsibility of the customer to take diligent care in installing the Load Bank. The National Electrical Code (NEC), sound local electrical and safety codes, and the Occupational Safety and Health Act (OSHA) should be followed when installing the equipment to reduce hazards to persons and property.
14. Prior to handling the unit, review the INSTALLATION section of this manual.
15. The Load Bank is designed for maximum 120°F ambient at 3,000 ft. maximum elevation. Consult factory if either of these conditions is not met.
16. Standard K711 units which do not include the outdoor (louver) option must have field installed provisions to protect personnel from coming into contact with load resistor elements.
17. Read and heed all **WARNING** and **CAUTION** statements in the manual.

## SECTION II

### DESCRIPTION AND SPECIFICATIONS

The Avtron Model K711 is designed to be used as a duct- or radiator-mounted Load Bank providing custom tailored mounting and installation. The K711 provides a resistive load rated as indicated on the Table of Contents. Minimum airflow required to cool the elements operating at full load is as indicated on the Table of Contents and must be maintained to ensure safe operation of the Load Bank.

\*\*\*\*\*

#### CAUTION

To prevent load element burnout, adequate airflow must be maintained over the entire load element area at all times voltage is applied. Insufficient air for even a few seconds will cause element burnout. This unit must have uniform airflow over the entire outlet area. If there are dead spots, damage to the elements may result.

\*\*\*\*\*

#### CONTROL PANEL

The K711 Load Bank may be provided with a Control Panel as an option or the Control Panel may be customer supplied. The Control Panel may be supplied by Avtron in one of the following ways:

1. Factory installed on the side of the Load Bank without an enclosure.
2. Factory installed on the side of the Load Bank within an enclosure.
3. Factory installed within a remote mountable enclosure, separate from the Load Bank.
4. Factory supplied without an enclosure for remote mounting.

The Control Panel, when provided, serves as the manual control center for Load Bank operation. All load switches, safety indicator lights, and control circuit fuses are mounted on the panel.

When the Control Panel is not factory supplied, load application and safety circuitry are the responsibility of the customer.

Each Load Bank is designed with a relay compartment which contains load contactors, safety circuit components, optional load step fusing, optional control transformer with fuses, and a customer connection bus. If a Control Panel is not factory installed, the components in the relay compartment will require interconnection wiring during field installation of the Load Bank.

Interconnection wiring should conform to the National Electrical Code and any local codes.

### **DUCT/FLANGE ADAPTERS (K711 ONLY)**

Removable duct/flange adapters are provided to assist in the installation of the Load Bank to a ventilation duct or the exhaust end of a radiator.

1. If required, remove the adapter frame from the Load Bank by removing the hardware that attaches the adapter frame to the two vertical walls of the Load Bank radiator core opening. Remove the corner hardware which attaches vertical adapters to horizontal pieces. Also remove the hardware (if provided), attaching the horizontal adapter pieces to the top and bottom flanges.
2. Locate and drill holes on the vertical adapter as required to match the duct/flange mounting holes. (See CAUTION below.) The top and bottom horizontal sections of the adapters are duct/flange extensions only.

\*\*\*\*\*

### **CAUTION**

The two vertical sections for the duct/flange adapters are the primary load carrying members. Fixture adapters so that load is transmitted through these vertical sections. Add field installed supports between Load Bank and a static point as required on units whenever load carrying capacity of vertical adapters is in question.

\*\*\*\*\*

3. Reattach the adapter frame to the Load Bank.
4. Mount the Load Bank to the duct or radiator.

### **AUTO TRANSFER SWITCH CAPABILITY**

The load control circuitry is factory designed in such a way that remote operation with a customer-supplied transfer switch may be incorporated into the circuit. The factory control circuitry will be wired to a terminal board whereas a transfer switch must be enabled and connects at the terminal board per the schematic.

### **AUTOMATIC OPERATION**

An Automatic Load Shed Controller (Controller) may be integrated into the control circuitry of the K711 Load Bank as an option. The Controller is designed to maintain a minimum load on a power source. A separately supplied current transformer provides the feedback signal required to operate the Controller. This feedback signal drives the Controller, which has field adjustable current setpoints. The Controller also incorporates field adjustable time delays to prevent repetitive load switching or initial overloading of the generator.

The Load Bank manual controls are paralleled by the automatic Controller. Automatic or manual mode may be chosen when the Load Shed option is provided with the Load Bank.

### **LOUVERS (OPTIONAL)**

The exhaust of the Load Bank may be protected by either a stationary or motorized louver assembly. Due to exhaust temperatures, a stationary louver is the preferred option.

The motorized version would be added by end users and must include a limit switch which prevents the application of load steps if the louvers are not fully open. Verify louver and operating device are able to withstand exhaust temperatures before installation.

## SECTION III

# INSTALLATION

### NOTE

The outline drawing needs to be available while reviewing the INSTALLATION section.

The following steps outline general guidelines for the handling and installation of the Model K711 Load Bank. The first portion of Section III describes the handling (rigging) and physical mounting of the Load Bank. It is followed by a brief explanation on installing the unit.

It is the responsibility of the installing contractor to ensure all local laws, rules and regulations are followed for the installation procedure. All laws, rules, and regulations take precedence over this procedure.

\*\*\*\*\*

### WARNING

To prevent injury or death to personnel, never place any portion of body under the Load Bank while handling or rigging. These procedures are guidelines only and do not fully detail the scope of work required for complete installation. The rigger (installing contractor) and his equipment must meet all safety and code regulations.

\*\*\*\*\*

### PREREQUISITES TO HANDLING

1. The Load Bank must be on a level surface at ground elevation. Inspect for damage at time of arrival. Any damage must be reported to freight carrier prior to acceptance at customer's site.
2. Remove shipping crate sides but leave unit on skid.

3. Verify that all access panels (bolt on panels) are fully secured.
4. There are two methods to handle the Load Bank: Overhead lift using a spreader bar for hoisting the Load Bank into position or base lifting with a forklift. Installation/rigging contractor should obtain equipment for one or the other option:
  - a. **OVERHEAD LIFT VIA SPREADER BAR:** Use a spreader bar with two double leg type slings (minimum 3 ft. long). See recommendations on spreader bar below.
  - b. **BASE LIFT VIA FORKLIFT:** Use a forklift with forks (tines) at least 36" on center and adequate lift capacity.
5. End user to provide all mounting fasteners, any supplemental fabricated components, and supports for installation, if used. Field drilling and or modification to mounting locations are the responsibility of the installing contractor.

#### HANDLING THE LOAD BANK

##### A. Overhead Lift via Spreader Bar

#### NOTE

A crane with sufficient capacity and lifting height will be required to hoist the Load Bank from skid (shipping crate) and to raise the Load Bank for final positioning. Lifting cables, chain slings, and spreader bar are required and shall be supplied by the rigger. It is recommended to use a spread bar equal to or slightly longer than the Load Bank. All rigging equipment should be rated at five times the basic Load Bank weight.

1. Note the orientation of the spreader bar lifting points should be aligned with the four 1" diameter top flange lifting holes in the Load Bank (see outline drawing). Primary spreader bar needs to be in line with the Load Bank resistor element section. Spreader bar is to be parallel to longitudinal direction of the Load Bank frame.
2. Hook up spreader bar to crane and top four lifting points on Load Bank frame.
3. The spreader bar can be used with double leg slings or two cables or chains, each a minimum of three feet long. Slowly lift spreader bar and verify all slack is removed evenly from all four slings/cables/chains. If not, lower and readjust as required until uniform lift is obtained.

4. Test and verify that the unit is level by lifting the Load Bank. Raise unit up no more than 6 inches off the ground. Lower and adjust if required to obtain a level lift (level within 6 inches).
5. The rigger should now attach a guide wire to one corner of the Load Bank for stabilization.
6. Keep the Load Bank close to ground and position near final lift point.
7. After verification of all rigging, hoist Load Bank vertically and position near final mounting.
8. Install a support below the Load Bank frame as a safety support. Refer to the installation notes which follow.

**B. Base Lift via Forklift**

1. The non-symmetrical design of the Load Bank creates an off-center unbalanced condition. The Load Bank needs to be supported across the entire base for forklift handling. Use the shipping crate skid or erect a support base adequate for the lifting loads encountered.
2. Attach a secondary guide or support bar to boom of forklift.
3. Lift Load Bank less than 3 inches off ground and check for proper balance. Make any adjustments as required to adequately support the unit.
4. Position Load Bank near final mounting.
5. Install a support below the Load Bank frame as a safety support. Refer to the installation notes which follow.

\*\*\*\*\*

**WARNING**

When using a forklift, the Load Bank should only be lifted under base with a skid or secondary support base (supplied by others) to prevent frame damage.

\*\*\*\*\*

MOUNTING THE LOAD BANK

\*\*\*\*\*

**CAUTION**

The radiator frame or structural supports and mounting hardware used to permanently mount and anchor the Load Bank must be designed with sufficient safety factors to not yield under static and dynamic loading. These dynamic loads include but are not limited to wind loads, seismic qualification, and any supplemental weight added to equipment.

\*\*\*\*\*

This Load Bank is designed for direct installation in a ventilation duct or on the exhaust end of a radiator. A fabricated Duct/Flange Adapter is provided as noted in Section II. Since radiator designs vary by manufacturer and size, these flange adapters are not universal. In some cases a custom fabricated interface between the duct or radiator and the Load Bank is required. If required, custom fabrication to adapt the Load Bank mounting face to the duct/radiator mounting face is acceptable to aid installation. This custom fabricated section would be designed, fabricated, and installed by the installing contractor. Other than this mounting interface, conventional hand tools are required for installation.

If not using the duct flange adapter provided, the Load Bank should be mounted off the top and bottom flanges. After mounting, verify adequate clearance between any electrical component and mounting hardware.

Bulletin 202 shows the proper positioning of the Load Bank in the air duct.

\*\*\*\*\*

**CAUTION**

To prevent load element burnout, adequate airflow must be maintained over the entire load element area at all times voltage is applied. Insufficient air for even a few seconds will cause element burnout. This unit must have uniform airflow over the entire outlet area. If there are dead spots, damage to the elements may result. Minimum uniform airflow velocity is 850 feet per minute. Recommended velocity is 1,000 feet per minute across entire load element area.

\*\*\*\*\*

In general, the protection provided external to the Load Bank is determined by the local codes. Since the Load Bank is generally part of an existing electrical installation, it must be protected by a fused disconnect or circuit breaker meeting all local codes.

Before making any electrical connections, the maximum phase current for the Load Bank should be determined. This may be done using the following formula.

$$I_{\text{PHASE(MAX)}} = \frac{\text{kW} \times 577}{V \text{ (Line-to-Line)}}$$

\*\*\*\*\*

**CAUTION**

When installing the Load Bank, do not drill into side flanges. Use factory provided flange adapters or if not using adapters, use only top and bottom flanges as mounting locations. Compliance with this instruction helps guard against damage to internal wiring.

\*\*\*\*\*

The electrical connections necessary for proper operation of the Load Bank are as follows:

1. Connect the load power source as indicated on the Schematic/ Interconnection Diagram.
2. A ground connection must be made to the Load Bank (GND terminal) to prevent injury to personnel. This may be accomplished by a ground wire connected directly to the Load Bank ground stud provided in the control box. This ground wire should be connected to the frame of the generator under test. The generator frame should be grounded to a good earth ground.
3. Make control circuit connections as required using #14 AWG wire minimum. Refer to the Schematic Diagram found at the end of this manual for the required control voltage. For conduit runs greater than 50 feet, consult the factory.
4. When an automatic Controller is included with the Load Bank, installation of the current transformer on the main power bus as shown in Figure 3-1 is required. Wire the current transformer into the control circuitry as shown on the provided schematic.

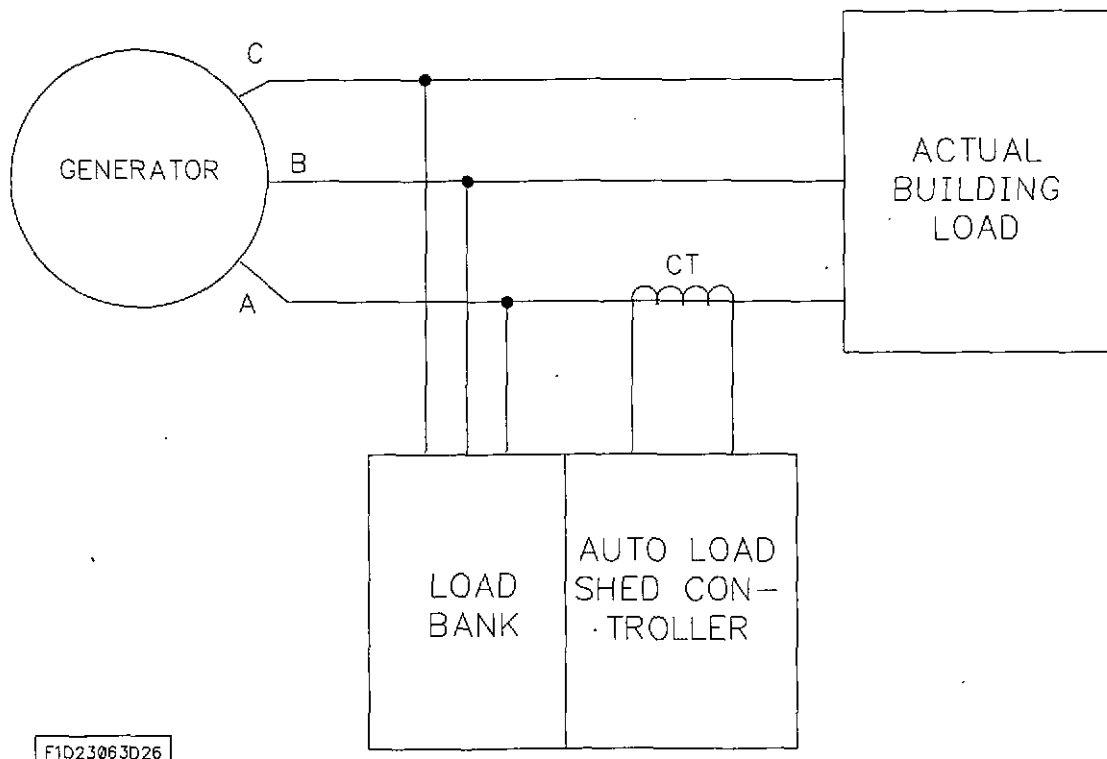

Figure 3-1

\*\*\*\*\*

**WARNING**

Always put a short or shunt across the current transformer when servicing the Load Bank. Primary current flowing through an unshunted current transformer will destroy the transformer with possible harm to personnel.

\*\*\*\*\*

Never allow the secondary of the current transformer to remain disconnected when primary current is passing through the transformer. If the Load Bank must be disconnected, put a short or shunt across the current transformer.

**NOTE**

Before placing the system into AUTO, place the Load Bank load step switch(es) to the OFF position.

**OPTIONAL CONTROLLER OPERATION AND ADJUSTMENTS**

\*\*\*\*\*

**WARNING**

Always put a short or shunt across the current transformer when servicing the Automatic Load Shed Controller. Primary current flowing through an unshunted current transformer will destroy the transformer with possible harm to personnel.

\*\*\*\*\*

**THEORY OF OPERATION**

The automatic operation circuitry of the Load Bank allows for a generator to which it is connected to maintain a minimum percentage of its rated output for efficient generator operation. The control range is generally between 60% and 80% of the output rating of the generator.

**SYSTEM SETPOINT CALCULATION (Example)**

**System Ratings**

Generator Resistive Rating = 375 kW @ 480 VAC, 3 PH.  
 Load Bank Shedder Capacity: 225 kW @ 480 VAC, 3 PH.  
 Load Steps: 25, 50, 50, 50, and 50 kW.  
 Actual Generator Output = Load Bank Load + Building Load.

<u>Trip Point</u>	<u>BUILDING LOAD</u>	<u>LOAD BANK LOAD</u>	<u>ACTUAL GENERATOR OUTPUT</u>	<u>% OF GENERATOR</u>
TP.1	0-<75 kW	225 kW	225-300 kW	(60%-80%)
TP.2	>=75-<125 kW	175 kW	225-300 kW	(60%-80%)
TP.3	>=125-<175 kW	125 kW	225-300 kW	(60%-80%)
TP.4	>=175-<225 kW	75 kW	225-300 kW	(60%-80%)
TP.5	>=225-<275 kW	25 kW	225-300 kW	(60%-80%)
TP.6	>=275 kW	0 kW	BUILDING LOAD	(>=73%)

At 0 kW building load, the Load Bank will provide 225 kW worth of load. Actual generator output will be 225 kW (60%) after a preset time-delayed ramp up period.

As the building load increases and the actual generator output approaches 300 kW (80%), the controller disables one load step; in this example, the last 50 kW load step “sheds”.

This load shed control continues as the building load continues to increase. If the building load decreases, causing the actual generator load to fall below 60%, the controller will add the appropriate load step(s) to maintain the desired range of control.

## TRIP POINT ADJUSTMENTS

In the system example detailed above, a current transformer having a ratio of 500:5 will be used to monitor the building load. (Refer to Figure 3-1.) As the actual generator output reached 300 kW, the controller "shed" a load step. The current flowing to the building load at this point will be called the current trip point. This "trip point" value can be determined using the following formula:

$$\text{LINE CURRENT}(I(\text{line})) = (\text{kW} * 577) / \text{VOLTAGE}(\text{LINE-to-LINE}).$$

$$\begin{aligned} \text{In this example } I(\text{line}) &= (75 * 577) / 480, \\ &= 90.1 \text{ amps} \end{aligned}$$

**NOTE: FOR SINGLE PHASE SYSTEMS:**

$$I(\text{LINE}) = \text{WATTS} / \text{VOLTAGE}(\text{LINE-to-LINE}).$$

### Secondary Current Calculation

The controller senses the current ( $I_{\text{sense}}$ ) delivered from the current transformer that is monitoring the building load. This value can be determined using the following formula:

$$I(\text{sense}) = I(\text{line}) / \text{CT Ratio}.$$

In this example, the CT Ratio = 500/5 or 100.

For TP.1  $I(\text{sense}) = 90.1 / 100$  or .90 amps ( 75 kW)

For TP.2  $I(\text{sense}) = 150 / 100$  or 1.5 amps (125 kW)

For TP.3  $I(\text{sense}) = 210 / 100$  or 2.1 amps (175 kW)

For TP.4  $I(\text{sense}) = 270 / 100$  or 2.7 amps (225 kW)

For TP.5  $I(\text{sense}) = 331 / 100$  or 3.3 amps (275 kW)

Adjustments can be made to the PC board controller via the adjustable resistor potentiometers found on the PC board. (Reference resistors labeled LEVEL PERCENT, R73, R60, R47, R34, and R21.)

### NOTE

R73 controls the last load step circuit. (i.e., if the Load Bank has five load steps, R73 controls the fifth load step.)

The potentiometers should be adjusted such that the last load step is the first step to be "shed". On the Controller, there is an LED indicator for each channel (Output). When lit, the channel is energized.

In this example, R73 = TP.1	Channel 5 (LED CR29)
R60 = TP.2	Channel 4 (LED CR25)
R47 = TP.3	Channel 3 (LED CR21)
R34 = TP.4	Channel 2 (LED CR17)
R21 = TP.5	Channel 1 (LED CR13)

The "trip point" value = I(sense) can be applied to the controller terminals J1 and J2 using a separate current source.

There are two methods of field adjusting the trip point of the current sensing relays:

- Method 1 - Using a separate (0-5 amp) current source without the current transformer
- Method 2 - Rough adjustment (Approximation Method)

**Method 1** - Using a separate (0-5 amp) Current Source without Current Transformer

1. Disconnect all sources of power to the Automatic Load Shed Controller (control voltage and current sense input).

\*\*\*\*\*

**WARNING**

When disconnecting the current transformer, the secondary terminals must be shorted. The secondary of an unshorted current transformer can exceed several thousand volts.

\*\*\*\*\*

2. Apply 120 VAC, 60 Hz control power J1(10-12) (see schematic).

\*\*\*\*\*

**WARNING**

There is lethal high voltage within the control enclosure.

\*\*\*\*\*

3. Using a controlled current source, apply the setpoint current (from secondary current calculation) to Controller terminals J1(1) and J1(2).
4. Turn the adjustment potentiometer labeled LEVEL PERCENT counterclockwise past the trip point; then decrease until the channel trips on, indicated by LED illuminating.
5. Reconnect all wires previously removed.

Method 2 - Rough Adjustment

NOTE

Adjustable potentiometers on the controller board have a % scale reference that directly relates to the current, ( $I_{sense}$ ), delivered from the current transformer used to monitor the building load. Refer to **Secondary Current Calculation** under **Trip Point Adjustments** earlier in Section III of this manual. The scale is based upon a 5 amp input.

.5 amp	=	10% Dial Setting
1.25 amp	=	25% Dial Setting
2.5 amp	=	50% Dial Setting
3.75 amp	=	75% Dial Setting
5.0 amp	=	100% Dial Setting

With all power removed from the Load Bank, calculate each desired Trip Point and adjust the LEVEL PERCENT potentiometers (R21, R34, R47, R60, R73) in order to achieve a rough adjustment controller setting.

NOTE

The current sense relay settings must be set sequentially. It is extremely important that the sequence be correct because the current sense relays are interlocked by the previous relay. Consult the factory at 216-573-7600 if unsure of proper adjustment.

**INSTALLATION CHECKOUT PROCEDURE -  
TO BE DONE PRIOR TO OPERATION**

This Installation Checkout procedure is intended to be used upon initial receipt of equipment and following any relocation of a permanently-mounted Load Bank. These procedures apply to Load Banks in general and may include steps not relevant to the specific unit being installed. Disregard those procedures which do not apply.

\*\*\*\*\*

**WARNING**

THE FOLLOWING TESTS ARE TO BE ACCOMPLISHED BY A QUALIFIED ELECTRICIAN OR TECHNICIAN USING EXTREME CAUTION AS POTENTIALLY LETHAL VOLTAGES AND DANGEROUS ROTATING COMPONENTS ARE PRESENT. IF ASSISTANCE IS REQUIRED, AVTRON CAN PROVIDE START UP SERVICE AT A NOMINAL CHARGE. AVTRON ALSO WILL PROVIDE TELEPHONE ASSISTANCE IF REQUIRED BY CALLING (216) 573-7600.

\*\*\*\*\*

1. Verify the Load Bank placement meets the installation requirements found in the Installation section of this instruction manual:
  - A. Check the clearance from both intake and exhaust to any obstruction.
  - B. If the location has a prevailing wind, make the wind aid in the cooling of the resistor elements.
  - C. If the Load Bank is elevated, a plate under the Load Bank will be needed to block hot exhaust from returning to the intake.
  
2. Check the mechanical integrity of all customer-supplied interconnection wiring:
  - A. Check lugs that they are properly crimped.
  - B. Check terminations that they are properly torqued.

3. Utilize system schematics to ohm out customer-supplied interconnection control wiring and safety circuits:
  - A. If control wiring is all the same color, ohm out each individual wire to confirm proper labeling and placement.

**CAUTION**

Control wiring must be a minimum of 14 AWG for wire runs under 50 feet. Consult Avtron factory for wire sizing when wire run exceeds 50 feet.

- B. Confirm the correct wire gauge has been used for interconnection wiring. Control wiring should be a minimum of 14 AWG for control panel to Load Bank lengths of 50 feet or less. For lengths greater than 50 feet, consult the factory.
- C. If a Control Transformer is the source of control power, disconnect the control transformer before proceeding.

**CAUTION**

When control power is supplied by a transformer within the Load Bank, it must be disconnected before running this installation checkout procedure. Failure to disconnect the control transformer may damage the Load Bank.

4. Energize the source of control power only. Check the control voltage and confirm it is within 10% of the required voltage.

\*\*\*\*\*

**WARNING**

Control power is present on terminal block in steps 4 through 6.

\*\*\*\*\*

5. Verify the proper relays energize with each individual load switch.
  - A. Turn on each load step individually and observe that each relay or relays pulls in without chatter or hesitation.
  - B. Turn off the master load switch. Turn on all the load steps. Turn the master load on and observe the pull in of all the contactors. If chatter or hesitation is observed, locate the cause of the voltage drop causing the problem.
6. Apply the rated fan voltage. Start blower and verify that air is exiting the resistor assembly end.

This checkout procedure is intended to be a guide to Load Bank installations in general. Special installation considerations not addressed herein may be necessary due to installation site or environment. Any questions or concerns regarding Load Bank installation should be directed to Avtron Field Service at (216) 573-7600.

## SECTION IV

### OPERATION

\*\*\*\*\*

#### CAUTION

DO NOT operate the Load Bank over the rated voltage as this will cause a catastrophic failure in the Load Bank.

DO NOT apply DC voltages to the Load Bank because the contactors do not have arc blowout magnets.

To prevent load element burnout, adequate airflow must be maintained over entire load element area at all times voltage is applied. Insufficient air for even a few seconds will cause element burnout.

It is important to note that if the generator is removed, the control circuit may still be energized if control power is not removed. Therefore, before removing cover, make certain all sources of power to the Load Bank are disconnected.

\*\*\*\*\*

The K711 Load Bank may be operated in a manual mode or, if the Load Shedder option is provided, in an automatic mode. Operation instructions for the different modes are as follows:

1. Manual Operation - K711 units without a Control Panel.
2. Manual Operation - K711 units with a Control Panel included as an option.
3. Automatic Operation - K711 units with the Load Shedder option.

Take note that in cases where the K711 Load Bank is provided with the transfer switch option to permit load application, the terminal board terminals referenced on the schematic for this application must be connected either by a hard wired jumper or a closed transfer switch contact.

**MANUAL OPERATION (for K711 units without a Control Panel)**

After mounting the K711, connecting 120V control power, and running interconnecting control wires per the schematic:

1. Check to confirm that all load contactors will not be energized prematurely.
2. Connect generator or other source to be tested to the Load Bank as described in the INSTALLATION section.
3. Apply power to the control circuit. (If Load Bank has motorized louvers, verify louvers are open prior to the initiation of airflow.)
4. Start power source under test. Be sure air is flowing over resistance elements.
5. Apply load to the power source by energizing load contactors.
6. Shutdown - After running a load test, residual heat may be removed from the Load Bank and downstream duct work by allowing the blower to operate for a few minutes after loads are removed. This procedure is not required for Load Bank integrity, but it may guard operating personnel from possible burn injuries.

**MANUAL OPERATION (for K711 units with a Control Panel included as an option)**

After mounting the K711, connecting 120V control power, and running interconnecting control wires per the schematic:

1. Place all switches on the Control Panel to the OFF position.
2. Place AUTO/MANUAL switch to MANUAL. (This step only applies to Load Banks with Load Shedder option.)
3. Connect the generator or other power source to be tested to the Load Bank as described in the INSTALLATION section.
4. Place the POWER switch to the ON position. The POWER light will be energized indicating control power is present. (If Load Bank has motorized louvers, verify louvers are open prior to the initiation of airflow.)
5. With the MASTER LOAD switch in the OFF position, start the generator under test. Using a customer-supplied blower, be sure air is flowing over the resistance elements.

6. The resistive loading is selected by load step switches, using any one or a combination to make up a given load.
7. Apply load to the power source by moving the MASTER LOAD switch to the ON position.
8. Any load can be added or removed during MANUAL testing provided the MASTER LOAD switch is on.
9. To remove all loads, move MASTER LOAD switch to the OFF position.
10. Shutdown - Place all switches in the OFF position. After running a load test, residual heat may be removed from the Load Bank and downstream duct work by allowing the blower to operate for a few minutes after loads are removed. This procedure is not required for Load Bank integrity, but it may guard operating personnel from possible burn injuries.

**AUTOMATIC OPERATION (for K711 Load Banks with Load Shedder option)**

After mounting the K711 and connecting 120V control power per the schematic:

1. Place all switches on the Control Panel to the OFF position.
2. Connect the generator or other power source to be tested to the Load Bank as described in the INSTALLATION section.
3. Place the POWER switch to the ON position. The POWER light (DS1) will be energized, indicating control power is present. (If Load Bank has motorized louvers, verify louvers are open prior to the initiation of airflow.)
4. Place AUTO/MANUAL switch to AUTO.
5. Start the generator under test. Using a customer-supplied blower, be sure air is flowing over the resistance elements.
6. When the Auto Transfer Contact is open, the Auto Load Shedder will be active. As the load on the generator lessens, the Load Shed Controller will automatically apply load steps until the overall generator load exceeds the minimum setpoint. The Load Shed Controller automatically removes load steps when the generator load exceeds the maximum setpoint.

## SECTION V

### REPLACEMENT PARTS LIST

SCHEMATIC REFERENCE	DESCRIPTION	AVTRON P/N	QTY/ UNIT
F101	FUSE, 10A, 600V	324128	1
XF101	FUSEHOLDER	325022	1
DS21	LIGHT, INDICATOR, (RED)	329048	1
DS20, DS50	LIGHT, INDICATOR, (GREEN)	329049	*
S60	SWITCH, TEMPERATURE	360379	1
S1-S9, S20, S21, S50	SWITCH, TOGGLE	360589	*
CT2, 3	<u>OPTION R:</u> CURRENT TRANSFORMER FOR DIGITAL METERING	370537	2
CT2, 3	<u>OPTION S:</u> CURRENT TRANSFORMER FOR DIGITAL METERING	370936	2
CT2, 3	<u>OPTION T:</u> CURRENT TRANSFORMER FOR DIGITAL METERING	370937	2
CT2, 3	<u>OPTION U:</u> CURRENT TRANSFORMER FOR DIGITAL METERING	370932	2
CT2, 3	<u>OPTION V:</u> CURRENT TRANSFORMER FOR DIGITAL METERING	370908	2
CT2, 3	<u>OPTION W:</u> CURRENT TRANSFORMER FOR DIGITAL METERING	370934	2
CT2, 3	<u>OPTION X:</u> CURRENT TRANSFORMER FOR DIGITAL METERING	370935	2
* Quantity is dependent on option(s) purchased.			

# DRAWINGS

## PROPRIETARY NOTE

The wiring diagrams and schematics which follow contain information PROPRIETARY to Avtron, Inc. They are furnished solely to provide information sufficient for instruction, operation, maintenance, evaluation, and testing of the equipment herein disclosed; are not to be used for manufacturing or procurement; and are not to be disclosed to anyone other than persons in the Division, or the Company, or the Government, as the case may be, responsible for action relating to this document without the express written permission of Avtron, Inc.





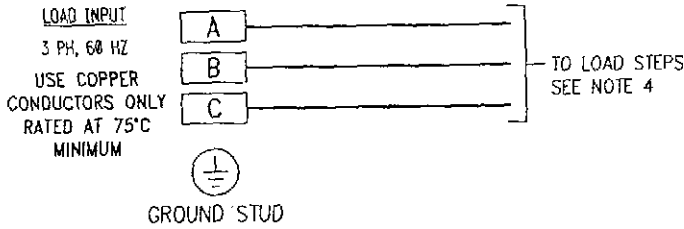
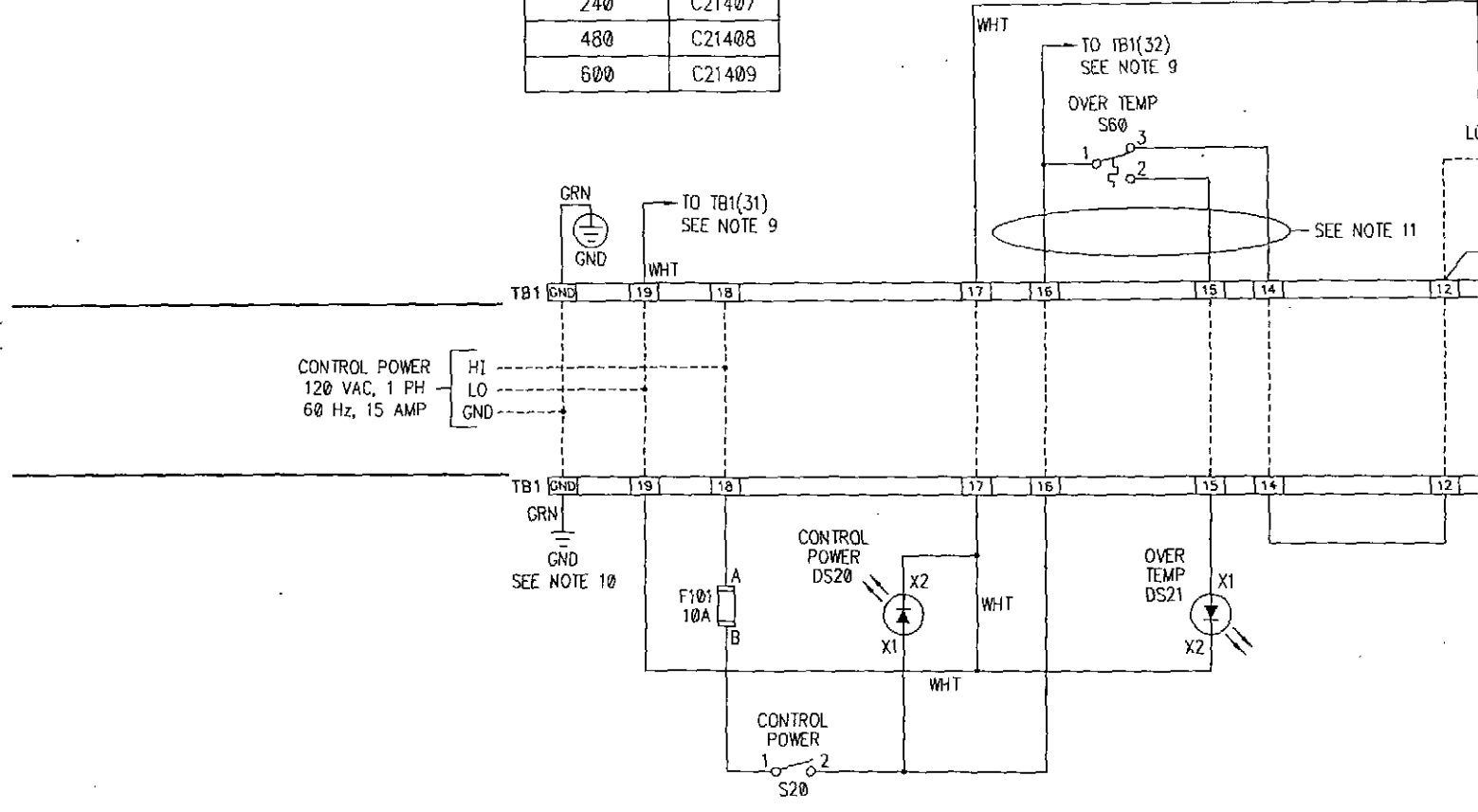

TABLE. POWER SCHEMATIC

VOLTAGE	P/N
208	C21406
240	C21407
480	C21408
600	C21409



CONTROL

1. WIRE CODE:  
ALL WIRE TO BE BLACK UNLESS OTHERWISE SPECIFIED.  
ALL UNMARKED WIRE TO BE #16 AWG (PN 390008)
2. --- DASH LINES REPRESENT CUSTOMER WIRING.  
— SOLID LINES REPRESENT AVTRON WIRING.
3. FOR REMOTE LOAD DUMP IN THE MANUAL MODE REMOVE JUMPER AND INSTALL N/C CONTACT.
4. RESISTIVE ELEMENTS, RELAY CONTACTS, AND LOAD STEP FUSING SHOWN ON THE POWER SCHEMATIC. (SEE TABLE) FOR K711B REF ITEMS (35-38) OF K711B DRAWING.
5. IF MORE THAN QTY(1) RELAY PER LOAD CIRCUIT USE A,B,... TO DIFFERENTIATE THE RELAYS WITHIN THE LOAD CIRCUIT.
6. THE NUMBER OF CIRCUITS AND SWITCHES IS DEPENDENT ON THE NUMBER OF LOAD STEPS.

7. ON LOAD BANKS WITH A REMOTE CONTROL PANEL, (SEE TOP ASSY), THERE WILL BE A "TB1" ON THE REMOTE CONTROL PANEL AND ON THE LOAD BANK, CUSTOMER IS TO WIRE "TB1" ON THE LOAD BANK TO "TB1" ON THE REMOTE CONTROL PANEL.
8. ON LOAD BANKS WITH A REMOTE CONTROL PANEL, (SEE TOP ASSY), SEE NOTE 7. IF THE CONTROL PANEL IS LOCAL THE 2 TB1'S ARE THE SAME PART.
9. WIRE ONLY IF METERING IS SPECIFIED, (SEE TOP ASSY).
10. RUN GROUND WIRE TO BOLT OF F101 MOUNTING.
11. FOR K711B ONLY- WIRES TO BE INSTALLED BY CUSTOMER, MIN #14 AWG, OTHERWISE AVTRON TO WIRE.

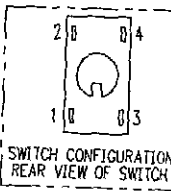

UNLESS OTHERWISE SPECIFIED THE ABOVE NOTES APPLY

D BANK

REVISIONS				
ECN NO.	REV	DESCRIPTION	DATE	APPROVED
COB50	A	TB1(GND) WAS TB1(20). "TO TB1(32)" WAS "TO TB1(33)". "TO TB1(31)" WAS "TO TB1(32)".	J.FLAUTO 11/9/04	KUK
CE345	B	REV PER ECN	FACKELMANN 3/7/05	D.STACK
CE730	C	REVISED NOTE 4, ADDED NOTE 11	FACKELMANN 1/30/07	D.STACK

SEE NOTES 5 & 6

REMOTE  
LOAD DUMP

NOTE 3

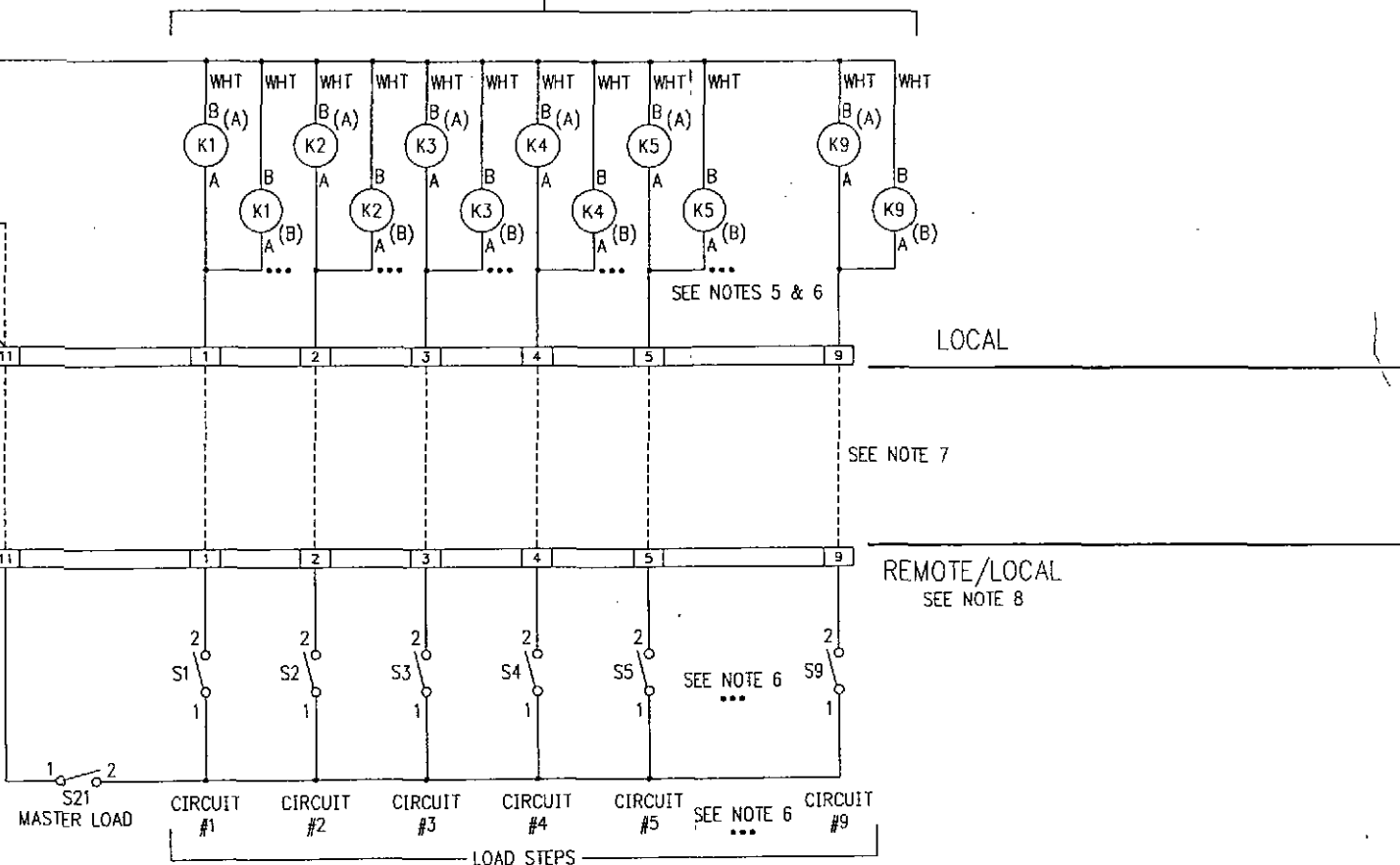

PANEL

THIS DOCUMENT CONTAINS PROPRIETARY INFORMATION OF AVTRON MFG., INC. AND MAY NOT BE DISCLOSED TO OTHERS OR USED FOR MANUFACTURING PURPOSES WITHOUT THE WRITTEN CONSENT OF AVTRON MFG.

		UNLESS OTHERWISE SPECIFIED DIMENSIONS ARE IN INCHES	DRAWN FACKELMANN	DATE 5/19/04	7900 E. PLEASANT VALLEY ROAD INDEPENDENCE, OH 44131-5529	IMF <input checked="" type="checkbox"/> PSF <input type="checkbox"/>
		TOLERANCES: DECIMALS .XX± .03 .XXX± .015	CHECKED J.FLAUTO	DATE 6/3/04		
		FINISH	ENG APVD K.KUK	DATE 6/2/04	SCHEMATIC/INTCON DIAGRAM	
		PAINT PER PS	APVD PROD A.VYSSOTSKY	DATE 6/16/04		
NEXT ASSY	USED ON	PLATE PER			SIZE D	CAGE NO. 01014
APPLICATION		COAT PER PS			DWG. NO. D36481	REV C
		ANODIZED PER			SCALE 1/1	MODEL K711
		OTHER			SHEET 1 OF 1	



Since the load banks absorb 100% of their rating as soon as voltage is applied regardless of air flow, it is necessary to install them properly to prevent damage or malfunctions. Outlined below are some practices which should be followed.

- AIR FLOW** - The air flow through all sections of the load bank should be at least 800 ft/min. and preferably 1000 ft/min. or greater. The air flow should not be blocked from some sections of the load bank or the load bank installed so there are areas of "dead" air. See Bulletin 203 for method of air flow computation. Elevation view is shown below. Similar layout in plan view except allow approximately 18" beyond duct or core dimensions for control area. See outline drawing.

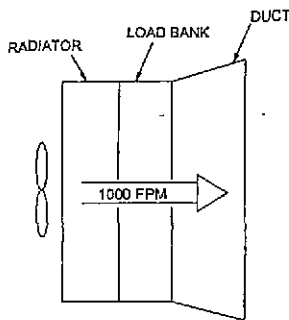

RIGHT

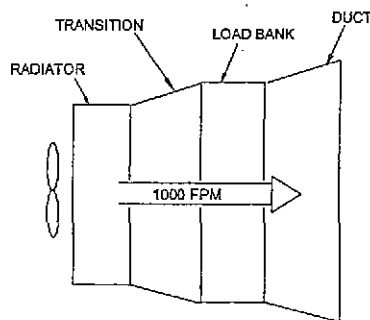

RIGHT

(PREFERRED IF OVERSIZED  
 LOAD BANK IS REQUIRED)

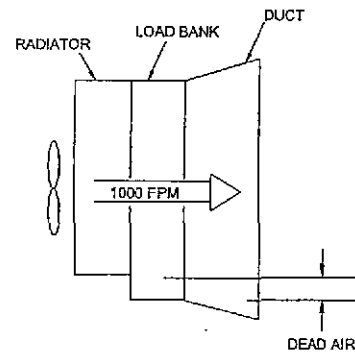

WRONG

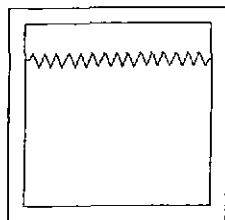

RIGHT

LOAD  
 ELEMENT

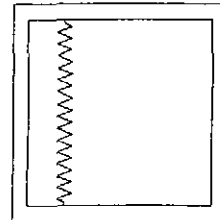

WRONG

★ Rev. 7/25/00

BULLETIN 202  
INSTALLATION NOTES  
ENGINE GENERATOR DUCT  
TYPE LOAD BANKS  
Page 2 of 2

2. ELEMENT POSITION - The elements are designed for horizontal installation to prevent sagging or movement that would cause damage. The load bank should be installed with the elements horizontal, as shown above.
3. RATED CURRENT AND FUSING - When installing the load bank, it is necessary to provide the proper size wire and, if fuses are required, they must be selected so they are compatible with the load steps and voltage applied to the unit. The current drawn by the load bank may be computed from the formula:

$$I = \frac{KW \times 577}{\text{Voltage (Line-to-Line)}}$$

For example, a 100 KW load bank will draw 120 amperes at 480 volts and 240 amperes at 240 volts. For the low voltage installation, the fuse rating and wire size must have twice the current capacity of the high voltage installation. Load banks can be installed with a load connected as a single step or multiple small steps, and the fuses and wire size should be selected accordingly.

4. PARTIAL DUCT INSTALLATIONS - There may be installations where only a small amount of load is required relative to the generator rating and duct size. Avtron recommends that a load bank be selected which is large enough to match the size of the engine air duct. If this is not feasible, a smaller load bank can be used which will only fill a part of the duct. Under these circumstances, it is the installer's responsibility to insure that sufficient air passes through the load bank for proper cooling.
5. INSTALLATION NOTES FOR UNITS OVER 50" WIDE - Units over 50" wide have a full perimeter frame which matches design size (duct or radiator core width). A secondary fixed internal load element support panel is used in these widths. As long as uniform air flow of at least 800 ft./min. is provided across load elements, no problems should occur. However, cooling loss may occur due to air flow around load elements and through open area. In these rare cases, it may be necessary to add a baffle or similar device to direct air flow. Consult Avtron for design support in these cases.

## I. AIRFLOW CALCULATIONS

Load Banks are designed to operate with air passing over the load elements at a rate of approximately 1,000 ft./min. (5.08 meters/sec.). They will withstand higher air velocity without any problems as far as the Load Bank is concerned; however, the pressure drop across the Load Bank will increase. Therefore, this must be considered when selecting a Load Bank. When the air velocity is a great deal less than 1,000 ft./min., the load elements will operate at a higher temperature, which results in shorter life. At very low air velocity, the elements will overheat and be destroyed. The minimum uniform air velocity is 800 ft./min. across load element area.

Outlined below are simple methods of computing air velocity, pressure drop, and temperature rise for the Avtron K711 series duct type Load Banks.

### A. AIR VELOCITY COMPUTATIONS

When selecting a duct type Load Bank, the engine radiator parameters such as size and airflow are known. The Load Bank frame with dimensions closest to the effective dimensions of the radiator should be considered. For a given engine configuration, the airflow in cubic feet per minute or liters per second is supplied by the engine manufacturer. The velocity is calculated by using the effective area of the Load Bank and the engine airflow.

$$\text{Velocity (Ft. per Min.)} = \frac{\text{Engine Airflow (cu. ft./min.)} \times 144}{\text{Load Bank Width (in)} \text{ Load Bank Height (in)}}$$

$$\text{Velocity (meters/sec.)} = \frac{\text{Engine Airflow (Liters/Sec.)} \times 10}{\text{Load Bank Width (cm)} \text{ Load Bank Height (cm)}}$$

### B. PRESSURE DROP

The Avtron K711 series of Load Banks are designed to be compatible with typical radiator sizes and airflows. One important criterion in application of the Load Banks is the air pressure drop through the Load Bank. The engine generator sets are usually designed with sufficient fan capacity to provide a head of .5 in. H<sub>2</sub>O (12.7mm H<sub>2</sub>O) after the air has passed through the radiator. The Load Banks are designed to minimize the cooling air pressure drop. Typically, the louver type Load Banks have a pressure drop of about .2 in. H<sub>2</sub>O (5.08mm H<sub>2</sub>O) and the duct types have a drop of about .1 in. H<sub>2</sub>O (2.54mm H<sub>2</sub>O) at minimum rated airflow.



Style K711A units have slightly higher pressure drops. Consult Avtron for calculated system resistance. Verify air handling system can tolerate additional pressure drop and maintain at least 800 ft./min. across load elements.

### C. AIR TEMPERATURE RISE

In some installations, the allowable exhaust air temperature from the overall engine generator and Load Bank combination must be limited to a specific value. The temperature rise information on the engine generator combination can be supplied by the manufacturer. The air temperature rise through the Load Bank can be calculated from the following formula:

$$\text{Temp Rise (° F)} = \frac{\text{Load Bank KW} \times 3200}{\text{CFM}}$$

$$\text{Temp Rise (° C)} = \frac{\text{Load Bank KW} \times 570}{\text{Liters/Sec.}}$$

Depending on the installation, the cooling system exhaust air temperature rise may be compiled using the Load Bank temperature rise derived from the above calculation and adding it to the other system temperature rises.

#### NOTE

This is average air temperature rise. Parcels of air will significantly exceed this number. Areas with lower velocity will operate at higher temperatures.

## II. ELECTRICAL CALCULATIONS

### A. RATING

The Load Bank power ratings are based on the highest rated operating voltage. Each load step consists of two elements, each rated at 138 volts connected in wye. When connected in the series configuration, the Load Bank may be used on 480V or 380V, 3 Phase. With 480 volts applied to the terminals, 138 volts is applied to each element. When connected in parallel configuration, the Load Bank may be used on 240V or 208V, 3 Phase systems. With 240V, 3 Phase applied to the terminals, 138 volts is applied to each element. The load absorbed by the Load Bank at other than rated voltage can be computed from the formula:

$$\text{Absorbed KW} = \frac{\text{Rated KW} \times (\text{Applied Voltage})^2}{(\text{RATED VOLTAGE})^2}$$

For example, a 100 KW Load Bank connected for 240 volts with 208 volts applied will absorb 75 KW.

$$\text{Absorbed KW} = \frac{100 \times (208)^2}{(240)^2}$$

#### B. CURRENT CALCULATIONS

To determine the wire size and fuse ratings for a given installation, it is necessary to determine the line current. This can be readily determined from the formula:

$$\text{Phase Current} = \frac{\text{Absorbed KW} \times 577}{\text{Applied Voltage (Line-to-Line)}}$$

For example, a 100 KW load with 480 volts applied will draw 120 amperes per phase.

$$\text{Phase Current} = \frac{100 \times 577}{480}$$

#### C. REACTIVE LOAD CALCULATIONS

When engine generator sets are operated with Resistive (KW) load, they are being tested at unity (1.0) Power Factor. Some load tests require operation at lower power factors, usually .8 PF. To perform these tests requires a load with both Resistive (KW) and Reactive (KVAR) capability. The Resistive and Reactive parts of the total load add vectorially, not directly. For example, to load a 100 KW generator at .8 Power Factor requires a Resistive load with a capacity of 100 KW and a Reactive load of 75 KVAR. The total load (Resistive and Reactive) on the generator is expressed as Volt-Amperes (KVA) and is the product of current times voltage. Using the above example of 100 KW Resistive load and 75 KVAR Reactive load, the total load (KVA) on the generator is 125 KVA.



When the generator set rating is expressed in terms of Resistive load at a certain power factor (100 KW at .8 PF), the total load (KVA) and Reactive load (KVAR) can be calculated as outlined below.

$$\text{Total Load (KVA)} = \frac{\text{Resistive Load (KW)}}{\text{Power Factor}}$$

$$\text{KVA} = \frac{100}{.8} = 125$$

$$\text{Reactive Load} = \sqrt{(\text{KVA})^2 - (\text{KW})^2}$$

$$\sqrt{(125)^2 - (100)^2}$$

$$\sqrt{15625 - 10000}$$

$$\sqrt{5625} = 75 \text{ KVAR}$$

# Warranty

## Warranty and Duration

For a period of one year after installation, or fifteen (15) months from date of shipment from our plant, whichever is shorter, Avtron warrants the equipment, except as hereinafter provided, to be free from harmful defects in material and workmanship. Notwithstanding any other term or provision in this Warranty, the warranty provided herein shall terminate unless buyer notifies Avtron, in writing, of a breach hereof within the warranty period; any claims not made within such period are waived by Buyer. The warranty provided herein applies only if Buyer complies with all the other terms and provisions of this Warranty.

## Uses of Equipment

The warranty provided herein applies only if the equipment has been used in a normal and proper manner under recommended conditions. Notwithstanding any advice or assistance given to the Buyer by Avtron or its suppliers concerning the equipment or its use, Avtron makes no express or implied warranties or representations, except as herein expressly provided, with respect to the equipment or its use, and Avtron shall not be liable in contract, warranty or tort (including, without limitation, for negligence or strict liability) as a result of such advice or assistance. In addition, unless otherwise agreed in writing signed by a duly authorized representative of Avtron, no equipment covered by this warranty is intended to be used in connection with any nuclear facility or activity, and if so used, Avtron disclaims any and all liability for any damage resulting therefrom.

## Notification of Breach

When claiming a breach of this Warranty, Buyer must promptly (within 10 days from the date of the discovery of the defect) notify Avtron in writing.

## Equipment Disposition

Upon notification of a claimed breach of this Warranty, Avtron, at its discretion, will either authorize the return of the defective equipment or part thereof (transportation costs to be prepaid by Buyer) or provide a suitable replacement or authorize the Buyer in writing to effect repairs at Avtron's expense. In the event that the equipment returned as authorized is found to be defective and Avtron elects to repair or replace said equipment, Avtron will pay the transportation costs associated with the return of said equipment to Buyer. Avtron shall not however be liable for any customs, tariffs, duties or taxes incurred in shipping equipment pursuant to this Warranty. These shall be the responsibility of the Buyer.

## Option of Avtron to Repair or Replace Equipment or to Issue Credit

Avtron's sole obligation under this Warranty shall be, at the option of Avtron, to replace or repair any defective equipment or part thereof or to issue a credit with respect to the defective equipment equal to the purchase price thereof less depreciation.

**Equipment Excluded From Warranty**

The warranty provided herein specifically excludes equipment and components that Avtron purchases and resells as part of a system, product or spare part order. The warranties provided to Avtron by the manufacturers of the foregoing equipment and components will, to the extent possible, be passed on to the Buyer. Copies of such warranties, if on file at Avtron, will be made available for inspection upon the request of Buyer. Equipment such as, but not limited to, computers, CRTs, operator interface modules, monitors, etc., normally have a short warranty period and should be covered by a continuous service contract generally available from the original manufacturer at a reasonable cost. Consumable items including, but not limited to, lamps, filters, fuses and motor brushes are excluded from all warranties. Other items or components may be excluded from this warranty if so noted in the governing purchase order or contract.

**Resale or Lease of Equipment**

In the event that the Buyer resells or leases equipment purchased from Avtron, the Buyer shall obtain the signed written agreement of the purchaser or lessee thereof that Avtron's only liability with respect to said equipment is as set forth in this Warranty. In the event that the Buyer fails to obtain such a signed written agreement, the Buyer agrees to indemnify Avtron against any claims, demands, judgments, suits, costs, liabilities and expenses (including reasonable attorney's fees) incurred by Avtron as a result of such failure.

**Unauthorized Repairs**

Unless otherwise agreed in writing signed by a duly authorized representative of Avtron, if the Buyer has repairs or modifications made to equipment covered by this Warranty by a person other than an authorized Avtron service representative, Avtron shall not be liable for any expenses incurred in connection therewith and the warranty provided herein shall automatically be terminated.

**Governing Law; Saving Clause**

This Warranty is part of the terms and conditions of the sale of the equipment covered hereunder and shall be governed by and enforced in accordance with the laws of the State of Ohio. Any provision hereof which is prohibited or unenforceable in any jurisdiction shall, as to such jurisdiction, be ineffective to the extent of such prohibition or unenforceability without invalidating the remaining provisions hereof or affecting the validity or enforceability of such provision in any other jurisdiction.

**Limitation of Liability**

**IN NO EVENT SHALL AVTRON BE LIABLE IN CONTRACT, IN TORT OR OTHERWISE FOR SPECIAL, INCIDENTAL, CONSEQUENTIAL OR PUNITIVE DAMAGES (INCLUDING, BUT NOT LIMITED TO, LOSS OF PROFITS OR REVENUES, LOSS OF USE OF THE EQUIPMENT OR ANY DAMAGE TO ASSOCIATED EQUIPMENT, DAMAGE OR INJURY TO PERSONS OR PROPERTY, COST OF CAPITAL, COST OF SUBSTITUTE OR TEMPORARY EQUIPMENT, DOWNTIME OR CLAIMS OF CUSTOMERS) ARISING OUT OF OR AS A RESULT OF BREACH OF WARRANTY, DEFECT IN MATERIAL OR WORKMANSHIP OR ANY OTHER OBLIGATION OF AVTRON HEREUNDER.**

**Disclaimer of All Other Warranties**

THIS WARRANTY COMPRISES AVTRON'S SOLE AND ENTIRE WARRANTY OBLIGATION TO BUYER, ITS CUSTOMERS AND ASSIGNS IN CONNECTION WITH EQUIPMENT SOLD, ASSIGNED, LEASED OR OTHERWISE DEALT WITH BY AVTRON. ALL OTHER WARRANTIES, EXPRESS OR IMPLIED, INCLUDING, BUT NOT LIMITED TO, WARRANTIES OF MERCHANTABILITY AND FITNESS, ARE EXPRESSLY EXCLUDED.



AVTRON AEROSPACE, INC. • AVTRON INDUSTRIAL AUTOMATION, INC. • AVTRON LOADBANK, INC.