

INSTRUCTION MANUAL

PARTS #: 77217

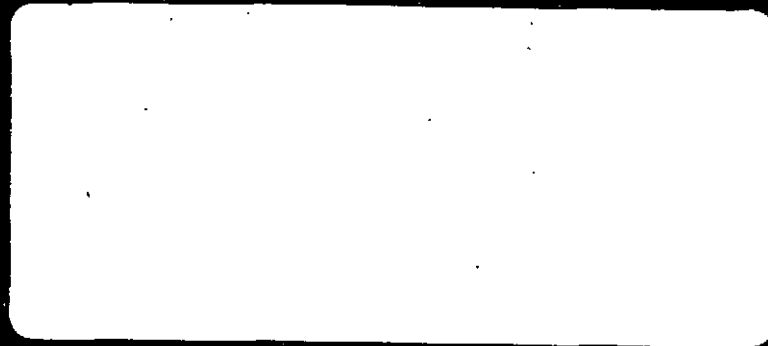

Specialists in the Following Services for Industry

**DIGITAL MEASUREMENT AND CONTROL SYSTEMS
TEST EQUIPMENT FOR AIRCRAFT ELECTRICAL AND HYDRAULIC COMPONENTS
RESISTIVE AND REACTIVE LOAD BANKS
ROTARY PULSE GENERATORS**



All Sales and Service for
Aircraft Test Equipment:
7900 E. Pleasant Valley Rd.
Independence, Ohio 44131-5529
TELEPHONE (216) 642-1230
FACSIMILE (216) 642-6037

Service for All
Other Products:
10409 Meech Ave.
Cleveland, Ohio 44105-4183
TELEPHONE (216) 641-8310
FACSIMILE (216) 341-8803

AVTRON MODEL K775
OUTDOOR LOAD BANK
Part Number K775D16930

Maximum 60 KW @ 208V, 3-Phase,
4-Wire Load Bank,
5, 10, 15, 15, 15 KW Steps

PROPRIETARY NOTE

This document contains information PROPRIETARY to Avtron Manufacturing, Inc., is furnished solely to provide information sufficient for instruction, operation, maintenance, evaluation, and testing of the equipment herein disclosed, is not to be used for manufacturing or procurement and is not to be disclosed to anyone other than persons in the Division, or the Company, or the Government, as the case may be, responsible for action relating to this document without the express written permission of Avtron Manufacturing, Inc.

WARRANTY

The last page of this document contains an express limited warranty. The provisions of this warranty cover any and all rights extended to holders of Avtron equipment.

AVTRON MODEL K775
OUTDOOR LOAD BANK
Part Numbers K775D16431 thru K775D16440
and
Part Numbers K775D16929 thru K775D16935

Maximum 75KW @ 240 Volts, 3-Phase, 4 Wire Load Bank,

or

Maximum 75KW @ 480 Volts, 3-Phase, 4 Wire Load Bank

or

Maximum 75KW @ 208 Volts, 3-Phase, 4 Wire Load Bank

© 1983 Avtron Manufacturing, Inc.
Cleveland, Ohio

April 8, 1983
Rev. April 18, 1988
Rev. July 17, 2002

AVTRON MANUFACTURING, INC.
Cleveland, Ohio

AVTRON MODEL K775
LOAD BANK
Part Numbers K775D16431 thru K775D16440 and
Part Numbers K775D16929 thru K775D16935

TABLE OF CONTENTS

<u>Section</u>		<u>Page</u>
I	SAFETY CONSIDERATIONS	1-1
II	DESCRIPTION	2-1
III	INSTALLATION	3-1
IV	OPERATION	4-1
V	MAINTENANCE	5-1
VI	MODEL K775 LOAD BANK OPTIONS	6-1
	(Drawings for options are listed at the end of the Table of Contents.)	
VII	REPLACEMENT PARTS LIST	7-1

APPENDIX - Avtron Load Bank Troubleshooting Guide

DRAWINGS

<u>LOAD BANK</u>	<u>OUTLINE DRAWING</u>	<u>SCHEMATIC</u>	<u>W/D</u>	<u>CONTROL PANEL W/D</u>
D16431	SB1372	D16451	D16441	C16197
D16432	SB1372	D16452	D16442	C16275
D16433	SB1372	D16453	D16443	C16276
D16434	SB1372	D16454	D16444	C16277
D16435	SB1372	D16455	D16445	C16278
D16436	SB1372	D16456	D16446	C16197
D16437	SB1372	D16457	D16447	C16275
D16438	SB1372	D16458	D16448	C16276
D16439	SB1372	D16459	D16449	C16277
D16440	SB1372	D16460	D16450	C16278
D16929	SB1372	D16954	D16949	C16278
D16930	SB1372	D17554	D16950	C16278
D16931	SB1372	D17643	D16951	C16276
D16932	SB1372	D18025	D16952	C16275
D16933	SB1372	D18024	D16953	C16197
D16934	SB1372	D18393	D18394	C17783
D16935	SB1372	D18767	D18766	C18133

AVTRON MODEL K775
OUTDOOR LOAD BANK
Part Numbers K775D16431 thru K775D16440
and
Part Numbers K775D16929 thru K775D16935

SECTION I

SAFETY CONSIDERATIONS

Throughout this manual, you will find **WARNING** and **CAUTION** statements. Personal injury to an operator using or repairing the equipment may occur if the **WARNING** statement is ignored. Damage to the equipment and potentially hazardous conditions for personnel may occur if the **CAUTION** statement is ignored.

Each Avtron unit is safety checked for opens and shorts, and the insulation is high potential tested to ensure safe operation. All fuses, safety interlocks, and related safety equipment have been tested as part of the testing procedure of each unit.

As part of your safety program, an initial inspection after receiving the unit(s) and periodic preventive maintenance and safety inspections should be conducted to ensure the reliability and safety that have been built into your Avtron equipment.

K775 Safety Considerations

The Model K775 Load Bank is an industrial test unit designed to be installed outdoors. However, because the function of the load bank is to dissipate electrical energy, there is inherent danger to the operator and to the equipment. These dangers shall be outlined in this section.

Electrical energy is transformed into heat by the resistor elements. The heat is removed from the load bank by airflow through the resistor elements. If there are any restrictions or stoppage of airflow, the load bank may overheat and may even start a fire. The following recommendations are made:

1. Read the manual before operating the load bank.
2. Using an approved ground wire, connect the load bank ground lug, located inside relay panel enclosure, to the generator frame. Using an approved ground wire, connect the generator frame to a good earth ground. (Refer to the following table.)

70-116

NATIONAL ELECTRICAL CODE

Table 250-95. Minimum Size Equipment Grounding Conductors for Grounding Raceway and Equipment

Rating or Setting of Automatic Overcurrent Device in Circuit Ahead of Equipment, Conduit, etc., Not Exceeding (Amperes)	Size	
	Copper Wire No.	Aluminum or Copper-Clad Aluminum Wire No. *
15	14	12
20	12	10
30	10	8
40	10	8
60	10	8
100	8	6
200	6	4
300	4	2
400	3	1
500	2	1/0
600	1	2/0
800	0	3/0
1000	2/0	4/0
1200	3/0	250 MCM
1600	4/0	350 "
2000	250 MCM	400 "
2500	350 "	600 "
3000	400 "	600 "
4000	500 "	800 "
5000	700 "	1200 "
6000	800 "	1200 "

* See installation restrictions in Section 250-92(a).

NOTE: This information is provided only for reference. For complete information, refer to applicable sections of the NEC.

Taken from National Electrical Code® 1987

3. Do not bypass the airflow safety switch to prevent nuisance tripping. The switch will drop out the load if sufficient cooling air is not reaching the elements.
4. Replace any burned out bulbs on the Control Panel. Each lamp is an indication that a system is active or has failed and is important to the operation of the facility and safety of the operator.
5. Maintenance should be performed with no power on the unit. The majority of troubleshooting can be performed with an ohmmeter. There are multiple sources of power input to the load bank. Ensure each is disconnected. Personal injury from electrical shock may result if all sources of power are not disconnected before servicing. Maintenance work must be done only by qualified personnel.
6. Venting the heated air from the exhaust toward overhead cables, sprinkler systems, or onto a wall or roof is a potential hazard. The load bank should be used in a cool, well ventilated area.
7. Do not allow the unit to be placed where hot exhaust air can recirculate back through the unit causing a constant rise in cooling air temperature.
8. After running a load test, allow the air to flow through the resistor elements for a few minutes to exhaust accumulated heat.
9. The operator should avoid coming in contact with the resistor elements or surrounding covers during and for some time after operation. These portions of the load bank become quite hot and may result in a serious burn should contact be made with them.
10. Do not allow objects to enter or block the air intake or exhaust of the load bank. A blockage would cause load bank overheating. If an object enters the screens, it will cause damage to the resistor elements, possibly shorting them and causing shock and fire hazards.
11. Emergency Shutdown Procedure:
 - A. In an emergency, shut down the Master Load switch, then the generator. The Master Load switch will disconnect all load steps and still allow the fan motor to run, cooling any heated elements.

- B. The power ON/OFF switch will disconnect both load steps and fan motor. The Generator Emergency "OFF" switch should be located near the load system.
12. An approved electrical fire extinguisher should be on hand at all times.
 13. It is the responsibility of the customer to take diligent care in installing the load bank. The National Electrical Code (NEC), sound local electrical and safety codes, and the Occupational Safety and Health Act (OSHA) should be followed when installing the equipment to reduce hazards to persons and property. (Refer to the following tables for additional information.)
 14. Read and heed all **WARNING** and **CAUTION** statements in the manual.

ARTICLE 310 — CONDUCTORS FOR GENERAL WIRING 70-153

Table 310-16. Ampacities of Not More than Three Single Insulated Conductors, Rated 0 through 2000 Volts, in Raceway in Free Air and Ampacities of Cable Types AC, NM, NMC and SE Based on Ambient Air Temperature of 30°C (86°F):

Size	Temperature Rating of Conductor. See Table 310-13.								Size
	60°C (140°F)	75°C (167°F)	85°C (185°F)	90°C (194°F)	90°C (194°F)	75°C (167°F)	85°C (185°F)	90°C (194°F)	
	TYPES TW, UF	TYPES (FEPW, RHL, TRHW, THW, THWN, XHHW, USE, ZW)	TYPE V	TYPES TA, TBS, SA, AVB, BS, FEP, TRH, TRHW, XHHW	TYPES TW, UF	TYPES RHL, TRHW, THW, THWN, XHHW USE	TYPE V	TYPES TA, TBS, SA, AVB, BS, RHL, TRHW, XHHW	
	COPPER				ALUMINUM OR COPPER-CLAD ALUMINUM				
18	14
16	18	18
14	20†	20†	25	25†
12	25†	25†	30	30†	20†	20†	25	25†	12
10	30	35†	40	40†	25	30†	30	35†	10
8	40	50	55	55	30	40	40	45	8
6	55	65	70	75	40	50	55	60	6
4	70	85	95	95	55	65	75	75	4
3	85	100	110	110	65	75	85	85	3
2	95	115	125	130	75	90	100	100	2
1	110	130	145	150	85	100	110	115	1
1/0	125	150	165	170	100	120	130	135	1/0
2/0	145	175	190	195	115	135	145	150	2/0
3/0	165	200	215	225	130	155	170	175	3/0
4/0	195	230	250	260	150	180	195	205	4/0
250	215	255	275	290	170	205	220	230	250
300	240	285	310	320	190	230	250	255	300
350	260	310	340	350	210	250	270	280	350
400	280	335	365	380	225	270	295	305	400
500	320	380	415	430	260	310	335	350	500
600	355	420	460	475	285	340	370	385	600
700	385	460	500	520	310	375	405	420	700
750	400	475	515	535	320	385	420	435	750
800	410	490	535	555	330	395	430	450	800
900	435	520	565	585	355	425	465	480	900
1000	455	545	590	615	375	445	485	500	1000
1250	495	590	640	665	405	485	525	545	1250
1500	520	625	680	705	435	520	565	585	1500
1750	545	650	705	735	455	545	595	615	1750
2000	560	665	725	750	470	560	610	630	2000
AMPACITY CORRECTION FACTORS									
Ambient Temp. °C	For ambient temperatures other than 30°C (86°F), multiply the ampacities shown above by the appropriate factor shown below.								Ambient Temp. °F
21-25	1.08	1.05	1.04	1.04	1.08	1.05	1.04	1.04	70-77
26-30	1.00	1.00	1.00	1.00	1.00	1.00	1.00	1.00	79-86
31-35	.91	.94	.95	.96	.91	.94	.95	.96	88-95
36-40	.82	.88	.90	.91	.82	.88	.90	.91	97-104
41-45	.71	.82	.85	.87	.71	.82	.85	.87	106-113
46-50	.58	.75	.80	.82	.58	.75	.80	.82	115-122
51-55	.41	.67	.74	.76	.41	.67	.74	.76	124-131
56-6058	.67	.7158	.67	.71	133-140
61-7033	.52	.5833	.52	.58	142-158
71-8030	.4130	.41	160-176

† Unless otherwise specifically permitted elsewhere in this Code, the overcurrent protection for conductor types marked with an obelisk (†) shall not exceed 15 amperes for 14 AWG, 20 amperes for 12 AWG, and 30 amperes for 10 AWG copper; or 15 amperes for 12 AWG and 25 amperes for 10 AWG aluminum and copper-clad aluminum after any correction factors for ambient temperature and number of conductors have been applied.
 * For dry and damp locations only. See 75°C column for wet locations.

NOTE: This information is provided only for reference. For complete information, refer to applicable sections of the NEC.

Taken from National Electrical Code® 1987

8. Ampacity Adjustment Factors.

(a) **More than Three Conductors in a Raceway or Cable.** Where the number of conductors in a raceway or cable exceeds three, the ampacities given in Tables 310-16, 310-18, 310-22, 310-26, 310-27, 310-28, 310-29, 310-30, and 310-31 shall be reduced as shown in the following table:

70-168

NATIONAL ELECTRICAL CODE

Number of Conductors	Percent of Values in Tables 310-16, 310-18, 310-22, 310-26, 310-27, 310-28, 310-29, 310-30, and 310-31, as Adjusted for Ambient Temperature if Necessary
4 thru 6	80
7 thru 9	70
10 thru 24*	70
25 thru 42*	60
43 and above*	50

* These factors include the effects of a load diversity of 50 percent.

NOTE: This information is provided only for reference. For complete information, refer to applicable sections of the NEC.

Taken from National Electrical Code® 1987

SECTION II

DESCRIPTION

The Model K775 Load Bank is an outdoor, self-contained unit for electrically loading and testing of generators.

The loading capability is fixed for certain KW steps. See table below for step resolution. See Table 1 for all Load Configurations and Capabilities.

The load is configured in a four wire, three phase, wye connected circuit with the fixed loads being controlled by three pole contactors.

MODEL NO.	PART NO.	KW	VOLTAGE	STEPS	CONTROL PANEL
K775	D16431	15	240	1-15 KW	C16188
K775	D16432	30	240	2-15 KW	C16189
K775	D16433	45	240	3-15 KW	C16190
K775	D16434	60	240	4-15 KW	C16191
K775	D16435	75	240	5-15 KW	C16192
K775	D16436	15	480	1-15 KW	C16188
K775	D16437	30	480	2-15 KW	C16189
K775	D16438	45	480	3-15 KW	C16190
K775	D16439	60	480	4-15 KW	C16191
K775	D16440	75	480	5-15 KW	C16192
K775	D16929	75	208	5-15 KW	C16192
K775	D16930	60	208	5, 10, 15 15, 15 KW	C16650
K775	D16931	45	208	3-15 KW	C16653
K775	D16932	30	208	2-15 KW	C17497
K775	D16933	15	208	1-15 KW	C17496
K775	D16934	45	208	5, 10, 15 15 KW	C17703
K775	D16935	60	240/ 480V	4-15 KW	C18096

Control Panel

A separate control panel is provided with each load bank. The control panel is a 19" rack mountable panel suitable for indoor use only.

1. POWER ON switch applies power to the control circuit.
2. POWER ON indicator shows an amber light when power is applied to the control circuit.
3. BLOWER ON switch applies power to the blower motor.
4. BLOWER FAIL indicator shows a red light when there is insufficient airflow through load bank to cool the elements.
5. FUSE. A fuse is used to protect the control circuit.

C A U T I O N

DO NOT operate the load bank over the rated voltage as this will cause catastrophic failure in the load bank.

DO make sure that the VOLTAGE SELECT switch is in the proper position before applying load.

6. VOLTAGE SELECT switch (dual voltage units only) configures the load bank for the required test.
7. MASTER LOAD switch allows instantaneous connection and disconnection of all switched on LOAD STEP switches.
8. LOAD STEP switches connect and disconnect individual loads with values shown above each switch. The LOAD STEP switches can be either preprogrammed before actuation of MASTER LOAD switch or changed after the load is applied.

Enclosure

The Load Bank is shown on outline drawing SB1372 and is 55 inches high, 41 inches deep, and 27 inches wide. The load bank has forklift channels for ease of installation. The relays are enclosed in a gasketed NEMA type box for protection. The enclosure has a thermostatically controlled heater to help prevent condensation.

The screened air intake is located several feet off the bottom of the unit and exhaust is discharged through a louvered screened opening. Reference outline drawing SB1372.

Power Connection

Control and fan power requirements are 120 volts, single phase, 10 amp maximum current draw.

Load power is connected by punching holes into the enclosure and running approved weathertight conduit. Outline drawing SB1372 details conduit entry area.

Attach load cables to insulated standoffs (marked A, B, C & N). The following is a list of drawings for the K775 Load Bank:

LOAD BANK	SCHEMATIC	W/D	CONTROL PANEL	CONTROL PANEL W/D
D16431	D16451	D16441	C16188	C16197
D16432	D16452	D16442	C16189	C16275
D16433	D16453	D16443	C16190	C16276
D16434	D16454	D16444	C16191	C16277
D16435	D16455	D16445	C16192	C16278
D16436	D16456	D16446	C16188	C16197
D16437	D16457	D16447	C16189	C16275
D16438	D16458	D16448	C16190	C16276
D16439	D16459	D16449	C16191	C16277
D16440	D16460	D16450	C16192	C16278
D16929	D16954	D16949	C16192	C16278
D16930	D17554	D16950	C16650	C16278
D16931	D17643	D16951	C16653	C16276
D16932	D18025	D16952	C17497	C16275
D16933	D18024	D16953	C17496	C16197
D16934	D18393	D18394	C17703	C17783
D16935	D18767	D18766	C18096	C18133

Lower voltages and different frequencies may be applied to the load circuit of the load bank. Frequency change causes no derating of the load. Refer to Section IV for derating the load bank at lower voltages.

C A U T I O N

Never exceed the rated voltage as this will cause the load bank to overheat.

Do not apply DC voltages as the contactors do not have arc blowout magnets.

Blower power requirements are 460 volts, three phase, 1 amp maximum current draw. Optional blower voltages are available. Refer to Section VI for more complete information.

50 Hz Operation

The three phase motor can be operated at 50 Hz by reducing the input voltage of 460 volts to 400 volts $\pm 10\%$ or the 230 volts to 200 volts $\pm 10\%$. Since operating at 50 Hz will reduce the blower RPM and thus the airflow, the load bank load voltage must also be reduced from 480 volts to 400 volts or 240 volts to 200 volts.

C A U T I O N

Voltage Applied to the Load Bank must be reduced if the blower motor is operated at 50 Hz.

SECTION III
INSTALLATION

Before Installation

Inspect the load bank for obvious damage such as broken wires, broken or dented panels, cracked ceramic insulators, or any other component breakage that may have occurred in shipment.

Location

Locate Load Bank outdoors using four 3/8 bolts through mounting pad holes. Electrical connections should be made through approved conduit or watertight tubing in location shown on outline drawing. If possible, locate Load Bank so prevailing winds are in the same direction as the airflow through Load Bank.

C A U T I O N

Installation must preclude hot exhaust air from recirculating into air intake. Inlet air temperatures exceeding 120°F may cause damage to the load facility. After installation, test the unit at full load and verify that the inlet air temperature does not exceed 120°F.

The exhaust air may be in excess of 300°F under full load conditions. The unit must not be installed near any equipment or wiring or plumbing which may be damaged by high air temperatures or which may constitute a fire hazard. Care should also be taken so as not to set off sprinkler system by exposing it to hot exhaust air.

Airflow Considerations

Even with an ample supply of cooling air, the load bank may overheat if it is not properly installed. There are two types of airflow problems that should be avoided:

1. Recirculating Airflow - If the hot, exhausted air is permitted to recirculate through the load bank, it will reach such a high temperature and low density that it

will no longer cool the resistance elements. A load bank should not be installed so close to any surface as to reflect the exhausted air back to the air intake. When two or more load banks are being used, care must be taken in positioning the load banks so that the exhausted air of one unit does not feed the air intake of another.

2. Restriction of cooling air - Any obstruction located within four (4) feet of the inlet and exhaust screens will restrict the load bank's airflow. Airflow is also restricted when two or more load banks have air inlets positioned close to each other. This competition for cooling air causes a low pressure area, restricting adequate airflow.

W A R N I N G

It is vitally important to install the load bank properly. Installation errors may result in a catastrophic failure. The Airflow switch, a protective device in the load bank, will guard against some of these problems. If protective circuitry prevents application of the load, determine the source of the problem. DO NOT DISABLE the AIRFLOW SWITCH. This will cause a safety hazard and will void our warranty. The following installation instructions are critical to the safe operation of the load bank. Refer to the Safety Considerations section of this manual.

Power Requirements

The load bank requires a 120 volt, single phase, 60 Hz, 10 amp source of power for operation of the control panel. An optional transformer may be provided to change load power to 120 VAC, single phase. Blower power requirements are 460 volts, 3-phase, 60 Hz. An option will allow the blower to operate at 230 VAC, 3-phase, 60 Hz or 208 volts, 3-phase, 60 Hz.

The generator load connections are insulated standoffs, identified with phase and neutral markers.

Cables to the load bank should be of adequate size to handle maximum rated load according to National Electric Code.

Avtron Model K775

Load Bank

Part Numbers K775D16431 thru K775D16440
and K775D16929 thru K775D16935

The line current can be determined by the following formula:

$$\text{Line Current} = \frac{\text{KW} \times 577}{\text{VOLTAGE (Line to Line)}}$$

A case ground is provided inside the relay panel enclosure and must be connected to the generator frame which in turn should be connected to a good earth ground.

SECTION IV

OPERATION

Purpose and Use of Controls

1. POWER ON Switch, powers control circuit. Amber light shows power ON.
2. BLOWER ON switch applies power to the blower motor.
3. AIR FAIL Lamp. This lamp should momentarily light when the power switch is turned "ON". This shows the air safety circuit is working. This lamp's purpose is to alert the operator in case of an air failure or improper cooling of load elements. The air failure circuit will remove the load applied to the load bank.
4. VOLTAGE SELECT switch. (Dual voltage units only.) This switch selects the required voltage mode for the load bank.
5. MASTER LOAD Switch. The Master Load Switch connects power to all load step switches, thus allowing all load steps which are actuated to be applied at the same time. It is also a master load disconnect.
6. LOAD STEP Switches. The load in kilowatts is marked above each actuating switch. A load step may be turned on or off before or during a test, but will load the unit only when the Master Load Switch is ON.

Load Bank Operation

All tests start with control panel switches in the "OFF" position.

C A U T I O N

Before energizing any load, verify that load voltage does not exceed rated voltage of load bank.

The unit is energized by the "POWER ON" switch. The "BLOWER ON" switch energizes the cooling fan motor. Upon energizing the BLOWER, the red BLOWER FAIL lamp will light momentarily until the air switch detects sufficient cooling air, at which time the lamp

will go out and the load switches will be enabled. If at any time there is insufficient cooling air to the elements, the air switch will drop out the load and the red BLOWER FAIL lamp will light.

After the BLOWER FAIL lamp goes out, throwing the appropriate switch will apply that load, if the MASTER LOAD switch is ON.

C A U T I O N

Do not attempt operation if fan is not running. Fan inlet and exhaust must be unrestricted. The operation of the fan is vital to the safe operation of this load bank. If "AIR LOSS" indicating light comes on and stays on for more than a few seconds without the load dropping out, shut off the power switch at once. Remove all power from the unit and check for proper operation of fan safety circuit. Failure to correct a cooling air loss condition will result in destruction of the load bank and possibly hazardous conditions for operating personnel.

Operating Instructions

1. Place all switches on the Control Panel in the OFF position.
2. Connect load bank to 120 volts, single phase, 60 Hz power source.
3. Connect #2 AWG minimum, wire from load bank frame ground lug to the generator frame.
4. Connect the generator frame to a good earth ground.
5. Connect the appropriate generator leads to the load bank.
6. With control power and Master Load switch "OFF", start the generator.

C A U T I O N

DO NOT operate the load bank over the rated voltage as this will cause catastrophic failure in the load bank.

DO make sure that the VOLTAGE SELECT switch is in the proper position before applying load.

7. Place the VOLTAGE SELECT switch (dual voltage units only) to the proper operating voltage position.
8. Place the control power switch in the "ON" position. The amber "POWER ON" lamp will light. Verify that the red air failure lamp momentarily lights, then, as the blower comes up to speed and trips, the air failure lamp goes out.
9. Position the load selector switches for the desired load.
10. Turn on Master Load switch to apply desired load. Load steps may be added or deleted at any time.
11. After running tests, remove the load by turning off Master Load switch, and allow the cooling blower to run a few minutes to exhaust any accumulated heat.

Load Connections

NOTE

On single voltage or dual voltage units (240 volts), do not exceed 240 volts L to L or 138.6 Volts L to N.

On single voltage or dual voltage units (480 volts), do not exceed 480 volts L to L or 277 volts L to N.

On single voltage unit (208 volts), do not exceed 208 volts L to L or 120 volts L to N.

Above applies to both 3-phase or single phase configuration (see below).

NOTE

Lower voltages and different frequencies may be applied to the load circuit of the load bank. Frequency change causes no derating of the load, however, the actual KW with a lower voltage is computed with the following formula:

TABLE 1

VOLTAGE RATED		
208 UNIT	240 UNIT	480 UNIT
3-Phase 208 VL-L	3-Phase 240 L-L	3-Phase 480 VAC L-L
Single phase 240 L-L	Single phase 277 L-L	Single phase 554 VAC L-L
3-Phase or Single Phase 120 VL-N	3-Phase or Single Phase 138.6 V L-N	3-Phase or Single Phase 277 VAC L-N











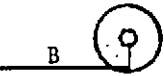
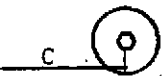





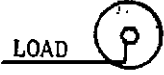



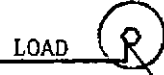

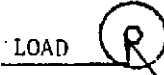

Derate as follows:

$$KW_{Actual} = KW_{Rated} \times \% \text{ CAPACITY} \times \frac{(\text{Voltage Applied})^2}{(\text{Voltage Rated})^{2**}}$$

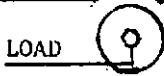
*Refer to Table 2.

**Refer to Table 1.

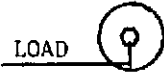
TABLE 2.

	A	B	C	N	CAPACITY AT RATED VOLTAGE*
					3Ø, 4W 100%
					3Ø, 3W 100%
					1Ø, 2W 33%
					1Ø, 2W 66%
					1Ø, 2W 100%
					1Ø, 2W 66%
					1Ø, 3W 66% EDISON CONNECTION

Never exceed the rated voltage as this will cause the load bank to overheat. Refer to Table 1.

Do not apply DC voltages as the contactors do not have arc blowout magnets.

*See Table 1 on Page 4-4.



ESD PRECAUTIONARY GUIDELINES

C A U T I O N

Certain circuit card assemblies and their components, typically integrated circuits, may be damaged by seemingly undetectable electrostatic discharge (ESD). Care must be exercised during handling/repair of these items. Use electrostatic discharge precautionary procedures.

The following guidelines are not necessarily all inclusive but rather serve as reminders for good shop practices for the handling/repair of ESD sensitive circuit card assemblies and devices.

- Store ESD sensitive items in their original containers. These items are often marked with the symbol shown at the top of this page.
- Put on a grounded wrist strap before handling any ESD sensitive item.
- Clear work area of Styrofoam[®]*, plastic, and vinyl items such as coffee cups.
- Handle ESD items by the body, never the open edge connectors.
- Never slide ESD sensitive items over any surface.
- Transport ESD sensitive items in a static shielding container to a static-free work station.
- If a static-free work station is not available, ground the transport container before removing or inserting an ESD item.
- Electric tools used during repair should be grounded. For example, use only anti-static type solder suckers and grounded tip soldering irons. Discharge non-electric tools before use.
- Pack ESD items in static shielding containers before shipping them to Avtron for repair.

* Styrofoam[®] is a registered trademark of Dow Chemical.

SECTION V

MAINTENANCE

To provide long equipment life and to reduce the chance of electric shock, fires, and personal injury, good maintenance procedures must be used. Before servicing, review the Safety Considerations section of this manual.

The following are examples of scheduled maintenance procedures. These examples are not purported to be all-inclusive, but must be accomplished to maintain the equipment in a good, safe condition. All maintenance work must be done by qualified personnel only.

W A R N I N G

Personal injury from electrical shock or from the moving fan blade may result if ALL sources of power are not disconnected. Refer to the Safety Considerations section of this manual.

Daily:

1. Remove any restrictions to airflow through the load bank.
2. Check the screens to make sure that no objects have blocked or entered the openings.
3. Verify that the airflow is in the proper direction.
4. Assure that there is no recirculation of the exhaust air through the load bank.

Three Months or 500 Hours:

1. Remove access panels and screens.
2. Inspect the load resistors for mechanical breakdown which is demonstrated by excessive sagging of the elements. Replace with new resistor elements as required.
3. Inspect for broken ceramic insulators. Replace with a new ceramic insulator if any cracks are found.

4. Inspect for loose hardware or loose connections. Tighten where required.
5. Inspect all connections for oxidation or corrosion. Clean the connection or replace the hardware where required.
6. Verify that the airflow switch works properly.
7. Inspect all magnetic contactors to make sure that the contacts are not severely pitted or corroded. The contacts must move freely and be properly seated.
8. Clean all dirt and debris out of the load bank. This can be accomplished by blowing the inside of the unit with clean, dry compressed air (not to exceed 40 PSI). Eye protection should be worn when cleaning the load bank with compressed air.
9. Inspect all the wiring for any sign of insulation failure.
10. Replace all access panels and screens. Tighten all the fastening hardware securely.
11. Check the indicator lamps on the control panel.

Annually:

The blower motor should be lubricated per the motor manufacturers' requirements and specifications on the motor nameplate.

Parts Replacement

Access to any component is easily made with the removal of the cover panels. All replaceable components in the unit are listed in the replacement parts list. Avtron maintains an inventory of normally used items.

SECTION VI

MODEL K775 LOAD BANK OPTIONS

These options are available for Avtron Model K775 Load Banks. Not all options can be installed in the same unit at the same time.

<u>Option Drawing No.</u>	<u>Option</u>	<u>Description</u>
B16300	1	Installation of 250 VA, 480 V to 120 V Control Transformer (Use only if blower is 3-phase.)
B16301	2	Installation of 240 V, 3-phase Blower Conversion
B16302	3	Installation of 250 VA, 240 V to 120 V Control Transformer
B16303	4	Installation of 120 V, single phase Blower Conversion
B16304	5	Installation of 1.5 KVA, 480 V to 120 V Transformer (To be used with Option 4)
A15725	6	Outdoor Enclosure for Control Panel
SB1405	7	Indoor Enclosure for Control Panel
B18139	8	Installation of a 208 V, single-phase Primary, 120 V Secondary, 250 VA Control Transformer (Use only if blower is 3-phase.)
A18051	9	Mounting of Outdoor Enclosure for Control Panel
B16458	10	Installation of 230 V, single phase, 60 Hz Blower Motor
B16305	11	Installation of 1.5 KVA, 240 V to 120 V Control Transformer (To be used with Option 4)

Avtron Model K775
Load Bank

<u>Option Drawing No.</u>	<u>Option</u>	<u>Description</u>
A20531	12	Installation of Temperature Switch
A23459	13	Installation of Control Unit, Wallmount (NEMA 12 Enclosure for K775 Control Panel and K514D Metering Control Panel).

REPLACEMENT PARTS LIST
O P T I O N S

SCHMATIC REFERENCE	DESCRIPTION	MANUFACTURER and PART NO.	AVTRON P/N	QTY/UNIT
T1	OPTION 01: 250 VA, 480 to 120 V Control Transformer	Acme T-1-53007	B16300	1
	.Transformer		370708	
	.Fuseholder	Bussmann	324992	1
F7	.Fuse, 4A, 500 V	BC60335Q	324454	1
F5,6	.Fuse, 1 A, 500 V	FNQ-R-4	324449	2
		Bussmann FNQ-R-1		
F11,12,13	OPTION 02: 240 V, 3Ø Blower Conversion	Bussmann Type KTK	B16301	3
	.Fuse, 6 Amp, 600 V		324119	
K17	.Relay .Relay, O/L	Telemecanique LR1-D09307	B16148	1
			351523	1
T1	OPTION 03: 250 VA, 240 V to 120 V Control Transformer	Acme Elec. T-1-53007	B16302	1
	.Transformer		370708	
	.Fuseholder	Bussmann	324531	1
F14	.Fuse, 10 A, 250 V	4439 Bussmann FNM	324039	1
B1	OPTION 04: 120 V, 1Ø Blower Conversion	W. W. Grainger 6K122	B16303	1
	.Motor		341067	
F12,13	.Fuse, 12 Amp, 250 V	Littelfuse 523012	324135	2
K17	.Relay .Relay, O/L	Telemecanique LR1-D09314	B14795	1
			350729	1

OPTIONS (Cont.)

SCHEMATIC REFERENCE	DESCRIPTION	MANUFACTURER and PART NO.	AVTRON P/N	QTY/UNIT
	OPTION 05: Installation of 1.5 KVA, 480 V to 120 V Transformer		B16304	
T1	.Transformer	Acme Elec. T53011-A	370593	1
	.Fuseholder	Bussmann 4439	324531	1
F14, F15	.Fuse, 6 Amp, 600 V	Bussmann TRON FNQ	324112	2
	OPTION 08: Installation of 250 VA, 208 V to 120 V Control Transformer		B18139	
T1	.Transformer	Westinghouse 1F1030	370776	1
	.Fuseholder	Bussmann BM6033SQ	324615	1
F14-16	.Fuse, 3 A, 500 V	Bussmann FNQ-R-3	324453	3
	OPTION 10: Installation of 230 V, 1Ø, 60 Hz Blower Motor		B16458	
B1	.Motor	W. W. Grainger 6K122	341067	1
F12, 13	.Fuse, 8 Amp, 250 V	Bussmann FNM	324035	2
K17	.Relay .Relay, O/L	Telemecanique LR1-D09310	B16148 350728	1 1
	OPTION 11: Installation of 240 V TO 120 V Control Transformer		B16305	
T1	.Transformer	Acme Elec. T53011-A	370593	1
	.Fuseholder	Bussmann 4439	324531	1
F14, F15	.Fuse, 10 A, 250 V	Bussmann FNM	324039	2

OPTIONS (Cont.)

SCHEMATIC REFERENCE	DESCRIPTION	MANUFACTURER and PART NO.	AVTRON P/N	QTY/ UNIT
	<p>OPTION 12: Installation of Temperature Switch .Switch, Thermostatic: w/mtg. bracket, range 500°F ±25°F, 60°F mean differen- tial, SPST NC, 15 A, 120 VAC</p>	<p>Elmwood Sensors 3450RC W/201B Per Descr.</p>	<p>360873</p>	<p>1</p>

Avtron Model K775
 Load Bank
 Part Number K775D16930
 S/N 185 and Up

REPLACEMENT PARTS LIST

SCHEMATIC REFERENCE	DESCRIPTION	MANUFACTURER and PART NO.	AVTRON P/N	QTY/ UNIT
	AVTRON MODEL K775, LOAD BANK		D16930	
	.Schematic		D17554	REF
	.Sub-Assembly, Load Bank		D30846	1
B1	..Motor	W. W. Grainger 2N865	341065	1
	..Fuseholder	Bussmann BM6033SQ	324615	1
F11,12,13	..Fuse, 6 Amp, 600V	Bussmann KTK-6	324119	3
	..Impeller, Fan	Air Turbine S-18-11	406022	1
HR1	..Heating Element	Chromalox SN-910 PCN 132919	352026	1
K16,17	..Relay		B17839	2
K18	..Relay*	Telemecanique LR2D1307	351523	1
	..Mounting Bracket*	Telemecanique LA7D1064	408170	1
	..Mounting Bracket*		A15971	1
S1	..Switch, Temp.		A13510	1
S2	..Switch, Press.	Dwyer 1910-00	360770	1
	..Adapter	Crawford S400-1-2	434812	1
	..Wiring Diagram		C16204	1
	.Resistor Assembly		D16940	1
	..Resistance Element		605482	9
	..Resistance Element		605561	6
	..Resistance Element		605476	36
	.Control Panel		D30847-6	1
	.Schematic		D17554	REF
F1	..Fuse, 10 Amp	Littelfuse 314010	324038	1
	..Fuseholder	Littelfuse 342004	324537	1
DS1	..Light, Indicator	Dialight 502-3214-0113-302	329138	1
DS2	..Light, Indicator	Dialight 502-3214-0111-302	329136	1
	..Lamp	General Electric 6S6-125V	333011	2
S1-5,15-17	..Switch, Toggle	Arrow Hart 81024-GB	360599	8

APPENDIX

LOAD BANK TROUBLESHOOTING GUIDE

NOTE

Servicing should always be done only by trained, qualified service technicians.

W A R N I N G

Be sure that all sources of power to the Load Bank are disconnected before servicing.

PROBLEM	POSSIBLE CAUSES/REMEDIES
1. Load Bank main power fails to come on.	<ul style="list-style-type: none"> a. Main switch or circuit breaker is not closed. b. Unit is not connected according to the Schematic/Interconnection Diagram. c. Terminals were damaged during shipment. d. Fuses are blown. (Check and replace as required.)* e. Fuse is blown in Load Bank control circuit. (Check and replace as required.)* f. Dirty or loose connection at Main Power Switch.
2. Blower motor does not operate.	<ul style="list-style-type: none"> a. Main switch or circuit breaker is not closed. b. Power is not connected to Load Bank blower circuit. c. External power source is inadequate. d. Motor fuses are blown. (Check and replace as required.)*

* When checking fuses for continuity, be sure to remove all fuses from clips (in fuseblock or Disconnect Switch). Test each fuse individually, out of circuit. (If tested in circuit, there is the possibility of feedback which causes false readings. A blown fuse may still check out OK.)

PROBLEM	POSSIBLE CAUSES/REMEDIES
2. Blower motor does not operate. (Cont.)	<ul style="list-style-type: none"> e. Motor overload is tripped. f. Motor start is malfunctioning. g. Main Power Switch is inoperative. h. Connections are broken or loose. i. Motor shaft does not turn due to improper lubrication. (Replace or repair as necessary.)
3. BLOWER FAILURE indicator lights, yet blower is operating.	<ul style="list-style-type: none"> a. Airflow restrictions present at Load Bank intake or exhaust. b. Improper fan blade rotation or phase reversal. (Check fan motor power connections for proper phase sequence.) c. Air Differential Pressure Switch is malfunctioning. d. Blower Fail Relay is malfunctioning.
4. Fan blade is broken or not turning.	<ul style="list-style-type: none"> a. Fan blade motion is obstructed. b. Fan blade is loose at hub or is not keyed properly.
5. Load step(s) cannot be energized.	<ul style="list-style-type: none"> a. A blower failure exists. (See problem 2.) b. MASTER LOAD Switch is inoperative. c. Control power is inadequate. d. Fuse is blown in Load Bank control circuit or individual branch circuit load fuse (if so equipped) is blown. (Check and replace as required.)* e. Blower Fail Relay is malfunctioning. f. Load step switch is inoperative. g. Load step contactor is inoperative. h. Magnetic contactor has an open coil. i. Load step resistor is open.

* When checking fuses for continuity, be sure to remove all fuses from clips (in fuseblock or Disconnect Switch). Test each fuse individually, out of circuit. (If tested in circuit, there is the possibility of feedback which causes false readings. A blown fuse may still check out OK.)

PROBLEM	POSSIBLE CAUSES/REMEDIES
6. Contactor "chattering" exists.	<ul style="list-style-type: none"> a. Contacts and/or core are dirty or corroded. b. Connections to contactor coil are loose. c. Control circuit line voltage is too low.
7. Load Bank or load step does not give rated load.	<ul style="list-style-type: none"> a. Applied load voltage is either derated or inadequate. b. Contactor does not close properly. c. Load step resistor element is open. d. One of the individual load branch circuit fuses is blown (if so equipped).
8. Disconnect Switch fuses are blown.	<ul style="list-style-type: none"> a. Fuses are undersized.* b. A short circuit exists in the blower or control circuit.*

* When checking fuses for continuity, be sure to remove all fuses from clips (in fuseblock or Disconnect Switch). Test each fuse individually, out of circuit. (If tested in circuit, there is the possibility of feedback which causes false readings. A blown fuse may still check out OK.)

DRAWINGS

PROPRIETARY NOTE

The wiring diagrams and schematics which follow contain information PROPRIETARY to Avtron Manufacturing, Inc., are furnished solely to provide information sufficient for instruction, operation, maintenance, evaluation, and testing of the equipment herein disclosed, are not to be used for manufacturing or procurement and are not to be disclosed to anyone other than persons in the Division, or the Company, or the Government, as the case may be, responsible for action relating to this document without the express written permission of Avtron Manufacturing, Inc.

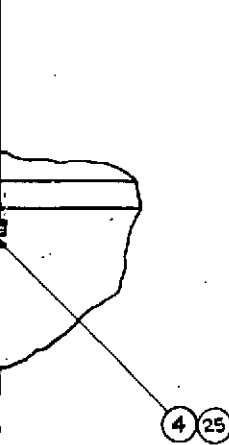

29 30 ON D16937
LINE DRILL AND
MOUNT USING
6-32 HDW.

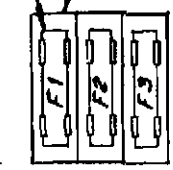

DETAIL A
SCALE: 1/1

REVISIONS				
ECN NO.	LTR.	DESCRIPTION	DATE	APPROVED
	A	ADDED DATA FOR D16930	12-6-74	DMC
	B	ADDED DATA FOR D16931	2-4-75	R.S.
Y305Z	C	D16929, D16930, D16931 ADDED ITEM 9 MOUNT	3-4-75	D.M.P.
	D	ADDED DATA FOR D16932 & 33. J.J.P.	10-25	A.P.
	E	ADDED DATA FOR D16934	10-25	A.P.
	F	ADDED DATA FOR D16935	10-25	A.P.
Y5384	G	ADDED DATA FOR D16936	11-1-75	A.P.
Y8215	H	ADDED DATA FOR D16937	1-21-76	A.P.
Z1079	J	ADDED ITEM 31	9-22-79	A.P.
Z4385	K	ITEM 9 FOR D16929 & D16930 WAS 5 REQD	12-12-79	A.P.
Z4439	L	REVISED ITEMS 21-24 PER ECN	12-12-79	A.P.
Z6057	M	DELETED K9 BLOCK, CHANGED K18 BLOCK TO K9	1-1-80	A.P.
Z6086	N	D16929 THRU D16931 & D16934, D16935 ITEM 7 QTY WAS 14. D16936 ITEM 7 QTY WAS 8. D16929 THRU D16938 ITEM 24 QTY WAS 516096.	1-1-80	A.P.
Z1520	P	ITEM 21 QUANTITY WAS 509813 - .50 L4-	1-1-80	A.P.
Z8375	R	ITEM 31 QTY WAS: 2E1	1-1-80	A.P.
CC068	T	D16929 THRU D16935 ITEM 1 WAS FACKELMANN D16421, D16929 ITEM 3 WAS C16192, ITEM 10 WAS D16949, D16930 ITEM 3 WAS C16650, ITEM 10 WAS D16950, D16931 ITEM 3 WAS C16653, ITEM 10 WAS D16951, D16932 ITEM 3 WAS C16477, ITEM 10 WAS D16952, D16933 ITEM 3 WAS C16496, ITEM 10 WAS D16953.	3-2-00	A.P.

NO.	REF DES	NO. REQD	PART NO.	REF DES	NO. REQD	PART NO.	REF DES	NO. REQD	PART NO.	ITEM NO.	NO. REQD	PART NO.	DESCRIPTION	MATERIAL	DISPOSITION
							31	1	C16202				PLATE, DES	SCOTCHCAL	
							30						FUSEHOLDER		
							29						FUSE 1/2 A		
							28						TRANSFORMER		
							27						TRANS DUCCER		
							26						CONTACT, AUX		
							25	4	540213				RIVET, BLIND		
							24	4	516106				NUT, HEX *10-24	SST	
							23	4	532579				WASHER, LOCK *10	SST	
							22	8	530073				WASHER, FLAT *10	SST	
							21	4	509821				SCREW, PNH, *10-24-62	SST	
							20		520960				NUT, SHT SPR *8-32		
							19		532503				WASHER, LOCK *8	STL CD PL	
							18		530046				WASHER, FLAT *6	STL CD PL	
							17		509127				SCREW, PNH, *8-32-75	STL CD/NKL PL	
							16						WIRE, ELEC, *6 AWG		
							15						WIRE, ELEC, *12 AWG		
							14		390008				WIRE, ELEC, *16 AWG		
							13		390019				WIRE, ELEC, *8 AWG		
							12		390021				WIRE, ELEC, *4 AWG		
							11						SCHEMATIC		
							10	1					WIRING DIAGRAM		
							9		366037				TERMINAL, LUG		
							8						RELAY		
							7		471816				SEAL, WIRE		
							6		416518				PLUG I		
							5						RELAY	SEE NOTE 6	
							4	1	A94595				PLATE, IDENT	B14801	
							3	1					CONTROL PANEL		
							2	1					RESISTOR ASSEMBLY		
							1	1					SUBASSEMBLY, L.B.		

NO.	REF DES	NO. REQD	PART NO.	REF DES	NO. REQD	PART NO.	REF DES	NO. REQD	PART NO.	ITEM NO.	NO. REQD	PART NO.	DESCRIPTION	MATERIAL	DISPOSITION
32	K775D16931			K775D16930			K775D16929						LIST OF MATERIAL		
VAC	45 KW, 208 VAC			60KW, 208 VAC			75 KW, 208 VAC						DRAWN: WOODARD DATE: 3-8-84		
													CHECKED: D.M.C. DATE: 3-9-84		
													AVTRON 16400 BEECH AVENUE CLEVELAND, OHIO 44108		
													LOAD BANK, RESISTIVE (OUTDOOR) (OUTLINE DWG SB1372) PSF		
													SIZE: D CODE IDENT NO: 01014 DRAWING NO: K775D16929 THRU K775D16938 REV: T		
													SCALE: 1/8 MOD: K775 SHEET: 1		

TRANS DUCCER ITEM 27
8, PER P.E. INSTRUCTIONS.
STAND OFFS "A", "B" & "C"
, "CT2" & "CT3".

K17 & AUX. CONTACT ON
W "K17" ITEM 8 AND NEW

PRODUCTION PRINT

NEXT ASSY USED ON APPLICATION

SCAN

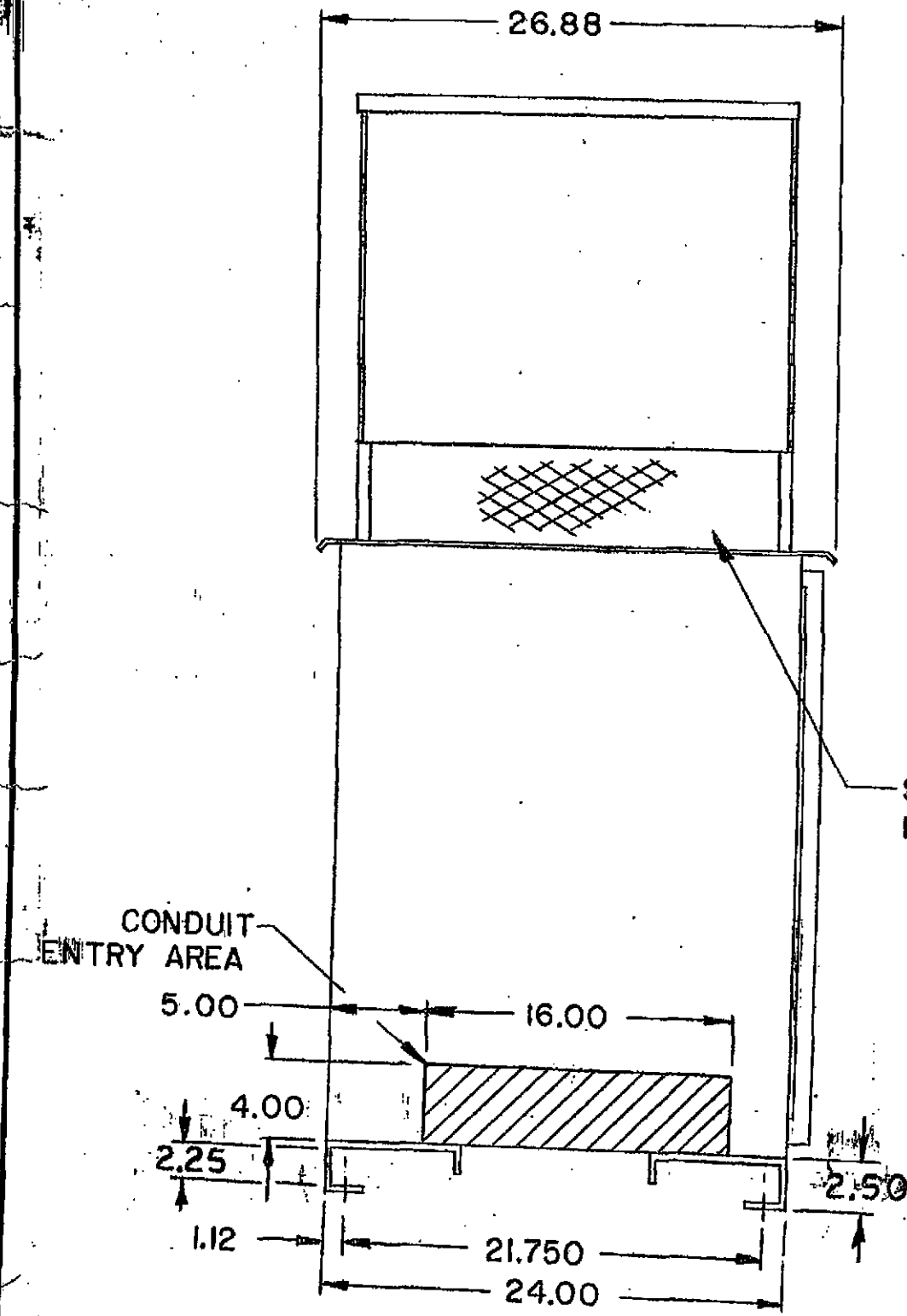

5

.531 DIA
4 HOLES

2. ALL DIMENSIONS ARE APPROX.
1. WEIGHT: 365 LBS

NOTES:

2478	B	35.25 WAS 30.000	38
		WAS 3.50	B. WOODS
	A	ADDED 2.25 & 2.50 MM	
CHG. NO.	LOC.	DATE	CHANGE

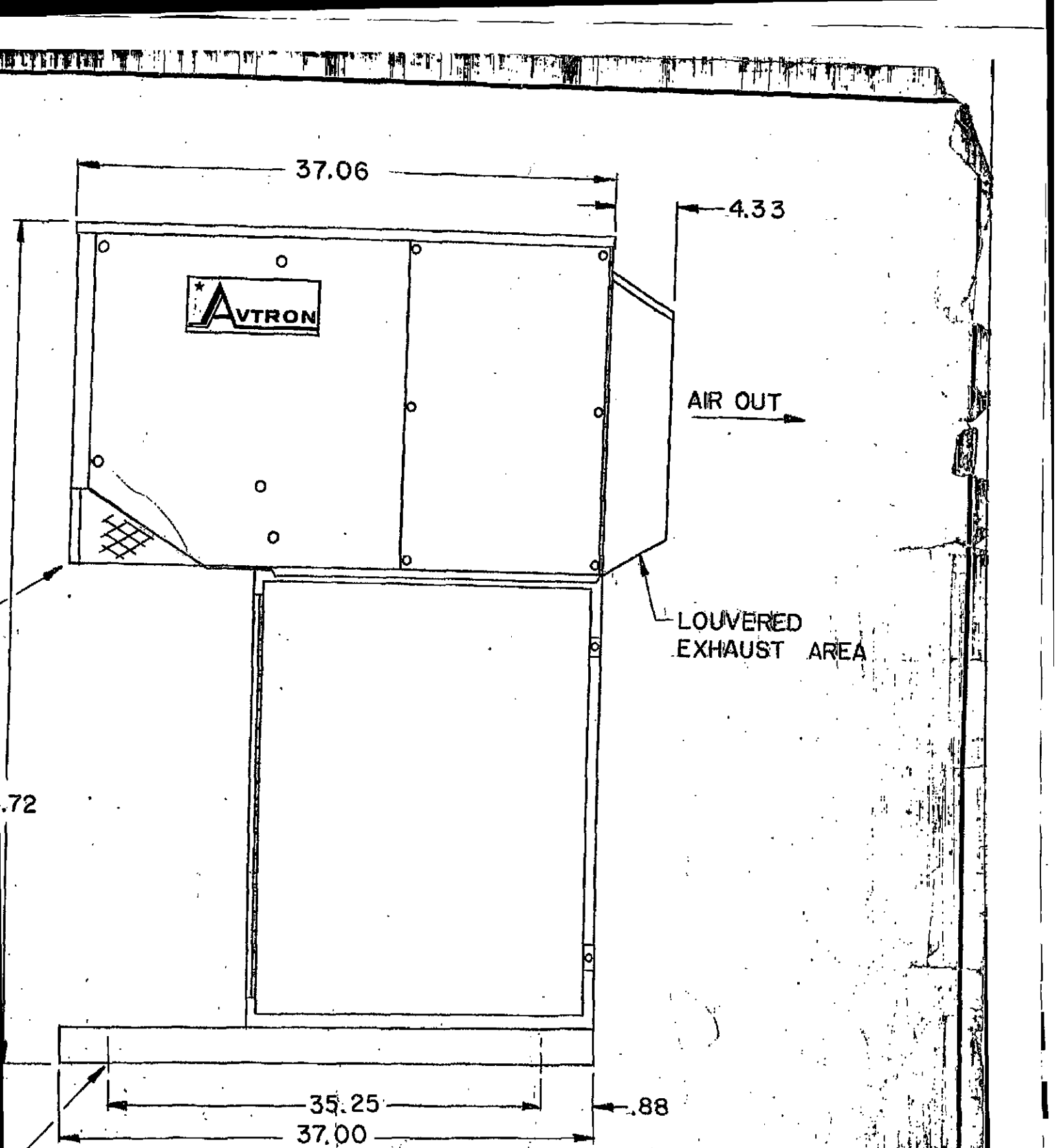

FOR APPLICATION ENGINEERING USAGE ONLY

7/16/91	7/16/91	DRAWN	KS	DATE	3-2-83	 <small>Manufacturing Inc.</small> <small>CLEVELAND, OHIO</small>	DRAWING NUMBER	SB1302 SCAN
12-18-85	12-18-85	CHECKED						
CHG'D	CHK'D	APPROVED	W.P.	SCALE	1/8	LOAD BANK (OUTDOOR)	OUTLINE DRAWING	DWG. SIZE
			MODEL	K775				

LOAD BANK

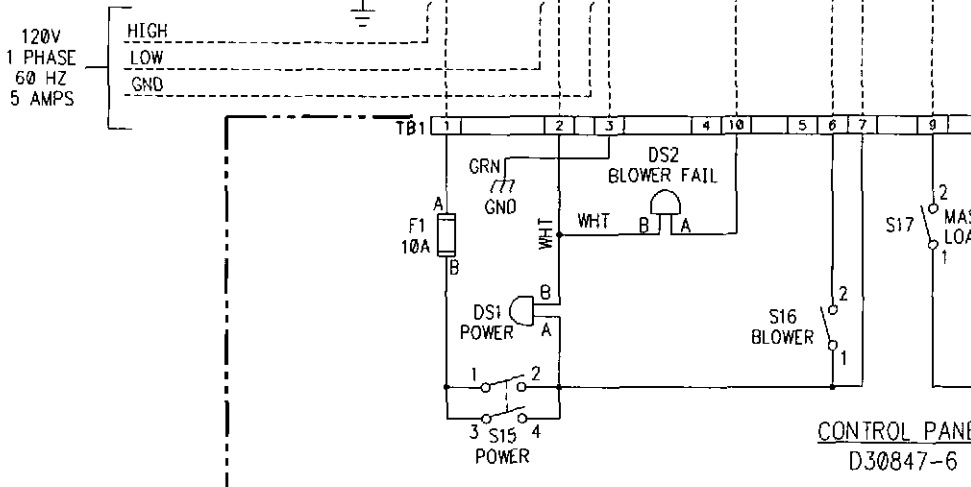
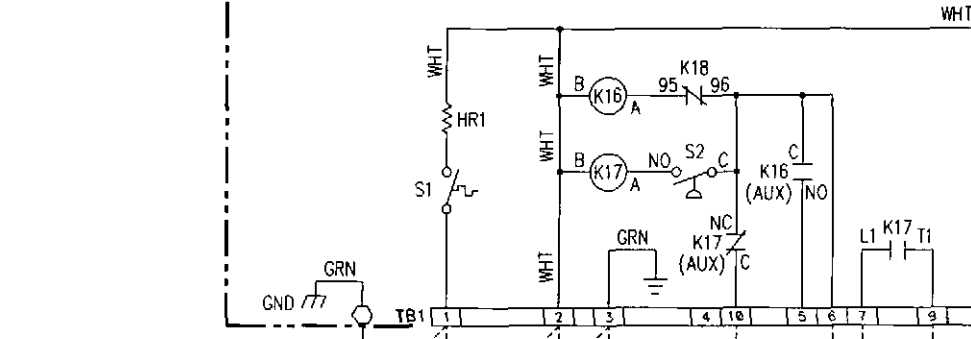
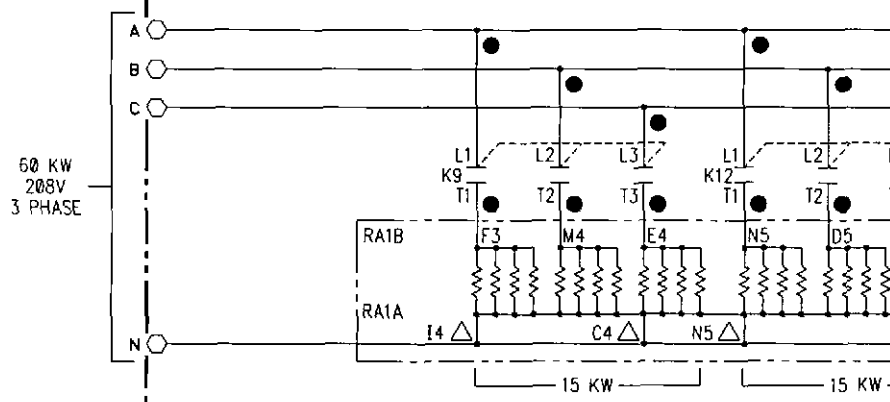
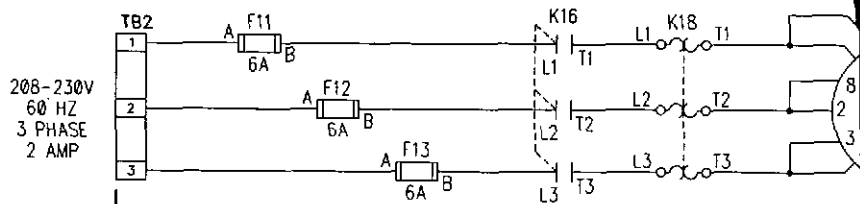

CONTROL PANE
D30847-6

5. WIRE CODE:
UNLESS OTHERWISE NOTED ALL WIRE TO BE BLACK #16 AWG (PN 390008).
● - INDICATES WIRE TO BE BLACK #8 AWG (PN390019).
△ - INDICATES WIRE TO BE BLACK #4 AWG (PN390021).

4. DASH LINES INDICATE CUSTOMER CONNECTIONS.
3.
2.
1.

UNLESS OTHERWISE SPECIFIED THE ABOVE NOTES APPLY

K775D16930

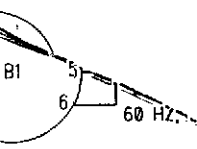

ECN NO.	REV	DESCRIPTION	REVISIONS	DATE	APPROVED
CC068	F	REVISED & REDRAWN PER ECN, ADDED WIRING INFO. BLOWER CIRCUIT WAS 480V	FACKELMANN	2/28/80	J HUDSON

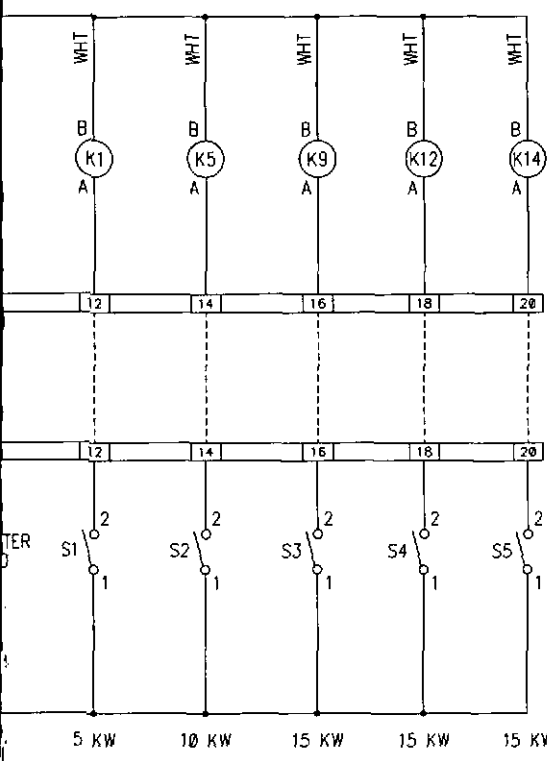
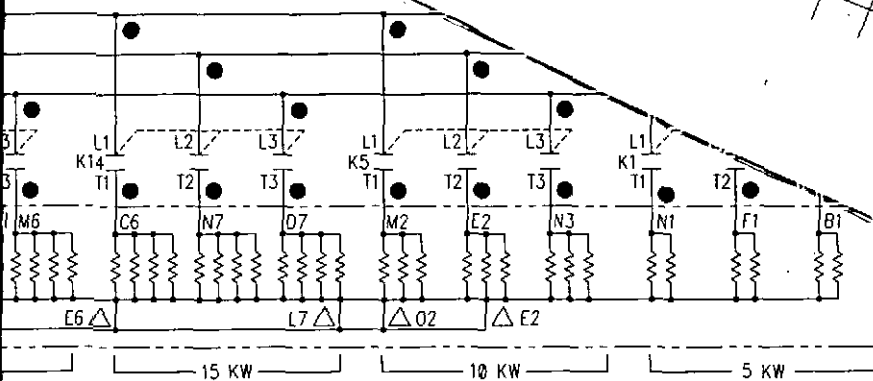

THIS DOCUMENT CONTAINS PROPRIETARY INFORMATION OF AVTRON MFG., INC AND MAY NOT BE DISCLOSED TO OTHERS OR USED FOR MANUFACTURING PURPOSES WITHOUT THE WRITTEN CONSENT OF AVTRON MFG.

UNLESS OTHERWISE SPECIFIED DIMENSIONS ARE IN INCHES		DRAWN	DATE		7900 E.PLEASANT VALLEY ROAD INDEPENDENCE, OH 44131-5579
TOLERANCES: ANGLES ± 1' DECIMALS .XX ± .03 .XXX ± .015		CHECKED	BW 12-7-84		
FINISH		ENG APVD	D.McRAE 12-18-84	SCHEMATIC, LOAD BANK 60KW, 208V, 3 PHASE	
PAINT PER PS		APVD FROD			
K775D16930	K775D16930			SIZE	CAGE NO.
NEXT ASSY	USED ON			D	01014
APPLICATION				DWG. NO.	017554
OTHER				SCALE	1/1
				MODEL	K775
				SHEET 1 OF 1	

IMF
 PSF

 REV F

PART NO	RELAY BE WITH
D16953	K1
D16952	K1, K5
D16951	K1, K5, K
D16950	K1, K5, K9, K12
D16949	K1, K5, K9, K12

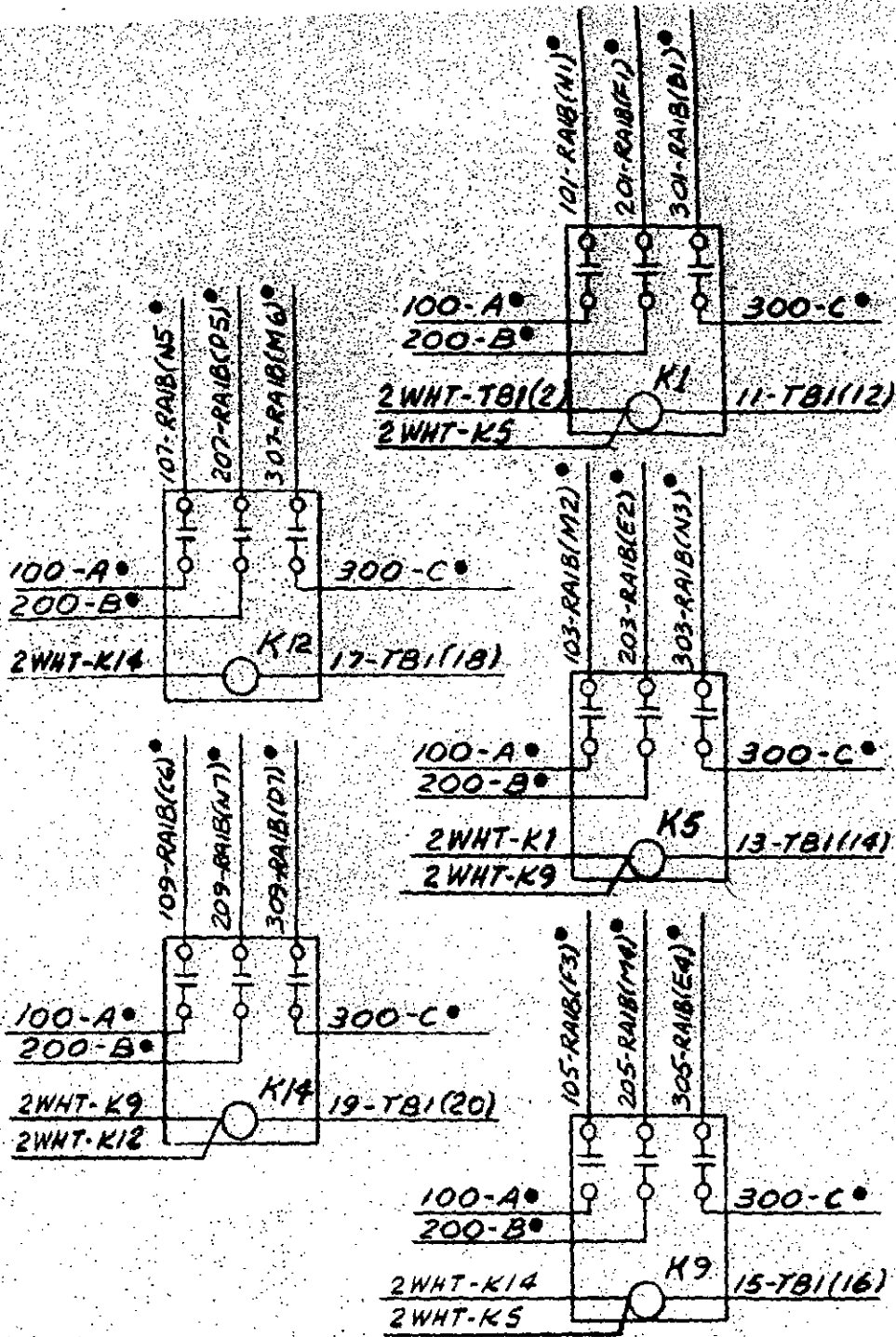

TBL

2WHT-K1	1
	2
	3
	4
	5
	6
	7
	8
	9
	10
	11
11-K1	12
	13
13-K5	14
	15
15-K9	16
	17
17-K12	18
	19
19-K14	20

5- ALL WIRE TO BE BLACK UNLESS OTHERWISE NOTED.

- WIRE SIZE:
 ● = # 8 AWG (390019)
 △ = # 4 AWG (390021)
 ALL OTHERS #16 AWG (390008)

YENDOR ITEM - SEE SOURCE OR SPEC CONTROL DRAWING.

REMOVE BURRS AND SHARP EDGES.

WEIGHT:

IF OTHERWISE SPECIFIED THE ABOVE NOTES APPLY.

401-RA1A[△], 401-RA1A[△]
 (N) 401-RA1A[△], 401-RA1A[△], 401-RA1A[△]
 401-RA1A[△], 401-RA1A[△]
 (DO NOT BUNDLE)

Warranty

Warranty and Duration

For a period of one year after installation, or fifteen (15) months from date of shipment from our plant, whichever is shorter, Avtron warrants the equipment, except as hereinafter provided, to be free from harmful defects in material and workmanship. Notwithstanding any other term or provision in this Warranty, the warranty provided herein shall terminate unless buyer notifies Avtron, in writing, of a breach hereof within the warranty period; any claims not made within such period are waived by Buyer. The warranty provided herein applies only if Buyer complies with all the other terms and provisions of this Warranty.

Uses of Equipment

The warranty provided herein applies only if the equipment has been used in a normal and proper manner under recommended conditions. Notwithstanding any advice or assistance given to the Buyer by Avtron or its suppliers concerning the equipment or its use, Avtron makes no express or implied warranties or representations, except as herein expressly provided, with respect to the equipment or its use, and Avtron shall not be liable in contract, warranty or tort (including, without limitation, for negligence or strict liability) as a result of such advice or assistance. In addition, unless otherwise agreed in writing signed by a duly authorized representative of Avtron, no equipment covered by this warranty is intended to be used in connection with any nuclear facility or activity, and if so used, Avtron disclaims any and all liability for any damage resulting therefrom.

Notification of Breach

When claiming a breach of this Warranty, Buyer must promptly (within 10 days from the date of the discovery of the defect) notify Avtron in writing.

Equipment Disposition

Upon notification of a claimed breach of this Warranty, Avtron, at its discretion, will either authorize the return of the defective equipment or part thereof (transportation costs to be prepaid by Buyer) or provide a suitable replacement or authorize the Buyer in writing to effect repairs at Avtron's expense. In the event that the equipment returned as authorized is found to be defective and Avtron elects to repair or replace said equipment, Avtron will pay the transportation costs associated with the return of said equipment to Buyer. Avtron shall not however be liable for any customs, tariffs, duties or taxes incurred in shipping equipment pursuant to this Warranty. These shall be the responsibility of the Buyer.

Option of Avtron to Repair or Replace Equipment or to Issue Credit

Avtron's sole obligation under this Warranty shall be, at the option of Avtron, to replace or repair any defective equipment or part thereof or to issue a credit with respect to the defective equipment equal to the purchase price thereof less depreciation.

Equipment Excluded From Warranty

The warranty provided herein specifically excludes equipment and components that Avtron purchases and resells as part of a system, product or spare part order. The warranties provided to Avtron by the manufacturers of the foregoing equipment and components will, to the extent possible, be passed on to the Buyer. Copies of such warranties, if on file at Avtron, will be made available for inspection upon the request of Buyer. Equipment such as, but not limited to, computers, CRTs, operator interface modules, monitors, etc., normally have a short warranty period and should be covered by a continuous service contract generally available from the original manufacturer at a reasonable cost. Consumable items including, but not limited to, lamps, filters, fuses and motor brushes are excluded from all warranties. Other items or components may be excluded from this warranty if so noted in the governing purchase order or contract.

Resale or Lease of Equipment

In the event that the Buyer resells or leases equipment purchased from Avtron, the Buyer shall obtain the signed written agreement of the purchaser or lessee thereof that Avtron's only liability with respect to said equipment is as set forth in this Warranty. In the event that the Buyer fails to obtain such a signed written agreement, the Buyer agrees to indemnify Avtron against any claims, demands, judgments, suits, costs, liabilities and expenses (including reasonable attorney's fees) incurred by Avtron as a result of such failure.

Unauthorized Repairs

Unless otherwise agreed in writing signed by a duly authorized representative of Avtron, if the Buyer has repairs or modifications made to equipment covered by this Warranty by a person other than an authorized Avtron service representative, Avtron shall not be liable for any expenses incurred in connection therewith and the warranty provided herein shall automatically be terminated.

Governing Law; Saving Clause

This Warranty is part of the terms and conditions of the sale of the equipment covered hereunder and shall be governed by and enforced in accordance with the laws of the State of Ohio. Any provision hereof which is prohibited or unenforceable in any jurisdiction shall, as to such jurisdiction, be ineffective to the extent of such prohibition or unenforceability without invalidating the remaining provisions hereof or affecting the validity or enforceability of such provision in any other jurisdiction.

Limitation of Liability

IN NO EVENT SHALL AVTRON BE LIABLE IN CONTRACT, IN TORT OR OTHERWISE FOR SPECIAL, INCIDENTAL, CONSEQUENTIAL OR PUNITIVE DAMAGES (INCLUDING, BUT NOT LIMITED TO, LOSS OF PROFITS OR REVENUES, LOSS OF USE OF THE EQUIPMENT OR ANY DAMAGE TO ASSOCIATED EQUIPMENT, DAMAGE OR INJURY TO PERSONS OR PROPERTY, COST OF CAPITAL, COST OF SUBSTITUTE OR TEMPORARY EQUIPMENT, DOWNTIME OR CLAIMS OF CUSTOMERS) ARISING OUT OF OR AS A RESULT OF BREACH OF WARRANTY, DEFECT IN MATERIAL OR WORKMANSHIP OR ANY OTHER OBLIGATION OF AVTRON HEREUNDER.

Disclaimer of All Other Warranties

THIS WARRANTY COMPRISES AVTRON'S SOLE AND ENTIRE WARRANTY OBLIGATION TO BUYER, ITS CUSTOMERS AND ASSIGNS IN CONNECTION WITH EQUIPMENT SOLD, ASSIGNED, LEASED OR OTHERWISE DEALT WITH BY AVTRON. ALL OTHER WARRANTIES, EXPRESS OR IMPLIED, INCLUDING, BUT NOT LIMITED TO, WARRANTIES OF MERCHANTABILITY AND FITNESS, ARE EXPRESSLY EXCLUDED.

