

INSTRUCTION MANUAL

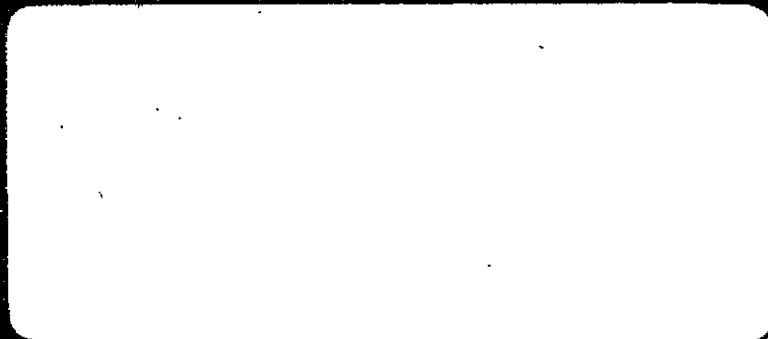

Specialists in the Following Services for Industry

DIGITAL MEASUREMENT AND CONTROL SYSTEMS

TEST EQUIPMENT FOR AIRCRAFT ELECTRICAL COMPONENTS

RESISTIVE AND REACTIVE LOAD BANKS

ROTARY PULSE GENERATORS

AUTOMATIC WINDING TEST SYSTEMS



All Sales and Service for
Aircraft Test Equipment:
7900 E. Pleasant Valley Rd.
Independence, Ohio 44131-5529
TELEPHONE (216) 642-1230
FACSIMILE (216) 642-6037

Service for All
Other Products:
10409 Meech Ave.
Cleveland, Ohio 44105-4183
TELEPHONE (216) 641-8310
FACSIMILE (216) 341-8803

**AVTRON MODEL K841B
LOAD BANK SYSTEM
(Outdoor, Reactive)
Part Number K841BD23154**

**AVTRON MODEL K841B
LOAD BANK SYSTEM
(Outdoor, Reactive)
Part Numbers K841BD23154
thru K841BD23165**

© 1994 Avtron Manufacturing, Inc.
Cleveland, Ohio

March 13, 1992
Rev. Nov. 25, 1997

PROPRIETARY NOTE

This document contains information PROPRIETARY to Avtron Manufacturing, Inc., is furnished solely to provide information sufficient for instruction, operation, maintenance, evaluation, and testing of the equipment herein disclosed, is not to be used for manufacturing or procurement and is not to be disclosed to anyone other than persons in the Division, or the Company, or the Government, as the case may be, responsible for action relating to this document without the express written permission of Avtron Manufacturing, Inc.

WARRANTY

The last page of this document contains an express limited warranty. The provisions of this warranty cover any and all rights extended to holders of Avtron equipment.

AVTRON MANUFACTURING, INC.
Cleveland, Ohio

AVTRON MODEL K841B
LOAD BANK SYSTEM
(Outdoor, Reactive)
Part Numbers K841BD23154 thru K841BD23165

TABLE OF CONTENTS

<u>Section</u>		<u>Page</u>
I	SAFETY CONSIDERATIONS.	1-1
II	DESCRIPTION.	2-1
III	INSTALLATION	3-1
IV	OPERATION.	4-1
V	MAINTENANCE.	5-1
VI	REPLACEMENT PARTS LIST	6-1
VII	OPTIONS	7-1

APPENDIX - Avtron Load Bank Troubleshooting Guide

SUPPLEMENTAL DATA

KW-KVAR-KVA Power Factor Chart

DRAWINGS

Load Bank	Schematic	Outline	KVAR	Res	Volts
K841BD23154	D23166	SB2159	750	37.50	240/480
K841BD23155	D23167	SB2159	750	3.75	240/480
K841BD23156	D23168	SB2159	603	*	240/480
K841BD23157	D23169	SB2159	600	3.75	240/480
K841BD23158	D26937	SB2159	600	37.50	240/480
K841BD23160	D23171	SB2159	450	37.50	240/480

*This unit is equipped with a continuously adjustable control to provide infinite load resolution.

TABLE OF CONTENTS (Cont.)

OPTIONS - Refer to Section VII (OPTIONS FOR K841B) of this manual. The following drawings apply to the various options. Only drawings for the options provided have been included in this manual. Not all options can be installed in the same unit. Installed options are marked on the identification tag.

Drawings:

- *A23476 Option 1, 480/120 Volt Control Transformer
- *A23477 Option 2, 240/120 Volt Control Transformer
- *B28144 Option 4, Underfrequency Protection
- *B28145 Option 5, Overvoltage Protection

*These drawings also contain electrical schematic information.

AVTRON MODEL K841B
LOAD BANK SYSTEM
(Outdoor, Reactive)
Part Number K841BD23154
thru K841BD23165

SECTION I

SAFETY CONSIDERATIONS

Throughout this manual, you will find **WARNING** and **CAUTION** statements. Personal injury to an operator using or repairing the equipment may occur if the **WARNING** statements are ignored. Damage to the equipment and potentially hazardous conditions for personnel may occur if the **CAUTION** statements are ignored.

Each Avtron unit is safety checked for opens and shorts, and the insulation is high potential tested to insure safe conditions. All fuses, safety interlocks, and related safety equipment have been tested as part of the testing procedure of each unit.

As part of your safety program, an initial inspection should be conducted upon receiving the unit(s). Periodic preventive maintenance and safety inspections should also be conducted to insure the reliability and safety that has been built into your Avtron equipment.

The Model K841B Load Bank is an industrial test unit designed to be used safely. However, because of the nature of the Load Bank function--the dissipation of electrical energy--there is inherent danger to the operators and to the equipment. Safety precautions are listed below and should be followed to ensure safe and correct usage of the Load Bank.

1. Read the manual before operating the Load Bank.
2. Using an approved ground conductor, wire from the Load Bank ground lug to the generator frame. Using an approved ground conductor, wire from the generator frame to a good earth ground.
3. Do not bypass the OVER TEMPERATURE safety switch to prevent nuisance tripping. The switch will remove load if insufficient cooling air is reaching the load elements. Multiple over temperature safety switches are used in the K841B. Each three phase iron core reactor has an over temperature switch located in each coil

- winding. These switches will remove individual reactors if an over temperature fault occurs on a single reactor. An ambient over temperature switch is also used to drop all load.
4. Replace any burned out bulbs on the Control Panel. Each lamp is an indication that a system is active or has failed and is important to the operation of the facility and safety of the operator.
 5. Maintenance personnel must always exercise caution when the access panels are removed. Personal injury from electrical shock or from the moving blower blade may result if all sources of power are not disconnected before servicing. This is especially important since the blower motor has an automatic reset temperature switch that can restart the blower. Maintenance work must be done only by qualified personnel.
 6. Allow cool air to pass into the unit to cool the elements. Do not allow the unit to be placed where hot exhaust air can recirculate back through the unit causing a constant rise in cooling air temperature.
 7. After running a load test, residual heat may be removed from the Load Bank by allowing the blower to operate for a few minutes after loads are removed. This procedure is not required for Load Bank integrity, but it may guard operating personnel from possible burn injuries.
 8. Do not allow objects to enter or block the air intake or exhaust of the Load Bank. Air intake on the K841B is through the screened floor, exhaust is through the top of the unit. A blockage would cause Load Bank overheating. If an object enters the screens, it will cause damage to the reactive elements, possibly shorting them and causing shock and/or fire hazards. The area around the K841B base must be kept clear for cooling air flow.
 9. Operators must not operate the Load Bank with the access panels or screens removed. To do so would expose the operator and other persons to possible personal injury from electrical shock or from the moving fan blade.
 10. Emergency Shutdown Procedure:
 - A. In an emergency, shut down the MASTER LOAD switch, then the generator. The MASTER LOAD switch will allow disconnection of all load steps and still

Safety Considerations

Avtron Model K841B
Load Bank System
Part Number K841BD23154
thru K841BD23165

- allow for the fan motor to run, cooling any heated elements.
- B. The POWER ON/OFF switch will disconnect both load steps and the fan motor. The Generator Emergency "OFF" switch should be located near the load system.
11. An approved electrical fire extinguisher should be on hand at all times.
 12. It is the responsibility of the customer to take diligent care in installing the Load Bank. The National Electrical Code (NEC), sound local electrical and safety codes, and the Occupational Safety and Health Act (OSHA) should be followed when installing the equipment to reduce hazards to persons and property.
 13. Read and heed all **WARNING** and **CAUTION** statements in the manual.

SECTION II

DESCRIPTION

A typical Model K841B Load Bank System consists of the following separate pieces of equipment:

- 1) One K841B Load Bank
- 2) One control panel for remote 19" rack mount
- 3) A NEMA enclosure for the control panel is available as an option.

The system is capable of providing the reactive load at voltage, frequency, and resolution as charted on the Table of Contents.

The K841B Load Bank is constructed from formed heavy-gauge sheet steel, making a rigid structure. Channels are provided in the base structure to facilitate handling by a forklift truck. It is strongly recommended that the forklift channels be used for handling when possible. If necessary, the channels in the outside corners of the base structure may be used for lifting.

The K841B unit contains a cooling fan located on top of the air channel which provides the necessary cooling air for the load reactors. The cooling fan operates from a 120V control power. The blower motor is protected by an in-line overcurrent fuse.

C A U T I O N

This Load Bank should never be used without the fan blower motor operating. Inadequate cooling air flow will cause reactor overheating and a definite fire hazard.

A temperature switch is provided to monitor the exhaust air temperature. This temperature switch is electrically interlocked with the load application controls to prevent load application if the blower is not working properly (OVER TEMPERATURE FAILURE light comes on). The temperature switch contains hysteresis to avoid temperature cycling. The temperature switch will open at $210^{\circ} \pm 5^{\circ}\text{F}$ and reset automatically at $160^{\circ} \pm 8^{\circ}\text{F}$.

Description

The Load Bank control panel is sized for 19" rack mount. The panel is equipped with a MAIN POWER ON-OFF switch with a MAIN POWER-ON light, OVER TEMPERATURE FAILURE light, a MASTER LOAD ON-OFF switch, a VOLTAGE SELECTOR 240 or 480 switch, and load toggle switches. The control panel also contains a fuse for the control circuit.

W A R N I N G

Care must be exercised that all power to both Load Banks and control circuits is disconnected before entering the unit. All safety controls should be linked to the control panel so a failure can be noted at the control unit.

SECTION III

INSTALLATION

BEFORE INSTALLATION

Inspect the Load Bank for obvious damage such as broken wires, broken or dented panels, or any other component breakage that may have occurred in shipment.

The Load Bank should be positioned so that there is a minimum of 12 inches of clearance around the perimeter of the base.

Heat dissipation is in the range of 17,000 to 35,000 BTU/hour, depending upon the size of the load. Room size and ventilation should be considered during installation. If the room is small, a 10,000 CFM rate of ventilation will limit the temperature rise caused by a 375 KVAR unit to approximately 25°C (45°F). The K841B Load Bank contains a cooling fan and an air temperature detection circuit. (See the Schematic/Interconnection diagram.) Both operate from 120 volts, 60 Hz power.

The air temperature detection circuit is interlocked with the control circuit to prevent application of load power if inadequate cooling conditions exist.

C A U T I O N

This Load Bank should never be used without the cooling fan operating. Operation of this unit without proper installation or without proper airflow protection VOIDS the Avtron Warranty.

AIRFLOW CONSIDERATIONS

Even with an ample supply of cooling air, the Load Bank may overheat if it is not properly installed. Recirculating airflow

must be avoided. If the hot, exhausted air is permitted to recirculate through the Load Bank, it will reach such a high temperature and low density that it will no longer cool the reactors. A Load Bank should not be installed so close to any surface as to reflect the exhausted air back to the air intake. When two or more Load Banks are being used, care must be taken in positioning the Load Banks so that the exhausted air of one unit does not feed the air intake of another.

W A R N I N G

It is vitally important to install the Load Bank properly. Installation errors may result in a catastrophic failure. The TEMPERATURE switch, a protective device in the Load Bank, will guard against some of these problems. If protective circuitry prevents application of the load, determine the source of the problem. DO NOT DISABLE THE TEMPERATURE SWITCH. This will cause a safety hazard and will void our warranty. The following installation instructions are critical to the safe operation of the Load Bank. Refer to the Safety Considerations section of this manual.

CONTROL CONNECTIONS

Typically the Control Panel requires a 120 volt single phase, 60 Hz, 20 amp source. Some units use built-in control transformers and operate at other voltages. See the Schematic/Interconnection Diagram for specific wiring information for your application.

GROUNDING

A permanent ground conductor must be connected to the Load Bank enclosure by an individual ground wire to prevent a potential above ground on the enclosure. There is a ground stud in the Load Bank for this connection. This ground conductor should be run with the load power conductors to provide the lowest impedance fault path.

Installation

The ground stud must be connected to both the generator frame and to a good earth ground.

LOAD CONNECTIONS

Load connections to the Load Bank are made at the phase bus bars marked A, B, and C, which are located inside the load end of the unit. See outline drawing for the Recommended Conduit Entrance area, and wire as indicated in the Schematic/Interconnection Diagram.

WIRING INFORMATION

To establish the correct cable size for the ground and load connections, use the following equation to determine the maximum line current per phase:

$$\text{Amps/Phase Max.} = \frac{\sqrt{(KW^2 + KVAR^2)} \times 577}{V \text{ (line-to-line)}}$$

Use this value to select the correct wire size as defined by the National Electrical Code.

Cable size selection for control power, load, and ground cables must take into account the length of the cable, the type of cable, bundling, temperature derating, etc. Refer to the National Electrical Code for complete cable information. Cable specifications should be determined by qualified personnel.

SECTION IV

OPERATION

DESCRIPTION OF CONTROLS

1. POWER ON switch is used to apply power to the control circuit and activates the Load Bank blowers.
2. MAIN POWER ON light indicates that control power is on or off.
3. BLOWER ON light indicates power is applied to the blower motor.
4. OVER TEMPERATURE FAILURE light. When lit, the lamp indicates an excessive temperature rise within the cabinet. The temperature switch will open at $210 \pm 8^{\circ}\text{F}$ and reset automatically at $160 \pm 5^{\circ}\text{F}$.
5. MASTER LOAD. The MASTER LOAD switch applies and removes power to all of the load step switches.
6. LOAD STEP switches. The load rating is marked for each actuating switch. A load step may be turned ON or OFF before or during a test, but will load the unit only when the MASTER LOAD switch is on.
7. VOLTAGE SELECTOR switch allows for selecting the voltage necessary for the unit under test.

LOAD BANK OPERATION

1. Place all switches on the control panel to the OFF position.
2. Connect the generator leads and ground cable to the Load Bank as described in the Installation section.
3. Place the VOLTAGE SELECTOR switch to the appropriate voltage required to test the generator.

C A U T I O N

The generator output rating must never exceed the rated voltage of the Load Bank as this will cause the Load Bank to overheat and will cause catastrophic failure in the Load Bank.

Do not apply DC voltages as the contactors do not have arc blowout magnets. Also, the reactive load sections will react as low impedance short circuit paths, resulting in a definite fire hazard.

DO make sure that the VOLTS SELECTOR switch is in the proper position before applying load.

4. Place the MAIN POWER switch to the ON position. The MAIN POWER ON and BLOWER ON lights will be energized, indicating power is present.

C A U T I O N

Shut down the Load Bank if an OVER TEMPERATURE FAILURE occurs. Troubleshooting and repair procedures must be performed to correct the cause of the problem before attempting to operate the Load Bank. Refer to the Safety Considerations, Troubleshooting (see APPENDIX), and Maintenance sections in this manual.

5. With the MASTER LOAD switch in the OFF position, start the generator under test.
6. The desired load is preselected using any one or a combination of toggle switches.

Operation

7. By placing the MASTER LOAD switch to the ON position, the preselected load will be applied to the power source.
8. Any load switch can be added or removed as required with the MASTER LOAD switch closed (ON).
9. To remove the load, move the MASTER LOAD switch to the OFF position.
10. Shutdown procedure:
 - a) Turn the MASTER LOAD switch and the load step toggle switches to the OFF position. Residual heat may be removed from the Load Bank by allowing the blower to run for several minutes after the loads are turned to their OFF position. Although not required for maintaining Load Bank integrity, this may guard operating personnel from possible burn injuries.
 - b) Turn the POWER switch to the OFF position.
 - c) Turn all safety switches to which the Load Bank may be connected to the OFF position. These should include (for operator and personnel safety):
 - 1) Control circuit safety switch.
 - 2) Load power circuit breaker.

W A R N I N G

DO NOT allow objects to enter or block the inlet area of the base or exhaust screen.

C A U T I O N

Never exceed the rated voltage as this will cause the Load Bank to overheat.

If lower frequencies are applied, load terminal voltages must be reduced by a proportional amount.

NOTE

Lower frequencies may also be applied to the load circuit. The applied KVAR with a reduced frequency is computed with the following formula:

$$\text{KVAR}_{\text{Applied}} = \text{KVAR}_{\text{Rated}} \times \frac{\text{Rated Frequency}}{\text{Applied Frequency}} \times \frac{(\text{Voltage Applied})^2}{(\text{Voltage Rated})^2}$$



ESD PRECAUTIONARY GUIDELINES

C A U T I O N

Certain circuit card assemblies and their components, typically integrated circuits, may be damaged by seemingly undetectable electrostatic discharge (ESD). Care must be exercised during handling/repair of these items. Use electrostatic discharge precautionary procedures.

The following guidelines are not necessarily all inclusive but rather serve as reminders for good shop practices for the handling/repair of ESD sensitive circuit card assemblies and devices.

- Store ESD sensitive items in their original containers. These items are often marked with the symbol shown at the top of this page.
- Put on a grounded wrist strap before handling any ESD sensitive item.
- Clear work area of Styrofoam[®]*, plastic, and vinyl items such as coffee cups.
- Handle ESD items by the body, never the open edge connectors.
- Never slide ESD sensitive items over any surface.
- Transport ESD sensitive items in a static shielding container to a static-free work station.
- If a static-free work station is not available, ground the transport container before removing or inserting an ESD item.
- Electric tools used during repair should be grounded. For example, use only anti-static type solder suckers and grounded tip soldering irons. Discharge non-electric tools before use.
- Pack ESD items in static shielding containers before shipping them to Avtron for repair.

*Styrofoam[®] is a registered trademark of Dow Chemical.

SECTION V

MAINTENANCE

To provide long equipment life and to reduce the chance of electric shock, fires, and personal injury, good maintenance procedures must be used. Before servicing, review the Safety Considerations section of this manual.

The following are examples of maintenance procedures and a suggested maintenance schedule. These examples are not intended to be all-inclusive but must be accomplished to maintain the equipment in a good, safe condition. All maintenance work must be done by qualified personnel only.

W A R N I N G

Personal injury from electrical shock or from the moving fan blade may result if ALL sources of power are not disconnected. Refer to the Safety Considerations section of this manual. Eye protection should be worn when cleaning the unit with compressed air.

DAILY

1. Remove any restriction to airflow through the Load Bank.
2. Check the screens to make sure that no objects have blocked or entered the openings.
3. Assure that there is no recirculation of the exhaust air through the Load Bank.

Maintenance

THREE MONTHS

1. Remove access panels and screens and inspect for loose hardware or loose connections. Tighten where required.
2. Inspect all connections for oxidation or corrosion. Clean the connection or replace the hardware where required.
3. Inspect all magnetic contactors to make sure that the contacts are not severely pitted or corroded. The contacts must move freely and be properly seated.
4. Clean all dirt and debris out of the Load Bank. This can be accomplished by blowing the inside of the unit with clean, dry compressed air (not to exceed 40 PSI). Eye protection should be worn when cleaning the Load Bank with compressed air.
5. Inspect all the wiring for any sign of insulation failure.
6. Replace all access panels and screens. Tighten all the fastening hardware securely.
7. Check the indicator lamps on the control panel.

REPLACEMENT PARTS LIST

SCHEMATIC REFERENCE	DESCRIPTION	MANUFACTURER and PART NO.	AVTRON P/N	QTY/ UNIT	
K41,43,45, 47,49,51, 53,55,57	AVTRON MODEL K841B		K841B	1	
	LOAD BANK (REACTIVE)		D23154		
	.Schematic/Intcon. Diag.		D23166	REF	
	.Relay Assy., Pilot		D23225	1	
	..Relay	Potter & Brumfield KUP14A15	351060	9	
	..Socket, Relay	Potter & Brumfield 27E893	358280	9	
	..Retainer, Hold Down Spring (used with 358280 Relay Socket and KUP Relay)	Potter & Brumfield 20C318	467550	9	
	TB11,12	..Terminal Board	Cinch Mfg. 20-140	364103	2
		..Insulation, Marker Strip	Cinch Mfg. MS-20-141	450028	2
	K240,480	..Relay		B17839	2
L41,42	.Reactor 187.5 KVAR		C21009	2	
L39,40	.Reactor, 75 KVAR		C21024	2	
L35-38	.Reactor, 37.5 KVAR		C21039	4	
L50-55	.Reactor, 6.25 KVAR		650054	6	
L30-32	.Reactor, 6.25 KVAR		650271	3	
L24-29	.Reactor, 2.5 KVAR		650268	6	
L21-23	.Reactor, 1.25 KVAR		650267	3	
R26-29	.Resistor, Adjustable, 50 Ohms		B22256	4	
K37,38	.Relay	ABB Controls EH700C-111	350509	2	
K35,36	.Relay	ABB Controls EH270C-111	351997	2	
C1	.Capacitor, 40 μ F (Used on units S/Ns 37 and below only)	EBM Ind. CAP40UF/90330	281078	1	
K31-34	.Relay	ABB Controls EH-110C-111	351896	4	
K28-30	.Relay: 3 Pole N.O. 1000V, Open Type, Std. Lugs, 120 VAC Coil, 3 Aux Contact Block for 3 N.O. and 3 N.C. Aux Contacts, Rated 75 Amps at 0.05 PF	ABB Controls B63C-1-02 Per Descr.	351872	3	
K21-27	.Relay		B14711	7	
XF39-50	.Fuseholder	Bussmann 1B0078	324660	4	
XF21-38	.Fuseholder	Bussmann T60030-3CR	324977	6	
F69-74	.Fuse, 600A, 600V	Bussmann JJS-600	324739	6	
F63-68	.Fuse, 250A, 600V	Bussmann JJS-250	324737	6	

Avtron Model K841B
Load Bank (Reactive)
Part Number K841BD23154

SCHEMATIC REFERENCE	DESCRIPTION	MANUFACTURER and PART NO.	AVTRON P/N	QTY/UNIT
F51-62	.Fuse, 125A, 600V	Bussmann JJS-125	324736	12
F40,42,44-50	.Fuse, 60A, 600V	Littelfuse JLLS-60	324345	9
F39,41,43	.Fuse, 35A, 600V	Littelfuse JLLS-35	324484	3
F28,30,32, 34,36,38	.Fuse, 25A, 600V	Littelfuse JLLS-25	324483	6
F22,24,26, 27,29,31, 33,35,37	.Fuse, 15A, 600V	Littelfuse JLLS-15	324481	9
F21,23,25	.Fuse, 10A, 600V	Littelfuse JLLS-10	324480	3
	.Power Distribution Block	USD Products 16530-3	364921	1
TB1,10,13,14	.Terminal Board	Cinch Mfg. 20-141	364103	4
	.Insulation, Marker Strip (used with 364103)	Cinch Mfg. MS-20-141	450028	4
TS1	.Switch, Thermal: 3/4" Bimetal Disc, 240V, 10 Amp SPST N.O., To Close at 210°F \pm 6°F and Open at 160°F \pm 10°F, Bracket for Airstream Mtg. Crimped at 90°F \pm 15° from Terminals	Therm-o-disc 60T Per Descr.	363010	1
B1	.Ventilator (used on units S/Ns 38 and above)	McMaster-Carr 1943K13	322203	1
	.Blower (used on units S/N 37 and below)	EBM Industries RH45M-6-206523	322152	1
	.Control Panel		C22555	1
DS1-3	..Lamp	General Electric 636/115-125V	333011	3
XDS1,3	..Light, Indicator	Dialight Corp. 502-3214-0113-302	329138	2
XDS2	..Light, Indicator	Dialight Corp. 502-3214-0111-302	329136	1
F1	..Fuse, 12A	Bussmann LP-CC-12	324764	1
	..Fuseholder	Bussmann HPS-RR	324985	1
TB21	..Terminal Block	Cinch Mfg. 20-141	364103	1
	..Insulator	TRW MS-20-141	450028	1
K24	..Relay	Potter & Brumfield KUP14A55	351170	1
S1,2,4-13	..Switch, Toggle	Carlingswitch 2GK50-73	360589	12
S3	..Switch, Toggle	Cutler-Hammer 7992K10	360747	1
XF11,12	.Fuseholder	Bussmann R60030-2PR	324671	1
F11,12	.Fuse	Bussmann FR-R-12	324468	2

SECTION VII

K841B OPTION LIST

These options are available for Avtron Model K841B Load Banks. Not all options can be installed in the same unit. Installed options are marked on the identification tag.

<u>Option Drawing No.</u>	<u>Option</u>	<u>Description</u>
A23476	1	Installation of a 480 volt primary, 120 volt secondary, 1.5 KVA control transformer
A23477	2	Installation of a 240 volt primary, 120 volt secondary, 1.0 KVA control transformer
B28144	4	Underfrequency Protection
B28145	5	Overvoltage Protection
A22553	6	Installation of Option 6 for K841B

REPLACEMENT PARTS LIST

SCHEMATIC REFERENCE	DESCRIPTION	MANUFACTURER and PART NO.	AVTRON P/N	QTY/ UNIT
	<u>OPTION #1: INSTALLATION OF CONTROL</u>		A23476	
T1	TRANSFORMER, 480:120V			
XF2,3	.TRANSFORMER, CONTROL; 2000 VA, 240/480V PRI, 120V SEC	GENERAL ELECTRIC Y2000	371119	1
F2,3	.FUSEHOLDER, 2 POLE, 30A, 600V, UL CLASS R, SCREW TERMINALS	BUSSMANN R60030-2PR	324671	1
	.FUSE, 6 AMP, 600V, TIME DELAY, CLASS RK-5	BUSSMANN FRS-R-6	324393	2
	<u>OPTION #2: INSTALLATION OF DUAL</u>		A23477	
	VOLTAGE TRANSFORMER, 240/480:120V			
T1	.TRANSFORMER, CONTROL; 2000 VA, 240/480V PRI, 120V SEC	HEVI-DUTY ELECTRIC Y2000	371119	1
TB101	.TERMINAL BOARD, BARRIER TYPE	VERNITRON 78020	364103	1
XTB101	.MARKERSTRIP	KULKA ELECTRIC MS601-20	450028	1
FS101	.FANNING STRIP .44 CENTERS 8 TERMINALS	KULKA ELECTRIC 651-8-L	365080	1
XF2,3,5,6	.FUSEHOLDER, 2 POLE, 30A, 600V, UL CLASS R, SCREW TERMINALS	BUSSMANN R60030-2PR	324671	2
F2,3	.FUSE, 6 AMP, 600V, TIME DELAY, CLASS RK-5	BUSSMANN FRS-R-6	324393	2
F5,6	.FUSE, CARTRIDGE, 12 AMP, 600V, TIME DELAY, CLASS RK-5	BUSSMANN FRS-R-12	324468	2
T3	.TRANSF, CONT; 50 VA, 440/460/480V PRI, 220/230/240V SEC, 50/60 HZ	SQUARE D 9070-T50D12	370528	1
K241	.RELAY, VOLTAGE SENSING; 180-276V PICKUP	MAGNECRAFT ELECTRIC W236ACX-2	350740	1
XK241	.SOCKET, RELAY	TELEMECANIQUE H50SL711	358215	1
XF8	.FUSEKIT, TRANSFORMER SECONDARY	SQUARE D 9070-AP-3	324964	1
F8	.FUSE CARTRIDGE 0.5A, 250V	LITTELFUSE 312-1/2	324005	1
K242	.RELAY, 3P, 25A, 110/120V, 50/60 HZ COIL PER AVTRON DWG.		B14795	1
	<u>OPTION #4: UNDERFREQUENCY PROTEC-</u>		B28144	
	<u>TION</u>			
K101	.RELAY, FREQUENCY SENSOR INPUT 240V OR 480 VAC, OVER TRIP 50-70 HZ. UNDER TRIP 50-70 HZ. TRIP DIFFERENTIAL 0.3 - 3 HZ	PC&S STANHOPE M200-F1C-VE-PA	350565	1

SCHEMATIC REFERENCE	DESCRIPTION	MANUFACTURER and PART NO.	AVTRON P/N	QTY/ UNIT
K102	<p>OPTION #5: OVERVOLTAGE PROTECTION .RELAY, VOLTAGE SENSE</p>	<p>SYRELEC MODEL C1U P/N 84-893-106</p>	<p>B28145 351653</p>	<p>1</p>
R102	<p>.RESISTOR, 100K, 1/2 W, 10%</p>		<p>110048</p>	<p>1</p>

APPENDIX

LOAD BANK TROUBLESHOOTING GUIDE

NOTE

Servicing should always be done only by trained, qualified service technicians.

W A R N I N G

Be sure that all sources of power to the Load Bank are disconnected before servicing.

PROBLEM	POSSIBLE CAUSES/REMEDIES
1. Load Bank main power fails to come on.	<ul style="list-style-type: none"> a. Main switch or circuit breaker is not closed. b. Unit is not connected according to the Schematic/Interconnection Diagram. c. Terminals were damaged during shipment. d. Fuses are blown. (Check and replace as required.)* e. Fuse is blown in Load Bank control circuit. (Check and replace as required.)* f. Dirty or loose connection at Main Power Switch.
2. Blower motor does not operate.	<ul style="list-style-type: none"> a. Main switch or circuit breaker is not closed. b. Power is not connected to Load Bank blower circuit. c. External power source is inadequate. d. Motor fuses are blown. (Check and replace as required.)*

* When checking fuses for continuity, be sure to remove all fuses from clips (in fuseblock or Disconnect Switch). Test each fuse individually, out of circuit. (If tested in circuit, there is the possibility of feedback which causes false readings. A blown fuse may still check out OK.)

PROBLEM	POSSIBLE CAUSES/REMEDIES
2. Blower motor does not operate. (Cont.)	<ul style="list-style-type: none"> e. Motor overload is tripped. f. Motor start is malfunctioning. g. Main Power Switch is inoperative. h. Connections are broken or loose. i. Motor shaft does not turn due to improper lubrication. (Replace or repair as necessary.)
3. BLOWER FAILURE indicator lights, yet blower is operating.	<ul style="list-style-type: none"> a. Airflow restrictions present at Load Bank intake or exhaust. b. Improper fan blade rotation or phase reversal. (Check fan motor power connections for proper phase sequence.) c. Air Differential Pressure Switch is malfunctioning. d. Blower Fail Relay is malfunctioning.
4. Fan blade is broken or not turning.	<ul style="list-style-type: none"> a. Fan blade motion is obstructed. b. Fan blade is loose at hub or is not keyed properly.
5. Load step(s) cannot be energized.	<ul style="list-style-type: none"> a. A blower failure exists. (See problem 2.) b. MASTER LOAD Switch is inoperative. c. Control power is inadequate. d. Fuse is blown in Load Bank control circuit or individual branch circuit load fuse (if so equipped) is blown. (Check and replace as required.)* e. Blower Fail Relay is malfunctioning. f. Load step switch is inoperative. g. Load step contactor is inoperative. h. Magnetic contactor has an open coil. i. Load step resistor is open.

* When checking fuses for continuity, be sure to remove all fuses from clips (in fuseblock or Disconnect Switch). Test each fuse individually, out of circuit. (If tested in circuit, there is the possibility of feedback which causes false readings. A blown fuse may still check out OK.)

PROBLEM	POSSIBLE CAUSES/REMEDIES
6. Contactor "chattering" exists.	<ul style="list-style-type: none"> a. Contacts and/or core are dirty or corroded. b. Connections to contactor coil are loose. c. Control circuit line voltage is too low.
7. Load Bank or load step does not give rated load.	<ul style="list-style-type: none"> a. Applied load voltage is either derated or inadequate. b. Contactor does not close properly. c. Load step resistor element is open. d. One of the individual load branch circuit fuses is blown (if so equipped).
8. Disconnect Switch fuses are blown.	<ul style="list-style-type: none"> a. Fuses are undersized.* b. A short circuit exists in the blower or control circuit.*

* When checking fuses for continuity, be sure to remove all fuses from clips (in fuseblock or Disconnect Switch). Test each fuse individually, out of circuit. (If tested in circuit, there is the possibility of feedback which causes false readings. A blown fuse may still check out OK.)

KW-KVAR-KVA POWER FACTOR CHART

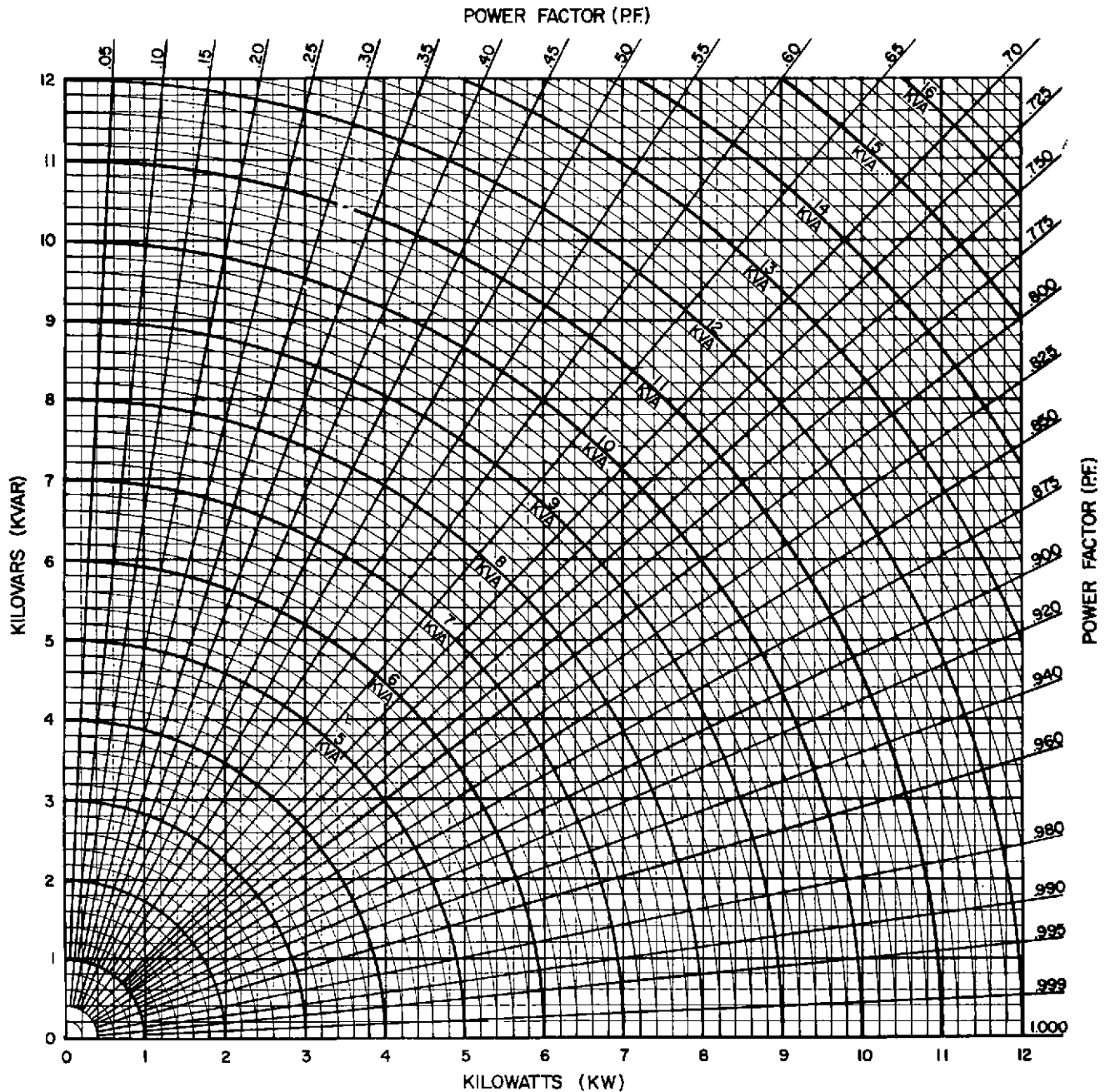

1. To find KVA and Power Factor follow the horizontal line from the KVAR value and the vertical line from the KW value. At the intersection of these lines is the KVA arc and the Power Factor radius.
2. To find KW and KVAR. From the intersection of the KVA arc and the Power Factor radius, a horizontal to the left gives KVAR, a vertical line down gives KW.
3. This chart can be used for values of KW, KVA, and KVAR greater or less than 1 thru 12 by using multiples of 10 on all quantities except Power Factor.



Parallel Operation of Resistive and Reactive Load Banks

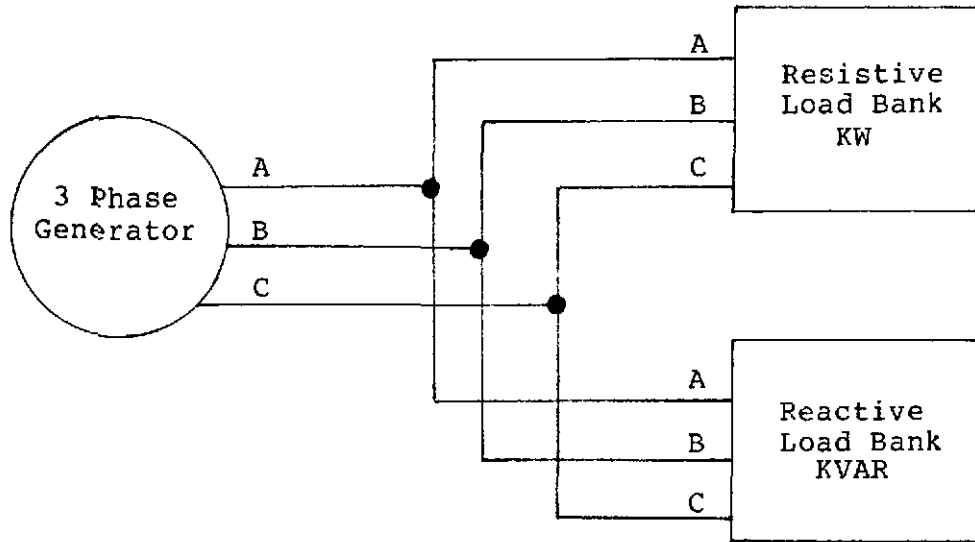

When using reactive and resistive load banks, wire them in parallel as shown above. To find the reactive load required to create a specific power factor, use the chart on the opposite side of this sheet. A table for 0.8 pf is shown below.

For 0.8 power factor					
KW	KVAR	KVA	KW	KVAR	KVA
5	3.75	6.25	700	525.00	875.00
10	7.50	12.50	750	562.50	937.50
25	18.75	31.25	800	600.00	1000.00
50	37.50	62.50	850	637.50	1062.50
75	56.25	93.75	900	675.00	1125.00
100	75.00	125.00	950	712.50	1187.50
150	112.50	187.50	1000	750.00	1250.00
200	150.00	250.00	1050	787.50	1312.50
250	187.50	312.50	1100	825.00	1375.00
300	225.00	375.00	1150	862.50	1437.50
350	262.50	437.50	1200	900.00	1500.00
400	300.00	500.00	1250	937.50	1562.50
450	337.50	562.50	1300	975.00	1625.00
500	375.00	625.00	1350	1012.50	1687.50
550	412.50	687.50	1400	1050.00	1750.00
600	450.00	750.00	1450	1087.50	1812.50
650	487.50	812.50	1500	1125.00	1875.00

Resistive Derating for Lower Voltages

$$\text{Actual KW} = \text{KW (rated)} \times \left(\frac{\text{Volts Applied}}{\text{Volts Rated}} \right)^2$$

Reactive Derating for Lower Voltages and Lower Frequencies*

$$\text{Actual KVAR} = \text{KVAR (rated)} \times \left(\frac{\text{Volts Applied}}{\text{Volts Rated}} \right)^2 \times \frac{\text{Rated Freq.}}{\text{Applied Freq.}}$$

*The voltage must be reduced proportionally to the frequency to avoid higher than rated currents in the reactor.

DRAWINGS

PROPRIETARY NOTE

The wiring diagrams and schematics which follow contain information PROPRIETARY to Avtron Manufacturing, Inc., are furnished solely to provide information sufficient for instruction, operation, maintenance, evaluation, and testing of the equipment herein disclosed, are not to be used for manufacturing or procurement and are not to be disclosed to anyone other than persons in the Division, or the Company, or the Government, as the case may be, responsible for action relating to this document without the express written permission of Avtron Manufacturing, Inc.

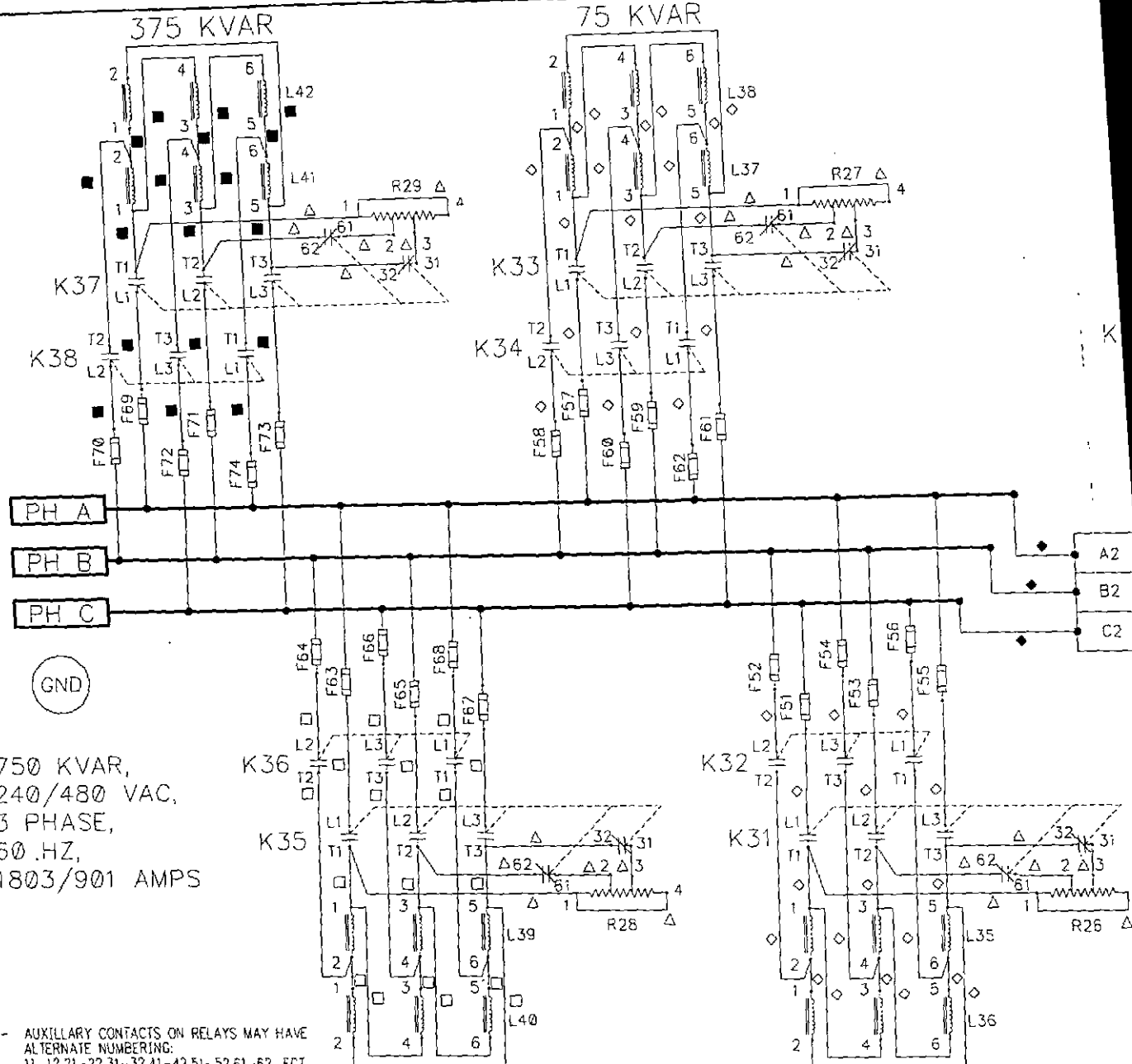

750 KVAR,
240/480 VAC,
3 PHASE,
60 .HZ,
1803/901 AMPS

13- AUXILIARY CONTACTS ON RELAYS MAY HAVE ALTERNATE NUMBERING: 11-12,21-22,31-32,41-42,51-52,61-62, ECT. ALTERNATE NUMBERING AND WIRING OF NORMALLY CLOSED AUX. CONTACTS IS ACCEPTABLE.

12-

- 11- PLACE #4/0 WIRE IN SINGLE LAYER WITH AIR SPACE BETWEEN WIRES.
- 10- LIMIT BUNDLING OF # 2 WIRE TO 3 WIRES.
- 9- ON ALL SHEETS WIRE COLOR TO BE BLACK UNLESS OTHERWISE NOTED
- 8- FUSES 70A AND HIGHER ARE BOLTED TO BUS BARS.
- 7- WIRE CODE: (SEE INDIVIDUAL SHEETS FOR SPECIFIC WIRE USED ON THAT SHEET.)

- ALL UNMARKED CONTROL WIRE TO BE #16 AWG (PN 390008).
- △ DENOTES WIRE TO BE #12 AWG, 105 DEG. C. (PN 390014).
- ◎ DENOTES WIRE TO BE #6 AWG, 105 DEG. C. (PN 390020).
- ◇ DENOTES WIRE TO BE #2 AWG, 105 DEG. C. (PN 390022).
- DENOTES WIRE TO BE #4/0 AWG, 105 DEG. C. (PN 390309).
- DENOTES WIRE TO BE 2 # 4/0 AWG, 105 DEG. C. (PN 390309) IN PARALLEL.
- ◆ DENOTES WIRE TO BE 2 #2 AWG, 105 DEG. C. (PN 390022).

- 6- TEST PER IS #725.
- 5- REFER TO NATIONAL ELECTRIC CODE FOR PROPER WIRE SIZE.
- 4- DASH LINES REPRESENT CUSTOMER WIRING. SOLID LINES REPRESENT AVTRON WIRING.

- 3-
- 2-
- 1-

UNLESS OTHERWISE SPECIFIED THE ABOVE NOTES APPLY

FUSE RATING
F1, F11, F12
F21, F23, F25
F22, F24, F26, F27, F29, F31
F28, F30, F32, F34, F36, F38
F39, F41, F43
F40, F42, F44, F45 TO F50
F51 TO F62
F63 TO F68
F69 TO F74

ECN NO.	REV	DESCRIPTION	DATE	APPROVED
AB076	A	REVISED SHEET 2	GILLISSIE 3/14/95	NEUMEYER
AC717	B	REVISED PER ECN	GILLISSIE 6/24/96	MITCHELL
AD529	C	REMOVED NOTE 12	M. DEMIN 12/13/96	NEUMEYER
CA433	D	REVISED SHEET 2	KONTRA 12/13/97	NEUMEYER
CC490	E	REVISED SHEET 2	FACKELMANN 1/31/01	MITCHELL
CC549	F	REVISED SHEET 2	J. FLAUT 2-15-01	D. KOZAR

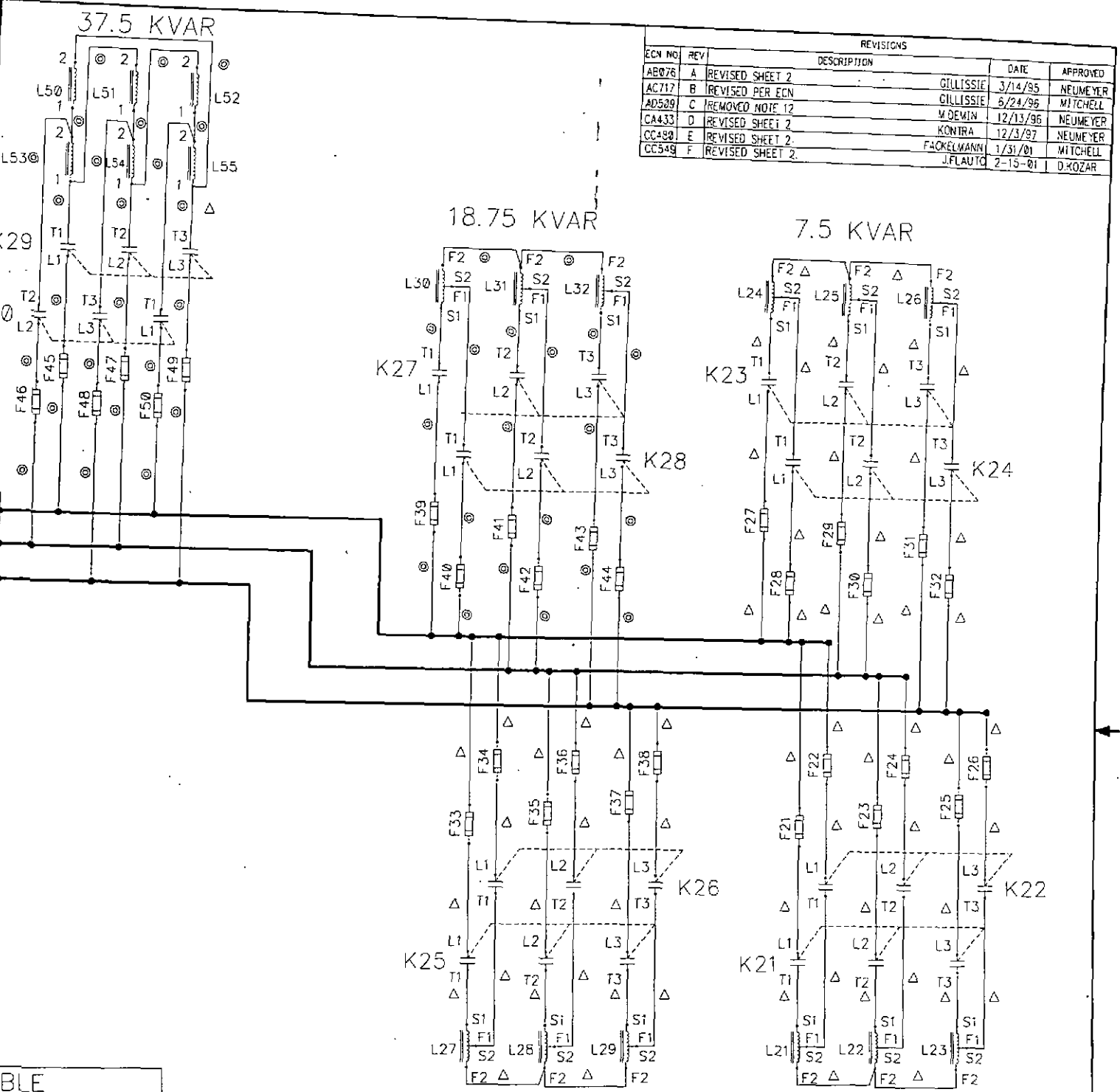

Component	Rating
12 A	
10 A	
F35, F37	15 A
25 A	
35 A	
60 A	
125 A	
250 A	
600 A	

UNLESS OTHERWISE SPECIFIED DIMENSIONS ARE IN INCHES		DRAWN	DATE	7388 E. PLEASANT VALLEY ROAD INDEPENDENCE, OH 44131-5529
TOLERANCES- DECIMALS .XX± ANGLE±1' .XXX±		CHECKED	ZMECEK 11/10/94	
FINISH		ENG APVD	L. NEUMEYER 11/10/94	SCHEMATIC/INTCON DIAG. 750KVAR, LOAD BANK, 3.75KVAR RES 240/480VAC, 3 PHASE, 60 HZ
PAINT PER PS		APVD PROD	B. GREEN 11/18/94	
K841B	D23154	SIZE		INF
NEXT ASSY	USED ON	D 01014		PSF
APPLICATION	OTHER	DWG NO D23166		REV F
		SCALE NONE MODEL K841B		SHEET 1 OF 2

154

REVISIONS				
ECN NO.	REV	DESCRIPTION	DATE	APPROVED
AB076	A	REVISED PER ECN	GILLISSIE 3/14/95	NEUMEYER
AC717	B	REMOVED THERMAL SWITCHES TO K49	GILLISSIE 6/24/96	MITCHELL
CA433	D	REVISED BLOWER	KONTRA 12/3/97	NEUMEYER
CC480	E	REV PER ECN	FACKELMANN 1/31/01	MITCHELL
CC549	F	REVISED S2 WIRING	JFLAUTO 2-15-01	KOZAR

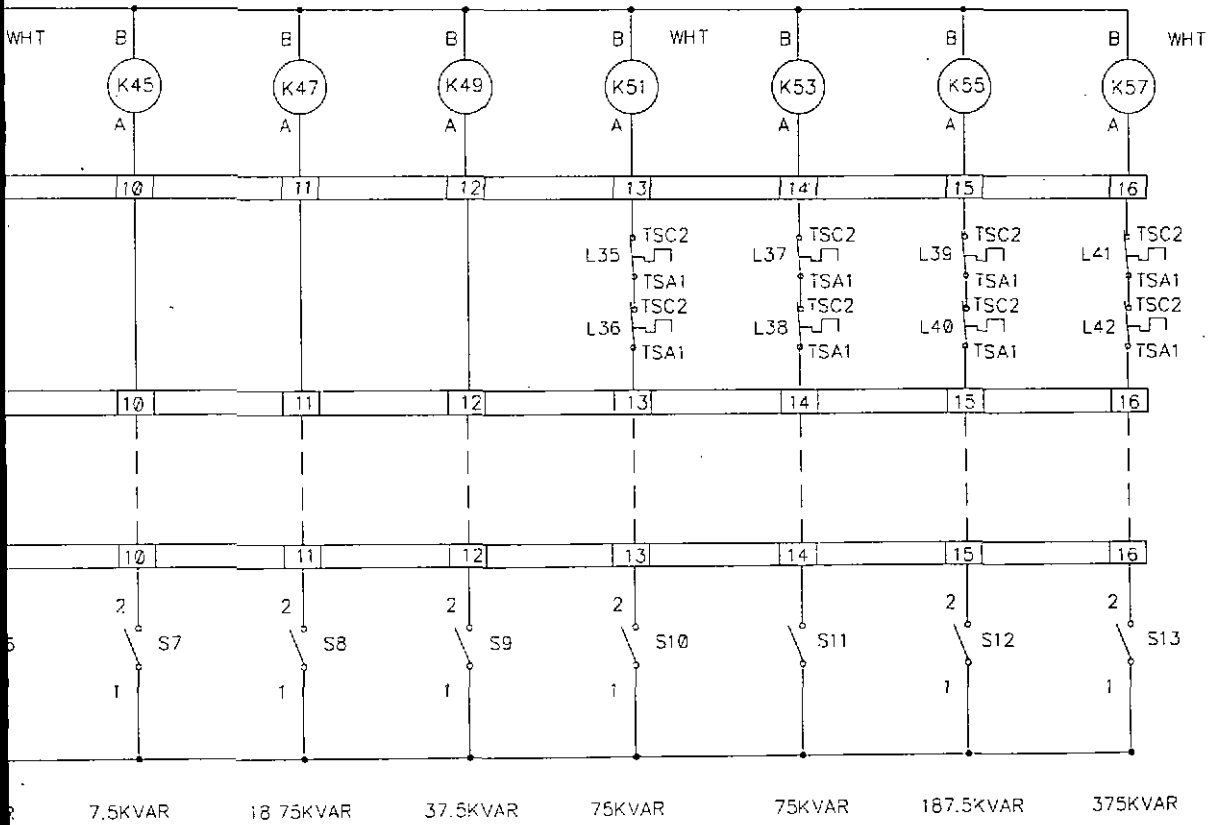
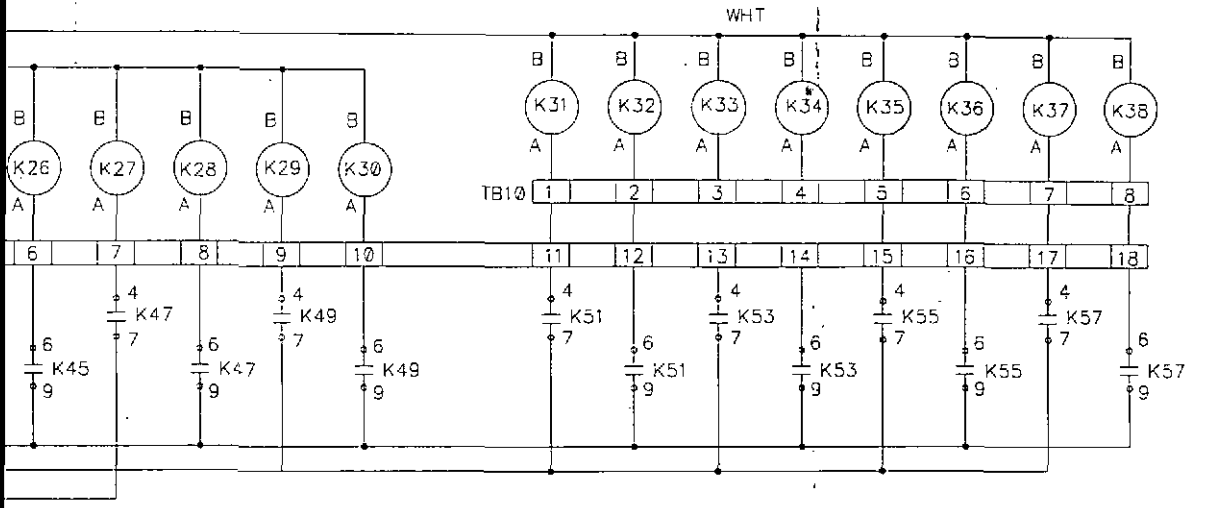

REACTOR
OVERTEMP
SWITCHES

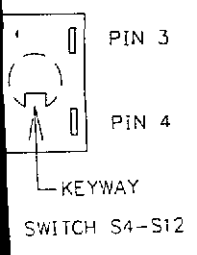

UNLESS OTHERWISE SPECIFIED DIMENSIONS ARE IN INCHES		DRAWN	DATE	7933 E. PLEASANT VALLEY ROAD INDEPENDENCE, OH 44131-5529	
TOLERANCES: ANGLES ±1°		ZMECEK	11/10/94	★ AVTRON MANUFACTURING INC.	
DECIMALS .XX±		CHECKED		SHEETS	
FINISH		ENG. APPROV.		SCHEMATIC/INTCON DIAG.	
PAINT PER PS		L. NEUMEYER	11/10/94	750KVAR, LOAD BANK, 3.75KVAR RES	
PLATE PER		APPROV. PROD.		240/480VAC, 3 PHASE, 60 HZ	
COAT PER PS		B. GREEN	11/18/94	SIZE D CAGE NO. 01014 DWG. NO. D23166	
ANODIZED PER				SCALE NCNE MODEL K841B SHEET 2	
OTHER				REV	
APPLICATION					

↑

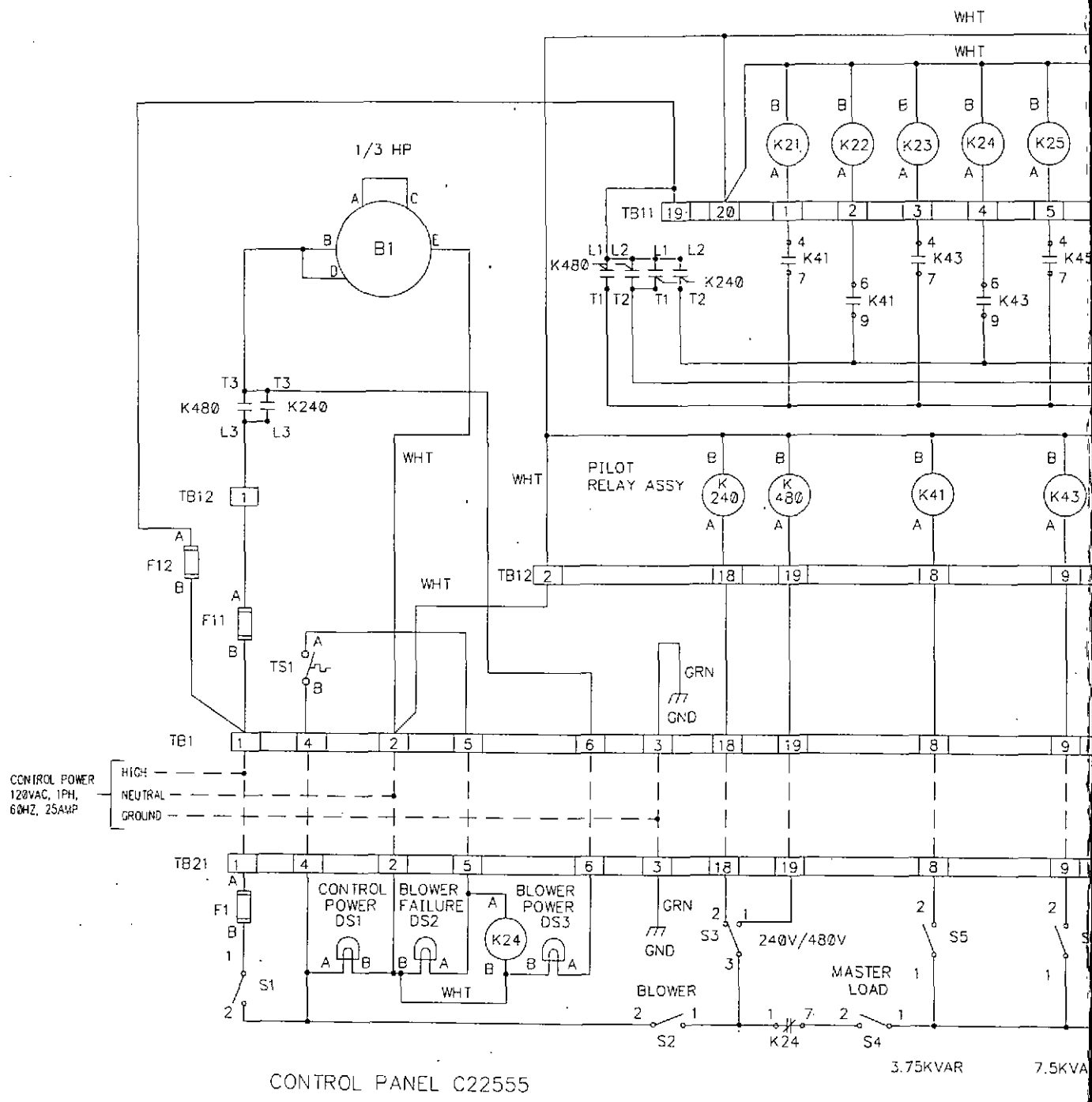

- 7- MAXIMUM CYCLE RATE OF 3 CYCLES PER MINUTE.
- 6- REACTORS REQUIRE SEVERAL SECONDS TO REACH RATED CURRENT.
- 5- ALL WIRES ON THIS SHEET ARE #16 AWG (PN 39000B). UNLESS OTHERWISE NOTED. ALL WIRES ARE BLACK UNLESS OTHERWISE NOTED. REFER TO SHEET 1 FOR NOTES.

UNLESS SPECIFIED THE ABOVE NOTES APPLY

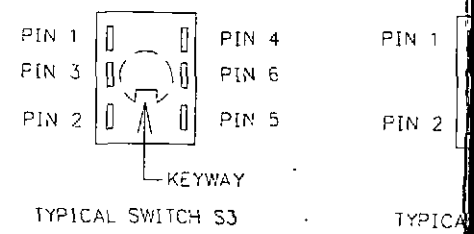

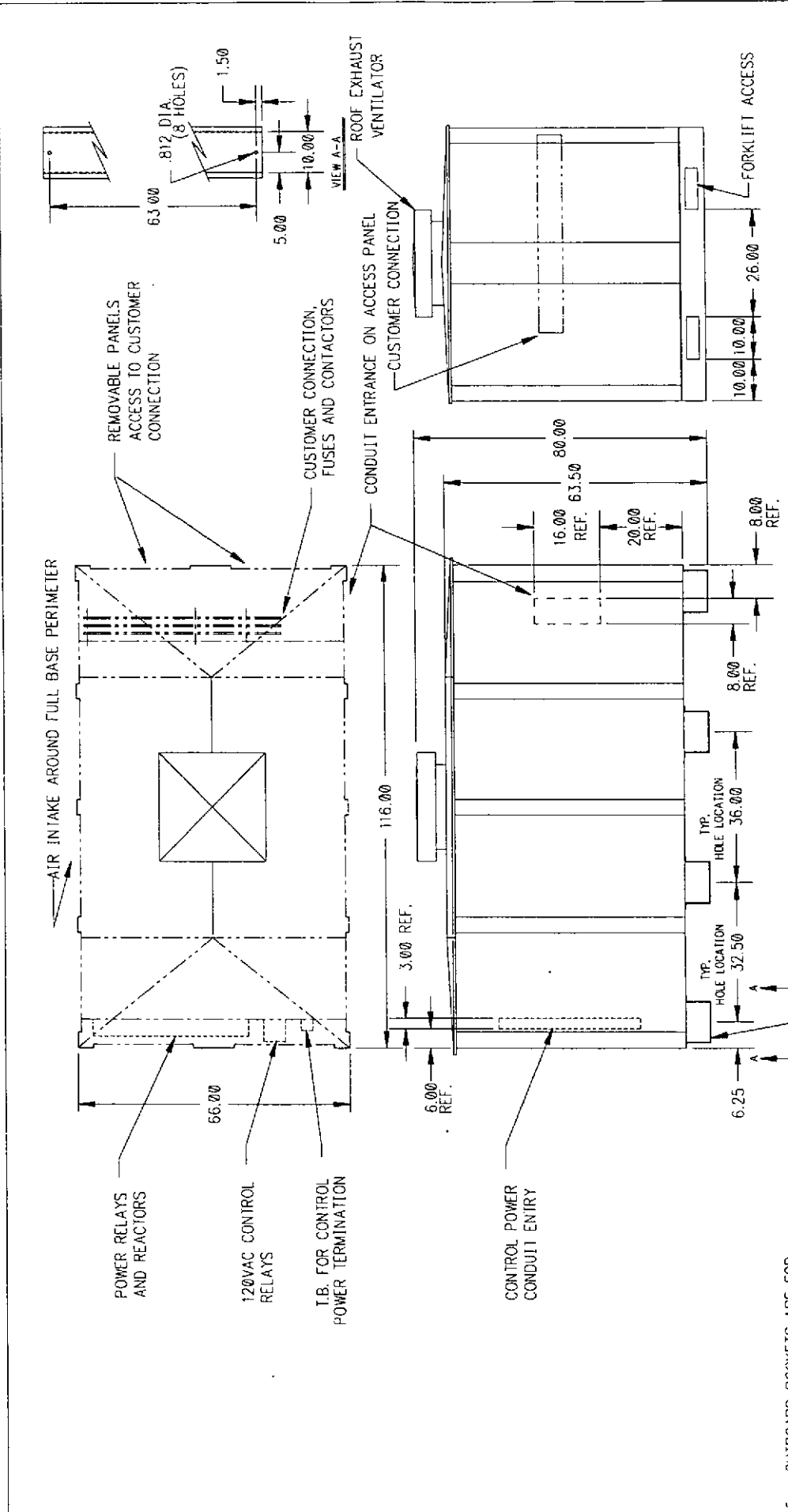

FOR APPLICATION ENGINEERING USAGE ONLY

DRAWN: E. JAMICOI		DATE: 1-8-92		DRAWING NUMBER: SB2159	
CHECKED: EMERY		APPROVED: J. LEMERY		OUTLINE DRAWING	
REVISOR: B		REVISION: A		PROJECT: LOAD BANK REACTIVE	
ECONOMY: ECK		REVISION: REV		PART NUMBER: K841B	
LET.:		CHANGE:			

- NOTES:
- 5 - OUTBOARD POCKETS ARE FOR HOISTING LOADBANK. SPREADER BAR REQUIRED.
 - 4 - MIN. 2FT CLEARANCE BETWEEN ENCLOSURE AND ANY OBSTRUCTION.
 - 3 - CAPACITY:
 2. ALL DIMENSIONS ARE APPROX.
 1. WEIGHT:

SEE NOTE: -5

REVISED		REVISIONS		DATE		APPROVED	
ECN NO	LTR	DESCRIPTION	REV PER	ECN	DATE	DATE	APPROVED
CC557	A				7/22/01		R MITCHELL

ASSEMBLY INSTRUCTIONS

- INSTALL FREQUENCY SENSOR K101 ON PILOT RELAY ASSEMBLY (PART OF K841B LOAD BANK). IF ADEQUATE SPACE EXISTS, K101 MAY BE ALTERNATELY INSTALLED ON EXISTING MOUNTING RAIL. IN THIS CASE, DISCARD EXTRA MOUNTING RAIL AND BRACKETS.
- WIRE K101 PER SCHEMATIC/WIRING DIAGRAM.
- INTERRUPT THE WIRE FROM TB11(19) AND K480(L1) (REFER TO LOAD BANK SCHEMATIC), AND INSERT K101 N.C. CONTACT IN LINE AS SHOWN.
- UNLESS OTHERWISE NOTED, ALL WIRES TO BE BLACK #16 AWG (PN 3900008).

TEST INSTRUCTIONS

- ADJUST K101 UNDERFREQUENCY SETTING TO 5HZ. SET DIFFERENTIAL TO MINIMUM.

SCHEMATIC/WIRING DIAGRAM

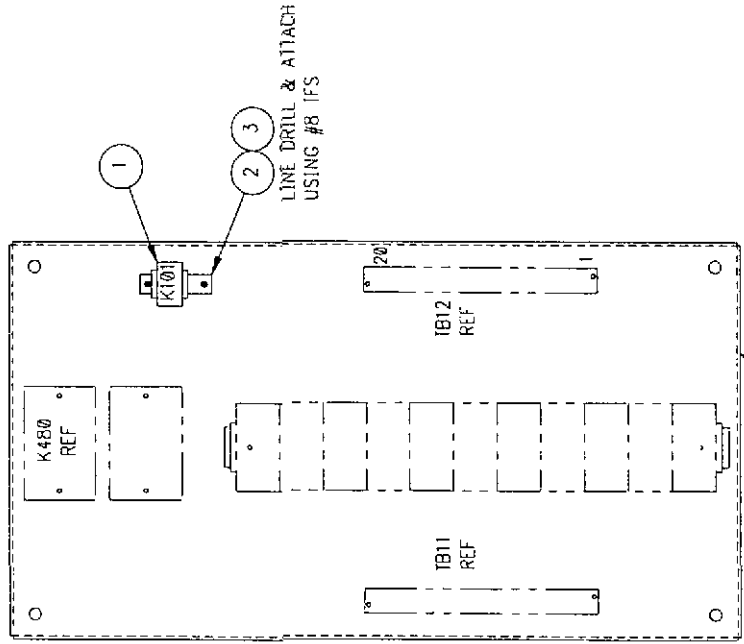
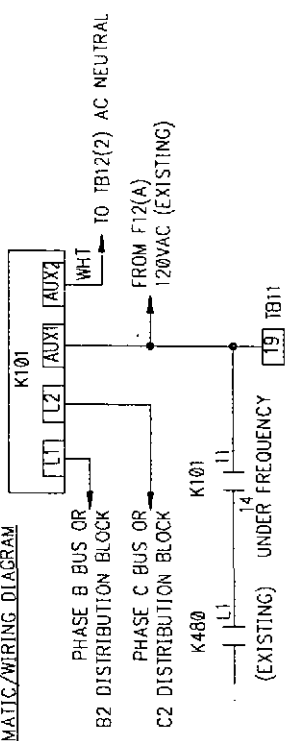

PILOT RELAY ASSEMBLY
(PN D23225 THRU D23230)
PART OF K841B LOAD BANK

REF DES	ITEM NO.	NO. RECD	PART NO	DESCRIPTION	MATERIAL
	4				
	3	2	364291	END BRACKET	
	2	5	408189	MOUNTING RAIL	
K101	1	1	350565	RELAY, FREQUENCY SENSOR	

LIST OF MATERIAL

UNLESS OTHERWISE SPECIFIED DIMENSIONS ARE IN INCHES	DRAWN	CHECKED	DATE	BY
	J. FLAUTIC	J. FLAUTIC	1-12-01	
TOLERANCE S:	ENG APP'D	R. MITCHELL	1/15/01	
DECIMALS: .XXX, .015	APPRO PROD	T. PLISKO	1/15/01	
ANGLES: ±1°, .XXX, 0.3	FINISH			
	PAINT PER PS			
	ZINC PLATE PER			
	COAT PER PS			
	ANODIZE PER			
	OTHER			

UNLESS OTHERWISE SPECIFIED DIMENSIONS ARE IN INCHES	DRAWN	CHECKED	DATE	BY
	J. FLAUTIC	J. FLAUTIC	1-12-01	
TOLERANCE S:	ENG APP'D	R. MITCHELL	1/15/01	
DECIMALS: .XXX, .015	APPRO PROD	T. PLISKO	1/15/01	
ANGLES: ±1°, .XXX, 0.3	FINISH			
	PAINT PER PS			
	ZINC PLATE PER			
	COAT PER PS			
	ANODIZE PER			
	OTHER			

THIS DOCUMENT CONTAINS PROPRIETARY INFORMATION OF AVTRON MFG INC AND MAY NOT BE DISCLOSED TO OTHERS WITHOUT THE WRITTEN CONSENT OF AVTRON MFG.

1. MARK REFERENCE DESIGNATORS .12 HIGH MINIMUM USING PRODUCTION DECALS AND OR INK STAMPING.

UNLESS OTHERWISE SPECIFIED THE ABOVE NOTES APPLY.

UNLESS OTHERWISE SPECIFIED DIMENSIONS ARE IN INCHES	DRAWN	CHECKED	DATE	BY
	J. FLAUTIC	J. FLAUTIC	1-12-01	
TOLERANCE S:	ENG APP'D	R. MITCHELL	1/15/01	
DECIMALS: .XXX, .015	APPRO PROD	T. PLISKO	1/15/01	
ANGLES: ±1°, .XXX, 0.3	FINISH			
	PAINT PER PS			
	ZINC PLATE PER			
	COAT PER PS			
	ANODIZE PER			
	OTHER			

UNLESS OTHERWISE SPECIFIED DIMENSIONS ARE IN INCHES	DRAWN	CHECKED	DATE	BY
	J. FLAUTIC	J. FLAUTIC	1-12-01	
TOLERANCE S:	ENG APP'D	R. MITCHELL	1/15/01	
DECIMALS: .XXX, .015	APPRO PROD	T. PLISKO	1/15/01	
ANGLES: ±1°, .XXX, 0.3	FINISH			
	PAINT PER PS			
	ZINC PLATE PER			
	COAT PER PS			
	ANODIZE PER			
	OTHER			

UNLESS OTHERWISE SPECIFIED DIMENSIONS ARE IN INCHES	DRAWN	CHECKED	DATE	BY
	J. FLAUTIC	J. FLAUTIC	1-12-01	
TOLERANCE S:	ENG APP'D	R. MITCHELL	1/15/01	
DECIMALS: .XXX, .015	APPRO PROD	T. PLISKO	1/15/01	
ANGLES: ±1°, .XXX, 0.3	FINISH			
	PAINT PER PS			
	ZINC PLATE PER			
	COAT PER PS			
	ANODIZE PER			
	OTHER			

UNLESS OTHERWISE SPECIFIED DIMENSIONS ARE IN INCHES	DRAWN	CHECKED	DATE	BY
	J. FLAUTIC	J. FLAUTIC	1-12-01	
TOLERANCE S:	ENG APP'D	R. MITCHELL	1/15/01	
DECIMALS: .XXX, .015	APPRO PROD	T. PLISKO	1/15/01	
ANGLES: ±1°, .XXX, 0.3	FINISH			
	PAINT PER PS			
	ZINC PLATE PER			
	COAT PER PS			
	ANODIZE PER			
	OTHER			

SCALE 1/8" = 1"

MODEL K841B

DRAWING NO B28144

SIZE B

OPTION #4

UNDERFREQUENCY PROTECTION

AVTRON MANUFACTURING, INC.

7882 E PLEASANT VALLEY ROAD
INDEPENDENCE, OH 44131-5528

SHEET 1 OF 1

SIM 10 B2691.3

REVOLUTIONS		DATE	APPROVED
ECN NO.	1		
LTR	A		
CC557			
REV PER ECN			
DESCRIPTION	FACKELMANN 2/22/01 R MITCHELL		

ASSEMBLY INSTRUCTIONS

- A) INSTALL VOLTAGE SENSOR K102 ON PILOT RELAY ASSEMBLY (PART OF K841B LOAD BANK). K102 MAY BE INSTALLED ON MOUNTING RAIL AS SHOWN OR ALTERNATELY INSTALLED ON EXISTING RAIL, OR INSTALLED WITH FREQUENCY SENSOR, IF THAT OPTION IS INCLUDED. IN THIS CASE, DISCARD EXTRA MOUNTING RAIL AND BRACKETS.
- B) WIRE K102 PER SCHEMATIC/WIRING DIAGRAM. UNLESS OTHERWISE NOTED, ALL WIRES TO BE BLACK #16 AWG (PN 3900008).
- C) ATTACH RESISTOR R102 (ITEM 4) ACROSS TERMINALS 4 AND 5 OF TB12 SLEEVE RESISTOR LEADS.
- D) INTERRUPT THE WIRE FROM TB12(18) TO K240(A) (REFER TO LOAD BANK SCHEMATIC), AND INSERT K102 N.C. CONTACT IN LINE AS SHOWN.

TEST INSTRUCTIONS

- 1) ADJUST K102 FOR 300V AND 0% HYSTERESIS.

SCHEMATIC/WIRING DIAGRAM

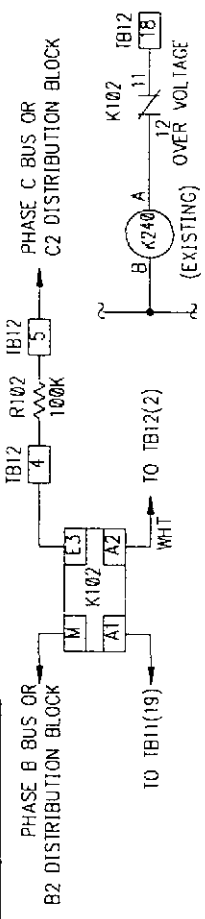

REF	DES	ITEM NO.	NO REQD.	PART NO.	DESCRIPTION	MATERIAL
R102		4	1	110048	RESISTOR, 100K, 1/2W	
		3	2	364291	END BRACKET	
		2	5	408189	MOUNTING RAIL	
K102		1	1	351653	RELAY, VOLTAGE SENSE	

LIST OF MATERIAL

UNLESS OTHERWISE SPECIFIED DIMENSIONS ARE IN INCHES	DRAWN	CHECKED	ENG APPD	APPRO PRCD	DATE	NO-RECD
TOLERANCES: DECIMALS .XXX± Ø15 ANGLES±1' .XX± Ø3	JFLAUTC	JFLAUTC	R MITCHELL	TPLSKD	1-12-01	1/15/01
FINISH					1/15/01	
PAINT PER PS						
ZINC PLATE PER						
COAT PER PS						
ANODIZE PER						
OTHER						

AVTRON MANUFACTURING, INC.
 2923 E. PLEASANT VALLEY ROAD
 INDEPENDENCE, OH 44131-9579

OVERVOLTAGE PROTECTION
 OPTION #5

SIZE: B
 CASE NO: 01014
 DRAWING NO: B28145

SCALE: 1/8
 MODEL: K841B
 SHEET 1 OF 1

THIS DOCUMENT CONTAINS PROPRIETARY INFORMATION OF AVTRON MFG INC AND MAY NOT BE DISCLOSED TO OTHERS WITHOUT THE WRITTEN CONSENT OF AVTRON MFG

1. MARK REFERENCE DESIGNATORS .12 HIGH MINIMUM USING PRODUCTION DECALS AND OR INK STAMPING.

UNLESS OTHERWISE SPECIFIED THE ABOVE NOTES APPLY.

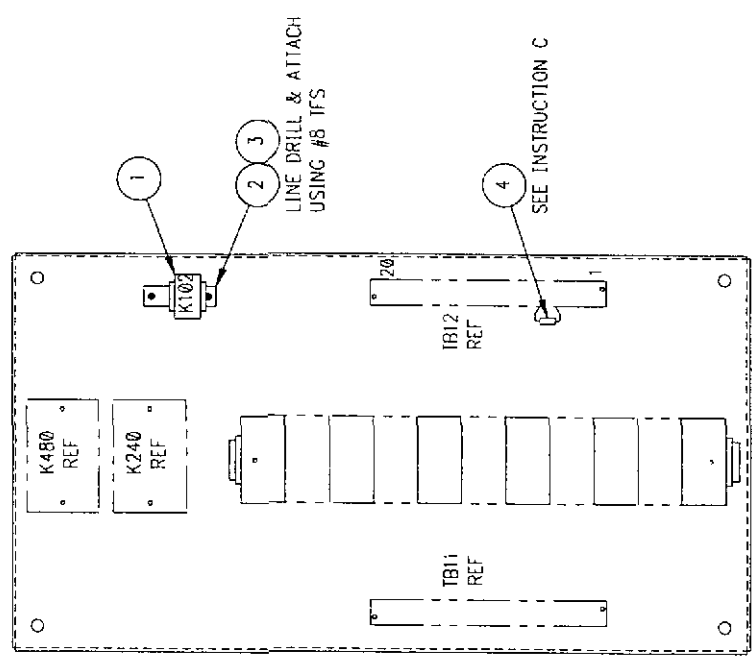

PILOT RELAY ASSEMBLY (PN D23225 THRU D23230) PART OF K841B LOAD BANK

SIM TO B26013

Warranty

Warranty and Duration

For a period of one year after installation, or fifteen (15) months from date of shipment from our plant, whichever is shorter, Avtron warrants the equipment, except as hereinafter provided, to be free from harmful defects in material and workmanship. Notwithstanding any other term or provision in this Warranty, the warranty provided herein shall terminate unless buyer notifies Avtron, in writing, of a breach hereof within the warranty period; any claims not made within such period are waived by Buyer. The warranty provided herein applies only if Buyer complies with all the other terms and provisions of this Warranty.

Uses of Equipment

The warranty provided herein applies only if the equipment has been used in a normal and proper manner under recommended conditions. Notwithstanding any advice or assistance given to the Buyer by Avtron or its suppliers concerning the equipment or its use, Avtron makes no express or implied warranties or representations, except as herein expressly provided, with respect to the equipment or its use, and Avtron shall not be liable in contract, warranty or tort (including, without limitation, for negligence or strict liability) as a result of such advice or assistance. In addition, unless otherwise agreed in writing signed by a duly authorized representative of Avtron, no equipment covered by this warranty is intended to be used in connection with any nuclear facility or activity, and if so used, Avtron disclaims any and all liability for any damage resulting therefrom.

Notification of Breach

When claiming a breach of this Warranty, Buyer must promptly (within 10 days from the date of the discovery of the defect) notify Avtron in writing.

Equipment Disposition

Upon notification of a claimed breach of this Warranty, Avtron, at its discretion, will either authorize the return of the defective equipment or part thereof (transportation costs to be prepaid by Buyer) or provide a suitable replacement or authorize the Buyer in writing to effect repairs at Avtron's expense. In the event that the equipment returned as authorized is found to be defective and Avtron elects to repair or replace said equipment, Avtron will pay the transportation costs associated with the return of said equipment to Buyer. Avtron shall not however be liable for any customs, tariffs, duties or taxes incurred in shipping equipment pursuant to this Warranty. These shall be the responsibility of the Buyer.

Option of Avtron to Repair or Replace Equipment or to Issue Credit

Avtron's sole obligation under this Warranty shall be, at the option of Avtron, to replace or repair any defective equipment or part thereof or to issue a credit with respect to the defective equipment equal to the purchase price thereof less depreciation.

Equipment Excluded From Warranty

The warranty provided herein specifically excludes equipment and components that Avtron purchases and resells as part of a system, product or spare part order. The warranties provided to Avtron by the manufacturers of the foregoing equipment and components will, to the extent possible, be passed on to the Buyer. Copies of such warranties, if on file at Avtron, will be made available for inspection upon the request of Buyer. Equipment such as, but not limited to, computers, CRTs, operator interface modules, monitors, etc., normally have a short warranty period and should be covered by a continuous service contract generally available from the original manufacturer at a reasonable cost. Consumable items including, but not limited to, lamps, filters, fuses and motor brushes are excluded from all warranties. Other items or components may be excluded from this warranty if so noted in the governing purchase order or contract.

Resale or Lease of Equipment

In the event that the Buyer resells or leases equipment purchased from Avtron, the Buyer shall obtain the signed written agreement of the purchaser or lessee thereof that Avtron's only liability with respect to said equipment is as set forth in this Warranty. In the event that the Buyer fails to obtain such a signed written agreement, the Buyer agrees to indemnify Avtron against any claims, demands, judgments, suits, costs, liabilities and expenses (including reasonable attorney's fees) incurred by Avtron as a result of such failure.

Unauthorized Repairs

Unless otherwise agreed in writing signed by a duly authorized representative of Avtron, if the Buyer has repairs or modifications made to equipment covered by this Warranty by a person other than an authorized Avtron service representative, Avtron shall not be liable for any expenses incurred in connection therewith and the warranty provided herein shall automatically be terminated.

Governing Law; Saving Clause

This Warranty is part of the terms and conditions of the sale of the equipment covered hereunder and shall be governed by and enforced in accordance with the laws of the State of Ohio. Any provision hereof which is prohibited or unenforceable in any jurisdiction shall, as to such jurisdiction, be ineffective to the extent of such prohibition or unenforceability without invalidating the remaining provisions hereof or affecting the validity or enforceability of such provision in any other jurisdiction.

Limitation of Liability

IN NO EVENT SHALL AVTRON BE LIABLE IN CONTRACT, IN TORT OR OTHERWISE FOR SPECIAL, INCIDENTAL, CONSEQUENTIAL OR PUNITIVE DAMAGES (INCLUDING, BUT NOT LIMITED TO, LOSS OF PROFITS OR REVENUES, LOSS OF USE OF THE EQUIPMENT OR ANY DAMAGE TO ASSOCIATED EQUIPMENT, DAMAGE OR INJURY TO PERSONS OR PROPERTY, COST OF CAPITAL, COST OF SUBSTITUTE OR TEMPORARY EQUIPMENT, DOWNTIME OR CLAIMS OF CUSTOMERS) ARISING OUT OF OR AS A RESULT OF BREACH OF WARRANTY, DEFECT IN MATERIAL OR WORKMANSHIP OR ANY OTHER OBLIGATION OF AVTRON HEREUNDER.

Disclaimer of All Other Warranties

THIS WARRANTY COMPRISES AVTRON'S SOLE AND ENTIRE WARRANTY OBLIGATION TO BUYER, ITS CUSTOMERS AND ASSIGNS IN CONNECTION WITH EQUIPMENT SOLD, ASSIGNED, LEASED OR OTHERWISE DEALT WITH BY AVTRON. ALL OTHER WARRANTIES, EXPRESS OR IMPLIED, INCLUDING, BUT NOT LIMITED TO, WARRANTIES OF MERCHANTABILITY AND FITNESS, ARE EXPRESSLY EXCLUDED.

