

**AVTRON MODEL LPH100  
AC LOAD BANK  
Part Number LPH100D34963**

100 kW @ 480V, 3-Phase, 60 Hz  
93.75 kW @ 240V, 3-Phase, 60 Hz

© 2003 Avtron Manufacturing, Inc.  
Cleveland, Ohio

June 10, 2003  
Rev. Feb. 16, 2005  
Rev. Dec. 19, 2005

## PROPRIETARY NOTE

This document contains information PROPRIETARY to Avtron Manufacturing, Inc., is furnished solely to provide information sufficient for instruction, operation, maintenance, evaluation, and testing of the equipment herein disclosed, is not to be used for manufacturing or procurement and is not to be disclosed to anyone other than persons in the Division, or the Company, or the Government, as the case may be, responsible for action relating to this document without the express written permission of Avtron Manufacturing, Inc.

## WARRANTY

The last page of this document contains an express limited warranty. The provisions of this warranty cover any and all rights extended to holders of Avtron equipment.

AVTRON MANUFACTURING, INC.  
Cleveland, Ohio

AVTRON MODEL LPH100  
AC LOAD BANK  
Part Number LPH100D34963

TABLE OF CONTENTS

| <u>Section</u> |                             | <u>Page</u> |
|----------------|-----------------------------|-------------|
| I              | SAFETY CONSIDERATIONS.....  | 1-1         |
| II             | DESCRIPTION .....           | 2-1         |
| III            | INSTALLATION.....           | 3-1         |
| IV             | OPERATION.....              | 4-1         |
| V              | MAINTENANCE.....            | 5-1         |
| VI             | REPLACEMENT PARTS LIST..... | 6-1         |

APPENDIX - Avtron Load Bank Troubleshooting Guide

DRAWINGS

|              |                               |
|--------------|-------------------------------|
| SB3192       | Outline Drawing, Load Bank    |
| D34965       | Schematic                     |
| B28571       | Cable Set - 20 Ft. (Option 1) |
| LPH100D34963 | Load Bank, Portable, Indoor   |

VENDOR DATA

|                                     |  |
|-------------------------------------|--|
| Cooper Crouse-Hinds Molded Products | Cam-lok7 Assembly Instructions, Series E1016 & E1018 SAW254, 9/26/01   |
| Multitek                            | MultiDin M801-MD*, M802-MD*<br>Operating Manual, Revision 4, 10/9/2003 |

**AVTRON MODEL LPH100  
AC LOAD BANK  
Part Number LPH100D34963**

**SECTION I  
SAFETY CONSIDERATIONS**

Throughout this manual, you will find **WARNING** and **CAUTION** statements. Personal injury or death may occur to an operator using or repairing the equipment if a **WARNING** statement is ignored. Damage to the equipment and potentially hazardous conditions for personnel may occur if a **CAUTION** statement is ignored.

Each Avtron unit is safety checked for opens and shorts, and the insulation is high potential tested to ensure safe operation. All fuses, safety interlocks, and related safety equipment have been proven reliable as part of the testing procedure of each unit.

As part of your safety program, an initial inspection after receiving the unit(s) and periodic preventive maintenance and safety inspections should be conducted to ensure the reliability and safety built into your Avtron equipment.

*The Model LPH100 Load Bank is an industrial test unit designed to be used indoors. However, because the function of the Load Bank is to dissipate electrical energy, there are inherent dangers to the operator and to the equipment. These dangers shall be outlined in this section.*

Electrical energy is transformed into heat by the resistor elements. The heat may be removed from the Load Bank by airflow through the resistor elements. If there are any restrictions or stoppage of airflow, the Load Bank may overheat and may even start a fire. The following recommendations are made:

1. Read the manual before operating the Load Bank.
2. Run an approved ground wire from the Load Bank ground lug located on the customer connection panel to the frame of the power source. Run an approved ground wire from the power source frame to a good earth ground. Size ground wire in accordance with National Electrical Code and any local codes.
3. Do not bypass the temperature sensing switches to prevent nuisance tripping. The switches will drop out the load if insufficient cooling air is reaching the elements.
4. Replace any burned out bulbs on the control panel. Each lamp is an indication that a system is active or has failed and is important to the operation of the unit and safety of the operator.

\*\*\*\*\*

**W A R N I N G**

Personal injury from electrical shock may result if all sources of power are not disconnected before servicing. Maintenance work must be done only by qualified personnel.

\*\*\*\*\*

5. Maintenance should be performed with no power on the unit. The majority of troubleshooting can be performed with an ohmmeter. There are multiple sources of power input to the Load Bank. Ensure each is disconnected.
6. Venting the heated air from the exhaust toward overhead cables, sprinkler systems, or into a room with insufficient volume or "Make-Up" air, is a potential hazard. The Load Bank should be used in a cool, well-ventilated area.
7. Allow cool room air to pass into the unit to cool the elements. Do not allow the unit to be placed where hot exhaust air can recirculate back through the unit causing a constant rise in cooling air temperature.
8. After running a load test, residual heat may be removed from the Load Bank by allowing the blower to operate for a few minutes after load is removed. This procedure is not required for maintaining Load Bank integrity, but it may guard operating personnel from possible burn injuries.
9. The operator should avoid coming in contact with the resistor elements or surrounding covers during and for some time after operation. These portions of the Load Bank become quite hot and may result in a serious burn should contact be made with them.
10. Do not allow objects to enter or block the air intake or exhaust of the Load Bank. A blockage would cause Load Bank overheating. If an object enters the screens, it will cause damage to the resistor elements, possibly shorting them and causing shock and fire hazards.
11. Emergency Shutdown Procedure
  - A. In an emergency, shut down the MASTER LOAD switch, then the power source. The MASTER LOAD switch will allow disconnection of all load steps and still allow for motor to run, cooling any heated elements.
  - B. The POWER ON/OFF switch will disconnect both load steps and fan motor. The power source EMERGENCY OFF switch should be located near the load system.
12. An approved electrical fire extinguisher should be on hand at all times.

13. It is the responsibility of the customer to take diligent care in installing the Load Bank. The National Electrical Code (NEC), sound local electrical and safety codes, and the Occupational Safety and Health Act (OSHA) should be followed when installing the equipment to reduce hazards to persons and property.
14. Read and heed all **WARNING** and **CAUTION** statements in the manual.

## SECTION II

### DESCRIPTION

The Avtron Model LPH100 Load Bank is designed for electrically loading and testing power sources. The Load Bank is designed for production line and job site use.

The loading capability of the Load Bank depends on voltage. At 480 volts, 3-phase, 60 Hz, the total load is 100 kW with fixed load steps of 5, 10, 10, 25, and 50 kW. At 240 volts, 3-phase, 60 Hz, the total loading capability is 93.75 kW with fixed load steps of 3.75, 7.5, 7.5, 25, and 50 kW. Using the toggle switches on the control panel, any combination of the available load steps may be selected to achieve a desired load.

120V, single phase, 60 Hz, 5 amp power source is required for the fan and control circuits. This power is derived from the control power receptacle located on the side of the unit.

#### CONTROL PANEL

The loads described above are controlled from a single control panel. The control panel is integrally mounted on the side of the Load Bank. The arrangement of the control panel is:

1. POWER ON/OFF switch - Applies power to the Load Bank and starts the blowers. The CONTROL POWER indicator lights when power is applied.
2. OVER TEMP indicator - Indicates an air failure condition OR insufficient cooling airflow.
3. MASTER LOAD ON/OFF switch - Allows instantaneous connection and disconnection of all switched ON load steps.
4. KW LOAD STEPS switches - Connect and disconnect load steps. Values are shown above each switch.
5. Digital Meter - Monitors volts, amps, kW, and frequency applied to Load Bank.
6. VOLTAGE SELECT switch - Configures load resistor circuit for 240V or 480V application.

**ENCLOSURE**

The outside dimensions of the Model LPH100 Load Bank are shown on Outline Drawing SB3192. The Load Bank is fabricated of aluminized steel, assembled with SST hardware, and mounted on four casters. Handles are provided for lifting the Load Bank when it is being transported.

\*\*\*\*\*

**CAUTION**

Do not allow the Load Bank to be placed where hot exhaust air can recirculate back through the unit causing a constant rise in cooling air temperature.

\*\*\*\*\*

The Load Bank contains blowers (approximately 75 dBA at 3 ft.) which provide the necessary cooling air for the load elements. Exhaust temperature sensors are provided to monitor the flow of cooling air. These switches are electrically interlocked with the load application. If the blower is not working properly, the OVER TEMP light comes on and the load steps are disabled.

Air to cool the load elements enters the screened intakes located on one end of the Load Bank. The air passes over the resistive elements and is then discharged through the screened opening at the other end of the Load Bank.

The Load Bank also contains fuses for short circuit protection. The control circuit is protected with a 5 amp fuse while the voltage signals to the meter are protected with 1 amp fuses. The load circuit is protected with three 300 amp main line fuses (one per phase).

\*\*\*\*\*

**WARNING**

Do not operate the Load Bank with any screen or cover removed. This may expose the operator to high voltage and rotating fan blades.

\*\*\*\*\*

## SECTION III

### INSTALLATION

#### BEFORE INSTALLATION

Inspect the Load Bank for obvious damage such as broken wires, broken or dented panels, cracked ceramic insulators, or any other component breakage that may have occurred in shipment.

#### LOCATION

The LPH100 is a portable Load Bank, and should be used in a cool, well-ventilated area. Cool air must be continually available and the hot exhaust air must be dissipated, not recirculated through the unit. Install the Load Bank so that the inlet and exhaust panels have unrestricted airflow clearance.

\*\*\*\*\*

#### CAUTION

Installation must prevent hot exhaust air from recirculating into the air intake. Inlet air temperatures exceeding 120°F may cause damage to the Load Bank. After installation, test the unit at full load and verify that the inlet air temperature does not exceed 120°F.

\*\*\*\*\*

#### AIRFLOW CONSIDERATIONS

Even with an ample supply of cooling air, the Load Bank may overheat if it is not properly installed. There are two types of airflow problems that should be avoided:

1. **Recirculating Airflow** - If the hot, exhausted air is permitted to recirculate through the Load Bank, it will reach such a high temperature and low density that it will no longer cool the resistance elements. A Load Bank should not be installed so close to any surface as to reflect the exhausted air back to the air intake. When two or more Load Banks are being used, care must be taken in positioning the Load Banks so that the exhausted air of one unit does not feed the air intake of another.
  
2. **Restriction of Cooling Air** - Any obstruction located within three (3) feet of the inlet and eight (8) feet of the exhaust screens will restrict the Load Bank's airflow. Airflow is also

restricted when two or more Load Banks have air inlets positioned too close to each other. This competition for cooling air causes a low pressure area, restricting adequate airflow.

\*\*\*\*\*

**W A R N I N G**

It is vitally important to install the Load Bank properly. Installation errors may result in a catastrophic failure. The overtemperature switches in the Load Bank will guard against some of these problems. If protective circuitry prevents application of the load, determine the source of the problem. **DO NOT DISABLE THE OVERTEMPERATURE SWITCHES.** This causes a safety hazard and voids our warranty. The following installation instructions are critical to the safe operation of the Load Bank. Refer to the **SAFETY CONSIDERATIONS** section of this manual.

\*\*\*\*\*

**POWER REQUIREMENTS**

The Load Bank requires a 120 volt, single phase, 60 Hz, 5 amp source of power for operation of the control circuit. A power cord for control power is provided with the Load Bank. Connect the power cord to a grounded 120 VAC source.

Load power is connected to the Load Bank through three receptacles on the side of the Load Bank labeled A, B, and C.

\*\*\*\*\*

**W A R N I N G**

Do not energize the Load Bank with the top cover removed.

\*\*\*\*\*

Cables to the Load Bank should be of adequate size to handle the maximum rated current according to the National Electric Code and any local codes. A ground connection is provided and must be connected to the frame of the power source, which in turn must be connected to a good earth ground. Loose connectors are provided to mate with the load receptacles.

\*\*\*\*\*

**CAUTION**

Make sure the top cover panel is securely fastened to the frame.

Never exceed the Load Bank rated voltage as this will cause the Load Bank to overheat.

\*\*\*\*\*

Lower voltages and different frequencies may be applied to the load circuit of the Load Bank. Frequency change causes no derating of the load; however, the applied kW with a lower voltage is computed by using the following formula:

$$kW_{Applied} = kW_{Rated} \times \frac{(Voltage Applied)^2}{(Voltage Rated)^2}$$

## SECTION IV

## OPERATION

### PURPOSE AND USE OF CONTROLS

1. POWER ON/OFF switch - Turns on the cooling fans and powers remainder of control circuit. CONTROL POWER light shows ON.
2. OVER TEMP indicator - This lamp should momentarily light when power switch is turned on. This shows the air safety circuit is working. The purpose of the OVER TEMP lamp is to warn the operator to remove the load from the Load Bank in case of improper cooling of the load elements.
3. MASTER LOAD ON/OFF switch - The MASTER LOAD switch connects power to all load steps, thus allowing all load steps which are actuated to load at the same time. It is also a master load disconnect.
4. KW LOAD STEPS switches - The load in kW is marked above each actuating switch. A load step may be turned ON or OFF before or during a test but will load the unit only when the MASTER LOAD switch is ON.
5. Digital Meter - Monitors load characteristics kW, V, A, Hz.
6. VOLTAGE SELECT switch - Configures load resistor circuit for 240V or 480V application.

### LOAD BANK OPERATION

All tests start with control panel switches in the OFF position.

\*\*\*\*\*

### CAUTION

Before energizing any load, verify that load voltage does not exceed rated voltage of load facility.

\*\*\*\*\*

The unit is energized by turning the POWER switch ON. This also energizes the cooling fans. Upon energizing the unit, the red OVER TEMP lamp will light momentarily. If, at any time,

there is insufficient cooling air to the elements, temperature switch(es) will disconnect the load and the red OVER TEMP lamp will light.

After the OVER TEMP lamp goes off, applying the appropriate switch will energize that load.

\*\*\*\*\*

**CAUTION**

Do not attempt operation if any fan is not running. Fan inlet and exhaust must be unrestricted. The operation of the fans is vital to the safe operation of this Load Bank. If OVER TEMP indicator light comes on and stays on for more than a few seconds without the load dropping out, shut off the power switch at once. Remove all power to the unit and check for proper operation of fan safety circuit. Failure to correct cooling air loss condition will result in destruction of the Load Bank. Refer to the SAFETY CONSIDERATIONS section of this manual.

\*\*\*\*\*

**OPERATING INSTRUCTIONS**

1. Place all switches on the control panel to the OFF position.
2. Connect a wire from the Load Bank frame ground stud to power source frame.
3. Connect power source frame to a good earth ground.
4. Connect appropriate power source leads to Load Bank.
5. Connect Load Bank to 120 volts, single phase, 60 Hz power source.
6. With POWER and MASTER LOAD switches in the OFF position, start the generator.
7. Position the load VOLTAGE SELECT 240/480 switch to the voltage to be applied.
8. Place the POWER switch in the ON position. Verify that the red OVER TEMP lamp momentarily lights. The CONTROL POWER lamp will light.
9. Position the KW LOAD STEPS switch(es) to the desired load.
10. Turn on the MASTER LOAD switch to apply desired load. Load steps may be added or deleted at any time.

11. Monitor load applied with digital meter (V, A, Hz, kW). Press and release the arrow up and arrow down buttons to change function being monitored.
12. After running tests, remove the load by turning off the MASTER LOAD switch.

After running a load test, residual heat may be removed from the Load Bank by allowing the blower to operate for a few minutes after load is removed. This procedure is not required for maintaining Load Bank integrity, but it may guard operating personnel from possible burn injuries.

\*\*\*\*\*

**W A R N I N G**

DO NOT touch the exhaust screen during operation. The screen will become hot from the exhausted heat and may cause a serious burn. Refer to the SAFETY CONSIDERATIONS section of this manual.

DO NOT allow objects to enter or block screens.

\*\*\*\*\*

13. Place the POWER switch to the OFF position.
14. Shut down all power sources to the Load Bank.
15. Disconnect the power source cables and the ground connection from the Load Bank.
16. Disconnect the 120V source to the Load Bank.

**SINGLE PHASE LOAD BANK OPERATION**

The LPH100 Load Bank can be used to test single phase AC sources.

- A. For 240 volt, single phase operation up to 46.9 kW, connect to Load Bank as shown below.

**NOTE**

**Place VOLTAGE SELECT switch in the 240V mode.**

\*\*\*\*\*

**WARNING**

"C" bus and any attached wiring are electrically hot when operating Load Bank in single phase, per Figure 1.

\*\*\*\*\*

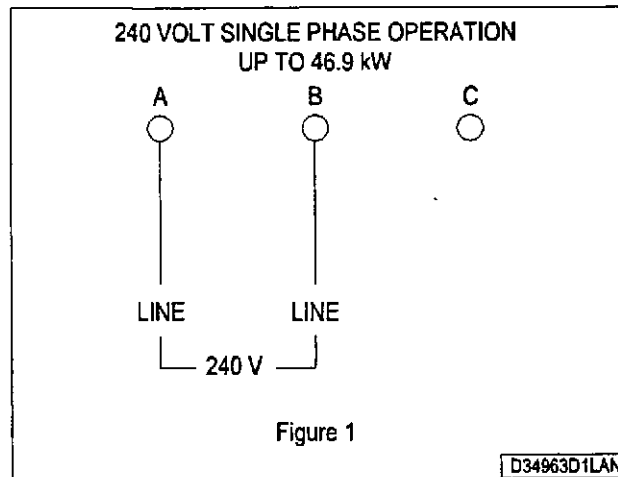

**Load Step Rating:**

| <u>3-Phase (240V)</u> | <u>1-Phase (240V)</u> |
|-----------------------|-----------------------|
| 3.75 kW               | 1.875 kW              |
| 7.5 kW                | 3.75 kW               |
| 7.5 kW                | 3.75 kW               |
| 25 kW                 | 12.5 kW               |
| 50 kW                 | 25 kW                 |

- B. For 240 volt single phase operation up to 62.75 kW, connect to Load Bank as shown below.

**NOTE**

Place **VOLTAGE SELECT** switch in the **240V** mode.

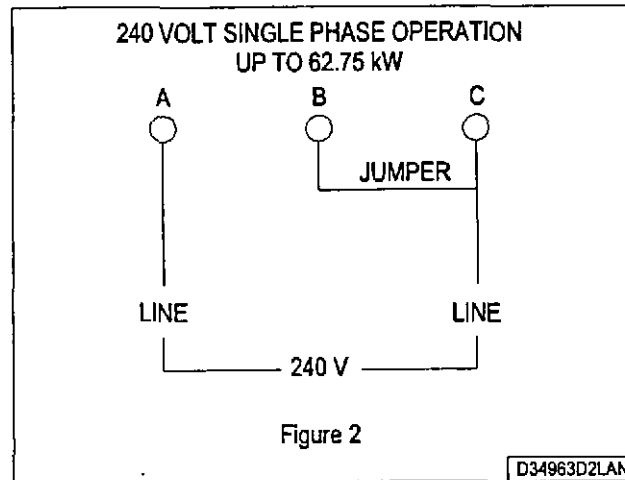

Load Step Rating:

| <u>3-Phase (240V)</u> | <u>1-Phase (240V)</u> |
|-----------------------|-----------------------|
| 3.75 kW               | 2.5 kW                |
| 7.5 kW                | 5.0 kW                |
| 7.5 kW                | 5.0 kW                |
| 25 kW                 | 16.75 kW              |
| 50 kW                 | 33.5 kW               |

Lower voltages and different frequencies may be applied to the load circuit of the Load Bank. Frequency change causes no derating of the load; however, the applied kW with a lower voltage is computed by using the following formula:

$$kW_{Applied} = kW_{Rated} \times \frac{(Voltage Applied)^2}{(Voltage Rated)^2}$$



## ESD PRECAUTIONARY GUIDELINES

### CAUTION

Certain circuit card assemblies and their components, typically integrated circuits, may be damaged by seemingly undetectable electrostatic discharge (ESD). Care must be exercised during handling/repair of these items. Use electrostatic discharge precautionary procedures.

The following guidelines are not necessarily all inclusive but rather serve as reminders for good shop practices for the handling/repair of ESD sensitive circuit card assemblies and devices.

- Store ESD sensitive items in their original containers. These items are often marked with the symbol shown at the top of this page.
- Put on a grounded wrist strap before handling any ESD sensitive item.
- Clear work area of Styrofoam®, plastic, and vinyl items such as coffee cups.
- Handle ESD items by the body, never the open edge connectors.
- Never slide ESD sensitive items over any surface.
- Transport ESD sensitive items in a static shielding container to a static-free work station.
- If a static-free work station is not available, ground the transport container before removing or inserting an ESD item.
- Electric tools used during repair should be grounded. For example, use only anti-static type solder suckers and grounded tip soldering irons. Discharge non-electric tools before use.
- Pack ESD items in static shielding containers before shipping them to Avtron for repair.

\* Styrofoam® is a registered trademark of Dow Chemical.

## SECTION V

### MAINTENANCE

To provide long equipment life and to reduce the chance of electric shock, fires, and personal injury, good maintenance procedures must be used. Before servicing, review the SAFETY CONSIDERATIONS section of this manual.

The following examples of scheduled maintenance procedures are not purported to be all-inclusive, but must be accomplished to maintain the equipment in a good, safe condition. All maintenance work must be done only by qualified personnel.

\*\*\*\*\*

#### WARNING

Personal injury from electrical shock or from the moving fan blade may result if ALL sources of power are not disconnected. Refer to the SAFETY CONSIDERATIONS section of this manual.

\*\*\*\*\*

#### DAILY

1. Remove any restrictions to airflow through the Load Bank.
2. Check the screens to make sure that no objects have blocked or entered the openings.
3. Verify that the airflow is in the proper direction.
4. Assure that there is no recirculation of the exhaust air through the Load Bank.

**THREE MONTHS OR 500 HOURS**

1. Remove access panels and screens.
2. Inspect the load resistors for mechanical breakdown which is demonstrated by excessive sagging of the elements. Replace with new resistor elements as required.
3. Inspect for broken ceramic insulators. Replace with a new ceramic insulator if any cracks are found.
4. Inspect for loose hardware or loose connections. Tighten where required.
5. Inspect all connections for oxidation or corrosion. Clean the connection or replace the hardware where required.
6. Inspect all magnetic contactors to make sure that the contacts are not severely pitted or corroded. The contacts must move freely and be properly seated.
7. Clean all dirt and debris out of the Load Bank. This can be accomplished by blowing the inside of the unit with clean, dry compressed air (not to exceed 40 PSI). Eye protection should be worn when cleaning the Load Bank with compressed air.
8. Inspect all the wiring for any sign of insulation failure.
9. Replace all access panels and screens. Tighten all the fastening hardware securely.
10. Check the indicator lamps on the control panel.

**PARTS REPLACEMENT**

Access to any component is easily made with the removal of the cover panels. Replaceable components in the unit are listed in the replacement parts list. Avtron maintains an inventory of normally used items.

## SECTION VI

# REPLACEMENT PARTS LIST

### INTRODUCTION

The parts list in this section contains the description, quantity required, and Avtron part numbers for each listed part. The list also includes, where appropriate, the manufacturer's name and part number, as well as schematic reference designators to facilitate parts identification.

#### NOTE

Every effort has been made to ensure the accuracy of this information. However, changes are sometimes necessary and revisions to the parts list may be made at any time without notice.

### REFERENCE DESIGNATORS

Service personnel may use this parts list along with the Avtron system schematics to identify and order replaceable parts. The reference designators were carefully selected and matched to those on the schematic diagrams and equipment to simplify the troubleshooting and repair process.

#### NOTE

When ordering replacement parts, be certain to state the part's description and Avtron part number, and the schematic reference designator number if one is available. Also include the model and serial number of the equipment.

## REPLACEMENT PARTS LIST

| SCHEMATIC REFERENCE | DESCRIPTION  | MANUFACTURER and PART NO.                       | AVTRON P/N                            | QTY/UNIT |
|---------------------|--|---|---------------------------------------|----------|
| XW1-3               | AVTRON MODEL LPH100<br>LOAD BANK, PORTABLE, INDOOR<br>.SCHEMATIC<br>.COVER, CONNECTOR, SNAP BACK | ADVANCED DEVICES<br>CL40WTC-L-125-A             | LPH100-<br>D34963<br>D34965<br>428375 | REF<br>3 |
| K6, K7, K8          | .RELAY   |   | B14795                                | 3        |
| K9, K10             | .RELAY   |   | B14796                                | 2        |
| R100                | .RESISTOR, 100K, 1/2W, 10%   | RCR20G104KS                                     | 110048                                | 1        |
|                     | .CONNECTOR, RECEPTACLE   | HUBBELL<br>1547                                 | 313832                                | 1        |
| P1                  | .CONNECTOR, RECEPTACLE   | HUBBELL<br>HBL5278C                             | 314431                                | 1        |
| B1-B4               | .FAN   | EBM INDUSTRIES<br>W2E200-HH86-01                | 322186                                | 4        |
| B5                  | .FAN   | DAYTON ELECTRIC<br>4WT40                        | 322212                                | 1        |
| F103                | .FUSE, 5A, 600V  | LITTELFUSE<br>KLDL-5                            | 324475                                | 1        |
| XF103               | .FUSEHOLDER  | BUSSMANN<br>HPS-RR                              | 324985                                | 1        |
| F1, F2, F3          | .FUSE, 300A  | LITTELFUSE<br>JJLS-300                          | 324386                                | 3        |
| F100-F102           | .FUSE, 1A  | LITTELFUSE<br>KLDL-1                            | 324449                                | 3        |
| XF100-XF102         | .FUSEBLOCK   | BUSSMANN COOPER<br>BC6033SQ                     | 324998                                | 1        |
| DS1                 | .LAMP, INDICATOR   | DIALIGHT<br>249-7841-1433-574                   | 329681                                | 1        |
| DS2                 | .LAMP, INDICATOR   | DILAIGHT<br>249-7841-1431-574                   | 329682                                | 1        |
| M1                  | .METER   | MULTITEK<br>M801-MD4-VE                         | 336992                                | 1        |
| K100, K101          | .RELAY   | POTTER & BRUMFIELD<br>T92S11A22-120             | 350539                                | 2        |
| K480                | .RELAY, VOLT SENSE   | CROUZET<br>84-893-106                           | 351653                                | 1        |
| K1-K5               | .RELAY   | DELTROL<br>21009-84-375TM-<br>3PST-NO-3A-120VAC | 350982                                | 5        |
| S60-S63             | .SWITCH, TEMP  | SELCO<br>SE-L250                                | 491021                                | 4        |
| S1, S3-S8           | .SWITCH, TOGGLE  | CARLINGSWITCH<br>2GK51-73                       | 360589                                | 7        |
| S2                  | .SWITCH, TOGGLE  | EATON<br>7992K10                                | 360747                                | 1        |
| CT1, CT2            | .TRANSFORMER, CURRENT  | INSTRUMENT<br>TRANSFORMERS<br>AL-251            | 371220                                | 2        |
|                     | .CASTER  | W. W. GRAINGER<br>3A001                         | 417074                                | 4        |

# APPENDIX

## LOAD BANK TROUBLESHOOTING GUIDE

### NOTE

Servicing should always be done only by trained, qualified service technicians.

\*\*\*\*\*

### W A R N I N G

Be sure that all sources of power to the Load Bank are disconnected before servicing.

\*\*\*\*\*

| PROBLEM                                   | POSSIBLE CAUSES/REMEDIES  |
|---|---|
| 1. Load Bank main power fails to come on. | a. Main switch or circuit breaker is not closed.<br>b. Unit is not connected according to the Schematic/Interconnection Diagram.<br>c. Terminals were damaged during shipment.<br>d. Fuses are blown. (Check and replace as required.)*<br>e. Fuse is blown in Load Bank control circuit. (Check and replace as required.)*<br>f. Dirty or loose connection at Main Power Switch. |
| 2. Blower motor does not operate.         | a. Main switch or circuit breaker is not closed.<br>b. Power is not connected to Load Bank blower circuit.<br>c. External power source is inadequate.<br>d. Motor fuses are blown. (Check and replace as required.)*  |

\* When checking fuses for continuity, be sure to remove all fuses from clips (in fuseblock or Disconnect Switch). Test each fuse individually, out of circuit. (If tested in circuit, there is the possibility of feedback which causes false readings. A blown fuse may still check out OK.)

| PROBLEM  | POSSIBLE CAUSES/REMEDIES   |
|--|--|
| 2. Blower motor does not operate.<br>(Cont.)                 | <ul style="list-style-type: none"> <li>e. Motor overload is tripped.</li> <li>f. Motor start is malfunctioning.</li> <li>g. Main Power Switch is inoperative.</li> <li>h. Connections are broken or loose.</li> <li>i. Motor shaft does not turn due to improper lubrication. (Replace or repair as necessary.)</li> </ul>   |
| 3. BLOWER FAILURE indicator lights, yet blower is operating. | <ul style="list-style-type: none"> <li>a. Airflow restrictions present at Load Bank intake or exhaust.</li> <li>b. Improper fan blade rotation or phase reversal. (Check fan motor power connections for proper phase sequence.)</li> <li>c. Air Differential Pressure Switch is malfunctioning.</li> <li>d. Blower Fail Relay is malfunctioning.</li> </ul>   |
| 4. Fan blade is broken or not turning.                       | <ul style="list-style-type: none"> <li>a. Fan blade motion is obstructed.</li> <li>b. Fan blade is loose at hub or is not keyed properly.</li> </ul>   |
| 5. Load step(s) cannot be energized.                         | <ul style="list-style-type: none"> <li>a. A blower failure exists. (See problem 2.)</li> <li>b. MASTER LOAD Switch is inoperative.</li> <li>c. Control power is inadequate.</li> <li>d. Fuse is blown in Load Bank control circuit or individual branch circuit load fuse (if so equipped) is blown. (Check and replace as required.)*</li> <li>e. Blower Fail Relay is malfunctioning.</li> <li>f. Load step switch is inoperative.</li> <li>g. Load step contactor is inoperative.</li> <li>h. Magnetic contactor has an open coil.</li> <li>i. Load step resistor is open.</li> </ul> |

\* When checking fuses for continuity, be sure to remove all fuses from clips (in fuseblock or Disconnect Switch). Test each fuse individually, out of circuit. (If tested in circuit, there is the possibility of feedback which causes false readings. A blown fuse may still check out OK.)

| PROBLEM   | POSSIBLE CAUSES/REMEDIES   |
|---|--|
| 6. Contactor "chattering" exists.                   | <ul style="list-style-type: none"> <li>a. Contacts and/or core are dirty or corroded.</li> <li>b. Connections to contactor coil are loose.</li> <li>c. Control circuit line voltage is too low.</li> </ul>   |
| 7. Load Bank or load step does not give rated load. | <ul style="list-style-type: none"> <li>a. Applied load voltage is either derated or inadequate.</li> <li>b. Contactor does not close properly.</li> <li>c. Load step resistor element is open.</li> <li>d. One of the individual load branch circuit fuses is blown (if so equipped).</li> </ul> |
| 8. Disconnect Switch fuses are blown.               | <ul style="list-style-type: none"> <li>a. Fuses are undersized.*</li> <li>b. A short circuit exists in the blower or control circuit.*</li> </ul>  |

\* When checking fuses for continuity, be sure to remove all fuses from clips (in fuseblock or Disconnect Switch). Test each fuse individually, out of circuit. (If tested in circuit, there is the possibility of feedback which causes false readings. A blown fuse may still check out OK.)

# DRAWINGS

## PROPRIETARY NOTE

The wiring diagrams and schematics which follow contain information PROPRIETARY to Avtron Manufacturing, Inc.; are furnished solely to provide information sufficient for instruction, operation, maintenance, evaluation, and testing of the equipment herein disclosed; are not to be used for manufacturing or procurement; and are not to be disclosed to anyone other than persons in the Division, or the Company, or the Government, as the case may be, responsible for action relating to this document without the express written permission of Avtron Manufacturing, Inc.

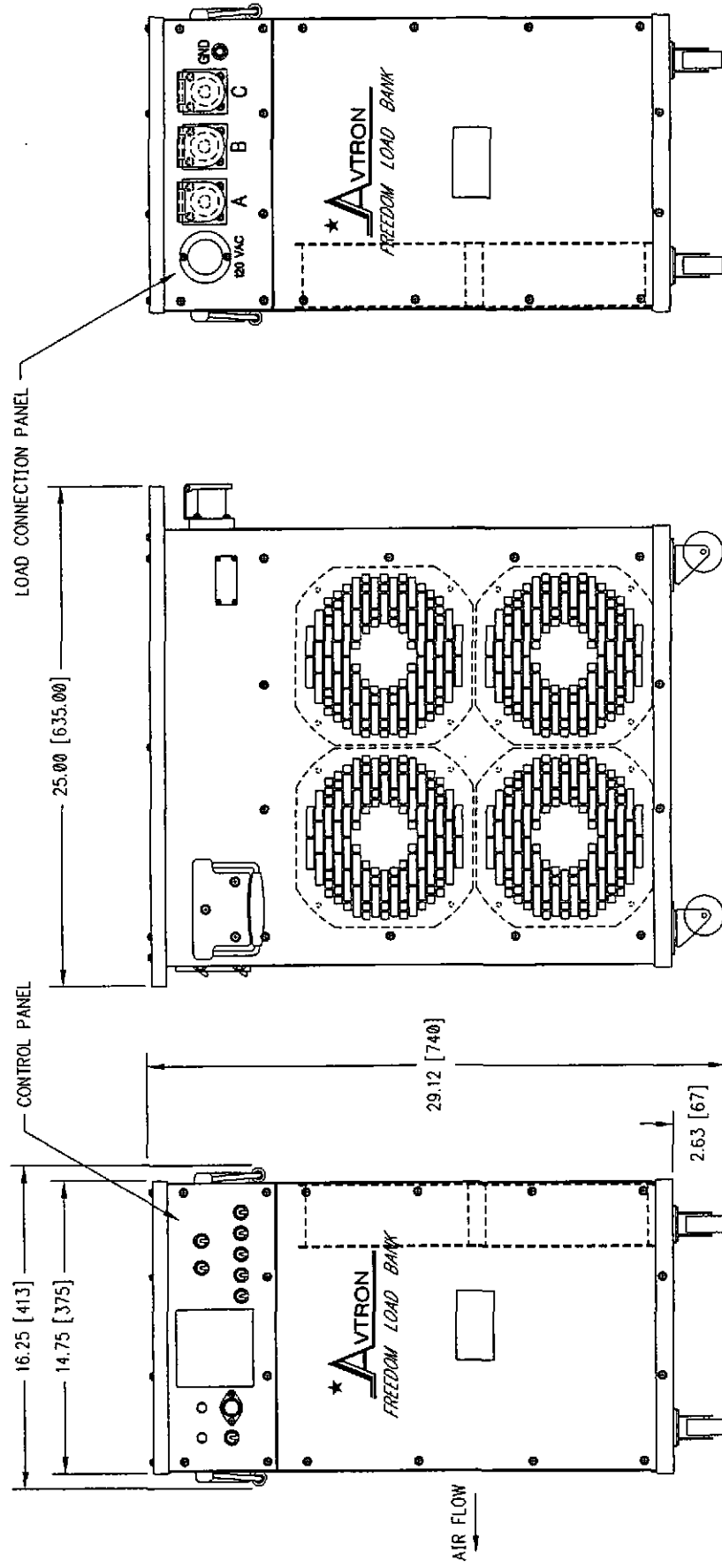

FOR APPLICATION ENGINEERING USAGE ONLY

|          |  |           |                   |             |                    |  |                                |
|----------|--|-----------|-------------------|-------------|--------------------|--|--------------------------------|
| DRAWN    |  | J. FLAUTO | DATE              | 10/18/01    | DRAWING NUMBER     |  | SB3192                         |
| CHECKED  |  | J. FLAUTO | DATE              | 1/3/02      | MANUFACTURER, INC. |  | AVTRON                         |
| APPROVED |  | J. HUDSON | DATE              | 3/16        | TYPE, OR           |  | LOAD BANK, PORTABLE,<br>INDOOR |
| REV      |  | NO.       | DESCRIPTION       | DATE        | BY                 |  |                                |
| B        |  | 1         | REV PER EON       | 12/5/05     | HUDSON             |  |                                |
| A        |  | 1         | WEIGHT WAS 18 LBS | 6/24/02     | HUDSON             |  |                                |
| EON      |  | REV       | NO.               | DESCRIPTION | DATE               |  |                                |
| 1        |  | 1         | CHANGE            |             |                    |  |                                |

THIS DOCUMENT CONTAINS PROPRIETARY INFORMATION OF AVTRON MFG., INC. AND MAY NOT BE DISCLOSED TO OTHERS OR USED FOR MANUFACTURING PURPOSES WITHOUT THE WRITTEN CONSENT OF AVTRON MFG.

3. UNIT IS SUPPLIED WITH A 15 FT. [4.7 M], 120 V LINE CORD (NOT SHOWN).  
 2. ALL DIMENSIONS ARE APPROX. INCH [METRIC].  
 1. WEIGHT: 105 LBS. [48 KG] APPROX
- NOTES:

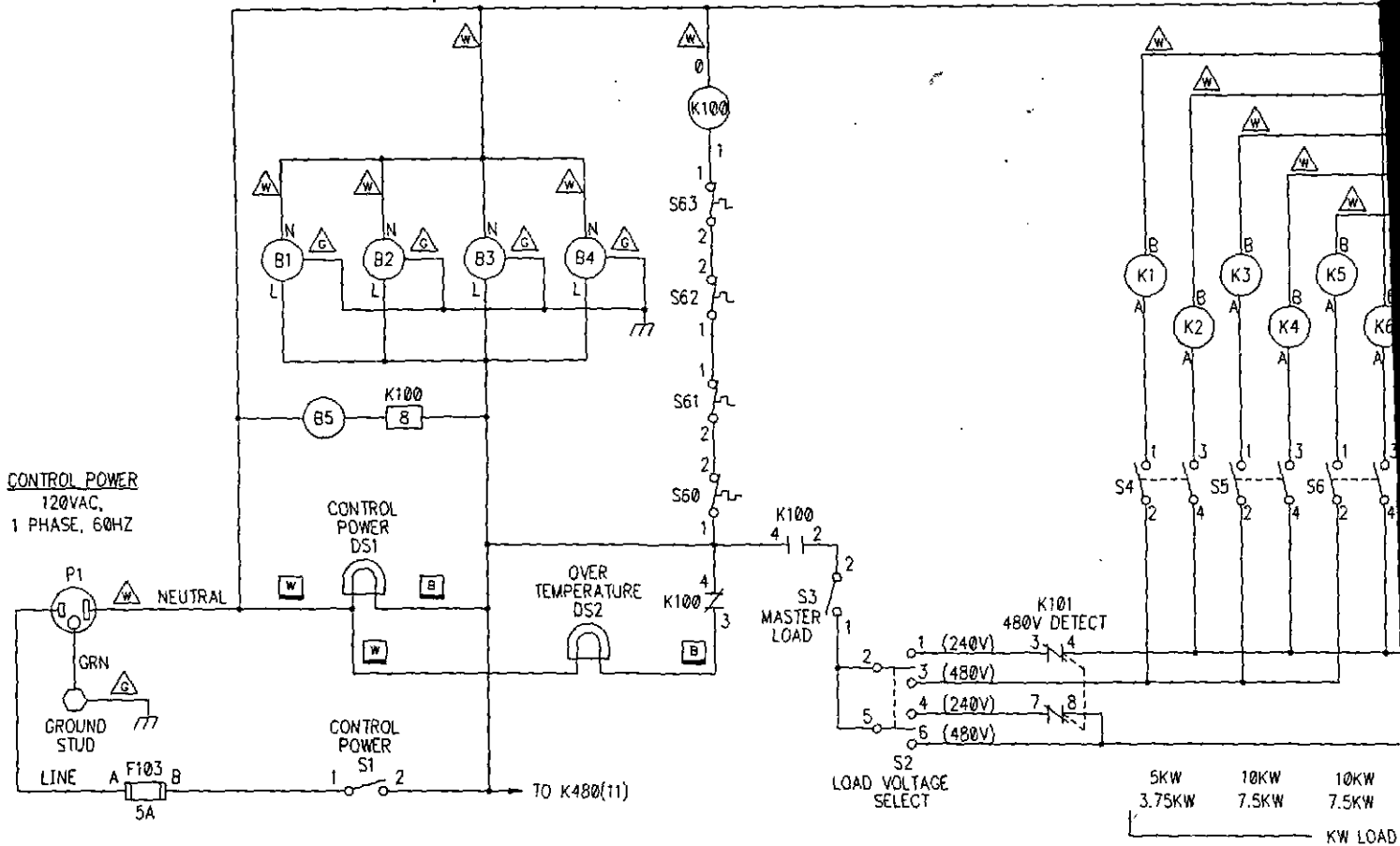

**CONTROL POWER**  
120VAC,  
1 PHASE, 60HZ

**CONTROL POWER DS1**

**OVER TEMPERATURE DS2**

**CONTROL POWER S1**

**S3 MASTER LOAD**

**K101 480V DETECT**

**S2 LOAD VOLTAGE SELECT**

**5KW 10KW 10KW 3.75KW 7.5KW 7.5KW KW LOAD**

- 4- PRESET VOLTAGE SENSE RELAY (K480) TO 270V BUS VOLTS, 0% HYS.
- 3- WIRE LEGEND: (WIRE CODE TYPICAL FOR ALL SHEETS)  
ALL UNMARKED WIRE TO BE BLACK #18 AWG (P/N 390005)
- Ⓛ INDICATES WIRE TO BE BLACK #16 AWG (PN 390008)
- Ⓜ INDICATES WIRE TO BE WHITE #18 AWG (PN 390005)
- Ⓝ INDICATES WIRE TO BE GREEN #18 AWG (PN 390005)
- Ⓟ INDICATES WIRE TO BE BLACK #14 AWG (PN 390011)
- Ⓠ INDICATES WIRE TO BE BLACK #8 AWG (PN 390019)
- Ⓡ INDICATES WIRE TO BE BLACK #6 AWG (PN 390020)
- Ⓢ INDICATES WIRE TO BE BLACK #1/0 AWG (PN 390025)
- Ⓣ INDICATES WIRE TO BE BLACK #22 AWG (PN 390001)
- Ⓤ INDICATES WIRE TO BE WHITE #22 AWG (PN 390001)
- 2- DO NOT RUN POWER WIRING IN THE SAME BUNDLE AS CONTROL PANEL WIRING.
- 1- CT1 & CT2 LEADS SHOULD BE THE SAME LENGTH.

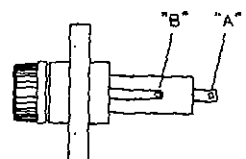

**FUSE F103**  
**TERMINAL LOCATIONS**

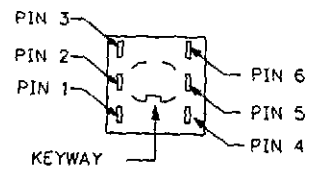

**SWITCH S2**  
**TYPICAL TERMINAL LOCATIONS**

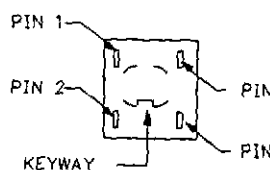

**SWITCHES S1, S3-S8**  
**TYPICAL TERMINAL LOCATIONS**

| ECN NO. | REV | REVISIONS   |      |          |
|---------|-----|-------------|------|----------|
|         |     | DESCRIPTION | DATE | APPROVED |
|         |     |             |      |          |

**CUSTOMER LOAD CONNECTION**  
 100KW @ 240VAC (120A)  
 93.75KW @ 240VAC (120A)  
 70.4KW @ 208VAC (195A)  
 3 PHASE, 60HZ

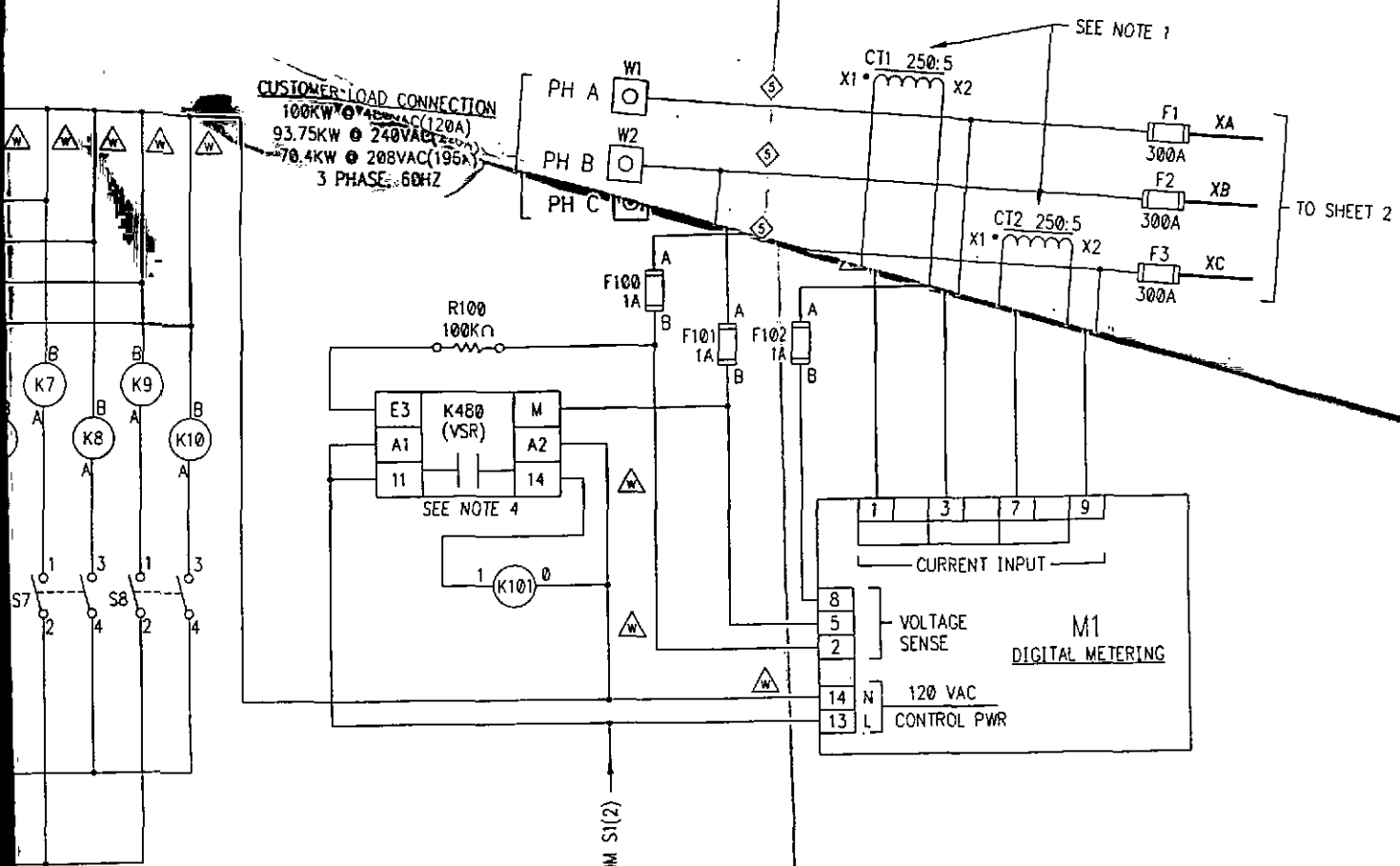

25KW 50KW @ 480V  
 25KW 50KW @ 240V

STEPS

|   |   |   |                          |  |              |
|---|---|---|--------------------------|--|--------------|
| THIS DOCUMENT CONTAINS PROPRIETARY INFORMATION OF AVTRON MFG., INC. AND MAY NOT BE DISCLOSED TO OTHERS OR USED FOR MANUFACTURING PURPOSES | UNLESS OTHERWISE SPECIFIED DIMENSIONS ARE IN INCHES | DRAWN FACKELMANN                                    | DATE 5/12/03             | 7980 E.PLEASANT VALLEY ROAD<br>INDEPENDENCE, OH 44131-5529<br><b>AVTRON MANUFACTURING INC</b>                      |              |
|   | TOLERANCES: DECIMALS .XXX                           | ANGLES ±1° .XXX                                     | CHECKED J.FLAUTO         |  | 5/12/03      |
|   | FINISH  | PAINT PER PS  | ENG. APPROV. D.KOZAR     |  | 5/13/03      |
|   | PLATE PER   | COAT PER PS   | APPROV. PROD. A.VYSOTSKY |  | 5/13/03      |
|   | ANODIZED PER  |   |                          |  |              |
| LPH100 D34963   | LPH100 D34963                                       | <b>SCHEMATIC/INTERCONNECTION DIAGRAM, LOAD BANK</b> |                          | <input checked="" type="checkbox"/> IMF<br><input checked="" type="checkbox"/> PSF<br><input type="checkbox"/> REV |              |
| NEXT ASSY   | USED ON   | SIZE D  | CAGE NO. 01014           | DWG. NO. D34965  |              |
|   |   |   |                          |  | SHEET 1 OF 2 |

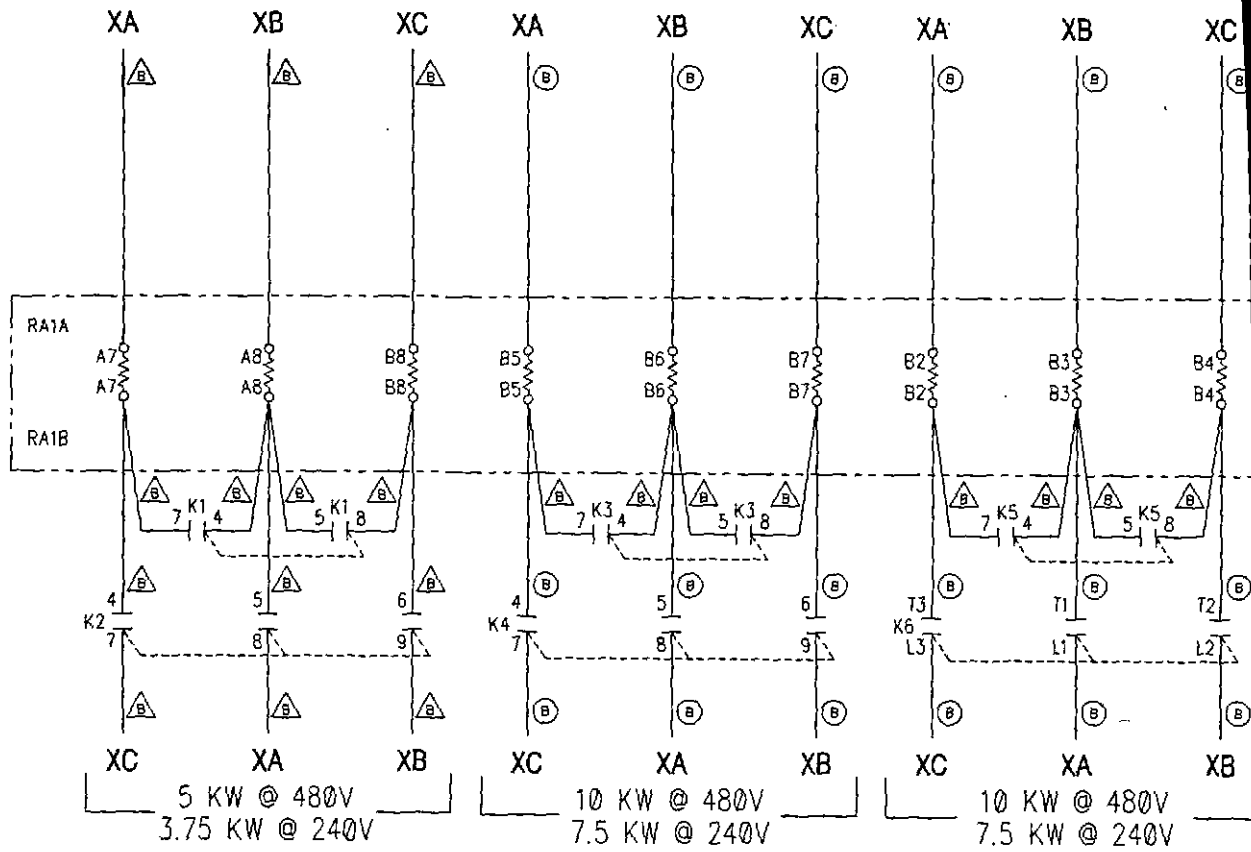

SEE SHEET 1 FOR WIRE CODE AND NOTES.

UNLESS OTHERWISE SPECIFIED THE ABOVE NOTES APPLY

| ECH NO | REV | REVISIONS   |      |          |
|--------|-----|-------------|------|----------|
|        |     | DESCRIPTION | DATE | APPROVED |
|        |     |             |      |          |

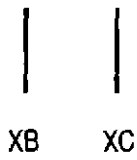
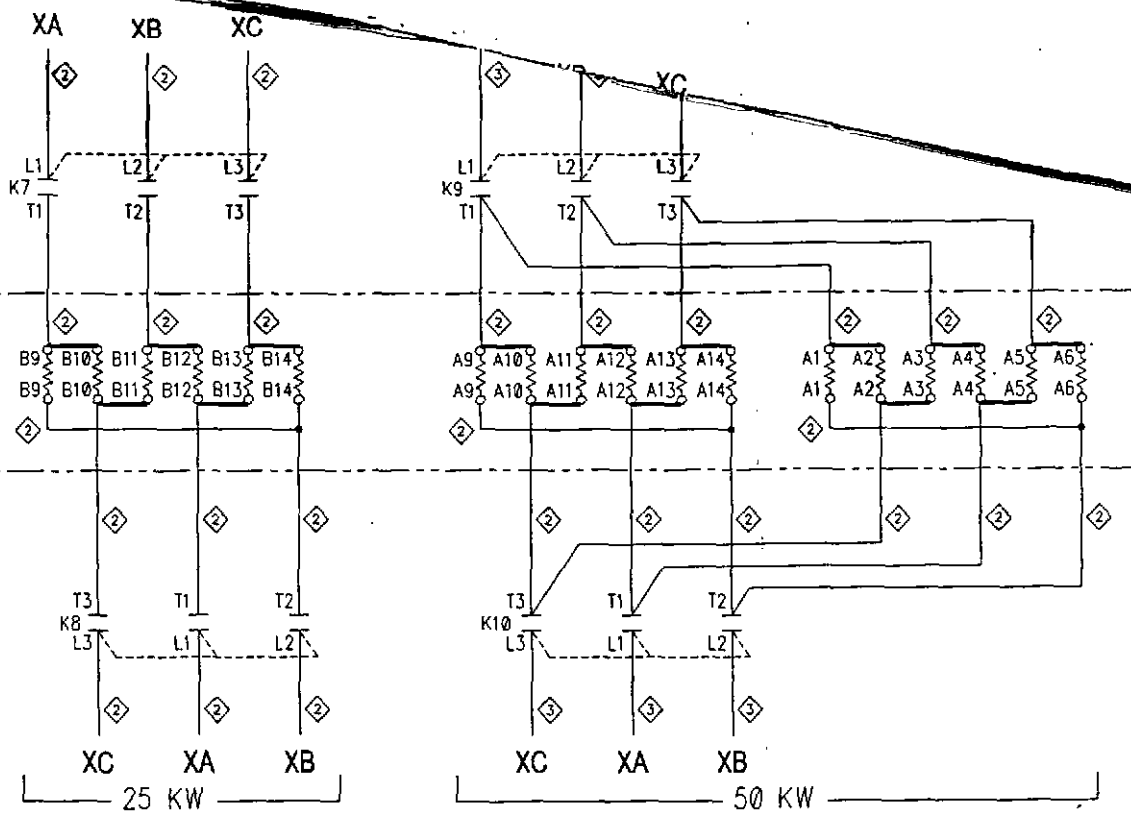

FROM SHEET 1

|   |   |                          |                                  |     |
|---|---|--------------------------|----------------------------------|-----|
| <br><small>7900 E. PLEASANT VALLEY ROAD<br/>INDEPENDENCE, OH 44131-5529</small> | SCHEMATIC/INTERCONNECTION<br>DIAGRAM, LOAD BANK   |                          |                                  | REV |
|   | <small>THIS DOCUMENT CONTAINS PROPRIETARY INFORMATION<br/>OF AVTRON MFG., INC. AND MAY NOT BE DISCLOSED</small> | <small>SIZE</small><br>D | <small>CAGE NO.</small><br>01014 |     |

| REVISIONS |             | DATE | APPROVED |
|-----------|-------------|------|----------|
| ECN NO.   | LTR         |      |          |
|           | DESCRIPTION |      |          |

**QTY 3 CABLES REQUIRED**

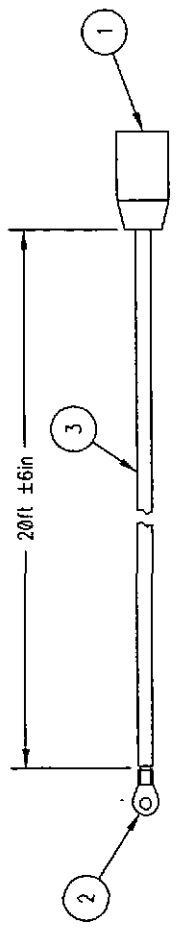

**QTY 1 CABLE REQUIRED**

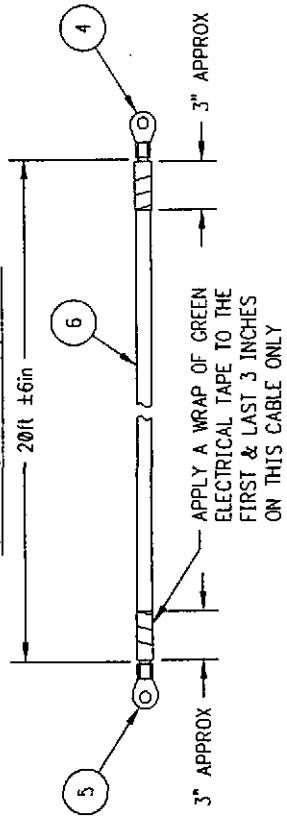

| ITEM NO. | NO. RECD | PART NO. | DESCRIPTION                        | MATERIAL |
|----------|----------|----------|------------------------------------|----------|
| 6        | 20' 6"   | 390022   | WIRE, ELECT, #2 AWG                |          |
| 5        | 1        | 366043   | TERMINAL, LUG, #2 AWG, 1/2 SCREW   |          |
| 4        | 1        | 366041   | TERMINAL, LUG, #2 AWG, 3/8 SCREW   |          |
| 3        | 61' 6"   | 390026   | WIRE, ELECT, #2/0 AWG              |          |
| 2        | 3        | 366053   | TERMINAL, LUG, #2/0 AWG, 1/2 SCREW |          |
| 1        | 3        | 315001   | CONNECTOR, PLUG,(FEMALE)           |          |

**LIST OF MATERIAL**

|   |             |            |         |        |
|---|-------------|------------|---------|--------|
| UNLESS OTHERWISE SPECIFIED DIMENSIONS ARE IN INCHES | DRAWN       | J.FLAUITO  | DATE    | 1/4/02 |
| TOLERANCES: .XXX± .015                              | CHECKED     | J.FLAUITO  | 1-7-02  |        |
| ANGLES±.1 .XXX± .03                                 | ENG APP'D   | J.HUDSON   | 1-7-02  |        |
| FINISH  | APPT' PRO'D | A.VYSOTSKY | 1/8/02  |        |
| PAINT PER PS  | S. O. NO.   |            | NO RECD |        |
| ZINC PLATE PER                                      |             |            |         |        |
| COAT PER PS   |             |            |         |        |
| ANODIZE PER   |             |            |         |        |
| OTHER   |             |            |         |        |

**AVTRON** MANUFACTURING, INC.  
 7800 E. PLEASANT VALLEY ROAD  
 INDEPENDENCE, OH 44131-5529

CABLE SET-20 FT (OPTION 1)

SIZE: **B**    CASE NO.: **01014**    DRAWING NO.: **B28571**

SCALE: **1/1**    MODEL: **LPH 105**    SHEET **1** OF **1**

- REF: THIS CABLE SET IS FOR USE WITH THE LPH 105 LOAD BANK.
  - PACKAGE ALL 4 CABLES TOGETHER AND PART MARK .12 MIN HIGH ON OUTSIDE OF PACKAGE.
- UNLESS OTHERWISE SPECIFIED THE ABOVE NOTES APPLY.

THIS DOCUMENT CONTAINS PROPRIETARY INFORMATION OF AVTRON MFG. INC. AND MAY NOT BE DISCLOSED TO OTHERS OR USED FOR REPRODUCTION WITHOUT THE WRITTEN CONSENT OF AVTRON MFG.

6. RELAY TERMINAL REFERENCE DESIGNATORS ARE FOR SCHEMATIC REFERENCE. THESE REFERENCES SUPERSEDE ANY MARKINGS THAT MAY APPEAR ON THE RELAY TERMINAL COVERS.
5. WHEN WIRING FANS "B1-B4", RUN A SINGLE WHITE, BLACK, AND GREEN CONDUCTOR FROM THE FAN ASSEMBLY TO THE CONTROL CIRCUIT. LEAVE A SERVICE LOOP SUCH THAT PANEL (ITEM 4) CAN BE REMOVED AND FANS ACCESSED. USE CABLE CLAMPS 422008 & 422009 AS NECESSARY TO SECURE WIRE TO FANS.
4. STACK WIRES UNDER FUSE WITH LARGER WIRES CLOSER TO FUSE.
3. INK STAMP OR LABEL TEMPERATURE SWITCH DESIGNATIONS "S60-S63" AS SHOWN.
2. ALL EXTERIOR HARDWARE TO BE STAINLESS STEEL.
1. MARK REFERENCE DESIGNATORS .12 HIGH MINIMUM USING PRODUCTION DECALS AND OR INK STAMPING. SPRAY OVER INK STAMPING WITH CLEAR ACRYLIC LACQUER. REFERENCE DESIGNATORS SHALL BE LOCATED ADJACENT TO COMPONENTS SO THAT THEY REMAIN VISIBLE AFTER WIRING.

UNLESS OTHERWISE SPECIFIED THE ABOVE NOTES APPLY

| REVISIONS |     |   |          |            |
|-----------|-----|---|----------|------------|
| ECN NO.   | REV | DESCRIPTION   | DATE     | APPROVED   |
| CD410     | A   | REVISED SHEET 3 PER ECN FACKELMANN                                    | 6/30/03  | J. HUDSON  |
| CD698     | B   | REVISED NOTE 3 PER ECN. SEE SH 2 & 3. J.FLAUTO                        | 5-17-04  | J. HUDSON  |
| AN830     | C   | ITEM 31 WAS 660135 HARFORD  | 8/12/04  | J.PALINKAS |
| CD809     | D   | ADD "240/480V" TO TITLE BLK; REV SHTS 2&3 MJ                          | 10/01/04 | J. HUDSON  |
| CE211     | E   | ADDED ITEM 15, ITEM 44 WAS 324615, FACKELMANN REVISED SHEET 3 PER ECN | 12/5/05  | J. HUDSON  |

|    |          |                             |               |
|----|----------|-----------------------------|---------------|
| 5  | 350982   | RELAY                       |               |
| 1  | 351653   | RELAY, VOLT SENSE           |               |
| 2  | 350539   | RELAY                       |               |
| 1  | 336992   | METER                       |               |
| 1  | 329682   | LAMP, INDICATOR             |               |
| 1  | 329681   | LAMP, INDICATOR             |               |
| 1  | 324998   | FUSEBLOCK                   |               |
| 3  | 324449   | FUSE, 1A                    |               |
| 3  | 324386   | FUSE, 300A                  |               |
| 1  | 324985   | FUSEHOLDER                  |               |
| 1  | 324475   | FUSE, 5A, 600V              |               |
| 1  | 322212   | FAN                         |               |
| 4  | 322186   | FAN                         |               |
| 3  | 315001   | CONNECTOR, FEMALE           | SHIPPED LOOSE |
| 3  | 314900   | CONNECTOR, MALE STUD        |               |
| 1  | 314431   | CONNECTOR, RECEPTACLE       |               |
| 1  | 390019   | CABLE ASSY, LINE CORD       | SHIPPED LOOSE |
| 1  | 313832   | CONNECTOR, RECEPTACLE       | SHIPPED LOOSE |
| 1  | 110048   | RESISTOR, 100K, 1/2W        |               |
| 6  | 510011   | STUD, 3/8-16 X 2.50         |               |
| 15 | A17912   | BUS BAR                     |               |
| 54 | A21179   | BUSHING, SUPPORT ROD        |               |
| 1  | A29405   | PLATE, IDENTIFICATION       |               |
| 27 | A27897   | SUPPORT ROD, ELEMENT        |               |
| 18 | A27896-6 | RESISTANCE ELEMENT (25 KW)  |               |
| 6  | A27896-5 | RESISTANCE ELEMENT (10 KW)  |               |
| 3  | A27896-1 | RESISTANCE ELEMENT (5 KW)   |               |
| 2  | B15905   | LABEL, INSTRUCTION, WARNING |               |
| 2  | B15896   | LABEL, INSTRUCTION, WARNING |               |
| 1  | B15871   | PLATE, INSTRUCTION, WARNING |               |
| 2  | B14796   | RELAY                       |               |
| 3  | B14795   | RELAY                       |               |
| 3  | 428375   | SNAP BACK COVER             |               |
| 1  | C25804   | PANEL, CONTROL              |               |
| 1  | C25303   | PANEL, CONNECTION           |               |
| 2  | C25302   | PANEL, ACCESS               |               |
| 1  | C25301   | SUPPORT, COMPONENT          |               |
| 1  | C25300   | HEAT SHIELD                 |               |
| 1  | D33080   | HEAT SHIELD, FAN            |               |
| 1  | D34965   | SCHEMATIC                   |               |
| 1  | D32803   | COVER, TOP                  |               |
| 1  | D32802   | PANEL, EXHAUST              |               |
| 1  | D32801   | PANEL, INTAKE               |               |
| 1  | D32800-2 | SUPPORT, ELEMENT            |               |
| 1  | D32800-1 | SUPPORT, ELEMENT            |               |
| 1  | D32799   | BASE, LOAD BANK             |               |

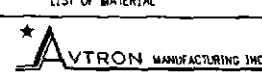
| NO. RECD         | PART NO. | DESCRIPTION  | MATERIAL     |
|------------------|----------|--|--------------|
| LIST OF MATERIAL |          |  |              |
| DATE             | DATE     | <br>7900 E. PLEASANT VALLEY ROAD<br>INDEPENDENCE, OH 44131-5529 |              |
| FACKELMANN       | 5/12/03  |  |              |
| J.FLAUTO         | 5/12/03  |  |              |
| D.KOZAR          | 5/13/03  |  |              |
| A.VYSOTSKY       | 5/13/03  | LOAD BANK, PORTABLE,<br>INDOOR, 240/480V<br>(OUTLINE DWG SB3192)   |              |
| SIZE             | CAGE NO. | DWG. NO.   | REV          |
| D                | 01014    | LPH100   | D34963       |
| SCALE            | 1/1      | MODEL  | LPH 100      |
|                  |          |  | SHEET 1 OF 3 |

| REVISIONS |     |                               |                  |          |
|-----------|-----|-------------------------------|------------------|----------|
| ECN NO.   | REV | DESCRIPTION                   | DATE             | APPROVED |
| CD698     | B   | RELOCATED "SEE NOTE 3".       | J.FLAUTO 5-17-04 | J.HUDSON |
| CD809     | D   | ADDED "240/480V" IN TITLE BLK | MJ 10/01/04      | J.HUDSON |

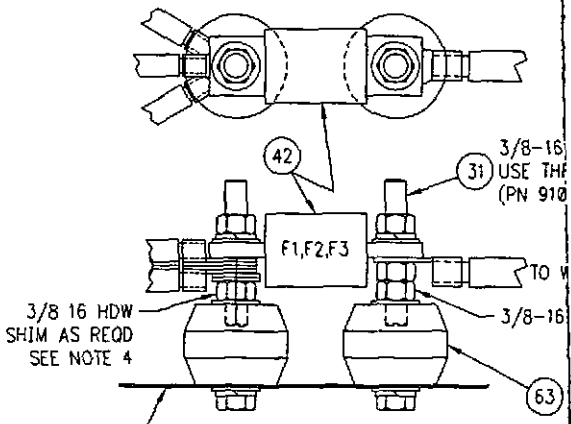

**DETAIL A**  
SCALE: 5/8  
TYP 3 PLACES

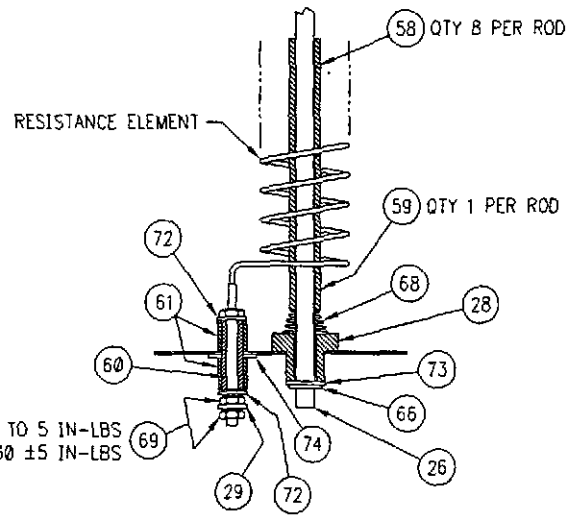

**SECTION B-B**  
SCALE: 5/8

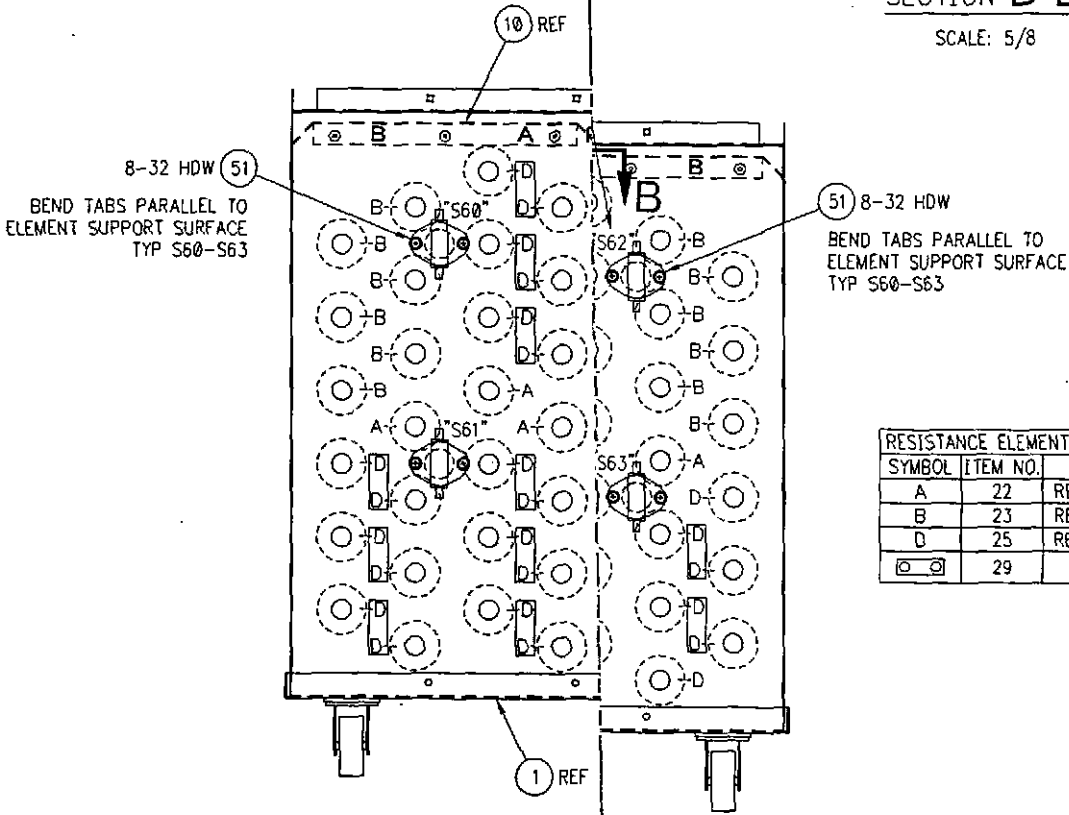

| RESISTANCE ELEMENT AND BUS BAR CODE |          |                    |
|-------------------------------------|----------|--------------------|
| SYMBOL                              | ITEM NO. | DESCRIPTION        |
| A                                   | 22       | RESISTANCE ELEMENT |
| B                                   | 23       | RESISTANCE ELEMENT |
| D                                   | 25       | RESISTANCE ELEMENT |
|                                     | 29       | BUS BAR            |

AVTRON MANUFACTURING INC  
7000 E.PLEASANT VALLEY ROAD  
INDEPENDENCE, OH 44131-5529

LOAD BANK, PORTABLE,  
INDOOR, 240/480V

|  |            |                |                        |        |
|--|------------|----------------|------------------------|--------|
| UNLESS OTHERWISE SPECIFIED THE ABOVE NOTES APPLY | SIZE D     | CAGE NO. 01014 | DWG. NO. LPH100 D34963 | REV. E |
| SEE SHEET 1 FOR NOTES                            | SCALE 5/16 | MODEL LPH 100  | SHEET 2                |        |

| REVISIONS |     |  |            |          |
|-----------|-----|--|------------|----------|
| ECN NO.   | REV | DESCRIPTION  | DATE       | APPROVED |
| CD410     | A   | REVISED DETAIL D PER ECN   | FACKELMANN | 6/30/03  |
| CD698     | B   | REVISED GND PICTORIAL ON RIGHT SIDE VIEW. J.FLAUTO   |            | 5-17-04  |
| CD809     | D   | REV "REF B" IN DETAIL C; REV PICTORIAL & TITLE BLK M.J. CHNG EFFECT S.N. 169,170,173 & ABOVE |            | 10/01/04 |
| CE211     | E   | REVISED PICTORIAL PER ECN  | FACKELMANN | 12/5/05  |

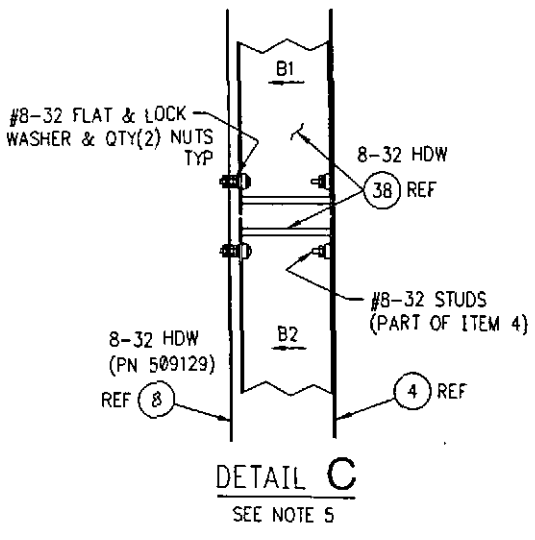

REF

3/8-16 SST HDW  
(USE BOLT PN 507201  
AND NUTS PN 516110)

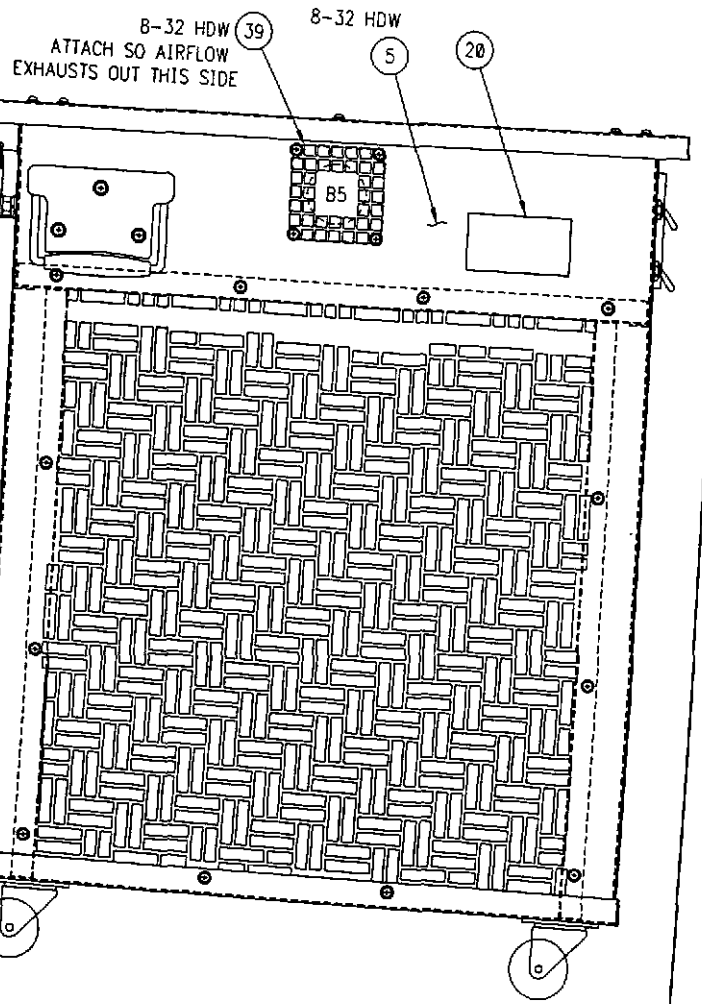
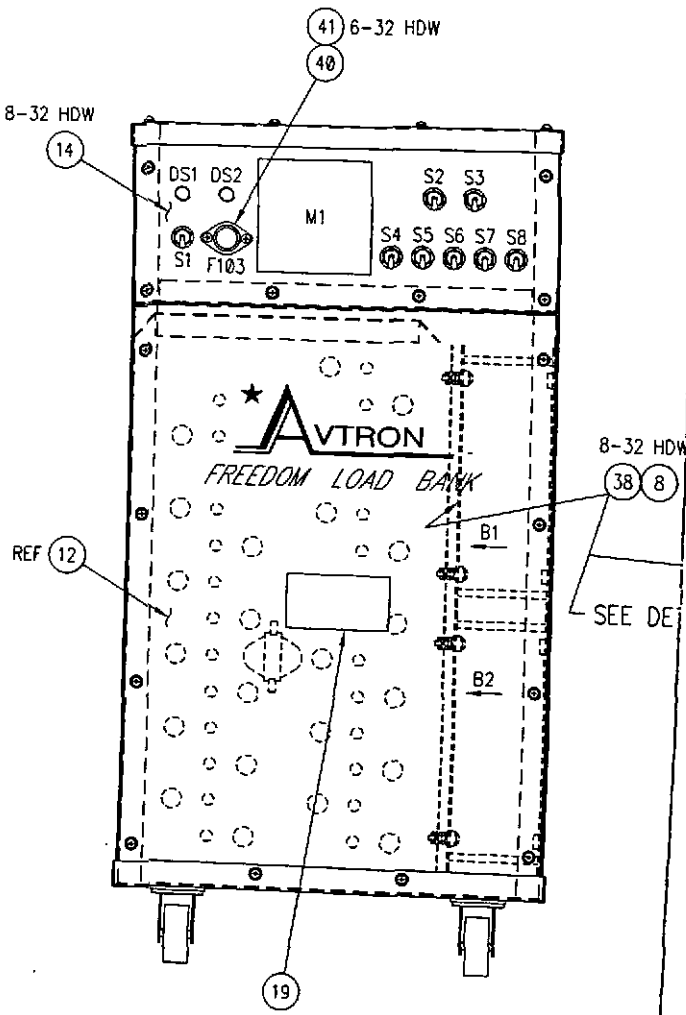

SEE SHEET 1 FOR NOTES  
UNLESS OTHERWISE SPECIFIED THE ABOVE NOTES APPLY

AVTRON MANUFACTURING INC  
7900 E PLEASANT VALLEY ROAD  
INDEPENDENCE, OH 44131-5528

LOAD BANK, PORTABLE,  
INDOOR, 240/480V

|   |                  |          |               |     |
|---|------------------|----------|---------------|-----|
| UNLESS PROPRIETARY INFORMATION AND MAY NOT BE DISCLOSED FOR MANUFACTURING PURPOSES WITHOUT THE CONSENT OF AVTRON MFG. | SIZE             | CAGE NO. | DWG NO.       | REV |
|   | D                | 01014    | LPH100 D34963 |     |
|   | SCALE 5/16" = 1" |          |               |     |

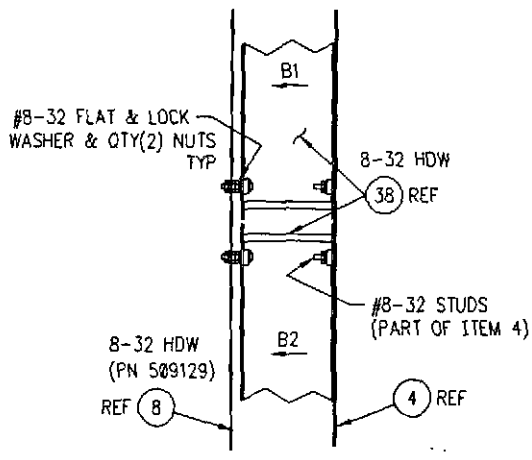

**DETAIL C**  
SEE NOTE 5

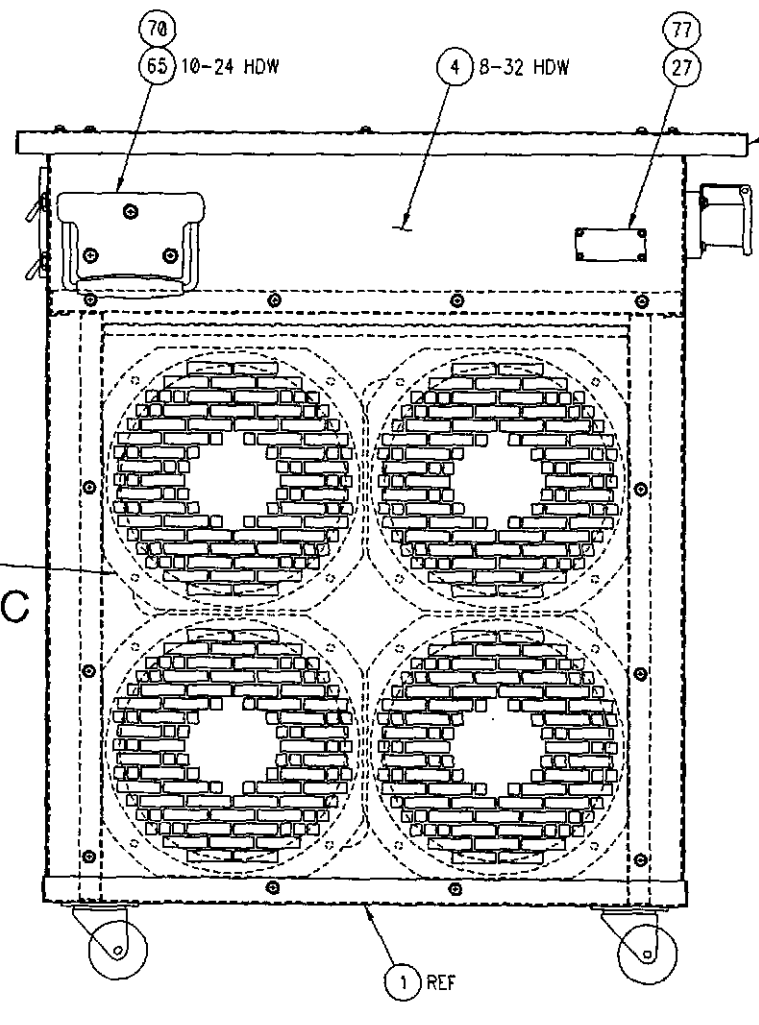
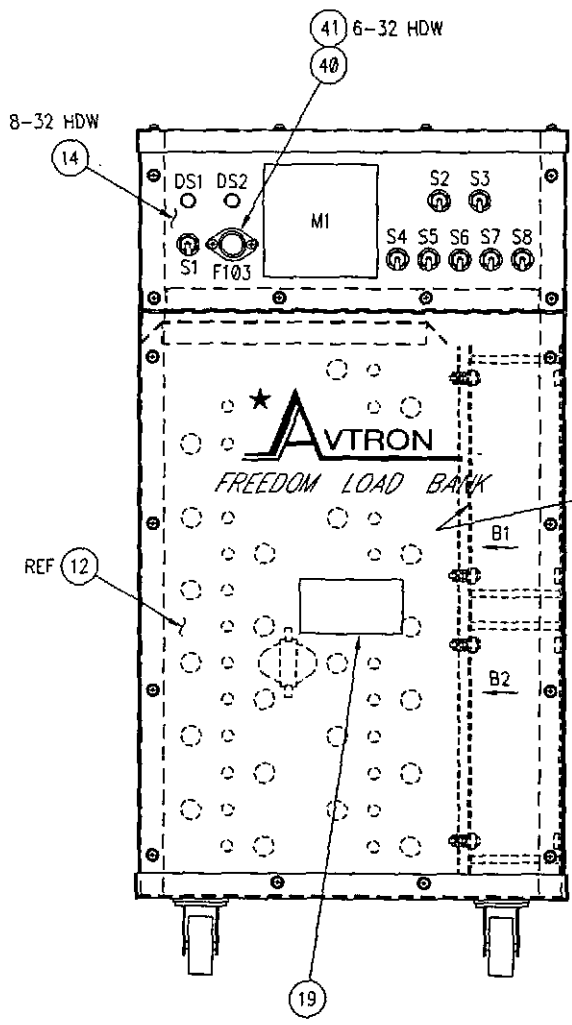
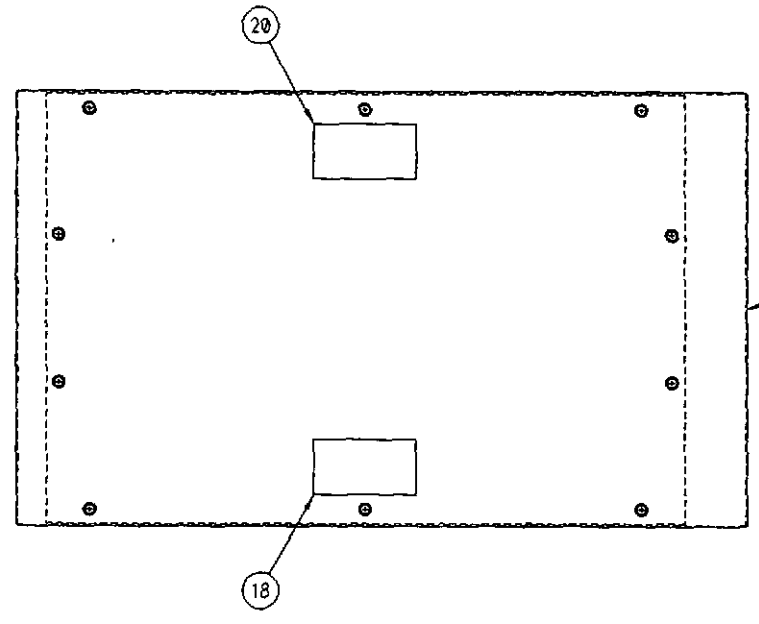

8-32 HDW (38) (8)

SEE DETAIL C

| REVISIONS |     |   |            |          |           |
|-----------|-----|---|------------|----------|-----------|
| ECN NO.   | REV | DESCRIPTION   | DATE       | APPROVED |           |
| CD410     | A   | REVISED DETAIL D PER ECN  | FACKELMANN | 6/30/03  | J. HUDSON |
| CD698     | B   | REVISED GND PICTORIAL ON RIGHT SIDE VIEW. J.FLAUTO  |            | 5-17-04  | J. HUDSON |
| CD809     | D   | REV "REF 8" IN DETAIL C; REV PICTORIAL & TITLE BLK WJ<br>CHNG EFFECT S.N. 169,170,173 & ABOVE |            | 10/01/04 | J. HUDSON |
| CE211     | E   | REVISED PICTORIAL PER ECN   | FACKELMANN | 12/5/05  | J. HUDSON |

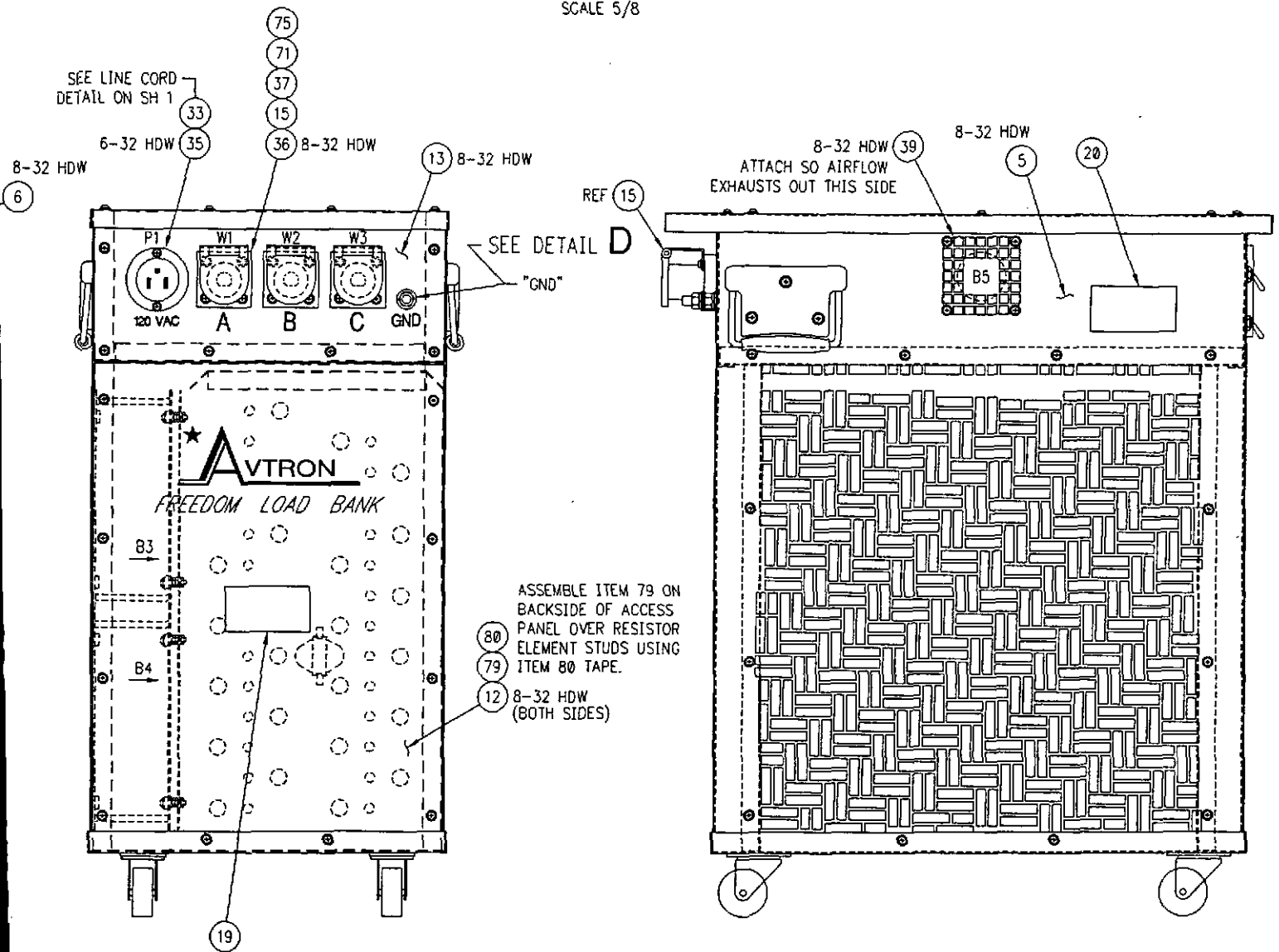
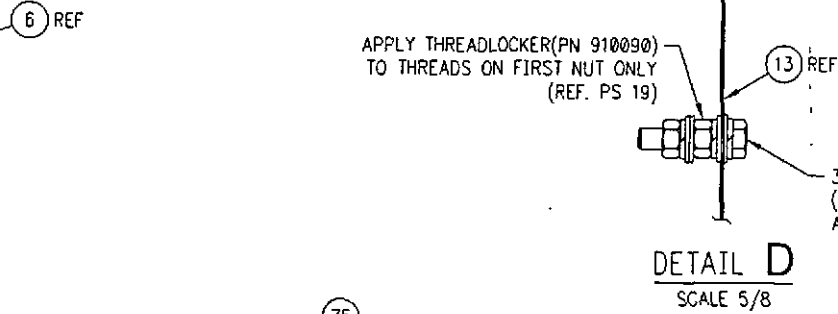

**AVTRON MANUFACTURING INC**  
 7988 E. PLEASANT VALLEY ROAD  
 INDEPENDENCE, OH 44131-5529

THIS DOCUMENT CONTAINS PROPRIETARY INFORMATION OF AVTRON MFG., INC. AND MAY NOT BE DISCLOSED TO OTHERS OR USED FOR MANUFACTURING PURPOSES WITHOUT THE WRITTEN CONSENT OF AVTRON MFG.

**LOAD BANK, PORTABLE, INDOOR, 240/480V**

|            |          |               |         |
|------------|----------|---------------|---------|
| SIZE       | CAGE NO. | DWG. NO.      | REV     |
| D          | 01014    | LPH100 D34963 | E       |
| SCALE 5/16 | MODEL    | LPH 100       | SHEET 3 |

P/N 315001 (12)  
P.S. # 37054 m21

# cam-lok® ASSEMBLY INSTRUCTIONS Series E1016 & E1018

EB 9

Page 1

**NOTE: USE COPPER (CU)  
CONDUCTORS ONLY.**

1. MEASURE CABLE JACKET.

2. CUT SLEEVE TO MATCH.

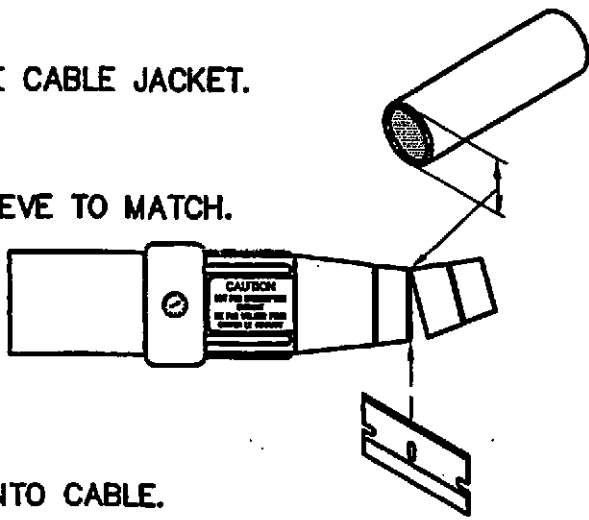

3. SLIDE ONTO CABLE.

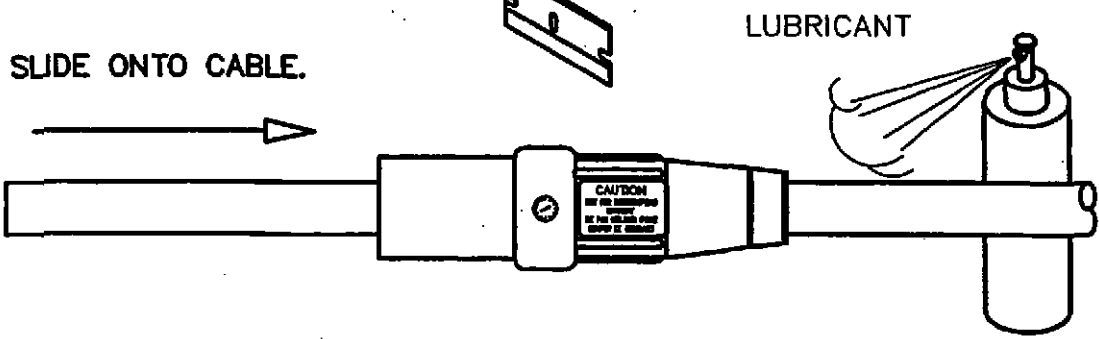

4. REMOVE JACKET.

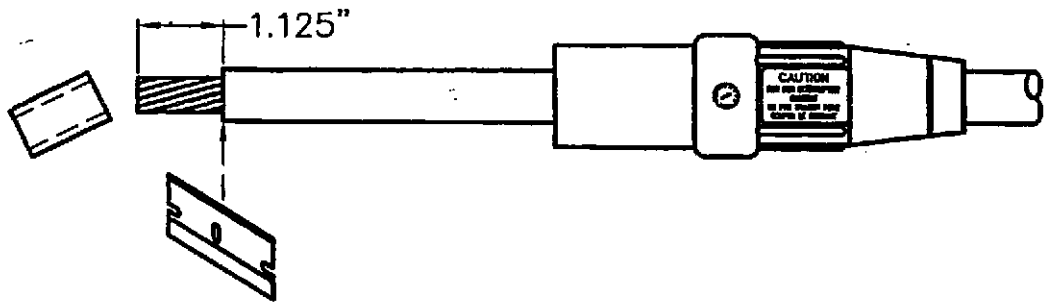

5. WRAP COPPER SHIM.

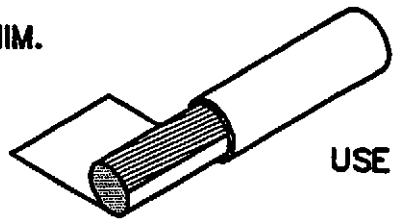

USE TWO FOR SMALLER CABLES.

**cam-lok®**  
**ASSEMBLY INSTRUCTIONS**  
 Series E1016 & E1018

**6. WRAP STRAIN RELIEF WIRE.**

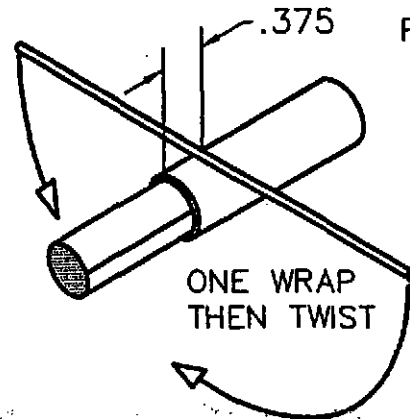
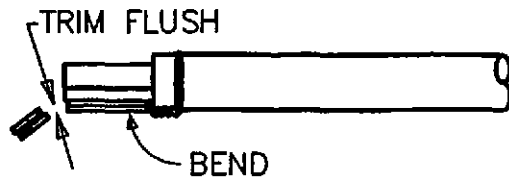

**7. INSERT INTO CONTACT.**

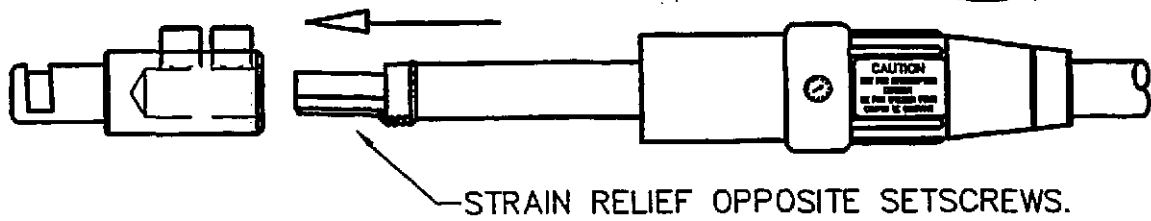

**8A. TIGHTEN SETSCREWS.**

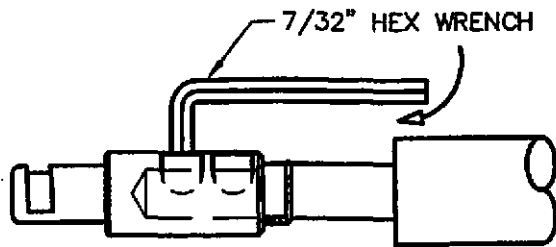

| CABLE SIZE | TORQUE INCH POUNDS |
|------------|--------------------|
| #2 - #1    | 100                |
| 1/0 - 2/0  | 120                |
| 3/0 - 4/0  | 220                |

**OR**

**8B. CRIMP CONTACT**

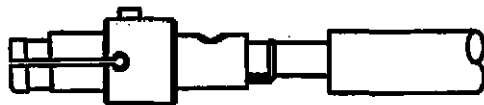

| CABLE SIZE | CRIMP NEST | CRIMP PRESS |
|------------|------------|-------------|
| #2 - #1    | 100514-3   | A200914-3   |
| 1/0 - 2/0  | 100514-4   | A200914-4   |
| 3/0        | 100514-5   | A200914-5   |
| 4/0        | 100514-6   | A200914-6   |

**9. LUBRICATE CONTACT.**

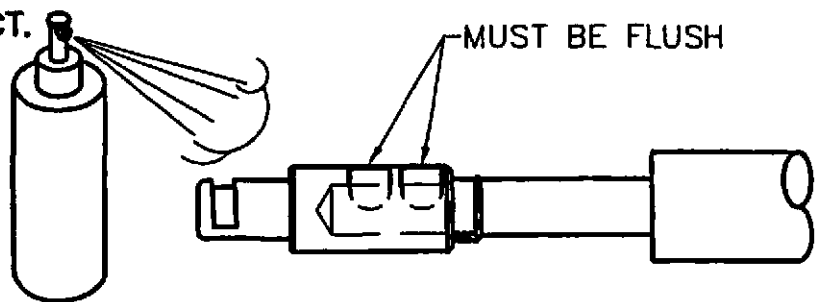

**cam-lok®**  
**ASSEMBLY INSTRUCTIONS**  
 Series E1016 & E1018

EB 9

Page 3

10. LINE UP PIN WITH ARROW.

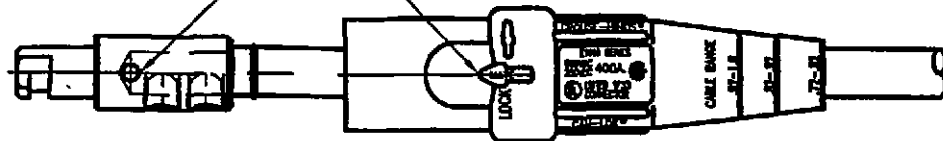

11. PUSH SLEEVE OVER CONTACT.

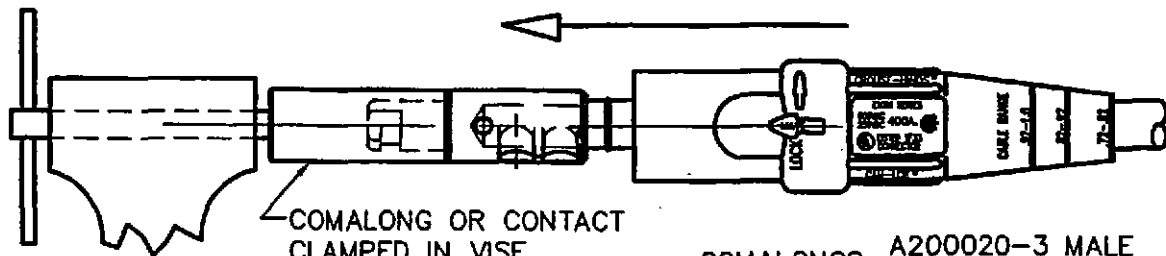

12. PIN MUST POP INTO POCKET.

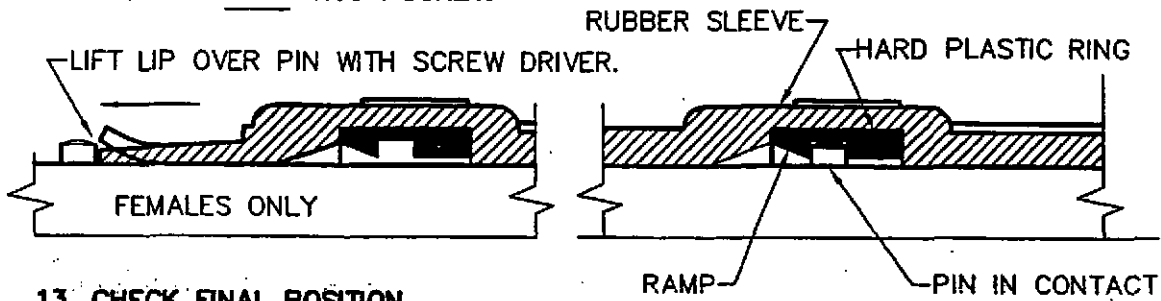

13. CHECK FINAL POSITION.

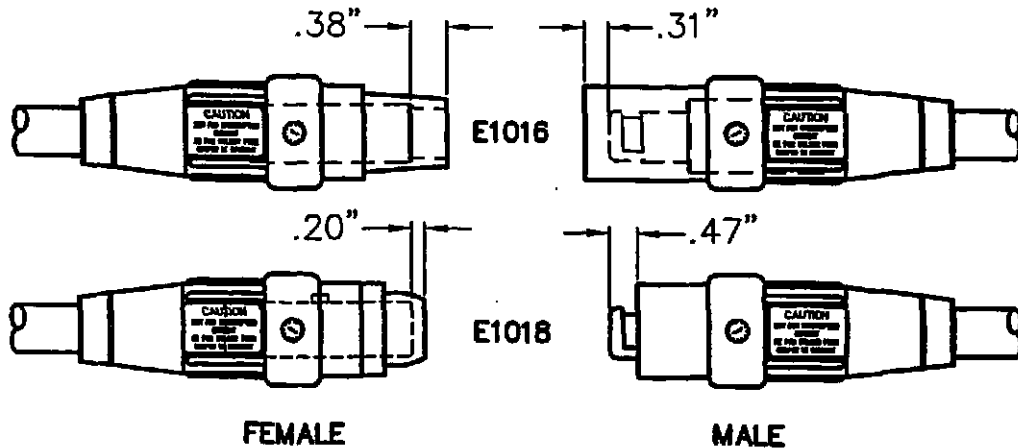

**cam-lok<sup>®</sup>**  
**ASSEMBLY INSTRUCTIONS**  
Series E1016 & E1018

EB 9

Page 4

SLEEVE REMOVAL PROCEDURE

1. MATE WITH COMALONG OR CONTACT.

COMALONGS: A200020-3 MALE  
A200020-4 FEMALE

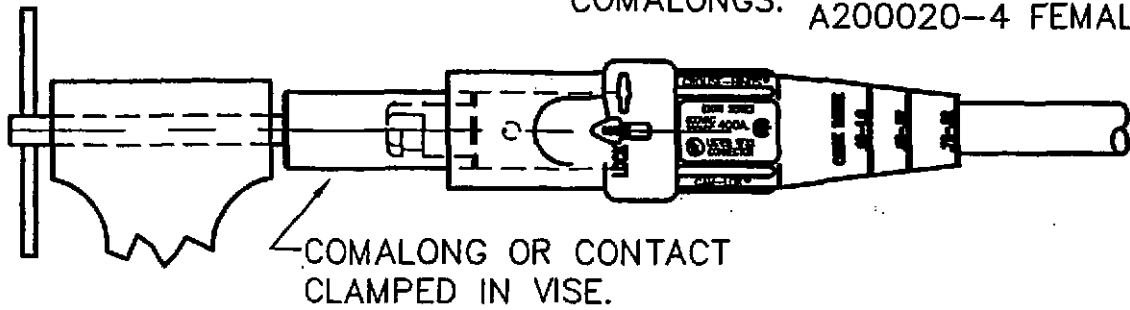

2. INSERT 1/4" WIDE SCREW-DRIVER INTO KEYWAY.

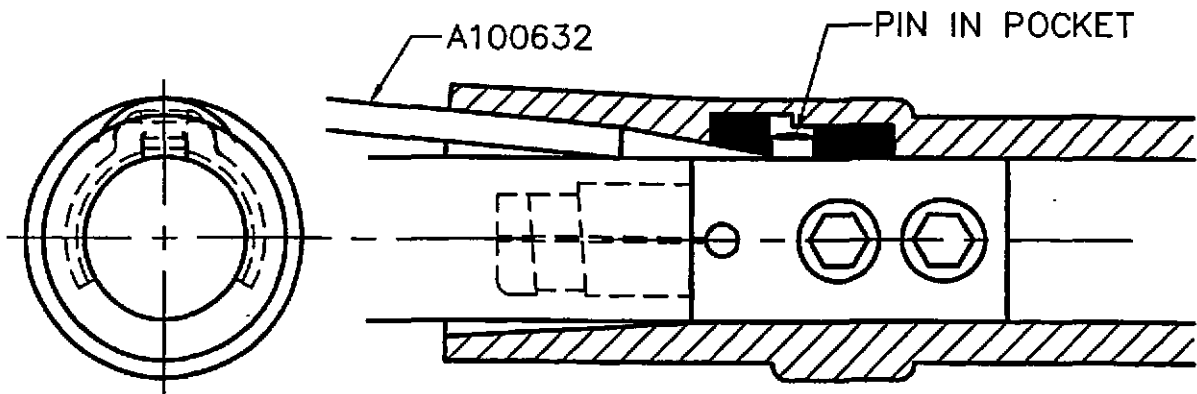

3. ROTATE BLADE 90° TO LIFT RING OFF PIN.

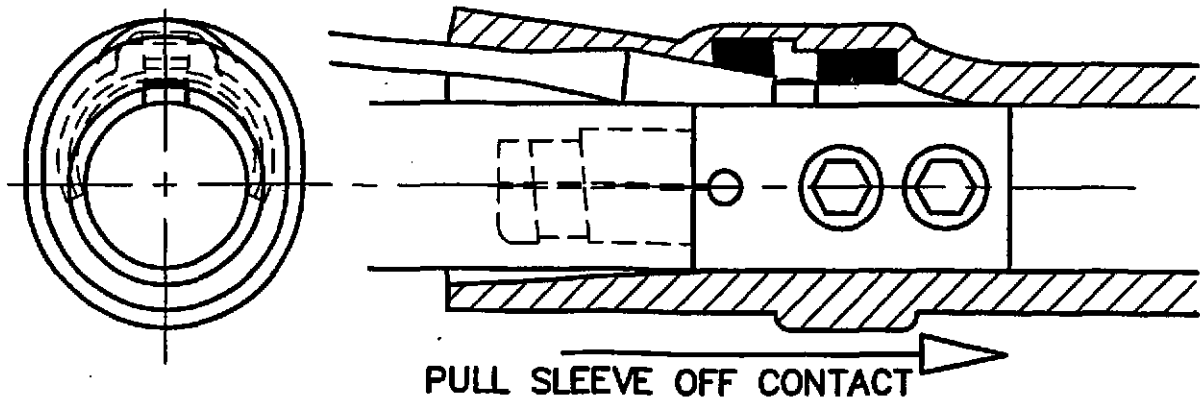

**cam-lok®**  
**ASSEMBLY INSTRUCTIONS**  
**Series E1016 & E1018**

EB 9

Page 5

| CONTACT AND CONDUCTOR SIZE INFORMATION |                  |                |                         |                             |             |             |
|--|------------------|----------------|-------------------------|-----------------------------|-------------|-------------|
| Series                                 | Style            | Conductor Size | Continuous Amp Rating   | Conductor Entrance Diameter | Contact     |             |
|  |                  |                |                         |                             | Male        | Female      |
| E1016                                  | CRIMP            | #2-#1          | 170                     | .402                        | A200036-18  | A200037-23  |
| E1016                                  | CRIMP            | 1/0-2/0        | 235                     | .495                        | A200036-19  | A200037-24  |
| E1016                                  | CRIMP            | 1/0-2/0 HD     | 235                     | .495                        | A200038-11B | A200035-17B |
| E1016                                  | CRIMP            | 3/0-4/0        | 315                     | .620                        | A200038-6B  | A200035-14B |
| E1016                                  | SINGLE SET SCREW | #2-2/0         | 235                     | .578                        | A200065-1   | A200067-3   |
| E1016                                  | SINGLE SET SCREW | 3/0-4/0        | 315                     | .656                        | A200064-1   | A200090-1   |
| E1016                                  | DOUBLE SET SCREW | #2-2/0         | 235                     | .578                        | A200630-1   | A200640-3   |
| E1016                                  | DOUBLE SET SCREW | 3/0-4/0        | 400--USE<br>105°C CABLE | .656                        | A200639-1   | A200641-1   |
| E1018                                  | CRIMP            | #2-#1          | 170                     | .402                        | A200036-2   | A200037-6   |
| E1018                                  | CRIMP            | 1/0-2/0        | 235                     | .495                        | A200036-3   | A200037-7   |
| E1018                                  | CRIMP            | 3/0-4/0        | 400                     | .620                        | A200038-2   | A200035-4   |

For high volume or frequent installation, use the Lektralink assembly tool as shown below. The part number is A400001. Complete instructions for use are included with tool.

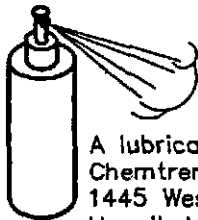

A lubricant is available from:  
 Chemtrend, Inc.  
 1445 West McPherson Park Drive  
 Howell, Michigan 48844-0860  
 Their part number is CT-39F.

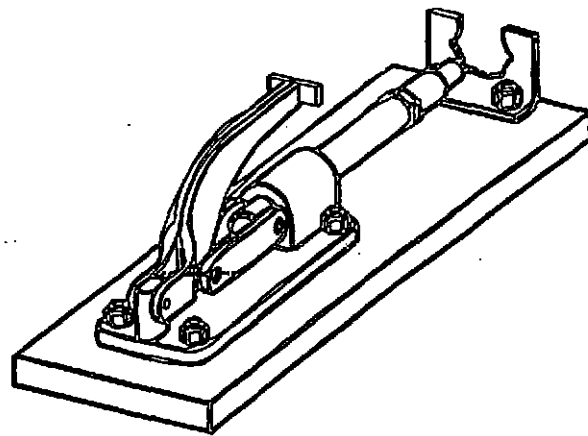

**COOPER Crouse-Hinds**

**Crouse-Hinds Molded Products**

**UNITED STATES:**

4758 Washington Street • LaGrange, North Carolina 28561  
 Phone (252) 666-3014 • FSCM-90129 • FAX (252) 666-9337

**CANADA:**

Crouse-Hinds Canada Ltd.  
 5925 McLaughlin Road • Mississauga, Ontario L5R 1B5  
 Phone (905) 507-4187 • FAX (905) 501-4078

# Warranty

## Warranty and Duration

For a period of one year after installation, or fifteen (15) months from date of shipment from our plant, whichever is shorter, Avtron warrants the equipment, except as hereinafter provided, to be free from harmful defects in material and workmanship. Notwithstanding any other term or provision in this Warranty, the warranty provided herein shall terminate unless buyer notifies Avtron, in writing, of a breach hereof within the warranty period; any claims not made within such period are waived by Buyer. The warranty provided herein applies only if Buyer complies with all the other terms and provisions of this Warranty.

## Uses of Equipment

The warranty provided herein applies only if the equipment has been used in a normal and proper manner under recommended conditions. Notwithstanding any advice or assistance given to the Buyer by Avtron or its suppliers concerning the equipment or its use, Avtron makes no express or implied warranties or representations, except as herein expressly provided, with respect to the equipment or its use, and Avtron shall not be liable in contract, warranty or tort (including, without limitation, for negligence or strict liability) as a result of such advice or assistance. In addition, unless otherwise agreed in writing signed by a duly authorized representative of Avtron, no equipment covered by this warranty is intended to be used in connection with any nuclear facility or activity, and if so used, Avtron disclaims any and all liability for any damage resulting therefrom.

## Notification of Breach

When claiming a breach of this Warranty, Buyer must promptly (within 10 days from the date of the discovery of the defect) notify Avtron in writing.

## Equipment Disposition

Upon notification of a claimed breach of this Warranty, Avtron, at its discretion, will either authorize the return of the defective equipment or part thereof (transportation costs to be prepaid by Buyer) or provide a suitable replacement or authorize the Buyer in writing to effect repairs at Avtron's expense. In the event that the equipment returned as authorized is found to be defective and Avtron elects to repair or replace said equipment, Avtron will pay the transportation costs associated with the return of said equipment to Buyer. Avtron shall not however be liable for any customs, tariffs, duties or taxes incurred in shipping equipment pursuant to this Warranty. These shall be the responsibility of the Buyer.

## Option of Avtron to Repair or Replace Equipment or to Issue Credit

Avtron's sole obligation under this Warranty shall be, at the option of Avtron, to replace or repair any defective equipment or part thereof or to issue a credit with respect to the defective equipment equal to the purchase price thereof less depreciation.

**Equipment Excluded From Warranty**

The warranty provided herein specifically excludes equipment and components that Avtron purchases and resells as part of a system, product or spare part order. The warranties provided to Avtron by the manufacturers of the foregoing equipment and components will, to the extent possible, be passed on to the Buyer. Copies of such warranties, if on file at Avtron, will be made available for inspection upon the request of Buyer. Equipment such as, but not limited to, computers, CRTs, operator interface modules, monitors, etc., normally have a short warranty period and should be covered by a continuous service contract generally available from the original manufacturer at a reasonable cost. Consumable items including, but not limited to, lamps, filters, fuses and motor brushes are excluded from all warranties. Other items or components may be excluded from this warranty if so noted in the governing purchase order or contract.

**Resale or Lease of Equipment**

In the event that the Buyer resells or leases equipment purchased from Avtron, the Buyer shall obtain the signed written agreement of the purchaser or lessee thereof that Avtron's only liability with respect to said equipment is as set forth in this Warranty. In the event that the Buyer fails to obtain such a signed written agreement, the Buyer agrees to indemnify Avtron against any claims, demands, judgments, suits, costs, liabilities and expenses (including reasonable attorney's fees) incurred by Avtron as a result of such failure.

**Unauthorized Repairs**

Unless otherwise agreed in writing signed by a duly authorized representative of Avtron, if the Buyer has repairs or modifications made to equipment covered by this Warranty by a person other than an authorized Avtron service representative, Avtron shall not be liable for any expenses incurred in connection therewith and the warranty provided herein shall automatically be terminated.

**Governing Law; Saving Clause**

This Warranty is part of the terms and conditions of the sale of the equipment covered hereunder and shall be governed by and enforced in accordance with the laws of the State of Ohio. Any provision hereof which is prohibited or unenforceable in any jurisdiction shall, as to such jurisdiction, be ineffective to the extent of such prohibition or unenforceability without invalidating the remaining provisions hereof or affecting the validity or enforceability of such provision in any other jurisdiction.

**Limitation of Liability**

IN NO EVENT SHALL AVTRON BE LIABLE IN CONTRACT, IN TORT OR OTHERWISE FOR SPECIAL, INCIDENTAL, CONSEQUENTIAL OR PUNITIVE DAMAGES (INCLUDING, BUT NOT LIMITED TO, LOSS OF PROFITS OR REVENUES, LOSS OF USE OF THE EQUIPMENT OR ANY DAMAGE TO ASSOCIATED EQUIPMENT, DAMAGE OR INJURY TO PERSONS OR PROPERTY, COST OF CAPITAL, COST OF SUBSTITUTE OR TEMPORARY EQUIPMENT, DOWNTIME OR CLAIMS OF CUSTOMERS) ARISING OUT OF OR AS A RESULT OF BREACH OF WARRANTY, DEFECT IN MATERIAL OR WORKMANSHIP OR ANY OTHER OBLIGATION OF AVTRON HEREUNDER.

**Disclaimer of All Other Warranties**

THIS WARRANTY COMPRISES AVTRON'S SOLE AND ENTIRE WARRANTY OBLIGATION TO BUYER, ITS CUSTOMERS AND ASSIGNS IN CONNECTION WITH EQUIPMENT SOLD, ASSIGNED, LEASED OR OTHERWISE DEALT WITH BY AVTRON. ALL OTHER WARRANTIES, EXPRESS OR IMPLIED, INCLUDING, BUT NOT LIMITED TO, WARRANTIES OF MERCHANTABILITY AND FITNESS, ARE EXPRESSLY EXCLUDED.

