

ELEMENT SUPPORT
"COMPONENT SIDE" (LEFT SIDE)

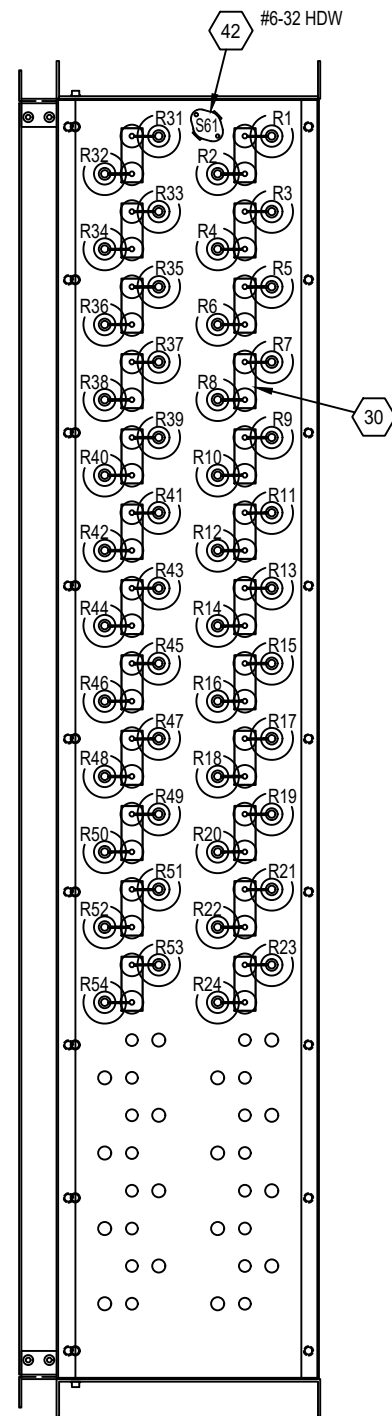

ELEMENT SUPPORT
"CONNECTION SIDE" (RIGHT SIDE)

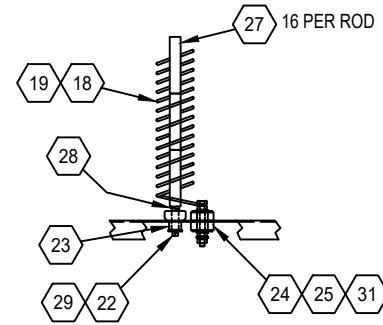
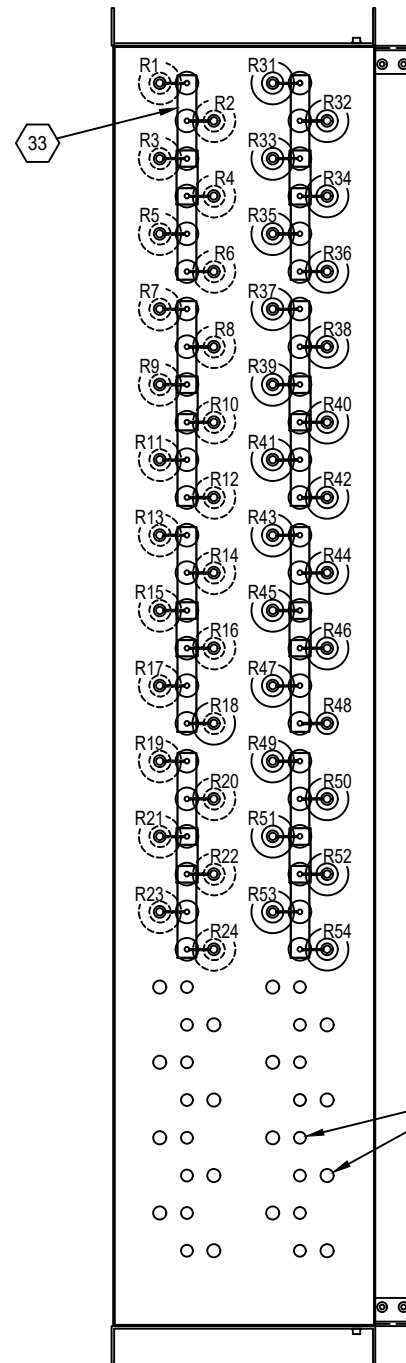

CONTROL PANEL
SCALE: 2 / 1

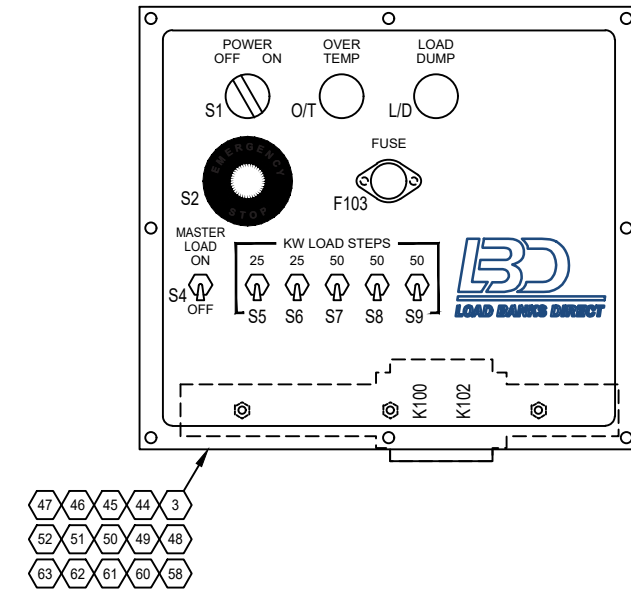

GENERAL NOTES:

- A. UNLESS OTHERWISE NOTED:
1. ALL DIMENSIONS ARE IN INCHES.

LD Load Banks Direct
www.LoadBanksDirect.com

TEXT **LOAD BANK, 200KW, 208V, 25KW RES**
(WITH CONTROL POWER XFMR)

DWG. NO. LD200-208-25T-74-68-BM	REV. -	SHEET 2 of 2
---	------------------	------------------------

DRAWN BY ELM	CHK'D BY MMP	DATE 1-23-18	SIZE D
------------------------	------------------------	------------------------	------------------

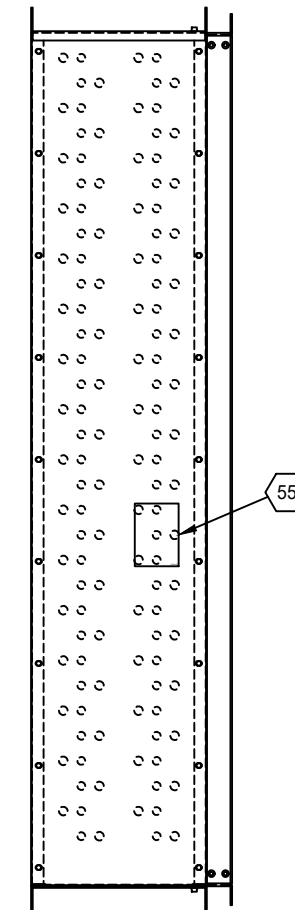
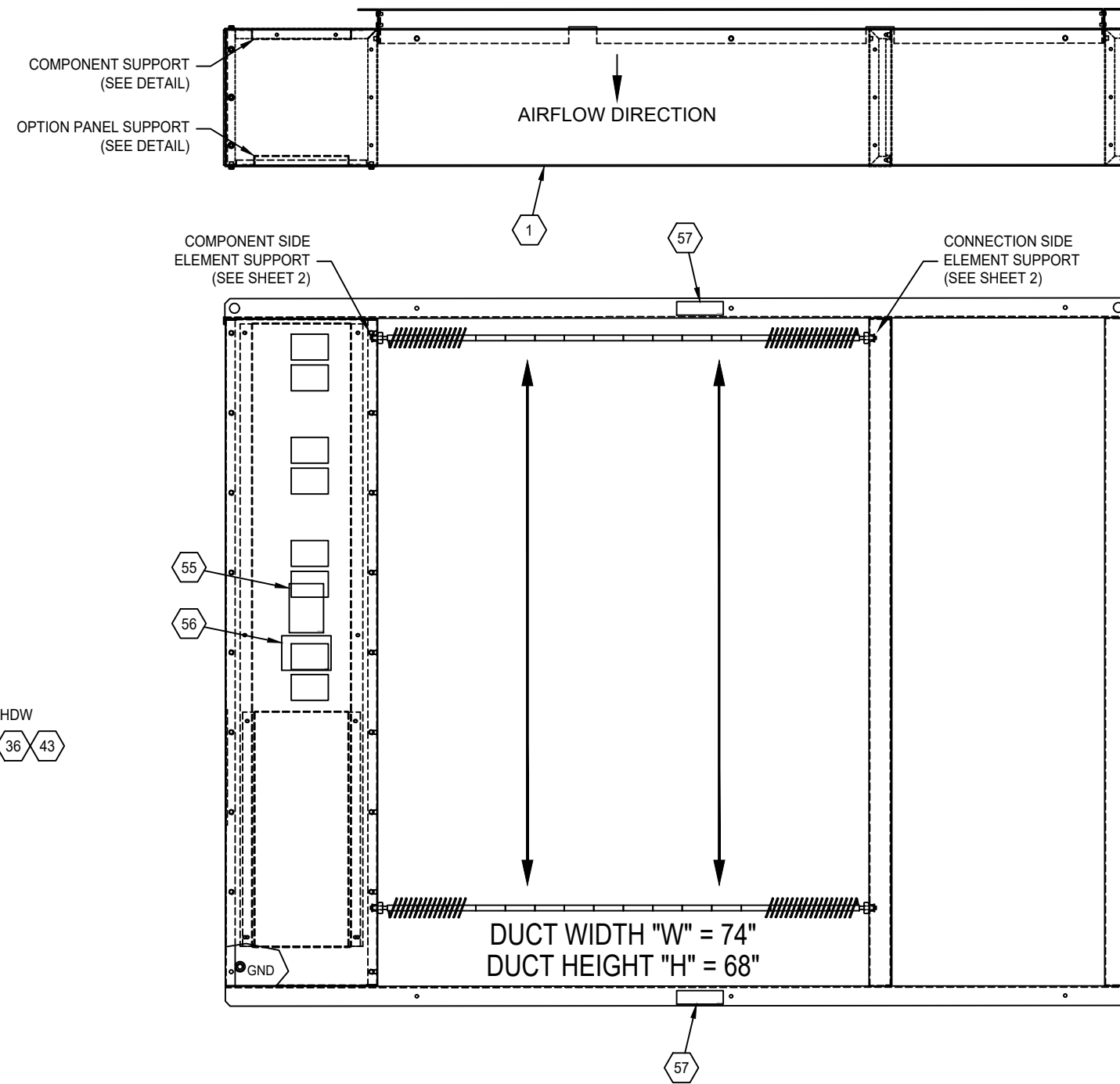
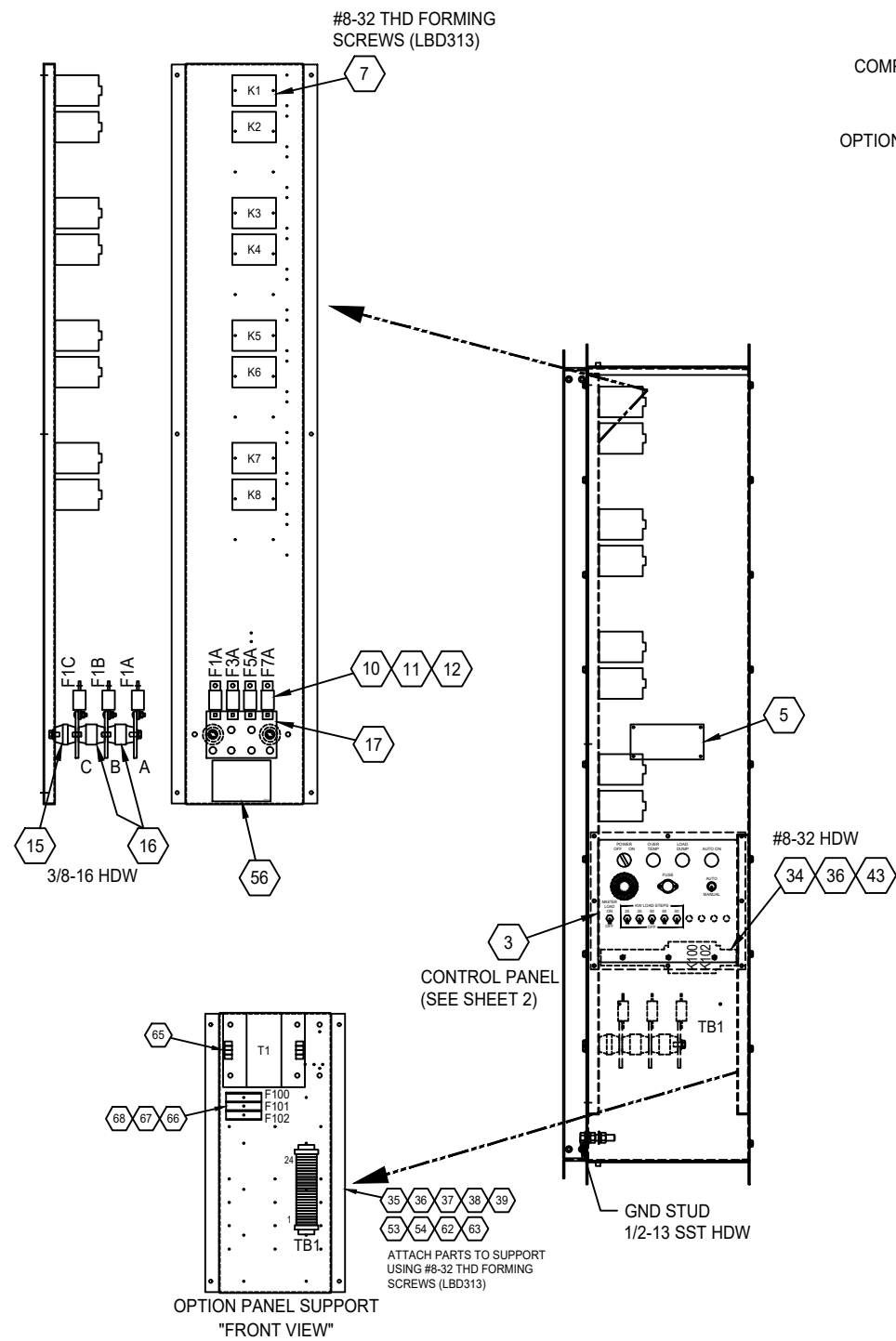

GENERAL NOTES:
 A. UNLESS OTHERWISE NOTED:
 1. ALL DIMENSIONS ARE IN INCHES.

 Load Banks Direct www.LoadBanksDirect.com			
LOAD BANK, 200KW, 208V, 25KW RES (WITH CONTROL POWER XFMR)			
DWG. NO. LD200-208-25T-74-68-BM	REV. -	SHEET 1 of 2	
DRAWN BY ELM	CHK'D BY MMP	DATE 1-23-18	SIZE D

LOAD BANK LD200-208-25T

NOTES:

- 1) OPTIONAL REMOTE LOAD DUMP - CONNECT NORMALLY CLOSED (N.C.) SET OF AUX CONTACTS FOR REMOTE LOAD DUMP.
- 2) AUX CONTACTS PROVIDED FOR REMOTE INDICATION AND / OR ALARM.

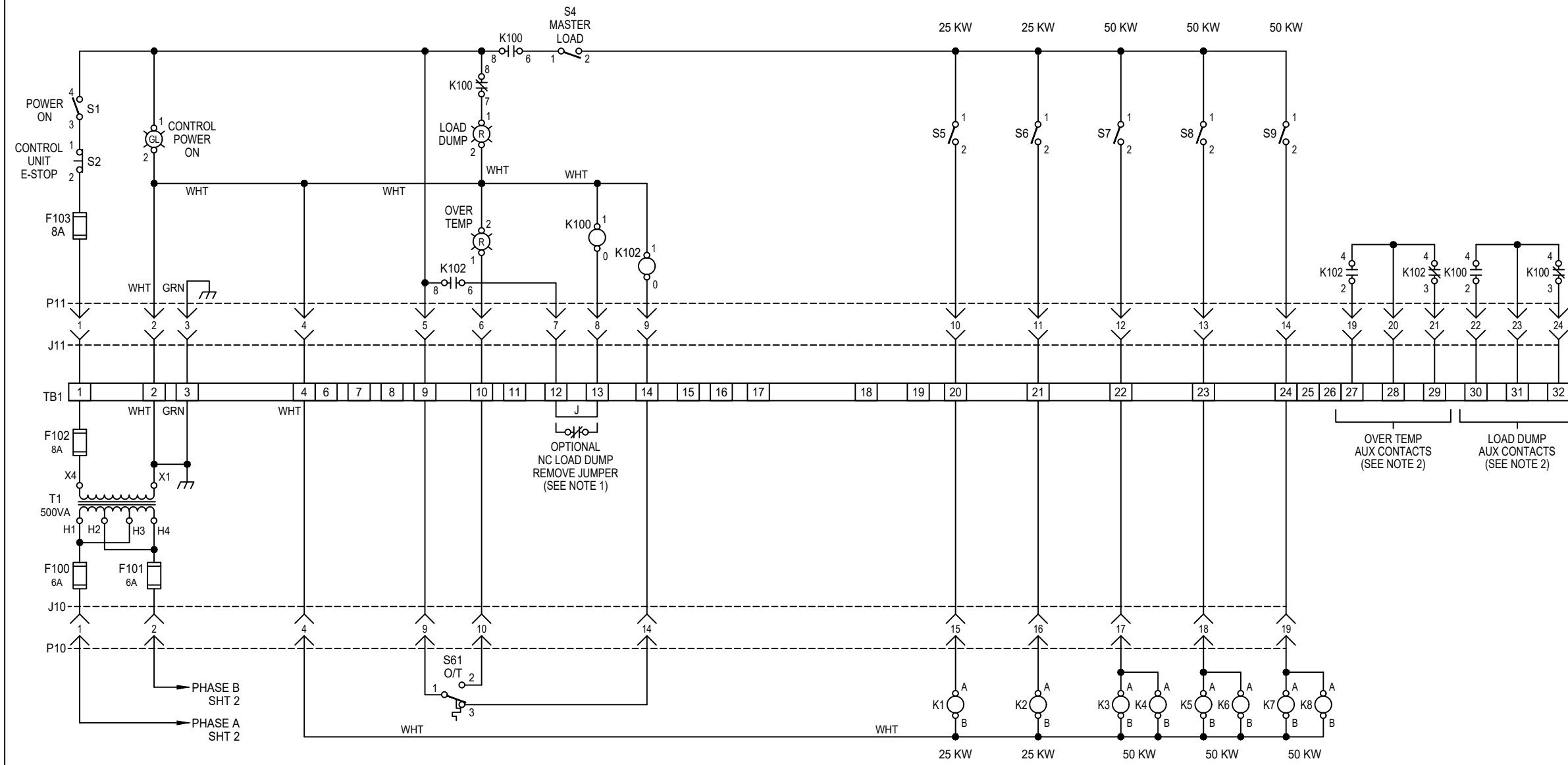

GENERAL NOTES:

A. UNLESS OTHERWISE NOTED:
 1. ALL DIMENSIONS ARE IN INCHES.

THIS DRAWING IS PROPERTY OF LOAD BANKS DIRECT AND SHALL REMAIN SO WHILE IN USER'S POSSESSION. THE TECHNOLOGY SHOWN HERE IS STRICTLY PROPRIETARY AND IS NOT TO BE DISCLOSED TO ANY 3RD PARTY WITHOUT LOAD BANKS DIRECT PRIOR CONSENT.

 Load Banks Direct www.LoadBanksDirect.com			
SCHEMATIC, LOAD BANK			
DWG. NO.	REV.	SHEET	
LD200-208-25T-W	-	1 of 2	
DRAWN BY	CHK'D BY	DATE	SIZE
ELM	MMP	1-23-18	D

- 4 - DENOTES #4 AWG HIGH TEMP 150 °C, 600 VAC INSULATED UL 3321 OR UL 3374.
 - 10 - DENOTES #10 AWG HIGH TEMP 150 °C, 600 VAC INSULATED UL 3321 OR UL 3374.
 - 12 - DENOTES #12 AWG HIGH TEMP 150 °C, 600 VAC INSULATED UL 3321 OR UL 3374.
 - 4 - DENOTES #4 AWG BLACK WIRE, UL TYPE 1015 (CSA TYPE TEW OR AWM), WIRE TYPE MTW-THHN, 105 °C, 600 VAC INSULATED.
 - 10 - DENOTES #10 AWG BLACK WIRE, UL TYPE 1015 (CSA TYPE TEW OR AWM), WIRE TYPE MTW-THHN, 105 °C, 600 VAC INSULATED.
 - 12 - DENOTES #12 AWG BLACK WIRE, UL TYPE 1015 (CSA TYPE TEW OR AWM), WIRE TYPE MTW-THHN, 105 °C, 600 VAC INSULATED.
- ALL UNMARKED WIRE TO BE #16 AWG BLACK, UL TYPE 1015 (CSA TYPE TEW OR AWM), WIRE TYPE MTW-THHN, 105 °C, 600 VAC INSULATED.
 ALL WIRE TO BE BLACK UNLESS SPECIFIED.

LOAD BANK LD200-208-25T

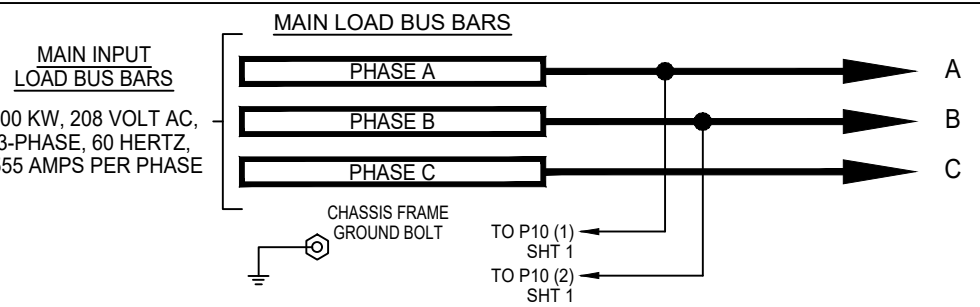

NOTE: ALL LOAD WIRING FROM RA1 AND LOAD STEP CONTACTORS TO BE WIRED DIRECTLY TO RESPECTIVE DESIGNATED LOAD STEP FUSE.

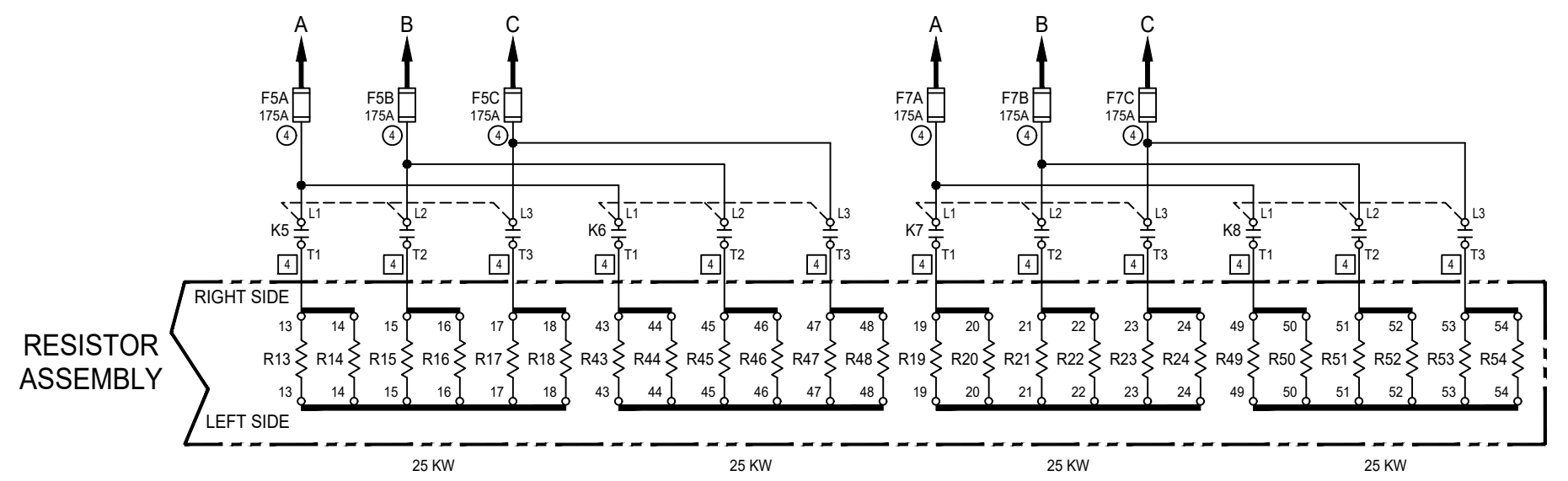
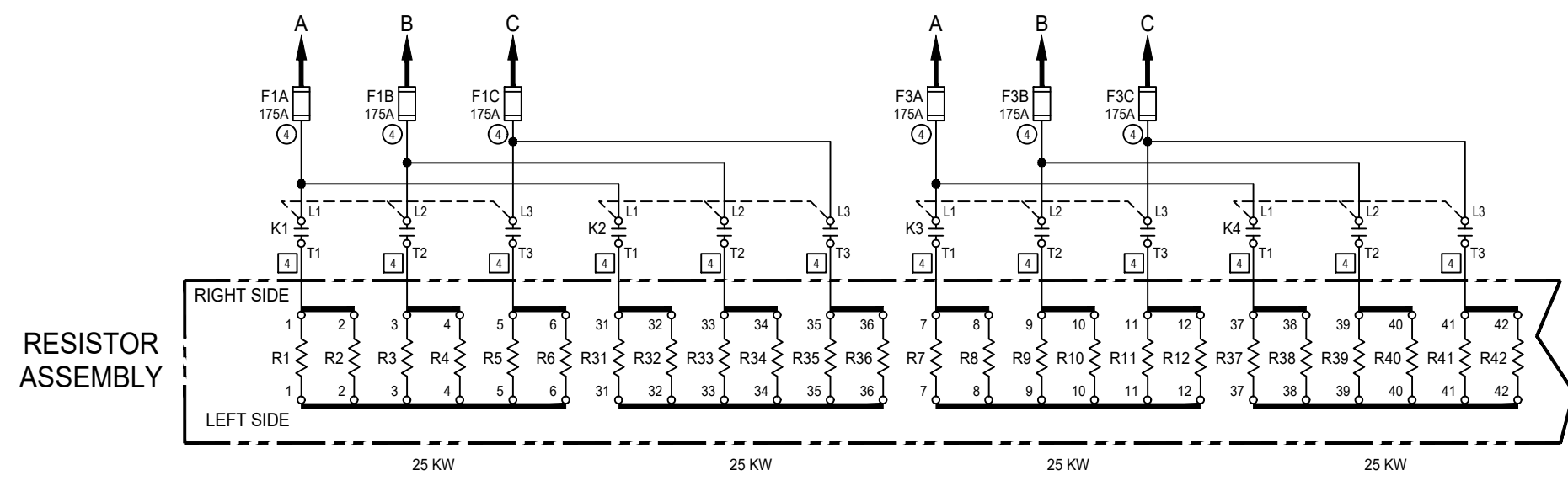

GENERAL NOTES:

A. UNLESS OTHERWISE NOTED:

1. ALL DIMENSIONS ARE IN INCHES.

THIS DRAWING IS PROPERTY OF LOAD BANKS DIRECT AND SHALL REMAIN SO WHILE IN USER'S POSSESSION. THE TECHNOLOGY SHOWN HERE IS STRICTLY PROPRIETARY AND IS NOT TO BE DISCLOSED TO ANY 3RD PARTY WITHOUT LOAD BANKS DIRECT PRIOR CONSENT.

 Load Banks Direct www.LoadBanksDirect.com		TEXT	
		SCHEMATIC, LOAD BANK	
DWG. NO.	REV.	SHEET	
LD200-208-25T-W	-	2 of 2	
DRAWN BY	CHK'D BY	DATE	SIZE
ELM	MMP	1-23-18	D

LD Series Radiator Duct Mounted Resistive Load Banks

IMPORTANT: These instructions should be read thoroughly before installation. All warnings and precautions should be observed for personal safety, proper equipment performance and longevity. Failure to follow these instructions could result in equipment failure, serious injury to personnel, and/or property damage. Load Banks contain lethal voltages when connected to the power source. It is very important to remove all sources of power to the load circuits, resistors, blower motor circuits, and control circuits before installing, operating, or servicing this unit. Always allow adequate time after removing power before touching any system components.

PROPRIETARY: This document is the property of Load Banks Direct LLC, and shall remain so **while in user's possession**. The information is provided for the instruction, operation, maintenance and service of this equipment and not to be used for manufacturing or procurement of equipment from any source other than Load Banks Direct LLC. The technology shown here is strictly proprietary and is not to be disclosed to any 3rd party without prior consent and the express written permission of Load Banks Direct LLC.

Table of Contents

Safety Points	3
Safety Precautions.....	3
Shock Hazard	3
Do Not Service or Adjust Alone	3
Safety Earth Ground	4
Potentially Hazardous Operator Conditions	4
Cooling Airflow Installation Requirements	5
Safety Symbols	7
Warning Statements	8
Caution Statements	9
Lingual General Safety Statements	10
Inspection and Unpacking	11
Product Overview	12
Definitions and Formulas	14
Theory of Operation	15
General.....	15
Equipment Cooling	15
Environmental Parameters	16
Equipment Installation	17
Equipment Placement and Location	17
Equipment Mounting.....	18
Power Connection Considerations.....	18
Power Connection Access	19
Main Input Load Bus Power Connections	19
Grounding	20
Control Power Circuit, and Control Power Transformer Circuit.....	20
Operator Controls	21
Multi-Power Meter.....	22
Automatic Load-Level Option.....	23
Operating Instructions	25
General.....	25
Operation.....	27
Safety and Shut-Down Indicators	28
Maintenance	29
Troubleshooting Guide	32
Storage	34
Shipping	34
Customer Service	34
Warranty	35
Electrical and Mechanical Ratings	36
Specifications	37
Parts List	39
Appendix – Drawings and Multi-Power Meter Quick Start Guide	42

Safety Points

Safety Precautions

The following instructions are general safety precautions that are not necessarily related to any specific part or procedure, and do not necessarily appear elsewhere in this publication. These precautions must be thoroughly understood and applied to all phases of operation and maintenance.

This manual contains various **Warning** and **Caution** statements. Personal injury or death may occur to an operator and/or technician if a warning statement is ignored. Equipment damage or hazardous conditions for personnel could result if caution or warning statements are ignored.

Carefully read and review this instruction manual, supplemental manuals, and all electrical schematic/interconnection drawings provided with the Load Bank prior to installation and operation.

Keep Away From Live Circuits

Operating and Maintenance personnel must at all times observe normal safety regulations. Do not replace components or make adjustments to equipment with power turned on. To avoid casualties, always remove power to the entire system. Turn off and disconnect the main-power source under test. Disconnect all sources of power to the Load Bank (Main input load bus, and 120 VAC control circuits).

Shock Hazard

Load Banks contain lethal voltages when connected to the power source. Power to the load resistors (main input load bus), and power to 120 VAC control circuits must be removed before servicing. Allow adequate time after removing power before servicing or touching any components. .

Do Not Service or Adjust Alone

Under no circumstances should any person reach into an enclosure for the purpose of service or adjustment of equipment except in the presence of someone who is capable of rendering aid.

Safety Earth Ground

An uninterruptible and approved earth ground must be supplied from the main power source. Serious injury or death can occur if this grounding is not properly supplied. Grounding of this equipment should be done by qualified personnel only and must be installed in accordance with all applicable national and local electrical codes and regulations.

Chemical Hazard

No chemicals are included in the manufacturing or operation of this unit. There are no chemical hazards to consider.

Emergency Aid

Personnel working with or near high voltages should be familiar with modern methods of resuscitation.

Potentially Hazardous Operator Conditions

- Read this manual prior to operation.
- Always run an approved ground conductor from the load bank frame to the power source under test which in turn must be properly earth grounded.
- Do not operate the unit unattended. Access to an approved electrical fire extinguisher should be on hand at all times.
- *Do not operate the Load Bank with access panels removed or doors open. Doing so would expose personnel to potential injury from electrical shock or from a moving fan blade.*
- Careful consideration needs to be taken during installation and equipment location during operation. Hot exhaust air can cause damage to other installed equipment. Do not direct hot exhaust air in the direction of other installed equipment.
- Do not allow hot-air exhaust to recirculate through the cold-air intake of the engine generator set or radiator air-intake cooling system.
- Do not allow objects to enter or block the cold-air intake or hot-air exhaust.
- The Load Bank must be installed and operated in a cool, well-ventilated area with adequate clearance.
- The unit should always be operated in a clean, cool, well-ventilated area free of dust and debris.

- Operating personnel should avoid and never come in contact with the hot-air exhaust and/or surrounding covers during operation and for some-time after operation as these surfaces become hot and may result in a serious burn injury.
- Never bypass any blown fuse.
- Replace any indicator lamps on the operator control panel as required. Each indicator is important to the protection of the unit and safety of the operator, and is an indication of proper system operation or failure.
- Do not bypass any safety circuit including exhaust over-temperature switch.
- Always short/shunt current transformer secondary circuits when troubleshooting metering and instrumentation circuits.
- Operating personnel should not come in contact with hot air exhaust opening, outside panels, system components, and load resistors for some time after operation.

A recommended 5 minute cool down period of the engine radiator cooling fan, with no load applied is recommended as best practice and will protect operating personnel from possible burn injuries. A 5 minute cool down should adequately remove any residual heat from the Load Bank and system components.

Emergency Shut-Down: The Emergency STOP pushbutton will immediately turn off control power to the load step application circuits, and control/instrumentation circuits. In a controlled emergency stop condition, turn the “Master Load” switch to the “OFF” position first. Turning the “Power On” switch to the “OFF” position will then turn off all control circuits. Turn off and disconnect the main-power source under test. Disconnect all sources of power to the Load Bank (Main input load bus, and 120 VAC control circuits).

Maintenance should always be done only by qualified personnel and with all sources of power disconnected from the unit (main input load bus power, power to all control circuits).

Always follow The National Electric Code (NEC), local electrical safety codes, and the Occupational Safety and Health Act (OSHA) when handling, installing, and operating equipment to reduce hazards, personal injury and property damage.

Cooling Airflow Installation Requirements

Radiator Duct mounted Load Banks do not have an integral cooling fan as stationary outdoor resistive load banks. The Load Bank requires customer supplied external cooling airflow. They must be installed to capture all of the cooling airflow from the engine radiator for cooling of the resistor load elements. Failure to directly couple the radiator duct flange opening (where all airflow is present), to the resistor duct opening during installation as to capture all of the cooling airflow from the engine radiator cooling fan will result in over-heating of the load resistors and terminal compartment, causing damage to load bank resistor elements and terminal compartment components, damage to the generator set, harm to personnel, and voids the warranty.

The resistor load elements require a continuous free flow of all the radiator cooling airflow and must be directly coupled to capture all of the radiator cooling airflow. The load resistors require a minimum of 1000 linear feet per minute (LFM) of continuous cooling airflow. The amount of adequate required cooling airflow must be verified prior to installation. Airflow of less than 1000 LFM will result in over-heating of the load resistors and terminal compartment causing damage to load bank resistor elements and terminal compartment components, damage to the generator set, harm to personnel, and voids the warranty.

The customer terminal connection and contactor side enclosure must be isolated from the coupling of the radiator cooling airflow to the resistors, and cannot obstruct radiator engine cooling airflow. The excessive heat from the radiator fan air will over-heat the side enclosure and cause damage to electrical components within the enclosure. In addition, the side enclosure cannot obstruct the radiator cooling airflow as it will add external static pressure as an obstruction to radiator engine cooling air and overheat the engine and cooling system.

Careful consideration must be given as to the amount of external static pressure drop the engine radiator cooling system can handle and must never be exceeded. The load bank will typically add between 0.125 to 0.50 inches of external static pressure drop to the cooling system (0.25 inches on average). For this reason, a radiator duct mounted load bank should only be used as a supplemental load to the generator set (as needed) and not exceed 50 percent of generator KW rating.

Radiator duct mounted load banks are intended to provide a supplemental load to the generator set (as needed) and not intended for continuous operation and 100 percent loading while coupled to the engine radiator as the resistor load elements cause heat rejection back to the radiator cooling system of the engine. They are also operated in a higher than normal raised ambient environment. If continuous operation, or operation at 100 percent load is required, it is recommended that a stationary outdoor load bank with its own integral cooling fan be considered which can be installed in a free field with a continuous flow of fresh ambient cooling air and not rely on the heated airflow from the engine radiator

Safety Symbols

WARNING

Warning notes call attention to a procedure, which if not correctly performed could result in personal injury.

CAUTION

Caution notes call attention to a procedure, which if not correctly performed could result in damage to the unit.



This symbol indicates that a shock hazard exists if the precautions in the instruction manual are not followed.



The caution symbol appears on the equipment indicating there is important information in the instruction manual regarding that particular area.



This symbol indicates that the unit radiates heat and should not be touched while hot.



NOTE: Calls attention to supplemental information.

Warning Statements

The following safety warnings appear in the text where there is danger to operating personnel. They are noted and repeated here for emphasis.

WARNING

Disconnect unit from all power sources before any disassembly or service.
Main input Load Bus, and 120 Volt AC control circuits.

WARNING

Do not insert a screwdriver or any thin metal objects through the perforated cooling air grilles while the load bank is in operation. The power within the unit could cause serious injury to personnel and damage to the unit.

WARNING

Do not remove the enclosure covers while unit is in operation or operate with covers removed. Unit will not properly cool without all covers in place and pose a shock hazard to personnel.

WARNING

Do not touch the enclosure surfaces while the unit is in operation. Enclosure surfaces are hot and exhaust temperatures can reach in excess of 400°F when unit is under load and in operation.

WARNING

Do not look into enclosure while in operation. Exhaust temperatures can reach temperatures in excess of 400°F when unit is under load and in operation. Dust and or debris may also be present.

WARNING

Do not position the exhaust to blow on other equipment or material susceptible to excessive heat. Never direct exhaust air towards flammable materials.

Caution Statements

The following equipment cautions appear in the text whenever the equipment is in danger of damage. They are noted and repeated here for emphasis.

CAUTION

Air enters from the engine generator radiator cooling fan cold-air intake side of the enclosure and exhausts at the opposite hot-air exhaust end of the enclosure. Blocking these openings will cause overheating and unit failure.

CAUTION

Do not apply more than the rated Voltage or exceed the power rating of the Load Bank. Excessive power will damage the internal resistor banks.

CAUTION

Confirm all control voltages before operation. Improper Voltage or Over-Voltage will damage load resistors, and control components.

CAUTION

Confirm that all load, and control connections are securely attached, turned, and tightened, and that the unit is properly grounded prior to operation. Failure to do so may result in equipment damage and harm to personnel.

CAUTION

Not using all mounting flanges will lessen mechanical integrity of the unit and may result in equipment damage, property damage, and/or harm to personnel.

Lingual General Safety Statements



USAGE: ANY USE OF THIS INSTRUMENT IN A MANNER NOT SPECIFIED BY THE MANUFACTURER MAY IMPAIR THE INSTRUMENTS SAFETY PROTECTION.

USO

EL USO DE ESTE INSTRUMENTO DE MANERA NO ESPECIFICADA POR EL FABRICANTE, PUEDE ANULAR LA PROTECCIÓN DE SEGURIDAD DEL INSTRUMENTO.

BENUTZUNG

WIRD DAS GERÄT AUF ANDERE WEISE VERWENDET ALS VOM HERSTELLER BESCHRIEBEN, KANN DIES GERÄTESICHERHEIT BEEINTRÄCHTIGT WERDEN.

UTILISATION

TOUTE UTILISATION DE CET INSTRUMENT QUI N'EST PAS EXPLICITEMENT PRÉVUE PAR LE FABRICANT PEUT ENDOMMAGER LE DISPOSITIF DE PROTECTION DE L'INSTRUMENT.

IMPIEGO

QUALORA QUESTO STRUMENTO VENISSE UTILIZZATO IN MODO DIVERSO DA COME SPECIFICATO DAL PRODUTTORE LA PROZIONE DI SICUREZZA POTREBBE VENIRNE COMPROMESSA.



SERVICE: SERVICING INSTRUCTIONS ARE FOR USE BY SERVICE - TRAINED PERSONNEL ONLY. TO AVOID DANGEROUS ELECTRIC SHOCK, DO NOT PERFORM ANY SERVICING UNLESS QUALIFIED TO DO SO.

SERVICIO

LAS INSTRUCCIONES DE SERVICIO SON PARA USO EXCLUSIVO DEL PERSONAL DE SERVICIO CAPACITADO. PARA EVITAR EL PELIGRO DE DESCARGAS ELÉCTRICAS, NO REALICE NINGÚN SERVICIO A MENOS QUE ESTÉ CAPACITADO PARA HACERLO.

WARTUNG

ANWEISUNGEN FÜR DIE WARTUNG DES GERÄTES GELTEN NUR FÜR GESCHULTES FACHPERSONAL. ZUR VERMEIDUNG GEFÄHRLICHE, ELEKTRISCHE SCHOCKS, SIND WARTUNGSARBEITEN AUSSCHLIEßLICH VON QUALIFIZIERTEM SERVICEPERSONAL DURCHZUFÜHREN.

ENTRETIEN

LE'EMPLOI DES INSTRUCTIONS D'ENTRETIEN DOIT ETRE RÉSERVÉ AU PERSONNEL FORMÉ AUX OPÉRATIONS D'ENTRETIEN. POUR PREVENIR UN CHOC ELECTRIQUE DANGEREUX NE PAS EFFECTUER D'ENTRETIEN SI L'ON N'A ÉTÉ QUALIFIÉ POUR CE FAIRE.

ASSISTENZA TECNICA

LE ISTRUZIONI RELATIVE ALL'ASSISTENZA SONO PREVISTE ESCLUSIVAMENTE PER IL PERSONALE OPPORTUNAMENTE ADDESTRATO. PER EVITARE PERICOLOSE SCOSSE ELETTRICHE NON EFFETTUARRE ALCUNA RIPARAZIONE A MENO CHE QUALIFICATI A FARLA.

Inspection and Unpacking

As part of your safety program, an initial inspection of all equipment should occur after receiving the unit. Periodic preventative maintenance and inspections should be performed to ensure system reliability.

Upon receipt of your Load Bank, be sure to carefully unpack the unit and inspect the unit carefully for any shipping damage. Check for loose, broken or otherwise damaged parts due to shipping. If damage is noticed, do not unpack the unit. Immediately notify Load Banks Direct LLC and report any shipping damage to the freight carrier.

Be sure to verify that the part number and ratings listed on the nameplate match the order specification. ***The ratings listed on the nameplate are critical – installing, operating, and energizing the incorrect part number could damage the unit and load resistors.***

If the unit is not damaged, unpack the equipment and remove protective stretch wrap. Remove all covers and inspect all of the components for visual signs of damage. Immediately notify the freight carrier and Load Banks Direct LLC of equipment damage or missing parts.

Reinstall packing materials for storage with exception of stretch wrap. **Do not store the unit with the protective plastic in place.**



NOTE: Do not reinstall or reapply protective stretch wrap. This material is meant for shipping protection only. Prolonged storage in stretch wrap may cause condensation damage to powder coat, painted, or mill galvanized finishes.

Product Overview

Load Banks Direct (LBD) LD Series of Radiator Duct Mounted Resistive Load Banks are designed for installation and operations “in line” with the engine radiator cooling fan. The enclosure is a Type-1 indoor open frame construction intended for direct mounting/coupling to the engine radiator. The load resistor opening is designed to match the opening of airflow available from the engine radiator fan cooling system. The Load Bank is an industrial power test unit specifically designed for mounting/coupling to engine radiator cooling systems for operation, and will absorb a balanced resistive load at unity power factor.

The Load Bank is a self-contained unit that includes an Operator Control Panel which allows the user to control and monitor individual-discrete load steps, control circuits, and safety circuits. Electrical energy from the power source under test is absorbed by the load bank resistors and converted into heat. The engine radiator cooling fan provides the necessary cooling airflow to cool the resistor load elements.

The Load Bank Unit contains all of the necessary principle system components for control and operation.

- **Load Circuits:** Including load power resistors, load step switching, branch circuit fuse protection, and main input load bus.
- **Cooling System:** Provided by engine radiator cooling fan.
- **Control Circuits:** Including 120 VAC controls, load application circuits, and indicators.
- **Automatic Load Dump Circuit:** Provides user interface provisions to disconnect and disable all load steps from a remote device.
- **Remote Indication and Alarm:** Provides user interface to building management system for indication and alarm of load bank safety circuits.
- **Safety Circuits:** Including branch circuit fuse protection for load power resistor circuits, fuse protection for control circuits, exhaust over temperature protection, load dump indication, and E-Stop.

CAUTION

The Load Bank should never be used without the Engine Radiator cooling fan in operation. Inadequate cooling airflow will result in resistor load elements overheating, fire hazard, and danger to personnel.

CAUTION

Never exceed the rated voltage of the unit as this will cause the Load Bank to overheat.

An Over Temperature switch is provided to monitor the temperature of the enclosure hot-air exhaust. If an over temperature condition is sensed, all load is removed.

Lower Voltages and variation in Frequency may be applied to the Resistor Load Bank load circuit (main input load bus). Frequency change causes no de-rating of the load. Application of lower voltages causes a de-rating of power (KW) from designed nameplate rating. The applied KW with a lower voltage is de-rated from its rated KW value. The actual applied KW when operated at a lower voltage is computed using the following formula:

$$kW_{\text{Applied}} = kW_{\text{Rated}} \times \frac{(\text{Voltage Applied})^2}{(\text{Voltage Rated})^2}$$

The Operator Control Panel provides the user control of the Load Bank. Main Power ON switch and indicator tell the operator control power circuits are energized and ready for operation. Load step application circuits include individual load step switching (one switch provided for each load step). Switched load steps (KW) are additive such that the desired amount of load can be achieved. The Master Load step switch allows a pre-selectable amount of load to be applied when the Master Load step switch is turned on.

Definitions and Formulas

KW = Kilowatts (Watts x 1000)

KVA = Kilo Volt Amperes

KVAR = Kilo Volt Amperes Reactive

PF = Power Factor

HP = Horse Power

BTU = British Thermal Unit

KW = KVA x PF

PF = KW / KVA

KVA = KW / PF

KVA = $\sqrt{KW^2 + KVAR^2}$

1 KW = 3412.14 BTU/Hour

$\sqrt{3}$ = 1.7321

1 HP = .746 KW

1 KW = 1.34 HP

Volts (L-L) is expressed as 3-phase System Voltage (Line to Line).

Amps is expressed as phase Amperes.

PF is expressed as Power Factor and is unity (1.0) in a Resistive Load Bank.

	<u>3 Phase</u>	<u>Single Phase</u>	<u>DC</u>
KW	$\frac{\text{Volts (L-L)} \times \text{Amps} \times \sqrt{3} \times \text{PF}}{1000}$	$\frac{\text{Volts} \times \text{Amps} \times \text{PF}}{1000}$	$\frac{\text{Volts} \times \text{Amps}}{1000}$
KVA	$\frac{\text{Volts (L-L)} \times \text{Amps} \times \sqrt{3}}{1000}$	$\frac{\text{Volts} \times \text{Amps}}{1000}$	
Amps	$\frac{\text{KW} \times 1000}{\text{Volts (L-L)} \times \sqrt{3} \times \text{PF}}$	$\frac{\text{KW} \times 1000}{\text{Volts} \times \text{PF}}$	$\frac{\text{KW} \times 1000}{\text{Volts}}$
Amps	$\frac{\text{KVA} \times 1000}{\text{Volts (L-L)} \times \sqrt{3}}$	$\frac{\text{KVA} \times 1000}{\text{Volts}}$	
HP	$\frac{\text{Volts (L-L)} \times \text{Amps} \times \sqrt{3} \times \text{PF}}{746}$	$\frac{\text{Volts} \times \text{Amps} \times \text{PF}}{746}$	

Theory of Operation

General

Load Banks are precision test and measurement instruments which are designed to provide discrete, selectable, resistive electrical loads for testing mission critical power sources. They can be effectively utilized for periodic maintenance testing of a back-up standby emergency generator.

Equipment Cooling

The power resistors used within the Load Bank are **LBD-PowerDyne™** resistor load elements situated within the “Resistor Assembly” (RA) frame. The resistor load elements are forced air cooled from the engine radiator cooling fan and designed for continuous operation at rated voltage. When the unit is in operation, the engine radiator cooling fan will force air across the entire resistor bank network. Hot-air exits the unit through the hot-air exhaust opening located at the opposite end of the unit.



WARNING

Do not look into enclosure exhaust while in operation. Exhaust temperatures can reach temperatures in excess of 400°F when unit is under load and in operation. Dust and or debris may also be present.

Load Banks Direct LD Series of Radiator Duct Mounted Resistive Load Banks are forced air-cooled, high powered units designed to be installed and operated indoors and must be securely attached to the engine radiator where the necessary cooling airflow is present. The highly efficient design provides a cost effective load testing solution featuring thermal monitoring over-temperature shut-down protection. Simple to operate, these units should provide years of operation yet are field repairable in the event of failure of a load resistor or other components.

Environmental Parameters

Wind Loading:	75 MPH
Seismic Zone Rating:	Zone 4
Ambient Temperature:	-20°F to +120°F
Altitude:	3,000 feet above sea level

- The equipment is intended for indoor installation and operation. The surrounding air must be free of contaminants or particles that could be drawn into the air intakes.
- The Resistor Load Bank Unit and resistors are fan forced-air cooled from the engine radiator cooling fan, have no intermediate dielectric fluids, and require no cooling water hookups.
- Careful consideration to surrounding equipment is required as hot-air exhaust temperatures can be in excess of 400°F when the unit is operated under full load.
- The unit should be placed in an open air environment where adequate space is available for air circulation. Do not enclose the unit in a small confined area with obstructions, or with nearby equipment in close proximity to the cold-air intake or hot-air exhaust. A minimum of 10-12 feet of clearance should be provided at hot-air exhaust. A minimum of 30 inches of clearance should be provided for equipment maintenance on each side of the enclosure. Never vent cold-air intake or hot-air exhaust. (Refer to Safety section of this manual).



WARNING

Do not touch the enclosure surfaces while the unit is in operation. Enclosure surfaces are hot and exhaust temperatures can reach in excess of 400°F when unit is under load and in operation.

Equipment Installation

Equipment Placement and Location

- Diligent care is required for proper installation of the Load Bank. The National Electric Code, all local installation codes, all electrical and safety codes, Occupational Safety and Health Act codes (OSHA) are required to be followed when installing this equipment to reduce any hazards to persons, personal property, and injury to any installation and operating personnel.
- Failure to follow installation guidelines will void the warranty.
- Installation, hook-up and operation should only be done by certified, qualified, licensed contractor technicians, which are trained and familiar with installation practice, operation of Load Banks and industrial electrical equipment.
- Prior to equipment placement and installation, inspect the Load Bank for any enclosure damage, broken wires, cracked or broken ceramic insulators, or any other component damage that may have occurred during shipment. Immediately report any damage claims to the freight carrier and contact the factory.
- Do not install the Load Bank where standing water can accumulate. Installation should be above grade.
- The open chassis resistor frame is equipped with top/bottom mounting flanges as well as removable (side) duct adapter flanges for direct mounting/coupling to the engine radiator cooling system. Careful consideration requires mounting such that airflow from the radiator fan is present to cool all **PowerDyne**™ resistor load elements.
- The Load Bank must be operated in a cool well ventilated open area where hot-air exhaust cannot be recirculated to the cold-air intake. Hot-air exhaust can exceed 400°F when operated under full load conditions.
- The open chassis frame when mounted/coupled to the engine radiator cooling system should be on a level and solid surface with a minimum clearance of 30 inches on each side of the enclosure for service and maintenance. A minimum of 10-12 feet of clearance at hot-air exhaust.
- The hot-air exhaust should blow to open air with no restrictions, redirection, or threat to personnel or other equipment.
- Never vent the cold-air intake or hot-air exhaust.



NOTE: Due to heat produced and generated during operation, careful consideration should always be taken when operated in close proximity to any other industrial equipment. Hot-air exhaust can damage temperature sensitive equipment up to 12 feet from hot-air exhaust.



NOTE: All clearances are recommended factory minimums. Clearances less than specified should be discussed with the factory prior to installation.

CAUTION

Air enters through the cold-air intake of the enclosure and exhausts at the hot-air exhaust at the opposite end of the enclosure. Blocking these openings will cause overheating and unit failure.



NOTE: The enclosure is designed to be carefully lifted from either the base or from the four (4) x 1.00" diameter holes located on the top 2" mounting flanges. A spreader bar may be necessary and required for a safe and adequate 4-point lift.



NOTE: To avoid damage to the enclosure and internal components, do not lift the enclosure in any manner with covers removed.

Equipment Mounting

There are four (4) x 1.00" diameter holes located on the top 2" mounting flanges designed to be utilized for an adequate 4-point lift when mounting. The top and bottom 2" mounting flanges and the removable side mounted duct adapter flanges are to be used to adequately mount and secure the load bank open chassis resistor frame to the engine radiator cooling system. After the enclosure frame is securely mounted, remove covers and ensure all packing materials and other debris are cleared. Re-install covers and torque bolts to 30 ft/lb.

CAUTION

Not using all mounting flanges when securing the open frame chassis enclosure to the engine radiator cooling system will lessen mechanical integrity and may result in equipment damage or harm to personnel.

Power Connection Considerations

Reference the Electrical Schematic and Electrical-Mechanical Ratings section of this manual for the Total Power Ratings of; Main Input Load Bus (KW, Voltage, Phase, Frequency), and Control Circuit Ratings.

Load cable conductors from the power source to the load bank should be adequately sized and protected to handle the maximum rated load, and in accordance to the National Electric Code and any local codes.

In order to adequately protect the conductors to the Load Bank, an approved, lockable, and properly sized main circuit breaker and/or disconnect switch should be mounted as close to the power source as possible. Always refer and adhere to National Electric Code and any local codes.

Power Connection Access

Bottom access area provisions are provided for entry of load cable from power source under test to main input load bus terminals. The contactor/relay terminal compartment provides access to main input load bus bars, and 120 Volt AC control circuits.

Main Input Load Bus Power Connections

Reference the Electrical Schematic/Interconnection drawing, and Electrical- Mechanical Ratings section of this manual for the Total Power Ratings of; Main Input Load Bus, and 120 VAC Control Circuit

The Load Bank has three main input load bus bars (marked A, B, C). Load cable connections are made directly to the respective bus bars or directly to a Power Distribution Block (PD1). Bus Bars have provisions provided for suitable mounting of load cable using ½” hardware. A standard NEMA 2-hole pattern is provided on each respective bus bar for phase-A, phase-B, and phase- C.

Load cable conductors from the power source to the load bank should be adequately sized and protected to handle the maximum rated load, and in accordance to the National Electric Code and any local codes.

In order to adequately protect the conductors to the Load Bank, an approved, lockable, and properly sized main circuit breaker and/or disconnect switch should be mounted as close to the power source as possible. Always refer and adhere to National Electric Code and any local codes.

Verify that load cables, lugs, and mounting hardware connections have sufficient clearance to the surrounding sheet metal enclosure, control components, phase- phase clearance, and phase to enclosure chassis clearance and cover, prior to securing the cover panel in place and sealing the enclosure.



NOTE: After all load power cable is connected to the respective main input load bus bars (A, B, C), use torque wrench to ensure all termination hardware is properly tightened.

Grounding

An uninterruptible and approved earth ground must be supplied from the main power source which in turn must be connected to a solid earth ground. Serious injury or death can occur if this grounding is not properly supplied. Grounding of this equipment should be done by qualified personnel only and must be installed in accordance with all applicable National Electric Code, local electrical codes, and regulations.

Permanent ground conductors must be sized and connected to the Load Bank enclosure per the National Electric Code and any local codes. Adequately and permanently ground the open chassis resistor frame with an approved earth ground conductor attached to the resistor frame which is in turn, connected to solid earth ground.

Control Power Circuit, and Control Power Transformer Circuit

External Control Power connections are made directly to terminal block TB1. Three (3) connections are noted and required (High – Low – Ground).

- Reference detailed Electrical Schematic and Interconnection drawing for external control power terminal block connection points, and power rating requirements.
- Reference Control Power Circuit Ratings in the Electrical and Mechanical Ratings section of this manual for control power rating requirements.

Control Power Circuit: When wired to an external power source, safe practice dictates that the 120 Volt AC, 1-phase 60 Hertz supply power to the control power circuit is wired through an approved lockable safety disconnect switch. Control Power requirements are noted on the Electrical Schematic and Interconnection drawing supplied with this manual and also noted in the Electrical and Mechanical Ratings section of this manual. Control Power circuit conductors, supply voltage, and load service amperage should be adequately sized and protected to handle the maximum rated load according to the National Electric Code and any local codes.

Control Power Transformer: If the Load Bank is supplied with a 120 VAC Control Power Transformer, no additional wiring for control circuit operation is required. The 120 VAC 1-phase Control Power Transformer will come factory sized and wired to adequately provide the necessary power requirements to run the Load Bank control circuits. Control Power Transformer is both primary and secondary fuse protected, and is factory wired to derive power from 2-phases of the main input load bus.



CAUTION

Confirm all bus bar connections to main input load bus and ground connections are properly tightened to required torque values. Confirm all external control power connections, and all customer interconnection wiring between Load Bank and Operator Control Unit are properly crimped and tightened to required torque values. Loose connections will result in equipment damage and danger to personnel.



WARNING

Loose terminal connections may promote arcing to the enclosure posing a shock hazard. Never connect powered control leads to a terminal block as it may result in component damage or pose a shock hazard to personnel.

Operator Controls

The Load Bank is supplied with an Operator Control Panel which is used for control and monitor of the Load Bank control circuits, load application circuits, and safety circuits.

If operator control panel is provided in a separate remote enclosure, interconnection to Load Bank is by *point-point* wiring between Operator Control unit and Load Bank (from terminal block TB1 on Operator Control Unit to terminal block TB1 on the Load Bank) as shown on the Electrical Schematic and Interconnection drawing.

- Reference detailed Electrical Schematic and Interconnection drawing for point-point interconnection and terminal block connection points between Operator Control Panel TB1, and Load Bank TB1.
- Adequately size the interconnection conductors in accordance with the control power circuit power ratings and taking into consideration any potential voltage drops in the installed distance between Operator Control unit and Load Bank unit.
- To minimize Voltage drop, it is recommended that interconnection control wiring be minimum 14 AWG for interconnection wire run lengths under 50 feet. Select control interconnection wire size and type in accordance to the National Electric Code and local codes.
- Always check the mechanical integrity of all interconnection wiring and that lugs are properly crimped and terminations properly torqued.
- Always use Electrical Schematic and Interconnection drawing to verify, check, and ohm out all customer supplied interconnection and control wiring.

Automatic Load Dump Circuit: Provides user interface provisions to the generator controls, automatic transfer switch, or building management system, to disconnect and disable all load steps from a normally closed (NC) set of auxiliary contacts from the automatic transfer switch (ATS) or other remote device. In the event of utility loss during a regularly scheduled load test on the standby emergency power source, all load bank load is removed from the source under test.

Remote Indication and Alarm: Provides user interface contact closure [form-c-type normally open and normally closed] to building management systems for indication, detection, and alarm of “Over-Temperature” and “Load Dump”.

- Reference Electrical Schematic and Interconnection drawing for terminal block wiring location of optional Automatic Load Dump and remote indication/alarm circuits

Multi-Power Meter

If the Load Bank Operator Control unit is supplied with a multi-function Multi-Power Meter Display, meter input wiring for Voltage and Current is located within the Load Bank. With the Load Bank in operation and under load, the Multi-Power Meter allows the operator to monitor, measure, display, and record electrical load parameters such as 3-Phase System Volts, Phase Amperage, Frequency, and Power Functions.

- Voltage inputs are sensed from the main input load bus and are fuse protected, wired direct to the meter by interconnection of Operator Control Panel.
- Current Transformers sense primary phase current. Secondary connections are made direct to the meter by interconnection of Operator Control Panel.
- Reference Electrical Schematic and Interconnection drawing for exact terminal block locations numbers of all point-point interconnection wiring of metering circuit.



Note: The Load Bank may be shipped with jumper wires installed across the current transformer secondary for protection. These jumper wires must not be removed until after interconnection of Load Bank and Operator Control Unit is complete. Always short/shunt current transformer secondary circuits when servicing or troubleshooting metering and instrumentation circuits. Primary current flowing through an un-shunted open secondary of a current transformer will destroy the current transformer with possible danger and harm to personnel.



Note: Complete details, functions, and operation of the Multi-Power Meter are described in the supplemental Multi-Power Meter Quick Start Guide supplied as part of the Appendix of this Load Bank Manual.

CAUTION

Confirm all external control voltages before operation. Over or under voltage will damage control components.



CAUTION

Confirm all main input load bus and ground connections are properly connected, turned, and tightened. Confirm external control power connections. Loose connections will result in damage and danger to personnel.

Automatic Load-Level Option

If the Load Bank is equipped with the Automatic Load Level Control option, the unit is shipped with a separately supplied current transformer CT100 that must be installed and wired as shown on the Electrical Schematic and Interconnection diagram.

Theory of Operation

The Automatic Load Controller senses the downstream connected building load and upon “Transfer of Control” contact closure, will add/subtract Load Bank load steps in response to downstream building load changes as to provide a minimum load on the power source. With the Load Bank in operation in the Automatic mode, the controller will continue to add/subtract load in response to the dynamic power fluctuations of the connected building load. The controller utilizes the load bank as a “supplemental load” for maintaining a minimum load on the power source.

When the Operator Control panel Manual/Auto switch is in the “Auto” position, the customer supplied “Transfer of Control” contact closure will initiate the Load Bank controls, initiate the load application circuit, and begin sensing the downstream connected building load. The separately supplied current transformer CT100 provides the necessary feedback signal for sensing the downstream connected building load. After an initial Time Delay, the controller begins adding/removing load steps accordingly as to keep a minimum load on the power source.

Customer supplied “Transfer of Control” contacts and separately supplied current transformer CT connections are to be wired to the respective load bank terminal block location terminals as noted on the Electrical Schematic/Interconnection Diagram.

 **The Load Bank is shipped with a separately supplied current transformer that must be mounted as shown in a location as to sense the downstream building load connected to the power source.**

 Always short/shunt current transformer secondary circuits when servicing or troubleshooting current transformer sensing and/or instrumentation circuits. Primary current flowing through an un-shunted open secondary of a current transformer will destroy the current transformer with possible danger and harm to personnel

IMPORTANT: CT100 must be installed between the Load Bank and Building Load as shown on page 2 of Electrical Schematic/Interconnection diagram. Installing CT100 between Load Bank and Generator will cause Load Bank failure and Void Warranty.

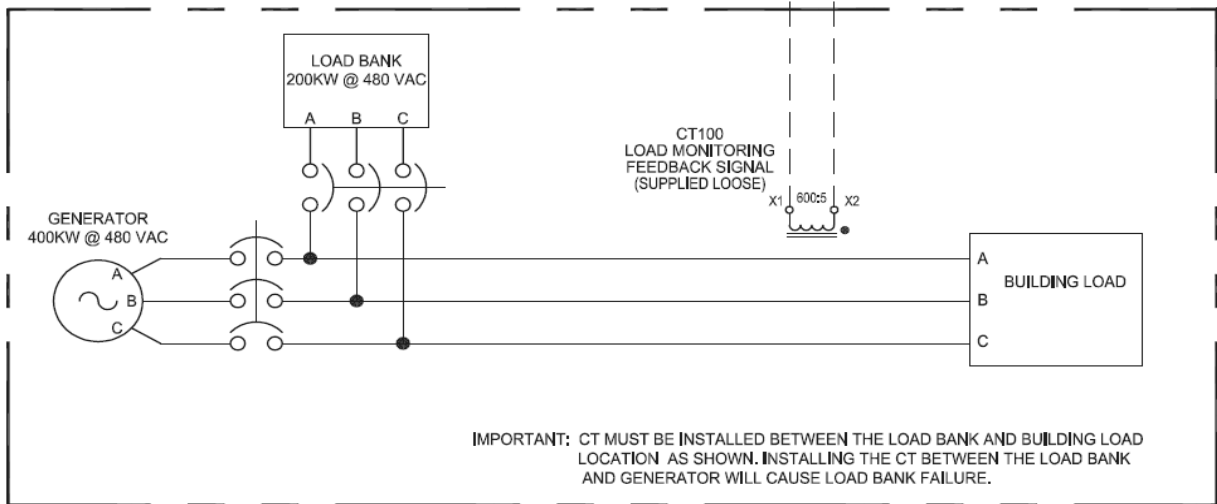

Automatic Control System features when included with Reverse Power Relays

K-VCR - Initial Generator Voltage Sensing Relay. Forward Power mode applies load bank load to the generator in three (3) stages as to maintain a minimum load on the power source. The first two (2) steps of load are applied on a time delay basis with 0 KW downstream connected load and are programmed to drop out steps as the downstream (connected building load) rises above the pre-programmed set-points. Stages 3 and 4 connect and apply load upon detection of reverse power (set to apply steps respectively upon detection of reverse power at approximately 4 percent and 10 percent of generator KW rating). Stages 1 and 2 are added and bypassed (if not already applied on a time delay basis) if reverse power continues to rise above 20 percent of generator KW rating.

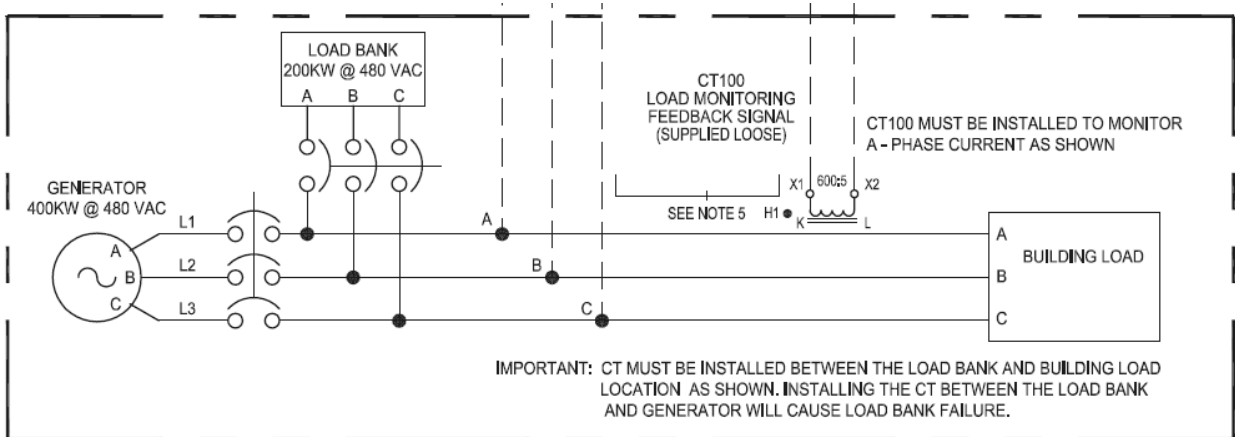

NOTES:

5) PROPER PHASING MUST BE OBSERVED WHEN MAKING 3 PHASE VOLTAGE CONNECTIONS L1-PHASE A TO TB100(1), L2-PHASE B TO TB100(2), L3-PHASE C TO TB100(3). PROPER PHASING MUST BE OBSERVED WHEN MAKING CT100 CONNECTIONS X1 TO TB100(5) AND X2 TO TB100(6).

REFERENCE DOT "•" OR H1 MARKING MUST ALWAYS FACE THE POWER SOURCE.

NO WIRE CODE.

Operating Instructions

General

- All installation should be reviewed and checked by a qualified technician with all local and National Electric codes observed.
- Ensure all connections are properly tightened and all covers are installed.
- Never operate the unit un-attended.
- All wiring from external power sources to Load Bank Unit (including; main input load bus, and 120 VAC control circuits) should be verified and checked by a qualified technician with all local and National Electric codes observed.
- All interconnection wiring of Operator Control Unit and Load Bank should be verified and checked by a qualified technician with all local and National Electric Codes observed.
- The following Cautions and Warnings should be strictly enforced:



CAUTION

Operation of the unit with any covers removed may disrupt air flow and allow debris to pass through controls possibly damaging equipment.



WARNING

Operation of the unit with any covers removed will pose a shock hazard and danger to personnel.



WARNING

Do not look into the exhaust of the enclosure while in operation. Exhaust temperatures can reach temperatures in excess of 500°F when unit is under load and in operation. Dust and or debris may also be present.



WARNING

Do not touch the enclosure surfaces while the unit is in operation. Enclosure surfaces are hot and exhaust temperatures can reach in excess of 400°F when unit is under load and in operation.



WARNING

Do not insert a screwdriver or any thin metal objects through the perforated cooling air grilles while the load is in operation. The power within the unit could arc over and will cause serious injury to personnel and damage to the unit.



WARNING

Do not operate under load without cooling from radiator fan. Immediate equipment damage may result.

Operation

- Connect the power source under test to main input load bus as described in the Installation section of this manual.
- Verify – Check Emergency Stop Button is in the “Closed” operating position
- With Operator control panel switches in the OFF position, place Control Power switch to the ON position (control power on indicator will illuminate).
- **Note:** Ensure and check for proper direction of airflow from cold-air intake to hot-air exhaust.

CAUTION

DO NOT operate the Load Bank over rated nameplate Voltage as this will cause catastrophic failure.

The operation of the radiator cooling fan is critical for safe operation. If the over-temp lamp is illuminated, all load steps are disabled and load cannot be applied.

DO NOT attempt to bypass the over-temperature switch as this will cause catastrophic damage to the unit.

- With Master Load and KW load step switches in the OFF position, pre-select a KW load using one or any additive combination of load step increments by turning the switches to the ON position.
- Turning the Master Load step switch to the ON position, the pre-selected amount of load KW will be applied to the power source under test.
- Any available combination of incremental KW load values can be turned ON/OFF during operation to achieve the desired load on the power source under test.
- **Shut-Down:** Turn the “Master Load” switch, and all load step switches to the “OFF” position first (allowing radiator fan to run while all load steps are disconnected). Turning the “Power On” switch to the “OFF” position will turn off all control power circuits. Turn off and disconnect the main-power source under test. Disconnect all sources of power to the Load Bank (Main input load bus, and 120 VAC control circuits).

- A recommended 5 minute cool down period of the radiator fan running with no load applied, should adequately remove any residual heat from the Load Bank and system components.

WARNING

**DO NOT touch the exhaust during operation.
Hot-Air exhaust will cause serious burns.
DO NOT allow objects to enter or block air intake or
exhaust.
DO NOT operate the Load Bank over rated
nameplate Voltage as this will cause catastrophic
failure and danger to personnel.
DO NOT apply DC voltages to main input load bus.
Refer to Safety section of this manual**

Safety and Shut-Down Indicators

- “Emergency Stop” Pushbutton disables 120 VAC control power to all control circuits (load application circuit, instrumentation, control and safety circuits)
- “Over-Temperature” indicates an exhaust over-temp condition (all load is removed).
- “Load Dump” indicates removal of all loads due to one or all of the above conditions

Maintenance

Maintenance personnel must always exercise caution when access panels are removed. Personal injury from electrical shock or from moving fan blades could result unless all sources of power are completely disconnected before servicing. Maintenance must always be done by qualified technician.

Maintenance procedures must be followed to provide longevity of equipment life, and to reduce the probability of electric shock hazard, fire, personal injury, or property damage.

Before servicing this equipment, completely review the “**Safety Points**” and “**Potentially Hazardous Operator Conditions**” sections of this manual. Maintenance must always be done by a qualified and certified technician. Proper protective arch-flash clothing, eye protection, ear protection, gloves, and hard-hat should be worn when servicing or maintaining the unit.



WARNING

Disconnect from all sources of power to the unit (Main input Load Bus, External Control Power) prior to any inspection, service, or cleaning.
Electric Shock Hazard exists while connected.

For optimum performance and service life, preventative maintenance is a key factor. It is recommended that during scheduled inactiveness, reactivation from storage, or unit relocation the following maintenance steps are performed:

Daily Maintenance Prior to Operation

1. Inspect and remove any restrictions and/or obstructions to cold-air intake and hot-air exhaust of the Load Bank unit.
2. Check intake and exhaust to make sure objects have not blocked/entered resistor frame.
3. Verify the direction of the airflow is in the proper direction from cold-air intake to hot-air exhaust.
4. Verify that there is no possibility of re-circulation of hot-air exhaust to cold-air intake.

Quarterly Maintenance (every three months)

1. Remove all exterior access panels to Load Bank enclosure (including air intake and exhaust covers).
2. Inspect the intake and exhaust openings. Blow or brush away any noticeable dirt or debris. Ensure covers are functional and free of debris. Replace any respective panel that is compromised or damaged.
3. Clean any and all dirt and/or debris from the interior of the entire Load Bank. Do not exceed 40 PSI when using clean, dry, compressed air for blowing and removing dust and debris.
4. Inspect all resistor elements ensuring all hardware is tightened and elements are clear and free of debris.
5. Inspect all resistors for mechanical and structural integrity and location. Replace any excessive sagging resistor elements, ceramics and support rods. Replace any and all broken or cracked termination ceramics, and ceramics on resistor support rods as required.
6. Inspect all termination ceramic insulators at resistor case ends (both sides) for breaks or cracks and replace as necessary.
7. Inspect all support rod ceramic insulators for breaks or cracks and replace as necessary.
8. Inspect the entire inside of the enclosure for loose hardware or loose connections and tighten to proper torque values as required.
9. Inspect all load and control wiring for signs of insulation failure or breakdown.
10. Inspect for any signs of heat stress on connections and terminals. This could be a sign of loose hardware or corroded/oxidized connections. Repair and replace connection hardware as required.
11. Inspect all electrical connections to terminal blocks, main input load bus bars, fuses mounted to bus bars, all resistor connections for corrosion and oxidation. Clean connections and replace hardware as required. Tighten as necessary.
12. Inspect all load step contactors. Inspect magnetic contactor coils for oxidation and rust. Inspect contacts that carry load if pitted, rusted or corroded. Contacts must all move freely and properly seal when closed. Replace as necessary.
13. When replacing current transformers, mark all leads before removing to ensure proper phasing of new current transformer. Never leave the secondary of a current transformer un-shunted.
14. Reinstall all covers ensuring all materials are well in place and all hardware is properly tightened.
15. Check all indicator lamps on Operator Control unit (replace as necessary).



CAUTION

Do not pressure wash the inside component terminal compartment (relay panel) as damage may occur to electro-mechanical load step relays, and control circuits, safety circuits, and terminal strip wiring. If splashed, ensure entire compartment is dry before covering.



WARNING

Pressure washing terminal compartment (relay panel) may lead to condensation and promote internal arcing.

Additional Preventative Maintenance Measures (as required)

1. The outside surface of the unit should be wiped or blown free of dust and dirt. Careful consideration to controls, metering and relay compartment must be taken into account when pressure washing the exterior of the enclosure. Ensure air intake and exhaust areas are clean and debris free. Blast or sand any noticeable corrosion areas and cover with a suitable paint or coating.
2. Remove both side access panels and ensure all resistor terminal connections including wire, bus jumper, and bushings are tightened to 50 ft/lb. Inspect all ceramic bushings and insulators for cracks. Replace all broken or cracked ceramic insulators. Ensure all fan and safety component connections are tight. If required, it is safe to blow any dust from this compartment using 40 PSI or less of clean, dry, compressed air. Replace any broken or failed components. Reinstall access panel cover before proceeding with any enclosure maintenance.
3. If resistor elements are extremely dirty, elements can be pressure washed. Pressures up to 400 PSI at a distance of two feet or greater may be used when cleaning the resistor elements. Pressure should be reduced for the connection points and the distance from the nozzle to any insulator should not be closer than four feet to prevent damage.

Troubleshooting Guide

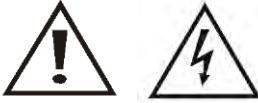

WARNING

Disconnect all sources of power to the unit (Main input Load Bus, External Control Power) prior to any inspection, service, or cleaning. Electric Shock Hazard exists while connected.

For corrections requiring repair or replacement of components, contact the factory immediately for further instruction. Only those functions within the scope of normal maintenance are listed. This manual cannot list all malfunctions that may occur, or corrective actions. If a malfunction is not listed or is not corrected by listed corrective actions, notify the factory.

 **Note:** When checking fuses for continuity, remove all fuses from fuse blocks, bus bars, fuse holders, and disconnect switch. Test each fuse individually and out of circuit. A blown fuse left in the circuit may check out OK with false reading of continuity due to feedback and return paths within the circuit

1) No Main Power to 120 VAC Control Circuits

- Emergency Stop / “E-STOP” push button is in the open position.
- Terminals damaged during shipment.
- External Control Power Main Switch or circuit breaker is not closed.
- Control Power Transformer failure (primary or secondary control power fuse is blown (check and replace as required).
- Control Circuit Fuse is blown (check and replace as required).
- Dirty or loose connections or faulty Main Power Switch.

2) Over-Temp Lamp Illuminated

- Obstruction/restriction of air flow at Load Bank air intake or hot-air exhaust.
- Direction of cooling airflow is incorrect causing over-heating of resistor load elements.
- Restricted cooling airflow - indicating a loss of cooling airflow. Sign of resistor over-temperature. Verify and ensure air intake and exhaust openings are clear of any debris, blockage or obstruction.
- Over-Temp switch or Over-Temp auxiliary relay is malfunctioning or not operating correctly.

3) Load Dump Lamp Illuminated

- Indication that all load steps are removed due to Over-Temp or open customer remote load dump contact.

4) Resistor Open or Phase Imbalance

- Blown load step fuse in branch load circuit (check and replace as necessary).
- Loose bus bar or loose connection at resistor terminal or fuse (tighten all bus bar and connection points as required).
- Resistor element failure and burned open (replace as necessary).

5) Load Step or Load step application circuit cannot be energized

- Emergency Stop / "E-STOP" push button is in the open position.
- Over-Temp, or Load Dump, (see item 2 or 3 above).
- Master Load Step switch is in the OFF position or not functioning.
- Load Step toggle switch is inoperative.
- One or more of the branch circuit load step fuses for the load step in question is blown (check and replace as necessary).
- One or more of the load step resistor for the load step in question has failed or burned open (check and replace as necessary).
- Load step contactor failed or inoperative. Loose connection, failed/open coil.

6) Load Step energized without rated load, or un-balanced load

- Applied main input bus voltage from power source under test is de-rated, low, imbalanced or inadequate.
- Contactor failure or not closing properly. Loose connection.
- One or more of the branch circuit load step fuses for the load step in question is blown (check and replace as necessary).
- One or more of the load step resistor for the load step in question has failed or burned open (check and replace as necessary).

7) Load Step contactor or relay chattering

- Contacts are pitted or oxidized.
- Magnetic core and coil are dirty or corroded.
- Coil connections to the contactor are loose.
- 120 VAC control circuit line voltage is low and/or inadequate.

8) Switchgear Circuit Breaker trips or Main Disconnect fuses are blown

- Fuses and/or circuit breaker trip settings are undersized.
- A short circuit exists at the Load Bank Resistor (main input load bus).
- A short exists in the power conductors feeding the Load Bank Resistor.

 **Note:** When checking fuses for continuity, remove all fuses from fuse blocks, bus bars, fuse holders, and disconnect switch. Test each fuse individually and out of circuit. A blown fuse left in the circuit may check out OK with false reading of continuity due to feedback and return paths within the circuit

Storage

- It is recommended that the unit be stored indoors in a dry enclosed area. There is no special preparation required.
- If the unit is to be unused or stored for any length of time indoors, cover the unit to prevent any accumulation or buildup of dust or dirt. If stored outdoors, do not cover with plastic that may create condensation and enclosure corrosion or staining (keep exhaust hood in place).
- Storage temperatures should remain -22°F to +122°F [- 30°C to +50°C]

Shipping

- Attach the enclosure to a skid constructed with minimum board thickness of two inches (2") to properly support the unit's weight. Use (4) or more lag bolts in the mounting base holes provided at the entrance to the integrated fork lift tine receptacles, and properly secure the load bank to the mounting skid.
- Secure all loose parts in the bottom of the enclosure and reinstall cover.
- Pack, seal securely in a sturdy wooden crate or equivalent, with sufficient padding to avoid shock damage.
- Ship Operator Control Unit separately.
- If returning to the factory, a factory Return Merchandise Authorization (RMA) Number will be required prior to shipment or may be refused at the dock.

Customer Service

Any maintenance or service procedure beyond scope of those provided in this manual should be referred to a factory engineer. All units returned for service must be shipped prepaid and to the attention of the factory engineer in which return and service were discussed with RMA number noted.

Contact Information

Load Banks Direct LLC
125 West 34th Street
Covington, KY 41015
U.S.A.

Toll Free: 855-LBD-CALL (855-523-2255)
Fax: 859-554-2530

Email: cs@LoadBanksDirect.com

Website: www.LoadBanksDirect.com



Warranty

LOAD BANKS DIRECT LOAD BANKS PRODUCTS: The Company warrants title to the product(s) and, except as noted below with respect to items not bearing the Load Banks Direct load banks brand, also warrants the product(s) on date of shipment to Purchaser, to be of the kind and quality described, merchantable, and free of defects in workmanship and material. THIS WARRANTY IS EXPRESSLY IN LIEU OF ALL OTHER WARRANTIES FROM THE COMPANY OR THE MANUFACTURER, INCLUDING BUT NOT LIMITED TO IMPLIED WARRANTIES OF MERCHANTABILITY AND FITNESS, AND CONSTITUTES THE ONLY WARRANTY WITH RESPECT TO THE PRODUCT(S) AND NO OTHER WARRANTY IS GIVEN WHICH EXTENDS BEYOND THE DESCRIPTION ON THE FACE OF THE COMPANY'S QUOTATION OR ACCEPTANCE FORM. This warranty shall remain in effect for a period of one (1) year from date of initial operation or eighteen (18) months from date of shipment, whichever is earlier. This warranty shall be null and void if Purchaser makes any alterations, additions, modifications or improvements to the product(s).

DISCLAIMER OF WARRANTY, OTHER PRODUCTS: ANY SEPARATELY LISTED ITEM OF THE PRODUCT(S) WHICH IS NOT A LOAD BANKS DIRECT LOAD BANKS BRANDED PRODUCT IS NOT WARRANTED BY THE COMPANY, and shall be covered only by the express warranty, if any, of the manufacturer thereof. As between Purchaser and the Company, such products are sold AS IS, and Company makes no warranties, express or implied, as to any matter whatsoever, including, without limitation, THE CONDITION OF THE EQUIPMENT, ITS MERCHANTABILITY, ITS DESIGN, ITS CAPACITY, ITS PERFORMANCE, ITS MATERIAL, ITS WORKMANSHIP, AND ITS FITNESS FOR ANY PARTICULAR PURPOSE. COMPANY DISCLAIMS ANY LIABILITY WHATSOEVER FOR LOSS, DAMAGE, OR INJURY TO PURCHASER OR THIRD PARTIES AS A RESULT OF ANY DEFECTS, LATENT OR OTHERWISE, IN A PRODUCT NOT MANUFACTURED BY COMPANY, AND COMPANY SHALL NOT BE LIABLE IN ANY EVENT FOR ANY LOSS, DELAY, OR DAMAGE OF ANY KIND OR CHARACTER RESULTING FROM DEFECTS IN, OR INEFFICIENCY OF, PRODUCTS NOT MANUFACTURED BY LOAD BANKS DIRECT. NO OTHER WARRANTY IS GIVEN EXTENDING BEYOND THE DESCRIPTION ON THE FACE OF THE COMPANY'S QUOTATION OR ACCEPTANCE FORM. The Company will in respect of such goods use reasonable efforts to pass on to the Purchaser the benefit of any guarantee provided by the manufacturer or supplier of such goods but not so as to impose on the Company any liability in respect thereof.

Electrical and Mechanical Ratings

Always refer to the Load Bank Nameplate and Electrical Schematic / Interconnection Diagram included with this manual for specific rating information.

Dedicated Part Numbering System includes Electrical Power Rating (KW), Voltage, Resolution (KW), Options, and Core Dimensions [Width x Height].

PART NUMBERING SYSTEM

LD- _____ (KW) - _____ (VOLTS) - _____ (RESOLUTION) - ____ (OPTIONS) - _____ [CORE WIDTH x HEIGHT]

Type LD = Load Bank, Duct Mount
 Power Rating= KW rating of Load Bank
 Voltage = System Voltage Rating (208, 240, 480, 600 VAC)
 Resolution = Minimum load step resolution – [25 or 50 KW]

Accessory Options [A] Automatic Load Step Controller
 [T] Control Power Transformer
 [R] Remote Operator Control Unit

EXAMPLE: **LD100-480-25-AT-46-48**

DESCRIPTION: Radiator Duct Mounted Load Bank Rated 100 KW, at 480 Volts AC, 25 KW Load Step Resolution, with Automatic Load Step Controller and Control Power Transformer. Core Size = 46” Wide x 48” High

LD 100 KW Example Part Numbers	Power Rating (KW)	Voltage (Volts AC)	Amps per phase	Load Step Resolution (KW)
LD100-208-25	100	208	278	25
LD100-480-25	100	480	120	25
LD100-600-25	100	600	96	25

$$\text{Amps per Phase} = \frac{\text{KW} \times 1000}{\text{Volts (L-L)} \times \sqrt{3} \times \text{PF}} \quad \text{or} \quad \frac{\text{KW} \times 577}{\text{Volts (L-L)}}$$

Single Phase Operation: Power Rating (KW), will de-rate by 50% when operated phase-phase at rated single phase voltages, and will provide up to 66% of rated load when single phase voltages are applied across all three phases.

Control Power Circuit Ratings: 120 Volts AC, 1-phase, 60 Hertz, 10 Amps

Operating Temperature: -20°F to +120°F [-29°C to +49°C]

Approximate Enclosure Dimensions:

Width (Inches) = Core Width + 18 Inches
 Height (Inches) = Core Height + 4 Inches
 Depth (Inches) = 16 Inches

Specifications

Type: Duct Mount Resistive Load Bank, Unity (1.0) Power Factor.

Duty Cycle: Forced Air-Cooled by Engine Radiator Cooling Fan, rated for continuous operation.

Cooling System: The load bank is directly mounted “In-Line” with the Engine Radiator Cooling Fan which delivers the required airflow volume (CFM) for cooling resistor load elements.

Control Power: External 120 Volt AC, 1-phase, 60 Hertz, 10 Amp source.

Operator Control Panel: Emergency Stop (E-Stop) push button, Main Power On/Off switch, Master Load On/Off switch and individual Load Step Switches (KW On/Off) provided for each load step. Illuminated indicators provided for Power On, Over-Temperature, and Load Dump.

Automatic Load Dump circuit provides user interface provisions to the generator controls, automatic transfer switch, or building management system, to disconnect and disable all load steps from a normally closed (NC) set of auxiliary contacts. In the event of an actual power failure, all load bank load is removed from the source under test.

Remote Indication and Alarm contact closure [form-c-type normally open and normally closed] provides user interface to building management system for indication, detection, and alarm of “Air-Flow Failure”, “Over-Temperature”, and “Load Dump”.

Operator Protection and Safety Features:

- A Control Power Emergency-Stop (E-STOP) push button is provided to disable control power voltage to all operator control power circuits, including load application circuits.
- Operator control panel provides detection and display of Main Power On, Over-Temperature, and Load Dump.
- Branch circuit fuse protection provides short-circuit fault protection of all load steps. Fuses are fast-acting, current-limiting type with an interrupting rating of 200K A.I.C.
- An over-temperature switch is provided to monitor load bank exhaust temperature. The switch automatically removes all load if an over-temperature condition is detected. Load cannot be reapplied until the over-temperature condition is corrected.
- Operator warning and caution statements are located on appropriate access panels.

LBD-PowerDyne™ Resistor load elements provide the necessary KW load rating for each load step. PowerDyne™ Resistors are fully supported across their entire length within the air stream by stainless steel support rods which are insulated with heavy-duty, high-temperature ceramic insulators. Change in resistance is minimized by maintaining conservative resistor designs.

Load Bank Construction and Power Connections:

- The load bank enclosure is an open resistor frame of galvanized steel construction for direct mounting/coupling to the engine radiator.
- The load bank is designed for installation and operation indoors or within the generator set housing with sufficient fresh intake air available.
- The galvanized steel open frame provides a 2” top and bottom mounting flange as well as removable side duct adapter flanges for direct mounting/coupling to the engine radiator or exhaust duct. Load Bank resistor frame opening is designed to match the opening of airflow available from the engine radiator cooling system.
- All power connections including main-input load, external control power, operator controls, instrumentation, and customer interface connections are made within the enclosed relay/connection compartment.

Application Note: Radiator Duct Mounted Load Banks are designed to be used as a supplemental load to the generator set - sized at ~50% of generator KW rating. Exact Radiator Core Dimensions (radiator opening), and cooling airflow volume (CFM) are required.

[Letter] Denotes Accessory Option

[Add letter designator to end of the load bank part number]

[A] - The Automatic Load Level Controller will add/subtract load bank load in response to dynamic power fluctuations of the connected building load. It utilizes the load bank as a “supplemental load” for maintaining a minimum load on the power source. Customer “transfer of control” contact closure initiates the load bank and time delay load application circuit. A separately supplied current transformer provides the necessary feedback signal for sensing building load.

[T] - Control Power Transformer delivers the necessary 120 Volt AC, 1-phase, 60 Hertz power required for control circuit operation. Control power transformer is wired to blower motor circuit and is primary and secondary fuse protected. Required only if 120 VAC control power is not readily available.

Parts List

The parts list in this section contains the description and part number of the typical parts used in each of the principle load bank circuits. It is intended to be used as a guide along with the electrical schematic to simplify troubleshooting and the repair process. Cross reference the electrical schematic designator with the actual parts and part numbers used within the load bank to ensure accuracy as specifications are subject to change without notice. Always refer to the Load Bank Nameplate and Electrical Schematic included with this manual for specific rating information. Contact factory for direct assistance. See Load Bank Nameplate for specific model number, part number, and serial number.

SAFETY CIRCUITS	DESCRIPTION	PART NUMBER
S61 (O/T) OVERTEMP	THERMAL SWITCH	3L03-190
K99, K100, K101, K102	CONTROL RELAY, DPDT, 120 VAC COIL	W92S11A22D-120
CONTROL CIRCUITS	DESCRIPTION	PART NUMBER
F103	FUSE, CLASS CC, 600V, 5 AMP	ATDR5
	FUSE, CLASS CC, 600V, 6 AMP	ATDR6
	FUSE, CLASS CC, 600V, 7 AMP	ATDR7
	FUSE, CLASS CC, 600V, 8 AMP	ATDR8
XF103	FUSE HOLDER	GPM-SRR
S2, E-STOP	PILOT DEVICE, SWITCH, PUSHBUTTON "E-STOP"	M22-DRP-R-GB99
S1, MAIN POWER SWITCH	PILOT DEVICE, SWITCH, ILLUM, GREEN	M22-WLKV-G
S1, MAIN POWER ON	PILOT DEVICE, LIGHT, GREEN, 90-260VAC	M22-LED230-G
S1, MAIN POWER	PILOT DEVICE, SWITCH, CONTACT, NO	M22-K10
S2, E-STOP	PILOT DEVICE, CONTACT, NC	M22-K01
LOAD STEP SWITCH'S	SWITCH, TOGGLE, 250V, 16A (SPDT)	92B3802
O/T, L/D	PILOT DEVICE, INDICATOR, RED, 90-260VAC	M22-L-R-230R
LOAD STEP CONTACTORS	DESCRIPTION	PART NUMBER
	CONTACTOR, 3-POLE, 15/20 AMP, 600 VAC	XTCE015B10A
	CONTACTOR, 3-POLE, 15/20 AMP, 600 VAC	C25DND315A
	CONTACTOR, 3-POLE, 25/35 AMP, 600 VAC	C25DND325A
	CONTACTOR, 3-POLE, 30/40 AMP, 600 VAC	C25DND330A
	CONTACTOR, 3-POLE, 40/50 AMP, 600 VAC	C25DNF340A

	CONTACTOR, 3-POLE, 50/65 AMP, 600 VAC	C25DNJ350A
	CONTACTOR, 3-POLE, 60/75 AMP, 600 VAC	C25FNF360A
	CONTACTOR, 3-POLE, 75/90 AMP, 600 VAC	C25FNF375A
	CONTACTOR, 3-POLE, 90/120 AMP, 600 VAC	C25GNF390A
LOAD STEP FUSES	DESCRIPTION	PART NUMBER
	FUSE, FAST-ACTING, 15 AMP, 600 VAC	ATMR15
	FUSE, FAST-ACTING, 20 AMP, 600 VAC	ATMR20
	FUSE, FAST-ACTING, 25 AMP, 600 VAC	ATMR25
	FUSE, FAST-ACTING, 30 AMP, 600 VAC	ATMR30
	FUSE, CLASS T, 70 AMP, 600 VAC	A6T70
	FUSE, CLASS T, 80AMP, 600 VAC	A6T80
	FUSE, CLASS T, 100 AMP, 600 VAC	A6T100
	FUSE, CLASS T, 125 AMP, 600 VAC	A6T125
	FUSE, CLASS T, 150 AMP, 600 VAC	A6T150
	FUSE, CLASS T, 200 AMP, 600 VAC	A6T100
MISCELANEOUS	DESCRIPTION	PART NUMBER
XF107-F109	FUSE, FUSE BLOCK, 3 POLE	30313R
TB1	TERMINAL BLOCK, END BLOCKS	11511607
XTB1	TERMINAL BLOCK, END BLOCKS	20635116
XTB1	TERMINAL BLOCK, END BLOCKS	11836816
XTB1	GROUND BLOCK	16511417
POWER METERING	DESCRIPTION	PART NUMBER
M1	PILOT DEVICE, METER, MULTIPOWER	M850-JB69
F107-F109	FUSE, CLASS CC, 600V, 1A	ATQR1
CT1, CT2	CURRENT TRANSFORMER	SEE SCHEMATIC
CONTROL TRANSFORMER	DESCRIPTION	PART NUMBER
T1	TRANSFORMER, 250 VA, 240/480:120 VAC	E250
	TRANSFORMER, 350 VA, 240/480:120 VAC	E350
	TRANSFORMER, 500 VA, 240/480:120 VAC	E500
T1	TRANSFORMER, 250 VA, 600:120 VAC	E250JN
	TRANSFORMER, 500 VA, 600:120 VAC	E500JN
F100, F101	FUSE, CLASS CC, 600 VAC, 3 AMP	ATQR3
	FUSE, CLASS CC, 600 VAC, 4 AMP	ATQR4
	FUSE, CLASS CC, 600 VAC, 5 AMP	ATQR5
	FUSE, CLASS CC, 600 VAC, 8 AMP	ATQR8

F102	FUSE, TIME DELAY, 500 V, 5 AMP	ATQ5
	FUSE, TIME DELAY, 500 V, 6 AMP	ATQ6
	FUSE, TIME DELAY, 500 V, 7 AMP	ATQ7
	FUSE, TIME DELAY, 500 V, 8 AMP	ATQ8
XF100-F101	FUSE, FUSE BLOCK, 2 POLE	30312R
AUTO LOAD CONTROLLER	DESCRIPTION	PART NUMBER
CT100	CURRENT TRANSFORMER	SEE SCHEMATIC
S3, AUTO/MANUAL SWITCH	TOGGLE SWITCH DOUBLE THROW	7992K10
AUTO INDICATOR	PILOT DEVICE, INDICATOR, GREEN, 90-260VAC	M22-L-G-230R
K-CCR	CURRENT CONTROL RELAY	DIRT-110A
TD	TIME DELAY RELAY	822TD10H-UNI
K200	CONTROL RELAY	XTCE015B01A
K99, K199, K200, K201, K202, K203, K204	RELAY, DPDT, 120 VAC COIL	W92S11A22D-120

Appendix – Drawings and Multi-Power Meter Quick Start Guide

PROPRIETARY

The Dimensional Outline Drawings, Electrical Schematics and Interconnection Drawings included with this manual are the property of Load Banks Direct LLC, and shall remain so while in user's possession. The information is provided for the instruction, operation, maintenance and service of this equipment and not to be used for manufacturing or procurement of equipment from any source other than Load Banks Direct LLC. The technology shown here is strictly proprietary and is not to be disclosed to any 3rd party without prior consent and the express written permission of Load Banks Direct LLC.

- Multi-Power Meter Quick Start Guide
- Load Bank Dimensional Outline Drawing
- Load Bank Electrical Schematic and Interconnection Drawing

Note: If Load Bank Part Number is not listed in the Electrical and Mechanical Ratings table of this manual, it is a custom engineered to order product. The part number specific electrical schematic and top level bill of material included with this manual should always be used for specific rating information and as the reference parts list.

Always refer to the Load Bank Nameplate and Electrical Schematic included with this manual for specific rating information. Load Bank Model, Part Number, and Serial Number are listed on the Load Bank Nameplate.