

WORK ORDER SPECIFICATION

Load Technology - Work Order #: 910090.

Order Date: 09/04/91

Model: IPLB-0655.1-480DD2-0600-(9)5

Rating - Kilowatt: 655 KW

Voltage: 240 & 480V, 3PH, 3W, 50-400HZ

Power Factor: 1.0

Customer: International Generator

P.O.#: Fax of 9/4/91

Reference:

## LOAD TECHNOLOGY, INC.

### MODEL

IPLB-655.1-480DD2-5640-(9)5.0

### Rating

655 KW @ 240 or 480 V, 3 Phase, 3W, 50-400 Hz., 1.0 P.F.  
491 KW @ 208 or 416 V, 3 Phase, 3W, 50-400 Hz., 1.0 P.F.  
455 KW @ 400 V, 3 Phase, 3W, 50-400 Hz., 1.0 P.F.  
328 KW @ 240 V, 1 Phase, 2W, 50-400 Hz., 1.0 P.F.

### LOAD RESOLUTION

(9) Progressive Load Steps providing a load resolution as follows:  
5.00 KW @ 240 or 480 V, 3 Ph.  
3.75 KW @ 208 or 416 V, 3 Ph.  
3.50 KW @ 400 V, 3 Ph.  
2.50 KW @ 240 V, 1 Ph.

### LOAD STEPS

(9) Load Steps with the following nominal ratings as indicated voltages:  
240 or 480 V, 3Ph.: (1)5.00, (1)10.0, (2)20, (2)50.0, (1)100, (2)200  
208 or 416 V, 3Ph.: (1)3.75, (1) 7.5, (2)15, (2)37.5, (1) 75, (2)150  
400 V, 3Ph.: (1)3.50, (1) 7.0, (2)14, (2)35.0, (1) 70, (2)140  
240 V, 1Ph.: (1)2.50, (1) 5.0, (2)10, (2)25.0, (1) 50, (2)100

### LOAD TOLERANCE

+/- 5% of the nominal Kilowatt rating, +/- 2% phase-to-phase balance.

### \* CONFIGURATION

The Load Bank is a self contained unit equipped with metering, pilot controls, and load section in a single unit.

### ENCLOSURE

Indoor portable Nema I, with castors, captive fork lifting provisions, lifting eyes, and tie-down provisions. The enclosure is constructed completely of galvanized steel, primed and painted. It is provided with a protective door for the metering and control sections which opens to provide a writing surface. Also provided is an integral cable storage compartment in the rear of the enclosure. The storage and connection of the cables at the rear of the enclosure allows unobstructed operator access to the load bank control panel. A recessed handle is provided to assist when the unit is moved by hand.

### PHYSICAL

Dimensions: 73.5"H x 33"W x 54"D  
Weight: 1000 LBS.

### PAINT

Primer: Polyvinyl-butylal resin based etching type  
Finish: Catalyzed type polyurethane enamel

### AMBIENT

Temperature - 120° F.  
Relative Humidity - up to 100 %  
Altitude - 6000 FT. maximum

\* Indicates description that may change due to Options selected.

## LOAD TECHNOLOGY, INC.

### LOAD RESISTORS

The Loadtec RESISTAR is designed specifically for high density applications. The resistor is continuously supported to eliminate possible shorting contact with surrounding resistors. The load resistors are mounted in trays that are independently mounted so each is removable without affecting any other tray. The RESISTAR has an industry exclusive 3 year limited warranty.

### COOLING

Forced air cooled using a one piece cast aluminum propeller driven by a motor rated for the propeller's B.H.P. requirement.

### \* CONTROL POWER

Cooling Motor:

Switch selectable from the Internal (test) source or External (auxiliary) power source. The power source must be within the following ratings to be selected: 208-240/416-480 V, 60 Hz., 3 Ph. or 380-400 V, 50 Hz., 3 Ph.

Control Circuit:

120 V, 1 Ph. nominal, derived from the selected Cooling Motor power source by an integral control power transformer.

### PROTECTIVE SYSTEM

Cooling Failure:

A temperature sensor in the exhaust and a pressure differential switch are provided to sense for proper fan operation. If a failure condition is detected, the load will be disconnected.

Overvoltage:

Overvoltage circuits are provided to protect the Load Bank for inadvertent misprogramming for the applied voltage. Protection for both the Control and Load Circuits are provided since they are separately programmed.

Fused Elements:

A comprehensive fuse protection scheme is provided for individual load section & control circuit.

### LOAD CONTROL

The load is controlled by contactors that are designed for continuous and cycling operations.

### \* METERING

-Voltmeter: Analog, 600 VAC, +/-2%, 3.5"

-Voltmeter Phase Selector Switch: 4 position, L-L

-Ammeter: Analog, 1500 A, +/-2%, 3.5"

-Ammeter Phase Selector Switch: 4 position

### \* CONTROLS & INDICATORS

-Load Voltage Selector Sw.: 480VAC MAX - 240VAC MAX

-Control Voltage Selector Sw.: 416-480V, 3PH, 60HZ - 208-240V, 3PH, 60HZ

-Control Power Source/Phase Rotation Sw.: INT. (ABC)-INT. (BAC)-EXT. (ABC)-EXT. (BAC)

-Fan Start / Failure Reset Control Sw.: OFF-FAN ON-FAILURE RESET

-Cooling Failure Indicator: RED

-Overvoltage Indicator: RED

-Master Load Switch: OFF-ON

-Individual Load Step Switches: OFF-ON

\* Indicates description that may change due to Options selected.

## LOAD TECHNOLOGY, INC.

### OPTIONS

The following options change the specification sections as indicated.

#### #001 DIGITAL METERING & SYSTEM OPERATION UPGRADE CONFIGURATION

Configuration of the system is upgraded from a Basic Load Bank Unit to a Base Unit for a complete load testing system. The unit has the capability of expanding at any time to a 1950 KW @ 0.8 Power Factor testing system with the addition of auxiliary resistive and inductive units. The Base Unit metering and controls are configured for both control and total metering of the system. The interface receptacles are provided to connect the Auxiliary units for control and metering summation. This system is a discrete summation system and does not require the conventional Totalizing Current Transformer Tray eliminating the power connection difficulties.

#### METERING

Voltmeter & Ammeter are upgraded to Digital which function as Unit Metering as well as System Metering when Auxiliary/Slave Units are used. Circuitry is also provided to allow the Base unit to function as a Auxiliary/Slave unit allowing metering totalization at the designated Base Unit

-Voltmeter: 500 V, +/-0.2% +/-2 Digits, 1 V Resolution

-Ammeter: 3000 A, +/-0.2% +/-2 Digits, 1 A Resolution

-Metering Mode Selector Switch: TOTAL-UNIT-AUX

#### CONTROLS & INDICATORS

Pilot Controls are added for load control of Auxiliary/Slave Unit(s).

#### #002A DIGITAL FREQUENCY METER

35.0-500.0 Hz, +/-0.2 Hz., 0.1 Hz. resolution (requires option #001)

#### #002B ANALOG FREQUENCY METER

45-65 Hz., Dial Type, 3% of span, 3.5" (not used with option #001 or #002C)

#### #002C ANALOG FREQUENCY METER

360-440 Hz., Dial Type, 3% of span, 3.5" (not used with option #001 or #002B)

#### #003A DIGITAL KILOWATT METER

2000 KW, +/-0.2% +/-2 Digits, 1 KW resolution (requires option #001)

Functions as Unit & System Metering when Auxiliary/Slave units are used.

#### #003A ANALOG KILOWATT METER

800KW, +/-2%, 3.5"(not used with option #001), Functions as Unit Metering only

#### #004 PROTECTIVE COVER

Form fit cover made of synthetic fabric that is water repellent but "breathes" to allow trapped moisture to escape reducing corrosion because of moisture retention common to vinyl materials.

#### #005 DIGITAL KILOVAR METER

2000 KVAR, +/-0.2% +/-2 Digits, 1 KVAR Resolution (requires option #001)

Functions as System Metering when Auxiliary Inductive unit(s) are used.

#### #006 POWER FACTOR METER

Analog, .5 LAG - 1.0 - .5 LEAD, +/-2%, 3.5" (requires option #001)

Functions as System Metering when Auxiliary Inductive units are used.

## LOAD TECHNOLOGY, INC.

### LOAD VOLTAGE Switch:

This switch programs the load for the applied test source voltage. It is a two (2) position switch with legend: 480 VAC MAX - 240 VAC MAX. Placing the switch in the respective position selects the proper load resistor scheme and programs the over voltage protective circuit.

Test sources can be applied to the Load Bank that are of lower voltage rating than the selected voltage range. The main consideration in programming is not to exceed the selected voltage maximum.

There is a lower voltage type application that is useful when testing small kilowatt, low voltage systems when smaller kilowatt step ratings are desired. In a typical example of this application, a 240 VAC test source is applied with the Load Voltage switch in the 480 VAC MAX position. The load steps will have a rating that are 25% of the nominal nameplate rating. For other reduced voltage load step ratings see the Reduced Voltage portion of the Calculations section.

### CONTROL VOLTAGE Switch:

This switch programs the control circuitry for the selected control power source. It is a two (2) position switch with legend: 416-480 VAC, 3 Phase, 60Hz./ 380-400 VAC, 3 Phase, 50 Hz. - 208-240 VAC, 3 Phase, 60 Hz. The switch selects the proper programming for the cooling motor, control power transformers, and the control over voltage protective circuit.

### CONTROL POWER, SOURCE/PHASE ROTATION Switch:

This switch selects the source and phase rotation for the control power. The switch is a (4) position rotary type with legend: INT.ABC - INT.BAC - EXT.ABC - EXT.BAC. In either of the INT. (internal) positions, the control power is derived from the source being tested. In either of the EXT. (external) positions, the control power is derived from the power source connected to the external power connection terminal block.

The ABC and BAC positions of the two source positions allows the selection of the fan rotation so the proper air flow direction can be achieved without concern for the power source's phase rotation. If the air flow is in the wrong direction, the fan must be turned off and the fan allowed to stop before switching to the opposite phase rotation. After selecting the opposite rotation position of the selected power source, the fan can be re-energized.

**CAUTION: FAN MUST STOP BEFORE REVERSING**

### FAN START / FAILURE RESET Switch:

This switch performs a dual function, it controls the cooling fan and resets the cooling failure circuitry. The switch is a (3) position toggle switch with legend: OFF - FAN ON - FAILURE RESET(momentary). When the switch is in the OFF position, all Load Bank circuits are disconnected except for the over voltage sensing circuitry. If no over voltage condition exists, placing the switch in the FAN ON position will start the cooling fan and enable the control circuitry. After the fan has reached full speed and an adequate air flow is achieved, the cooling failure can be reset by placing the switch in the FAILURE RESET (momentary) position. The switch can be released when the cooling failure indicator turns off which indicates the cooling failure circuit has been reset. When the cooling failure is reset, the load steps are enabled.

## LOAD TECHNOLOGY, INC.

### MASTER LOAD Switch:

This switch controls the energization of the individual load steps. The switch can be used for simultaneous energization of selected load steps or can be placed in the ON position so each load step will be energized as it is turned ON. This switch also controls the energization of the Auxiliary Unit switches.

### LOAD STEP Switches:

These switches control the individual load steps. Placing the Load Step switch in the ON position (with the Master Load switch in the ON position and with a Cooling Failure not indicated) will energize its respective load.

### AUXILIARY UNIT Switches: \*\* (Option #001)

These switches control any connected Auxiliary/Slave unit(s) as if it were an individual load step. The units will energize any selected load from the Auxiliary/Slave unit(s).

### COOLING FAILURE:

The cooling failure circuit is a permissive type which requires relay energization for normal operation, the relay drops out on a failure condition. This type of circuit insures proper operation of the control devices, not relying on operation on a fault condition.

A cooling failure condition will illuminate the indicator light and dropout all energized loads. The failure will continue to be indicated until the fault condition is corrected and reset.

The air flow is monitored by a differential pressure switch. A cooling failure is indicated if no air flow is indicated or the flow is in the wrong direction.

An excessive exhaust temperature is sensed by a temperature switch mounted in the load resistor chamber exhaust. When the exhaust temperature approaches a damaging level, the switch will activate the cooling failure circuit.

### OVER VOLTAGE:

The over voltage circuit monitors both the Load and Control circuits for an over voltage condition caused by misprogramming of either of the Load Voltage or Control Voltage switches.

This mechanical indicator trips when there is an over voltage in either circuit. An over voltage tripped condition will disconnect all circuits. The normal position of the monitor is in the ON position.

\*\* Indicates items, features, & functions that are optional.

## LOAD TECHNOLOGY, INC.

### METERS \*\*

#### **VOLTMETER**

Indicates the applied test voltage for the phase reference selected by the Voltmeter switch.

#### **AMMETER**

Indicates the load applied to the the test source in amperes for the phase reference selected by the Ammeter switch and the function as selected by the Metering Mode switch.

#### **FREQUENCY METER** \*\*

Indicates the test source's alternating current frequency

#### **KILOWATT METER** \*\*

Indicates the load applied to the test source in kilowatts (true power).

#### **KILOVAR METER** \*\*

Indicates the load applied to the test source in kilovars (reactive power). This meter functions only in conjunction with Auxiliary(Slave) Inductive units.

#### **POWER FACTOR METER** \*\*

Indicates the phase angle relationship of the current to the voltage. The phase and is displayed as a function of the Cosine of the angle. This meter functions only in conjunction with Auxiliary(Slave) Inductive units.

### VOLTMETER Switch \*\*

The Voltmeter switch is used to connect the voltmeter to the desired phase references. The switch is a four (4) position rotary legend: OFF, L1-L2, L2-L3, L3-L1.

### AMMETER Switch \*\*

The Ammeter switch is used to connect the ammeter to the desired phase reference. The switch is a four (4) position rotary legend: OFF, L1, L2, L3.

### METERING MODE Switch: \*\* (Option #001)

This switch controls the function of the metering system. This switch is a three (3) position rotary type with legend: TOTAL - UNIT - AUX. (SLAVE).

If the unit is to function as a Base unit and provide total system monitoring, place the Metering Mode switch in the TOTAL position. With the switch in the TOTAL position, the meters function as system metering and will sum and totalize the values from all connected Auxiliary(Slave) units.

If the unit is to function as a Basic unit and operate individually, place the Metering Mode switch in the UNIT position. With the switch in the UNIT position, the meters function as unit metering only and monitor only its values.

If the unit is to function as an Auxiliary(Slave) unit, place the Metering Mode switch in the AUX.(SLAVE) position. With the switch in the AUX.(SLAVE) position, metering in the current loop circuit is disconnected and the current loop is enabled for connection to the unit functioning as the Base for system summation and totalizing. The current loop metering is also turned off in this position.

\*\* Indicates items, features, & functions that are optional.

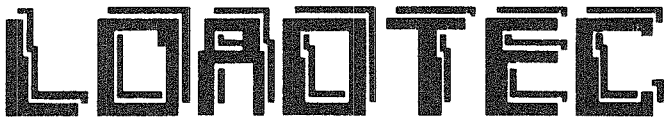

## LOAD TECHNOLOGY, INC.

### NORMAL OPERATION

- 1) Place the Load Bank in the desired operating location. Clear surface area of any loose debris that could be picked up by the air intakes. Assure there are no intake or exhaust obstructions and adequate ventilation to maintain an acceptable ambient conditions.
- 2) Connect the Load Bank to the Test Source as shown on the connection diagram.

\*\*\*\*\* W A R N I N G \*\*\*\*\*  
FOR OPERATOR SAFETY The Load Bank MUST BE ELECTRICALLY GROUNDED  
in accordance with the National Electrical Code & any local codes.  
\*\*\*\*\*

- 3) If required, connect an external power source (rating as indicated on the connection diagram) to the terminal block or if the applied Load Voltage is outside the nameplate specified Control Voltage operating range.
- 4) Connect the auxiliary unit(s) umbilical cord(s) (if used).
- 5) Program the Load Voltage Switch for the voltage of the Test Source.
- 6) Program the Control Voltage Switch for the voltage of the control power source.
- 7) Program the Control Power Source/Phase Rotation Switch for the source of the control power and phase rotation (Internal test or External auxiliary).
- 8) Program the Metering Mode Switch to the proper position for the required functional operation of the Load Bank. (if supplied, option #001)
- 9) Check that the Over Voltage trip indicator is in the ON position.
- 10) Turn off the Fan Start/Failure Reset Switch, all Load Step Switches, Master Load Switch, and Auxiliary Unit Control Switch.
- 11) Energize the test source and the control power (if used).
- 12) Switch the Fan Start/Failure Reset Switch to the FAN ON position. The fan should start.
- 13) Switch the Fan Start/Failure Reset Switch to the FAILURE RESET momentary position. The cooling failure should reset.
- 14) If the cooling failure does not reset, check for proper air flow direction. The air flow should exhaust the top of the unit. If the air flow is reversed, turn off the cooling fan by placing the Fan Start/Failure Reset Switch to the OFF position. Place the Control Power Source/Phase Rotation Selector Switch in the opposite rotation for the selected control power source. After the fan has come to a complete stop, repeat steps #11 & #12  
CAUTION - Fan must stop before reversing.
- 15) After the Cooling Failure is reset, the required load can be energized.

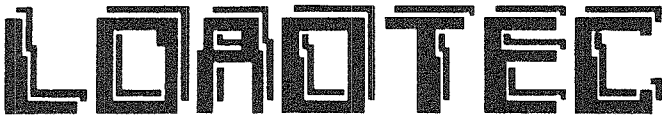

## LOAD TECHNOLOGY, INC.

### NORMAL SHUTDOWN

- 1) Turn of any energized load steps.
- 2) Switch the Fan Start / Failure Reset Switch to the OFF position.
- 3) Turn off the test source and the external control power source (if used).
- 4) Disconnect the Load Bank from the test source, the external control power source, and the auxiliary unit(s) umbilical cord(s) (if used).

### FAILURE SHUTDOWN

- 1) The Load Bank is supplied with a protective shutdown system.
- 2) If the protective system senses a fault condition, the load will be disconnected.
- 3) The source and cause of the fault must be identified and corrected before restarting the Load Bank.

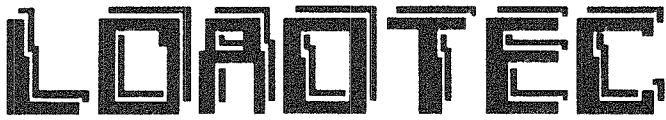

## LOAD TECHNOLOGY, INC.

The Load Bank has been designed to require minimum maintenance. All components have been selected for their high quality and long life. There are two basic maintenance intervals, each operation and annually.

### EACH OPERATION:

A general visual check should be made before each use. Check for any physical damage that could cause an electrical or mechanical failure, damaged control components, and any air intake or exhaust restrictions.

Due to high volume of cooling air required, the air intake screen is susceptible to obstruction by foreign objects. The intake screens must be periodically checked for obstructions. An easy way to clear the area of loose debris is to reverse the direction of the propeller fan when first located in the operating area. This will blow away any loose debris.

### Annually:

All electrical connections should be checked for tightness. Due to the repeated cycling type operations, the electrical connections are susceptible to loosening because of the expansion and contractions caused by repeated heating and cooling. The vibrations caused by the propeller fan and transportation also contributes to the loosening of connections. If the Load Bank is routinely transported over the road, a 6 month tightening schedule should be followed.

The electrical connections should be precisely torqued when tightness is checked. Over tightening can cause terminal insulators to fail. The load resistor terminals should be torqued to 18 inch pounds.

The fan motor's bearings should be lubricated annually.

## LOAD TECHNOLOGY, INC.

### 3 Phase Kilowatts:

KW = Kilowatts  
V = Volts (L-L)  
A = Amps (average)  
PF = Power Factor (resistive = 1.0)

$$KW = \frac{V \times A \times PF \times 1.732}{1000}$$

### Single Phase Kilowatts:

$$KW = \frac{V \times A \times PF}{1000}$$

### Reduced Voltage:

Used to determine the new load step rating at other than a known voltage rating.

$$\text{New KW} = \left| \frac{\text{New Voltage}}{\text{Referenced Voltage}} \right|^2 \times \text{Referenced KW Rating}$$

REFERENCED refers to a specified or known KW rating at a specific voltage.

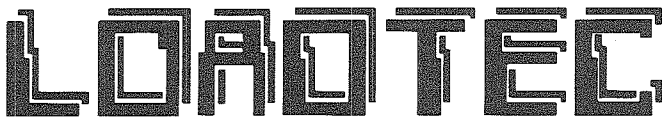
**LOAD TECHNOLOGY, INC.**

Approved By: \_\_\_\_\_

WO#: 910090

ITEM	QTY	LIT#	DESCRIPTION
01	1	050207	LOAD BANK ENCL: PORTABLE, NEMA 1, 73.0"H x 33.0"W x 54.0"D MFG:LOADTEC PN:IPLB
01A	2	030077	CASTOR: SWIVEL, 6" x 2" WHEEL, 900 LBS CAPACITY MFG:AMERICAN PACIFIC PN:80-PH-6RB
01B	2	030078	CASTOR: FIXED, 6" x 2" WHEEL, 900 LBS CAPACITY MFG:AMERICAN PACIFIC PN:81-PH-6RB
01C	4	080016	EYE BOLT: 5/8"-11 THREAD MFG:SOUTHCO PN:3014T52
01D	5	080014	LIFT & TURN FLUSH LATCH: W/ STD PAWL MFG:SOUTHCO PN:62-10-401-10
01E	1	080030	DOOR BRACES: LEFT & RIGHT HAND PAIR MFG:MCMMASTER-CARR PN:1571A11
01F	1	140122	NAMEPLATE: METERING PANEL, (4) METER STD, W/MMS MFG:LOADTEC PN:140122
01G	1	140114	NAMEPLATE: CONTROL PANEL, 655KW BASE UNIT STD MFG:LOADTEC PN:140114
01H	1	030101	PROTECTIVE COVER FOR LOAD BANK MODEL "IPLB" MFG:LOADTEC PN:030101
04A	3	180112	LOAD RESISTOR: 1667W @ 139V MFG:LOADTEC PN:LR1667/139/051/11.1-S1.5
04B	3	180132	LOAD RESISTOR: 1250W @ 208V MFG:LOADTEC PN:LR1250/208/036/33.0-S1.5
05A	3	180125	LOAD RESISTOR: 3333W @ 139V MFG:LOADTEC PN:LR3333/139/064/5.52-S1.5
05B	3	180133	LOAD RESISTOR: 2500W @ 208V MFG:LOADTEC PN:LR2500/208/045/16.5-S1.5
06	12	180110	LOAD RESISTOR: 3333W @ 240V MFG:LOADTEC PN:LR3333/240/045/16.9-S1.5
07	144	180103	LOAD RESISTOR: 4167W @ 240V MFG:LOADTEC PN:LR4167/240/051/13.0-S1.5
08	2	030079	CONTACTOR: 25A @ 600 VAC, 3P, 120VAC COIL MFG:SPRECHER+SCHUH PN:CA3-9-10-120-NO
08A	2	030083	CONTACTOR TIMING MODULE: DPDT, "OFF" DELAY, .3-30 SECONDS MFG:SPRECHER+SCHUH PN:CZA3-30S
08B	2	030084	CONTACTOR AUX CONTACT: SIDE MOUNT, (2)N.O. MFG:GENERAL ELECTRIC PN:CR4XA208
10	8	030079	CONTACTOR: 25A @ 600 VAC, 3P, 120VAC COIL MFG:SPRECHER+SCHUH PN:CA3-9-10-120-NO
11	24	030081	CONTACTOR: 63A @ 600 VAC, 3P, 120VAC COIL MFG:SPRECHER+SCHUH PN:CA3-37-120-NO
12	83	060007	FUSE: 70 AMP, CLASS "T" MFG:BUSSMANN PN:JJN70
13	3	060010	FUSE BLOCK: 30 AMP, 3 POLE, CLASS "M" MFG:CONNECTRON PN:M633-66

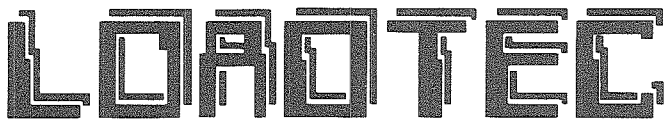
**LOAD TECHNOLOGY, INC.**

Approved By: \_\_\_\_\_

WO#: 910090

ITEM	QTY	LIT#	DESCRIPTION	
14	7	060001	FUSE: 5 AMP, 600 VAC MFG:BUSSMANN	PN:KTK5
15	2	060002	FUSE: 10 AMP, 600 VAC MFG:BUSSMANN	PN:KTK10
16	1	030088	CIRCUIT BREAKER: 20A, 3P, 480V, MINIATURE MFG:WEBER	PN:AS168-SG20
17	1	030015	CIRCUIT BREAKER MOUNTING RAIL MFG:CMC	PN:815372
18	1	030012	CIRCUIT BREAKER: 2 POLE, RELAY TRIP TYPE, 50 MA TRIP COIL MFG:AIRPAX	PN:APG-66-4-6-1-051-21
19	2	180002	RELAY: 3PDT, 10A @ 28VDC/120VAC, 120VAC COIL MFG:IDEC	PN:RR3B-U-AC120V
19A	2	180005	RELAY BASE: 11 BLADE, SURFACE MOUNTED MFG:IDEC	PN:SR3B-02
20	1	190015	PRESSURE DIFFERENTIAL SW: .15-.5" W.C., SPST MFG:DWYER	PN:1910-0
20A	1	190016	STATIC PRESSURE SENSOR MFG:DWYER	PN:A-305
20B	2	190017	FITTING: 1/8" NPT CLOSE COUPLED STREET ELL MFG:DWYER	PN:A329
20C	1	190018	FITTING: 1/8" NPT BRASS COUPLING MFG:DWYER	PN:A337
20D	2	190019	FITTING: 1/8" NPT TO 1/4" ID TUBING ADAPTER MFG:DWYER	PN:A339
20E	6	190020	PLASTIC TUBING: 1/4" ID MFG:DWYER	PN:A220
21	1	190023	TEMPERATURE SW: SPST, N.C., SET AT 550 F., FLANGE MOUNT MFG:VULCAN	PN:1D1B2-A(550F)
22	2	190066	TOGGLE SWITCH: 3PDT, 2 POS, 10A @ 250 VAC, 1/4" TAB TERM. MFG:CARLING	PN:HL251-73
23	12	190035	TOGGLE SWITCH: SPST, 2 POS, 10A @ 250 VAC, 1/4" TAB TERM. MFG:CARLING	PN:2FA53-73
24	1	190004	TOGGLE SWITCH: DP3T, OFF/CRK#1 ON/CRK#1&2 ON(MOM), 1/4" TAB MFG:CARLING	PN:6GG5B-73
25	1	190026	ROTARY SWITCH: 3P, 4 POS, W/O OFF, W/O ESC. MFG:SALZER	PN:S213-US1A992-10
27	1	120007	LIGHT: BASE, ROUND, OILTIGHT, MINIATURE BAYONET BASE MFG:IDEC	PN:APW-199
27A	1	120008	LENSE: RED, ROUND, FLUSH MFG:IDEC	PN:APW1LN-R
27B	1	020001	BULB: 130V, MINIATURE BAYONET BASE MFG:SCHLEGEL	PN:FZ9R-130V
29	2	180010	RESISTOR: 2200 OHM, FIXED, 12 WATT MFG:OHMITE	PN:3810

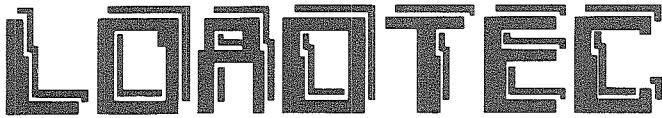
**LOAD TECHNOLOGY, INC.**

Approved By: \_\_\_\_\_

WO#: 910090

ITEM	QTY	LIT#	DESCRIPTION
30	2	200057	TRANSFORMER: 100 VA, 480/240:240/120 MFG:MICRON PN:V100FU1519JJ
31	1	200020	TRANSFORMER: 500 VA, 480/240:120 MFG:ACME PN:TA-1-81215
32	1	130103	VOLTIMETER: DIGITAL, 600V SCALE, 150 V INPUT, 120 VAC PWR MFG:ELECTRO PN:MV-U-150/600
33	1	130106	AMMETER: DIGITAL, DUAL RANGE, 1500/3000 AMP, 5A INPUT, AVG RESP MFG:ELECTRO PN:MA-U-DR
34A	2	200058	CURRENT TRANSFORMER: 1500/5 RATIO MFG:CROMPTON PN:797-941U-TCLS
34B	2	200037	CURRENT TRANSFORMER: 3000/5 RATIO MFG:CROMPTON PN:797-941U-UALS
34C	2	200038	CURRENT TRANSFORMER BRACKET: FOR 797 SERIES MFG:CROMPTON PN:0221B00187
35	1	190006	VOLTIMETER SWITCH: L-L, 4 POS, W/O ESCUTCHEON MFG:SALZER PN:S213-61312-10
36	1	190008	AMMETER SWITCH: 3PH, 4 POS, 2 CT'S, W/O ESCUTCHEON MFG:SALZER PN:S213-61331-10
37	1	130083	FREQUENCY METER: DIGITAL, 999.9 HZ, 5-300V INPUT, 120 VAC PWR MFG:ELECTRO PN:MF-U-2
38	1	130107	KW METER: DIGITAL, 1000/2000 KW, 120V/5A, 1500/3000:5 CT, 2ELEM MFG:ELECTRO PN:MW-U-Y-DR
40	1	130029	MOTOR: 3 HP, 208-230/460 VAC, 3 PH, 182T FRAME, ODP MFG:LEROY-SOMER PN:51HT48
40A	1	060015	FAN BLADE: 24" DIA, 1.13" BORE, 3 HP MFG:HARTZELL PN:24WK3(1921)
40B	1	060013	FAN VENTURI: 24" DIAMETER MFG:DAYTON PN:3C305
41	1	030018	CIRCULAR CONNECTOR: RECEPTACLE, 14 CONTACT, SOCKET CONTACTS MFG:AMP PN:206043-1
42	2	030017	CIRCULAR CONNECTOR: RECEPTACLE, 16 CONTACT, PIN CONTACTS MFG:AMP PN:206036-1
45	10	030022	CIRCULAR CONNECTOR: PIN CONTACTS MFG:AMP PN:66701-1
46	7	030023	CIRCULAR CONNECTOR: SOCKET CONTACTS MFG:AMP PN:66705-1
49	117	200014	TERMINAL BLOCK SECTION: 30 AMP, 600 V, TUBULAR CLAMP TYPE MFG:BUCHANAN PN:715
49A	3	200015	TERMINAL BLOCK END BARRIER: 30 AMP BLOCK MFG:BUCHANAN PN:730
50	15	090013	INSULATOR: 2.75" H, 3/8"-16 x .375" DEEP THREAD INSERT MFG:MAR-BAL PN:5275-A5
51	6	120006	MECHANICAL LUG: (2) 600MCM-#2AWG MFG:ILSCO PN:AU-600

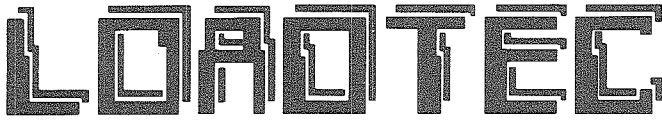

**LOAD TECHNOLOGY, INC.**

Approved By: \_\_\_\_\_

WO#: 910090

<u>ITEM</u>	<u>QTY</u>	<u>LIT#</u>	<u>DESCRIPTION</u>
52	1	120005	MECHANICAL LUG: (1) 600MCM-#4AWG or (2) 250MCM-1/0AWG MFG:ILSCO PN:TA-500S
58	1	190071	METERING MODE SWITCH: 3 POS., 15 CONT., 15A, 600V MFG:SAZER PN:S213-US1A-1811-00
59	1	200062	METERING TRANSFORMER: 480:120, 3PH, OPEN DELTA MFG:INSTRUMENT TRANSFORMER PN:469-480

END OF REPORT: 4 PAGES

## LOAD TECHNOLOGY, INC.

AFS ..Air Flow Sw.	HSS ..Horn Silence Switch	PB ..Pushbutton Sw.
ALR ..Automatic Load Relay	HVC ..High Voltage Contactor	PC ..Pilot Contactor
ALS ..Auxiliary Unit Control Sw.	HZFR..Freq.(Hertz) Failure Relay	PFM ..Power Factor Meter
AM ..Ammeter	HZFT..Freq.(Hertz) Failure Timer	PFMS..Power Factor Meter Sw.
AMS ..Ammeter Phase Sw.	HZR ..Frequency (Hertz) Relay	PFT ..Power Factor Transducer
ARS ..Ammeter Range Sw.	KVM ..Kilovar Meter	PLC ..Programmable Logic Cntrlr
C ..Load Contactor	KVT ..Kilovar Transducer	PLG ..Plug
CEL ..Control Enabled Light	KWM ..Kilowatt Meter	PT ..Potential Transformer
CF ..Control Circuit Fuse	KWMS..Kilowatt Meter Sw.	R ..Resistor
CFL ..Cooling Failure Light	KWT ..Kilowatt Transducer	RB ..Rectifier Bridge
CFR ..Cooling Failure Relay	L ..Line	RCP ..Recepticle
CLS ..Control Location Switch	LBOL..Load Bank Operating Light	RDL ..Remote Disconnect Light
CMS ..Control Mode Switch	LDL ..Load Dump Light	RHS ..Metering Read/Hold Sw.
CPB ..Control Power Circuit Brkr	LI ..Load Inductor	RLY ..Relay
CPC ..Control Power Contactor	LR ..Load Resistor	RPR ..Reverse Power Relay
CPL ..Control Power Light	LRS ..Local/Remote Control Sw.	RSR ..Reset Relay
CPR ..Control Power Relay	LS ..Load Step Sw.	RTD ..Resistance Temp. Device
CPS ..Control Power Switch	LST ..Load Sequence Timer	RTM ..Running Time Meter
CPT ..Control Power Transformer	LVC ..Low Voltage Contactor	SEL ..Section Enabled Light
CPU ..PLC Processor Unit	LVR ..Low Voltage Relay	SH ..Space Heater
CR ..Current Relay	LVS ..Load Voltage Switch	SHC ..Space Heater Contactor
CSR ..Cntrl Source/Rotation Sw.	MC ..Motor Contactor	SHD ..Space Heater Disconnect
CT ..Current Transformer	MCB ..Main Circuit Breaker	SL ..Load Step Light
CVS ..Control Voltage Sw.	MCH ..Motor Contactor-Hi Voltage	SNT ..Shunt
CXR ..Contactor Pilot Relay	MCHT..Motor Contactor-HV Timer	SSR ..Solid State Relay
CXT ..Current Transducer	MCL ..Motor Contactor-Low Voltage	ST ..Shunt Trip
C_T ..Contactor Timer	MCLT..Motor Contactor-LV Timer	TB ..Terminal Block
D ..Diode	MDS ..Main Disconnct Sw.	TCS ..Test Control Switch
DPB ..Disable Pushbutton	MLL ..Master Load Light	TDEC..Time Delay Engine Cooldown
EFL ..Exercise Failure Light	MLR ..Master Load Relay	TDF ..Time Delay Failure
EFR ..Exercise Failure Relay	MLS ..Master Load Sw.	TDI ..Time Delay Initial
EFT ..Exercise Failure Timer	MMS ..Metering Mode Switch	TDL..T.D. Load Bank Cooldown
EPB ..Enable Pushbutton	MOD ..PLC I/O Module	TDS ..Time Delay Sequence
EXDC..Exercise Day Counter	MOL ..Manual Operation Light	THS ..Thermostat Switch
EXL ..Exercise Light	MOR ..Manual Override Relay	TS ..Temperature Sw.
EXR ..Exercise Relay	MOT ..Fan Motor	TSL ..Test Source Light
EXT ..Exercise Timer	MOV ..Metal Oxide Varistor	TSP ..Test Start Pushbutton
EXTR..Exercise Timer Pilot Relay	MPT ..Metering Potential Xformer	TSS ..Test Source Selector
F ..Load Fuse	MR ..Meter Relay	TTL ..Transformer OverTemp Light
FFS ..Fan Start/Failure Reset Sw.	NEU ..Neutral	UFS ..Under Frequency Sensor
FM ..Frequency Meter	NOL ..Normal Operation Light	UVS ..Under Voltage Sensor
FR ..Failure Relay	NOR ..Normal Operation Relay	VAR ..Voltage Adjust Rheostat
FRL ..Fan On Light	NP ..Nameplate	VHL ..Voltage/Hertz Failure Light
FSR ..Frequency Sensing Relay	NPR ..Normal Power Relay	VLS ..Vernier Load Sw.
FT ..Frequency Transducer	NPT ..Normal Power Timer	VM ..Voltmeter
GFL ..Ground Fault Light	OPF ..Load OFF pushbutton	VMS ..Voltmeter Phase Sw.
GFR ..Ground Fault Relay	OLR ..Overload Relay	VPI ..Vernier Position Indicator
GFS ..Ground Fault Sensor	ONP ..Load ON Pushbutton	VRC ..Variable Auto Transformer
GND ..Ground	OVL ..Overvoltage Light	VT ..Voltage Transducer
GSL ..Generator Starting Light	OVR ..Overvoltage Relay	
HRN ..Horn	OVS ..Overvoltage Sensor	



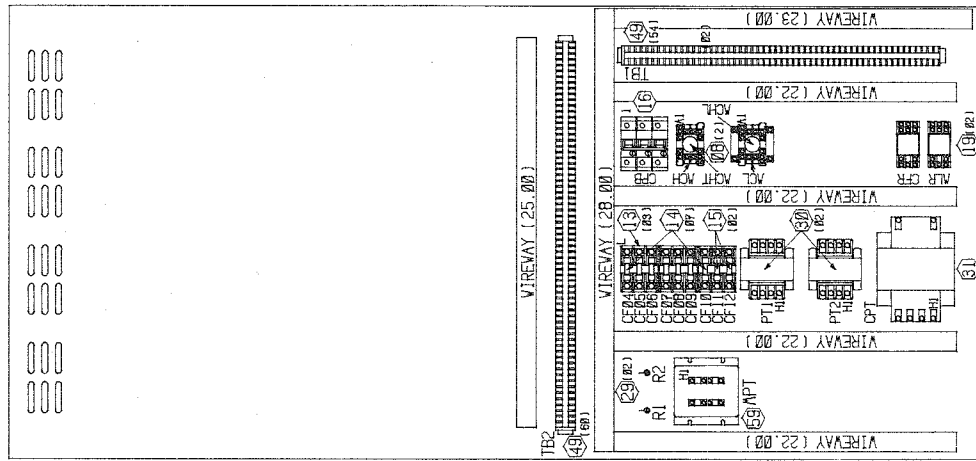

FRONT COMPONENT PANEL

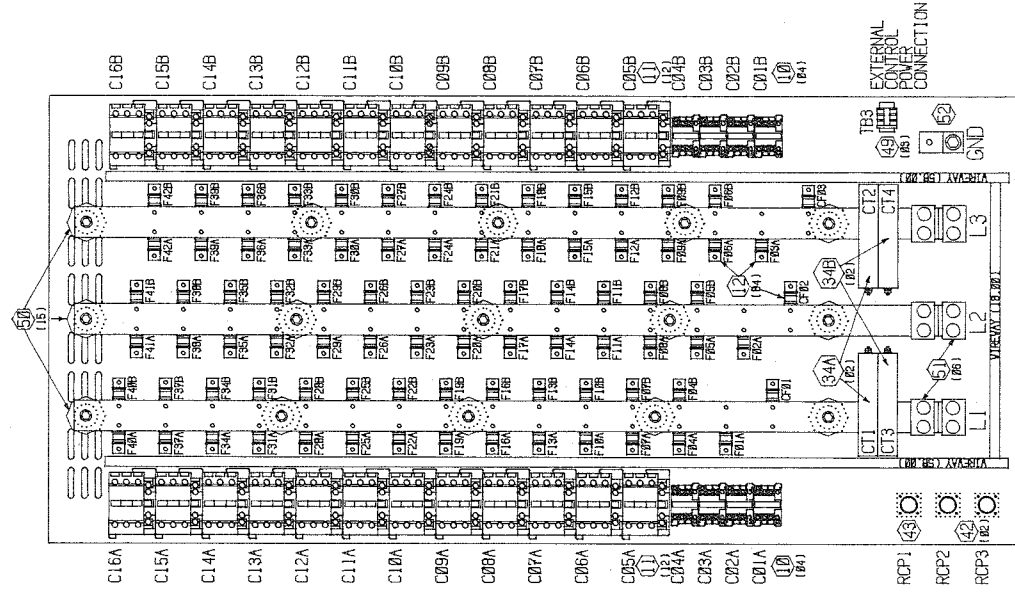

REAR COMPONENT PANEL

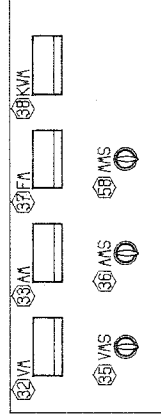

METERING PANEL

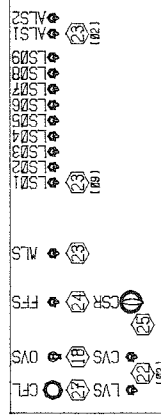

CONTROL PANEL

NOTES

- (1) INDICATES BILL OF MATERIAL ITEM NUMBER
- (10) INDICATES QUANTITY FOR BILL OF MATERIAL ITEM

**LOADTEC** LOAD TECHNOLOGY, INC.  
 SCALE: 0.250 APPROVED  
 DATE: 10/24/91  
 PORTABLE LOAD BANK  
 COMPONENT ARRANGEMENT DETAIL  
 V.O. # 910090  
 DRAWING No. 910090-02

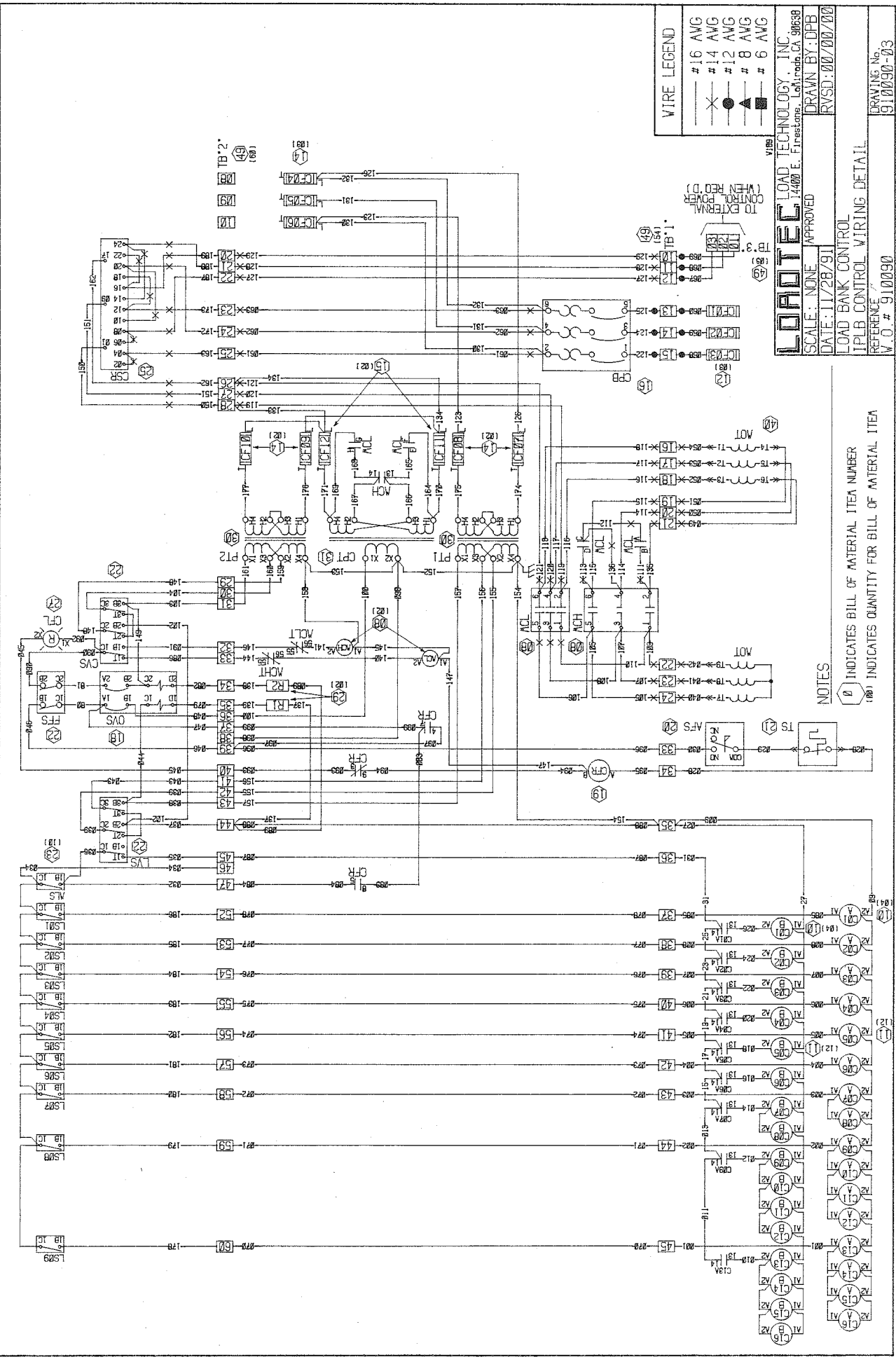

**WIRE LEGEND**

—	# 16 AVG
—	# 14 AVG
—	# 12 AVG
—	# 8 AVG
—	# 6 AVG

**LOADTEC** LOAD TECHNOLOGY, INC.  
 14400 E. Firestone, Littleton, CO 80120  
 SCALE: NONE APPROVED  
 DRAWN BY: DPB  
 RVSJ: 00/00/00  
 DATE: 11/28/91  
 LOAD BANK CONTROL  
 IPLB CONTROL WIRING DETAIL  
 REFERENCE:  
 V.O.# 910090-03  
 DRAWING No. 910090-03

**NOTES**

① INDICATES BILL OF MATERIAL ITEM NUMBER  
 ② INDICATES QUANTITY FOR BILL OF MATERIAL ITEM

**WIRE LEGEND**

- # 16 AWG
- X- # 14 AWG
- # 12 AWG
- ▲ # 8 AWG
- # 6 AWG

**NOTES**

- (D) INDICATES BILL OF MATERIAL SHEET NUMBER
- (QTY) INDICATES QUANTITY FOR BILL OF MATERIAL ITEM

**LOAPOTEC LOAD TECHNOLOGY, INC.**  
 14400 E. Firmin Drive, Los Angeles, CA 90038  
 DRAWN BY: DPB  
 DATE: 10/28/91  
 SCALE: NONE APPROVED  
 RVSD: 00/00/00

PORTABLE LOAD BANK  
 METERING WIRING DIAGRAM  
 REFERENCE  
 W.O.# 910090-04  
 DRAWING NO. 910090-04

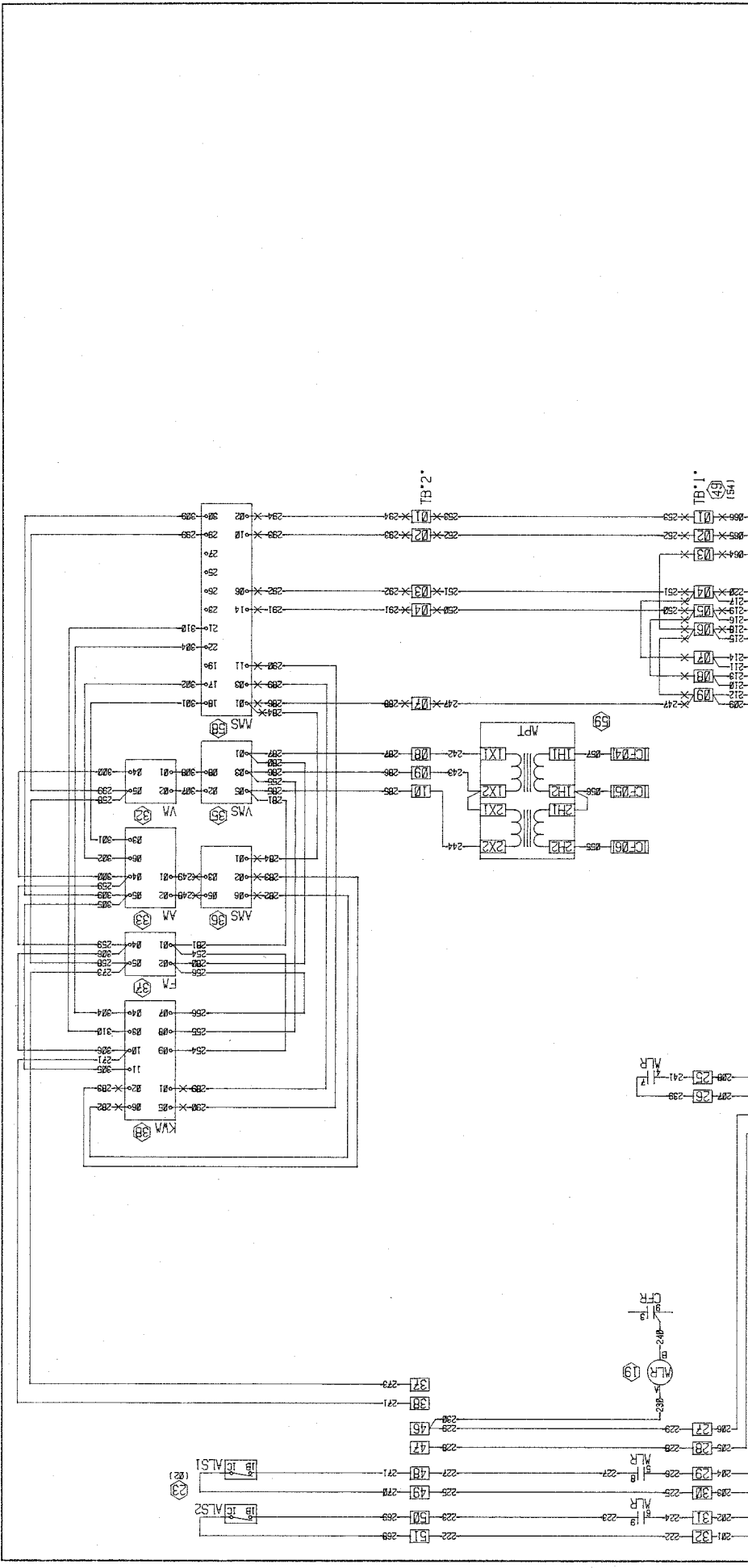

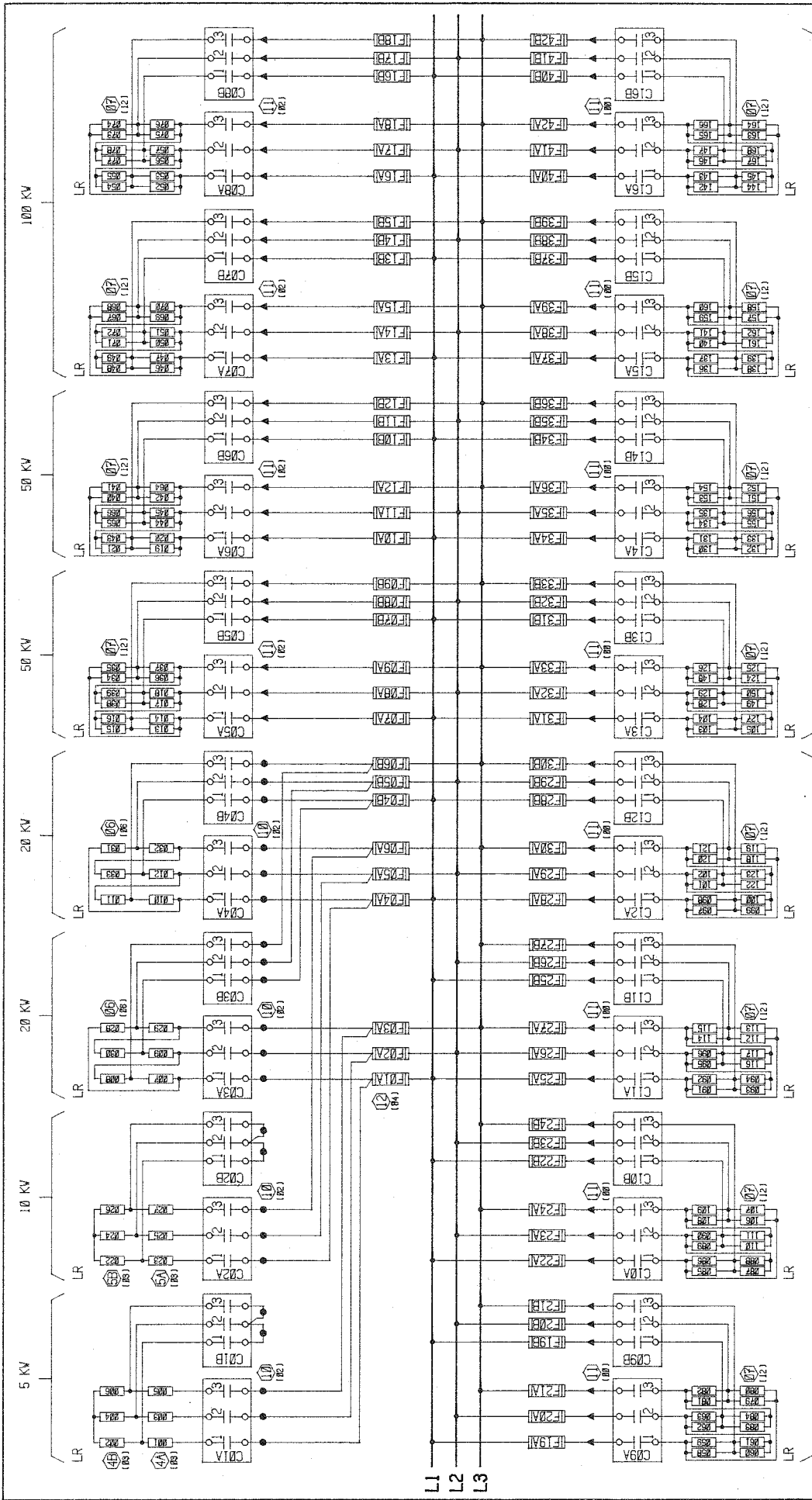

WIRE LEGEND

SCALE: NONE APPROVED

DATE: 11/28/91

RESISTIVE LOAD BANK

POWER WIRING DETAIL

REFERENCE

V.O.# 910090

DRAWING No. 910090-05

LOADTEC LOAD TECHNOLOGY, INC.  
14407 E. Fresno, CA 95638

DRAWN BY: DPB

RVSD: 00/00/00

NOTES

Ø INDICATES BILL OF MATERIAL ITEM NUMBER

(100) INDICATES QUANTITY FOR BILL OF MATERIAL ITEM

1000 KV

500 KV

200 KV

200 KV

100 KV

50 KV

20 KV

10 KV

5 KV

L1

L2

L3

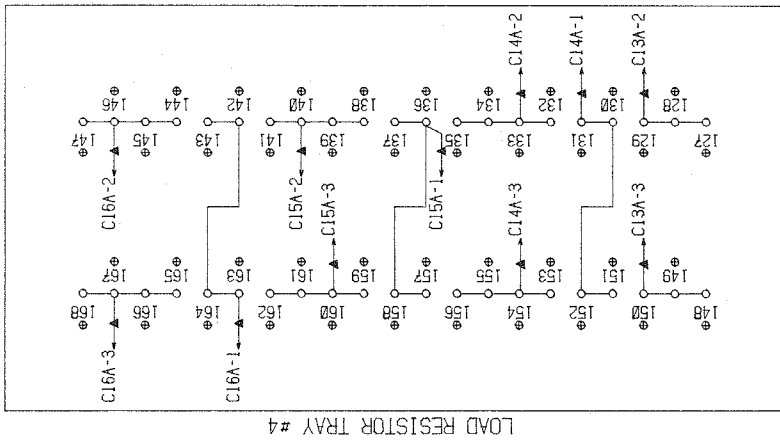

LOAD RESISTOR TRAY #4

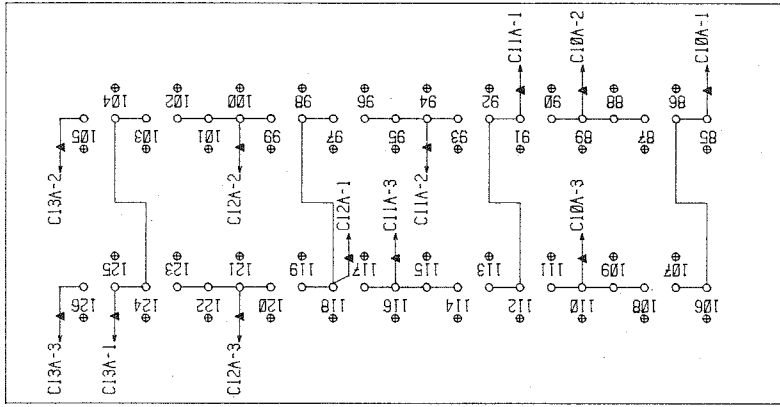

LOAD RESISTOR TRAY #3

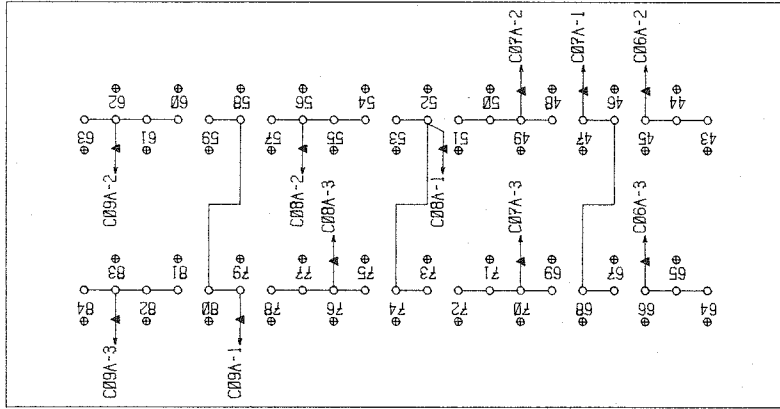

LOAD RESISTOR TRAY #2

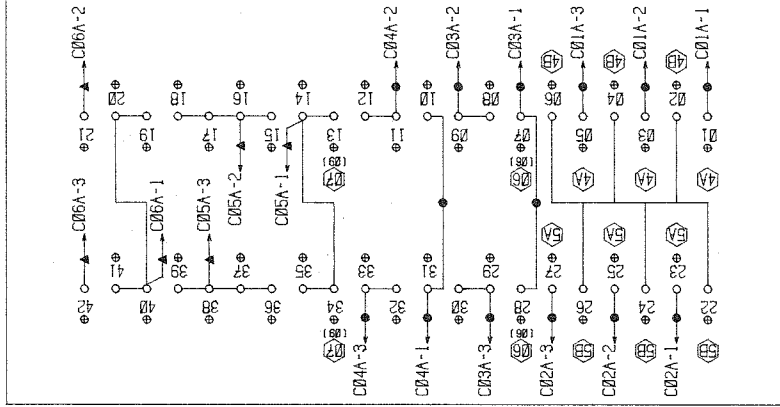

LOAD RESISTOR TRAY #1

LOAD BANK RIGHT SIDE  
TRAY FRONTS

NOTES

- ⊕ INDICATES MECHANICAL SUPPORT POINT FOR LOAD RESISTORS (NOT AN ELECTRICAL CONNECTION)
- ⊖ INDICATES BILL OF MATERIAL ITEM NUMBER (Ø) INDICATES QUANTITY FOR BA ITEM

**WIRE LEGEND**

- #16 AVG
- X- #14 AVG
- #12 AVG
- ▲ #8 AVG
- #6 AVG

**SCALE:** NONE APPROVED

**DATE:** 10/28/91

**MODEL:** TPLB LOAD BANK

**LOAD RESISTOR WIRING DETAIL - FRONT**

**REFERENCE:** V.O.# 910090

**LOADING TECHNOLOGY, INC.**  
14400 E. Firestone, Littleton, CO 80130

**DRAWN BY:** DPB

**RVSD:** 00/00/00

**DRAWING No.:** 910090-06

1421

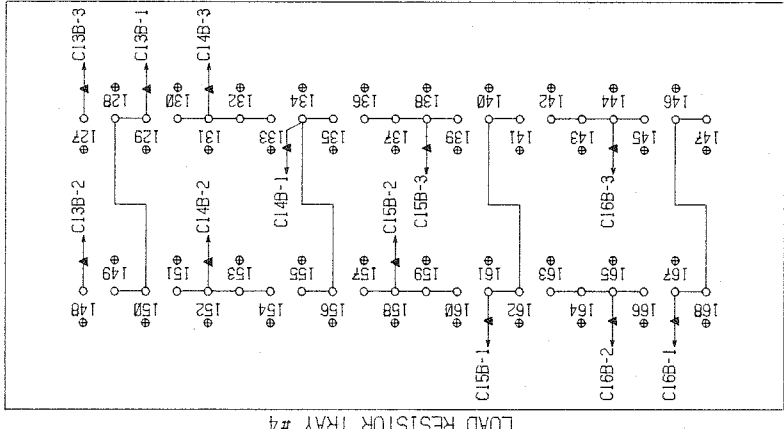

1421

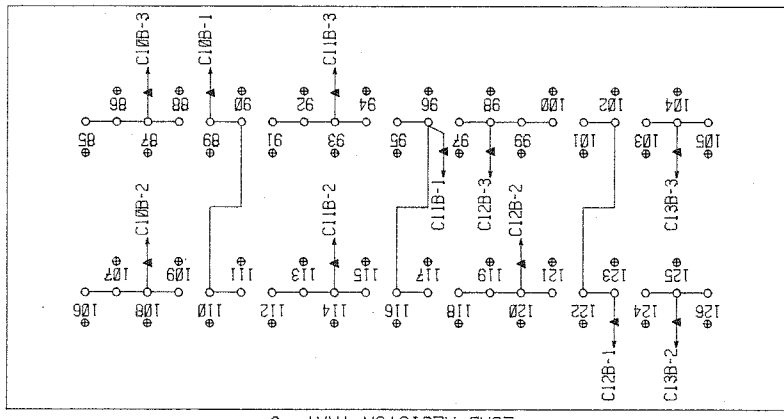

1421

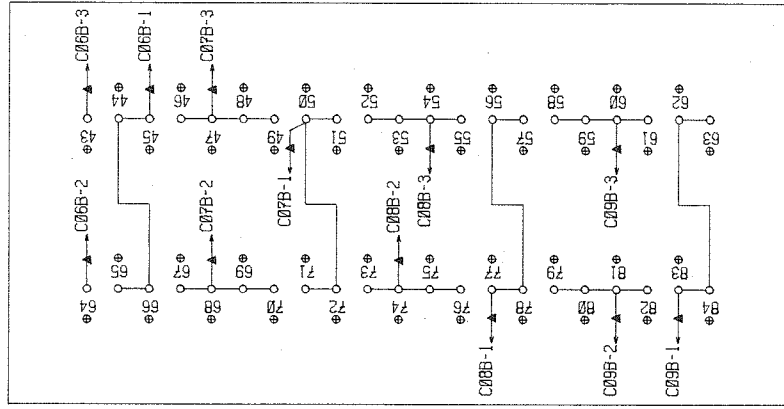

1421

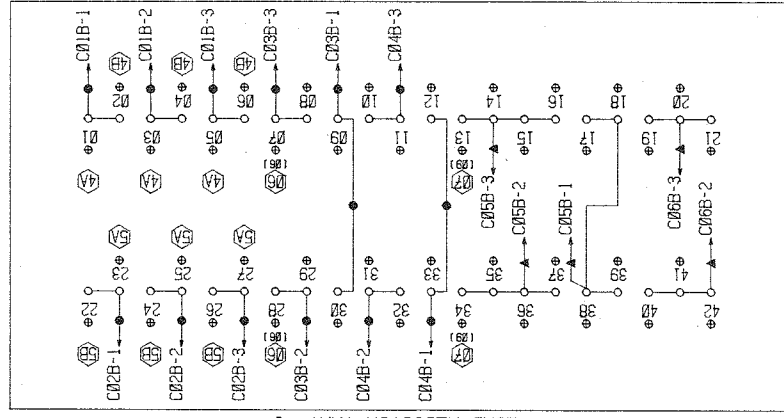

LOAD RESISTOR TRAY #1

LOAD RESISTOR TRAY #2

LOAD RESISTOR TRAY #3

LOAD RESISTOR TRAY #4

LOAD BANK LEFT SIDE

TRAY REARS

NOTES

- ⊕ INDICATES MECHANICAL SUPPORT POINT FOR LOAD RESISTORS (NOT AN ELECTRICAL CONNECTION)
- ⊖ INDICATES BILL OF MATERIAL ITEM NUMBER
- (0) INDICATES QUANTITY FOR BA ITEM

WIRE LEGEND

—	# 16 AWG
-X-	# 14 AWG
●	# 12 AWG
▲	# 8 AWG
■	# 6 AWG

**LOADTEC** LOAD TECHNOLOGY, INC  
 14400 E. Firestone, Littleton, CO 80138  
 SCALE: NONE APPROVED  
 DATE: 10/28/91  
 MODEL: IPLB LOAD BANK  
 DRAWN BY: DPB  
 RVS: 00/00/00  
 LOAD RESISTOR WIRING DETAIL - REAR  
 REFERENCE  
 V.O. # 910090  
 DRAWING No. 910090-07

# LOADTEC

LIMITED WARRANTY

## LOAD TECHNOLOGY, INC.

14400 E. FIRESTONE BLVD.  
LA MIRADA, CA 90638  
(714) 670-8628  
FACSIMILE #(714) 670-7368

LOADTEC, Load Technology Inc. warrants that its products are free from defects in material and/or workmanship under normal use and service. Its liability under this warranty shall be limited to twelve (12) months from date of shipment for all products and/or components except those associated with the "RESISTAR" Load Resistor assemblies which are limited to thirty six (36) months from date of shipment.

The "RESISTAR" Load Resistor assemblies extended warranty is limited to the failure of the Alloy wire, its termination, and workmanship of the assembly.

The warranty liability is limited to repair or replacement, at its option, at the factory or authorized service station with products and/or components returned with transportation costs prepaid. Returned products and/or components that are determined defective and within the warranty period will be repaired or replaced, and returned F.O.B. factory or repair station, freight charges collect.

This warranty does not cover incidental and consequential damages, nor does this warranty cover defects caused by misuse, improper installation, modifications, shipping damage, accident, or labor charges, service charges, or any liability except repair or replacement of the products and/or components.

This warranty is in lieu of any other warranties, expressed or implied.