

LOAD BANK TECHNICAL MANUAL

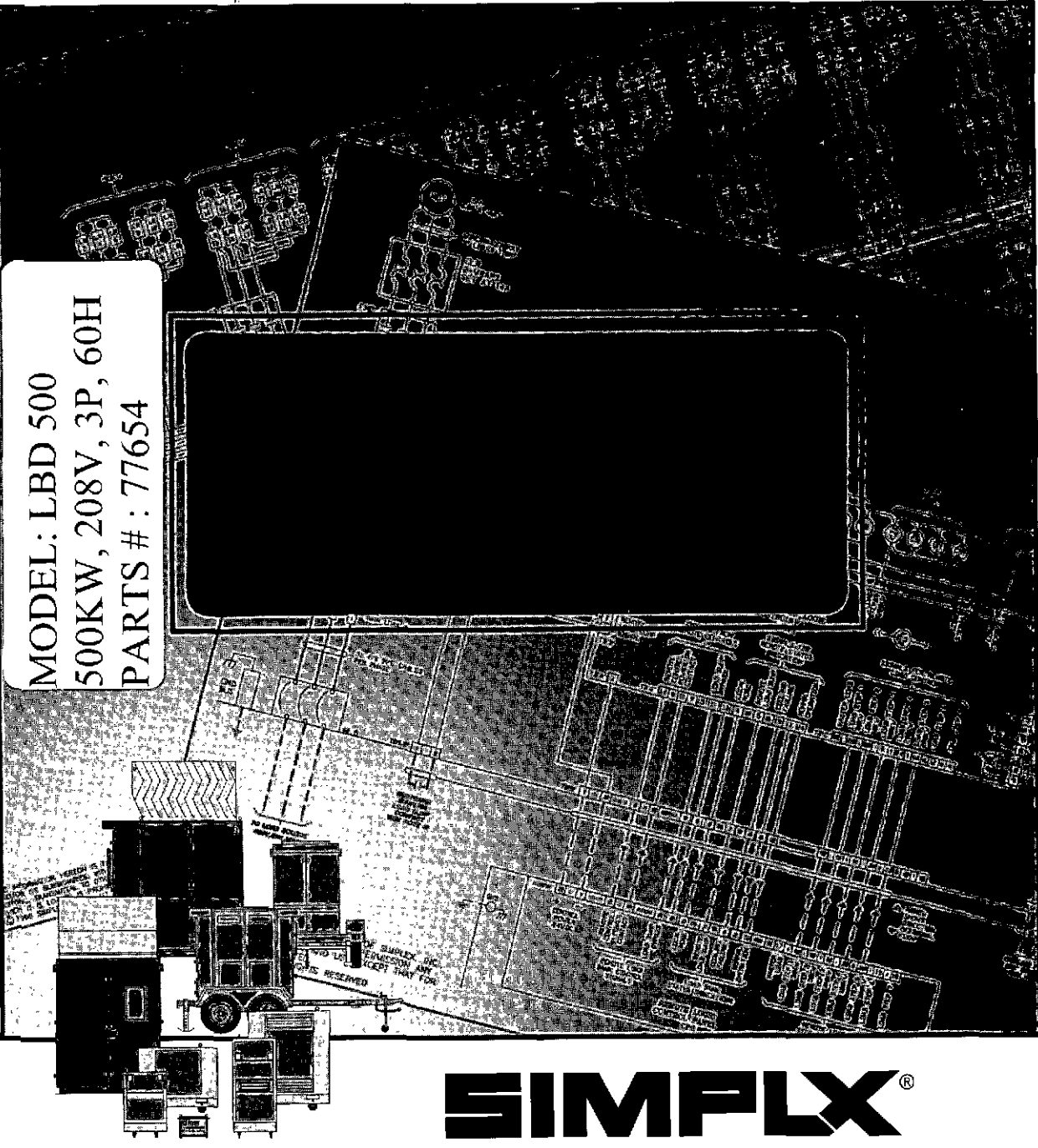

MODEL: LBD 500
500KW, 208V, 3P, 60H
PARTS # : 77654

SIMPLX[®]

LOAD BANKS & FUEL SUPPLY SYSTEMS

Simplex Inc., 1139 N. MacArthur Blvd., Springfield, IL 62702-2314
217-525-6995 (24 hr.) • Fax: 217-525-7984
www.simplexdirect.com



LOAD BANK TECHNICAL MANUAL

Customer: Katolight

Work Order: 53656-03-42

Model: LBD-500

June 03, 2003

The information herein is the property of Simplex, Inc. and/or its subsidiaries.
Without permission, any copying, transmitting to others, and other use
Except that for which it is loaned, is prohibited.
(File: Lbdman5mac.p65; Disk: SDCX152)

LOAD BANK SPECIFICATIONS SHEET

June 03, 2003
Customer: Katolight
Work Order: 53656-03-42
Model: LBD-500

Capacity:	500KW @ 1 PF		
Voltage:	208V		
Connection:	3 Phase 3 Wire		
Frequency:	60Hz		
Cooling:	Forced Air		
Fan/Control Power:	Internal 208:120V, 1ø, 60Hz L-N		
Max. Air Intake Temp.		Nominal Air Temp. Rise:	

Applicable Drawing Numbers and Special Notes:

Control Section	47B131775B
Load Section	47B131776A
Load Strapping	47B131777A
Parts Legend	47B131779A
Subpanel Layout	47BD131780B
Remote Pictorial	47BD131781
Load Bank Pictorial	47BD130907B

Contents

DESCRIPTION	2
Control System	3
Load System	3
PRIMARY INSPECTION	4
INSTALLATION	4
OPERATION	5
Manual	5
Automatic	5
CSR and TDR Example	5
PLC and CSR Example	6
Adjusting the CSR and TDR	6
Load Dump	7
FAILURE DETECTION	7
MAINTENANCE	7
Each Operation	7
Every 50 Hours or 6 Months	8
TROUBLESHOOTING	8
Cooling Failure Indicated	8
Test Meters Do Not Operate Properly	8
Some Load Steps Cannot Be Energized	8
DRAWINGS AND PARTS LIST	9
APPENDIX A - ABBREVIATIONS USED IN THIS MANUAL ..	10
APPENDIX B - CALCULATIONS & FORMULAS	12

DESCRIPTION

Simplex LBD Series Load Banks are a special form of stationary, resistive, forced air-cooled Load Bank which utilizes the air outflow of an engine radiator for cooling of the load elements. They are specifically designed to apply discrete, selectable electrical load to a power source while measuring the response of the generator to the applied load. They also provide a means for routine maintenance exercise to assure long term reliability and readiness of the standby generator. Exercise Load Banks eliminate the detrimental effects of unloaded operation of diesel engine generators.

Simplex LBD Series Load Banks are intended for use with water cooled engine generator sets equipped with unit mounted radiators. Simplex LBD-R Series are used with remote radiators. These Load Banks are built per customer specifications and can be installed in numerous ways, including direct bolted attachment to the radiator, mounting within an air duct, wall mounting over the air outflow opening, indoors or outdoors.

Power source testing is accomplished by applying resistive load steps at unity (1.0) power factor. See the Load Bank Specifications Sheet in the front of this manual for the rating of your Load Bank.

Load application is by magnetic contactor. All load branch circuits are protected by 200,000AIC class-T fuses.

The Control Panel contains the following controls and indicator lamps:

1. Over Temperature and Normal Operation lamps,
2. Control Power switch and/or pushbutton and
3. Master Load and load step switches.

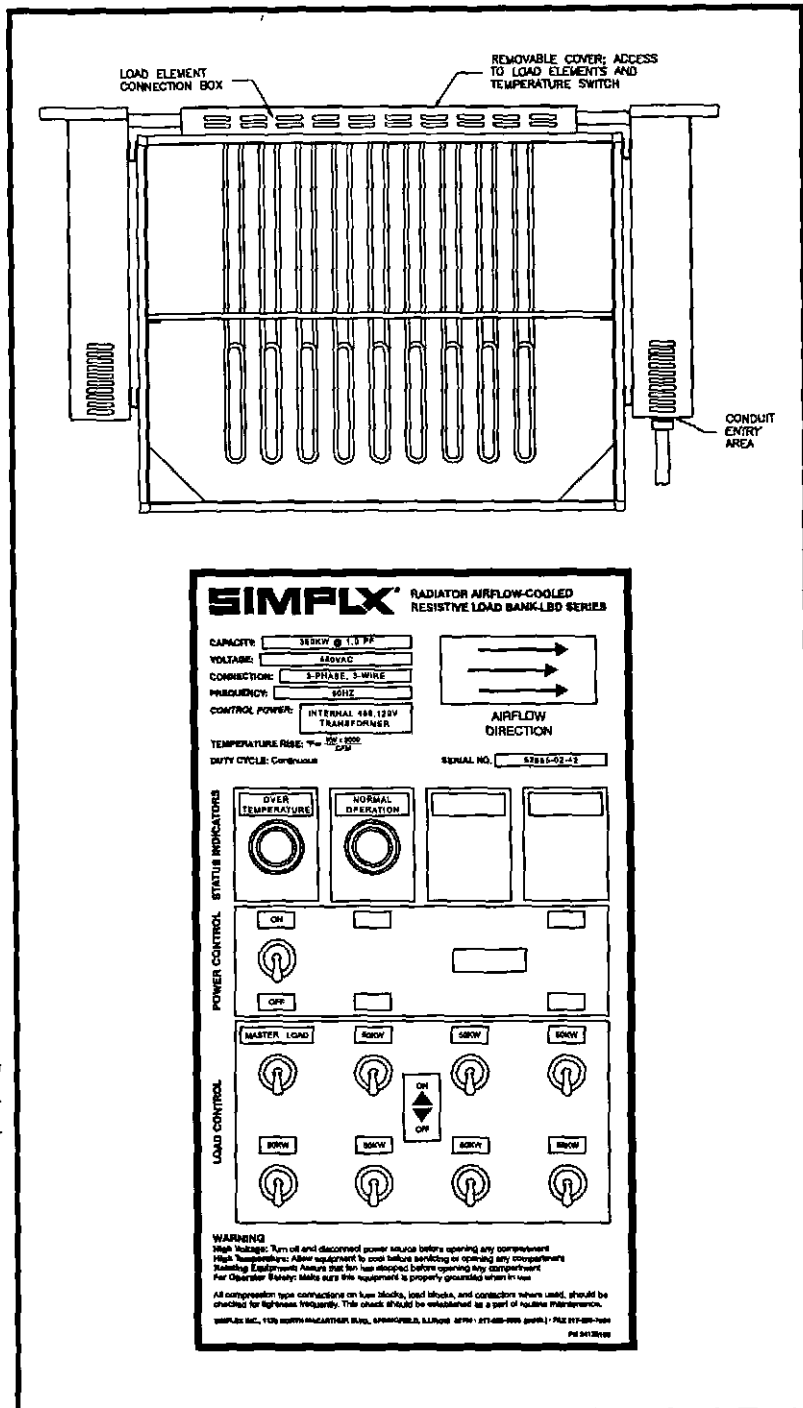

Parts of Typical Pictorial Drawing

This Load Bank is protected against cooling failures (high exhaust air temperature which could damage the Load Bank or present a safety hazard to the operator). The "Normal Operation" lamp illuminates when Control Power is available and the Cooling System is operating properly. When a cooling failure occurs the automatic safety features in the Control System immediately remove the load from the test source and illuminates the "Over Temperature" lamp. The malfunction must be corrected and the Load Bank must be reset by turning the Load Bank "Off" then "On" before the load can be re-applied.

The Load Bank consists of two principal systems:

1. Control System
2. Load System

CONTROL SYSTEM

The Control System allows the operator to apply a desired load to the test source and measure the response of the test source to the load. This system also contains the circuitry utilized to disconnect the Load Bank from the test source in the event of cooling failures and/or improperly positioned operating controls. The Control System consists of switches and lamps located on the Control Panel and logic circuitry located in the Control Section.

Control power (120V) is supplied to the Load Bank by one of the following methods:

1. test source via a control power transformer,
2. test source line to neutral, or
3. external source.

LOAD SYSTEM

Simplex LBD Series Load Banks are built up in fused branch circuits of not more than 70A each and protected by 600V, 200,000AIC class-T fuses. All wiring and devices within the branch circuit are rated in accordance with the fuse rating. Branch circuit fusing of the elements virtually eliminates the danger of short circuit of the load elements and consequent catastrophic damage to the Load Bank.

These Load Banks utilize either the Simplex Pow'r Rod or the Simplex Pow'r Web load elements. See Parts Legend Drawing for specific elements used.

Pow'r Rod Load Elements

Simplex Pow'r Rod Load Elements are UL recognized. These elements are totally enclosed, sealed and weather-proof. Pow'r Rod elements consist of nickel-chromium resistance wire electrically insulated and sealed within a metallic sheath. The hazard of electric shock to personnel and the danger of short circuit by foreign object penetration are reduced since the elements are electrically dead on the outside. They will not fatigue from engine or air-blast vibrations and will not sag or stretch if overheated. The sheath material is "incolloy", a rustproof nickel alloy with a very high temperature rating (1600°F). These elements do not require a cool down period.

References to Automatic Operation in this manual should be ignored if the Load Bank you are using is equipped with Manual Load Step Application only.

Powr-Web Load Elements

Simplex "Powr-Web" load elements are UL recognized. These elements conservatively operate at approximately half the maximum temperature rating of the alloy (1080°F vs. 1920°F). For example:

Alloy: FeCrAl

Ratings: 3333W@120V

4170W@139V

Connections: 120V wye (208V),
139V wye (240V, 3 ϕ),
277V wye (480V, 3 ϕ),
240 delta (240V, 3 ϕ), or
480 delta (480V, 3 ϕ).

These elements are rigidly supported by high-temperature, ceramic-clad, stainless-steel supports. Element-to-element short circuits are virtually eliminated.

PRIMARY INSPECTION

Preventative visual inspection of the shipping crate and Load Bank must be performed before installation. Physical or electrical problems due to handling and vibration may occur during shipment.

1. If crate shows any signs of damage examine the Load Bank in the corresponding areas for signs of initial problems.
2. Check the entire outside of the cabinet for any visual damage which could cause internal electrical or mechanical problems due to reduced clearance.

If any problems are observed during Primary Inspection call the Simplex Service Manager at 217-525-6995 (24hrs.)

3. Rotate and push all switches through all positions to ensure smooth operation.
4. Inspect the bottom of crate/enclosure for any components that may have jarred loose during shipment such as indicator light lenses, switch knobs, etc.
5. Visually inspect element chamber for foreign objects and mechanical damage.

INSTALLATION

1. Using the flanges provided attach the Load Bank with bolts per specifications. Bottom support for the load element enclosure is recommended.
2. Confirm the test source is properly grounded and ground the Load Bank to its own independent ground.
3. Confirm all load command switches are in the "Off" position.
4. Per load connection drawings cable the load source to the Load Bank. Consult NEC for proper wire size.
When cabling the Load Bank to the test source pull Load Bank access holes, install conduit connectors and conduits as needed.
5. Connect customer supplied contacts to load dump terminals shown on electrical drawing or jumper if not used.
6. Per drawings connect customer supplied alarm contacts.

References to Remote Control in this manual should be ignored if the Load Bank you are using is equipped with a Local Control Panel only.

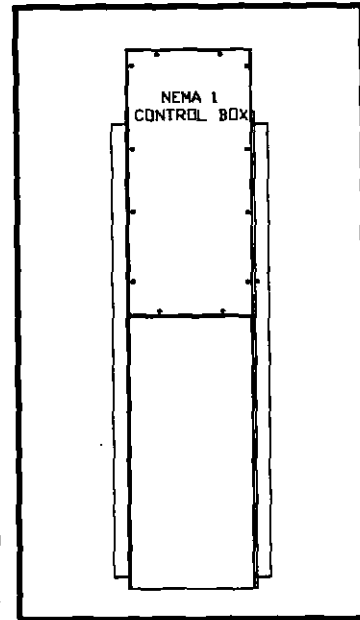

Part of Typical Pictorial Drawing



WARNING

Never operate or service a Load Bank that is not properly connected to an earthground.

OPERATION

1. Start-up generator or bring other test source on line.
2. Adjust power source voltage and frequency.
3. Place the "Control Power" switch in the "On" position or press the "On" pushbutton.
4. Verify the illumination of the "Normal Operation" lamp before proceeding.

MANUAL

5. Select the desired load steps by placing them in the "On" position.

LBD Load Banks equipped with only Manual Control have two-position load step switches: "On" and "Off".

LBD Load Banks equipped with Manual and Automatic Control have three-position load step switches: "Auto", "Off" and "Manual" – or – a Mode Selector switch with the following positions: "Auto", "Off", and "Manual"; and load step switches with "On" and "Off" positions.

6. Place the "Master Load" switch, if equipped, in the "On" position.

This simultaneously applies all of the load steps which are in the "On" position.

Trim is achieved by flipping the load steps "On" and "Off" while the "Master Load" is in the "On" position.

7. Adjust source voltage and load. Monitor as needed.

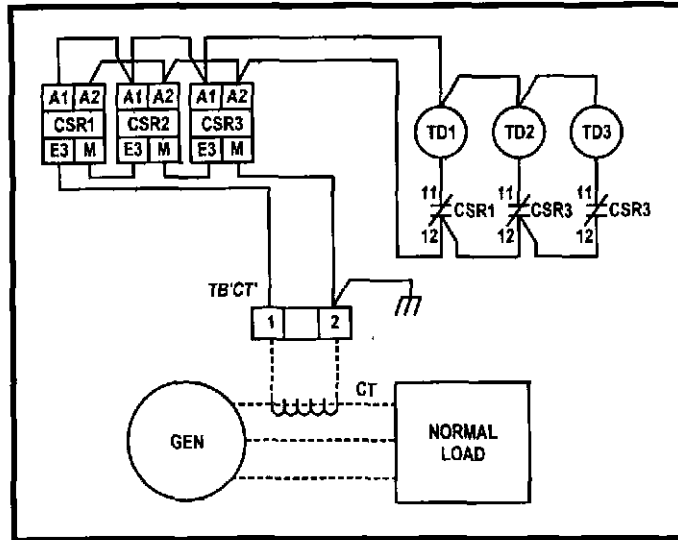

AUTOMATIC

Place all of the load step switches in the "Auto" position, or the Mode Selector Switch in the "Auto" position. In Automatic Mode, the Current Sensing Relays and Time Delay Relays (CSRs and TDRs), or a Programmable Logic Controller (PLC) in conjunction with (2) CSRs, automatically apply load as needed. These devices are factory set to maintain a minimum net load on the generator equal to approximately 60% of the generator's full load capability. Time delays between applying load steps are adjustable; see the specific prints supplied for your Load Bank.

CSR and TDR Example

60kW Load Bank with (3) 20kW Load Steps Serving a 100kW Generator:

While normal load (building load) is approximately 50kW or greater, the Load Bank will remain off-line, and add no load onto the generator.

When normal load drops below 50kW, the Load Bank will apply load step #1 (20kW) to the generator following a time delay determined by the setting of TDR1.

When normal load drops below 30kW, the Load Bank will apply load step #2 (20kW) to the generator following a time delay, bringing a total of 40kW of Load Bank load being applied to the generator.

Finally, as normal load drops below 10kW, the last step (20kW) is applied to the generator in the same manner as before, bringing total generator load to a minimum of 60kW.

Upon an increase in normal load, the reverse procedure is followed. The points at which the Load Bank steps drop out will be slightly higher than the pick-up points due to the built in hysteresis of the CSR relay. When calculating the operational points for a Load Bank with Automatic operation, Simplex assumes the normal load of the building will cause the generator to be operating at a 0.8 power factor, and adjusts the CSR pick-up points accordingly.

PLC and CSR Example

60kW Load Bank with 5kW Step Resolution Serving a 100kW Generator:

In this example, the (2) CSRs will be set so that CSR1 drops out (opens it's contacts) when *total* (including the Load Bank load) generator load increases above 50kW. CSR2 will be set to pick up (close it's contacts) when *total* generator load increases above 70kW. This establishes a "window" between 50kW and 70kW, inside of which the PLC takes no action to change Load Bank Load.

When *total* generator load is below 50kW, the PLC receives a signal from CSR1 to increase Load Bank load. The Load Bank will increase load in 5kW step increments, following time delays set according to Load Bank Control prints,

until total load is greater than 50kW. Note that if there is no normal load on the generator, the entire 60kW of Load Bank load may be applied due to the setpoints being calculated for a 0.8 powerfactor.

When total generator load is above 70kW, the PLC receives a signal from CSR2 to decrease Load Bank load. In the same fashion as above, the Load Bank will remove it's load until total generator load is below 70kW, or all Load Bank load is removed.

Adjusting the CSR and TDR

On the top of each Current Sensing Relay (CSR) dust cover there is a black adjustment knob (3/4 turn potentiometer) with an arbitrary 0.5-1.0 scale. Turn the knob clockwise for a higher current pick-up point and counterclockwise for a lower current pick-up point.

On the top of each Time Delay Relay (TDR) there is an adjustment knob (one turn potentiometer). These relays are adjustable from .1 to 30 seconds. Follow the directions on the white stickers for each potentiometer to adjust the set points.



WARNING

Do Not allow the Load Bank to operate unattended for extended periods.



WARNING

If an automatic test is interrupted by a Load Bank failure, do not reset the Load Bank until the source of the failure has been determined.

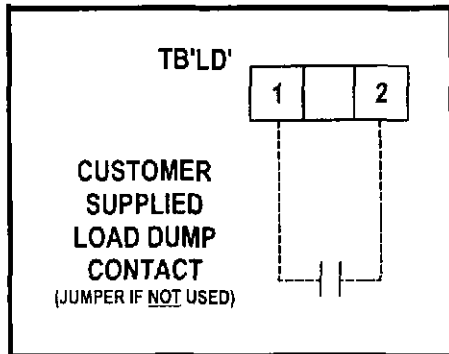

LOAD DUMP

Most Load Banks contain a Load Dump feature which de-energizes all applied load when customer supplied contacts open. Normally closed to run, they should be rated at 10A @ 120VAC. When these contacts open all applied load will be de-energized and the load section will be disabled. If desired, the customer may install automatic transfer switch contacts, a manual push-button or circuit breaker for this use. If Load Dump is not desired, the installer must jumper the contacts.

FAILURE DETECTION

If a "Failure" occurs the corresponding lamp will illuminate and the load will be de-energized. Before reapplying a load, the failure must be corrected and the system must be reset by turning the Load Bank "Off" then "On". This system includes the following components:

1. Exhaust Temperature Switch (EXTS),
2. Over Temperature Relay (OTR) and
3. Time Delay Relay (TDR).

⚠ WARNING ⚠

If a failure occurs the corresponding lamp will illuminate and the load will be de-energized. Before reapplying a load, the failure must be corrected and the system must be reset by turning the Load Bank "Off" then "On".

⚠ WARNING ⚠

Always remove all power from the load bus and all fan/control power before servicing the Load Bank. Never operate or service a Load Bank that is not properly connected to an earthground.

MAINTENANCE

The Load Bank has been designed to require minimum maintenance. All components have been chosen for a long, reliable life. Two basic intervals of maintenance are required: each operation and every 50 hours or 6 months (whichever comes first).

EACH OPERATION

The air intake openings, cooling chamber, and exhaust screens and louvers must be checked for any obstructions or foreign objects. Due to the high volume of air circulated, paper and other items can be drawn into the air intakes. During Load Bank operation insure that air is exiting from the exhaust side.

The load branches should be checked for blown fuses or opened load resistors. To check the fuses or load resistors, operate the Load Bank from a balanced 3-phase source and check the three line currents. The three cur-

**WARNING**

For continued safety and for maximum equipment protection, always replace fuses with one of equal rating only.

rent readings should be essentially the same. If a sizeable difference is noted one or more load fuses or load resistors may have malfunctioned.

**EVERY 50 HOURS
OR 6 MONTHS**

Check the tightness of the electrical connections. The expansion and contraction caused by Load Bank operation may result in loose connections. The vibrations caused by the generator set may also loosen electrical connections. If the Load Bank is transported "over the road", the electrical connections should be checked for tightness at a shorter-than-normal time interval. See "Primary Inspection".

TROUBLESHOOTING

This section is designed to aid the electrical technician in basic Load Bank system troubleshooting. All of the problems listed can be verified with a basic test meter and/or continuity tester. For safety reasons, when troubleshooting Load Bank systems always remove all test source power, control power, anti-condensation heater power, etc.

**COOLING FAILURE
INDICATED**

1. Over temperature sensor failure
2. Loss of genset exhaust
3. Air restriction (intake or exhaust)

**TEST METERS DO NOT
OPERATE PROPERLY**

1. Meter switch failure
2. Meter multiplier resistor inoperative
3. Improper positioning of meter selector switch
4. Current transformer or current transformer wiring failure
5. Test meter failure
6. Meter fuses open

**SOME LOAD STEPS
CANNOT BE ENERGIZED**

1. Inoperative load step switches
2. Open load step resistor(s)
3. *Inoperative load step relays*
4. Inoperative load step contactors
5. Open load step fuses

DRAWINGS AND PARTS LIST

The drawings included in this manual are the most accurate source of part numbers for your Load Bank. When ordering replacement parts for Simplex Load Banks, always consult the Parts Legend drawing. When contacting the Simplex Service Department always have your work order and drawing number ready for reference. The Load Bank Specifications Sheet in the front of this manual lists all of the drawings included in this manual. The Work Order Number and the Drawing Number are located on each drawing. A typical drawing legend and parts list is illustrated at right.

SIMPLX®		SPRINGFIELD, ILLINOIS
SCALE :	APPROVED BY :	DRAWN BY : BC
DATE : 4/9/99		REVISED :
RESISTIVE LOAD BANK 60KW, 480V, 3 ϕ , 60Hz		LBD-60 UL CONTROL/LOAD/LEGEND
W.O. # 35660-99-42		DRAWING NUMBER 47B100084

ITEM	QTY	PART #	DESIG.	DESCRIPTION
1	18	24309540	LR1-18	LOAD ELEMENTS, 3333W@277V OPERATING AT 3333W @ 277V 22", INCOLLOY SHEATH
2	2	13017100	C1, 2	CONTACTOR 50A, 600V, 3POLE 120VAC COIL
3	2	13906000	CF1, 2	FUSE, TIME DELAY 0.5A, 600V, 200KAIC
4	6	14075000	F1-6	FUSE, FAST ACTING 40A, 600V, 200KAIC
5	1	15011500	{CF1, 2}	FUSE BLDCK 30A, 600V, 2 POLE
6	2	15015500	{F1-6}	FUSE BLDCK 60A, 600V, 3 POLE
7	1	25649500	MLB	MAIN LOAD BLDCK, 175A 600V, 3-POLE, LINE CONS: 2/0-#14AWG, 1 CONN. / ϕ
8	1	25665000	TB'CT'	TERMINAL BLOCK 30A, 600V, 4 LINE
9	1	25671000	TB'A'	TERMINAL BLOCK 30A, 600V, 15 LINE
10	1	25450000 UL	T1	TRANSFORMER, 150VA 480/240V, 240/120V MACHINE TOOL CLASS
11	2	24771000	CPR DTR	GENERAL PURPOSE RELAY 10A, 240VAC, 3PDT 120VAC COIL
12	2	24891000	{CPR DTR}	RELAY BASE 11 PIN SCREW TRM
13	2	25301000	S1, 2	SWITCH DPDT, TOGGLE 6A @ 125VAC
14	2	25305100	S3, 4	SWITCH 3PDT, CENTER-OFF, TOGGLE 15A @ 125VAC
15	1	25309790	EXTS	EXHAUST TEMP SWITCH NO, CLOSE @ TEMP >295°F
16	2	24261500	L1-2	LIGHT-BASE 125V, NEQN, FOR B2A BULB

APPENDIX A - ABBREVIATIONS USED IN THIS MANUAL

Listed below are abbreviations of terms found on Simplex Load Bank Systems. When following a load bank drawing utilize this guide to define abbreviated system and component names. As this is a master list, drawings and text pertaining to your equipment may not contain all these terms.

AC - Alternating Current	FM - Frequency Meter-Monitors frequency of test source	LBA - Load Bank Available Relay
AIC - Ampere interrupting current-Maximum short circuit fault current a component can safely interrupt	FMC - Fan motor contactor-Controls power to fan motor	LFR - Loss of Flow Relay
AM - Ammeter	FMSW - Frequency meter switch	LM - Louver motor
AMSW - Ammeter selector switch-Selects any phase for current reading	FPS - Fan power switch-Used to energize cooling system	LMC - Louver motor contactor
CF - Control fuse	GFB - Ground fault breaker	LR - Load resistive element
CFM - Cubic feet per minute-Used to rate fan air flow capacity and load bank cooling requirement	GBTR - Ground breaker tripped relay	LX - Load reactive element
CFR - Cooling failure relay-Normally energized relay in cooling failure sub-system	GPM - Gallons per Minute	L1 - Line 1
CPC - Pilot contactor-Contactor that must be energized before load is applied.	HCF - Humidity Control Fuse	L2 - Line 2
CPF - Control power fuse	HCR - Humidity Control Relay	L3 - Line 3
CT - Current transformer-Transformer used in metering circuits	HMD - Humidistat	MCB - Main circuit breaker
DC - Direct current	HTR - Heater Strips	MF - Meter fuse
DHF - De-humidity control fuse	HVR - High voltage relay	MLB - Main line bus
DHR - De-humidity control relay	Hz - Hertz-Cycles per second, measurement of frequency	MOT - Motor
EXTS - Exhaust air temperature switch	IFCV - Incorrect fan/control voltage	NEMA - National Electrical Manufacturer's Association
FCB - Fan circuit breaker-Circuit breaker in series with fan control power	INTS - Intake air temperature switch	NSR - Normal Source Relay
FCVR - Fan control voltage relay-Normally energized relay on relay sub-panel	K - Relay coil/contact designation	ODP - Open, drip-proof-Refers to motor enclosure
	KVA - Kilovolt amperes	OVR - Overvoltage relay-Relay used in overvoltage failure system, located on relay sub-panel
	KVAR - Kilovolt amperes-reactive	OLR - Overload Relay-Used for motor protection
	KW - Kilowatts	OPR - Over Pressure Relay
	KWM - Kilowatt meter	OTR - Over Temperature Relay-Used in overtemperature failure system
	KWT - Kilowatt meter transducer	PF - Power factor-In resistive only loads expressed as Unity(1.0), in inductive loads expressed as lagging, in

capacitive loads expressed as leading

PLC - Programmable Logic Controller

PT - Potential Transformer

PAR - Control power available relay-Relay energized when control power is available

PFM - Power factor meter

PS - Pressure switch-Normally closed switch used to detect fan failure

PSI - Pounds per square inch

PSR - Pump Start Relay

RML - Remote Master Load Relay

RR - Run relay

RS - Remote Load Step Relay

RTM - Running time meter-Keeps time log of equipment use.

TB - Terminal block

TD-0 - Time Delay Timer-Delay on operate

TD-R - Time Delay Timer-Delay on release

TDR-0 - Time Delay Relay-Delay on operate

TDR-R - Time Delay Relay-Delay on release

TEFC - Totally enclosed, fan cooled-Refers to motor enclosure

TEAO - Totally enclosed, air-over-Refers to motor enclosure

UPS - Uninterruptable power source

V - Voltage

VO - Valve Operator

VOR - Valve Operator Relay

VSR - Voltage sensing relay

WFS - Water Flow Switch

WPS - Water Pressure Switch

WTS - Water Temperature Switch

XCB - Reactive load controlling circuit breaker

APPENDIX B - CALCULATIONS & FORMULAS

The following calculations are used to determine the actual kilowatt load being applied by the Load Bank, when line voltages and currents are known (at 1.0 power factor).

3 Phase

1. Read all three line currents and find the average reading.
2. Read all three line-to-line voltages and find the average reading.
3. Multiply the average current times the average voltage.
4. Multiply the answer of step #3 times the square root of 3 (1.732).
5. Divide the answer of step #4 by 1000. The answer is the actual kilowatts of load being applied by the Load Bank.

Single Phase

1. Determine the line current.
2. Determine the line-to-line voltage.
3. Multiply the line current times the line-to-line voltage.
4. Divide the answer of step #3 by 1000.
5. The answer of step #4 is the actual kilowatts being applied by the load bank.

EXAMPLES

Using line voltages and currents:

3 Phase

Current Readings	Voltage Readings
L1 = 249A	L1-L2 = 481V
L2 = 250A	L2-L3 = 479V
L3 = 254A	L3-L1 = 483V

$$\begin{aligned} \text{Average Current} &= \frac{L1A + L2A + L3A}{3} \\ &= \frac{249+250+254}{3} \\ &= 251A \end{aligned}$$

$$\begin{aligned} \text{Average Voltage} &= \frac{(L1V - L2V) + (L2V - L3V) + (L3V - L1V)}{3} \\ &= \frac{481 + 479 + 483}{3} \\ &= 481V \end{aligned}$$

$$\begin{aligned} \text{Kilowatts} &= \frac{\text{Volts} \times \text{Amps} \times 1.732}{1000} \\ &= \frac{481 \times 251 \times 1.732}{1000} \\ &= 209.1KW \end{aligned}$$

Single Phase

Current Reading: 150A Voltage Reading: 240V

$$\begin{aligned} \text{Kilowatts} &= \frac{\text{Volts} \times \text{Amps}}{1000} \\ &= \frac{150 \times 240}{1000} \\ &= 36.1KW \end{aligned}$$

The following calculations are used to determine the amount of current when the desired amount of kilowatts is applied at 1.0 power factor.

3 Phase

1. Multiply the desired amount of kilowatts to be applied by 1000.
2. Multiply the operating voltage times the square root of 3 (1.732)
3. Divide the answer of step #1 by the answer of step #2.
4. The answer of step #3 is the average line current with the desired kilowatts applied at 1.0 power factor.

Single phase

1. Multiply the desired amount of kilowatts to be applied by 1000.
2. Divide the answer of step #1 by the operating voltage.
3. The answer of step #2 is the average line current with the desired amount of kilowatts applied at 1.0 power factor.

The following calculations are used to determine a step kilowatt rating at other than a rated voltage. This is accomplished by referencing the load step to a KW value at a known voltage.

1. Determine the new unrated operating voltage.
2. Divide the new operating voltage by the reference voltage.
3. Square the answer of step #2.
4. Multiply the answer of step #3 times the reference kilowatt value of the load step which the new kilowatt rating is desired.
5. The answer of step #4 is the kilowatt rating of the load step at the new voltage.

EXAMPLES

When desired amount of kilowatts is applied at 1.0 PF:

3 Phase

Applied: 50KW Operating Voltage: 480V

$$\begin{aligned} \text{Amperage} &= \frac{\text{KW} \times 1000}{\text{Volts} \times 1.732} \\ &= \frac{50 \times 1000}{480 \times 1.732} \\ &= \frac{50,000}{831.36} \\ &= 60.1 \end{aligned}$$

Single Phase

Applied: 25KW Operating Voltage: 240V

$$\begin{aligned} \text{Amperage} &= \frac{\text{KW} \times 1000}{\text{Volts}} \\ &= \frac{25 \times 1000}{240} \\ &= \frac{25,000}{240} \\ &= 104.2 \end{aligned}$$

Determining step KW at other than rated voltage:

Applied: 80KW Operating Voltage: 450V
 Rated Voltage: 480V

$$\begin{aligned} \text{Step KW} &= (\text{Oper. Volt.} \div \text{Rated Volt.})^2 \times \text{Applied KW} \\ &= (450 \div 480)^2 \times 80 \\ &= .9375^2 \times 80 \\ &= 70.3 \end{aligned}$$

FORMULAS

		<u>Alternating Current</u>	<u>Direct Current</u>
Kilowatts	1 phase	$\frac{\text{Volts} \times \text{Amps} \times \text{PF}^*}{1000}$	$\frac{\text{Volts} \times \text{Amps}}{1000}$
	3 phase	$\frac{1.732 \times \text{Volts} \times \text{Amps} \times \text{PF}^*}{1000}$	

*Power Factor, expressed as decimal.
(Resistive Load Bank PF is 1.0)

Amperes (KW known)	1 phase	$\frac{\text{KW} \times 1000}{\text{Volts} \times \text{PF}}$	$\frac{\text{KW} \times 1000}{\text{Volts}}$
	3 phase	$\frac{\text{KW} \times 1000}{1.732 \times \text{Volts} \times \text{PF}}$	

KVA	1 phase	$\frac{\text{Volts} \times \text{Amps}}{1000}$	
	3 phase	$\frac{1.732 \times \text{Volts} \times \text{Amps}}{1000}$	

Amperes (KVA known)	1 phase	$\frac{\text{KVA} \times 1000}{\text{Volts}}$	
	3 phase	$\frac{\text{KVA} \times 1000}{1.732 \times \text{Volts}}$	

KVAR	1 phase	$\frac{\text{Volts} \times \text{Amps} \times \sqrt{1-\text{PF}^2}}{1000}$	
	3 phase	$\frac{1.732 \times \text{Volts} \times \text{Amps} \times \sqrt{1-\text{PF}^2}}{1000}$	

CODE	WIRE GAUGE	INSULATION TEMPERATURE RATING	WIRE COLOR	SIMPLEX PART NUMBER	APPLICATION
AA	16 AWG	105°C	BLACK	25518200	
AB	16 AWG	105°C	RED	25518100	
AC	16 AWG	105°C	BLUE	25518300	
AD	16 AWG	105°C	WHITE	25518000	
AE	16 AWG	150°C	BLACK	25515500	
AH	16 AWG	150°C	WHITE	25516500	
AZ	16 AWG	200°C	WHITE	25518500	
BM	14 AWG	105°C	GREEN	25525250	

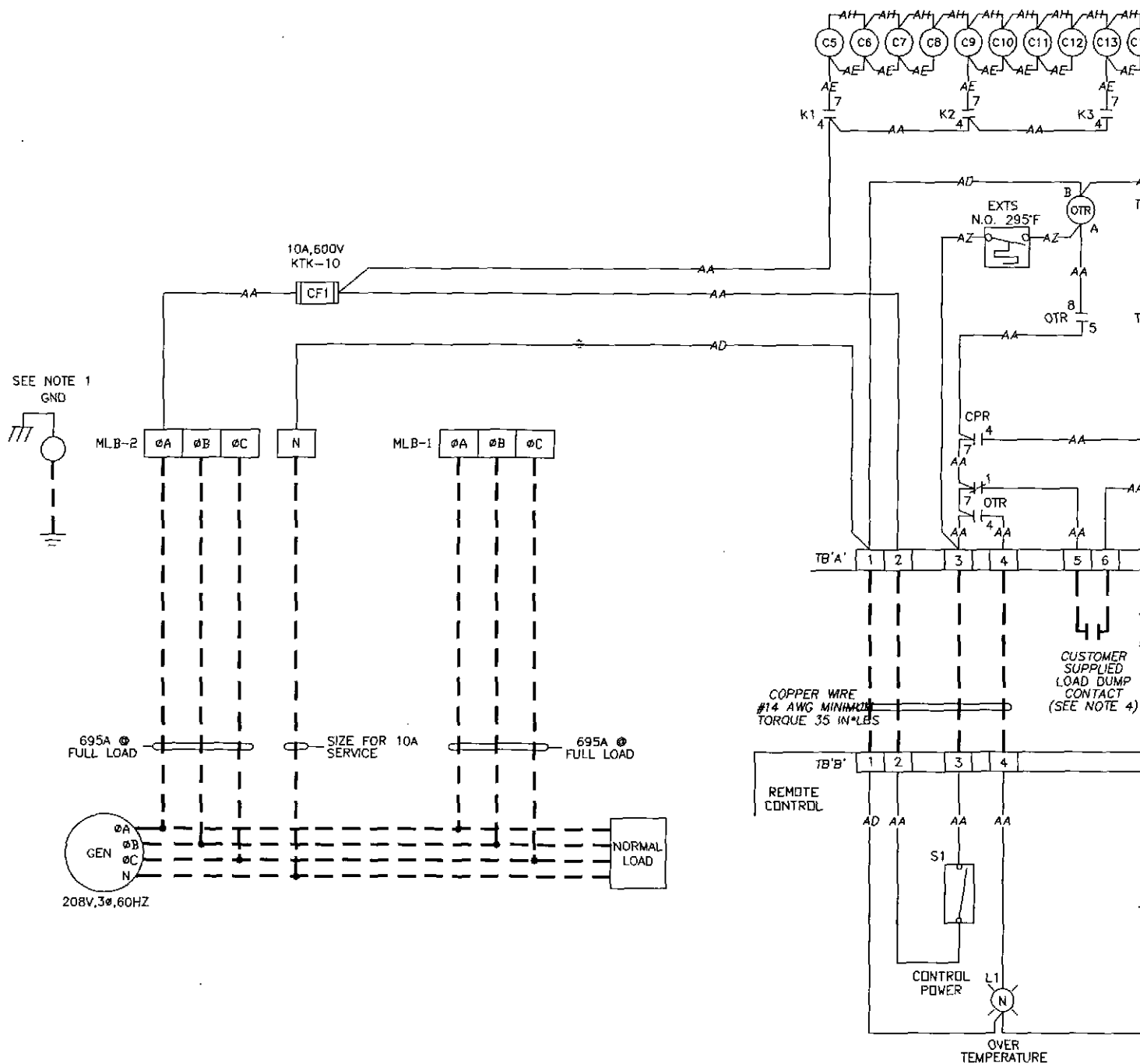

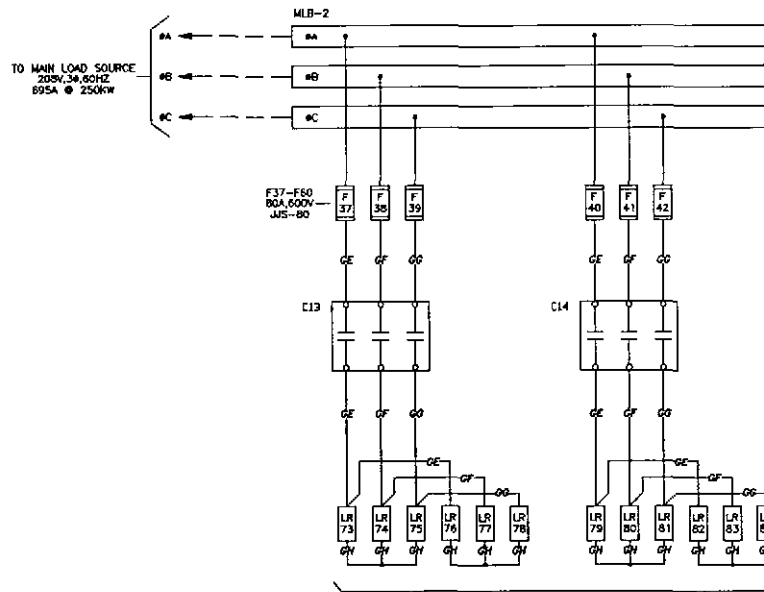
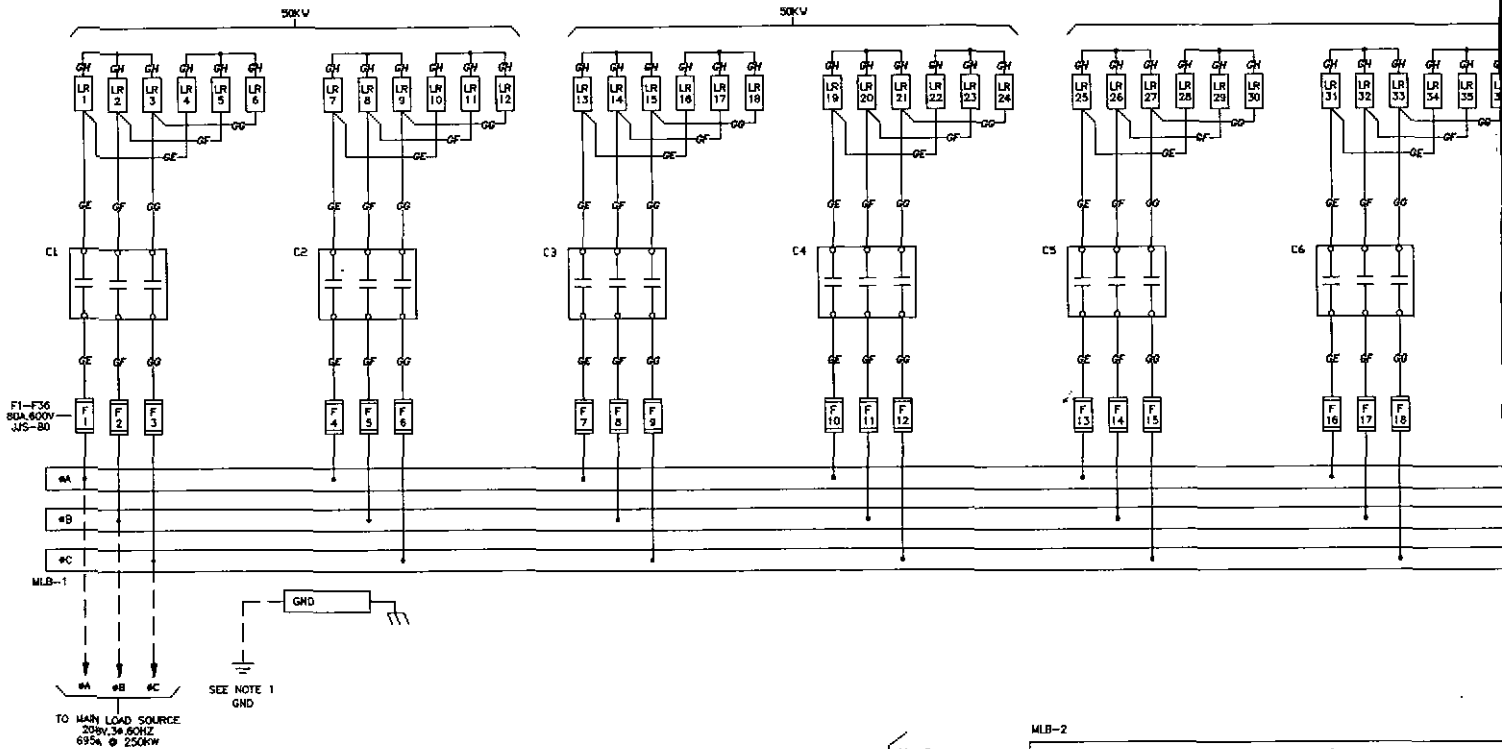

NOTES:
 1. UNIT MUST BE GROUNDED FOR OPERATOR'S SAFETY.
 2. DASHED LINES INDICATE WIRES NOT SUPPLIED BY SIMPLEX.

CODE	WIRE GAUGE	INSULATION TEMPERATURE RATING
GE	6 AWG	150°C
GF	6 AWG	150°C
GG	6 AWG	150°C
GH	6 AWG	150°C

100kW

100kW

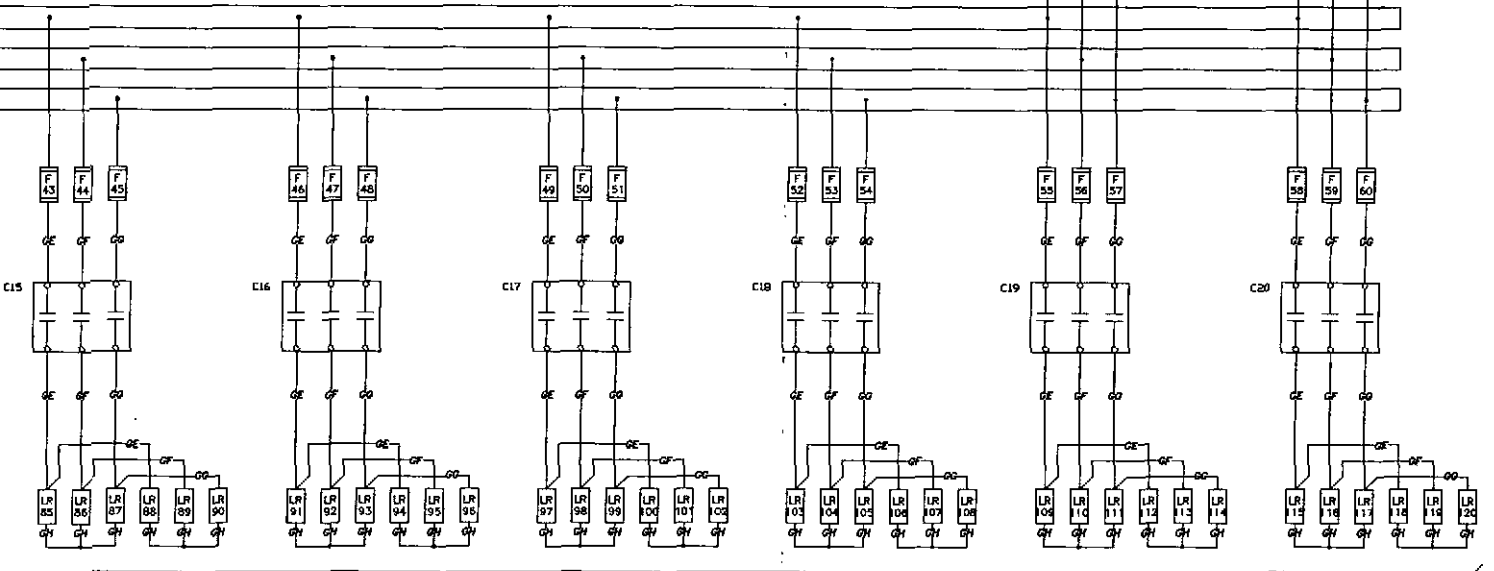
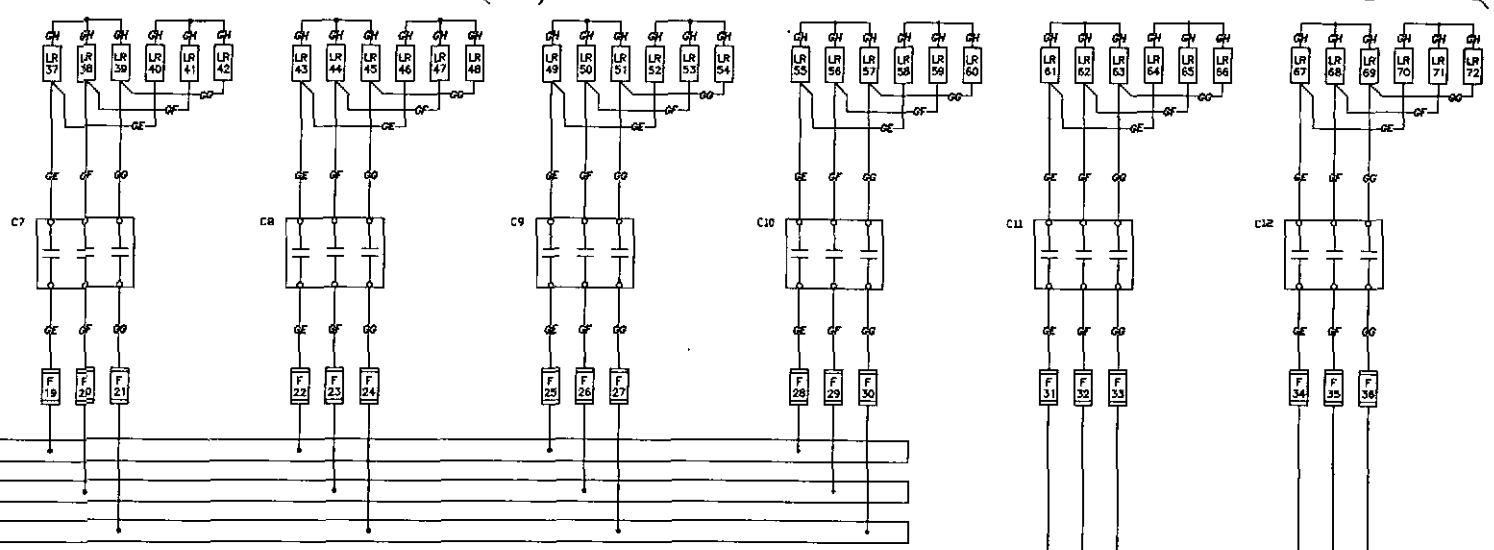

200kW

DISK S/N: 4468

A SPLIT MLB INTO MLB1,2	CJG
	4-24-03

SIMPLX SPRINGFIELD, ILLINOIS

SCALE : ~	APPROVED BY :	DRAWN BY : CJG
DATE : 04-02-03		REVISED : 1

RESISTIVE LOAD BANK LBD-500 UL
500KW, 208V, 3Ø, 60HZ LOAD SECTION

W.O. # 53656-03-42 DRAWING NUMBER 47B131776A

WIRE COLOR	SIMPLEX PART NUMBER	APPLICATION
BLACK	25538230	
RED	25538220	
BLUE	25538240	
WHITE	25538210	

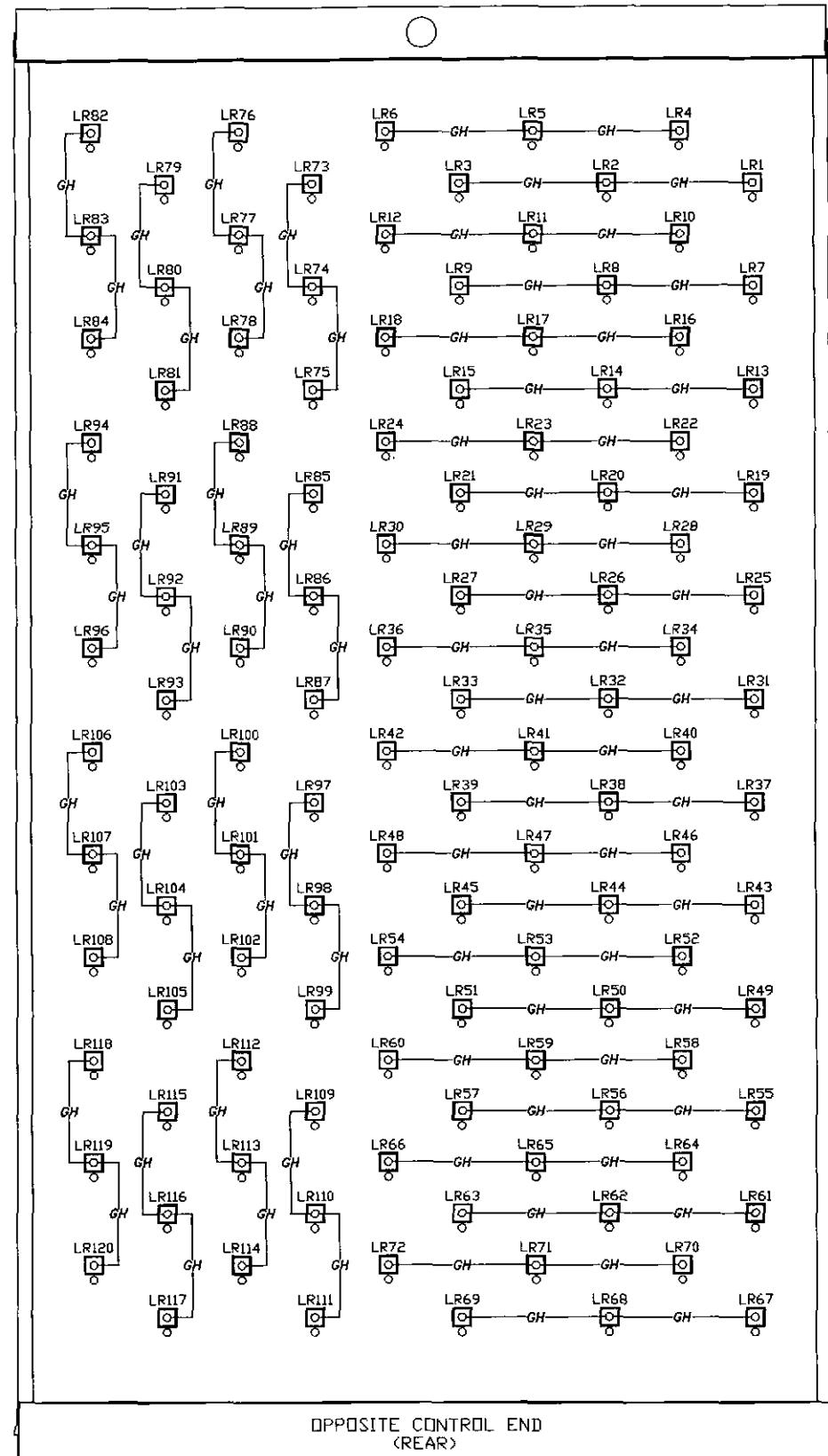

C1-0A
C2-0A
C3-0A
C4-0A
C5-0A
C6-0A
C7-0A
C8-0A
C9-0A
C10-0A
C11-0A
C12-0A

THE INFORMATION HEREON IS THE PROPERTY OF SIMPLEX, INC., AND/OR ITS SUBSIDIARIES. WITHOUT WRITTEN PERMISSION ANY COPYING, TRANSMITTAL TO OTHERS AND USE EXCEPT THAT FOR WHICH IT IS LOANED IS PROHIBITED.
© 2003 SIMPLEX, INC., ALL RIGHTS RESERVED

CODE	WIRE GAUGE	INSULATION TEMPERATURE RATING	WIRE COLOR
GE	6 AWG	150°C	BLACK
GF	6 AWG	150°C	RED
GG	6 AWG	150°C	BLUE
GH	6 AWG	150°C	WHITE

EXTS O

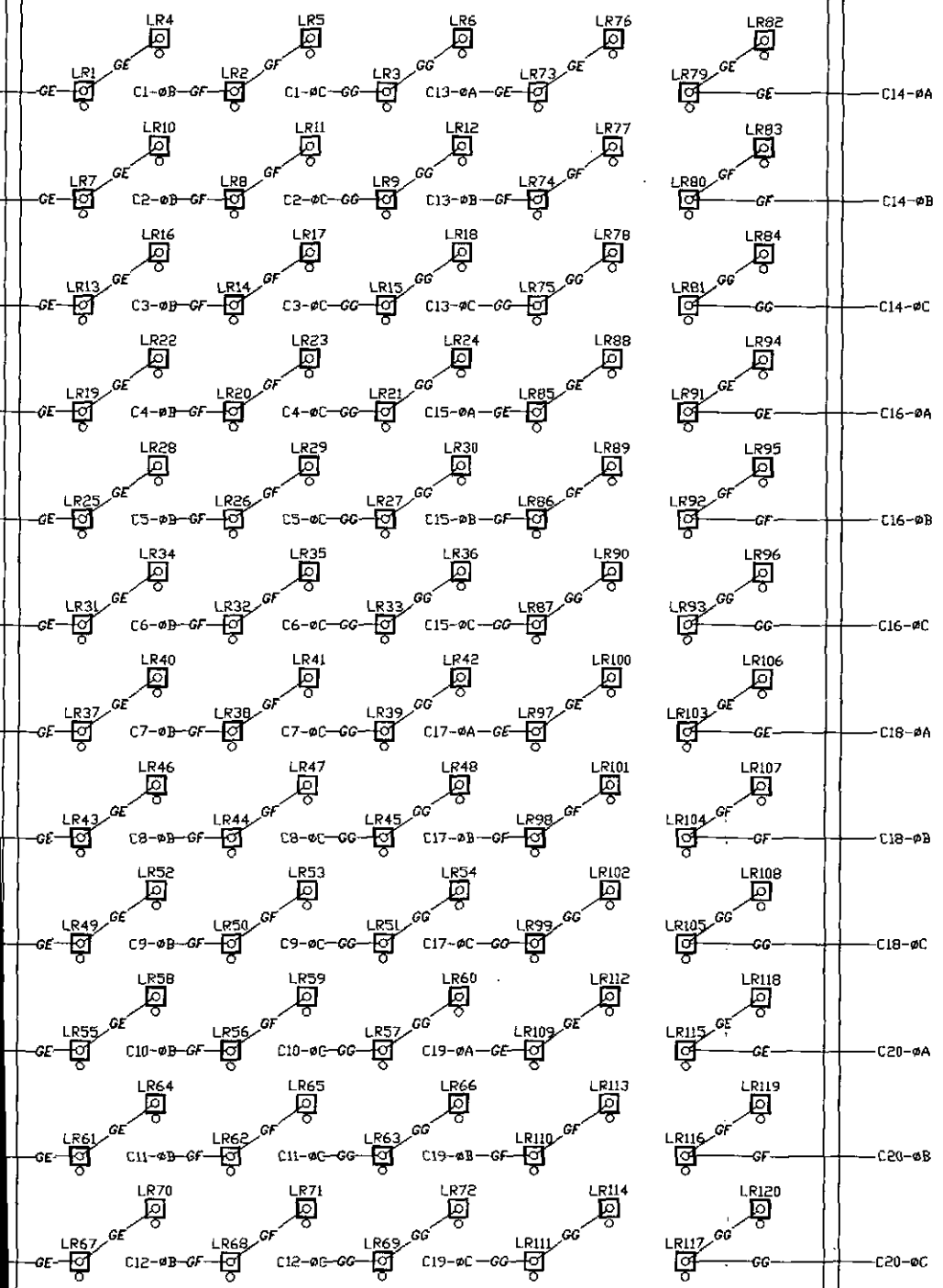

CONTROL END
(FRONT)

DISK S/N: 4468

A	MODIFIED ELEMENT LAYOUT	CJG
		5-27-03
SIMPLX		
SPRINGFIELD, ILLINOIS		
SCALE :	APPROVED BY :	DRAWN BY : CJG
DATE : 04-07-03		REVISED :
RESISTIVE LOAD BANK 500KW, 208V, 3 ϕ , 60HZ		LBD-500 UL STRAPPING
W.O. # 53656-03-42		DRAWING NUMBER 47B131777A

EX NUMBER	APPLICATION
230	
220	
240	
210	

ITEM	QTY.	PART #	DESIG.	DESCRIPTION
1	120	47B131778	LR1-LR120	LOAD ELEMENTS 4167W @ 120V POWR-WEB
2	20	13023710	C1-C20	CONTACTOR 75A, 600V, 3POLE 120VAC COIL
3	1	14044000	CF1	FUSE 10A, 600V, 100KAIC
4	60	14088500	F1-F60	FUSE 80A, 600V, 200KAIC
5	1	15010000	[CF1]	FUSEBLOCK 30A, 600V, 1 POLE
6	2	7BD44465B	MLB1,2 PHASE-A	MAIN LOAD BUS 0.250" X 3.000" X 30.500"
7	2	7BD44466B	MLB1,2 PHASE-B	MAIN LOAD BUS 0.250" X 3.000" X 34.750"
8	2	7BD44467D	MLB1,2 PHASE-C	MAIN LOAD BUS 0.250" X 3.000" X 39.000"
9	1	47BD63191	GND	GROUND BUS 0.250" x 3.000" x 12.250"
10	12	15390000	[MLB1,2]	ISOLATOR 2.000"
11	1	25663700	TB' MDT' N	TERMINAL BLOCK 30A, 300V, 3 LINE

ITEM	QTY.	PART #	DESIG.	DESCRIPTION
12	1	25672000	TB'A'	TERMINAL BLOCK 30A, 300V, 18 LINE
13	4	24771000	[DTR, CPR K1, K2]	GENERAL PURPOSE RELAY 10A, 3PDT, 240VAC 120VAC COIL
14	4	24891000	[DTR, CPR, K1, K2]	RELAY BASE 11 PIN SCREW TRM
15	7	25301000	S1-S7	SWITCH DPDT, TOGGLE
16	1	25309790	EXTS	EXHAUST TEMP SWITCH NO, CLOSE@TEMP GREATER THAN 295 DEGREES F
17	2	24261500	L1, L2	LIGHT-BASE 125V, PSB
18	2	24250500	[L1, L2]	LIGHT-BULB NEON, 125V
19	2	24272001	[L1, L2]	LENS, CLEAR
20	2	13850005	MOT1, 2	FAN MOTOR, AXIAL 115V, 0.25A, 50/60HZ 3400RPM, 245CFM, 6" DIA.

DISK S/N: 4468

A	SPLIT MLB INTO MLB1, 2	CJG 4-25-03
SIMPLX		SPRINGFIELD, ILLINOIS
SCALE :	APPROVED BY :	DRAWN BY : CJG
DATE : 04-03-03		REVISED : 1
RESISTIVE LOAD BANK 500KW, 208V, 3 ϕ , 60HZ		LBD-500 UL LEGEND
W.O. # 53656-03-42		DRAWING NUMBER 47B131779A

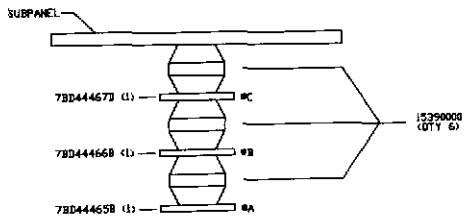

FUSE LAYOUT

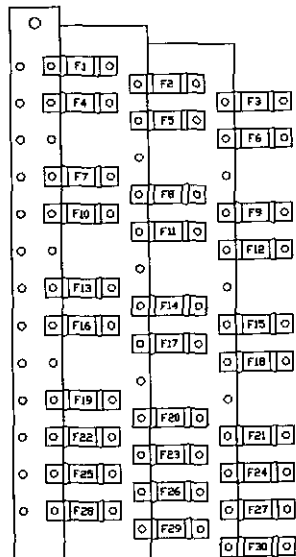

PHASE-C
78D444673
(QTY 1)

PHASE-B
78D444668
(QTY 1)

PHASE-A
78D444658
(QTY 1)

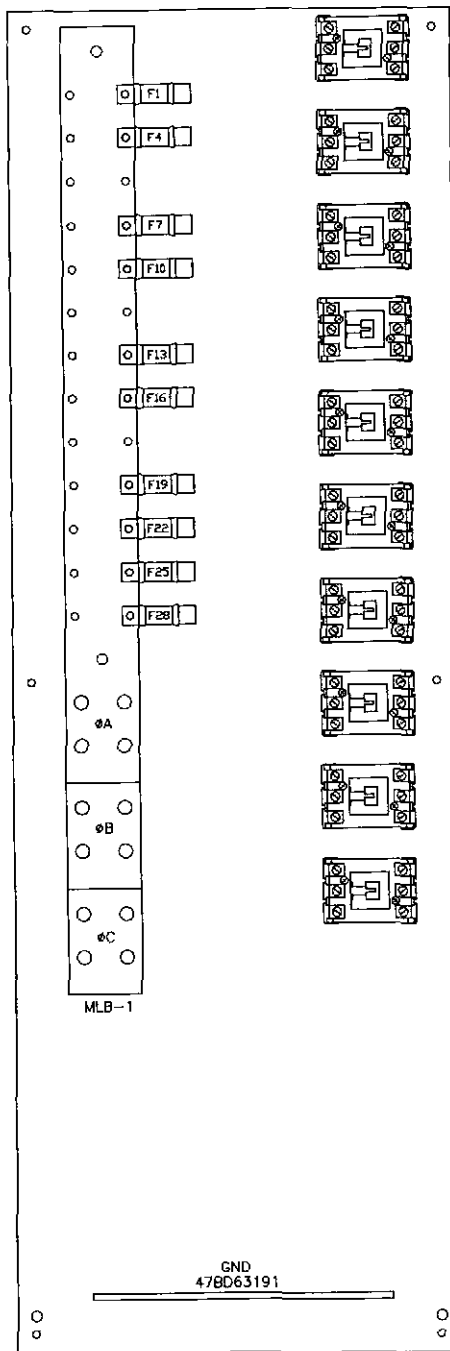

SIDEWALL SUBPANEL

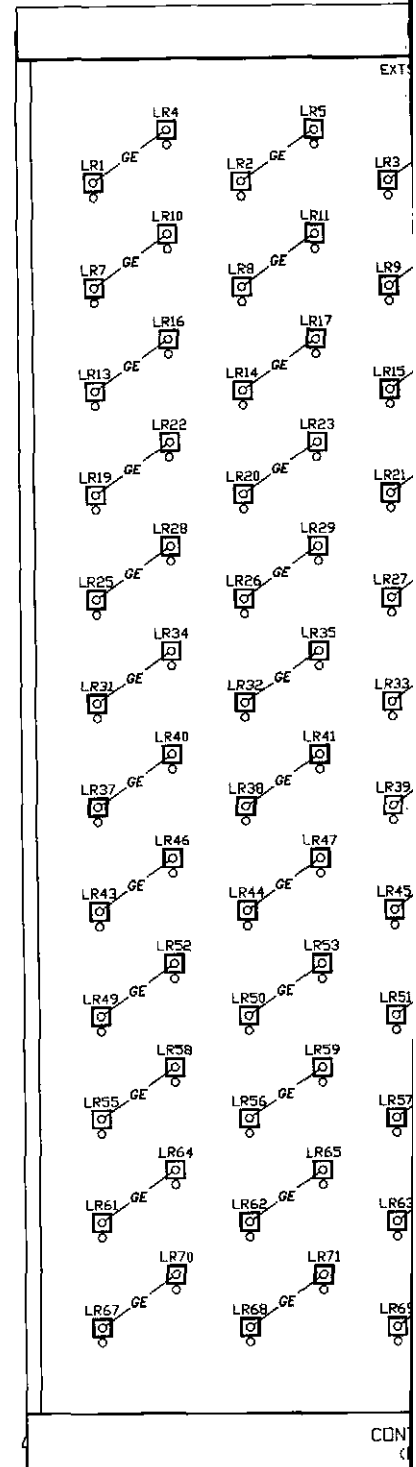

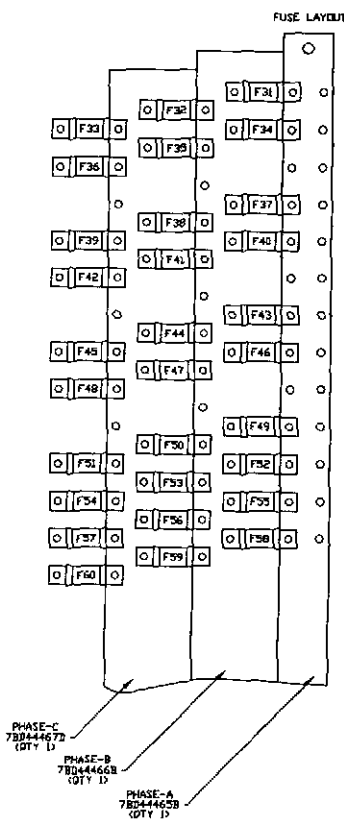
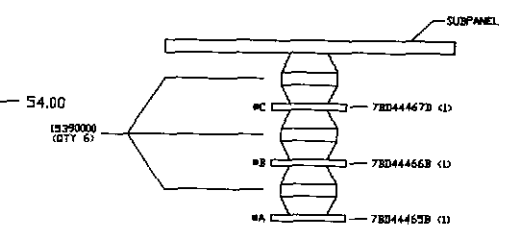
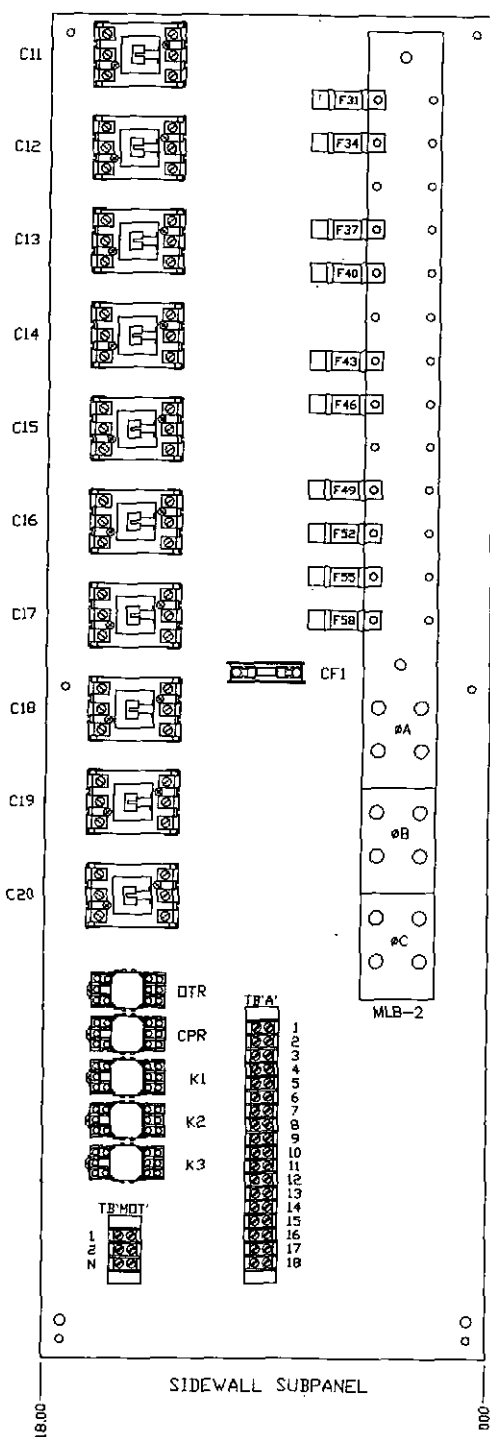
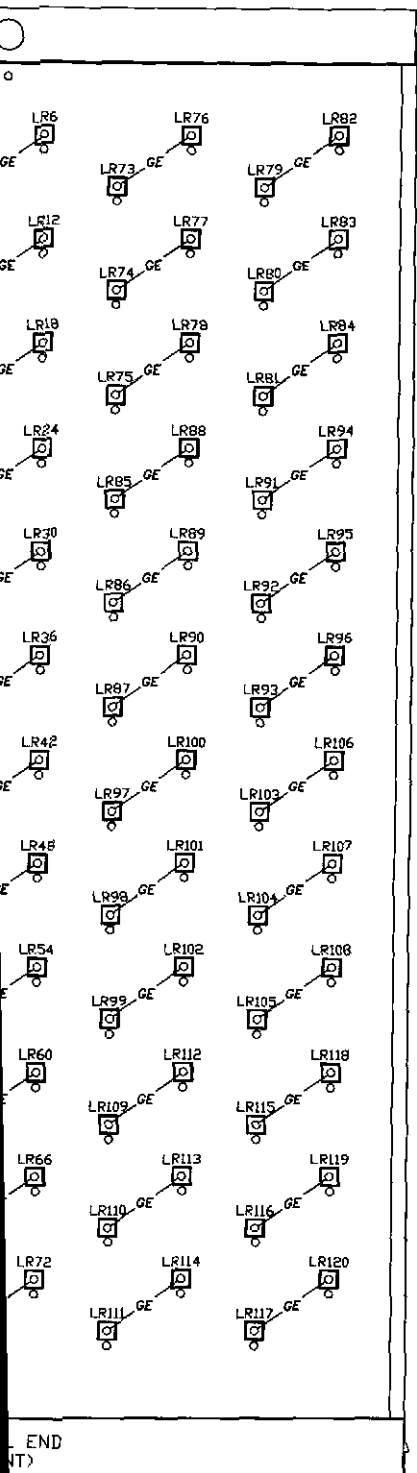

END
(NT)

SIDEWALL SUBPANEL

DISK S/N: 4468

B	MODIFIED ELEMENT LAYOUT	CJG
		5-27-03
A	WAS SINGLE SUBPANEL	CJG
		4-24-03

SIMPLX SPRINGFIELD, ILLINOIS

SCALE : _____ APPROVED BY : _____ DRAWN BY : CJG

DATE : 04-03-03 _____ REVISED : .5

RESISTIVE LOAD BANK LBD-500 UL
500KW, 208V, 3Ø, 60HZ SUBPANEL LAYOUT

W.O. #53656-03-42 DRAWING NUMBER
47BD131780B

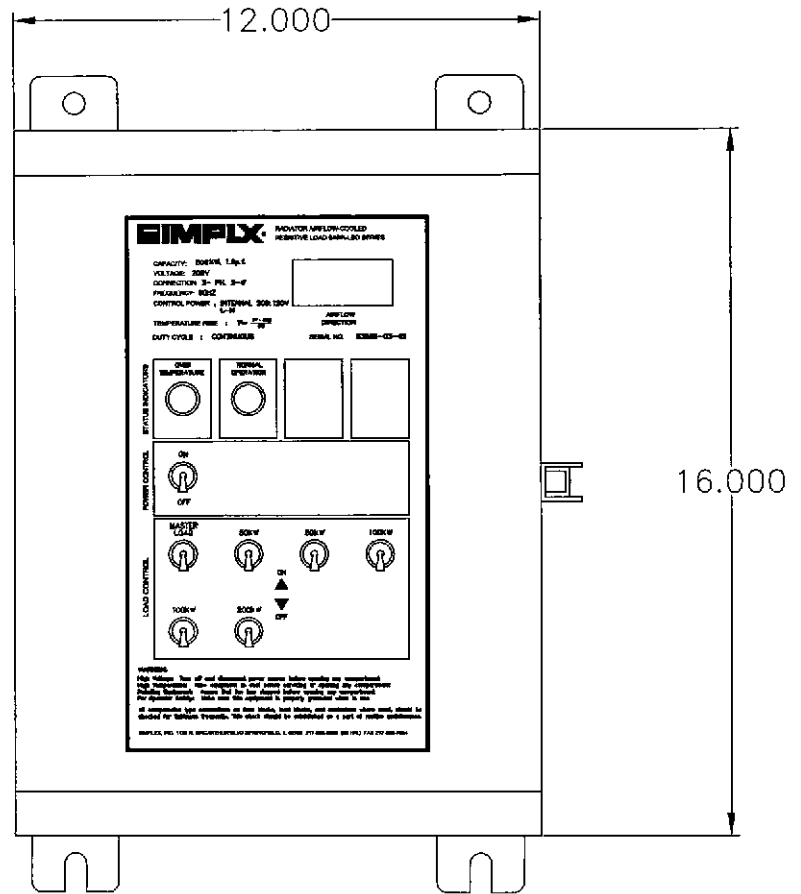
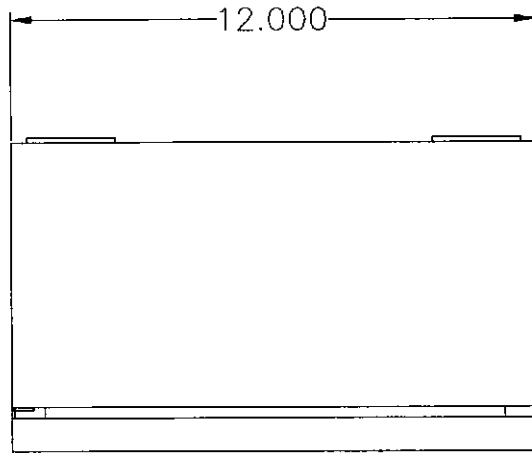

(CONTROLS LOCATED ON OUTER DOOR)

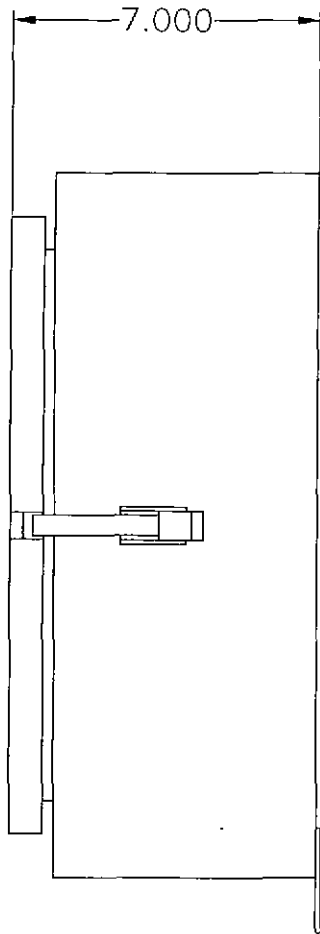
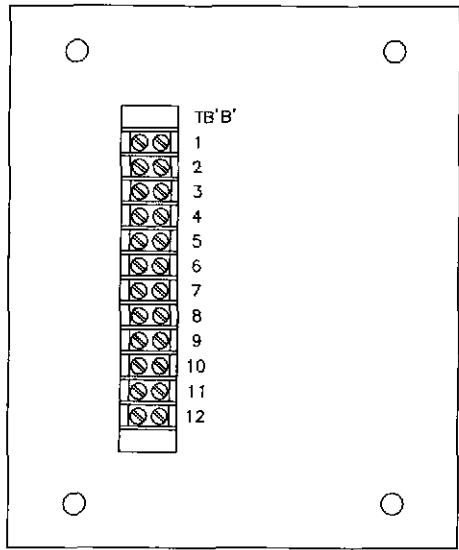

DISK S/N: 4468

SIMPLX		SPRINGFIELD, ILLINOIS
SCALE :	APPROVED BY :	DRAWN BY : CJG
DATE : 04-03-03		REVISED :
RESISTIVE LOAD BANK 500KW, 208V, 3 ϕ , 60Hz	LBD-500 UL REMOTE	
W.O. # 53656-03-42	DRAWING NUMBER 47BD131781	

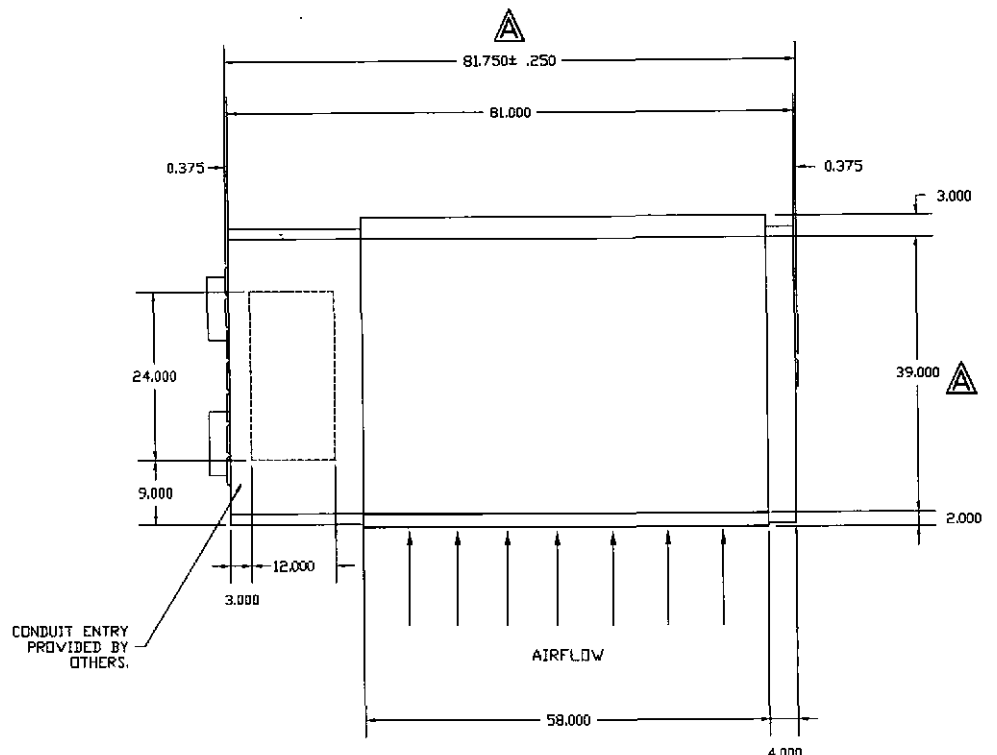

REMOVABLE COVER PROVIDES ACCESS TO CONTROL AND LOAD COMPONENTS

COOLING FAN AIR INLETS

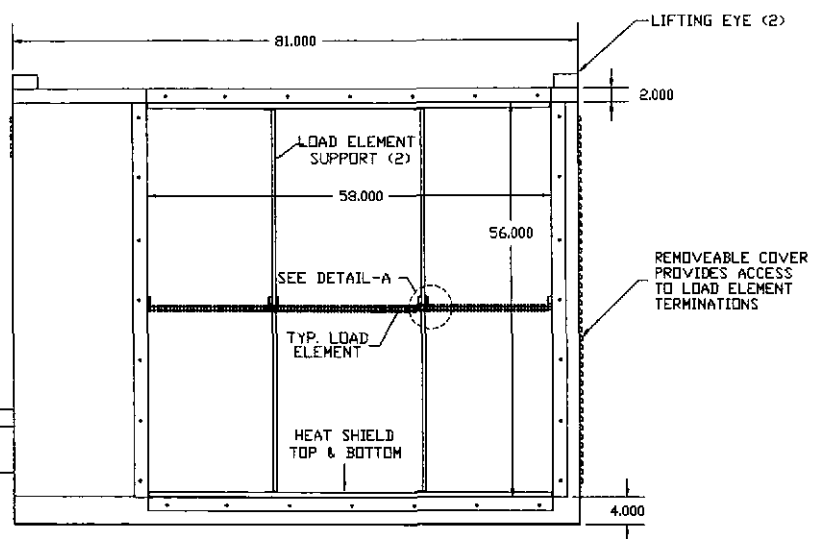
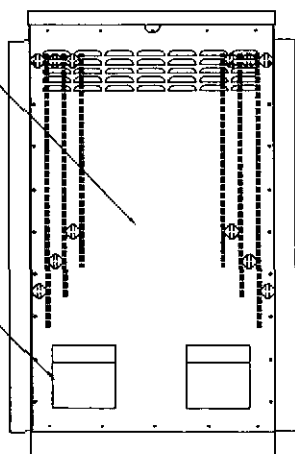

RADIATOR SIDE
(VIEW SHOWN LESS , EXHAUST SCREEN, & TOP COVER)

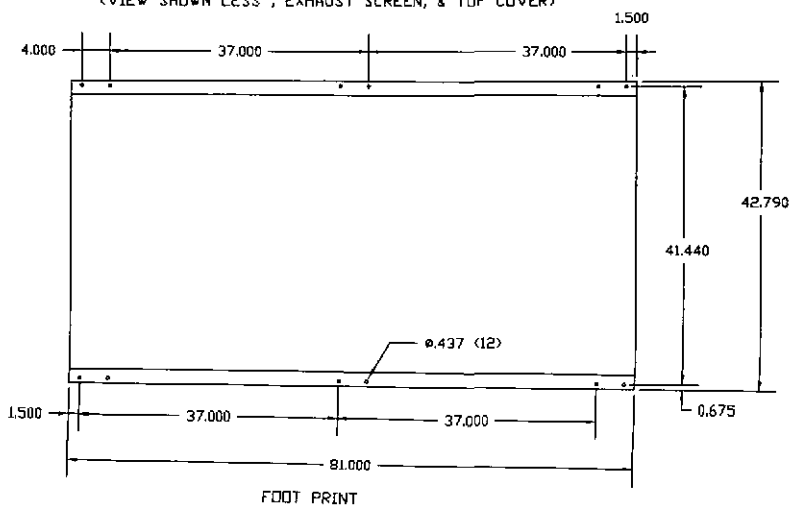

NOTES:

1. NEMA-3R ENCLOSURE
2. CONSTRUCTION:
 - A. DUCT FRAME AND ELECTRICAL ENCLOSURE
 - FORMED AND WELDED SHEET STEEL (12 GA. HRS.)
 - B. REMOVABLE COVERS
 - 14 GA. HRS. SHEET STEEL
3. FINISH:
 - ABRASIVE CLEANED OR CHEMICALLY CLEANED AND PHOSPHATIZED
 - FINISH COLOR : TAN
 - PRIMER: TILE CLAD WB EPOXY (24702501), PART A , B73A200, GRAY PRIMER (24702502), PART B , B73V200, CATALYST CENTURION POLYURETHANE
 - PAINT: TAN (24722500), B65V700 CATALYST
4. APPROXIMATE WEIGHT - 1,500 LBS.
5. LOAD BANK CONTROLS LOCATED REMOTELY.
6. LOAD BANK MUST BE INSTALLED USING ALL FLANGES TOP,BOTTOM,LEFT AND RIGHT. USE 3/8" GRADE-5 BOLTS FOR ATTACHMENT. BOTTOM SUPPORT FOR THE LOAD ELEMENT ENCLOSURE IS RECOMMENDED.
7. BOTTOM SUPPORT FOR THE CONTROL BOX IS REQUIRED
8. LATERAL AND VERTICAL DISPLACEMENT OF CONTROL BOX MUST BE PREVENTED. TEMPORARY SUPPORTS AND BRACES WILL BE REQUIRED.
9. TOP COVER MAY BE REMOVED TO ACCESS LIFTING EYES.

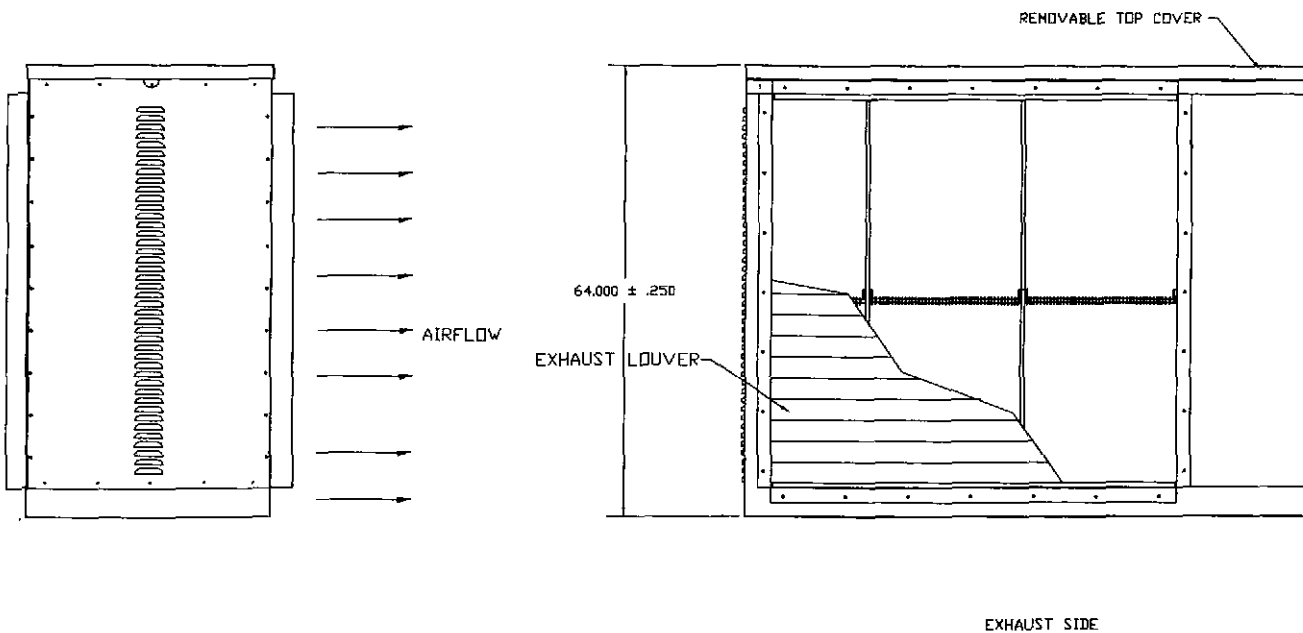
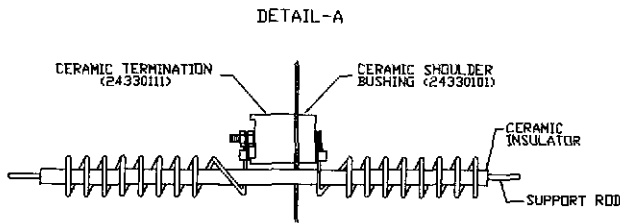

NOTE: LOAD BANK IS EQUIPPED WITH "SPLIT" LOAD BUS. CUSTOMER SUPPLIED LOAD CONNECTIONS MUST BE EVENLY SPLIT BETWEEN TWO SIDEWALL SUBPANELS.

DISK S/N:11127

B	REMOVED MOUNTING FEET	DRAWN BY : AJC
		DATE: 04/25/03
A	WAS 102.750±.250 & 33.000	DRAWN BY : AJC
		DATE: 04/24/03
SIMPLX ®		
		SPRINGFIELD, ILLINOIS
QTY	~	APPROVED BY :
DATE : 04/16/03		DRAWN BY : AJC
		TEMP #
RESISTIVE LOAD BANK		LBD 500
500KW,208V,3Ø,60HZ		DUCT MOUNT PICTORIAL
W.O. # 53656		DRAWING NUMBER
		47BD130907B