

# PARTS AND OPERATION MANUAL

## MQ POWER MODEL DCA-150SSJU WHISPERWATT™ GENERATOR

© COPYRIGHT 2001, MULTQUIP INC.

Parts List No. M3870300214  
Revision #3 (05/07/01)



**MULTQUIP INC.**  
18910 WILMINGTON AVE.  
CARSON, CALIFORNIA 90746  
310-537-3700  
800-421-1244  
FAX: 310-537-3927  
E-mail: [mq@multiquip.com](mailto:mq@multiquip.com)

**PARTS DEPARTMENT:**  
800-427-1244  
FAX: 800-672-7877  
**SERVICE DEPARTMENT:**  
800-835-2551  
FAX: 310-638-8046  
[www.multiquip.com](http://www.multiquip.com)



# **WARNING**



## **CALIFORNIA — Proposition 65 Warning**

**Diesel engine exhaust and some of its constituents are known to the State of California to cause cancer, birth defects and other reproductive harm.**

## **HERE'S HOW TO GET HELP**

*PLEASE HAVE THE MODEL AND SERIAL NUMBER  
ON-HAND WHEN CALLING*

### ***PARTS DEPARTMENT***

*800/427-1244 or 310/537-3700*

*FAX: 800/672-7877 or 310/637-3284*

### ***SERVICE DEPARTMENT***

*800/835-2551 or 310/537-3700*

*FAX: 310/638-8046*

### ***WARRANTY DEPARTMENT***

*800/835-2551 or 310/537-3700*

*FAX: 310/638-8046*

### ***MAIN***

*800/421-1244 or 310/537-3700*

*FAX: 310 - 537-3927*

# TABLE OF CONTENTS

Here's How To Get Help .....	3	Generator Assembly .....	60-61
Table Of Contents .....	4	Control Box Assembly .....	62-63
Parts Ordering Procedures .....	5	Engine & Radiator Assembly .....	64-67
Rules for Safe Operation .....	6-9	Engine Operating Panel Assembly .....	68-69
Towing Safety Precaution .....	10	Output Terminal Assembly .....	70-71
Trailer Safety Guidelines .....	11	Battery Assembly .....	72-73
Trailer Specifications .....	12-13	Muffler Assembly .....	74-75
Trailer Braking System .....	14-15	Fuel Tank Assembly .....	76-77
Trailer Tires & Suspension .....	16-17	Enclosure Assembly .....	78-81
Trailer Wire Diagram .....	18	Rubber Seal Assembly .....	82-83
Trailer Electronic Brakes Troubleshooting .....	19	Name Plate And Decals .....	84-85
Trailer Hydraulic Brakes Troubleshooting .....	20		
Operation and Safety Decals .....	21-22	Terms and Condition of Sale — Parts .....	86
DCA-150SSJU Specifications .....	23		

## MQPower DCA-150SSJU AC Generator

General Information .....	24
Major Components .....	26
Dimensions .....	27
Control Panel Descriptions .....	28-29
Engine Operating Panel Descriptions .....	30-31
Output Terminal Panel Descriptions .....	32-39
Installation .....	40-41
Pre Setup .....	42-45
Load Application .....	46
Generator Start-up Procedure, Manual .....	47-49
Generator Shut-Down Procedure .....	50
Maintenance .....	52-53
Engine Troubleshooting .....	54-55
Generator/Engine Troubleshooting .....	56
MPEC Troubleshooting .....	57
Explanation of Code in Remarks Column .....	58
Suggested Spare Parts .....	59

### NOTE

***Specification and part number  
are subject to change without  
notice.***

- Dealer account number
- Dealer name and address
- Shipping address (if different than billing address)
- Return fax number
- Applicable model number
- Quantity, part number and description of each part
- Specify preferred method of shipment:
  - UPS Ground
  - UPS Second Day or Third Day\*
  - UPS Next Day\*
  - Federal Express Priority One (please provide us with your Federal Express account number)\*
  - Airborne Express\*
  - Truck or parcel post

*\*Normally shipped the same day the order is received, if prior to 2PM west coast time.*

## Earn Extra Discounts when you order by FAX!

All parts orders which include complete part numbers and are received by fax qualify for the following extra discounts:

<u>Number of line items ordered</u>	<u>Additional Discount</u>
1-9 items	3%
10+ items**	5%

**Extra Fax Discount  
for Domestic USA  
Dealers Only**

**Up to 5%  
extra savings!**

**UPS  
Special**  
*For faxed orders only*

### Get special freight allowances when you order 10 or more line items via FAX! \*\*

- UPS Ground Service at no charge for freight
- PS Third Day Service at one-half of actual freight cost

No other allowances on freight shipped by any other carrier.

\*\*Common nuts, bolts and washers (all items under \$1.00 list price) do not count towards the 10+ line items.

\*DISCOUNTS ARE SUBJECT TO CHANGE\*

Fax order discount and UPS special programs revised June 1, 1995

**Now! Direct TOLL-FREE access  
to our Parts Department!**

Toll-free nationwide:

**800-421-1244**

Toll-free FAX:

**800/6-PARTS-7 • 800-672-7877**

# RULES FOR SAFE OPERATION

## CAUTION:



Failure to follow instructions in this manual may lead to serious injury or even death! This equipment is to be operated by trained and qualified personnel only! This equipment is for industrial use only.

The following safety guidelines should always be used when operating the DCA-150SSJU portable generator:

### GENERAL SAFETY

- **DO NOT** operate or service this equipment before reading this entire manual.



- This equipment should not be operated by persons under 18 years of age.



- **NEVER** operate this equipment without proper protective clothing, shatterproof glasses, steel-toed boots and other protective devices required by the job.

- **NEVER** operate this equipment when not feeling well due to fatigue, illness or taking medicine.



- **NEVER** operate this equipment under the influence of drugs or alcohol.



- **NEVER** use accessories or attachments, which are not recommended by MQ Power for this equipment. Damage to the equipment and/or injury to user may result.

- Manufacturer does not assume responsibility for any accident due to equipment modifications.

- Whenever necessary, replace nameplate, operation and safety decals when they become difficult read.

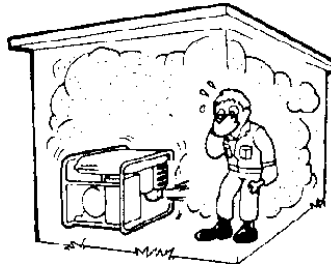
- Always check the machine for loosened threads or bolts before starting.

- **NEVER** touch the hot exhaust manifold, muffler or cylinder. Allow these parts to cool before servicing engine or generator.



- **High Temperatures** – Allow the engine to cool before adding fuel or performing service and maintenance functions. Contact with *hot* components can cause serious burns.

- The engine of this generator requires an adequate free flow of cooling air. Never operate the generator in any enclosed or narrow area where free flow of the air is restricted. If the air flow is restricted it will cause serious damage to the generator or engine and may cause injury to people. The generator engine gives off **DEADLY** carbon monoxide gas.



## CAUTION:



- Always refuel in a well-ventilated area, away from sparks and open flames.

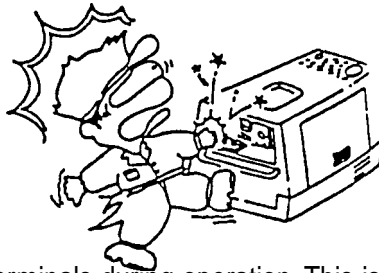


- Always use extreme caution when working with **flammable** liquids. When refueling, **stop the engine** and allow it to cool. **DO NOT** smoke around or near the machine. Fire or explosion could result from fuel vapors, or if fuel is spilled on a hot engine.

- **NEVER** operate the generator in an explosive atmosphere or near combustible materials. An explosion or fire could result causing severe *bodily harm or even death*.
- Topping-off to filler port is dangerous, as it tends to spill fuel.

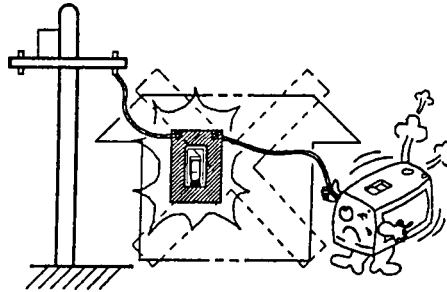
# RULES FOR SAFE OPERATION

## CAUTION:



■ **NEVER** touch output terminals during operation. This is extremely dangerous. Always stop the machine when contact with the output terminals.

## CAUTION:



■ **Backfeed** to a utility system can cause electrocution and/or property damage. Do not connect to any building's electrical system except through an approved device or after building main switch is opened.

## CAUTION:



■ **Never** use damaged or worn cables when connecting power tools or equipment to the generator. Make sure power connecting cables are securely connected to the generator's output terminals, insufficient tightening of the terminal connections may cause damage to the generator and electrical shock.

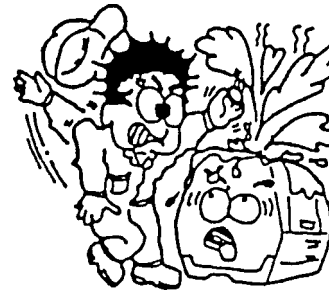
## CAUTION:



■ **DO NOT** touch or open any of the below mentioned components while the generator is running. Always allow sufficient time for the engine and generator to cool before performing maintenance.

### Radiator

1. **Radiator Cap** - Removing the radiator cap while the engine is hot will result in high pressurized, boiling water to gush out of the radiator, causing severe scalding to any persons in the general area of the generator.



2. **Coolant Drain Plug** - Removing the coolant drain plug while the engine is hot will result in hot coolant to gush out of the coolant drain plug, therefore causing severe scalding to any persons in the general area of the generator.
3. **Engine Oil Drain Plug** - Removing the engine oil drain plug while the engine is hot will result in hot oil to gush out of the oil drain plug, therefore causing severe scalding to any persons in the general area of the generator.

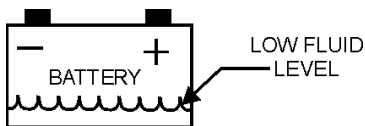
## Battery

### CAUTION:



- Never over fill the battery with water above the upper limit.

The battery contains acids that can cause injury to the eyes and skin. To avoid eye irritation, always wear safety glasses. Use well insulated gloves when picking up the battery. Use the following guidelines when handling the battery:



1. **DO NOT** drop the battery. There is the possibility of risk that the battery may explode.
2. **DO NOT** expose the battery to open flames, sparks, cigarettes etc. The battery contains combustible gases and liquids. If these gases and liquids come in contact with a flame or spark, an explosion could occur.
3. Always keep the battery charged. If the battery is not charged a buildup of combustible gas will occur.
4. Always keep battery charging and booster cables in good working condition. Repair or replace all worn cables.
5. Always recharge the battery in an open air environment, to avoid risk of a dangerous concentration of combustible gases.
6. In case the battery liquid (dilute sulfuric acid) comes in contact with **clothing or skin**, rinse skin or clothing immediately with plenty of water.
7. In case the battery liquid (dilute sulfuric acid) comes in contact with your **eyes**, rinse eyes immediately with plenty of water, then contact the nearest doctor or hospital, and seek medical attention.

- **NEVER** Run engine without air filter. Severe engine damage may occur.
- Always service air cleaner frequently to prevent carburetor malfunction.
- Always disconnect the battery before performing service on the generator.
- Always be sure the operator is familiar with proper safety precautions and operations techniques before using generator.
- Always store equipment properly when not in use. Equipment should be stored in a clean, dry location out of the reach of children.
- **DO NOT** leave the generator running in the manual mode unattended.
- **DO NOT** allow unauthorized people to operate this equipment.
- Always read, understand, and follow procedures in Operator's Manual before attempting to operate equipment.
- Refer to the **John Deere Engine Owner's Manual** for engine technical questions or information.

### Loading and Unloading (Crane)

- Before lifting, make sure the generator's lifting hook is secure and that there is no apparent damage to the generator itself (loose screws, nuts and bolts). If any part is loose or damaged, please take corrective action before lifting.
- Always drain fuel prior to lifting.
- Always make sure crane or lifting device has been properly secured to the hook of guard frame on generator.
- **NEVER** lift the machine while the engine is running.
- Use adequate lifting cable (wire or rope) of sufficient strength.
- When lifting the generator, always use the balanced center-point suspension hook and lift straight upwards.
- **NEVER** allow any person or animal to stand underneath the machine while lifting.
- When loading the generator on a truck, be sure to use the front and back frame bars as a means to secure the generator during transport.

## Transporting

- Always shutdown engine before transporting.
- Tighten fuel tank cap securely.
- Drain fuel when transporting generator over long distances or bad roads.
- Always tie-down the generator during transportation by securing the generator.
- If generator is mounted on a trailer, make sure trailer complies with all local and state safety transportation laws. See page 10 for basic towing procedures.

## Emergencies

- Always know the location of the nearest **fire extinguisher** and **first aid kit**. Know the location of the nearest telephone. Also know the phone numbers of the nearest **ambulance**, **doctor** and **fire department**.

## Maintenance Safety

- **NEVER** lubricate components or attempt service on a running machine.
- Always allow the machine a proper amount of time to cool before servicing.
- Keep the machinery in proper running condition.
- Fix damage to the machine immediately and always replace broken parts.
- Dispose of hazardous waste properly. Examples of potentially hazardous waste are used motor oil, coolant, fuel, and fuel filters.
- **DO NOT** use plastic containers to dispose of hazardous waste.
- **DO NOT** pour waste, oil, coolant or fuel directly onto the ground, down a drain or into any water source

# DCA-150SSJU — TOWING RULES FOR SAFE OPERATION

## Towing Safety Precautions

### CAUTION :



Check with your county or state safety towing regulations department before towing your generator.

To reduce the possibility of an accident while transporting the generator on public roads, always make sure the trailer (Figure 1) that supports the generator and the towing vehicle are in good operating condition and both units are mechanically sound.

The following list of suggestions should be used when towing your generator:

- Make sure the hitch and coupling of the towing vehicle are rated equal to, or greater than the trailer "gross vehicle weight rating" (GVWR).
- **ALWAYS** inspect the hitch and coupling for wear. **NEVER** tow a trailer with defective hitches, couplings, chains etc.
- Check the tire air pressure on both towing vehicle and trailer. Also check the tire tread wear on both vehicles.
- **ALWAYS** make sure the trailer is equipped with a "Safety Chain".
- **ALWAYS** attach trailer's safety chain to bumper of towing vehicle.
- **ALWAYS** make sure the vehicle and trailer directional, backup, brake, and trailer lights are connected and working properly.
- The maximum speed for highway towing is **45 MPH** unless posted otherwise. Recommended off-road towing is not to exceed **10 MPH** or less depending on type of terrain.
- Place *chocked blocks* underneath wheel to prevent **rolling**, while parked.
- Place *support blocks* underneath the trailer's bumper to prevent **tipping**, while parked.
- Use the trailer's hand winch to adjust the height of the trailer, then insert locking pin to lock wheel stand in place, while parked.
- Avoid sudden stops and starts. This can cause skidding, or jackknifing. Smooth, gradual starts and stops will improve gas mileage.
- Avoid sharp turns to prevent rolling.
- Remove wheel stand when transporting.
- **DO NOT** transport generator with fuel in tank.

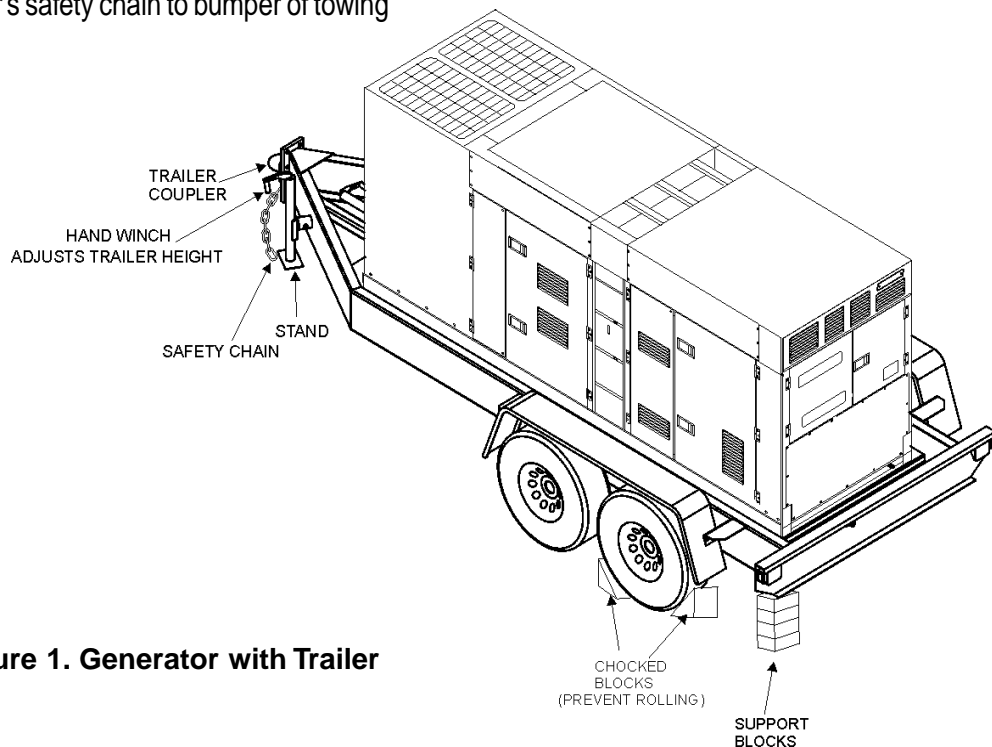


Figure 1. Generator with Trailer

## CAUTION:



**ALWAYS** make sure the trailer is in good operating condition. Check the tires for proper inflation and wear. Also check the wheel lug nuts for proper tightness.

### Explanation of Chart:

This section is intended to provide the user with trailer service and maintenance information. The service and maintenance guidelines referenced in this section apply a wide range of trailers. Remember periodic inspection of the trailer will ensure safe towing of the equipment and will prevent damage to the equipment and personal injury.

It is the purpose of this section to cover the major maintenance components of the trailer. The following trailer components will be discussed in this section:

- Brakes
- Tires
- Lug Nut Torquing
- Suspension
- Electrical
- Brake Troubleshooting Tables

Use the following definitions while reading Table 1.

1. **Fuel Cell** - Provides an adequate amount of fuel for the equipment in use. Fuel cells must be empty when transporting equipment.
2. **Braking System** - System employed in stopping the trailer. Typical braking systems are electric, surge, hydraulic, hydraulic-surge and air.
3. **GVWR**- Gross Vehicle Weight Rating (GVWR), is the maximum number of pounds the trailer can carry, including the fuel cell (empty).
4. **Frame Length** - This measurement is from the ball hitch to the rear bumper (reflector).
5. **Frame Width** - This measurement is from fender to fender.
6. **Jack Stand** - Trailer support device with maximum pound requirement from the tongue of the trailer.
7. **Coupler** - Type of hitch used on the trailer for towing.
8. **Tire Size** - Indicates the diameter of the tire in inches (10,12,14, etc.), and the width in millimeters (175,185,205, etc.). The tire diameter must match the diameter of the tire rim.
9. **Tire Ply** - The tire ply (layers) number is rated in letters; 2-ply,4-ply,6-ply, etc.
10. **Wheel Hub** - The wheel hub is connected to the trailer's axle.
11. **Tire Rim** - Tires are mounted on a tire rim. The tire rim must match the size of the tire.
12. **Lug Nuts** - Used to secure the wheel to the wheel hub. Always use a torque wrench to tighten down the lug nuts. See Table 4 and Figure 5 for lug nut tightening and sequence.
13. **Axle** - Indicates the maximum weight the axle can support in pounds, and the diameter of the axle expressed in inches (see Table 3 on page 17). Please note that some trailers have a double axle. This will be shown as 2-6000 lbs., meaning two axles with a total weight capacity of 6000 pounds.
14. **Suspension** - Protects the trailer chassis from shock transmitted through the wheels. Types of suspension used are leaf, Q-flex, and air ride.
15. **Electrical** - Electrical connectors (looms) are provided with the trailer so the brake lights and turn signals can be connected to the towing vehicle. See page 16 for proper wiring connections.
16. **Application** - Indicates which units can be employed on a particular trailer.

# DCA-150SSJU —TRAILER-SPECIFICATIONS

**Table 1. Specifications**

MODEL	APPLICATION	FUEL CELL	BRAKE SYSTEM	GVWR	FRAME LENGTH	FRAME WIDTH	JACK STAND
TRLR-10-15	TLG-12, DCA15, TLW-300	NO	NO	1900LBS	96"	50"	800LB. FULL TILT WHEEL
TRLR-10X	TLG-12, DCA15, TLW-300	NO	NO	1900LBS	96"	50"	800LB. FULL TILT WHEEL
TRLR-10XF	TLG-12, DCA15, TLW-300	51 GAL	NO	1900LBS	96"	50"	800LB. FULL TILT WHEEL
TRLR-225W	DCA-10	NO	NO	2200LBS	85"	42"	800LB. FULL TILT WHEEL
BLW-400	BLW-400	NO	ELECTRIC	2700LBS	W/MAST 154" W/O 124"	55" (78" TALL)	800LB. FULL TILT WHEEL
TRLR-15XF	DCA-15	41 GAL	NO	2700LBS	124"	55"	800LB. FULL TILT WHEEL
TRLR-50X	DCA-25	NO	NO	2700LBS	124"	55"	800LB. FULL TILT WHEEL
TRLR-50XF	DCA-25	41 GAL	NO	2700LBS	124"	55"	800LB. FULL TILT WHEEL
TRLR-25SBT	DCA-25	NO	NO	2990LBS	120"	66"	800LB. FULL TILT WHEEL
TRLR-70W	DCA-45, -60, 70	NO	SURGE	7000LBS	186"	77"	2000LB. FLAT PAD
TRLR-70X	DCA-45, -60, 70	OPT	SURGE	7000LBS	138"	66"	2000LB. FLAT PAD
TRLR-70XF	DCA-45, -60, 70	53 GAL	SURGE	7000LBS	138"	66"	2000LB. FLAT PAD
TRLR-100XF	DCA-100, 125	150 GAL	HYDRAULIC SURGE	7000LBS	190"	76"	2000LB. FLAT PAD
TRLR-85/125	DCA-85, 100, 125	145 GAL	HYDRAULIC	10000LBS	186"	77"	2000LB. FLAT PAD
TRLR-150XF	DCA-150, 180	200 GAL	HYDRAULIC SURGE	11160LBS	204"	84"	5000 LB. FLAT PAD
TRLR-220XF	DCA-220	250 GAL	HYDRAULIC SURGE	14000LBS	222"	83"	5000 LB. FLAT PAD
TRLR-300XF	DCA-300	250 GAL	HYDRAULIC SURGE	18000LBS	238"	83"	5000 LB. FLAT PAD
TRLR-400XF	DCA-400	350 GAL	ELECTRIC	18000LBS	238"	83"	5000 LB. FLAT PAD
TRLR-600XF	DCA-600, 800	550 GAL	AIR	30000LBS	384"	96"	5000 LB. FLAT PAD
TRLR-800SX	DCA-600, 800	550 GAL	AIR	30000LBS	384"	96"	5000 LB. FLAT PAD

# DCA-150SSJU —TRAILER-SPECIFICATIONS

**Table 1. Specifications (Con't)**

MODEL	COUPLER	TIRES	WHEELS	AXLE	HUBS	SUSPENSION	ELECTRICAL
TRLR-10-15W	2" BALL CLASS 2 ADJUSTABLE	175-13C	13"X4.50"	2200# 2X2	5 LUG	3 LEAF	4 WIRE LOOM W/ 4 POLE FLAT
TRLR-10X	2" BALL CLASS 2 ADJUSTABLE	175-13C	13"X4.5"	2200#2X2	5 LUG	3 LEAF	4 POLE FLAT
TRLR-10XF	2" BALL CLASS 2 ADJUSTABLE	175-13C	13"X4.5"	2200#2X2	5 LUG	3 LEAF	4 POLE FLAT
TRLR-225W	2" BALL CLASS 2 ADJUSTABLE	175-13B	13X4.5"	2200#2X2	5 LUG	Q FLEX	4 POLE FLAT
BLW 400	2" BALL CLASS 2 ADJUSTABLE	175-13C	13 X 4.5"	2200#2X2	5 LUG	3 LEAF	4 POLE FLAT
TRLR-15XF	2" BALL CLASS	B78-13LRC	13"X4.50"	3500# 2-1/2"	5 LUG	4 LEAF	4 POLE RUBBER FLAT
TRLR-50X	2" BALL CLASS	B78-13LRC	13"X4.50"	3500lbs. 2-3/8"	5 LUG	4 LEAF	4 POLE RUBBER FLAT
TRLR-50XF	2" BALL CLASS	B78-13LRC	13"X4.50"	3500lbs. 2-3/8"	5 LUG	4 LEAF	4 POLE RUBBER FLAT
TRLR-70W	2" BALL CLASS 3" ADJUSTABLE	205-14C BIAS (4)	14"X5"	3500lbs. 3"	5 LUG	5 LEAF	4 POLE RUBBER FLAT
TRLR-70X	2" BALL CLASS 3" ADJUSTABLE	205-14C BIAS (4)	14"X5"	3500lbs 3"	5 LUG	5 LEAF	4 POLE RUBBER FLAT
TRLR-70XF	2" BALL CLASS 3" ADJUSTABLE	205-14C BIAS (4)	14"X5"	3500lbs. 3"	5 LUG	5 LEAF	4 POLE RUBBER FLAT
TRLR-100XF	ADJUSTABLE 2-5/6 OPT 3" EYE	205-15C BIAS (4)	14"X5.5"	3500lbs 3"	5 LUG	5 LEAF	4 WIRE LOOM
TRLR-85/125	ADJUSTABLE 2-5/6 OPT 3" EYE	ST225/75R15D RADIAL (4)	14"x6"	(2)-6000lbs	6 LUG	7 LEAF	4 WIRE LOOM
TRLR-150XF	3" BALL EYE	750-16 E BIAS (4)	16"X7"	(2)-6000lbs	8 LUG	7 LEAF	4 WIRE LOOM
TRLR-220XF	3" EYE ADJUSTABLE	ST235/85R16E RADIAL(4)	16"X7"	(2)-7000lbs	8 LUG	Q FLEX	4 WIRE LOOM
TRLR-300XF	3" EYE ADJUSTABLE	ST235/85R16E RADIAL(6)	16"X7"	(2)-6000lbs	8 LUG	Q FLEX	4 WIRE LOOM
TRLR-400XF	3" EYE ADJUSTABLE	ST235/85R16E RADIAL(6)	16"X7"	(3)-7000lbs.	8 LUG	Q FLEX	4 WIRE LOOM
TRLR-600XF	5TH WHEEL	ST215/75R17.5H RADIAL (8)	16"X7"	(3)-10000lbs	8 LUG	7 LEAF	6 WIRE LOOM
TRLR-800AR	5TH WHEEL	ST215/75R17.5H RADIAL (8)	16"X7"	(3)-10000lbs	8 LUG	AIR-RIDE	6 WIRE LOOM

## Brakes

If your trailer has a braking system, the brakes should be inspected the first 200 miles of operation. This will allow the brake shoes and drums to seat properly. After the first 200 mile interval, inspect the brakes every 3,000 miles. If driving over rough terrain, inspect the brakes more frequently.

## Electric Brakes

Electrically actuated brakes (Figure 2) are similar to hydraulic brakes. The basic difference is that hydraulic brakes are actuated by an electromagnet.

Listed below are some of the advantages that electric brakes have over hydraulic brakes:

- An electric brake system can be manually adjusted to provide the corrected braking capability for varying road and load conditions.
- An electric brake system can be modulated to provide more or less braking force, thus easing the brake load on the towing vehicle.
- An electric brake system has very little lag time between the time the vehicle's brakes are actuated and the trailer's brakes are actuated.
- An electric brake system can provide an independent emergency brake system.

Road testing is necessary in order to properly synchronize the towing vehicle's braking to the trailer's braking. Brake lockup, grabbiness, or harshness is due to lack of

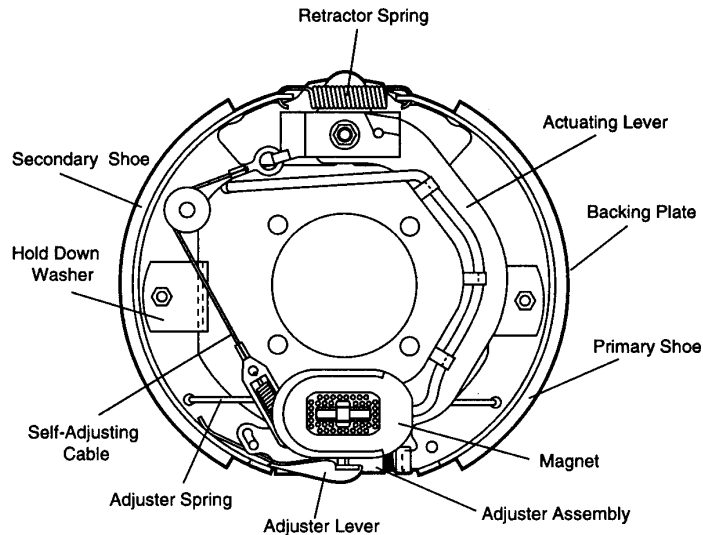
synchronization between the tow vehicle and the trailer being towed or under-adjusted brakes.

Before any brake synchronizations adjustments can be made, the trailer brakes should be burnished-in by applying the brakes 20-30 times with approximately a 20 m.p.h. decrease in speed, e.g. 40 m.p.h. to 20 m.p.h.. Allow ample time for brakes to cool between application. This allows the brake shoes to slightly be seated into the brake drum surface.

Figure 2 displays the major electric brake components that will require inspection and maintenance. Please inspect these components as required. Refer to Table 5 for electric brake troubleshooting guidelines.

## Electric Brake Adjustment

1. Place the trailer on jack stands. Make sure the jack stands are placed on secure level ground.
2. Check the wheel and drum for free rotation.
3. Remove the adjusting hole cover from the adjusting slot at the bottom brake backing plate.
4. With a screwdriver or standard adjusting tool, rotate the star wheel of the adjuster assembly to expand the brake shoes.
5. Adjust the brake shoes outward until the pressure of the lining against the wheel drum makes the wheel difficult to turn.
6. Rotate the star wheel in the opposite direction until the wheel rotates freely with slight lining drag.
7. Replace the adjusting hole cover and lower the trailer to the ground.
8. Repeat steps 1 through 6 on the remaining brakes.

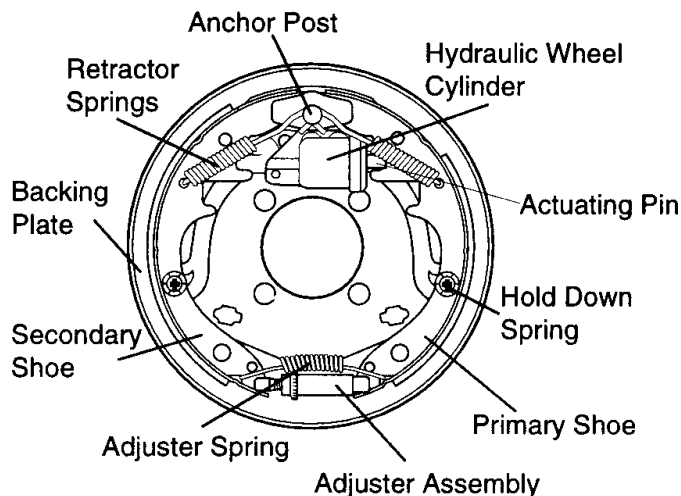


**Figure 2. Electrical Brake Components**

### Hydraulic/Air/Surge Brakes

Hydraulic brakes (Figure 3) should not require any special attention with the exception of routine maintenance such as shoe and lining replacement. These brakes can be adjusted in the same manner as electric brakes. Brake lines should be periodically checked for cracks, kinks, or blockage.

Figure 3 below displays the major hydraulic/air/surge brake components that will require inspection and maintenance. Inspect these components as required using steps 1 through 6 as referenced in the electric brake adjustments section. Reference Table 6 for hydraulic brake troubleshooting guidelines.



**Figure 3. Hydraulic Brake Components**

## Tires/Wheels/Lug Nuts

Tires and wheels are a very important and critical components of the trailer. When specifying or replacing the trailer wheels it is important the wheels, tires, and axle are properly matched.

## CAUTION:



DO NOT attempt to repair or modify a wheel. DO NOT install an inner tube to correct a leak through the rim. If the rim is cracked, the air pressure in the inner tube may cause pieces of the rim

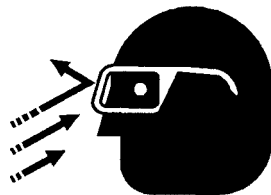
to explode (break off) with great force and cause serious eye or bodily injury.

## Tire Wear/Inflation

Tire inflation pressure is the most important factor in preserving tire life. Pressure should be checked cold before operation. **DO NOT** bleed air from tires when they are hot. Check inflation pressure weekly to insure the maximum tire life and to prevent premature tread wear.

Table 2 (Tire Wear Troubleshooting) will help pinpoint the causes and solutions of tire wear problems.

## CAUTION:



### NOTE

ALWAYS wear safety glasses when removing or installing force fitted parts. Failure to comply may result in serious injury.

TABLE 2. TIRE WEAR TROUBLESHOOTING

WEAR PATTERN	CAUSE	SOLUTION
Center Wear	Over Inflation.	Adjust pressure to particular load per tire manufacturer.
Edge Wear	Under Inflation.	Adjust pressure to particular load per tire manufacturer.
Side Wear	Loss of chamber or overloading.	Make sure load does not exceed axle rating. Align wheels.
Toe Wear	Incorrect toe-in.	Align wheels.
Cupping	Out-of-balance.	Check bearing adjustment and balance tires.
Flat Spots	Wheel lockup & tire skidding.	Avoid sudden stops when possible and adjust brakes.

## Suspension

The leaf suspension springs and associated components (Figure 4) should be visually inspected every 6,000 miles for signs of excessive wear, elongation of bolt holes, and loosening of fasteners. Replace all damaged parts (suspension) immediately. Torqued suspension components as detailed in Table 3.

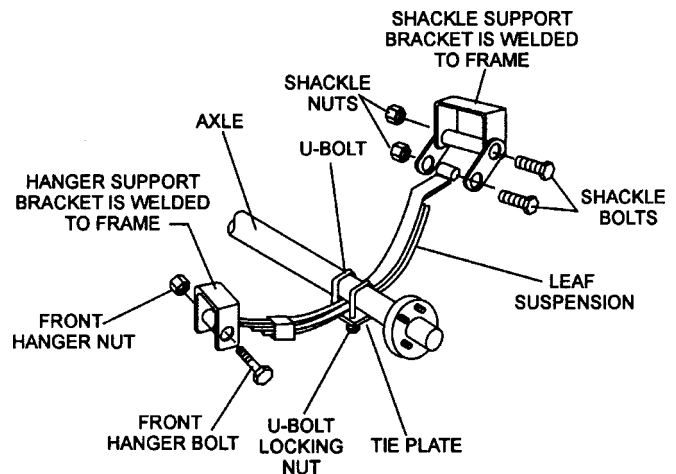


Figure 4. Suspension Components

# DCA-150SSJU — TRAILER TIRES & SUSPENSION

**Table 3. Suspension Torque Requirements**

Item	Torque (Ft.-Lbs.)
3/8" U-BOLT	MIN-30 MAX-35
7/16" U-BOLT	MIN-45 MAX-60
1/2" U-BOLT	MIN-45 MAX-60
SHACKLE BOLT SPRING EYE BOLT	SNUG FIT ONLY. PARTS MUST ROTATE FREELY. LOCKING NUTS OR COTTER PINS ARE PROVIDED TO RETAIN NUT-BOLT ASSEMBLY.
SHOULDER TYPE SHACKLE BOLT	MIN-30 MAX-50

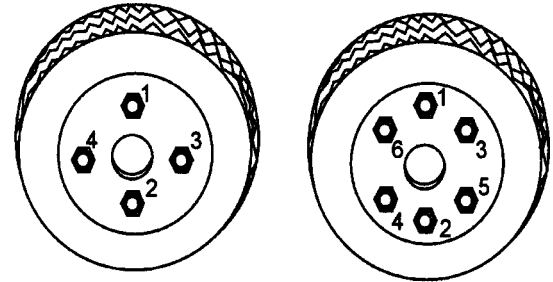
## Lug Nut Torque Requirements

It is extremely important to apply and maintain proper wheel mounting torque on the trailer. Be sure to use only the fasteners matched to the cone angle of the wheel. Proper procedure for attachment of the wheels is as follows:

1. Start all wheel lug nuts by hand.
2. Torque all lug nuts in sequence. See Figure 5. **DO NOT** torque the wheel lug nuts all the way down. Tighten each lug nut in 3 separate passes as defined by Table 4.
3. After first road use, retorque all lug nuts in sequence. Check all wheel lug nuts periodically for continued safe operation.

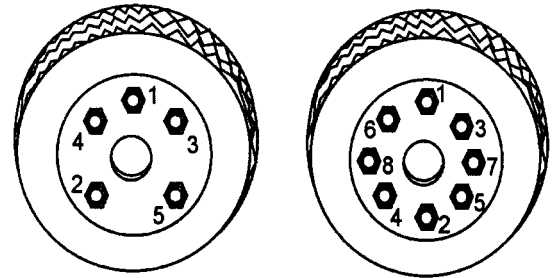
**Table 4. Tire Torque Requirements**

Wheel Size	First Pass FT-LBS	Second Pass FT-LBS	Third Pass FT-LBS
12"	20-25	35-40	50-65
13"	20-25	35-40	50-65
14"	20-25	50-60	90-120
15"	20-25	50-60	90-120
16"	20-25	50-60	90-120



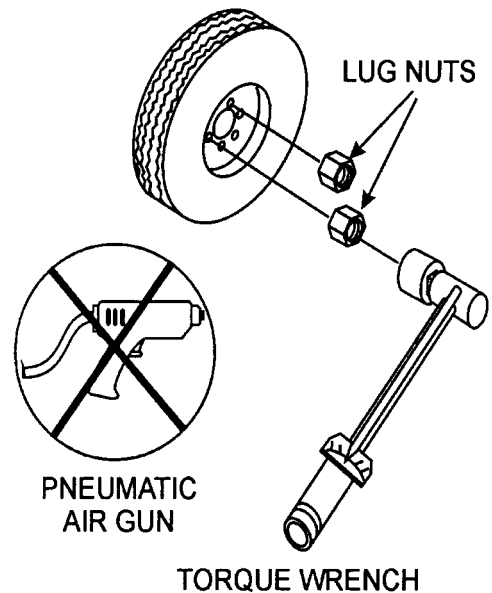
4-LUG NUTS

6-LUG NUTS



5-LUG NUTS

8-LUG NUTS



**Figure 5. Lug Nut Tightening Sequence**

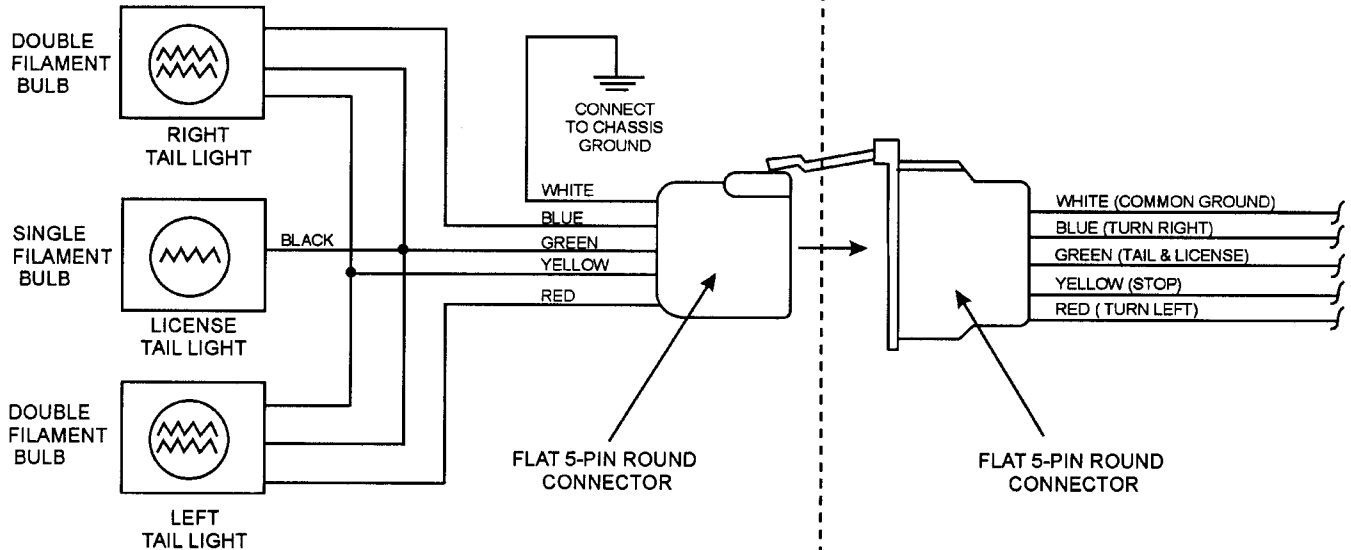
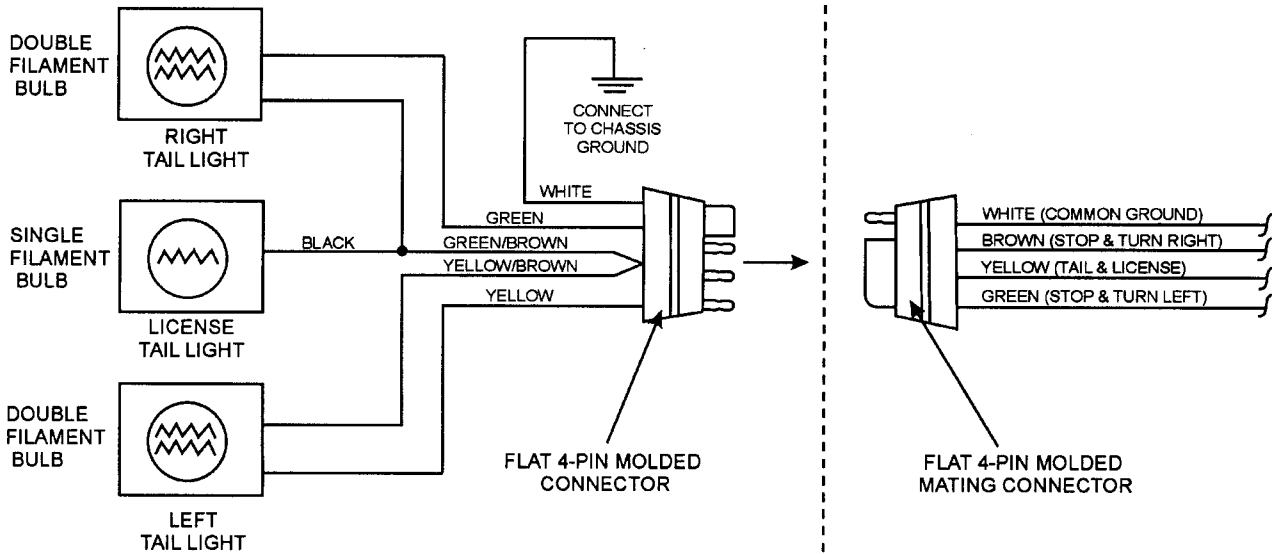
**NOTE**

NEVER use an pneumatic air gun to tighten wheel lug nuts.

# DCA-150SSJU — TRAILER WIRING DIAGRAMS

## TRAILER SIDE

## TOWING VEHICLE SIDE



**NOTE:**  
LIGHTS ARE ORIENTED FROM THE DRIVER'S SEAT

**Table 5. Electric Brake Troubleshooting**

Symptom	Possible Cause	Solution
No Brakes or Intermittent Brakes	Any open circuits or broken wires?	Find and correct.
	Any short circuits?	Find and correct.
	Faulty controller?	Test and correct.
	Any loose connections?	Find and repair.
	Ground wire secure?	Find and secure.
Weak Brakes or Brakes Pull to One Side	Grease or oil on magnets or linings?	Clean or replace.
	Connections corroded?	Clean and correct cause of corrosion.
	Brake drums scored or grooved?	Machine or replace.
	Brakes synchronized?	Correct.
Locking Brakes	Brake components loose, bent or broken?	Replace components.
	Brake drums out-of-round?	Replace.
Noisy Brakes	System lubricated?	Lubricate.
	Brake components correct?	Replace and correct.
Dragging Brakes	Bearings of the wheel adjusted?	Adjust.

**Table 6. Hydraulic Brake Troubleshooting**

Symptom	Possible Cause	Solution
No Brakes	Brake line broken or kinked?	Repair or replace.
Weak Brakes or Brakes Pull to One Side	Brake lining glazed?	Reburnish or replace.
	Trailer overloaded?	Correct weight.
	Brake drums scored or grooved?	Machine or replace.
	Tire pressure correct?	Inflate all tires equally.
	Tires unmatched on the same axle?	Match tires.
Locking Brakes	Brake components loose, bent or broken?	Replace components.
	Brake drums out-of-round?	Replace.
Noisy Brakes	System lubricated?	Lubricate.
	Brake components correct?	Replace and correct.
Dragging Brakes	Brake lining thickness correct or in right wrong position?	Install new shoes and linings.
	Enough brake fluid or correct fluid?	Replace rubber parts fill with dot4 fluid.

# DCA-150SSJU — GENERATOR DECALS

The DCA-150SSJU generator is equipped with a number of safety decals. These decals are provided for operator safety and maintenance information. The illustration below and on the preceding pages show the decals as they appear on the machine. Should any of these decals become unreadable, replacements can be obtained from your dealer.

**OPERATING PROCEDURES**

**Manual Starting**

1. Check the engine oil, coolant, and fuel levels. Replenish if necessary.
2. Place all Generator Circuit Breakers in the "OFF" position and close all doors.
3. Check that the Voltage select switch (or the Voltage change-over board) is present at desired voltage.  
(In case of generator having multiple voltage ratings.)
4. Set the Engine speed switch to the "LOW" position.
5. Turn the Auto-Off/Reset-Manual switch to the "Manual" position to start the engine. If the engine fails to start in the specified number of attempts, the overcrank lamp will indicate and the Auto-Off/Reset-Manual switch must be returned to the "Off/Reset" position before proceeding.
6. When the engine is ready for starting during cold weather operating conditions, push the intake heater button for approximately 30 seconds. Start engine using the Auto-Off/Reset-Manual switch to the "Manual" position. As soon as the engine starts, release the button.
7. If the engine still does not start, utilize the water heater until water is warm. (If additional water heater is supplied.)
8. After starting, allow the engine to run for 1 or 2 minutes to warm up. At temperatures below freezing, this time period must be extended to 2 to 4 minutes.
9. When the engine starts, immediately check for abnormal noise, vibration, fluid leakage or any indication of a problem. Check the control panel gauges. If all is normal, let the engine remain at the "Low" position for a short time, depending on the ambient conditions, warm up.
10. After sufficient warm-up time has elapsed, set the Engine speed switch to the "High" position and the table to ready for operation.
11. Check the NO-Load speed as shown in the table below.  
60Hz operation—Approx. 60 Ohz (1500rpm)
12. Adjust the Voltage Regulator to the specified voltage.

**Manual Stopping**

1. Place the Generator Circuit Breakers in the "OFF" position.
2. Set the Engine speed switch to the "LOW" position, and allow the unit to cool for a few minutes.
3. Turn the Auto-Off/Reset-Manual switch, to the "Off/Reset" position.

**Auto Starting/Stopping**

1. With the Auto/Manual switch in the Auto position, the Auto Starting/Stopping controller monitors remote start contacts. Closure of the remote start contacts will begin engine cranking. When the contacts are opened cranking will stop or if running the engine will stop. All functions of the Automatic shutdown System work as in Manual Starting/Stopping.
2. For cold weather conditions utilize the water heater until water is warm. If the engine still does not start, please operate as in Manual Starting.

**Emergency Stopping**

1. Place the Generator Circuit Breakers in the "OFF" position.
2. Turn the Auto-Off/Reset-Manual switch to the "Off/Reset" position.

M35200010

P/N M3552000103

**SAFETY INSTRUCTIONS**

Improper operation of this machine can cause severe injury or death.

- Read the instruction manual carefully before operating or servicing.

This machine should only be operated by a person with sufficient knowledge and skill to ensure safe operation.

High voltage circuits are located inside the output terminal cover and control panel

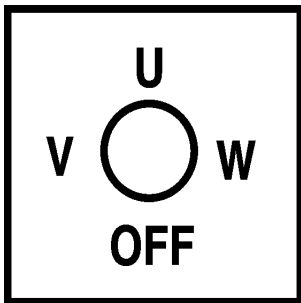
- Close the cover and control panel before operating.

Moving parts and hot surfaces are contained within the enclosure.

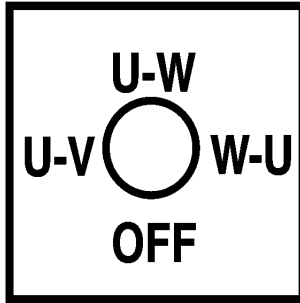
- Close all doors and lock them before operating.

M92010030

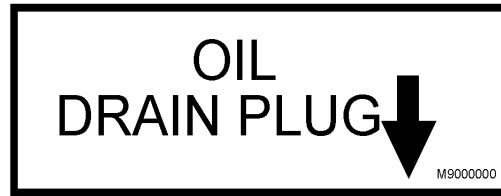
P/N M9520100304



P/N M9520000104



P/N M9520000204



P/N M950000004

**OVER CURRENT RELAY**

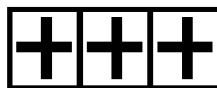
If it is Impossible to reset the CIRCUIT BREAKER, open the control panel and push the RESET BUTTON as below.

M92020010

P/N M9520200104



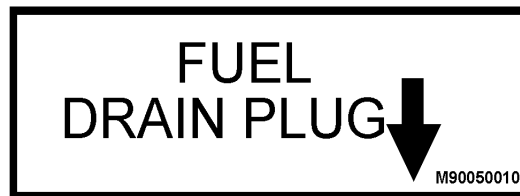
P/N M9510200002



P/N M9500300104



P/N M9500300004




P/N M9500500104



P/N M9500500004



P/N M9503000103



**⚠ WARNING**  
**ELECTRIC SHOCK HAZARD**

- Do not touch internal wiring or connections while this machine is operating.
- Turn power off before servicing.

M92010000

P/N M9520100004

**DANGER**

**HIGH VOLTAGE**

M92010040


P/N M9520100401


**NOTE**

To use 50 AMP receptacles, adjust the voltage selector switch to the single phase position and the main line circuit breaker to the on position.

M1500020

P/N M1550000204

	<p><b>⚠ WARNING</b>  <b>ELECTRIC SHOCK HAZARD</b></p> <ul style="list-style-type: none"> <li>• Do not touch output terminals while this machine is operating.</li> <li>• Turn power off before servicing.</li> </ul>	<p><b>⚠ WARNING</b>  <b>ELECTRIC SHOCK HAZARD</b></p> <ul style="list-style-type: none"> <li>• Always complete the grounding path from the ground terminal on this genset to an external grounding source. See instruction manual for details.</li> </ul>	<p><b>⚠ WARNING</b></p> <ul style="list-style-type: none"> <li>• Before connecting this generator to any building's electrical system, a licensed electrician must install an isolation (transfer) switch.</li> <li>• Serious injury or death may result without this transfer switch.</li> </ul>
	M92010050		
	P/N M9520100503		



**⚠ WARNING**  
**HOT COOLANT can cause severe burns.**

- Do not remove cap if radiator is hot.

M90310000

P/N M9503100004



**⚠ WARNING**  
**ENGINE EXHAUST can cause severe injury or death.**

- Use only in open, well ventilated areas or vent exhaust outside.


M90320000

P/N M9503200004

**⚠ CAUTION**  
**Stop engine before switching.**

M92010020

P/N M9520100204




**⚠ CAUTION**  
**MOVING PARTS can cause severe injury.**

- Do not operate with doors open.
- Stop engine before servicing.

M90300000

P/N M9503000004




**⚠ WARNING**  
**HOT PARTS can burn skin.**

- Do not touch until the machine has sufficiently cooled.

M91010000

P/N M9510100004



**⚠ WARNING**  
**ELECTRIC SHOCK HAZARD**

- Do not touch internal wiring or connections while this machine is operating.
- Turn power off before servicing.

M92010000

P/N M9520100004

# DCA-150SSJU — SPECIFICATIONS

Table 7. Specifications		
Generator Specifications		
Model	DCA-150SSJU	
Type	Revolving field, self ventilated, open protected type synchronous generator	
Armature Connection	<b>Star with Neutral</b>	<b>Zig Zag</b>
Phase	3	Single
Standby Output	165 KVA (132 KW)	96KW
Prime Output	150 KVA (120 KW)	87KW
Voltage	240V or 480V	240/120V
Frequency	60 Hz	
Speed	1800 rpm	
Power Factor	0.8	1
Aux. AC Power	Single Phase, 60 Hz	
Voltage	120 V	
Output	4.8 KW (2.4 KW x 2)	
Engine Specifications		
Model	JOHN DEERE 6081 TF 001	
Type	4-cycle, water-cooled, direct injection, turbo-charged	
No. of Cylinders	6 cylinders	
Bore x Stroke	4.57 in. x 5.08 in. (116 mm x 129 mm)	
Rated Output	190HP/1800 rpm	
Displacement	494 cu. in. (8100 cc)	
Starting	Electric	
Coolant Capacity	10.9 gal. (41 liters)	
Lube Oil Capacity	8.5 gal. (32 liters)	
Fuel Consumption	9.7 gal. (36.7L)/hr at <b>full load</b>	7.5 gal. (28.3L)/hr at <b>3/4 load</b>
	5.3 gal. (20L)/hr at <b>1/2 load</b>	3.5 gal. (13.2L)/hr at <b>1/4 load</b>
Battery	12V- 225AHx1	
Fuel	#2 Diesel Fuel	

## DCA-150SSJU FAMILIARIZATION

### Generator

The MQ Power Model DCA-150SSJU is a 120 kW *generator* that is designed as a high quality portable (requires a trailer for transport) power source for telecom sites, lighting facilities, power tools, submersible pumps and other industrial and construction machinery.

### Engine Control Panel

The "Engine Control Panel" is provided with the following:

- Tachometer
- Water Temperature Gauge
- Oil Pressure Gauge
- Charging Ammeter Gauge
- Engine Speed Switch
- Microprocessor Engine Controller (if applicable)
- Pre-Heat Button
- Pre-Heat Lamp
- Key Ignition starter
- Fuel Gauge
- Panel Light
- Panel Light Switch

### Generator Control Panel

The "Generator Control Panel" is provided with the following:

- Output Voltage Adjustment Knob
- Frequency Meter (Hz)
- AC Ammeter (Amps)
- AC Voltmeter (Volts)
- Ammeter Change-Over Switch
- Voltmeter Change-Over Switch

### Output Terminal Panel

The "Output Terminal Panel" is provided with the following:

- Three 240/139V output receptacles, 50 amp
- Two 120V input receptacles, 20 amp
- 3 Load Circuit Breakers 265V @65 amps
- 2 Load GFCI Circuit Breakers 265V@ 20amps

### Control Box

The "Control Box" is provided with the following:

- Main Circuit Breaker 400 amps
- Over-Current Relay

### Open Delta Excitation System

The DCA-150SSJU generator is equipped with the state of the art "*Open-Delta*" excitation system. The open delta system consist of an electrically independent winding wound among stationary windings of the AC output section.

There are four leads: A, B, C and D. During light loads, the power to the *Automatic Voltage Regulator* (AVR) is supplied from the leads parallel connections of B&C. When loads increase, the AVR switches and accepts power from leads A&D. The output of leads A&D increase proportionally with load. This of adding the voltages to each phase provides better voltage response during heavy loads.

The connections of the AVR to the AC output windings are for sensing only. No power is required from these windings.

The open-delta design provides virtually unlimited excitation current, offering maximum motor starting capabilities. The excitation does not have a "*fixed ceiling*" and responds according the demands of the required load.

### Engine

The **DCA-150SSJU** is powered by a 4 cycle, water cooled, turbocharged John Deere 6081TF001 diesel engine. This engine is designed to meet every performance requirement for the generator. Reference Table 7, page 23 for engine specifications.

In keeping with Multiquip's policy of constantly improving its products, the specifications quoted herein are subject to change without prior notice.

The basic controls and indicators for the DCA-150SSJU generator are addressed on the following pages.

### Mechanical Governor System

The mechanical governor system control the RPM of the engine. When the engine demands increase or decrease, the mechanical governor system regulates the frequency variation to  $\pm 1.5\%$ . The electronic governor option increases frequency variation to  $\pm 0.25\%$ .



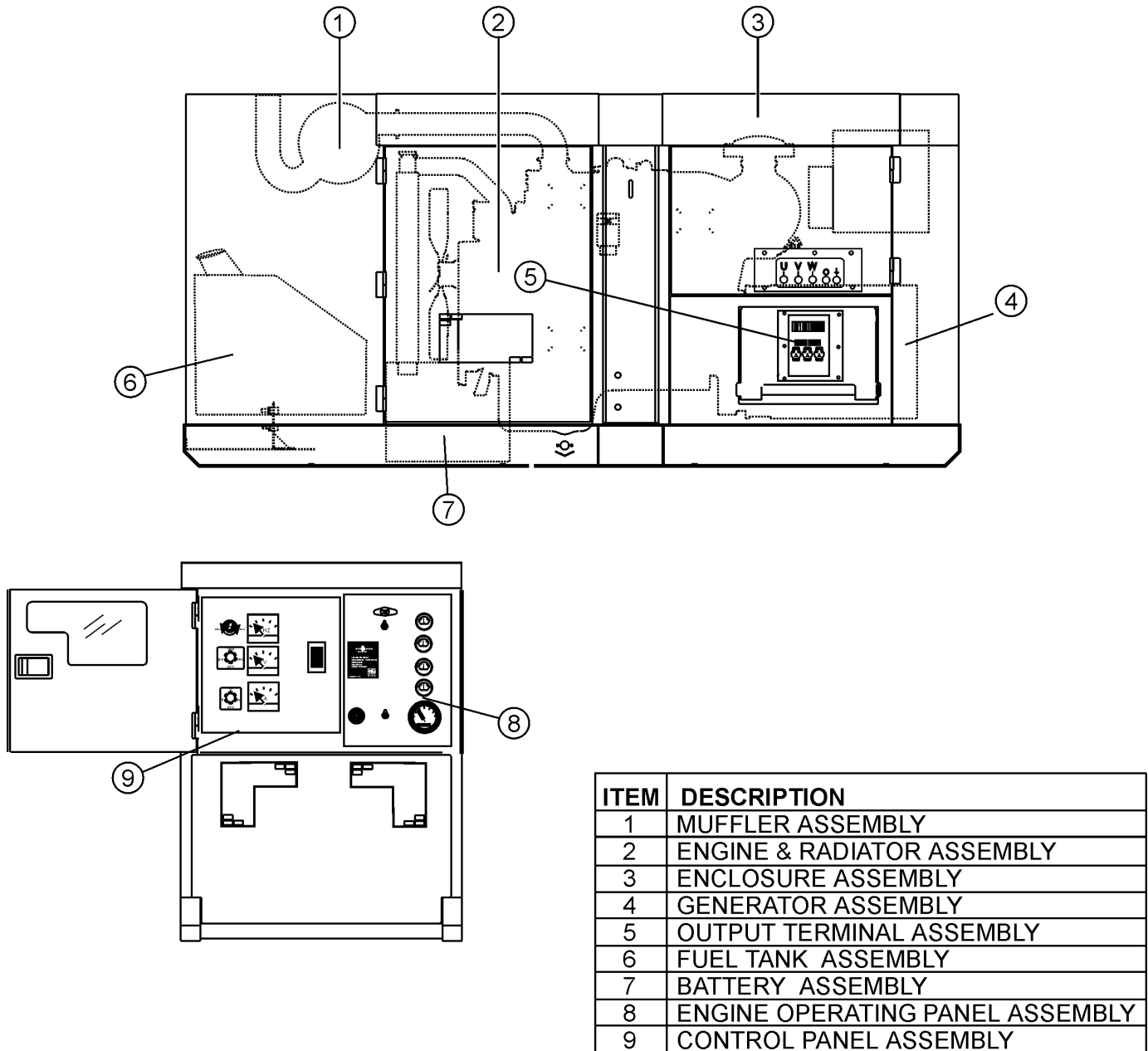
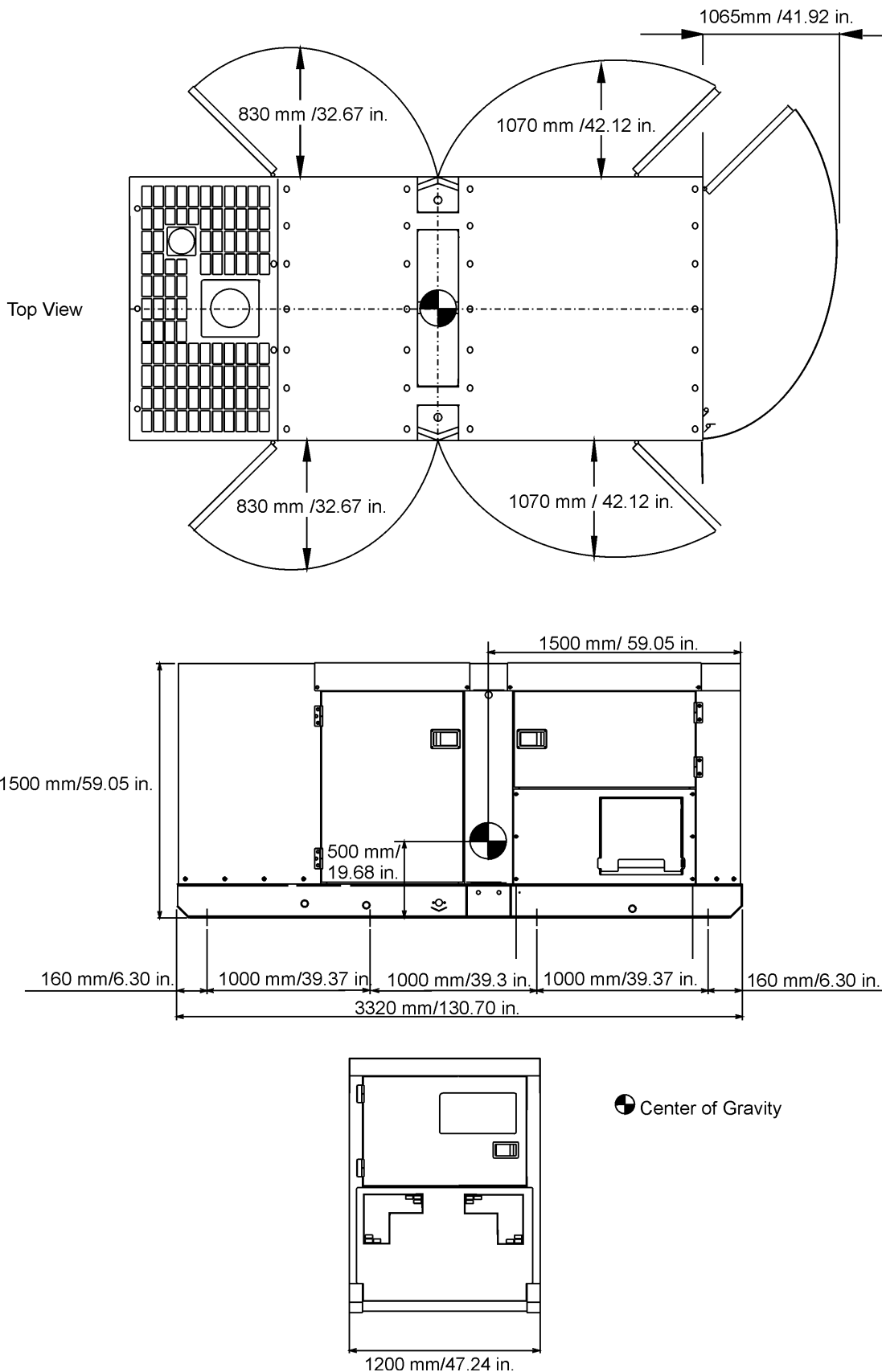
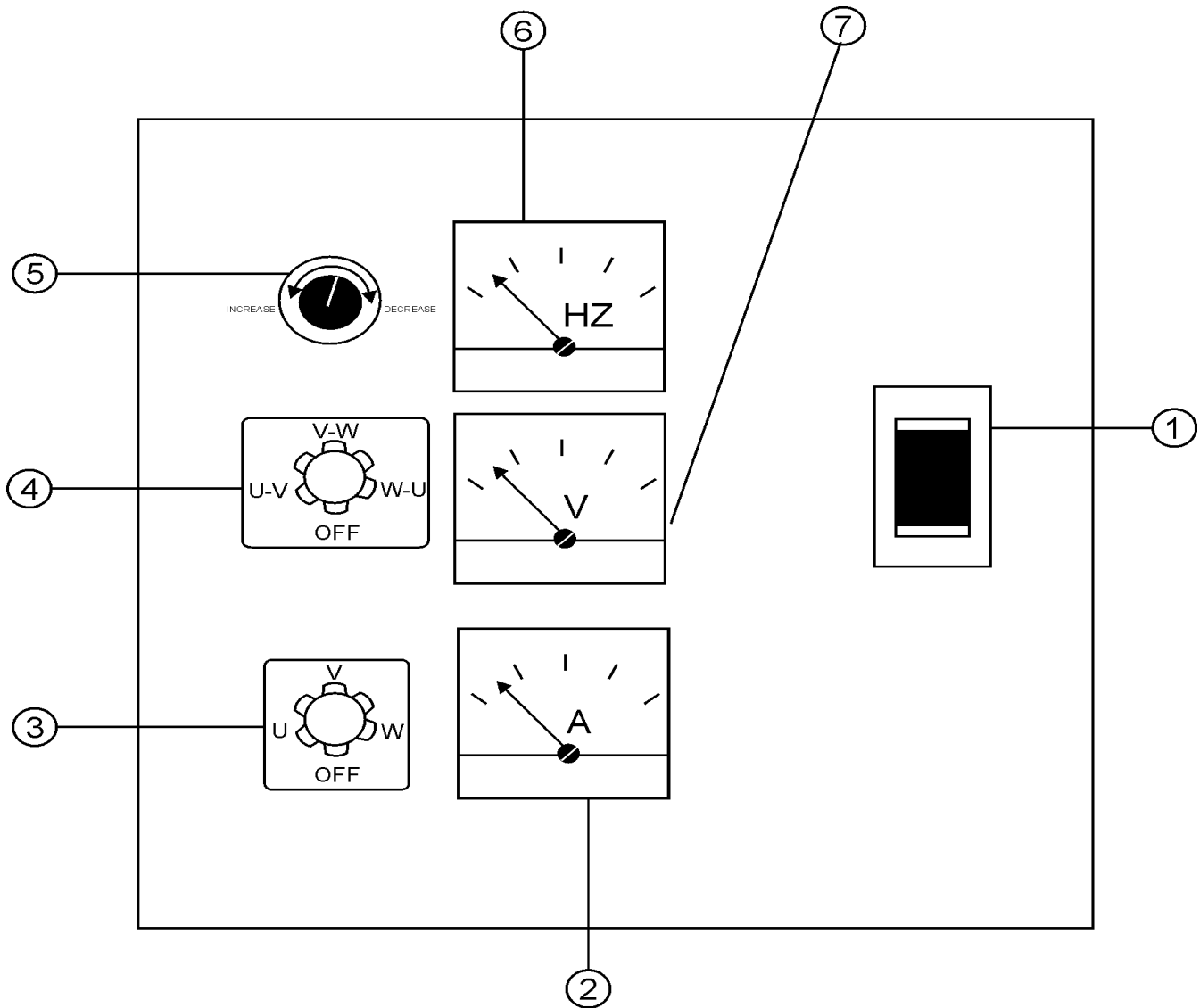


Figure 4. Major Components

# DCA-150SSJU — DIMENSIONS



**Figure 5. Dimensions**



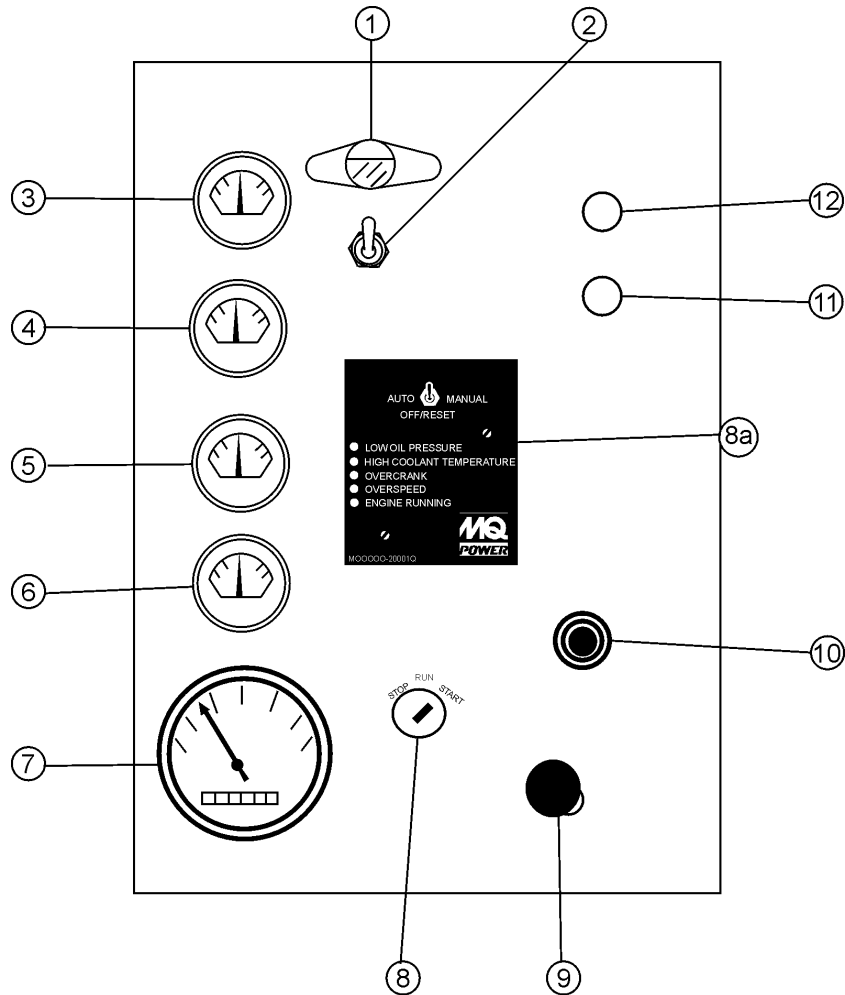
NO	DESCRIPTION
1	CIRCUIT BREAKER
2	AC AMMETER
3	AMMETER CHANGE-OVER SWITCH
4	VOLTMETER CHANGE-OVER SWITCH
5	VOLTAGE REGULATOR
6	FREQUENCY METER
7	AC VOLTMETER

Figure 6. Control Panel

The definitions below describe the controls and functions of the DCA-150SSJU " **Control Panel** " (Figure 6).

1. **Pilot Lamp** – Indicates that the generator is working properly.
2. **Panel Light** – Normally used in dark areas or at night time. When activated, panel lights will illuminate. When the generator is not in use be sure to turn the panel light switch to the OFF position.
3. **Frequency Meter** – Indicates the output frequency in hertz (Hz). Normally 60 Hz  $\pm$ 1 Hz .
4. **AC Ammeter** – Indicates the amount of current the load is drawing from the generator.
5. **AC Voltmeter** – Indicates the single phase output voltage present at the UNV terminals.
6. **Ammeter Change-Over Switch** – This switch allows the AC ammeter to indicate the current flowing to the load connected to any phase of the output terminals, or to be switched off.
7. **Voltmeter Change-Over Switch** – This switch allows the AC voltmeter to indicate phase to phase voltage between any two phases of the output terminals or to be switched off.
8. **Panel Light Switch** – When activated will turn on control panel light.
9. **Voltage Regulator Control** – Allows manual adjustment of the generator's output voltage
10. **Main Circuit Breaker** – This three-pole, 800 amp main breaker is provided to protect the UNV voltage output terminals from overload.

# DCA-150SSJU — ENGINE OPERATING PANEL



NO	DESCRIPTION
1	PANEL LIGHT
2	PANEL LIGHT SWITCH
3	OIL PRESSURE GAUGE
4	WATER TEMPERATURE GAUGE
5	CHARGING AMMETER
6	FUEL GAUGE
7	TACHOMETER
8	IGNITION SWITCH
8a	MICROPROCESSOR ENGINE CONTROLLER (MPEC) (IF APPLICABLE)
9	ENGINE SPEED LEVER
10	PREHEAT BUTTON
11	WATER TEMPERATURE INDICATOR

Figure 7. Engine Operating Panel

## DCA-150SSJU — ENGINE OPERATING PANEL

The definitions below describe the controls and functions of the DCA-150SSJU " **Engine Operating Panel** " (Figure 6).

1. **Panel light** - Normally used in dark places or at night. When activated, panel will luminate. When the generator is not in use, turn the panel light switch to the 'OFF' position.
2. **Panel light switch**- When activated, will turn on control panel light.
3. **Oil Pressure Gauge** – During normal operation this gauge be should read in the "GREEN" zone. When starting the generator the oil pressure mar read a little bit higher, but after the engine warms up the oil pressure should return to the green zone.
4. **Water Temperature Gauge** – During normal operation this gauge be should read in the "GREEN" zone.
5. **Charging Ammeter Gauge** – Indicates the current being supplied by the engine's alternator which provides current for generator's control circuits and battery charging system.
6. **Fuel Gauge** - Indicates amount of diesel fuel available.
7. **Tachometer** – Indicates engine speed in RPM's for 60 Hz operation. This meter should indicate 1800 RPM's when the rated load is applied. In addition a built in hour meter will record the number of operational hours that the generator has been in use.
8. **Ignition Switch** - This switch is used to turn on or off the engine with a key.
- 8a. **MPEC – Microprocessor Engine Control Module** – (MPEC) has a vertical row of status LED's (Figure 5), that when lit, indicate that a engine malfunction (fault), has been detected. When a fault has been detected the MPEC will evaluate the fault and all major faults will shutdown the generator.
- A. **Off/Manual/Auto Switch** – This switch controls the running of the generator. If this switch is left in the "OFF" position, the generator will not run. When this switch is set to the **manual** position, the generator will start immediately.
- B. **Low Oil Pressure** – Indicates the engine pressure has fallen below 15 psi. The oil pressure is detected using variable resistive values from the oil pressure sending unit. This is considered a **major** fault.
- C. **High Coolant Temperature** – Indicates the engine temperature has exceeded 215°F. The engine temperature is detected using variable resistive values from the temperature sending unit. This is considered a **major** fault.
- D. **Overcrank Shutdown** – Indicates the unit has attempted to be started a pre- programmed number of times, and has failed to start. The number of cycles and duration are programmable. It is pre-set at 3 cycles with a 10 second duration. This is considered a **major** fault.
- E. **Overspeed Shutdown** – Indicates that the engine is running at an unsafe speed. This is considered a **major** fault.
- F. **Engine Running** – Indicates that engine is running at a safe operating speed.
9. **Throttle Handle** - This handle controls the speed of the engine (low or high).
10. **Pre-Heat Button** – Press hold this button until the preheat lamp is lit (ON).
11. **Water Temperature Indicator** - This light indicates the water temperature is too high and will shut down the engine.
12. **Oil Pressure Indicator** - This light indicates the oil pressure is either too high or too low and will shut down the engine.

If the generator is to be connected to a building's AC power source via a transfer switch (isolation), place the switch in the **auto** position. In this position the generator will monitor the AC line output from the building's power source.

# DCA-150SSJU — OUTPUT TERMINAL PANEL OVERVIEW

## OUTPUT TERMINAL PANEL FAMILIARIZATION

The "Output Terminal Panel" is provided with the following:

- Three 240/139V output receptacles, 50 amp
- Two 120V input receptacles, 20 amp
- 3 Load Circuit Breakers 265V @65 amps
- 2 Load GFCI Circuit Breakers 265V @ 20amps

## Control Box

The "Control Box" is provided with the following:

- Main Circuit Breaker 400 amps
- Over-Current Relay

## Output Terminal Panel

The Output Control Panel (See Figure 11) is located on the right hand side (left from control panel) of the generator. The UNV lugs are protected by a face plate cover that can be secured in the close position by a pad lock. (See Figure 8).

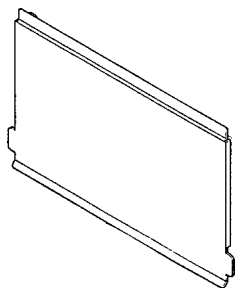


FIGURE 8. Output Terminal Cover

## 120 Volt Receptacle

Two GFCI Duplex Nema 5-20R (120V, 20 Amp) receptacle is provided on the output terminal. This receptacle can be used anytime the generator is in operation. The receptacle is controlled by the circuit breaker located on the control panel.

Pressing the reset button resets the receptacle after being tripped. Pressing the "Test Button" (See Figure 9) in the center of this receptacle will check the GFCI function. The receptacle should be tested at least once a month.

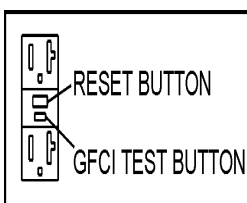


FIGURE 9. GFCI Test Button

## Connecting Load

Loads can be connected to the generator by the UNV Lugs or the convenience receptacles. (See figure 10). Make sure to read the operation manual before attempting to connect a load to the generator.

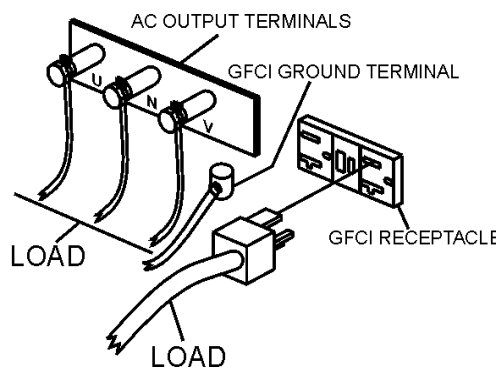


FIGURE 10. Connecting Load

## Circuit Breakers

To protect the generator from an overload, a 3-pole, 400 amp, **main** circuit breaker is provided to protect the UNV output terminals from overload. In addition two single-pole, 20 amp **GFCI** circuit breakers are provided to protect the GFCI receptacles from overload. Three 50 amp **load** circuit breakers have also been provided to protect the load side of the generator from overload. Make sure to switch **ALL** circuit breakers to the "OFF" position prior to starting the engine.

## Maximum Output

The entire load connected to the UNV Lugs, all four slots in the duplex receptacles, and the must not exceed 132 kW in standby or 120 kW in prime output.

**Twist Lock Dual Voltage Receptacles** - To use these receptacles, place the voltage selector switch in the single phase 240/120 voltage position and adjust the output voltage to 240 volts with the voltage regulator on the Control Panel. Place the voltmeter change-over switch to the U-W position and the ammeter change-over switch to the U or W to read the output.

# DCA-150SSJU — OUTPUT TERMINAL PANEL OVERVIEW

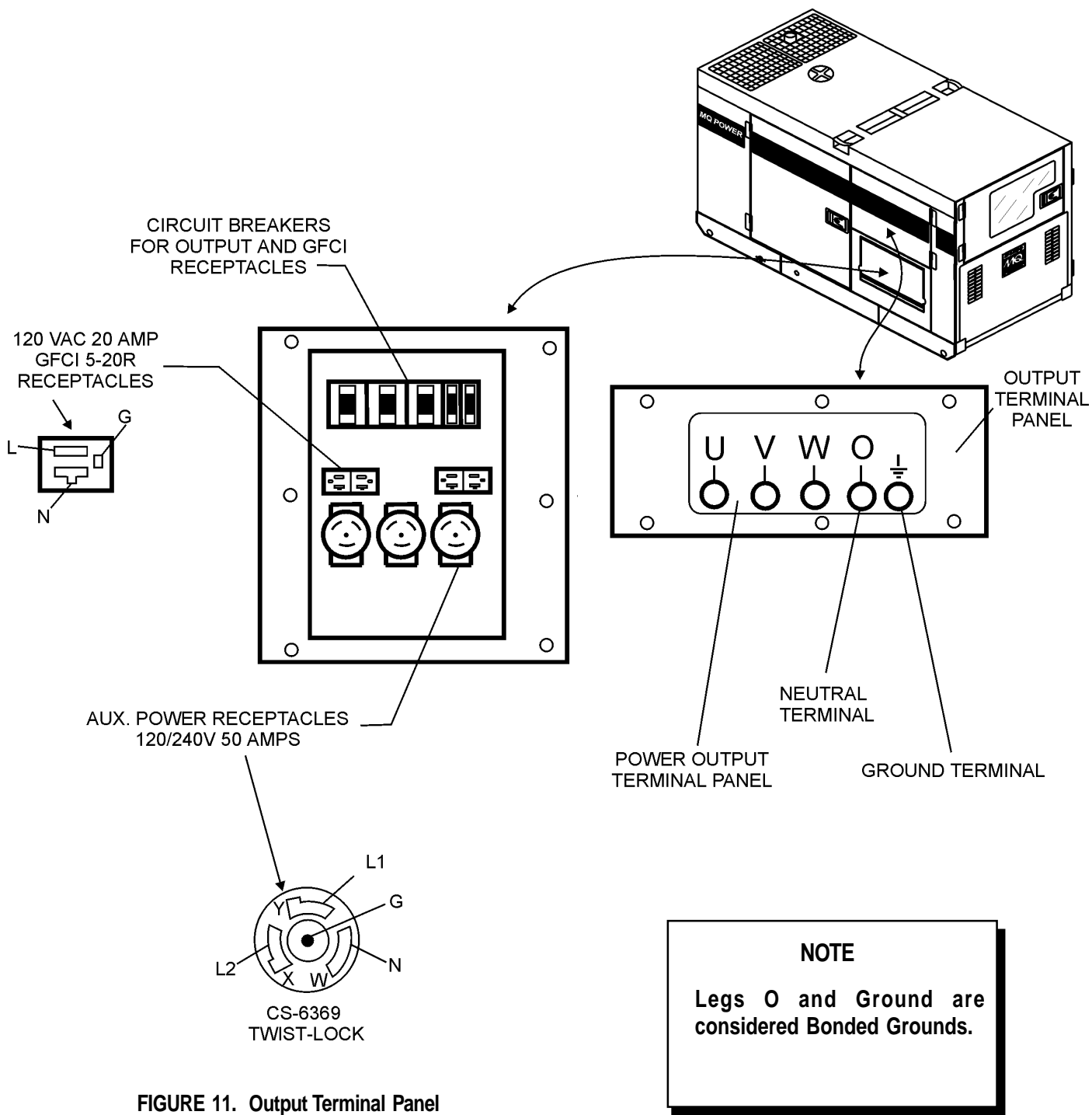


FIGURE 11. Output Terminal Panel

# DCA-150SSJU — OUTPUT TERMINAL PANEL OVERVIEW

## Output Terminal Panel Available Voltages

A wide range of voltages are available to supply load to many different applications. Voltages may be selected by using the voltage selector switch and how you hookup your hard wire connection to the generator. To obtain some of the voltages listed, fine adjustment with the Voltage Regulator on the control panel is necessary. See the table below (Table 8) for a list of available voltages the generator is able to supply.

TABLE 8. VOLTAGES AVAILABLE						
MODEL	DCA150SSJU					
3 PHASE VOLTAGE (SWITCHABLE)	208 VOLT	220 VOLT	240 VOLT	416 VOLT	440 VOLT	480 VOLT
SINGLE PHASE (SWITCHABLE)	120 VOLT	127 VOLT	139 VOLT	240 VOLT	254 VOLT	277 VOLT

## Voltage Selector Switch

The voltage selector switch is located above the UVWO Hard Wire Hookup Panel. It has been provided for ease of voltage selection.

## CAUTION :



**NEVER** switch Voltage Selector Switch position while the engine is engaged.

## Voltage Selector Switch Locking Button

The voltage selector switch has a locking button to protect the generator and generator load from being switched while the engine is running. To lock the Voltage Selector Switch, press in the red button located on the Voltage Selector Switch, and use a pad lock to hold it into this position.

## Over Current Relay

An over current relay is connected to the circuit breaker. In an over current situation, both the circuit breaker and the over current relay may trip. If the circuit breaker can not be reset, the reset button on the over current relay must be pressed. The over current relay is located in the control box.

## Maximum Amps

The following table show the maximum amps the entire generator can provide. Do not exceed the maximum amps listed. (See Table 9)

Table 9. Maximum Amps	
Model:	DCA150SSJU
Rated Voltage	Maximum Amps
Single Phase 120 Volt	333.3 amps (4 wire)
Single Phase 240 Volt	166.7 amps (4 wire)
Three Phase 240 Volt	361 amps
Three Phase 480 Volt	180 amps

## Receptacle Use

When the UVWO terminals are providing power, the receptacle power available decrease. Do not exceed receptacle power available listed on Table 10.

Table 10. Receptacle Use		
Power in Use		Receptacle Power Available
240/480V 3-Phase	240/120V Single Phase or Twist Lock CS6369	Duplex NEMA 5-20R 120V
KVA	KW	KW
150	87	0
146	85.8	1.2
142	84.6	2.4
138	83.4	3.6
133	82.2	4.8

# DCA-150SSJU — OUTPUT TERMINAL PANEL OVERVIEW

## How to read the output terminal gauges.

The gauges and knobs on the control panel **DO NOT** effect the generator output in any fashion. They are there to simply help the operator observe how much power is being supplied produced at the UVWO legs.

When the voltage selector switch is in the 240/120V position (see figure 12), place the AC Voltmeter Change-over switch to the W-U position and the AC ammeter Change-over Switch to the U or W position to read the output on the selected leg.

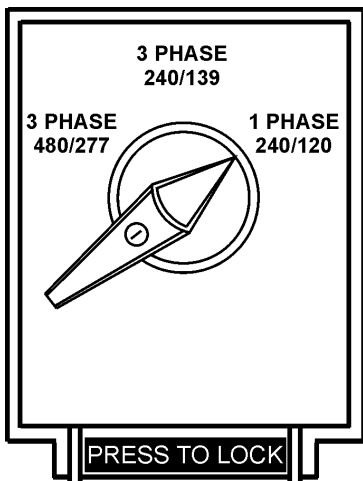


FIGURE 12. Voltage Selector Switch 240/120V Single Phase Position

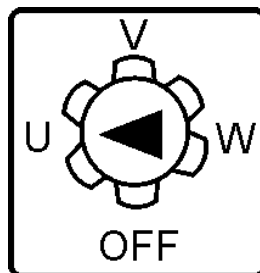


FIGURE 15. AC Ammeter Change-over Switch (Reading the U leg on the output terminal panel)

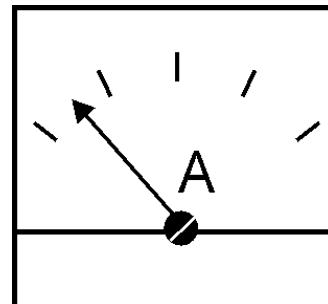


FIGURE 16. AC Ammeter (Amp reading on U lug)

### NOTE

When using plural single phase voltages, make sure to balance the load on each of the single phase legs.

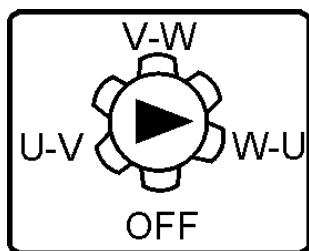


FIGURE 13. AC Voltmeter Change-over switch (Reading the W-U leg on the output terminal panel)

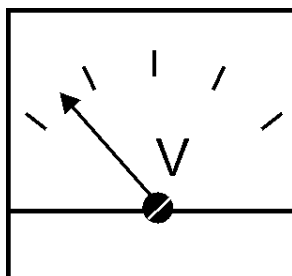


FIGURE 14. AC Voltmeter Gauge (Volt reading on W-U Lug)

# DCA-150SSJU — OUTPUT TERMINAL PANEL OVERVIEW

## 240/120V Hard Wire Hookup

The output terminal panel, when supplying single phase 120 volts, will provide three legs available with 333.3 amps each on three different circuits. (See Figure 18 below.) The voltage selector switch must be set at the single phase 240/120V position. (See figure 17 below.)

The output terminal panel, when supplying single phase 240 volts, will provide one leg only with 166.7 amps available. (See Figure 18 below.) The voltage selector switch must be set at the single phase 240/120V position. (See figure 17 below.)

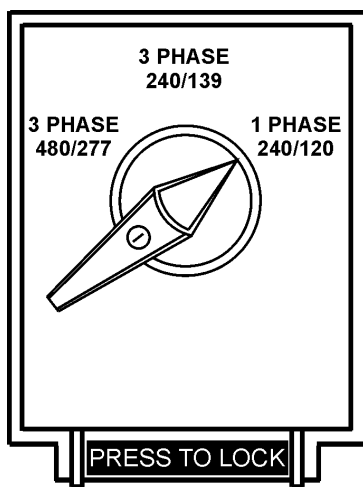


FIGURE 17. Voltage Selector Switch 240/120V Single Phase Position

## 480/240V Hard Wire Hookup

The output terminal panel, when supplying three phase 240 volts, will provide one circuit available at 361 amps with any two wires plus the ground. (See Figure 20 below.) The voltage selector switch must be set at the three phase 480/277V position. (See figure 19 below.)

The output terminal panel, when supplying 3 phase 480 volts, will provide one circuit available at 180 amps available with all three wires plus ground. (See Figure 20 below.) The voltage selector switch must be set at the three phase 480/277V position. (See figure 19 below.)

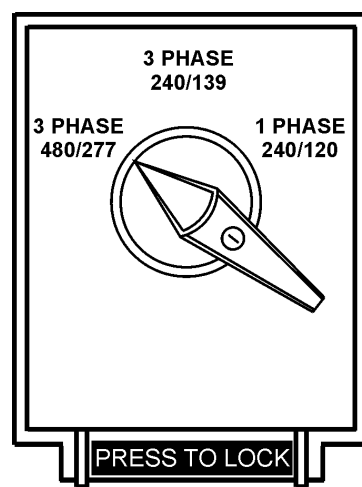


FIGURE 19. Voltage Selector Switch 480/277V Three Phase Position

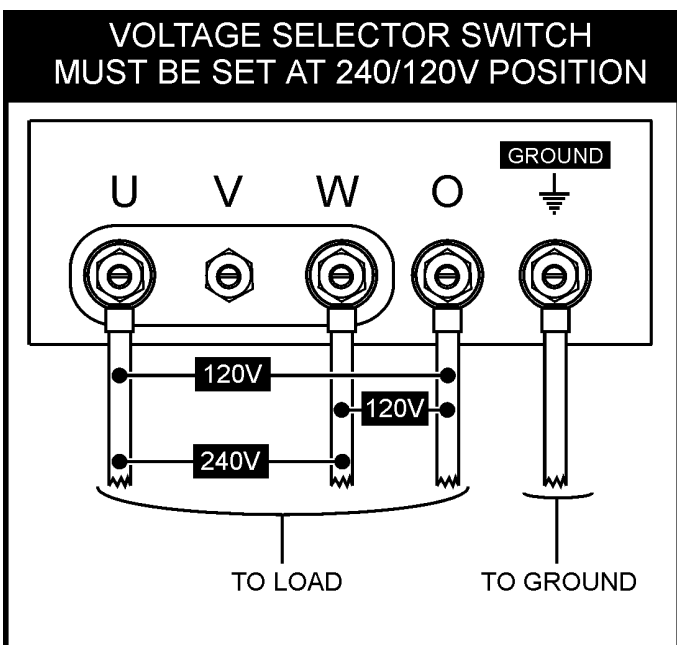


FIGURE 18. Hard Wire Hookup at 240/120V Position

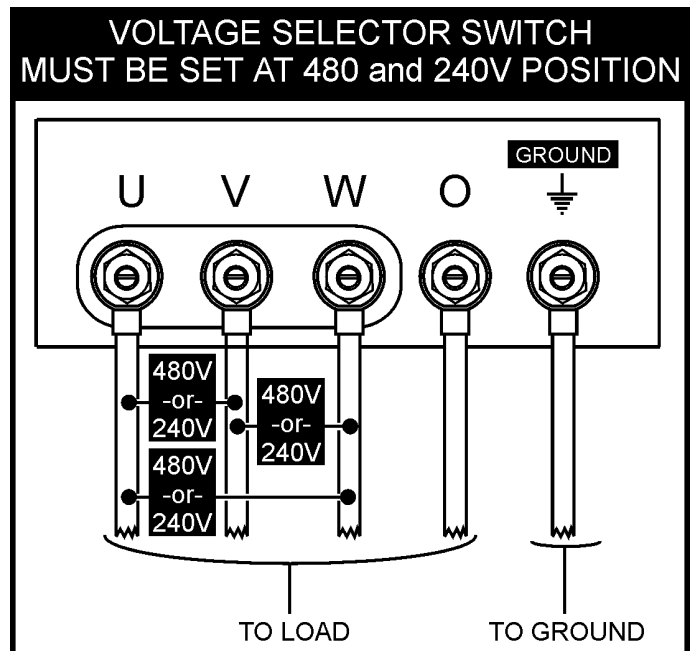


FIGURE 20. Hard Wire Hookup at 480/240V Position

# DCA-150SSJU — OUTPUT TERMINAL PANEL OVERVIEW

## Voltage Selector Switch- 3 Phase 480/277V Position

The following are additional voltages available when the voltage selector switch is in the 3 phase 480/277V position. (See figure 21 below.)

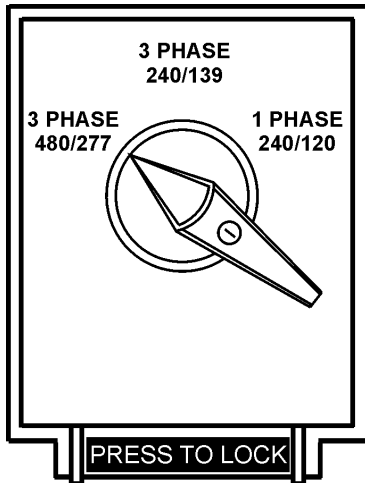


FIGURE 21. Voltage Selector Switch 480/277V Single Phase Position

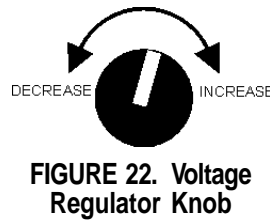


FIGURE 22. Voltage Regulator Knob

## Single Phase: 480V, 440V, or 416 Volt

The following connection, with the voltage selector switch locked into the 3 phase 480/277V position (See Figure 21), can offer **SINGLE PHASE** power at 480V, 440V, or 416V. After hooking up the hard wires to the lugs as shown in figure 24 below, 480V will be the voltage with the Voltage Regulator Knob turned toward maximum. 440 volt will be reached when the Voltage Regulator Knob is turned down, and 416 volt when the Voltage Regulator Knob is toward the lowest setting (See Figure 22).

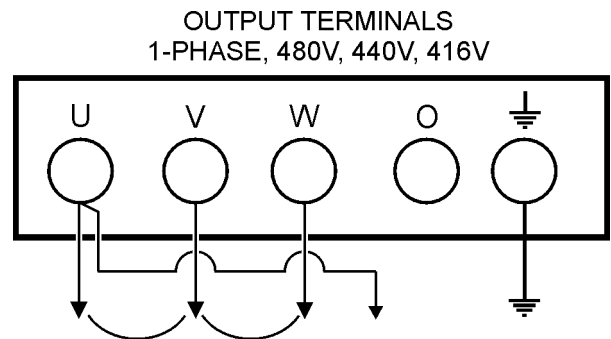


FIGURE 24. Hard Wire Hookup for Single Phase 480V, 440V, or 416V

## 3 Phase, 480V, 440V, or 416 Volt

The following connection, with the voltage selector switch locked into the 3 phase 480/277V position (See Figure 21), can offer **THREE PHASE** power at 480V, 440V, or 416V. After hooking up the hard wires to the lugs as shown in figure 23 below, 480V will be the voltage with the Voltage Regulator Knob turned toward maximum. 440 volt will be reached when the Voltage Regulator Knob is turned down, and 416 volt when the Voltage Regulator Knob is toward the lowest setting (See Figure 22).

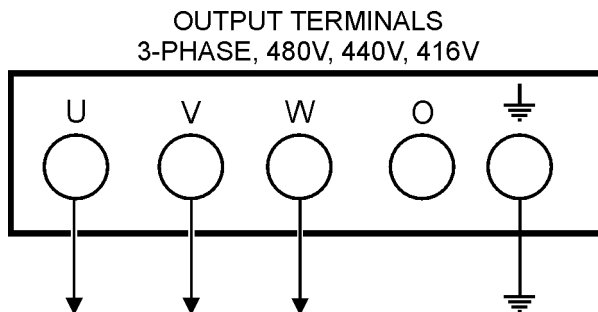


FIGURE 23. Hard Wire Hookup for Three Phase 480V, 440V, or 416V

## Single Phase: 277V, 254V, or 240V

The following connection, with the voltage selector switch locked into the 3 phase 480/277V position (See Figure 21), can offer **SINGLE PHASE** power at 277V, 254V, or 240V. After hooking up the hard wires to the lugs as shown in figure 25 below, 277V will be the voltage with the Voltage Regulator Knob turned toward maximum. 254 volt will be reached when the Voltage Regulator Knob is turned down, and 240 volt when the Voltage Regulator Knob is toward the lowest setting (See Figure 22).

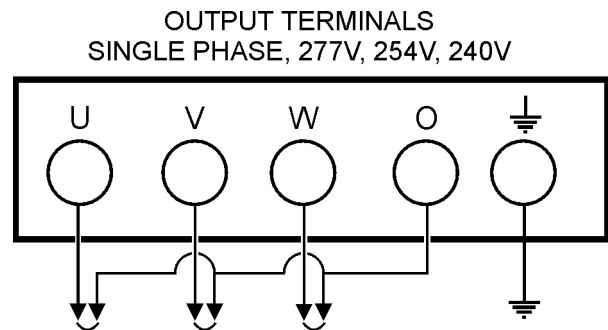


FIGURE 25. Hard Wire Hookup for Single Phase 277V, 254V, or 240V

# DCA-150SSJU — OUTPUT TERMINAL PANEL OVERVIEW

## Voltage Selector Switch- 3 Phase 240/139V Position

The following are additional voltages available when the voltage selector switch is in the 3 phase 240/139V position. (See Figure 26 below.)

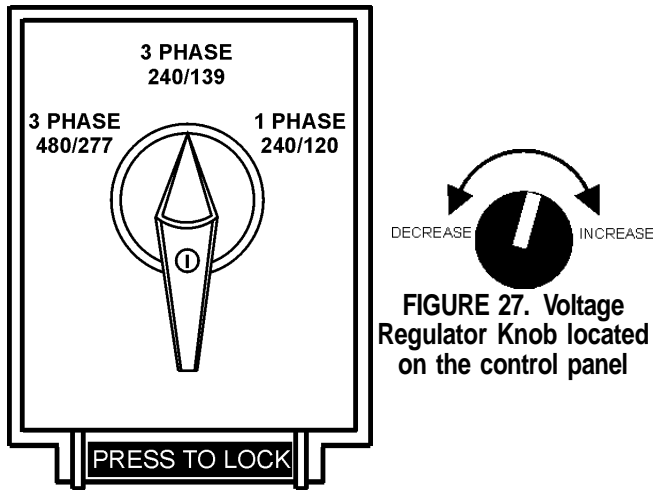


FIGURE 26. Voltage Selector Switch 240/139V Three Phase Position

## 3 Phase, 240V, 220V, or 208 Volt

The following connection, with the voltage selector switch locked into the 3 phase 240/139V position (See Figure X), can offer **THREE PHASE** power at 240V, 220V, or 208V. After hooking up the hard wires to the lugs as shown in figure 28 below, 240V will be the voltage with the Voltage Regulator Knob turned toward maximum. 220 volt will be reached when the Voltage Regulator Knob is turned down, and 208 volt when the Voltage Regulator Knob is toward the lowest setting (See Figure 27).

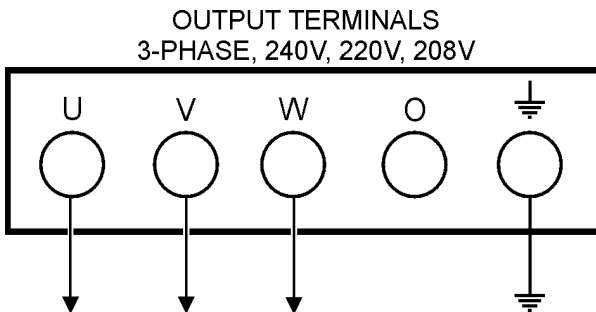


FIGURE 28. Hard Wire Hookup for Three Phase 240V, 220V, or 208V

## Single Phase: 240V, 220V, or 208 Volt

The following connection, with the voltage selector switch locked into the 3 phase 240/139V position (See Figure X), can offer **SINGLE PHASE** power at 240V, 220V, or 208V. After hooking up the hard wires to the lugs as shown in figure 29 below, 240V will be the voltage with the Voltage Regulator Knob turned toward maximum. 220 volt will be reached when the Voltage Regulator Knob is turned down, and 208 volt when the Voltage Regulator Knob is toward the lowest setting (See Figure 27).

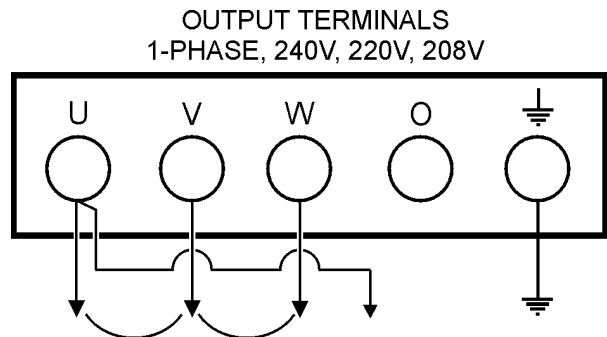


FIGURE 29. Hard Wire Hookup for Single Phase 240V, 220V, or 208V

## Single Phase: 139V, 127V, or 120V

The following connection, with the voltage selector switch locked into the 3 phase 240/139V position (See Figure 26), can offer **SINGLE PHASE** power at 139V, 127V, or 120V. After hooking up the hard wires to the lugs as shown in figure 30 below, 139V will be the voltage with the Voltage Regulator Knob turned toward maximum. 127 volt will be reached when the Voltage Regulator Knob is turned down, and 120 volt when the Voltage Regulator Knob is toward the lowest setting (See Figure 27).

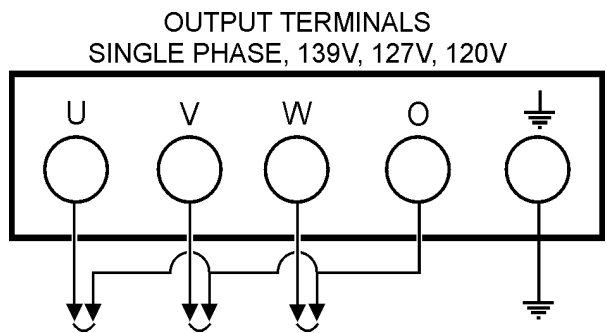


FIGURE 30. Hard Wire Hookup for Single Phase 139V, 127V, or 120V

# DCA-150SSJU — OUTPUT TERMINAL PANEL OVERVIEW

## Voltage Selector Switch- Single Phase 240/120V Position

The following are additional voltages available when the voltage selector switch is in the single phase 240/120V position. (See Figure 31 below.)

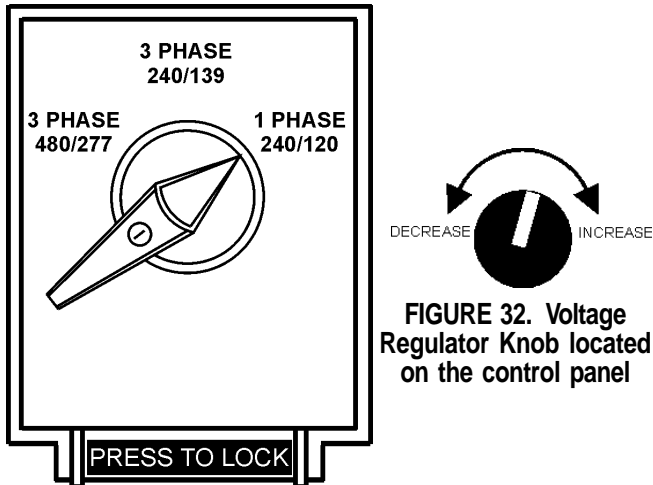


FIGURE 31. Voltage Selector Switch 240/120V Single Phase Position

## Single Phase: 120 Volt

The following connection, with the voltage selector switch locked into the single phase 240/120V position (See Figure 31), will offer **SINGLE PHASE** power at 120V. After hooking up the hard wires to the lugs as shown in figure 34 below, use the Voltage Regulator Knob to fine tune to 120V. (See Figure 32).

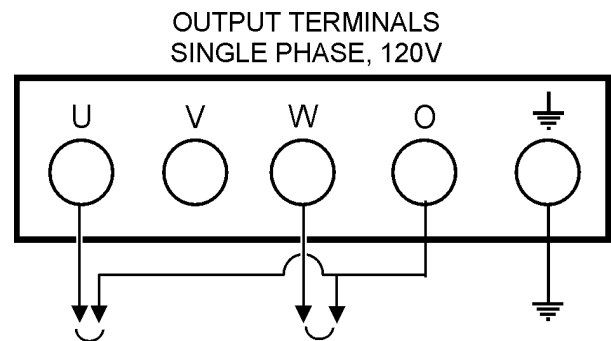


FIGURE 34. Hard Wire Hookup for Single Phase, 120 volt

## Single Phase, 240 Volt

The following connection, with the voltage selector switch locked into the single phase 240/120V position (See Figure 31), will offer **SINGLE PHASE** power at 240V. After hooking up the hard wires to the lugs as shown in figure 33 below, use the Voltage Regulator Knob to fine tune to 240V. (See Figure 32).

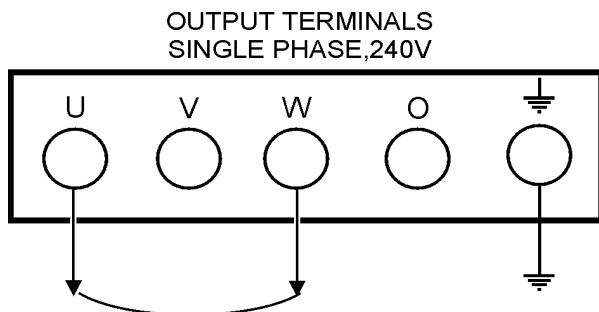


FIGURE 33. Hard Wire Hookup for Single Phase 240 volt

## Outdoor Installation

Install the generator in a location where it will not be exposed to rain or sunshine. Make sure the generator is on secure level ground so it cannot slide or shift around. Also install the generator so the exhaust will not be discharged in the direction of nearby homes.

The installation site must be relatively free from moisture and dust. All electrical equipment should be protected from excessive moisture. Failure to do will result in deterioration of the insulation and will result in short circuits and grounding.

Foreign materials such as dust, sand, lint and abrasive materials have a tendency to cause excessive wear to the engine and alternator parts.

## CAUTION :



Pay close attention to ventilation when operating the generator inside tunnels and caves. The engine exhaust contains noxious elements. Engine exhaust must be routed to a ventilated area.

## Indoor Installation

Exhaust gases from diesel engines are extremely poisonous. Whenever an engine is installed indoors the exhaust fumes must be vented to the outside. The engine should be installed at least two feet from any outside wall. Using an exhaust pipe which is too long or too small can cause excessive back pressure which will cause the engine to heat excessively and possibly burn the valves.

## CAUTION :



An electric shock may happen when vibrators are used. Pay close attention to handling when operating vibrators and always use rubber boots and gloves to insulate the body from electrical shock.

## Generator Grounding

To guard against electrical shock and possible damage to the equipment, it is important to provide a good **EARTH** ground.

Article 250 (Grounding) of the National Electrical Code (NEC) provides guide lines for proper grounding and specifies that the cable ground shall be connected to the grounding system of the building as close to the point of cable entry as practical.

NEC articles 250-64(b) and 250-66 set the following grounding requirements:

1. Use one of the following wire types to connect the generator to earth ground.
  - a. Copper - 10 AWG (5.3 mm<sup>2</sup>) or larger.
  - b. Aluminum - 8 AWG (8.4 mm<sup>2</sup>) or larger.
2. When grounding the generator (Figure 8) connect the ground cable between the lock washer and the nut on the generator and tighten the nut fully. Connect the other end of the ground cable to earth ground.
3. NEC article 250-52(c) specifies that the earth ground rod should be buried a minimum of 8 ft. into the ground.

## NOTE

When connecting the generator to any buildings electrical system **ALWAYS** consult with a licensed electrician.

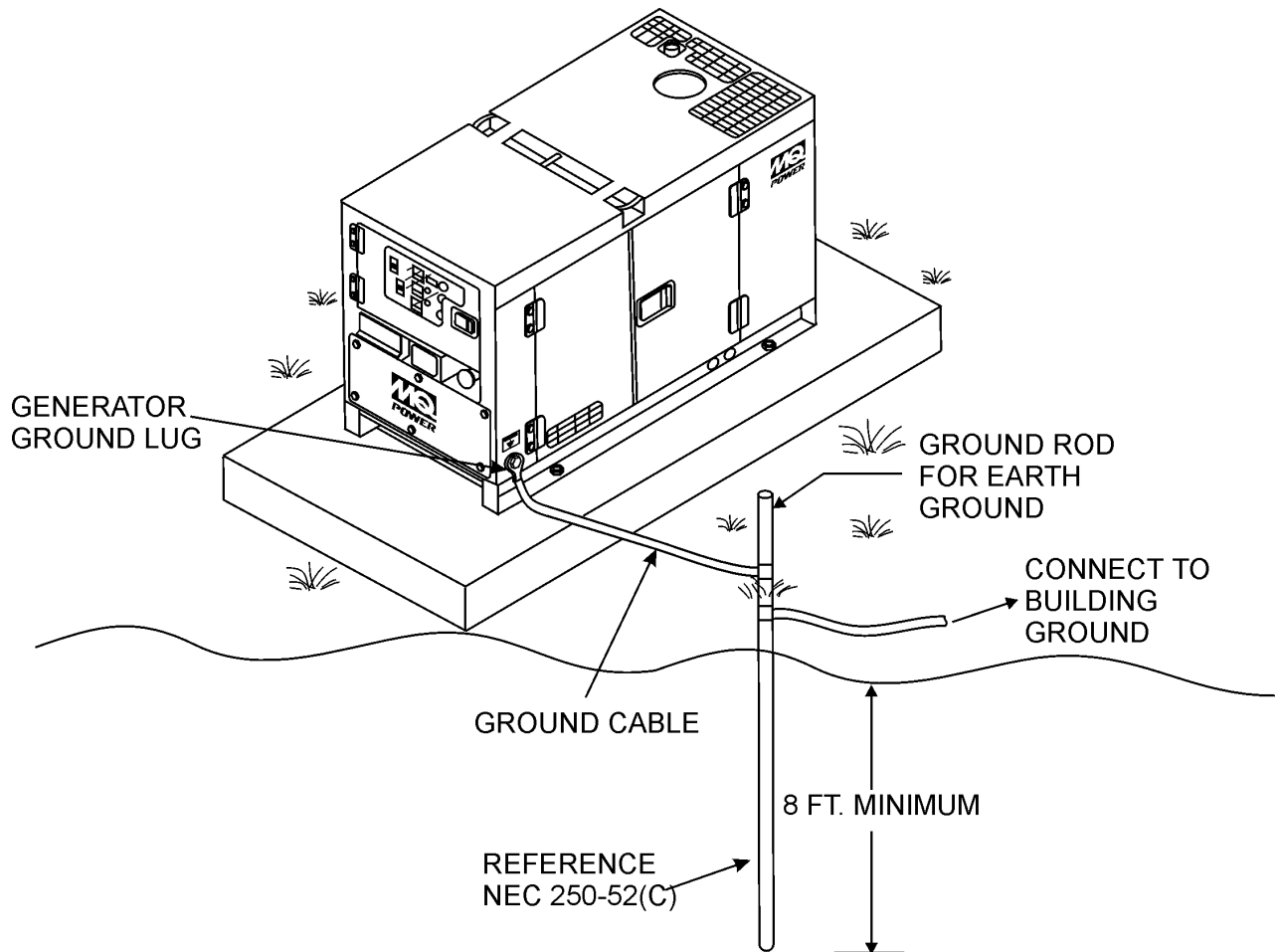


Figure 35. Typical Generator Grounding Application

**CAUTION :**



Always check Local, State, and Federal laws before grounding generator set.

## General Inspection Prior to Operation

The DCA-150SSJU generator has been thoroughly inspected and accepted prior to shipment from the factory. However, be sure to check for damaged parts or components, or loose nuts and bolts, which could have occurred in transit.

## Extension Cable

When electric power is to be provided to various tools or loads at some distance from the generator, extension cords are normally used. Cables should be sized to allow for distance in length and amperage so that the voltage drop between the generator and point of use (load) is held to a minimum. Use the Cable Selection Guide (Table 11) as a guide for selecting proper cable size.

## Circuit Breakers

To protect the generator from an overload, a 3-pole, 400 amp, **main** circuit breaker is provided to protect the UNV output terminals from overload. In addition two single-pole, 20 amp **GFCI** circuit breakers are provided to protect the GFCI receptacles from overload. Three 50 amp **load** circuit breakers have also been provided to protect the load side of the generator from overload. Make sure to switch **ALL** circuit breakers to the "OFF" position prior to starting the engine.

### NOTE

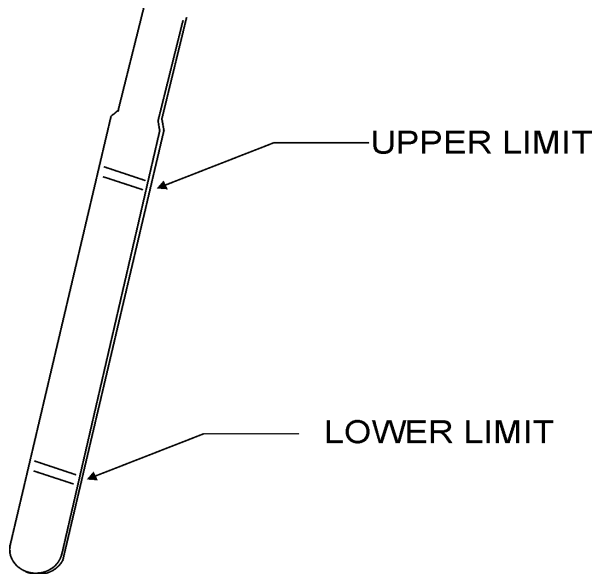
**ALWAYS** consult with a licensed electrician for correct extension cord wire size.

**Table 11. Cable Selection (60 Hz, Single Phase Operation)**

Current in Amperes	Load In Watts		Maximum Allowable Cable Length			
	At 120 Volts	At 240 Volts	#10 Wire	#12 Wire	#14 Wire	#16 Wire
2.5	300	600	1000 ft.	600 ft.	375 ft.	250 ft.
5	600	1200	500 ft.	300 ft.	200 ft.	125 ft.
7.5	900	1800	350 ft.	200 ft.	125 ft.	100 ft.
10	1200	2400	250 ft.	150 ft.	100 ft.	
15	1800	3600	150 ft.	100 ft.	65 ft.	
20	2400	4800	125 ft.	75 ft.	50 ft.	
CAUTION: Equipment damage can result from low voltage.						

## Lubrication Oil

Fill the engine crankcase with lubricating oil through the filler hole, but do not overfill. Make sure the generator is level. With the dipstick inserted all the way, but without being screw into the filler hole, verify that the oil level is maintained between the two notches (Figure 36) on the dipstick. See Table 12 for proper selection of engine oil.



**Figure 36. Engine Oil Dipstick**

When checking the engine oil, be sure to check if the oil is clean and viscous. If the oil is not clean, drain the oil by removing the oil drain plug, and refill with the specified amount of oil as outlined in the **John Deere Engine Owner's Manual**.

## Fuel

Fill the fuel tank with clean and fresh **diesel fuel**. **DO NOT** fill the tank beyond capacity.

Pay attention to the fuel tank capacity when replenishing fuel. Refer to the fuel tank capacity listed on page 23, Specification Table 7.

The fuel tank cap must be closed tightly after filling. Handle fuel in a safety container. If the container does not have a spout, use a funnel. Wipe up any spilled fuel immediately.

## CAUTION:



Never fill the fuel tank while the engine is running or in the dark. Diesel spillage on a hot engine can cause a fire or explosion. If diesel spillage occurs, wipe up the spilled diesel completely to prevent fire hazards.

## Coolant

Use only drinkable tap water. If hard water or water with many impurities is used, the inside of the engine and radiator may become coated with deposits and cooling efficiency will be reduced.

An anticorrosion additive added to the water will help prevent deposits and corrosion in the cooling system. See the engine manual for further details.

**Table 12. Recommended Motor Oil**

Temperature Range	Type Oil
104° F ~ 23° F (40° C ~ -5°C)	SAE 30
23° F ~ 5° F (-5° C ~ -15°C)	SAE 20 or SAE 10W-30
Below 5° C (-15°)	SAE 10W or SAE 10W-30

## CAUTION :



When adding coolant or antifreeze to the radiator, do not remove the radiator cap until the unit has completely cooled.

Day-to-day addition of coolant is done from the reserve tank. When adding coolant to the radiator, **DO NOT** remove the radiator cap until the unit has completely cooled. See Table 13 for engine, radiator, and reserve tank coolant capacities. Make sure the coolant level in the reserve tank is always between the "H" and the "L" markings.

**Table 13. Coolant Capacity**

Engine and Radiator	10.9 Gal. (41 Liters)
Reserve Tank	2 Quarts (11.9 Liters)

### Operation in Freezing Weather

When operating in freezing weather, be certain the proper amount of antifreeze (Table 14) has been added.

**Table 14. Anti-Freeze Operating Temperatures**

Vol % Anti-Freeze	Freezing Point		Boiling Point	
	°C	°F	°C	°F
40	-24	-12	106	222
50	-37	-34	108	226

#### NOTE

***When the antifreeze is mixed with water, the antifreeze mixing ratio must be less than 50%.***

### Cleaning the Radiator

The engine may overheat if the radiator fins become overloaded with dust or debris. Periodically clean the radiator fins with compressed air. Cleaning inside the machine is dangerous, so clean only with the engine turned off and the battery disconnected.

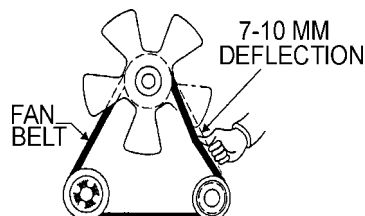
### Air Cleaner

Periodic cleaning/replacement is necessary. Inspect it in accordance with the **John Deere Engine Owner's Manual**.

### Fan Belt Tension

A slack fan belt may contribute to overheating, or to insufficient charging of the battery. Inspect the fan belt for damage and wear and adjust it in accordance with the **John Deere Engine Owner's Manual**.

The fan belt tension is proper if the fan belt bends 7 to 10 mm (Figure 37) when depressed with the thumb as shown below.



**Figure 37. Fan Belt Tension**

## CAUTION :



Never place hands near the belts or fan while the generator set is running.

### Battery

This unit is of negative ground **DO NOT** connect in reverse. Always maintain battery fluid level between the specified marks. Battery life will be shortened, if the fluid level is not properly maintained. Add only distilled water when replenishment is necessary.

The battery is sufficiently charged if the specific gravity of the battery fluid is 1.28 (at 68°F). If the specific gravity should fall to 1.245 or lower, it indicates the battery is discharged and needs to be recharged or replaced.

Check to see whether the battery cables are loose. Poor contact may result in poor starting or malfunctions. Always keep the terminals firmly tightened. Coating the terminals with a thin film of grease will help inhibit corrosion.

## Battery Cable Installation

**ALWAYS** be sure the battery cables (Figure 38) are properly connected to the battery terminals as shown below. The **RED** cable is connected to the positive terminal of the battery, and the **BLACK** cable is connected to the negative terminal of the battery.

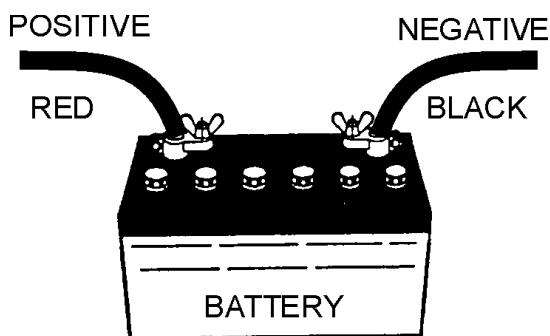


Figure 38. Battery Connections

## CAUTION :



If the battery cable is connected incorrectly, electrical damage to the generator will occur. Pay close attention to the polarity of the battery when connecting the battery.

When connecting battery do the following:

1. **DO NOT** connect the battery cables to the battery terminals when the **Off/Manual/Auto** switch is in either the manual or auto position (ON) if the generator is installed with a microprocessor engine controller. **ALWAYS** make sure that the Off/Manual/Auto switch is in the OFF position when connecting the battery. If the generator is equipped with an ignition switch, make sure the key is removed from the switch and is at
2. Place a small amount of grease around both battery terminals. This will ensure a good connection and will help prevent corrosion around the battery terminals.

## CAUTION :



Inadequate battery connections may cause poor starting of the generator, and create other malfunctions.

## Wiring

Inspect the entire generator for bad or worn electrical wiring or connections. If any wiring or connections are exposed (insulation missing) replace wiring immediately.

## Piping and Hose Connection

Inspect all piping, oil hose, and fuel hose connections for wear and tightness. Tighten all hose clamps and check hoses for leaks.

If any hose (fuel or oil) lines are defective replace them immediately.

## Ether Canister Operation

To bleed the ether, crank the engine for at least two revolutions, then momentarily depress the starting aid button while the engine is cranking. If the engine does not start, repeat the cranking process using only short bursts of ether only while the engine is cranking. Stop injecting the fluid after then engine starts. If the engine begins to die during the first few minutes of operation, inject another small shot of ether.

## CAUTION :



Use only ether starting fluid while the engine is turning or damage may occur.

## WARNING :



Ether is highly flammable. Do not use near open fires, flames, or sparks.

## Single Phase Load

Always be sure to check the nameplate on the generator and equipment to insure the wattage, amperage and frequency requirements are satisfactorily supplied by the generator for operating the equipment.

Generally, the wattage listed on the nameplate of the equipment is its rated output. Equipment may require 130—150% more wattage than the rating on the nameplate, as the wattage is influenced by the efficiency, power factor and starting system of the equipment.

**NOTE**

If wattage is not given on the equipment's name plate, approximate wattage may be determined by multiplying nameplate voltage by the nameplate amperage.

WATTS = VOLTAGE x AMPERAGE

The power factor of this generator is 0.8. See Table 15. below when connecting loads.

Type Of Load	Power Factor
Single-phase induction motors	0.4 - 0.75
Electric heaters, incandescent lamps	1.0
Fluorescent lamps, mercury lamps	0.4 - 0.9
Electronic devices, communication equipment	1.0
Common power tools	0.8

## Three Phase Load

When calculating the power requirements for 3-phase power use the following equation:

$$KVA = \frac{VOLTAGE \times AMPERAGE \times \sqrt{3}}{1000}$$

## CAUTION:



Motors and motor-driven equipment draw much greater current for starting than during operation.

An inadequate size connecting cable which cannot carry the required load can cause a voltage drop which can burn out the appliance or tool and overheat the cable.

- When connecting a resistance load such as an incandescent lamp or electric heater, a capacity of up to the generating set's rated output (kW) can be used.
- When connecting a fluorescent or mercury lamp, a capacity of up to the generating set's rated output (kW) multiplied by 0.6 can be used.
- When connecting an electric drill or other power tools, pay close attention to the required starting current capacity.

When connecting ordinary power tools, a capacity of up to the generating set's rated output (kW) multiplied by 0.8 can be used.

## CAUTION:



Before connecting this generator to any building's electrical system, a licensed electrician must install an isolation (transfer) switch. Serious injury or death may result without this transfer switch.

**NOTE**

If output (kVA) is not given on the equipment nameplate, approximate output may be determined by multiplying voltage by amperage by  $\sqrt{3}$

# DCA-150SSJU — GENERATOR START-UP PROCEDURE

## WARNING:



The engine's exhaust contains harmful emissions. **ALWAYS** ventilate the exhaust when operating inside tunnels, excavations or buildings. Direct exhaust away from nearby personnel.

### Before Starting Engine

1. Check the lubricating oil level prior to starting the engine. Make sure the generator is level. The oil level must be maintained between two notches on the dipstick.
2. When there is not enough lubricating oil, fill the crankcase with high grade motor oil. Use a high quality detergent oil classified CC or higher (See Table 12 on page 43).
3. Check the coolant level in the radiator and subtank. Replenish with antifreeze as necessary. Always maintain the coolant level between the **FULL** and **LOW** markings on the coolant container. Be sure that the radiator cap is fastened securely.
4. Check the fuel level on the fuel gauge. If fuel is low, fill the fuel tank with clean fresh unleaded automotive diesel. If diesel spillage occurs, completely wipe up the spilled fuel immediately.

### Before Starting

#### Generator and Control Panel

## CAUTION:



● **NEVER** start the engine with the **main**, **GFCI** or **load** circuit breakers in the **ON** position.

1. Be sure to disconnect the electrical load and switch the **main**, **load** and **G.F.C.I.** circuit breakers (Figure 39) to the "OFF" position prior to starting the engine.

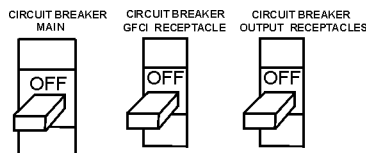


Figure 39. Main, GFCI and Load Circuit Breakers

2. Connect the load to the UNV terminals as shown in Figure 40. These terminals can be found on the output terminal panel, (see page 11 Figure 33). To gain access to the output terminals lift the UNV cover. Tighten terminal nuts securely to prevent load wires from slipping out.

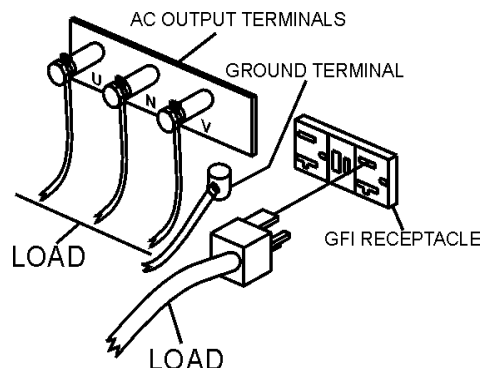


Figure 40. UNV Terminal Lugs (Load)

3. Connect the negative battery cable (BLACK) to the negative post on the battery (Figure 41).

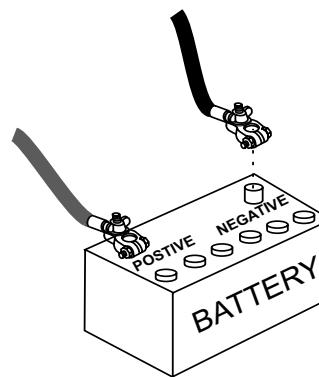
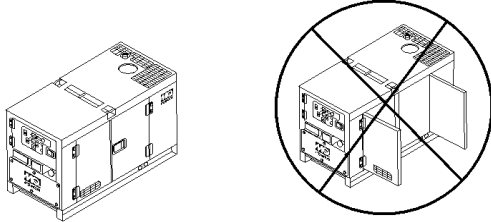


Figure 41. Battery Connections

# DCA-150SSJU — GENERATOR START-UP PROCEDURE

5. Close all engine enclosure doors (Figure 42).



CORRECT

INCORRECT

Figure 42. Engine Enclosure Doors

6. When starting the generator in **COLD** weather conditions, press and hold the engine preheat button (Figure 43).



Figure 43. Engine Pre-Heat Button

7. Check the engine throttle lever is in 'low' position (Figure 44).

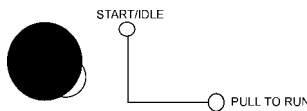


Figure 44. Engine Throttle Lever (low)

8. Turn the key to 'Start' until the engine starts (Figure 45). Then release the key to 'Run'.



Figure 45. Ignition Switch (Start)

9. Place the Off/Manual/Auto switch (Figure 46) in the **MANUAL** position (down). Observe that the engine begins to crank (iff applicable).

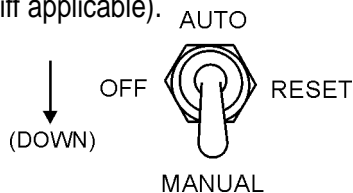


Figure 46. Off/Manual/Auto Switch (Manual)

10. After engine starts, verify that the "Engine Running" status LED (Figure 47) on the Microprocessor Engine Control Module (MPEC) display is "ON" (lit) (if applicable).



Figure 47. MPEC Engine Running Status LED

11. Let the engine warm up for a few minutes. Then pull and turn the throttle lever to the right to set the engine speed to 'high' (Figure 48).

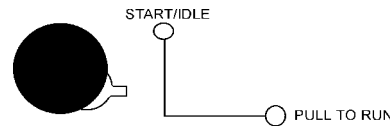


Figure 48. Engine Throttle Lever (high)

12. The generator's frequency meter (Figure 49) displays the 60 cycle output frequency in **HERTZ**.

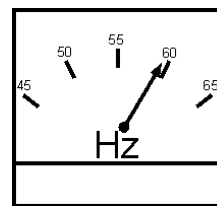
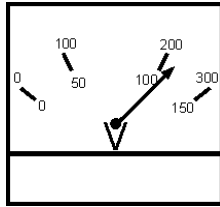


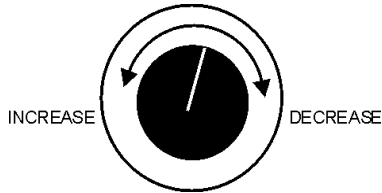
Figure 49. Frequency Meter (Hz)

13. The generator's voltage meter (Figure 50) displays the 120 VAC in **VOLTS**. If the voltage is not within the specified frequency tolerance, use the voltage adjustment control knob (Figure 51) to increase or decrease the desired voltage.

# DCA-150SSJU — GENERATOR START-UP PROCEDURE

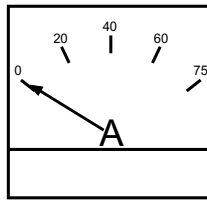


**Figure 50. Voltage Meter (Volts)**



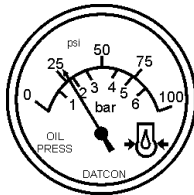
**Figure 51. Voltage Adjust Control Knob**

14. The ammeter (Figure 52) will indicate zero amps with no load applied. When a load is applied, this meter will indicate the amount of current that the load is drawing from the generator's alternator.



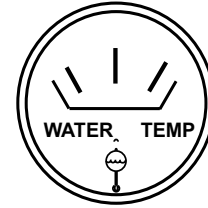
**Figure 52. Ammeter (No Load)**

15. The engine oil pressure gauge (Figure 53) will indicate the oil pressure (kg/cm<sup>2</sup>) of the engine. Under normal operating conditions the oil pressure is approximately 25 psi.



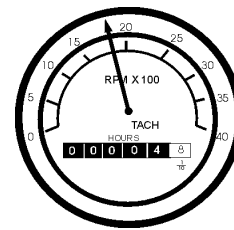
**Figure 53. Oil Pressure Gauge**

16. The coolant temperature gauge (Figure 54) will indicate the coolant temperature. Under normal operating conditions the coolant temperature is between 165 and 215 degrees Fahrenheit (Green Zone).



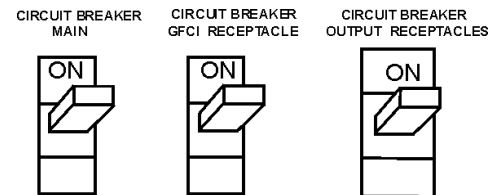
**Figure 54. Coolant Temperature Gauge**

17. The tachometer (Figure 55) will indicate the speed of the engine when the generator is operating. Under normal operating conditions this speed is approximately 1800 RPM's.



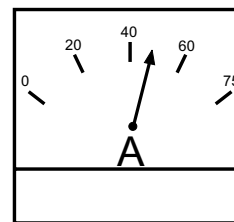
**Figure 55. Engine Tachometer**

18. Turn the MAIN, GFCI and LOAD circuit breakers to their ON position (Figure 56).



**Figure 56. Main and GFCI Circuit Breakers**

19. Observe the generator's ammeter (Figure 57) and verify it reads the anticipated amount of current with respect to the load. The ammeter will only display a current reading if the load is in use.



**Figure 57. Ammeter (Load)**

20. The generator will run until manually stopped or an abnormal condition occurs.

# DCA-150SSJU — GENERATOR SHUTDOWN PROCEDURE

With an Engine Controller, starting the generator in the "AUTO" mode is similar to starting the generator in the "MANUAL" mode, with a few exceptions.

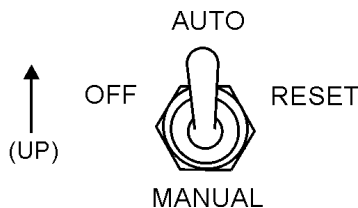
## CAUTION:



When running the generator in the **AUTO** mode, remember the generator can start up at any time without warning. **NEVER** attempt to perform any maintenance when the generator is in the auto mode.

When starting generator in Auto mode use the "Manual Start-up" procedure except where noted (see below).

1. Perform steps 1 through 7 (Before Starting, page 47-48) as outlined in the manual starting procedure.
2. Place the Off/Manual/Auto switch (Figure 58) in the **AUTO** position (up).



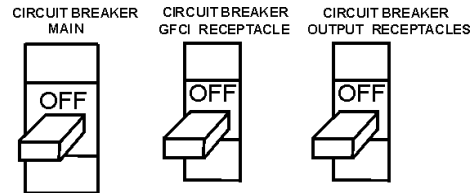
**Figure 58. Off/Manual Auto Switch (AUTO)**

5. Continue to follow the steps outline in the manual start-up procedure (start at step 11, page 32).

## ENGINE SHUTDOWN

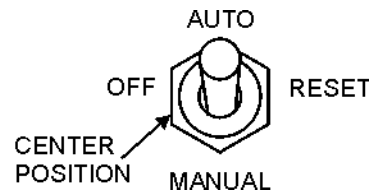
To shutdown the generator, use the following procedure:

1. Switch both the MAIN, GFCI and LOAD circuit breakers (Figure 59) to the "OFF" position.



**Figure 59. Main, GFCI and Load circuit breakers**

2. Set the engine throttle lever to the idle (low) position.
  3. Let the engine cool by running it for 3-5 minutes with no load applied.
  4. Turn the starter switch to "OFF" position.
- OR
4. Place the Off/Manual/Auto Switch (Figure 60) in the "**OFF/RESET**" position (if applicable).



**Figure 60. Off/Manual Auto Switch (OFF)**

5. Verify that the "Engine Running" status LED (Figure 61) on the Microprocessor Engine Control Module (MPEC) display is "OFF" (not lit).



**Figure 61. MPEC Engine Running Status LED (OFF)**

6. Remove the load from the UNV terminal strip.



## General Inspection

Prior to each use, the generating set should be cleaned and inspected for deficiencies. Check for loose, missing or damaged nuts, bolts or other fasteners. Also check for fuel or oil leaks.

**Engine Side, Fuel, Oil and Coolant** (Refer to the Engine Instruction Manual)

## Air Cleaner

Every 50 hours: Remove air cleaner element and clean heavy duty paper element with kerosene, or foam element with liquid detergent and hot water. Wrap foam element in a cloth and squeeze dry. For heavy duty paper element, wipe excess kerosene with towel.

## Fuel Addition

Add diesel fuel (the grade may vary according to season and locations). Always pour through the mesh filter.

## Removing Water from the Tank

After prolonged use, water and other impurities accumulate in the bottom of the tank. Occasionally remove the drain cock and drain the contents. During cold weather, the greater the empty volume inside the tank, the easier it is for water to condense. This can be reduced by always keeping the tank as full as possible.

## Air Removal

If air enters the fuel injection system of a diesel engine, starting becomes impossible. After running out of fuel, or after disassembling the fuel system, bleed the system according to the following procedure.

To restart after running out of fuel, turn the key switch to the "START" position for 15-30 seconds. Try again, if needed. This unit is equipped with an automatic air bleeding system.

## Service Daily

If engine is operating in very dusty and dry grass conditions, a clogged air cleaner will result in high fuel consumption, loss of power and excessive carbon buildup in the combustion chamber.

## Cleaning the Fuel Strainer

Clean the fuel strainer if it contains dust or water. Remove dust or water in the strainer cap and wash it in diesel. Securely fasten the fuel strainer cap so that fuel will not leak. Check the fuel strainer every 200 hours of operation or once a month.

## Check Oil Level

Check the crankcase oil level prior to each use, or when the fuel tank is filled. Insufficient oil may cause severe damage to the engine. Make sure the generator is level. The oil level must be between the two notches on the dipstick as shown in page 27, Figure 9.

## Cleaning and Installing Ether Canister

Remove safety cap from ether canister. Remove spray nozzle from canister. Remove the old canister assembly from the solenoid and properly dispose the old canister. Install the new canister and canister assembly to the solenoid.

## CAUTION:



Ether is highly flammable. Do not use near open fires, flames, or sparks. Do not leave the canister assembly valve open.

## Generator Storage

For storage of the generator for over 30 days, the following is required:

- Drain the fuel tank completely.
- Completely drain the oil from the crankcase and refill with fresh oil.
- Clean all external parts of the generator with a cloth.
- Cover the generating set and store in a clean, dry place.

TABLE 16.

INSPECTION / MAINTENANCE		10 Hrs DAILY	250 Hrs	500 Hrs	1000 Hrs
ENGINE	Check Engine Fluid Levels	X			
	Check Air Cleaner	X			
	Check Battery Acid Level	X			
	Check Fan Belt Condition	X			
	Check for Leaks	X			
	Check for Loosening of Parts	X			
	Replace Engine Oil and Filter * <sup>1</sup>		X		
	Clean Air Filter		X		
	Drain Bottom of Fuel Tank		X		
	Clean Unit, Inside and Outside		X		
	Change Fuel Filter * <sup>2</sup>			X	
	Replace Ether Canister			X	
	Clean Radiator and Check Coolant Protection Level			X	
	Replace Air Filter Element				X
	Change Corrosion Resistor				X
	Check all Hoses and Clamps				X
Clean Inside of Fuel Tank				X	
GENERATOR	Measure Insulation Resistance Over 3M ohms		X		

\*<sup>1</sup> Replace engine oil and filter at 100 hours, first time only.

\*<sup>2</sup> Replace fuel filter at 250 Hours, first time only.

# DCA-150SSJU — TROUBLESHOOTING (ENGINE)

Practically all breakdowns can be prevented by proper handling and maintenance inspections, but in the event of a breakdown, use the tables shown for

diagnosis based on the Engine Troubleshooting (Table 17). If the problem cannot be remedied, consult our company's business office or service plant.

## TABLE 17. ENGINE TROUBLESHOOTING

SYMPTOM	POSSIBLE PROBLEM	SOLUTION
Engine does not start.	No fuel?	Replenish fuel.
	Air in the fuel system?	Bleed system.
	Water in the fuel system?	Remove water from fuel tank.
	Fuel pipe clogged?	Clean fuel pipe.
	Fuel filter clogged?	Clean or change fuel filter.
	Excessively high viscosity of fuel or engine oil at low temperature?	Use the specified fuel or engine oil.
	Fuel with low cetane number?	Use the specified fuel.
	Fuel leak due to loose injection pipe retaining nut?	Tighten nut.
	Incorrect injection timing?	Adjust.
	Fuel cam shaft worn?	Replace.
	Injection nozzle clogged?	Clean injection nozzle.
	Injection pump malfunctioning?	Repair or replace.
	Seizure of crankshaft, camshaft, piston, cylinder liner or bearing?	Repair or replace.
	Compression leak from cylinder?	Replace head gasket, tighten cylinder head bolt, glow plug and nozzle holder.
	Improper valve timing?	Correct or replace timing gear.
	Piston ring and liner worn?	Replace.
Excessive valve clearance?	Adjust.	
Starter does not run.	Starter malfunctioning?	Repair or replace.
	Wiring disconnected?	Connect wiring.

## TABLE 17. ENGINE TROUBLESHOOTING (CONTINUED)

SYMPTOM	POSSIBLE PROBLEM	SOLUTION
Engine revolution is not smooth.	Fuel filter clogged or dirty?	Clean or change.
	Air cleaner clogged?	Clean or change.
	Fuel leak due to loose injection pipe retaining nut?	Tighten nut.
	Injection pump malfunctioning?	Repair or replace.
	Incorrect nozzle opening pressure?	Adjust.
	Injection nozzle stuck or clogged?	Repair or replace.
	Fuel over flow pipe clogged?	Clean.
	Governor malfunctioning?	Repair.
Either white or blue exhaust gas is observed.	Excessive engine oil?	Reduce to the specified level.
	Piston ring and liner worn or stuck?	Repair or replace.
	Incorrect injection timing?	Adjust.
	Deficient compression?	Adjust top clearance.
Either black or dark gray exhaust gas is observed.	Overload?	Lessen the load.
	Low grade fuel used?	Use the specified fuel.
	Fuel filter clogged?	Clean or change.
	Air cleaner clogged?	Clean or change.
	Deficient nozzle injection?	Repair or replace the nozzle.
Deficient output.	Incorrect injection timing?	Adjust.
	Engine's moving parts seem to be seizing?	Repair or replace.
	Uneven fuel injection?	Repair or replace the injection pump.
	Deficient nozzle injection?	Repair or replace the nozzle.
	Compression leak?	Replace head gasket, tighten cylinder head bolt, glow plug and nozzle holder.

# DCA-150SSJU —TROUBLESHOOTING (GENERATOR/ENGINE)

Practically all breakdowns can be prevented by proper handling and maintenance inspections, but in the event of a breakdown, use the tables shown for diagnosis based on

the Engine and Radiator Troubleshooting (Table 18) and MPEC Trouble shooting (if applicable) (Table 19) . If the problem cannot be remedied, consult our company's business office or service plant.

**TABLE 8. ENGINE & GENERATOR TROUBLESHOOTING**

SYMPTOM	POSSIBLE PROBLEM	SOLUTION
Engine fails to start and starter does not rotated.	Dead battery?	Replace battery.
	Defective starter switch?	Replace switch.
	Fuse F5 burned out?	Replace fuse.
Engine fails to start and starter rotates.	Broken pre-heat circuit?	Check pre-heat circuit.
	No fuel?	Add fuel.
	Defective wiring?	Check wiring.
Engine starts and remains at low speed.	Clogged fuel strainer?	Clean or replace.
	Clogged air cleaner?	Clean or replace.
	Disconnected wiring?	Check and repair wiring.
Engine speed rises and no voltage is present n AC power source.	No voltage present in AC power source?	Replace rectifier (RE1).
	Defective rotor?	Replace rotor.
	Defective voltmeter?	Replace voltmeter.
	Disconnected wiring?	Check and repair wiring.
	Layer short-circuit in armature winding?	Replace armature.
Engine speed rises and AC power voltage is too low or cannot be used.	Defective circuit breaker (protector)?	Replace circuit breaker (protector).
	Layer short-circuit, broken wires in armature winding?	Repair or replace armature.
Engine speed rises and battery discharges too soon.	Defective engine regulator?	Replace regulator.
	Defective wiring?	Repair or replace wiring.
Engine speed rises and engine seems overloaded.	Defective alternator?	Repair or replace alternator.
	Damaged alternator bearing?	Replace alternator bearings.

## TABLE 19. MPEC TROUBLESHOOTING

Symptom	Possible Cause	Solution
Low oil pressure light is on.	Low oil level?	Fill oil level.
	Oil pressure sending unit failure?	Replace oil pressure sending unit.
	Time delay malfunction in MPEC?	Refer to dealer.
	Wire shorted?	Inspect/repair wire.
Low coolant level light is on.	Low coolant level?	Fill coolant level.
	Sending unit failure?	Replace sending unit.
	Low battery voltage?	Replace/charge battery.
High coolant temperature light is on.	Fan belt tension incorrect?	Tighten/replace fan belt.
	Air flow is not circulation through radiator?	Clean/repair radiator grill.
	Doors open?	Close doors.
	Exhaust leaking?	Replace/repair gaskets or faulty part.
	Generator being overloaded?	Check/reduce load.
	Thermostat failure?	Replace thermostat.
	Air intake blocked?	Clear all air intakes.
	Temperature switch failure?	Replace temperature switch.
Overcrank light is on.	No or low Fuel?	Fill fuel level.
	MPEC needs to be calibrated?	Refer to dealer.
Overspeed light is on.	RPM engine speed too high?	Adjust RPM.
	Governor actuator needs to be adjusted?	Adjust governor actuator.
	Governor controller needs to be adjusted?	Adjust governor controller.
	MPEC needs to be calibrated?	Refer to dealer.
Loss of MPU light(s) or on.	Magnetic pick up out of adjustment?	Adjust magnetic pick up.
	Magnetic pick up dirty?	Clean magnetic pick up.

## EXPLANATION OF CODE IN REMARKS COLUMN

How to read the marks and remarks used in this parts book.

### Items Found In the “Remarks” Column

**Serial Numbers**-Where indicated, this indicates a serial number range (inclusive) where a particular part is used.

**Model Number**-Where indicated, this shows that the corresponding part is utilized only with this specific model number or model number variant.

### Items Found In the “Items Number” Column

All parts with same symbol in the number column, \*, #, +, %, or n, belong to the same assembly or kit.

Note: If more than one of the same reference number is listed, the last one listed indicates newest (or latest) part available.

## DCA-150SSJUW/JOHN DEERE 6081TF001 diesel ENGINE

### 1 to 5 Units

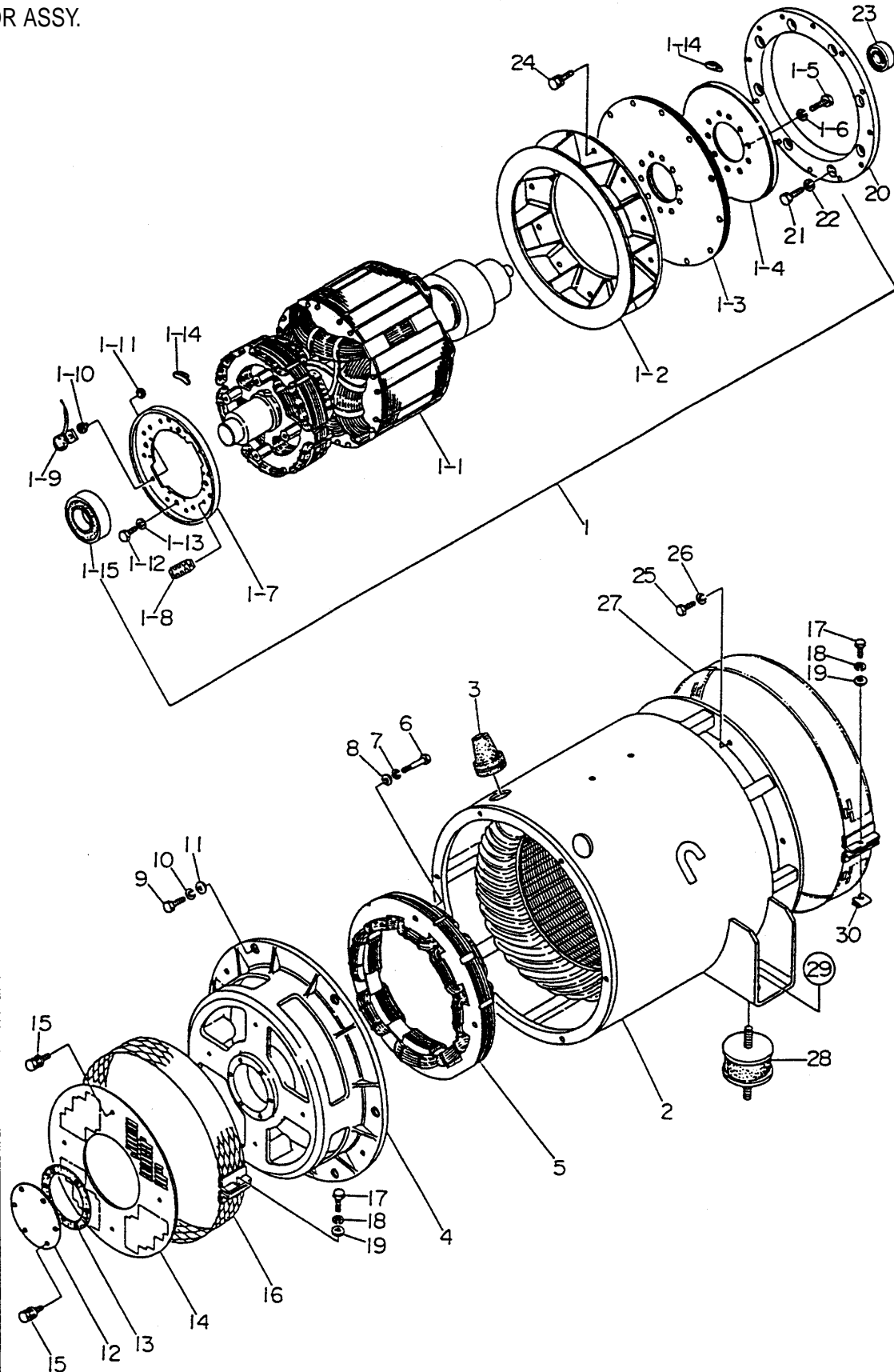
Qty.	P/N	Description
10	0602046379	AIR FILTER
10	0602042591	FUEL FILTER
10	0602041291	OIL FILTER
1	0601808803	CIRCUIT BREAKER
2	0602011492	ENGINE FAN BELT
1	0602100056	SWITCH, STARTER
5	AR51481	KEY SET, STARTER SWITCH (2)
2	0602122281	OIL SWITCH
1	M3310500203	RADIATOR HOSE (UPPER)
1	M3310500303	RADIATOR HOSE (LOWER)
1	0605505070	FUEL CAP
1	0601820671	AUTOMATIC VOLTAGE REGULATOR
1	0601808815	MAIN CIRCUIT BREAKER
1	0601808804	CIRCUIT BREAKER
1	0602103092	PILOT LAMP
2	0601810245	BULB, PILOT LAMP
1	0602011068	CAP, RADIATOR
1	0602122271	UNIT, OIL PRESSURE
1	0602123261	UNIT, WATER TEMPERATURE
1	0602121080	CHARGING AMMETER

#### NOTE

Part number on this Suggested Spare Parts list may supercede/replace the P/N shown in the text pages of this book.

# DCA-150SSJU — GENERATOR ASSY.

GENERATOR ASSY.



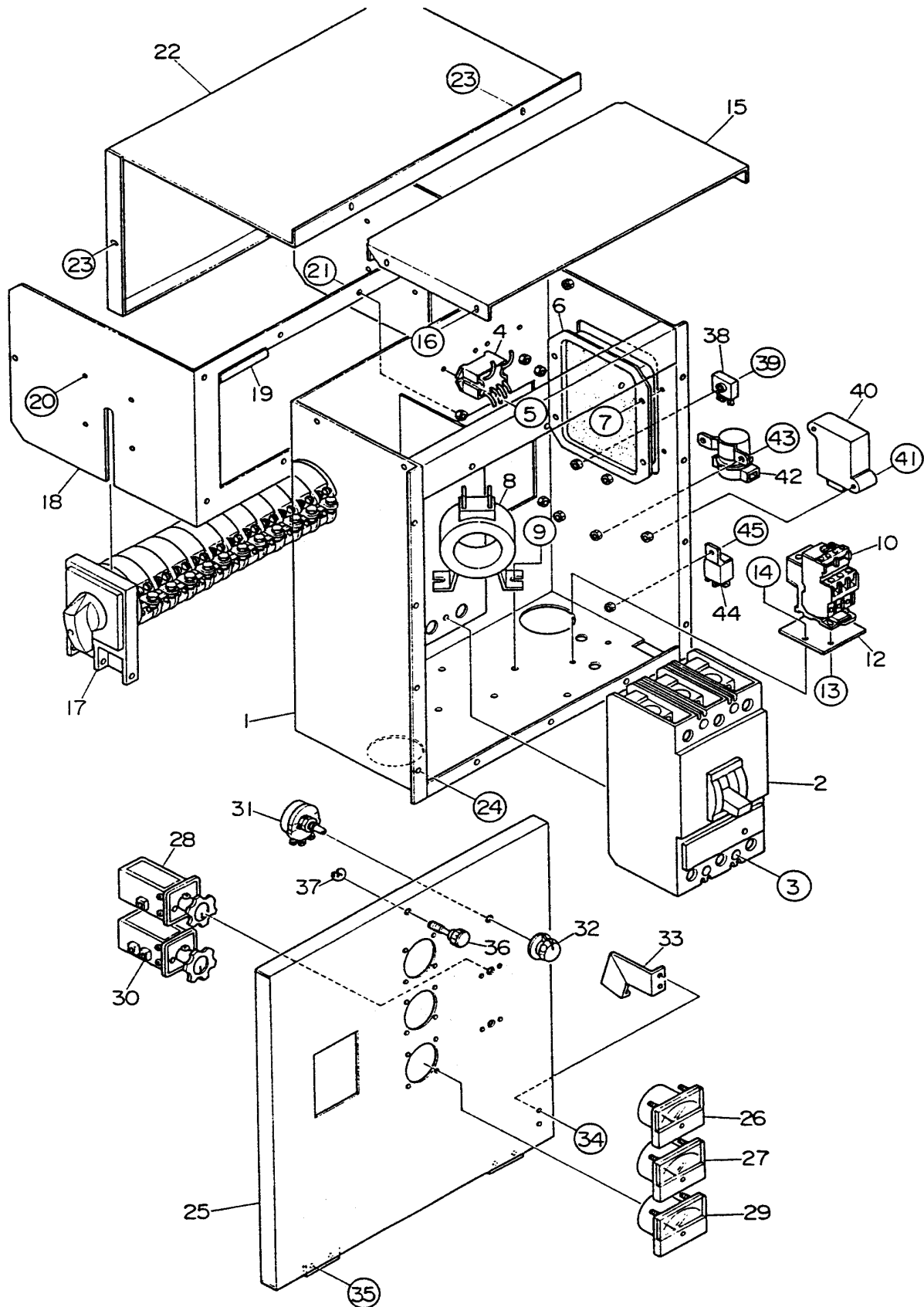
# DCA-150SSJU — GENERATOR ASSY.

## GENERATOR ASSY.

<u>NO.</u>	<u>PART NO.</u>	<u>PART NAME</u>	<u>QTY.</u>	<u>REMARKS</u>
1	C0110000102	ROTOR ASS'Y	1	
*1-1		FIELD ASS'Y	1	
1-2	8131070013	FAN	1	
1-3	8131611914	COUPLING DISK	8	
1-4	8131015003	BALANCING PLATE	1	
1-5	0012112035	HEX. HEAD BOLT	10	
1-6	0042612000	LOCK WASHER	10	
1-7	8101026013	SET PLATE RECTIFIER	1	
1-8	0601821349	RECTIFIER .....	2	PT 3610
1-9	0601822601	SERGE ABSORBER .....	1	ERZ- M14JK621A
1-10	8001020004	INSULATOR WASHER	1	
1-11	8001020504	INSULATOR WASHER	1	
1-12	0010110020	HEX. HEAD BOLT	4	
1-13	0040010000	LOCK WASHER	4	
1-14	0601000209	BALANCING WEIGHT KIT	1	
1-15	0076506312	CERAMIC BEARING .....	1	6312 SN34 DDU C3
2	C0130000003	STATOR ASS'Y	1	
3	0845041804	GROMMET	2	
4	8131315202	END BRACKET	1	
5	8101350013	FIELD ASS'Y. EXCITER	1	
6	0012110060	HEX. HEAD BOLT	4	
7	0042610000	LOCK WASHER	4	
8	031110160	PLAIN WASHER .....	4	REPLACES 0041210000
9	0010112035	HEX. HEAD BOLT	6	
10	0040012000	LOCK WASHER	6	
11	031112230	PLAIN WASHER .....	6	REPLACES 0041212000
12	8131310104	COVER, BEARING	1	
13	8131312204	GASKET BEARING	1	
14	8131331003	COVER, END BRACKET	1	
15	0105050616	HEX. HEAD BOLT .....	10	REPLACES 0017106012
16	8101333003	COVER, END BRACKET	1	
17	0010106030	HEX. HEAD BOLT	2	
18	0040006000	LOCK WASHER	2	
19	952404470	PLAIN WASHER .....	2	REPLACES 0041206000
20	M3163400303	COUPLING RING	1	
21	0013904064	HEX. HEAD BOLT	8	
22	EM923344	LOCK WASHER .....	8	REPLACES 0043604000
23	0070506306	BEARING .....	1	6306ZZ
24	0012810030	HEX. HEAD BOLT	12	
25	0013904032	HEX. HEAD BOLT	12	
26	EM923344	LOCK WASHER .....	12	REPLACES 0043604000
27	C0131300004	COVER, FAN	1	
28	0605000013	RUBBER SUSPENSION	2	
29	0030016000	HEX. NUT	2	
	0040016000	LOCK WASHER	2	
30	020106050	NUT .....	1	REPLACES 0600815000

# DCA-150SSJU —CONTROL BOX ASSY.

CONTROL BOX ASSY.



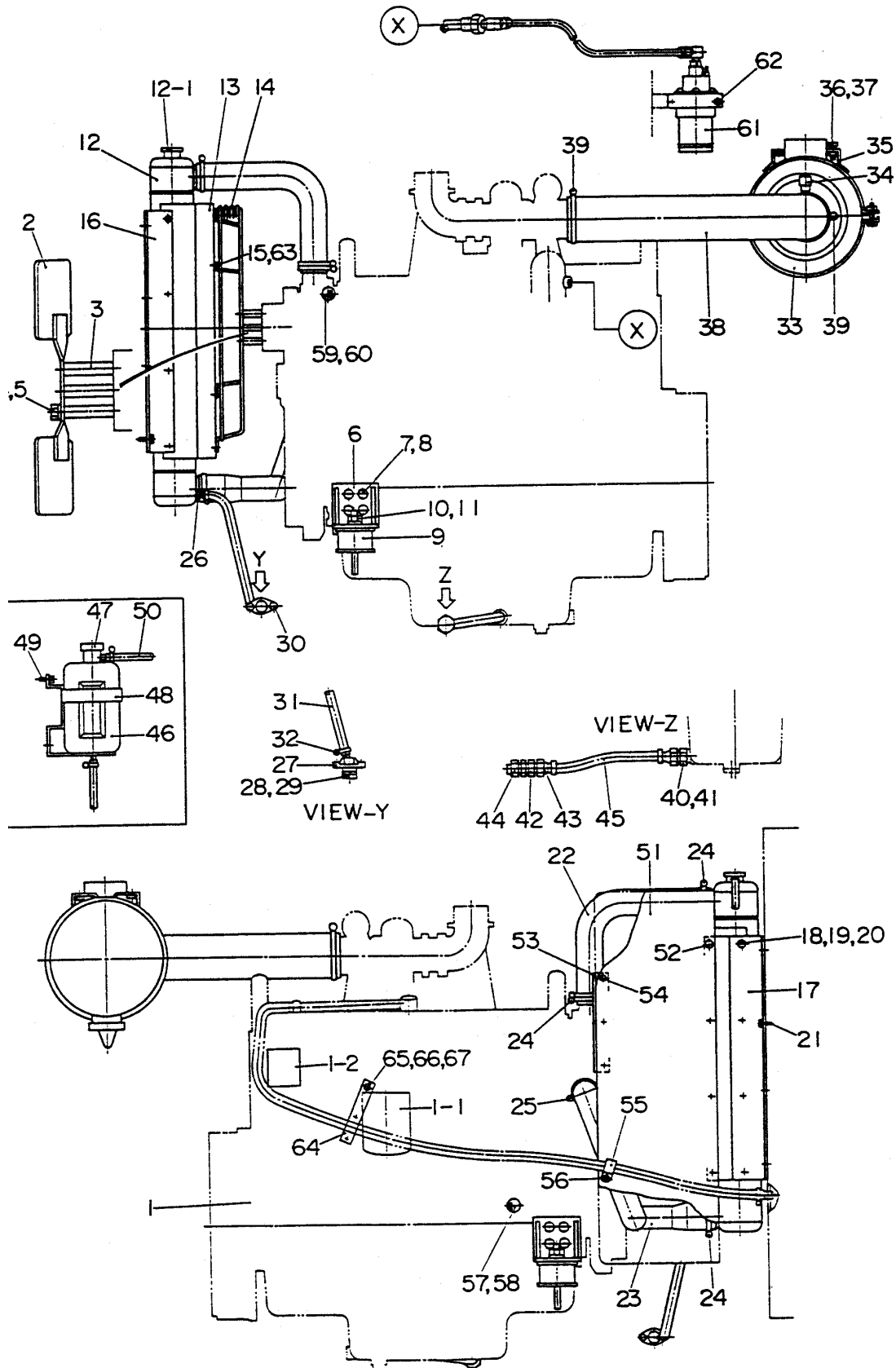
# DCA-150SSJU — CONTROL BOX ASSY.

## CONTROL BOX ASSY.

<u>NO.</u>	<u>PART NO.</u>	<u>PART NAME</u>	<u>QTY.</u>	<u>REMARKS</u>
	M3246700814	WIRE HARNESS, GENERATOR	1	
1	M3213000302	CONTROL BOX	1	
2	0601808815	CIRCUIT BREAKER .....	1	LAF364001021 3P 400A
3	0021006080	MACHINE SCREW	4	
4	0601823863	RELAY UNIT .....	2	MSA9013A
5	0021304015	MACHINE SCREW	4	REPLACES 0027104015
6	0601820671	AUTOMATIC VOLTAGE REGULATOR .....	1	NTA- 5A- 2DB
7	0027105010	MACHINE SCREW	4	
8	0601806127	CURRENT TRANSFORMER .....	3	814- 943 300/5A
9	011808015	MACHINE SCREW	6	REPLACES 0027106015
10	0601820845	OVER CURRENT RELAY .....	1	LR2D1308
11	0601820846	OVER CURRENT RELAY .....	1	LA7D1064
12	M1260600004	FITTING BRACKET	1	
13	0021304015	MACHINE SCREW .....	2	REPLACES 0027104015
	0207004000	HEX. NUT	2	
14	0027104010	MACHINE SCREW	2	
15	M3213500013	CONTROL BOX COVER	1	
16	011106015	HEX. HEAD BOLT .....	4	REPLACES 0016906015
17	M3923100014	SELECTOR SWITCH .....	1	VY- 200
18	M3213600203	SWITCH BRACKET	1	
19	0330000370	EDGES .....	2	REPLACES 0330000370
20	0027104010	MACHINE SCREW	4	
21	011106015	HEX. HEAD BOLT .....	8	REPLACES 0016906015
22	M3213600304	SWITCH COVER	1	
23	011106015	HEX. HEAD BOLT .....	4	REPLACES 0016906015
24	0016906015	HEX. HEAD BOLT	13	
	0040506000	TOOTHED WASHER	1	
25	M3223000303	CONTROL PANEL	1	
26	0601807630	FREQUENCY METER .....	1	264250DJDJ9
27	0601808954	AC AMMETER .....	1	260240LSLS1JBZ
28	0601801040	CHANGE - OVER SWITCH, AMMETER .....	1	SL - 2AS
29	0601806814	AC VOLTMETER .....	1	264230SJSJ9
30	0601801041	CHANGE - OVER SWITCH, VOLTMETER .....	1	SL - 2VS
31	0601840073	RHEOSTAT ( VOLTAGE REGULATOR) .....	1	RA20A2SE102BJ
32	0601840121	KNOB	1	
33	M1223100004	STOPPER	1	
34	0027105015	MACHINE SCREW	2	
35	0027105015	MACHINE SCREW	4	
36	M9220100004	SET SCREW	1	
37	0080200007	SNAP RING	1	
38	0601821370	RECTIFIER .....	1	REPLACES 0601823240; DE 4503
39	0027104020	MACHINE SCREW	1	
40	0602200478	EMERGENCY RELAY .....	1	10701 - 60603
41	0027105040	MACHINE SCREW	2	
42	0602202592	STARTER RELAY .....	1	AT141011
43	011808015	MACHINE SCREW .....	2	REPLACES 0027106015
44	0602202597	RELAY .....	1	AL81719
45	0027105015	MACHINE SCREW	1	

# DCA-150SSJU —ENGINE AND RADIATOR ASSY.

ENGINE & RADIATOR ASSY.



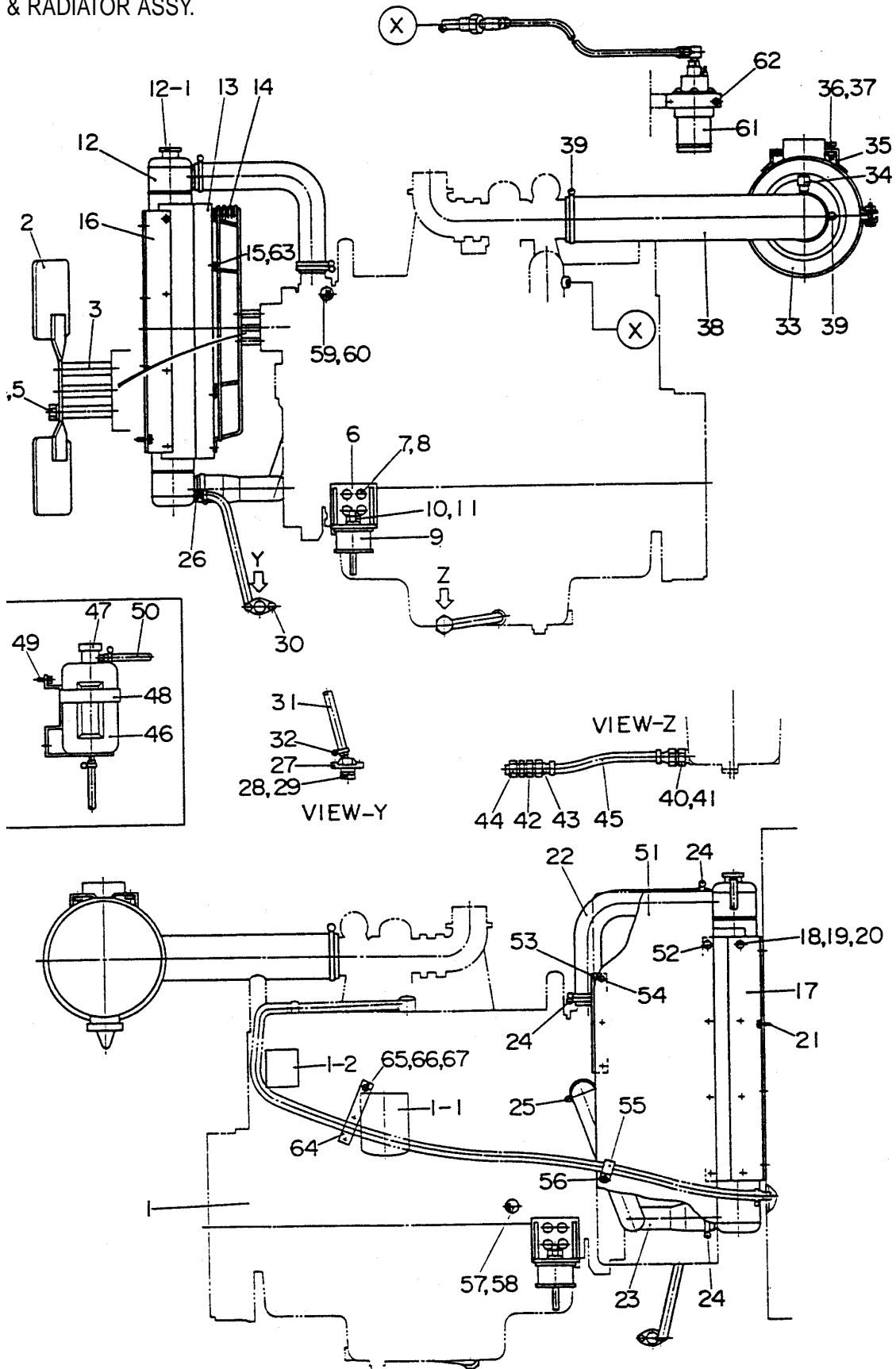
# DCA-150SSJU —ENGINE AND RADIATOR ASSY.

## ENGINE & RADIATOR ASSY.

<u>NO.</u>	<u>PART NO.</u>	<u>PART NAME</u>	<u>QTY.</u>	<u>REMARKS</u>
1	M3923200024	ENGINE .....	1	JOHN DEERE 6081TF
	0602011492	FAN BELT .....	1	2402
1-1	0602041291	ELEMENT, OIL FILTER .....	1	RE57394
1-2	0602042591	ELEMENT, FUEL FILTER .....	1	AR86745
2	0602060012	BLOWER FAN .....	1	REPLACES 0602060002; RE20967
3	0602061001	FAN SPACER .....	1	R128767
4	0013904178	HEX HEAD BOLT	6	
5	0043004000	LOCK WASHER	6	
6	M3303200003	ENGINE FOOT	2	
7	0013907076	HEX HEAD BOLT	8	
8	0043007000	LOCK WASHER	8	
9	0605000011	RUBBER SUSPENSION	2	
10	0030016000	HEX NUT	2	
11	0040016000	LOCK WASHER	2	
12	0602012720	RADIATOR .....	1	RE65161
12-1	0602011068	CAP	1	
13	0602010691	SHROUD .....	1	JOHN DEERE R132912
14	0602010795	FAN COVER .....	1	C281- 004- 4210
15	012210025	HEX HEAD BOLT .....	8	REPLACES 0016910025
16	M3310200604	RADIATOR BRACKET	1	
17	M3310200504	RADIATOR BRACKET	1	
18	0013003019	HEX HEAD BOLT	8	
19	0043003000	LOCK WASHER	8	
20	0043103000	PLAIN WASHER	8	
21	011008020	HEX HEAD BOLT .....	8	REPLACES 0016908020
22	M3310500203	RADIATOR HOSE	1	
23	M3310500303	RADIATOR HOSE	1	
24	0605515148	HOSE BAND	3	
25	0605515147	HOSE BAND	1	
26	0605512194	HOSE JOINT	1	
27	7812014003B	DRAIN JOINT .....	1	REPLACES M2320300103
28	M9200200004	DRAIN BOLT	1	
29	0150000018	O RING	1	
30	011206020	HEX HEAD BOLT .....	2	REPLACES 0016906020
31	0191300730	DRAIN HOSE	1	
32	0605515189	HOSE BAND	2	
33	0602046255	AIR CLEANER .....	1	FWG120063
	0602046379	ELEMENT, AIR CLEANER .....	1	XLP18- 2035
34	0602040650	INDICATOR, AIR CLEANER .....	1	RBX00- 2252

# DCA-150SSJU —ENGINE AND RADIATOR ASSY.

ENGINE & RADIATOR ASSY.



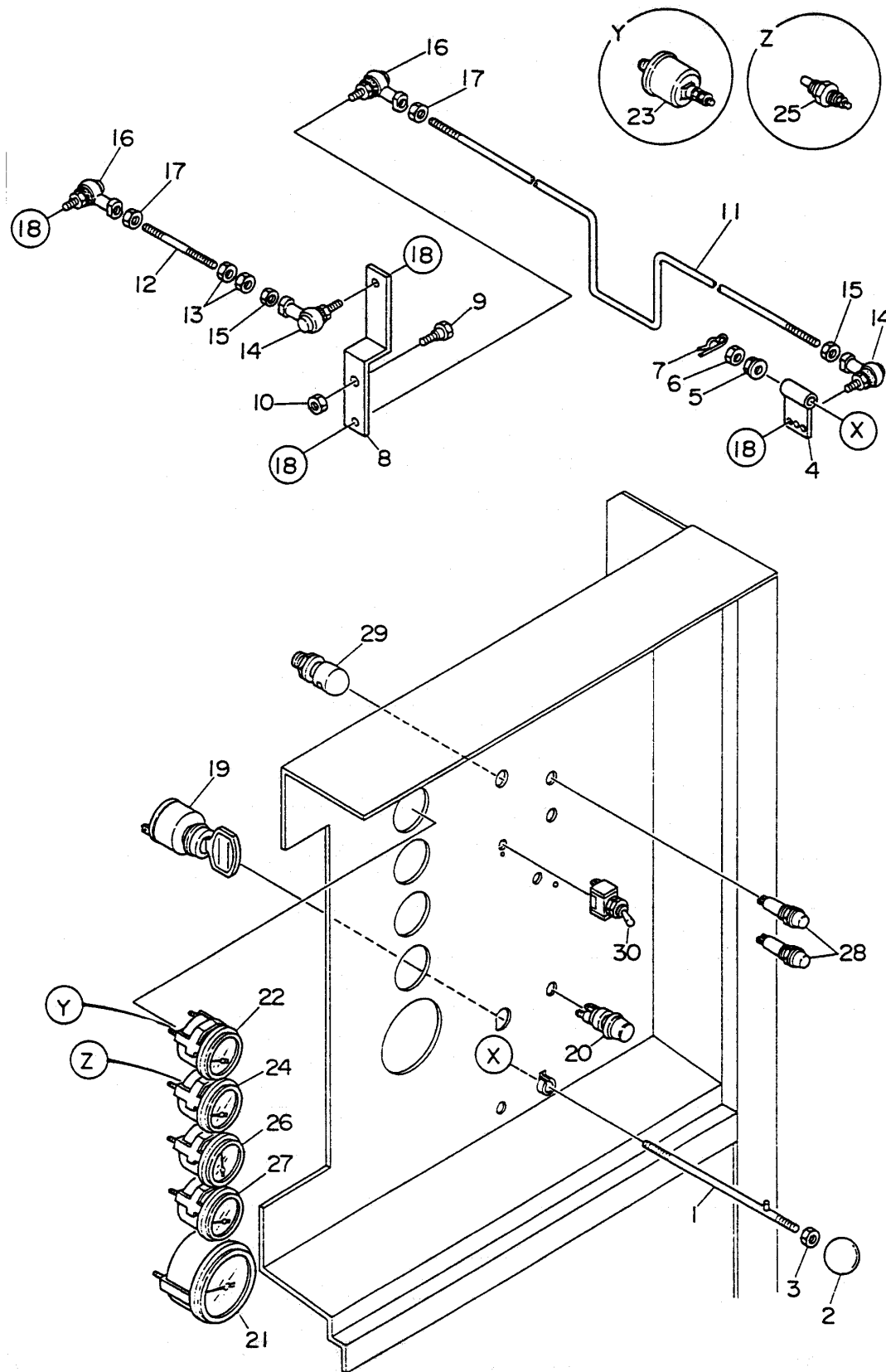
# DCA-150SSJU —ENGINE AND RADIATOR ASSY.

## ENGINE & RADIATOR ASSY.

<u>NO.</u>	<u>PART NO.</u>	<u>PART NAME</u>	<u>QTY.</u>	<u>REMARKS</u>
35	0602040591	BAND, AIR CLEANER	2	
36	011008020	HEX HEAD BOLT .....	4	REPLACES 0016908020
37	020108060	HEX NUT .....	4	REPLACES 0207008000
38	M3373100103	HOSE , AIR CLEANER	1	
39	0605515200	HOSE BAND	2	
40	0602022564	ADAPTER	1	
41	0602021165	O RING	1	
42	0602022562	UNION	1	
43	0602022792	SWIVEL	1	
44	0602021070	CAP	1	
45	0602021572	DRAIN HOSE	1	
46	M9300000203	RESERVE TANK	1	
47	0802010900	CAP, RESERVE TANK .....	1	REPLACES 0602010900
48	M3316100104	BRACKET, RESERVE TANK	1	
49	011008020	HEX HEAD BOLT .....	2	REPLACES 0016908020
50	0193601200	HOSE	1	
51	M3313100104	RADIATOR COVER	1	
	M3493600004	ACOUSTIC SHEET	1	
52	011008020	HEX HEAD BOLT .....	4	REPLACES 0016908020
53	M3483400104	ALTERNATOR COVER	1	
54	011008020	HEX HEAD BOLT .....	3	REPLACES 0016908020
55	0602220911	CLAMP	1	
56	011008020	HEX HEAD BOLT .....	1	REPLACES 0016908020
57	0602122281	OIL SWITCH .....	1	17189- 39011
58	M9200100704	ADAPTER	1	
59	0602123282	WATER SWITCH .....	1	15181- 83041
60	M9200100404	ADAPTER	1	
61	0602014298	ETHER KIT .....	1	AR68492
62	011106015	HEX HEAD BOLT .....	2	REPLACES 0016906015
63	0041216000	PLAIN WASHER	8	
64	M3326200004	HOSE BRACKET	1	
65	0013003019	HEX HEAD BOLT	1	
66	0043003000	LOCK WASHER	1	
67	0043103000	PLAIN WASHER	1	

# DCA-150SSJU —ENGINE OPERATING PANEL ASSY.

ENGINE OPERATING PANEL ASSY.



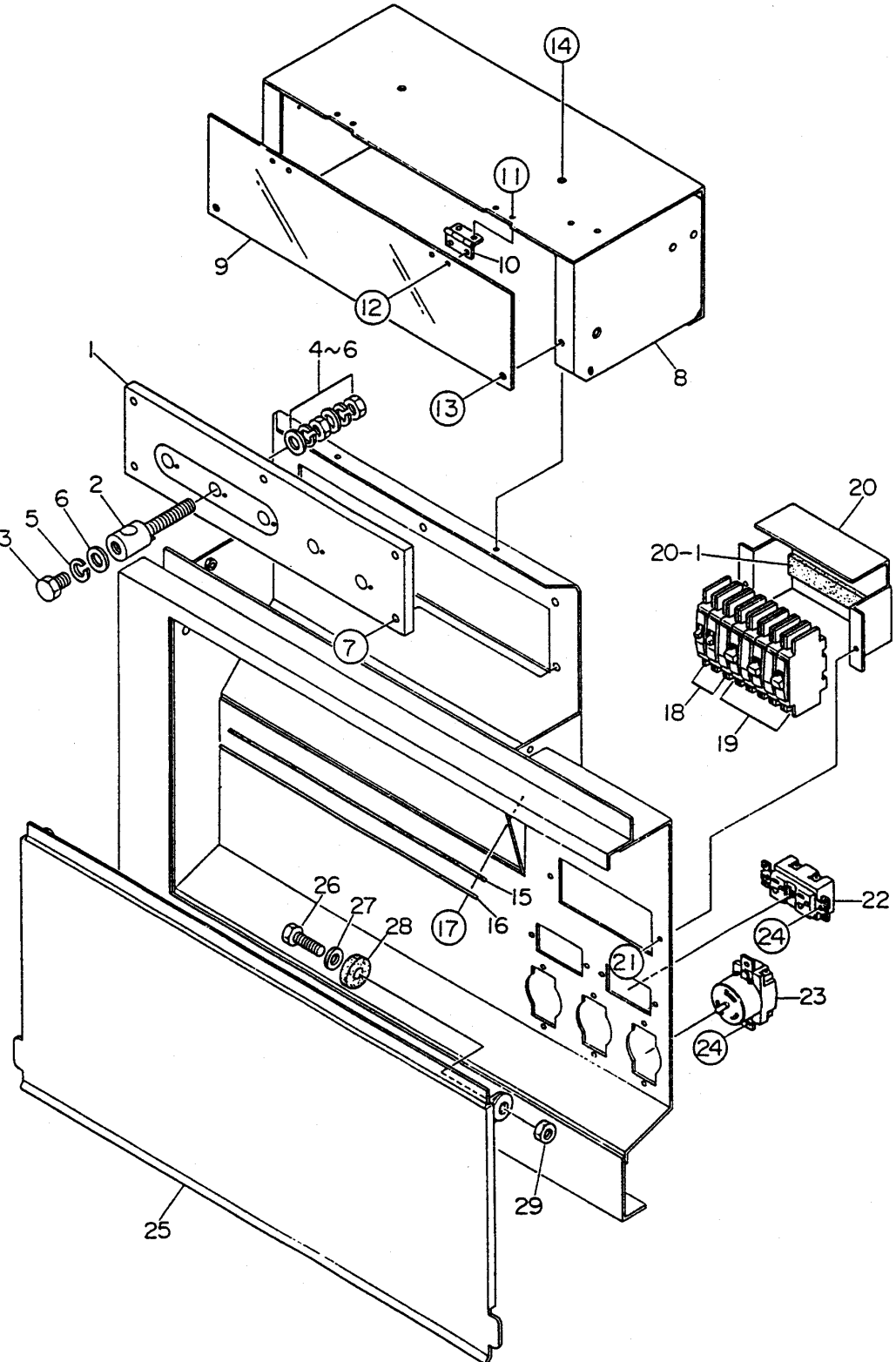
# DCA-150SSJU —ENGINE OPERATING PANEL ASSY.

## ENGINE OPERATING PANEL ASSY.

<u>NO.</u>	<u>PART NO.</u>	<u>PART NAME</u>	<u>QTY.</u>	<u>REMARKS</u>
	M3357200112	WIRE HARNESS, ENGINE	1	
1	M1354300304	SLIDE LEVER	1	
2	0601840190	KNOB .....	1	REPLACES M9320000004
3	020108060	HEX NUT .....	1	REPLACES 0036003000
4	M1354200004	BRACKET	1	
5	020108060	HEX NUT .....	1	REPLACES 0207008000
6	020108060	HEX NUT .....	1	REPLACES 0030008000
7	0605010550	SNAP PIN	1	
8	M3354600004	GOVERNOR LEVER	1	
9	M3354600104	GOVERNOR BOLT	1	
10	0036203000	HEX NUT	1	
11	M3354300204	GOVERNOR ROD	1	
12	M3354300304	GOVERNOR ROD	1	
13	020108060	HEX NUT .....	2	REPLACES 0030008000
14	0602180106	BALL JOINT	2	
15	020108060	HEX NUT .....	2	REPLACES 0030008000
16	0602180107	BALL JOINT	2	
17	020108060	HEX NUT .....	2	REPLACES 0036508000
18	0207006000	HEX NUT	4	
	952404470	PLAIN WASHER .....	4	REPLACES 0041206000
19	0602100056	STARTER SWITCH .....	1	AR58126
	0602100028	SET NUT .....	1	R44342
	0602100029	SET WASHER .....	1	A4827R
20	0601831594	COLD STARTING BUTTON .....	1	R39554
	0601831584	CAP .....	1	T55585
21	0602120096	TACHOMETER .....	1	103678
22	0602122093	OIL PRESSURE GAUGE .....	1	100174
23	0602122272	UNIT, OIL PRESSURE .....	1	REPLACES 0602122271; 105965
24	0602123092	WATER TEMPERATURE GAUGE .....	1	100182
25	0602123261	UNIT, WATER TEMPERATURE .....	1	02025- 00
26	0602121080	CHARGING AMMETER .....	1	100158
27	0602125090	FUEL GAUGE .....	1	100176
28	0602103092	ALARM LAMP .....	2	PL- 05
	0601810245	BULB .....	2	E- 10 T- 10 DC18V
29	0601810141	PANEL LIGHT .....	1	98268- 00370
30	0601831330	SWITCH, PANEL LIGHT .....	1	90- 0001

# DCA-150SSJU —OUTPUTTERMINAL ASSY.

OUTPUT TERMINAL ASSY.



# DCA-150SSJU —OUTPUT TERMINAL ASSY.

## OUTPUT TERMINAL ASSY.

<u>NO.</u>	<u>PART NO.</u>	<u>PART NAME</u>	<u>QTY.</u>	<u>REMARKS</u>
1	M3230700003	TERMINAL PANEL	1	
2	M9220100304	OUTPUT TERMINAL BOLT	5	
3	0801830804	TIE BOLT .....	5	REPLACES M9220100404
4	0039316000	HEX NUT	10	
5	0040016000	LOCK WASHER	15	
6	0041416000	PLAIN WASHER	20	
7	0012108035	HEX HEAD BOLT .....	5	REPLACES 0016908035
8	M3236100303	TERMINAL COVER	1	
9	M3236100104	OUTPUT WINDOW	1	
10	0605010040	HINGE	2	
11	0027103010	MACHINE SCREW	4	
	0207003000	HEX NUT .....	4	REPLACES 0030003000
	58413	PLAIN WASHER .....	4	REPLACES 0041203000
12	0027103010	MACHINE SCREW	4	
	0207003000	HEX NUT .....	4	REPLACES 0030003000
13	0112206020	HEX HEAD BOLT .....	2	REPLACES 0016906020
14	011106015	HEX HEAD BOLT .....	4	REPLACES 0016906015
15	M3236400004	CABLE OUTLET COVER	1	
16	M3236300004	SUPPORTER, CABLE OUTLET COVER	1	
17	011206020	HEX HEAD BOLT .....	6	REPLACES 0016906020
18	0601808803	CIRCUIT BREAKER .....	2	QOU 120B 1P 20A
19	0601808804	CIRCUIT BREAKER .....	3	QOU 250B 2P 50A
20	M1260700304	BREAKER FITTING COVER	1	
20-1	0222100150	CUSHION RUBBER	1	
21	011206020	HEX HEAD BOLT .....	2	REPLACES 0016906020
22	0601812597	RECEPTACLE .....	2	REPLACES 0601812598; GF530EM 125V 20A X 2
23	0601811034	RECEPTACLE .....	3	REPLACES 0601812538; CS6369 250V 50A
24	0021304015	MACHINE SCREW .....	10	REPLACES 0027104015
	0030004000	HEX NUT .....	10	REPLACES 0207004000
25	M3236100213	TERMINAL COVER	1	
26	012212045	HEX HEAD BOLT .....	2	REPLACES 0010112045
27	031112230	PLAIN WASHER .....	2	REPLACES 0041212000
28	M9310200004	STAY RUBBER	2	
29	0030012000	HEX NUT	2	

ADD THE FOLLOWING DIGITS AFTER THE PART NUMBER  
WHEN ORDERING ANY PAINTED PANEL TO INDICATE

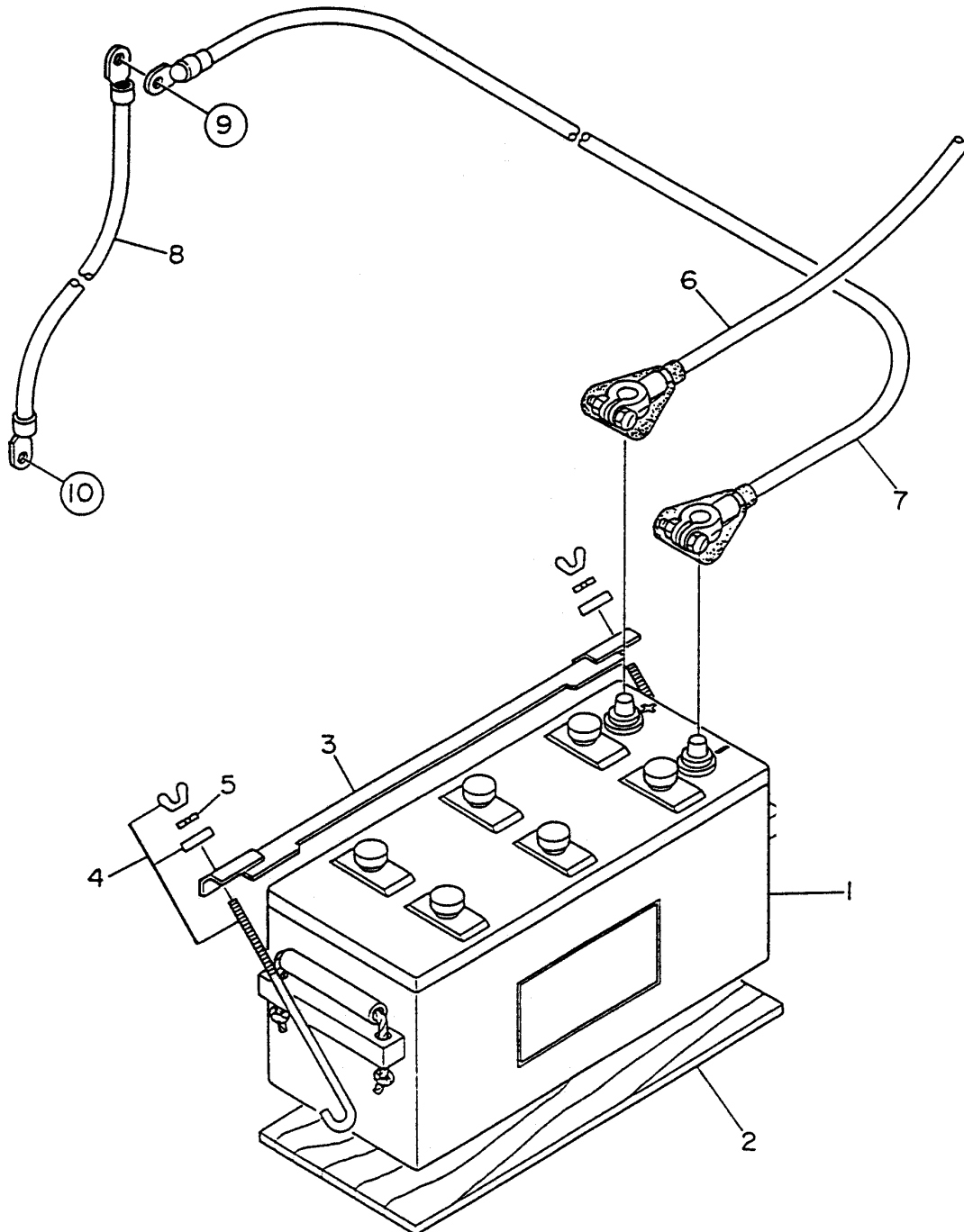
COLOR OF UNIT:

1-ORANGE	5-BLACK
2-WHITE	6-CATERPILLAR YELLOW
3-SPECTRUM GRAY	7-CATO GOLD
4-SUNBELT GREEN	8-RED

THE SERIAL NUMBER MAY BE REQUIRED.

# DCA-150SSJU —BATTERY ASSY.

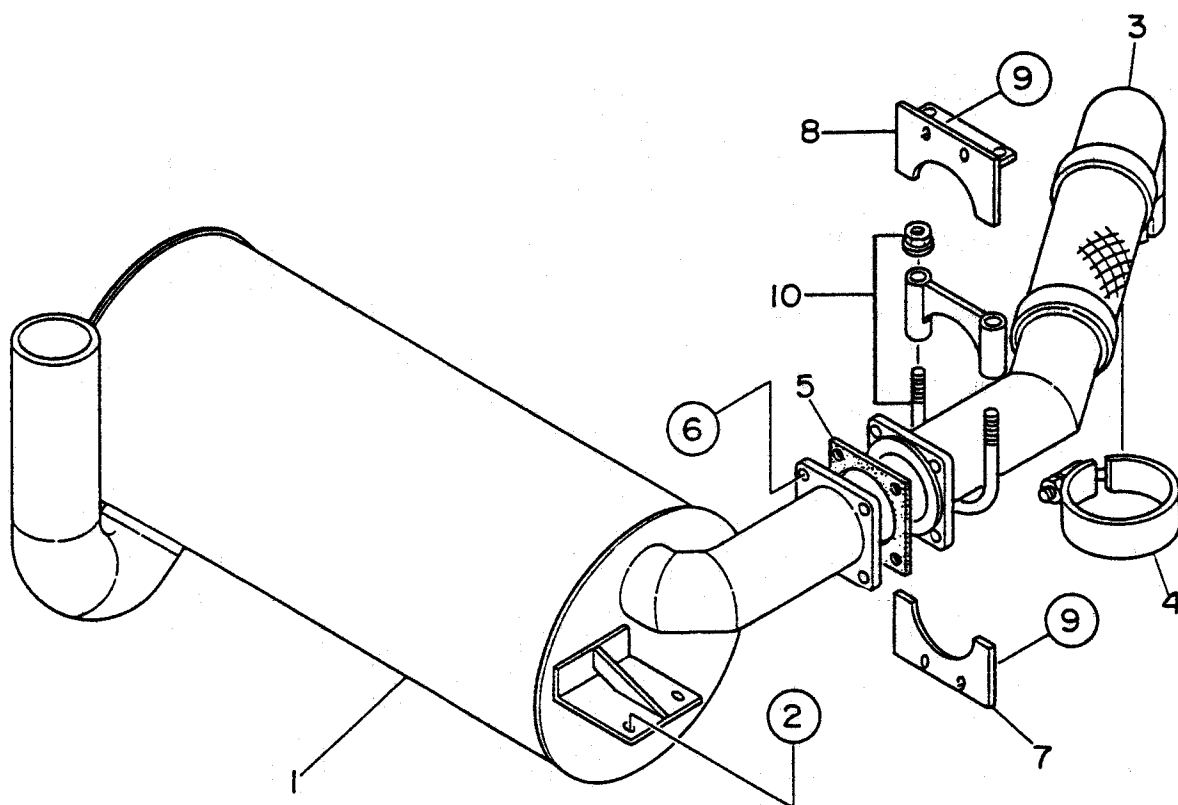
BATTERY ASSY.



BATTERY ASSY.

<u>NO.</u>	<u>PART NO.</u>	<u>PART NAME</u>	<u>QTY.</u>	<u>REMARKS</u>
1	0602220196	BATTERY .....	1	4D- 2
2	M9310500404	BATTERY SHEET	1	
3	M9103000504	BATTERY BAND	1	
4	0602220921	BATTERY BOLT SET	2	
5	0040006000	LOCK WASHER	2	
6	M3346900204	BATTERY CABLE	1	
	M3346900214	BATTERY CABLE	1	
7	M3346900104	BATTERY CABLE .....	1	REPLACES M3346900304
8		CABLE	1	
9	0013007025	HEX HEAD BOLT	1	
	0043007000	LOCK WASHER	1	
	0043107000	PLAIN WASHER	1	
	0040516000	TOOTHED WASHER	1	
10	012210020	HEX HEAD BOLT .....	1	REPLACES 0017110020
	0040510000	TOOTHED WASHER	1	

MUFFLER ASSY.



## MUFFLER ASSY.

<u>NO.</u>	<u>PART NO.</u>	<u>PART NAME</u>	<u>QTY.</u>	<u>REMARKS</u>
1	M3330100202	MUFFLER	1	
	0602300168	MUFFLER	1	
2	012210025	HEX HEAD BOLT .....	4	REPLACES 0016910025
3	M3333000503	EXHAUST PIPE	1	
4	0602325066	CLAMP	1	
5	M3333200104	GASKET	1	
6	0017110050	HEX HEAD BOLT	4	
7	M3330400804	COVER	1	
8	M3330400903	BRACKET	1	
9	011008020	HEX HEAD BOLT .....	4	REPLACES 0016908020
10	0602326062	U BOLT SET	1	



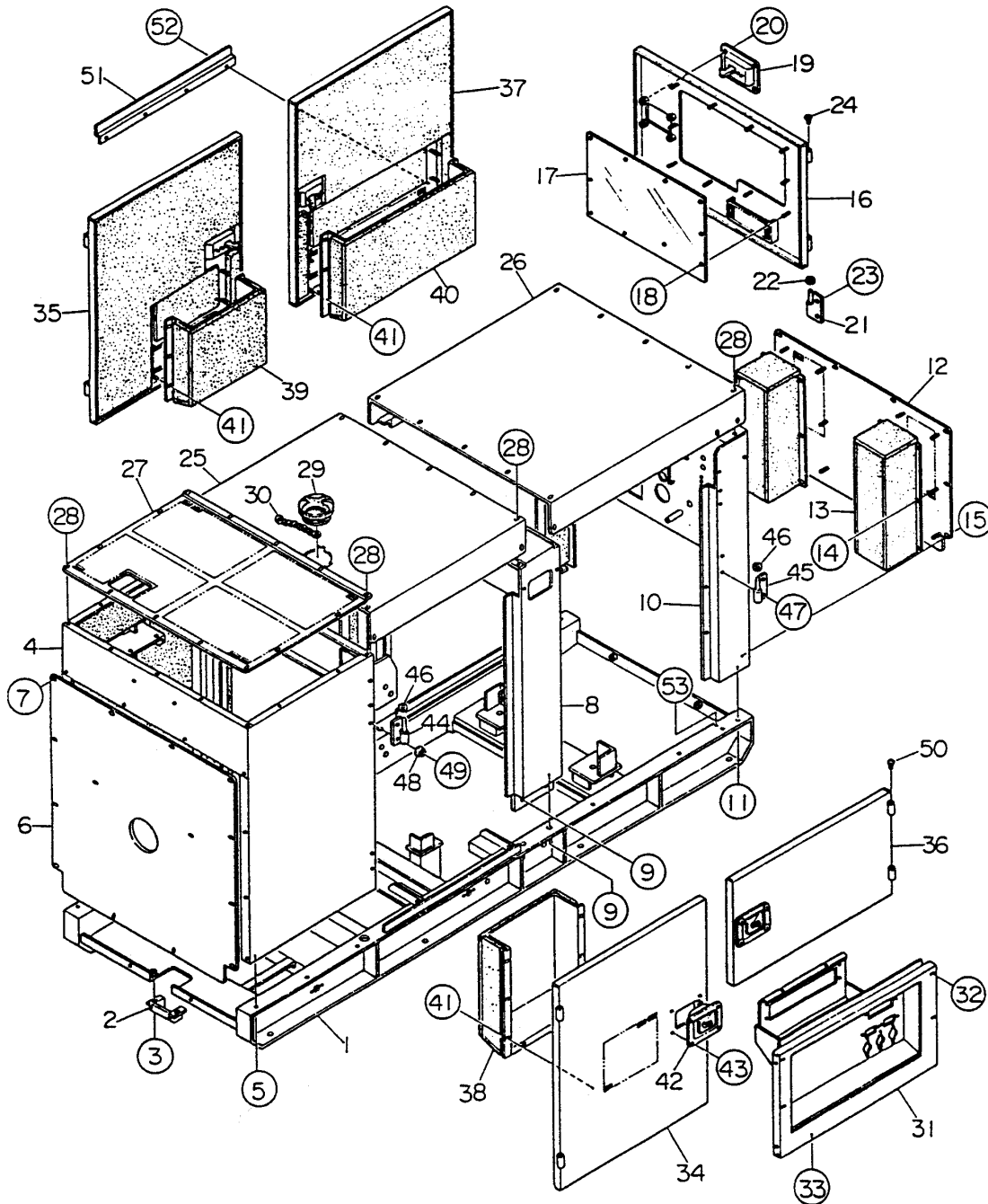
# DCA-150SSJU —FUEL TANK ASSY.

## FUEL TANK ASSY.

<u>NO.</u>	<u>PART NO.</u>	<u>PART NAME</u>	<u>QTY.</u>	<u>REMARKS</u>
1	M3363000402	FUEL TANK	1	
1-1	0605505070	CAP, FUEL TANK	1	
2	M3363200204	TANK BAND	2	
3	M9310500104	SUPPORTER SHEET	4	
4	011008020	HEX HEAD BOLT .....	2	REPLACES 0016908020
5	0207308000	HEX NUT	2	
6	0222100660	RUBBER SHEET	2	
7	1502025103C	DRAIN JOINT .....	1	REPLACES M9200000003
8	M9200200004	DRAIN BOLT	1	
9	0150000018	O RING	1	
10	011206020	HEX HEAD BOLT .....	2	REPLACES 0016906020
11	M1363400104	DRAIN HOSE	1	
12	0605515198	HOSE BAND	2	
13	0602042420	FUEL FILTER .....	1	PTG15P
14	0602022793	HOSE JOINT .....	1	REPLACES 0605512195
15	0602042601	LEAK - OFF LINE .....	1	67050
16	0191300100	SUCTION HOSE	1	
17	0191300900	SUCTION HOSE	1	
18	0191302400	RETURN HOSE	1	
19	0605515109	HOSE BAND	6	

# DCA-150SSJU —ENCLOSURE ASSY.

## ENCLOSURE ASSY.



ADD THE FOLLOWING DIGITS AFTER THE PART NUMBER  
WHEN ORDERING ANY PAINTED PANEL TO INDICATE  
COLOR OF UNIT:

- |                 |                      |
|-----------------|----------------------|
| 1-ORANGE        | 5-BLACK              |
| 2-WHITE         | 6-CATERPILLAR YELLOW |
| 3-SPECTRUM GRAY | 7-CATO GOLD          |
| 4-SUNBELT GREEN | 8-RED                |

THE SERIAL NUMBER MAY BE REQUIRED.

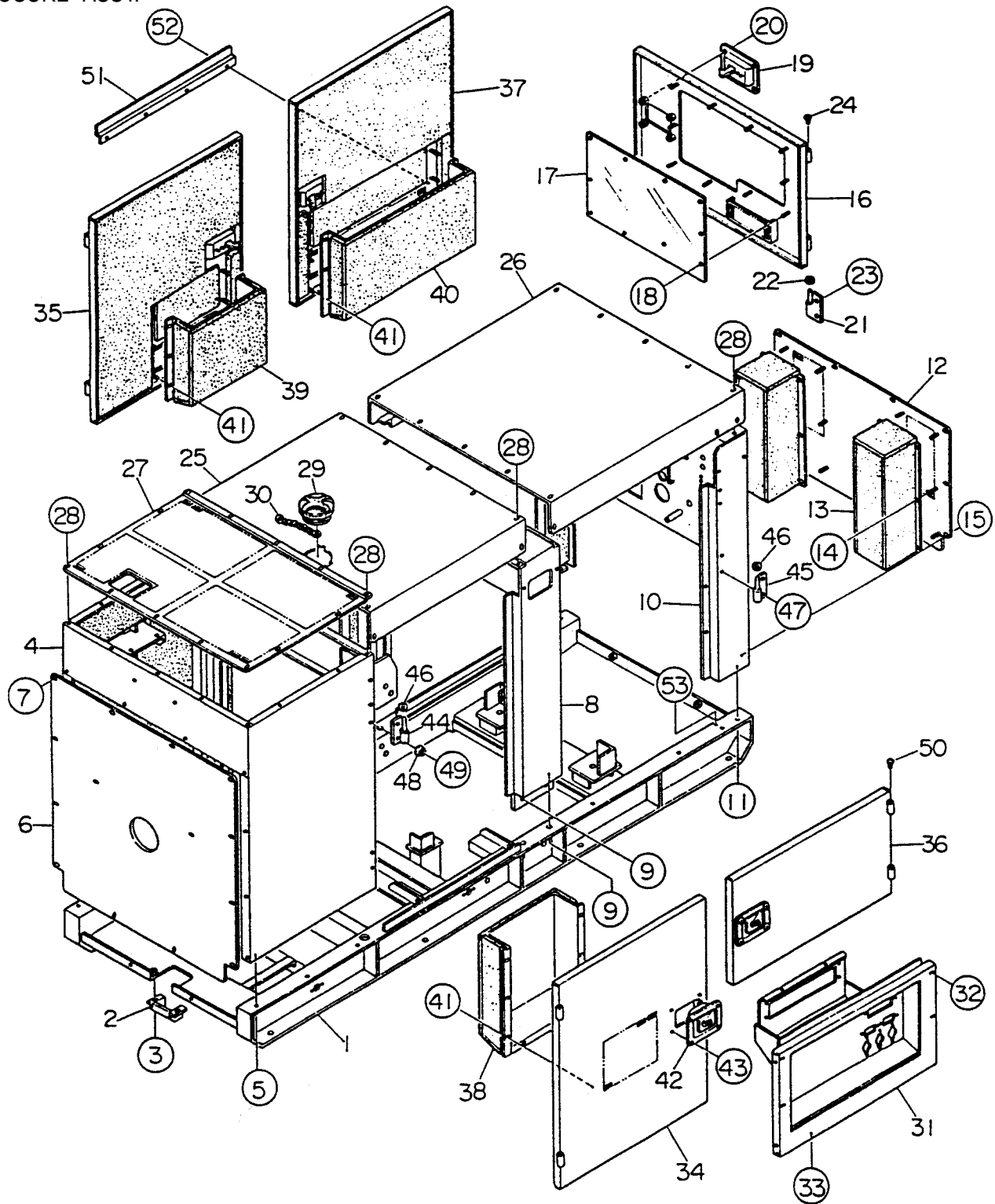
# DCA-150SSJU —ENCLOSURE ASSY.

## ENCLOSURE ASSY.

<u>NO.</u>	<u>PART NO.</u>	<u>PART NAME</u>	<u>QTY.</u>	<u>REMARKS</u>
1	M3413000402	BASE	1	
2	M1413400004	UNDER COVER	1	
3	011008020	HEX HEAD BOLT .....	2	REPLACES 0016908020
4	M3423000502	FRONT FRAME	1	
	M3493101703	ACOUSTIC SHEET	1	
5	012210025	HEX HEAD BOLT .....	6	REPLACES 0016910025
6	M3423200304	COVER, FRONT FRAME	1	
	M3493103104	ACOUSTIC SHEET	1	
7	011008020	HEX HEAD BOLT .....	16	REPLACES 0016908020
8	M3433000312	CENTER FRAME	1	
	M3493200304	ACOUSTIC SHEET	1	
9	0010114045	HEX HEAD BOLT	12	
	0010114040	HEX HEAD BOLT	12	
	020114110	HEX NUT .....	12	REPLACES 0030014000
	030214350	LOCK WASHER .....	24	REPLACES 0040014000
	031114260	PLAIN WASHER .....	24	REPLACES 0041214000
10	M3443000402	REAR FRAME	1	
	M3493301504	ACOUSTIC SHEET	1	
11	012210025	HEX HEAD BOLT .....	4	REPLACES 0016910025
12	M3443300603	REAR COVER	1	
	M3493302204	ACOUSTIC SHEET	2	
13	M3443300503	DUCT, REAR COVER	2	
	M3493301804	ACOUSTIC SHEET	1	
14	0207006000	HEX NUT	12	
15	011008020	HEX HEAD BOLT .....	12	REPLACES 0016908020
16	M3443200213	REAR DOOR .....	1	REPLACES M3443200203
17	M3443600104	WINDOW PLATE	1	
18	020106050	HEX NUT .....	10	REPLACES 0207306000
	952404470	PLAIN WASHER .....	10	REPLACES 0041206000
19	B9114000002	DOOR HANDLE ASSY .....	1	REPLACES M9113000002
20	0021806015	MACHINE SCREW .....	4	REPLACES 0021806015
	020106050	HEX NUT .....	4	REPLACES 0030006000
21	M9110100204	HINGE	2	
22	M9116100004	WASHER	2	
23	011008020	HEX HEAD BOLT .....	3	REPLACES 0016908020
24	0845031504	BLIND PLUG .....	2	REPLACES M9310000004
25	M3463100303	ROOF PANEL	1	
	M3493501203	ACOUSTIC SHEET	1	
26	M3463200202	ROOF PANEL	1	
	M3493501603	ACOUSTIC SHEET	1	
27	M3463500204	OVER COVER, FRONT FRAME	1	
28	011008020	HEX HEAD BOLT .....	39	REPLACES 0016908020

# DCA-150SSJU — ENCLOSURE ASSY.

## ENCLOSURE ASSY.



# DCA-150SSJU —ENCLOSURE ASSY.

## ENCLOSURE ASSY.

<u>NO.</u>	<u>PART NO.</u>	<u>PART NAME</u>	<u>QTY.</u>	<u>REMARKS</u>
29	1625165103	BONNET CAP .....	1	REPLACES M9310000103
30	1625165204	CHAIN ASS'Y .....	1	REPLACES M1483600204
31	M3453200312	SPLASHER PANEL	1	
	M3493405504	ACOUSTIC SHEET .....	1	REPLACES M3493405514
32	011208060	HEX HEAD BOLT .....	4	REPLACES 0016908055
33	012210025	HEX HEAD BOLT .....	2	REPLACES 0016910025
34	M3453001103	SIDE DOOR	1	
	M3493403804	ACOUSTIC SHEET	1	
35	M3453001003	SIDE DOOR	1	
	M3493404404	ACOUSTIC SHEET	1	
36	M3453000903	SIDE DOOR	1	
	M3493405204	ACOUSTIC SHEET	1	
37	M3453000803	SIDE DOOR	1	
	M3493405304	ACOUSTIC SHEET	1	
38	M3453000803	DUCT	1	
	M3493406303	ACOUSTIC SHEET	1	
39	M3453300603	DUCT	1	
	M3493404804	ACOUSTIC SHEET	1	
40	M3453300203	DUCT	1	
	M3493407003	ACOUSTIC SHEET	1	
41	0207006000	HEX NUT	25	
42	B9114000002	DOOR HANDLE ASSY .....	4	REPLACES M9113000002
43	0027106016	MACHINE SCREW .....	16	REPLACES 0021806015
	020106050	HEX NUT .....	16	REPLACES 0030006000
44	M9110100204	HINGE	4	
45	M9110100304	HINGE	4	
46	M9116100004	WASHER	8	
47	011008020	HEX HEAD BOLT .....	9	REPLACES 0016908020
48	0601850097	DOOR STOPPER	8	
49	0027208025	MACHINE SCREW	8	
50	0845031504	BLIND PLUG .....	8	REPLACES M9310000004
51	M3453700004	DOOR BRACKET	1	
52	011106015	HEX HEAD BOLT .....	4	REPLACES 0016906015
53	011008020	HEX HEAD BOLT .....	1	REPLACES 0016908020
	0040508000	TOOTHED WASHER	1	

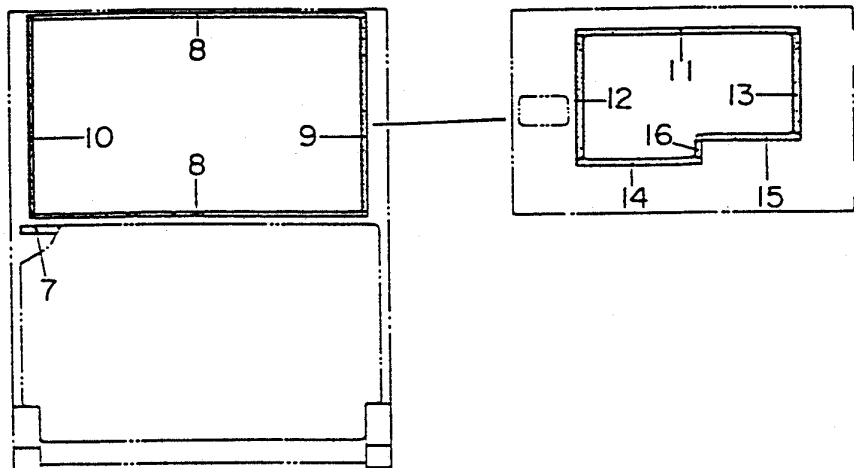
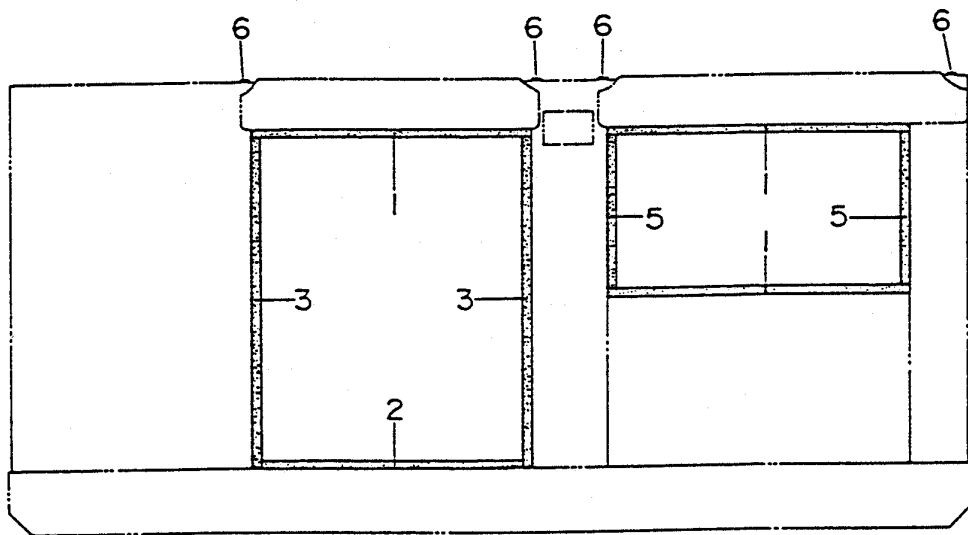
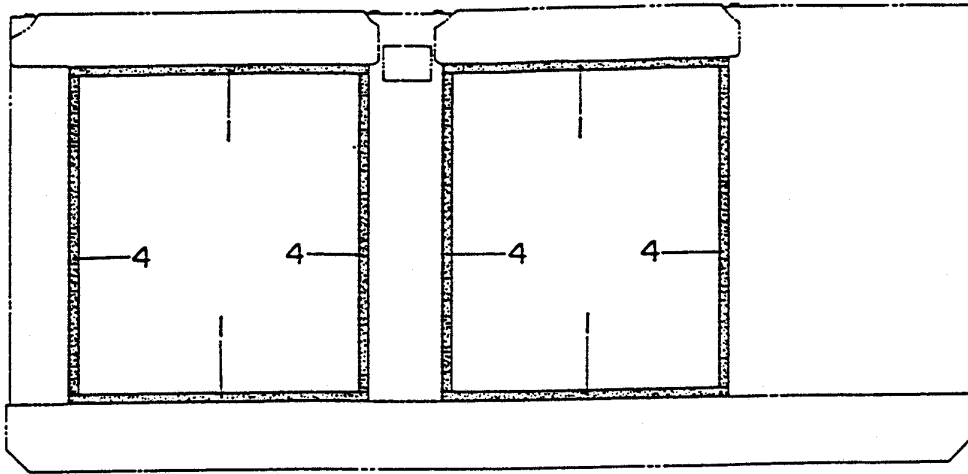
ADD THE FOLLOWING DIGITS AFTER THE PART NUMBER  
WHEN ORDERING ANY PAINTED PANEL TO INDICATE  
COLOR OF UNIT:

1-ORANGE	5 -BLACK
2-WHITE	6 -CATERPILLAR YELLOW
3 -SPECTRUM GRAY	7 -CATO GOLD
4 -SUNBELT GREEN	8 -RED

THE SERIAL NUMBER MAY BE REQUIRED.

# DCA-150SSJU —RUBBER SEAL ASSY.

RUBBER SEALS ASSY.



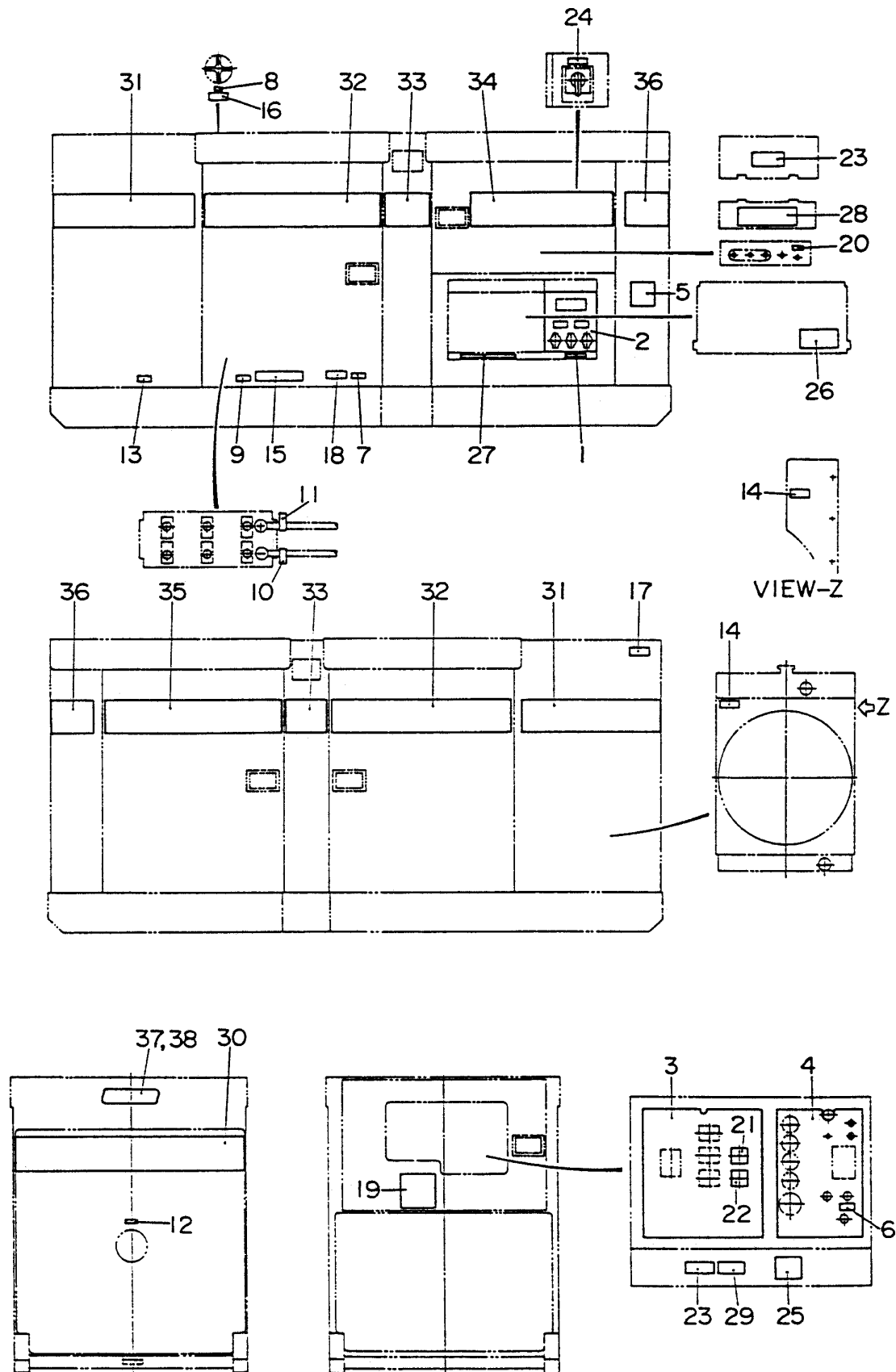
# DCA-150SSJU —RUBBER SEAL ASSY.

## RUBBER SEALS ASSY.

<u>NO.</u>	<u>PART NO.</u>	<u>PART NAME</u>	<u>QTY.</u>	<u>REMARKS</u>
1	0228900955	RUBBER SEAL	7	
2	0229200810	RUBBER SEAL	1	
3	0228901120	RUBBER SEAL	2	
4	0228901090	RUBBER SEAL	4	
5	0228900520	RUBBER SEAL	2	
6	0229201200	RUBBER SEAL	4	
7	0229201140	RUBBER SEAL	1	
8	0228801070	RUBBER SEAL	2	
9	0228800680	RUBBER SEAL	1	
10	0228800640	RUBBER SEAL	1	
11	0228100665	RUBBER SEAL	1	
12	0228100370	RUBBER SEAL	1	
13	0228100300	RUBBER SEAL	1	
14	0228100365	RUBBER SEAL	1	
15	0228100280	RUBBER SEAL	1	
16	0228100070	RUBBER SEAL	1	

# DCA-150SSJU — OPERATION AND SAFETY DECAL ASSY.

NAME PLATE ASSY.



# DCA-150SSJU — OPERATION AND SAFETY DECAL ASSY.

## NAME PLATE ASSY.

<u>NO.</u>	<u>PART NO.</u>	<u>PART NAME</u>	<u>QTY.</u>	<u>REMARKS</u>
1	M1550000204	DECAL : NOTE .....	1 .....	M15000020
2	M1550000703	DECAL : AUXILIARY OUTPUT .....	1 .....	M15000070
3	M3550000602	DECAL : GENERATOR CONTROL .....	1 .....	M35000060
4	M3550000702	DECAL : ENGINE OPERATING .....	1 .....	M35000070
5	M3550000804	DECAL : NOTE .....	1 .....	M35000080
6	M3550000904	DECAL : FOR COLD STARTING .....	1 .....	M35000090
7	M9500000004	DECAL : OIL DRAIN PLUG .....	1 .....	M90000000
8	M9500100004	DECAL : WATER .....	1 .....	M90010000
9	M9500100104	DECAL : WATER DRAIN PLUG .....	1 .....	M90010010
10	M9500300004	DECAL : - .....	1 .....	M90030000
11	M9500300104	DECAL : + .....	1 .....	M90030010
12	M9500500004	DECAL : DIESEL FUEL .....	1 .....	M90050000
13	M9500500104	DECAL : FUEL DRAIN PLUG .....	1 .....	M90050010
14	M9503000004	DECAL : WARNING .....	2 .....	M90300000
15	M9503000103	DECAL : WATER - OIL CHECK .....	1 .....	M90300010
16	M9503100004	DECAL : WARNING .....	1 .....	M90310000
17	M9503200004	DECAL : WARNING .....	1 .....	M90320000
18	M9510100004	DECAL : CAUTION .....	1 .....	M91010000
19	M9510200002	DECAL : MQ .....	1 .....	M91020000
20	M9520000004	DECAL : GROUND .....	1 .....	M92000000
21	M9520000104	DECAL : AMMETER CHANGE - OVER SWITCH .....	1 .....	M92000010
22	M9520000204	DECAL : VOLTMETER CHANGE - OVER SWITCH ...	1 .....	M92000020
23	M9520100004	DECAL : WARNING .....	2 .....	M92010000
24	M9520100204	DECAL : CAUTION .....	1 .....	M92010020A
25	M9520100304	DECAL : SAFETY INSTRUCTIONS .....	1 .....	M92010030
26	M9520100404	DECAL : DANGER .....	1 .....	M92010040
27	M9520100503	DECAL : WARNING .....	1 .....	M92010050
28	M9520200003	DECAL : CONNECTIONS OF OUTPUT CABLE .....	1 .....	M92020000
29	M9520200104	DECAL : OVER CURRENT RELAY .....	1 .....	M92020010
30	M3560100903	STRIPE : WHISPERWATT	1	
31	M3560101003	STRIPE : MQ POWER	2	
32	M3560101103	STRIPE	2	
33	M3560101304	STRIPE	2	
34	M3560101203	STRIPE : 150	1	
35	M3560101403	STRIPE : 150	1	
36	M3560101504	STRIPE	2	
37	0600500090	EMBLEM	1	
38	0021106015	MACHINE SCREW	2	

**PAYMENT TERMS**

Terms of payment for parts are net 10 days.

**FREIGHT POLICY**

All parts orders will be shipped collect or prepaid with the charges added to the invoice. All shipments are F.O.B. point of origin. Multiquip's responsibility ceases when a signed manifest has been obtained from the carrier, and any claim for shortage or damage must be settled between the consignee and the carrier.

**MINIMUM ORDER**

The minimum charge for orders from Multiquip is \$15.00 net. Customers will be asked for instructions regarding handling of orders not meeting this requirement.

**RETURNED GOODS POLICY**

Return shipments will be accepted and credit will be allowed, subject to the following provisions:

1. A Returned Material Authorization must be approved by Multiquip prior to shipment.
2. To obtain a Return Material Authorization, a list must be provided to Multiquip Parts Sales that defines item numbers, quantities, and descriptions of the items to be returned.
  - a. The parts numbers and descriptions must match the current parts price list.
  - b. The list must be typed or computer generated.
  - c. The list must state the reason(s) for the return.
  - d. The list must reference the sales order(s) or invoice(s) under which the items were originally purchased.
  - e. The list must include the name and phone number of the person requesting the RMA.
3. A copy of the Return Material Authorization must accompany the return shipment.

4. Freight is at the sender's expense. All parts must be returned freight prepaid to Multiquip's designated receiving point.
5. Parts must be in new and resalable condition, in the original Multiquip package (if any), and with Multiquip part numbers clearly marked.
6. The following items are not returnable:
  - a. Obsolete parts. (If an item is listed in the parts price book as being replaced by another item, it is obsolete.)
  - b. Any parts with a limited shelf life (such as gaskets, seals, "O" rings, and other rubber parts) that were purchased more than six months prior to the return date.
  - c. Any line item with an extended dealer net price of less than \$5.00.
  - d. Special order items.
  - e. Electrical components.
  - f. Paint, chemicals, and lubricants.
  - g. Decals and paper products.
  - h. Items purchased in kits.
7. The sender will be notified of any material received that is not acceptable.
8. Such material will be held for 5 working days from notification, pending instructions. If a reply is not received within 5 days, the material will be returned to the sender at his expense.
9. Credit on returned parts will be issued at dealer net price at time of the original purchase, less a 15% restocking charge.
10. In cases where an item is accepted for which the original purchase document can not be determined, the price will be based on the list price that was effective twelve months prior to the RMA date.
11. Credit issued will be applied to future purchases only.

**PRICING AND REBATES**

Prices are subject to change without prior notice. Price changes are effective on a specific date and all orders received on or after that date will be billed at the revised price. Rebates for price declines and added charges for price increases will not be made for stock on hand at the time of any price change.

Multiquip reserves the right to quote and sell direct to Government agencies, and to Original Equipment Manufacturer accounts who use our products as integral parts of their own products.

**SPECIAL EXPEDITING SERVICE**

A \$20.00 to \$50.00 surcharge will be added to the invoice for special handling including bus shipments, insured parcel post or in cases where Multiquip must personally deliver the parts to the carrier.

**LIMITATIONS OF SELLER'S LIABILITY**

Multiquip shall not be liable here under for damages in excess of the purchase price of the item with respect to which damages are claimed, and in no event shall Multiquip be liable for loss of profit or good will or for any other special, consequential or incidental damages.

**LIMITATION OF WARRANTIES**

No warranties, express or implied, are made in connection with the sale of parts or trade accessories nor as to any engine not manufactured by Multiquip. Such warranties made in connection with the sale of new, complete units are made exclusively by a statement of warranty packaged with such units, and Multiquip neither assumes nor authorizes any person to assume for it any other obligation or liability whatever in connection with the sale of its products. A part from such written statement of warranty, there are no warranties, express, implied or statutory, which extend beyond the description of the products on the face hereof.



## **HERE'S HOW TO GET HELP**

*PLEASE HAVE THE MODEL AND SERIAL NUMBER  
ON-HAND WHEN CALLING*

### ***PARTS DEPARTMENT***

*800/427-1244 or 310/537-3700*

*FAX: 800/672-7877 or 310/637-3284*

### ***SERVICE DEPARTMENT***

*800/835-2551 or 310/537-3700*

*FAX: 310/638-8046*

### ***WARRANTY DEPARTMENT***

*800/835-2551 or 310/537-3700*

*FAX: 310/638-8046*

### ***MAIN***

*800/421-1244 or 310/537-3700*

*FAX: 310 - 537-3927*



**MULTIQUIP INC.**  
18910 WILMINGTON AVE.  
CARSON, CALIFORNIA 90746  
310-537-3700  
800-421-1244  
FAX: 310-537-3927  
E-mail: [mq@multiquip.com](mailto:mq@multiquip.com)

**PARTS DEPARTMENT:**  
800-427-1244  
FAX: 800-672-7877  
**SERVICE DEPARTMENT:**  
800-835-2551  
FAX: 310-638-8046  
[www.multiquip.com](http://www.multiquip.com)