

PARTS AND OPERATION MANUAL

MQ POWER MODEL DCA-180SSK GENERATOR (STANDARD)

© COPYRIGHT 2001, MULTIQIP INC.

PARTS LIST NO. C0874300704A
Revision #2 (05/09/01)



MULTIQIP INC.
18910 WILMINGTON AVE.
CARSON, CALIFORNIA 90746
310-537-3700
800-421-1244
FAX: 310-537-3927
E-mail: mq@multiquip.com • www.multiquip.com

PARTS DEPARTMENT:
800-427-1244
FAX: 800-672-7877

SERVICE DEPARTMENT:
800-835-2551
FAX: 310-638-8046



WARNING



CALIFORNIA — Proposition 65 Warning

Diesel engine exhaust and some of its constituents are known to the State of California to cause cancer, birth defects and other reproductive harm.

HERE'S HOW TO GET HELP

*PLEASE HAVE THE MODEL AND SERIAL NUMBER
ON-HAND WHEN CALLING*

PARTS DEPARTMENT

800/427-1244 or 310/537-3700

FAX: 800/672-7877 or 310/637-3284

SERVICE DEPARTMENT

800/835-2551 or 310/537-3700

FAX: 310/638-8046

WARRANTY DEPARTMENT

800/835-2551 or 310/537-3700

FAX: 310/638-8046

MAIN

800/421-1244 or 310/537-3700

FAX: 310 - 537-3927

TABLE OF CONTENTS

Here's How To Get Help	3	Generator Assembly	66-67
Table Of Contents	4	Control Panel Assembly	68-69
Parts Ordering Procedures	5	Control Box Assembly	70-71
Rules For Safe Operation	6-9	Engine Radiator Assembly	72-73
Towing	10	Engine Operating Panel Assembly	74-75
Trailer Safety Guidelines	11-17	Output Terminal Assembly	76-77
Trailer Wiring Diagram	18	Battery Assembly	78-79
Electrical Brake Troubleshooting	19	Muffler Assembly	80-81
Hydraulic Brake Troubleshooting	20	Enclosure Assembly	82-85
Operation And Safety Decals	21-24	Enclosure Lining Assembly	86-87
Specifications	25	Enclosure (Rubber Seals)	88-89
		Name Plate and Decals	90-93

MQ Power DCA-180SSK AC Generator

General Information	26-27
Major Components	28
Dimensions (Top, Side And Rear)	29
Control Panel	30-31
Engine Operating Panel	32-33
Output Terminal Panel Overview	34-39
Installation	40-41
Pre-Setup	42-45
Load Application	46
Generator Start-Up Procedure (Manual)	47-51
Generator Start-up Procedure (Auto)	52-53
Generator Shut-Down Procedure	54
Maintenance	55-57
Generator Wiring Diagram	58
Engine Wiring Diagram	59
Troubleshooting (Engine)	60-61
Troubleshooting (Engine/Generator)	62
Troubleshooting (MPEC)	63
Explanation Of Codes In Remarks Column	64
Suggested Spare Parts	65

Terms and Conditions Of Sale — Parts	94
--	----

NOTE

Specification and part number are subject to change without notice.

- Dealer account number
- Dealer name and address
- Shipping address (if different than billing address)
- Return fax number
- Applicable model number
- Quantity, part number and description of each part
- Specify preferred method of shipment:
 - UPS Ground
 - UPS Second Day or Third Day*
 - UPS Next Day*
 - Federal Express Priority One (please provide us with your Federal Express account number)*
 - Airborne Express*
 - Truck or parcel post

**Normally shipped the same day the order is received, if prior to 2PM west coast time.*

Earn Extra Discounts when you order by FAX!

All parts orders which include complete part numbers and are received by fax qualify for the following extra discounts:

<u>Number of line items ordered</u>	<u>Additional Discount</u>
1-9 items	3%
10+ items**	5%

Get special freight allowances when you order 10 or more line items via FAX! **

- UPS Ground Service at no charge for freight
- PS Third Day Service at one-half of actual freight cost

No other allowances on freight shipped by any other carrier.

**Common nuts, bolts and washers (all items under \$1.00 list price) do not count towards the 10+ line items.

DISCOUNTS ARE SUBJECT TO CHANGE

Fax order discount and UPS special programs revised June 1, 1995

**Extra Fax Discount
for Domestic USA
Dealers Only**

**Up to 5%
extra savings!**

**UPS
Special**
For faxed orders only

**Now! Direct TOLL-FREE access
to our Parts Department!**

Toll-free nationwide:

800-421-1244

Toll-free FAX:

800/6-PARTS-7 • 800-672-7877

RULES FOR SAFE OPERATION

CAUTION:



Failure to follow instructions in this manual may lead to serious injury or even death! This equipment is to be operated by trained and qualified personnel only! This equipment is for industrial use only.

The following safety guidelines should always be used when operating the DCA-180SSK portable generator:

GENERAL SAFETY

- **DO NOT** operate or service this equipment before reading this entire manual.



- This equipment should not be operated by persons under 18 years of age.

- **NEVER** operate this equipment without proper protective clothing, shatterproof glasses, steel-toed boots and other protective devices required by the job.



- **NEVER** operate this equipment when not feeling well due to fatigue, illness or taking medicine.



- **NEVER** operate this equipment under the influence of drugs or alcohol.



- **NEVER** use accessories or attachments, which are not recommended by MQ Power for this equipment. Damage to the equipment and/or injury to user may result.

- Manufacturer does not assume responsibility for any accident due to equipment modifications.

- Whenever necessary, replace nameplate, operation and safety decals when they become difficult read.

- Always check the machine for loosened threads or bolts before starting.

- **NEVER** touch the hot exhaust manifold, muffler or cylinder. Allow these parts to cool before servicing engine or generator.



- **High Temperatures** – Allow the engine to cool before adding fuel or performing service and maintenance functions. Contact with *hot* components can cause serious burns.

- The engine of this generator requires an adequate free flow of cooling air. **NEVER** operate the generator in any enclosed or narrow area where free flow of the air is restricted. If the air flow is restricted it will cause serious damage to the generator or engine and may cause injury to people. The generator engine gives off **DEADLY** carbon monoxide gas.

CAUTION:



- Always refuel in a well-ventilated area, away from sparks and open flames.



- Always use extreme caution when working with **flammable** liquids. When refueling, **stop the engine** and allow it to cool. **DO NOT** smoke around or near the machine. Fire or explosion could result from fuel vapors, or if fuel is spilled on a hot engine.

- **NEVER** operate the generator in an explosive atmosphere or near combustible materials. An explosion or fire could result causing severe *bodily harm or even death*.

- Topping-off to filler port is dangerous, as it tends to spill fuel.

RULES FOR SAFE OPERATION

CAUTION:

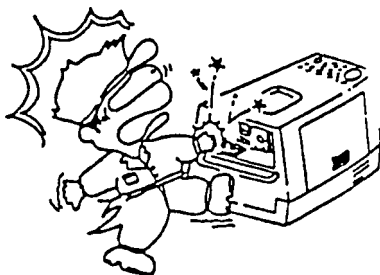

- **NEVER** touch output terminals during operation. This is extremely dangerous. Always stop the machine when contact with the output terminals.

CAUTION:

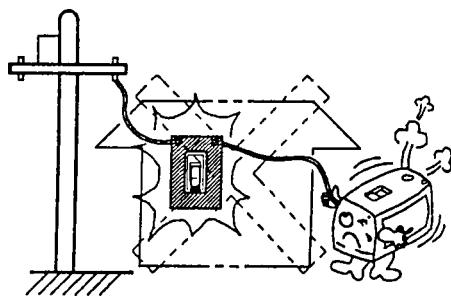

- **Backfeed to a utility system can cause electrocution and/or property damage. Do not connect to any building's electrical system except through an approved device or after building main switch is opened.**

CAUTION:



Never use damaged or worn cables when connecting power tools or equipment to the generator. Make sure power connecting cables are securely connected to the generator's output terminals, insufficient tightening of the terminal connections may cause damage to the generator and electrical shock.

CAUTION:



- **DO NOT** touch or open any of the below mentioned components while the generator is running. Always allow sufficient time for the engine and generator to cool before performing maintenance.

Radiator

1. **Radiator Cap** - Removing the radiator cap while the engine is hot will result in high pressurized, boiling water to gush out of the radiator, causing severe scalding to any persons in the general area of the generator.
2. **Coolant Drain Plug** - Removing the coolant drain plug while the engine is hot will result in hot coolant to gush out of the coolant drain plug, therefore causing severe scalding to any persons in the general area of the generator.
3. **Engine Oil Drain Plug** - Removing the engine oil drain plug while the engine is hot will result in hot oil to gush out of the oil drain plug, therefore causing severe scalding to any persons in the general area of the generator.

Battery

CAUTION:



Never over fill the battery with water above the upper limit.

The battery contains acids that can cause injury to the eyes and skin. To avoid eye irritation, always wear safety glasses. Use well insulated gloves when picking up the battery. Use the following guidelines when handling the battery:

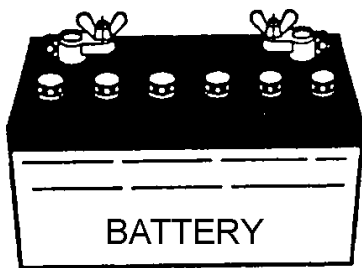

1. **DO NOT** drop the battery. There is the possibility of risk that the battery may explode.
 2. **DO NOT** expose the battery to open flames, sparks, cigarettes etc. The battery contains combustible gases and liquids. If these gases and liquids come in contact with a flame or spark, an explosion could occur.
 3. Always keep the battery charged. If the battery is not charged a buildup of combustible gas will occur.
 4. Always keep battery charging and booster cables in good working condition. Repair or replace all worn cables.
 5. Always recharge the battery in an open air environment, to avoid risk of a dangerous concentration of combustible gases.
 6. In case the battery liquid (dilute sulfuric acid) comes in contact with **clothing or skin**, rinse skin or clothing immediately with plenty of water.
 7. In case the battery liquid (dilute sulfuric acid) comes in contact with your **eyes**, rinse eyes immediately with plenty of water, then contact the nearest doctor or hospital, and seek medical attention.
- **NEVER** Run engine without air filter. Severe engine damage may occur.
 - Always service air cleaner frequently to prevent carburetor malfunction.
 - Always disconnect the battery before performing service on the generator.
 - Always be sure the operator is familiar with proper safety precautions and operations techniques before using generator.
 - Always store equipment properly when not in use. Equipment should be stored in a clean, dry location out of the reach of children.
 - **DO NOT** leave the generator running in the manual mode unattended.
 - **DO NOT** allow unauthorized people to operate this equipment.
 - Always read, understand, and follow procedures in Operator's Manual before attempting to operate equipment.
 - Refer to the ***Komatsu Engine Owner's Manual*** for engine technical questions or information.

Loading and Unloading (Crane)

- Before lifting, make sure the generator's lifting hook is secure and that there is no apparent damage to the generator itself (loose screws, nuts and bolts). If any part is loose or damaged, please take corrective action before lifting.
- Always drain fuel prior to lifting.
- Always make sure crane or lifting device has been properly secured to the hook of guard frame on generator.
- **NEVER** lift the machine while the engine is running.
- Use adequate lifting cable (wire or rope) of sufficient strength.
- When lifting the generator, always use the balanced center-point suspension hook and lift straight upwards.
- **NEVER** allow any person or animal to stand underneath the machine while lifting.
- When loading the generator on a truck, be sure to use the front and back frame bars as a means to secure the generator during transport.

Transporting

- Always shutdown engine before transporting.
- Tighten fuel tank cap securely.
- Drain fuel when transporting generator over long distances or bad roads.
- Always tie-down the generator during transportation by securing the generator.
- If generator is mounted on a trailer, make sure trailer complies with all local and state safety transportation laws. See page 10 for basic towing procedures.

Emergencies

- Always know the location of the nearest **fire extinguisher** and **first aid kit**. Know the location of the nearest telephone. Also know the phone numbers of the nearest **ambulance**, **doctor** and **fire department**.

Maintenance Safety

- **NEVER** lubricate components or attempt service on a running machine.
- Always allow the machine a proper amount of time to cool before servicing.
- Keep the machinery in proper running condition.
- Fix damage to the machine immediately and always replace broken parts.
- Dispose of hazardous waste properly. Examples of potentially hazardous waste are used motor oil, coolant, fuel, and fuel filters.
- **DO NOT** use plastic containers to dispose of hazardous waste.
- **DO NOT** pour waste, oil, coolant or fuel directly onto the ground, down a drain or into any water source

Towing Safety Precautions

CAUTION:



Check with your county or state safety towing regulations department before towing your generator.

To reduce the possibility of an accident while transporting the generator on public roads, always make sure the trailer (Figure 1) that supports the generator and the towing vehicle are in good operating condition and both units are mechanically sound.

The following list of suggestions should be used when towing your generator:

- Make sure the hitch and coupling of the towing vehicle are rated equal to, or greater than the trailer "gross vehicle weight rating" (GVWR).
- **ALWAYS** inspect the hitch and coupling for wear. **NEVER** tow a trailer with defective hitches, couplings, chains etc.
- Check the tire air pressure on both towing vehicle and trailer. Also check the tire tread wear on both vehicles.
- **ALWAYS** make sure the trailer is equipped with a "Safety Chain".

- **ALWAYS** attach trailer's safety chain to bumper of towing vehicle.
- **ALWAYS** make sure the vehicle and trailer directional, backup, brake, and trailer lights are connected and working properly.
- Remember the maximum speed unless otherwise posted for highway towing is **45 MPH**. Recommended off-road towing is not to exceed **10 MPH** or less depending on type of terrain.
- Place *chocked blocks* underneath wheel to prevent **rolling**, while parked.
- Place *support blocks* underneath the trailer's bumper to prevent **tipping**, while parked.
- Use the trailer's hand winch to adjust the height of the trailer, then insert locking pin to lock wheel stand in place, while parked.
- Avoid sudden stops and starts. This can cause skidding, or jackknifing. Smooth, gradual starts and stops will improve gas mileage.
- Avoid sharp turns to prevent rolling.
- Remove wheel stand when transporting.
- **DO NOT** transport generator with fuel in tank.

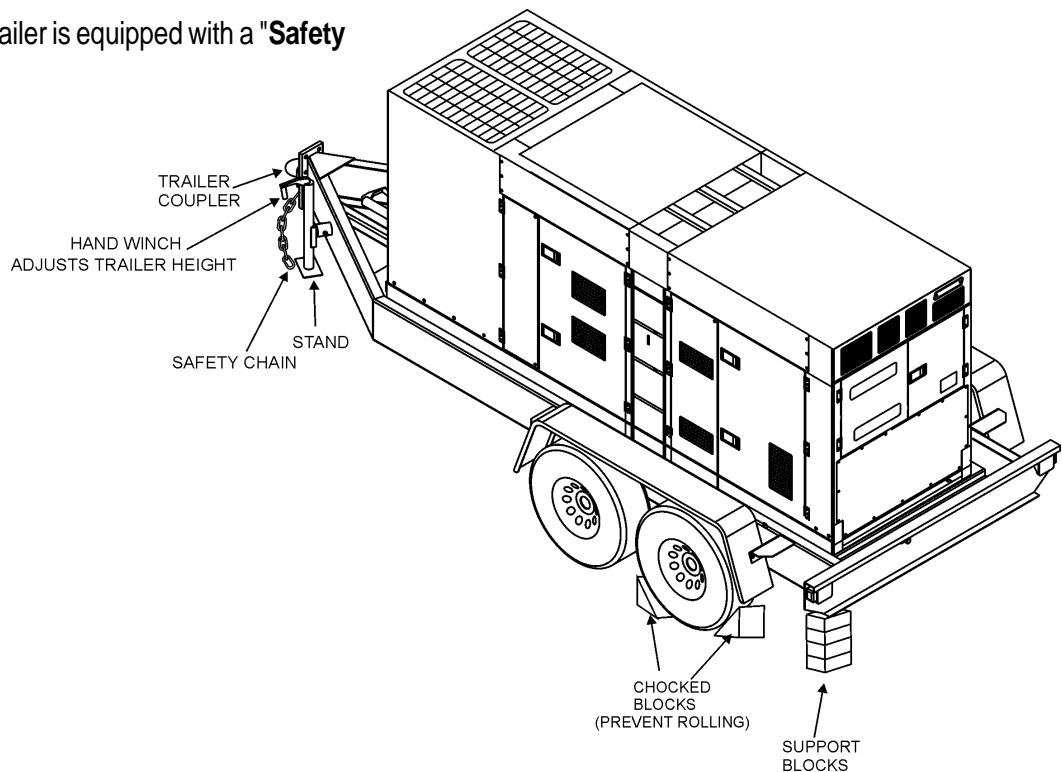

Figure 1. Generator with Trailer

CAUTION:



ALWAYS make sure the trailer is in good operating condition. Check the tires for proper inflation and wear. Also check the wheel lug nuts for proper tightness.

Explanation of Chart:

This section is intended to provide the user with trailer service and maintenance information. The service and maintenance guidelines referenced in this section apply a wide range of trailers. Remember periodic inspection of the trailer will ensure safe towing of the equipment and will prevent damage to the equipment and personal injury.

It is the purpose of this section to cover the major maintenance components of the trailer. The following trailer components will be discussed in this section:

- Brakes
- Tires
- Lug Nut Torquing
- Suspension
- Electrical
- Brake Troubleshooting Tables

Use the following definitions while reading Table 1.

1. **Fuel Cell** - Provides an adequate amount of fuel for the equipment in use. Fuel cells must be empty when transporting equipment.
2. **Braking System** - System employed in stopping the trailer. Typical braking systems are electric, surge, hydraulic, hydraulic-surge and air.
3. **GVWR**- Gross Vehicle Weight Rating (GVWR), is the maximum number of pounds the trailer can carry, including the fuel cell (empty).
4. **Frame Length** - This measurement is from the ball hitch to the rear bumper (reflector).
5. **Frame Width** - This measurement is from fender to fender.
6. **Jack Stand** - Trailer support device with maximum pound requirement from the tongue of the trailer.
7. **Coupler** - Type of hitch used on the trailer for towing.
8. **Tire Size** - Indicates the diameter of the tire in inches (10,12,14, etc.), and the width in millimeters (175,185,205, etc.). The tire diameter must match the diameter of the tire rim.
9. **Tire Ply** - The tire ply (layers) number is rated in letters; 2-ply,4-ply,6-ply, etc.
10. **Wheel Hub** - The wheel hub is connected to the trailer's axle.
11. **Tire Rim** - Tires are mounted on a tire rim. The tire rim must match the size of the tire.
12. **Lug Nuts** - Used to secure the wheel to the wheel hub. Always use a torque wrench to tighten down the lug nuts. See Table 4 and Figure 5 for lug nut tightening and sequence.
13. **Axle** - Indicates the maximum weight the axle can support in pounds, and the diameter of the axle expressed in inches (see Table 3 on page 17). Please note that some trailers have a double axle. This will be shown as 2-6000 lbs., meaning two axles with a total weight capacity of 6000 pounds.
14. **Suspension** - Protects the trailer chassis from shock transmitted through the wheels. Types of suspension used are leaf, Q-flex, and air ride.
15. **Electrical** - Electrical connectors (looms) are provided with the trailer so the brake lights and turn signals can be connected to the towing vehicle. See page 16 for proper wiring connections.
16. **Application** - Indicates which units can be employed on a particular trailer.

DCA-180SSK — TRAILER-SPECIFICATIONS

Table 1. Specifications

MODEL	APPLICATION	FUEL CELL	BRAKE SYSTEM	GVWR	FRAME LENGTH	FRAME WIDTH	JACK STAND
TRLR-10-15	TLG-12, DCA15, TLW-300	NO	NO	1900LBS	96"	50"	800LB. FULL TILT WHEEL
TRLR-10X	TLG-12, DCA15, TLW-300	NO	NO	1900LBS	96"	50"	800LB. FULL TILT WHEEL
TRLR-10XF	TLG-12, DCA15, TLW-300	51 GAL	NO	1900LBS	96"	50"	800LB. FULL TILT WHEEL
TRLR-225W	DCA-10	NO	NO	2200LBS	85"	42"	800LB. FULL TILT WHEEL
BLW-400	BLW-400	NO	ELECTRIC	2700LBS	W/MAST 154" W/O 124"	55" (78" TALL)	800LB. FULL TILT WHEEL
TRLR-15XF	DCA-15	41 GAL	NO	2700LBS	124"	55"	800LB. FULL TILT WHEEL
TRLR-50X	DCA-25	NO	NO	2700LBS	124"	55"	800LB. FULL TILT WHEEL
TRLR-50XF	DCA-25	41 GAL	NO	2700LBS	124"	55"	800LB. FULL TILT WHEEL
TRLR-25SBT	DCA-25	NO	NO	2990LBS	120"	66"	800LB. FULL TILT WHEEL
TRLR-70W	DCA-45, -60, 70	NO	SURGE	7000LBS	186"	77"	2000LB. FLAT PAD
TRLR-70X	DCA-45, -60, 70	OPT	SURGE	7000LBS	138"	66"	2000LB. FLAT PAD
TRLR-70XF	DCA-45, -60, 70	53 GAL	SURGE	7000LBS	138"	66"	2000LB. FLAT PAD
TRLR-100XF	DCA-100, 125	150 GAL	HYDRAULIC SURGE	7000LBS	190"	76"	2000LB. FLAT PAD
TRLR-85/125	DCA-85, 100, 125	145 GAL	HYDRAULIC	10000LBS	186"	77"	2000LB. FLAT PAD
TRLR-150XF	DCA-150, 180	200 GAL	HYDRAULIC SURGE	11160LBS	204"	84"	5000 LB. FLAT PAD
TRLR-220XF	DCA-220	250 GAL	HYDRAULIC SURGE	14000LBS	222"	83"	5000 LB. FLAT PAD
TRLR-300XF	DCA-300	250 GAL	HYDRAULIC SURGE	18000LBS	238"	83"	5000 LB. FLAT PAD
TRLR-400XF	DCA-400	350 GAL	ELECTRIC	18000LBS	238"	83"	5000 LB. FLAT PAD
TRLR-600XF	DCA-600, 800	550 GAL	AIR	30000LBS	384"	96"	5000 LB. FLAT PAD
TRLR-800SX	DCA-600, 800	550 GAL	AIR	30000LBS	384"	96"	5000 LB. FLAT PAD

DCA-180SSK — TRAILER-SPECIFICATIONS

Table 1. Specifications (Con't)

MODEL	COUPLER	TIRES	WHEELS	AXLE	HUBS	SUSPENSION	ELECTRICAL
TRLR-10-15W	2" BALL CLASS 2 ADJUSTABLE	175-13C	13"X4.50"	2200# 2X2	5 LUG	3 LEAF	4 WIRE LOOM W/ 4 POLE FLAT
TRLR-10X	2" BALL CLASS 2 ADJUSTABLE	175-13C	13"X4.5"	2200#2X2	5 LUG	3 LEAF	4 POLE FLAT
TRLR-10XF	2" BALL CLASS 2 ADJUSTABLE	175-13C	13"X4.5"	2200#2X2	5 LUG	3 LEAF	4 POLE FLAT
TRLR-225W	2" BALL CLASS 2 ADJUSTABLE	175-13B	13X4.5"	2200#2X2	5 LUG	Q FLEX	4 POLE FLAT
BLW 400	2" BALL CLASS 2 ADJUSTABLE	175-13C	13 X 4.5"	2200#2X2	5 LUG	3 LEAF	4 POLE FLAT
TRLR-15XF	2" BALL CLASS	B78-13LRC	13"X4.50"	3500# 2-1/2"	5 LUG	4 LEAF	4 POLE RUBBER FLAT
TRLR-50X	2" BALL CLASS	B78-13LRC	13"X4.50"	3500lbs. 2-3/8"	5 LUG	4 LEAF	4 POLE RUBBER FLAT
TRLR-50XF	2" BALL CLASS	B78-13LRC	13"X4.50"	3500lbs. 2-3/8"	5 LUG	4 LEAF	4 POLE RUBBER FLAT
TRLR-70W	2" BALL CLASS 3" ADJUSTABLE	205-14C BIAS (4)	14"X5"	3500lbs. 3"	5 LUG	5 LEAF	4 POLE RUBBER FLAT
TRLR-70X	2" BALL CLASS 3" ADJUSTABLE	205-14C BIAS (4)	14"X5"	3500lbs 3"	5 LUG	5 LEAF	4 POLE RUBBER FLAT
TRLR-70XF	2" BALL CLASS 3" ADJUSTABLE	205-14C BIAS (4)	14"X5"	3500lbs. 3"	5 LUG	5 LEAF	4 POLE RUBBER FLAT
TRLR-100XF	ADJUSTABLE 2-5/6 OPT 3" EYE	205-15C BIAS (4)	14"X5.5"	3500lbs 3"	5 LUG	5 LEAF	4 WIRE LOOM
TRLR-85/125	ADJUSTABLE 2-5/6 OPT 3" EYE	ST225/75R15D RADIAL (4)	14"x6"	(2)-6000lbs	6 LUG	7 LEAF	4 WIRE LOOM
TRLR-150XF	3" BALL EYE	750-16 E BIAS (4)	16"X7"	(2)-6000lbs	8 LUG	7 LEAF	4 WIRE LOOM
TRLR-220XF	3" EYE ADJUSTABLE	ST235/85R16E RADIAL(4)	16"X7"	(2)-7000lbs	8 LUG	Q FLEX	4 WIRE LOOM
TRLR-300XF	3" EYE ADJUSTABLE	ST235/85R16E RADIAL(6)	16"X7"	(2)-6000lbs	8 LUG	Q FLEX	4 WIRE LOOM
TRLR-400XF	3" EYE ADJUSTABLE	ST235/85R16E RADIAL(6)	16"X7"	(3)-7000lbs.	8 LUG	Q FLEX	4 WIRE LOOM
TRLR-600XF	5TH WHEEL	ST215/75R17.5H RADIAL (8)	16"X7"	(3)-10000lbs	8 LUG	7 LEAF	6 WIRE LOOM
TRLR-800AR	5TH WHEEL	ST215/75R17.5H RADIAL (8)	16"X7"	(3)-10000lbs	8 LUG	AIR-RIDE	6 WIRE LOOM

Brakes

If your trailer has a braking system, the brakes should be inspected the first 200 miles of operation. This will allow the brake shoes and drums to seat properly. After the first 200 mile interval, inspect the brakes every 3,000 miles. If driving over rough terrain, inspect the brakes more frequently.

Electric Brakes

Electrically actuated brakes (Figure 2) are similar to hydraulic brakes. The basic difference is that hydraulic brakes are actuated by an electromagnet.

Listed below are some of the advantages that electric brakes have over hydraulic brakes:

- Brake system can be manually adjusted to provide the corrected braking capability for varying road and load conditions
- Brake system can be modulated to provide more or less braking force, thus easing the brake load on the towing vehicle
- Brake system has very little lag time between the time the vehicle's brakes are actuated and the trailer's brakes are actuated
- Brake system can provide an independent emergency brake system

Remember in order to properly synchronize the tow vehicle's braking to the trailer's braking, can only be accomplished by road testing. Brake lockup, grabbiness or harshness is due to lack of synchronization between the tow vehicle and the trailer being towed or under-adjusted brakes.

Before any brake synchronizations adjustments can be made, the trailer brakes should be burnished-in by applying the brakes 20-30 times with approximately a 20 m.p.h. decrease in speed, e.g. 40 m.p.h. to 20 m.p.h. Allow ample time for brakes to cool between application. This allows the brake shoes to slightly be seated into the brake drum surface.

Figure 2 displays the major electric brake components that will require inspection and maintenance. Please inspect these components as required.

Electric Brake Adjustment

1. Place the trailer on jack stands. Make sure the jack stands are placed on secure level ground.
2. Check the wheel and drum for free rotation.
3. Remove the adjusting hole cover from the adjusting slot at the bottom brake backing plate.
4. With a screwdriver or standard adjusting tool, rotate the star wheel of the adjuster assembly to expand the brake shoes.
5. Adjust the brake shoes outward until the pressure of the lining against the wheel drum makes the wheel difficult to turn.
6. Rotate the star wheel in the opposite direction until the wheel rotates freely with slight lining drag.
7. Replace the adjusting hole cover and lower the trailer to the ground.
8. Repeat steps 1 through 6 on the remaining brakes.

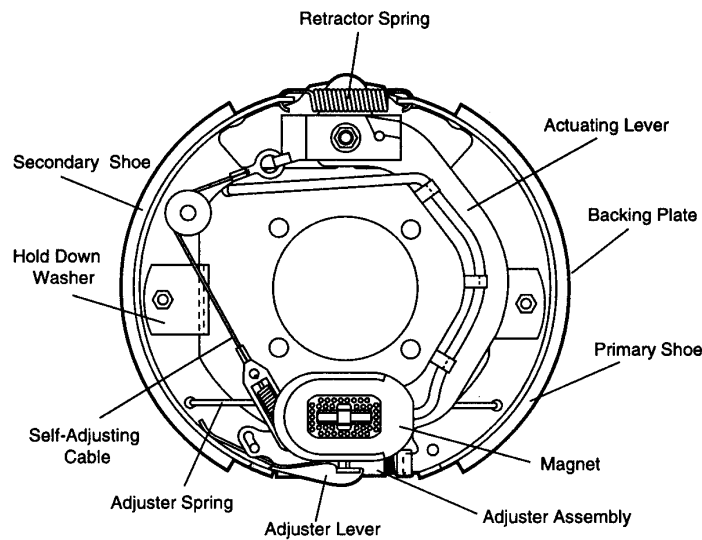

Figure 2. Electrical Brake Components

Hydraulic/Air/Surge Brakes

Hydraulic brakes (Figure 3) should not require any special attention with the exception of routine maintenance such as shoe and lining replacement. These brakes can be adjusted in the same manner as electric brakes. Brake lines should be periodically checked for cracks, kinks, or blockage. Figure 3 below displays the major hydraulic/air/surge brake

components that will require inspection and maintenance. Please inspect these components as required using steps 1 through 6 as referenced in the electric brake adjustments section.

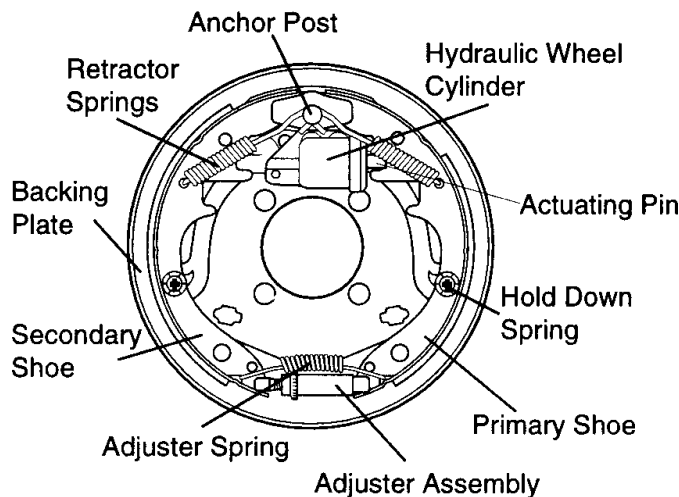

Figure 3. Hydraulic Brake Components

Tires/Wheels/Lug Nuts

Tires and wheels are a very important and critical components of the trailer. When specifying or replacing the trailer wheels it is important the wheels, tires, and axle are properly matched.

CAUTION:



DO NOT attempt to repair or modify a wheel. DO NOT install in inner tube to correct a leak through the rim. If the rim is cracked, the air pressure in the inner tube may cause pieces of the rim to explode (break off) with great force and cause serious eye or bodily injury.

cause serious eye or bodily injury.

Tire Wear/Inflation

Tire inflation pressure is the most important factor in tire life. Pressure should be checked cold before operation DO NOT bleed air from tires when they are hot. Check inflation pressure weekly during use to insure the maximum tire life and tread wear.

Table 2 (Tire Wear Troubleshooting) will help pinpoint the causes and solutions of tire wear problems.

WEAR PATTERN		CAUSE	SOLUTION
	Center Wear	Over Inflation.	Adjust pressure to particular load per tire manufacturer.
	Edge Wear	Under Inflation.	Adjust pressure to particular load per tire manufacturer.
	Side Wear	Loss of chamber or overloading.	Make sure load does not exceed axle rating. Align wheels.
	Toe Wear	Incorrect toe-in.	Align wheels.
	Cupping	Out-of-balance.	Check bearing adjustment and balance tires.
	Flat Spots	Wheel lockup & tire skidding.	Avoid sudden stops when possible and adjust brakes.

Suspension

The leaf suspension springs and associated components (Figure 4) should be visually inspected every 6,000 miles for signs of excessive wear, elongation of bolt holes, and loosening of fasteners. Replace all damaged parts (suspension) immediately. Torqued suspension components as detailed in Table 3.

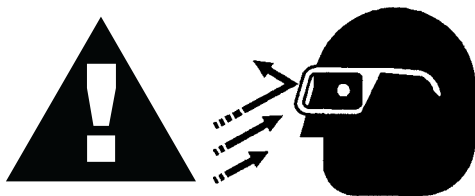

NOTE

ALWAYS wear safety glasses when removing or installing force fitted parts. Failure to comply may result in serious injury.

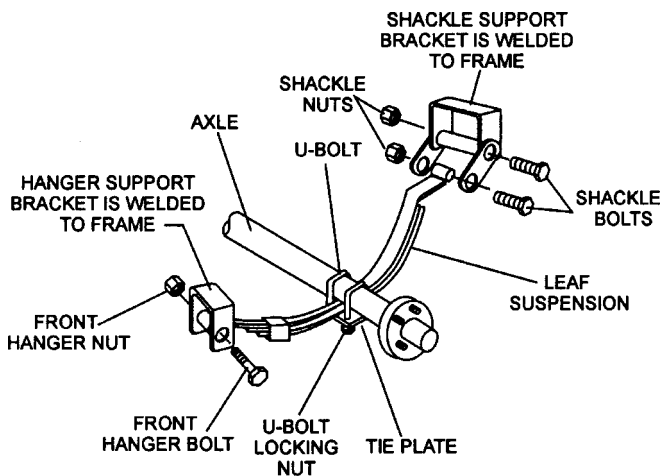

Figure 4. Major Suspension Components

Table 3. Suspension Torque Requirements

Item	Torque (Ft.-Lbs.)
3/8" U-BOLT	MIN-30 MAX-35
7/16" U-BOLT	MIN-45 MAX-60
1/2" U-BOLT	MIN-45 MAX-60
SHACKLE BOLT SPRING EYE BOLT	SNUG FIT ONLY. PARTS MUST ROTATE FREELY. LOCKING NUTS OR COTTER PINS ARE PROVIDED TO RETAIN NUT-BOLT ASSEMBLY.
SHOULDER TYPE SHACKLE BOLT	MIN-30 MAX-50

Lug Nut Torque Requirements

It is extremely important to apply and maintain proper wheel mounting torque on the trailer. Be sure to use only the fasteners matched to the cone angle of the wheel. Proper procedure for attachment of the wheels is as follows:

1. Start all wheel lug nuts by hand.
2. Torque all lug nuts in sequence. See Figure 5. DO NOT torque the wheel lug nuts all the way down. Tighten each lug nut in 3 separate passes as defined by Table 4.
3. After first road use, retorque all lug nuts in sequence. Check all wheel lug nuts periodically.

Table 4. Tire Torque Requirements

Wheel Size	First Pass FT-LBS	Second Pass FT-LBS	Third Pass FT-LBS
12"	20-25	35-40	50-65
13"	20-25	35-40	50-65
14"	20-25	50-60	90-120
15"	20-25	50-60	90-120
16"	20-25	50-60	90-120

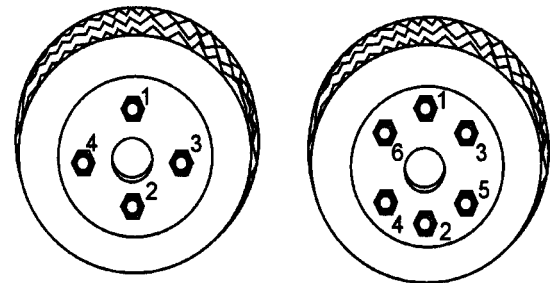

4-LUG NUTS

6-LUG NUTS

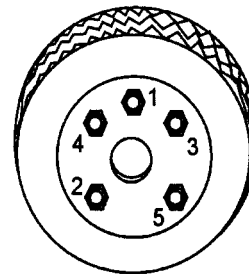

5-LUG NUTS

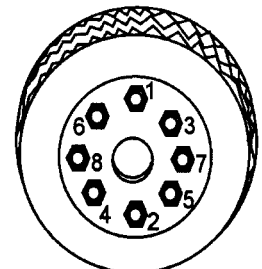

8-LUG NUTS

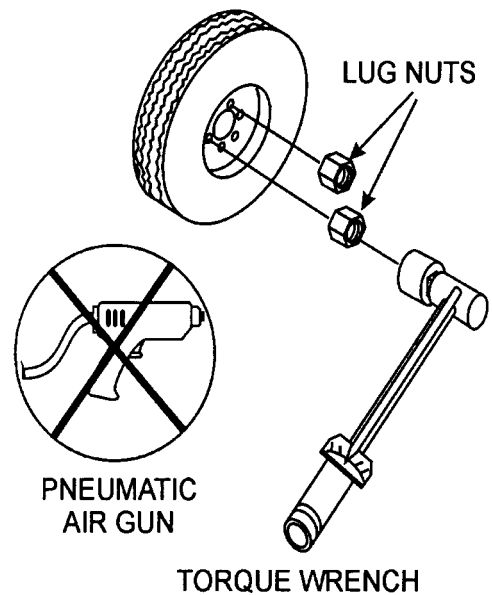

Figure 5. Wheel Lug Nuts Tightening Sequence

NOTE

NEVER use an pneumatic air gun to tighten wheel lug nuts.

DCA-180SSK —TRAILER-WIRING DIAGRAM

TRAILER SIDE

TOWING VEHICLE SIDE

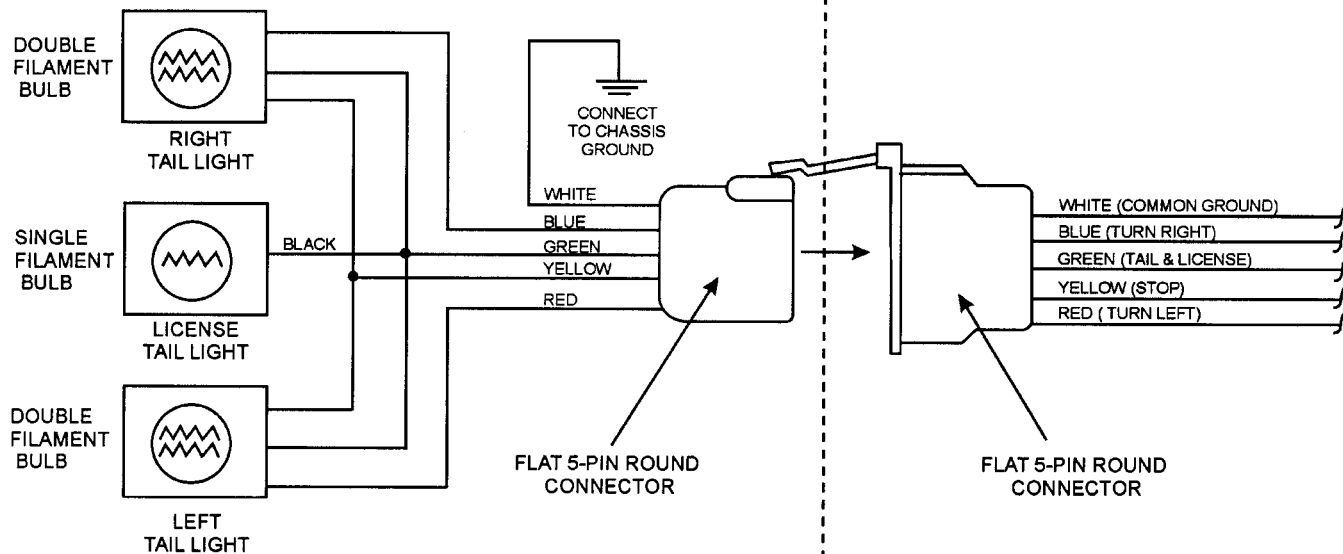
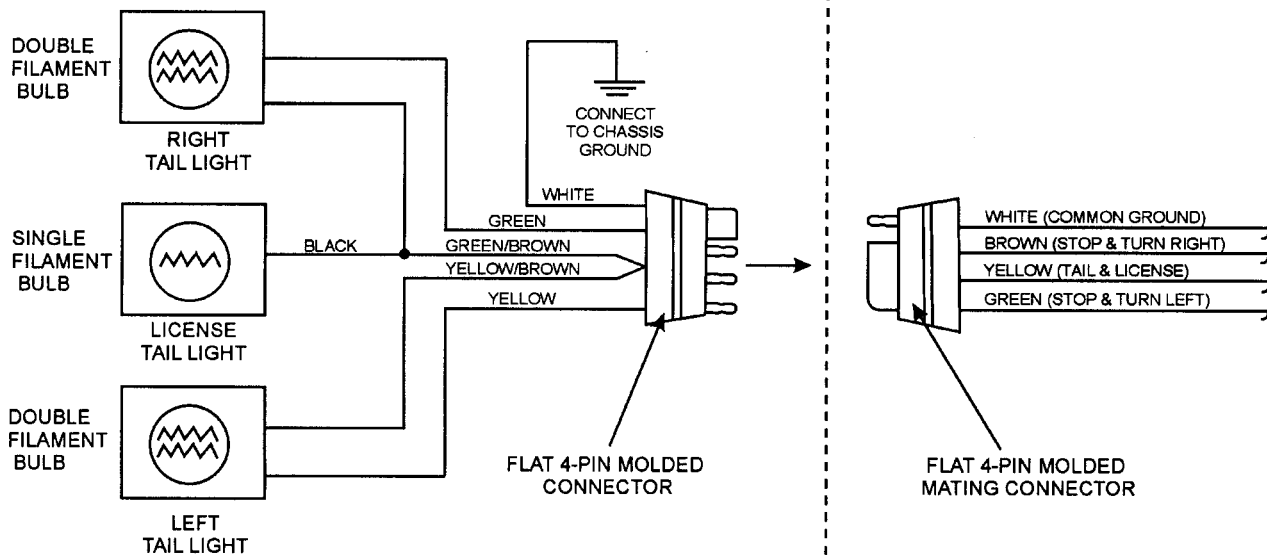

NOTE:
LIGHTS ARE ORIENTED FROM THE DRIVER'S SEAT

Table 5. Electric Brake Troubleshooting

Symptom	Possible Cause	Solution
No Brakes or Intermittent Brakes	Any open circuits or broken wires?	Find and correct.
	Any short circuits?	Find and correct.
	Faulty controller?	Test and correct.
	Any loose connections?	Find and repair.
	Ground wire secure?	Find and secure.
Weak Brakes or Brakes Pull to One Side	Grease or oil on magnets or linings?	Clean or replace.
	Connections corroded?	Clean and correct cause of corrosion.
	Brake drums scored or grooved?	Machine or replace.
	Brakes synchronized?	Correct.
Locking Brakes	Brake components loose, bent or broken?	Replace components.
	Brake drums out-of-round?	Replace.
Noisy Brakes	System lubricated?	Lubricate.
	Brake components correct?	Replace and correct.
Dragging Brakes	Bearings of the wheel adjusted?	Adjust.

Table 6. Hydraulic Brake Troubleshooting

Symptom	Possible Cause	Solution
No Brakes	Brake line broken or kinked?	Repair or replace.
Weak Brakes or Brakes Pull to One Side	Brake lining glazed?	Reburnish or replace.
	Trailer overloaded?	Correct weight.
	Brake drums scored or grooved?	Machine or replace.
	Tire pressure correct?	Inflate all tires equally.
	Tires unmatched on the same axle?	Match tires.
Locking Brakes	Brake components loose, bent or broken?	Replace components.
	Brake drums out-of-round?	Replace.
Noisy Brakes	System lubricated?	Lubricate.
	Brake components correct?	Replace and correct.
Dragging Brakes	Brake lining thickness correct or in right wrong position?	Install new shoes and linings.
	Enough brake fluid or correct fluid?	Replace rubber parts fill with dot4 fluid.

DCA-180SSK — OPERATION AND SAFETY DECALS

Machine Safety Decals

The DCA-180SSK generator is equipped with a number of safety decals. These decals are provided for operator safety and maintenance information. The illustration below and on the preceding pages shows the decals as they appear on the machine. Should any of these decals become unreadable, replacements can be obtained from your dealer.

GENERAL

HANDLING PROCEDURES

1. CHECK TO OPERATING
Prior to operating the engine, be sure to check the following items to prevent trouble and accidents:

- (1) Check lubricating oil, cooling water and diesel fuel.
- (2) Check the tension of the fan-belt and charging generator driving belt.
- (3) Check the CIRCUIT BREAKER is turned "OFF".
- (4) Set the voltage change-over board to the rated voltage (only Dual voltage type).

2. STARTING AND OPERATING

- (1) Turn the battery switch to "ON" position.
- (2) Turn the STARTER SWITCH to "PREHEAT" position for 10 ~ 30 seconds.
Press the STARTER SWITCH to "START" POSITION to start the engine.
When the engine starts, release the STARTER SWITCH.
- (3) Warm-up the engine for about 5 minutes.
- (4) Rotate the THROTTLE HANDLE to "HIGH SPEED" and adjust the engine speed according to the following table.

No-load operating speed	
50 Hz operation	Approx. 52.5 Hz (1575 rpm)
60 Hz operation	Approx. 62.5 Hz (1875 rpm)

- (5) Adjust the VOLTAGE REGULATOR to the rated voltage.
- (6) Turn on the CIRCUIT BREAKER to supply electric power to the load.

3. OPERATING PRECAUTIONS

- (1) While operating do not turn the BATTERY SWITCH "OFF" to protect the charging generator and engine circuit against damage.
- (2) When the CIRCUIT BREAKER is tripped "OFF" for over current or short-circuit, check the trouble cause and repair defective parts.
The CIRCUIT-BREAKER cannot be reset unless it is once turned "OFF" and next turned "ON".

4. STOPPING THE ENGINE

- (1) Turn the Circuit Breaker to "OFF".
Rotate the THROTTLE HANDLE TO THE "Low Speed" side.
Cool-down the engine for about 5 minutes.
- (2) Depress the STOP BUTTON.
After the engine stops completely, turn "OFF" STARTER SWITCH and BATTERY SWITCH.

S-2763

P/N 0800655603

CONTROL BOX GROUP

SAFETY INSTRUCTIONS

Improper operation of this machine can cause severe injury or death.

- Read the instruction manual carefully before operating or servicing.

This machine should only be operated by a person with sufficient knowledge and skill to ensure safe operation.

High voltage circuits are located inside the output terminal cover and control panel.

- Close the cover and control panel before operating.

Moving parts and hot surfaces are contained within the enclosure.

- Close all doors and lock them before operating.

C2510000

P/N C255100004

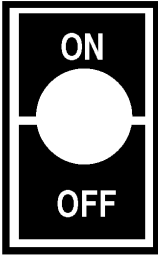

P/N 0800520100

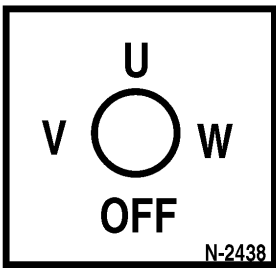

N-2438
P/N 0800520904

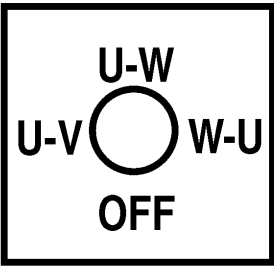

P/N 0800520814

SETTING FOR OUTPUT VOLTAGE (240V)

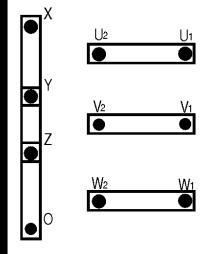

(480V)

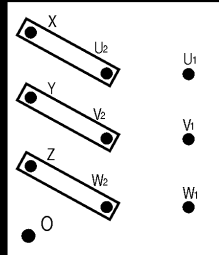

Tighten hexagon head bolts securely.

C0510090

P/N C0551000903

WHISPERWATT 180



MQ POWER CORP.
WHISPERWATT 180
180 KVA AC GENERATOR
MODEL DCA-180SSK

C06110340

P/N C0561103403

CIRCUIT BREAKER

S-3031

P/N 08406 24504

PILOT LAMP

S-3033

P/N 0840624704

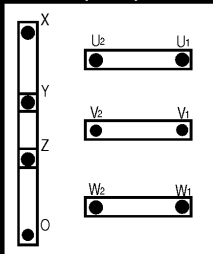

P/N B9531100604

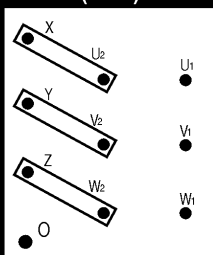

P/N 0840624804

ENGINE & RADIATOR GROUP

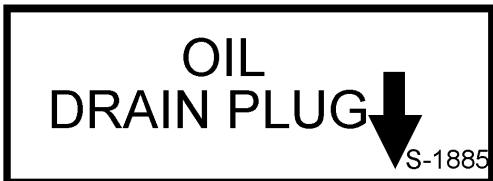

P/N 63606 20204



P/N 63606 10304



P/N B9511100404

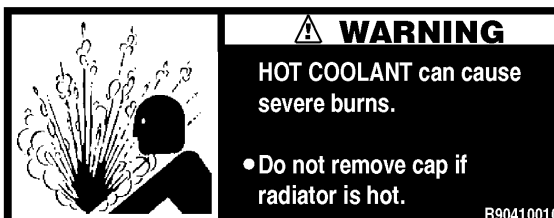

P/N B9504100104

ENGINE OPERATING PANEL GROUP



P/N 0840625004



P/N C0551000704



P/N C0551000704



P/N C0551000804

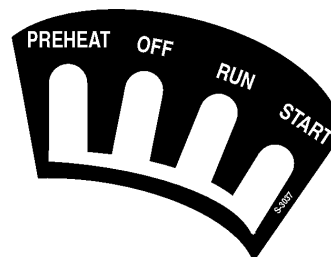

P/N 0840625104

DCA-180SSK — OPERATION AND SAFETY DECALS

ENGINE & RADIATOR GROUP

OUTPUT TERMINAL GROUP

GROUND
S-2635

P/N 0840614104

DANGER
HIGH VOLTAGE
S-2731

P/N 08040619904

240/139 VOLT
C15100040

P/N C1551000404



WARNING
ELECTRIC SHOCK HAZARD

- Do not touch output terminals while this machine is operating.
- Turn power off before servicing.

B93110050

P/N B9531100504



WARNING
ELECTRIC SHOCK HAZARD

- Always complete the grounding path from the ground terminal on this genset to an external grounding source. See instruction manual for details.

B91110040

P/N B9511100404

WARNING

- Before connecting this generator to any building's electrical system, a licensed electrician must install an isolation (transfer) switch.
- Serious injury or death may result without this transfer switch.

B91110030

P/N B9511100304

3-Phase output terminal
Keep the loads balancing when using plural single loads.

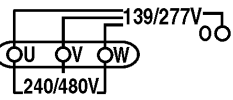

C05100040

P/N C0551000404

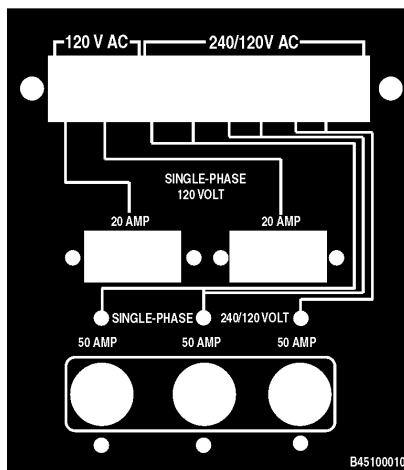

P/N B4551000103

BATTERY GROUP

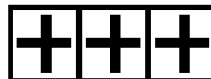

P/N 08006 89404

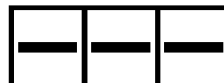

P/N 08006 89504

MUFFLER GROUP



WARNING

- Only operate machine in well ventilated areas.
- Do not inhale exhaust gases.

DANGEROUS GAS Only qualified personnel should install, use, or service this equipment.

P/N B950420004

FUEL TANK GROUP



P/N 6360620004



P/N B9504500004



P/N 1320620904

ENCLOSURE GROUP



P/N 0840625902



P/N C0551000404

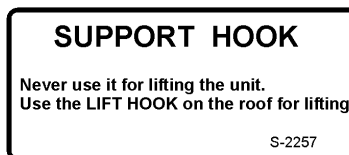

P/N 13206 21504

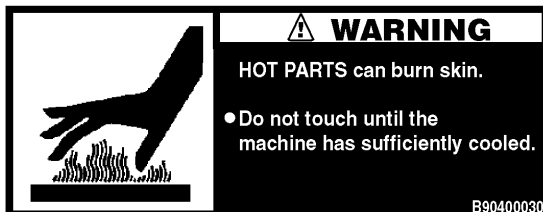

P/N B9504000304

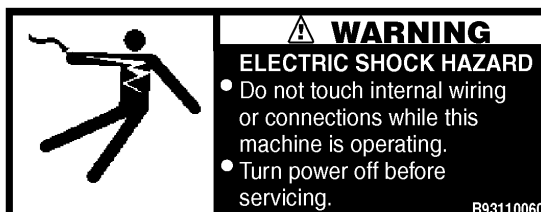

P/N B9531100604

Table 7. Specifications	
Generator Specifications	
Model	DCA-180SSK
Type	Revolving field, self ventilated, open protected type synchronous generator
Armature Connection	Star with Neutral
Phase	3
Standby Output	198 KVA (158.4 KW)
Prime Output	180 KVA (144 KW)
Voltage	240V or 480V
Frequency	60 Hz
Speed	1800 rpm
Power Factor	0.8
Aux. AC Power	Single Phase, 60 Hz
Voltage	120 V
Output	4.8 KW (2.4 KW x 2)
Engine Specifications	
Model	KOMATSU SA6D108E-2
Type	4 Cycle, water-cooled, direct injection, turbo-charged with after-cooler
No. of Cylinders	6 cylinders
Bore x Stroke	4.2 in. x 5.1 in. (108 mm x 130 mm)
Rated Output	217 HP/1800 rpm
Displacement	436 cu. in. (7150 cc)
Starting	Electric
Coolant Capacity	6.1 gal. (23 liters)
Lube Oil Capacity	6.6 gal. (25 liters)
Fuel Consumption	9.6 gal. (36.4 liters)/hr (at full load)
Battery	12V- 120 AH x 2
Fuel	#2 Diesel Fuel

DCA-180SSK FAMILIARIZATION

Generator

The MQ Power Model DCA-180SSK is a 144 kW *generator* that has been designed as a high quality portable (requires a trailer for transport) power source for telecom sites, lighting facilities, power tools, submersible pumps and other industrial and construction machinery.

Engine Control Panel

The "Engine Control Panel" is provided with the following:

- Tachometer
- Water Temperature Gauge
- Oil Pressure Gauge
- Charging Ammeter Gauge
- Engine Speed Switch
- Pre-Heat Button
- Pre-Heat Lamp
- Emergency Stop Button
- Battery Switch
- Ignition Key Switch
- MPEC Module (on some models)

Generator Control Panel

The "Generator Control Panel" is provided with the following:

- Output Voltage Adjustment Knob
- Frequency Meter (Hz)
- AC Ammeter (Amps)
- AC Voltmeter (Volts)
- Ammeter Change-Over Switch
- Voltmeter Change-Over Switch
- Panel Light
- Panel Light Switch
- Pilot Lamp

Output Terminal Panel

The "Output Terminal Panel" is provided with the following:

- Two 120V GFCI receptacles, 20 amp
- Three 240/139V output receptacles, 50 amp
- Two 120V input receptacles, 20 amp
- 3 Load Circuit Breakers 265V @65 amps
- 2 Load GFCI Circuit Breakers 265V@ 20amps

Control Box

The "Control Box" is provided with the following:

- Main Circuit Breaker 500 amps
- Over-Current Relay
- High Idle Adjust Trimmer

Microprocessor Controlled Alarm System

The DCA-180SSK generator is equipped with various alarms and LED status indicators. These alarms and status indicators are provided to add safety to the generator when operating under normal conditions. The DCA-180SSK generator is designed to shutdown in the event of low oil, high coolant temperature, low battery and other operation conditions that may cause severe damage to the generator.

Open Delta Excitation System

The DCA-180SSK generator is equipped with the state of the art "*Open-Delta*" excitation system. The open delta system consist of an electrically independent winding wound among stationary windings of the AC output section.

There are four connections: A, B, C and D. During steady loads, the power to the *Automatic Voltage Regulator* (AVR) is supplied from the parallel connections of A to B, A to D, and C to D. These three phases are rectified and are used as the current for the exciter section.

During a heavy load, such as motor starting, the AVR switches the configuration of the Open-Delta to the series connection B to C. This has the effect of adding the voltages of each phase to provide better voltage response during heavy loads.

The connections of the AVR to the AC output windings are for the sole purpose of sensing. No power is required from these windings.

The open-delta design provides virtually unlimited excitation current due to its independent power supply offering maximum motor starting capabilities. The excitation does not have a "*fixed ceiling*" and responds according the demands of the required load.

Engine

The **DCA-180SSK** is powered by a 4 cycle, water cooled, turbocharged KOMATSU Model SA6D108E-2 *diesel* gasoline engine. This engine is designed to meet every performance requirement for the generator. Reference Table 7, page 25 for engine specifications.

In keeping with MQ Power's policy of constantly improving its products, the specifications quoted herein are subject to change without prior notice.

The basic controls and indicators for the DCA-180SSK generator are addressed on the following pages.

Mechanical Governor System

The mechanical governor system control the RPM of the engine. When the engine demands increase or decrease, the mechanical governor system regulates the frequency variation to $\pm 1.0\%$. The electronic governor option increases frequency variation to $\pm 0.25\%$.

Electronic Governor System

The electronic governor system is made up of two parts, an electronic controller that monitors frequency variation as the load increases and decreases and an electronic actuator that controls the engine throttle. The frequency is regulated at ± 0.25 to help protect sensitive equipment.

Jacket Water Heater (OPTIONAL)

The jacket water heater is a 1500-watt heater designed to keep the coolant from freezing in the engine block. The heater is thermostatically controlled and once an acceptable engine temperature is achieved it will cycle on and off, operating only about 1/3 of the time. This becomes a very energy efficient option compared to a direct immersion block heater. It is designed to keep the engine between 100 and 120 degrees Fahrenheit. This is not a throwaway heater. It is completely serviceable.

In normal conditions, 20 to 15 minutes is all that is required to raise the engine temperature of a cold engine to 100 degrees Fahrenheit.

CAUTION :

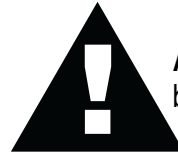

ALWAYS unplug the jacket water heater before servicing.

There is a bleed screw on the valve on the engine block. After service of either the heater or the cooling system, it is possible to create an air bubble in this area. The air bubble would prevent hot water created by the jacket water heater from circulating, if the air bubble were not allowed to escape. This bleed screw allows for the bleeding process to be accomplished.

Battery Charger (OPTIONAL)

The battery charger will operate in a 'BOOST' mode until the battery's current acceptance falls to 70% of the charger's rating. The charger will then go into a 'FLOAT' mode, where it discharges a lower voltage until an AC failure, or the battery is discharged.

Fuel Water Separator

The fuel water separator separates water mixed in the fuel. It has an indicator to let the operator know to drain the water. See maintenance section for instructions how to drain water from separator.

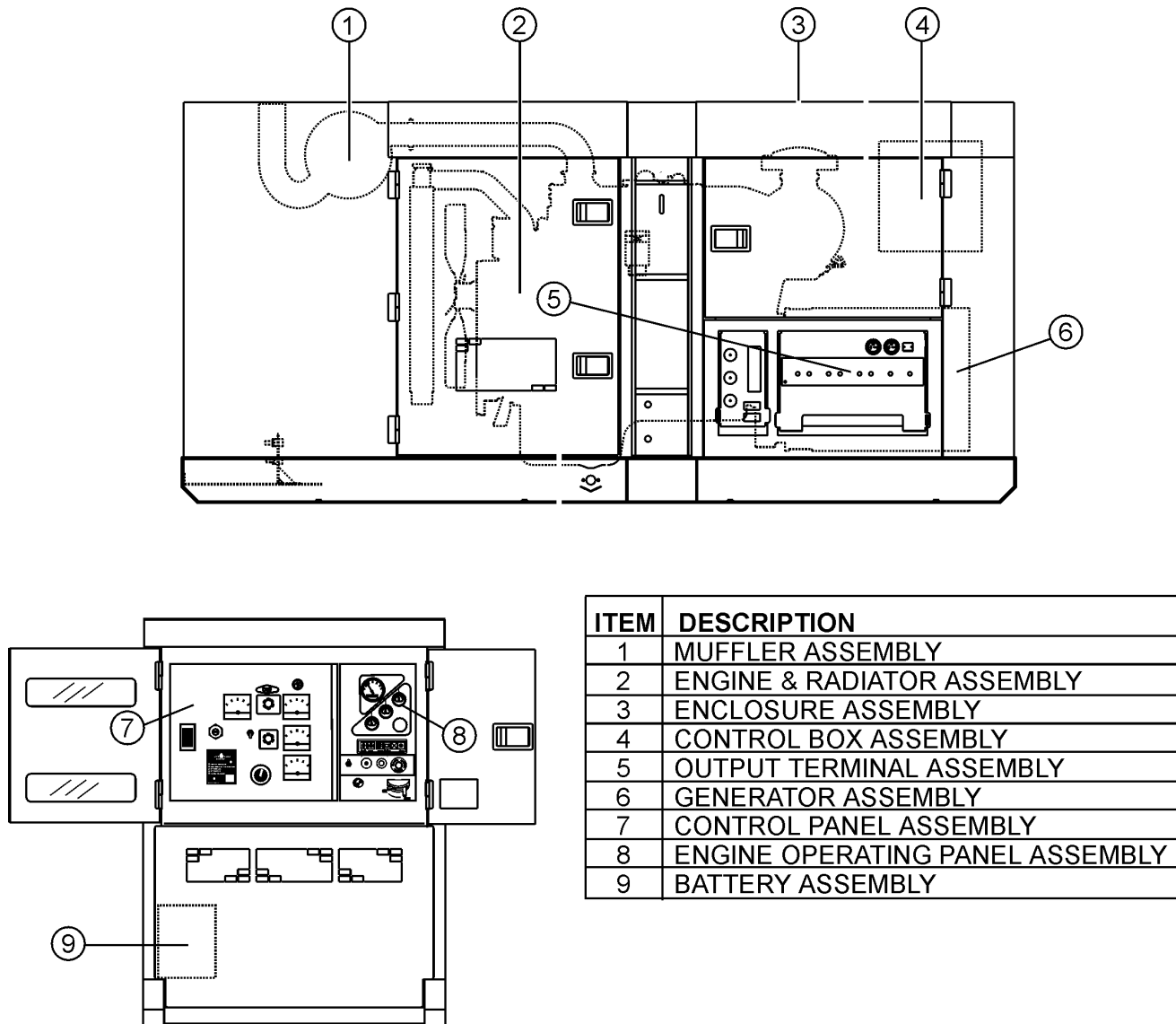

ITEM	DESCRIPTION
1	MUFFLER ASSEMBLY
2	ENGINE & RADIATOR ASSEMBLY
3	ENCLOSURE ASSEMBLY
4	CONTROL BOX ASSEMBLY
5	OUTPUT TERMINAL ASSEMBLY
6	GENERATOR ASSEMBLY
7	CONTROL PANEL ASSEMBLY
8	ENGINE OPERATING PANEL ASSEMBLY
9	BATTERY ASSEMBLY

Figure 6. Major Components

DCA-180SSK — DIMENSIONS (TOP, SIDE, AND REAR)

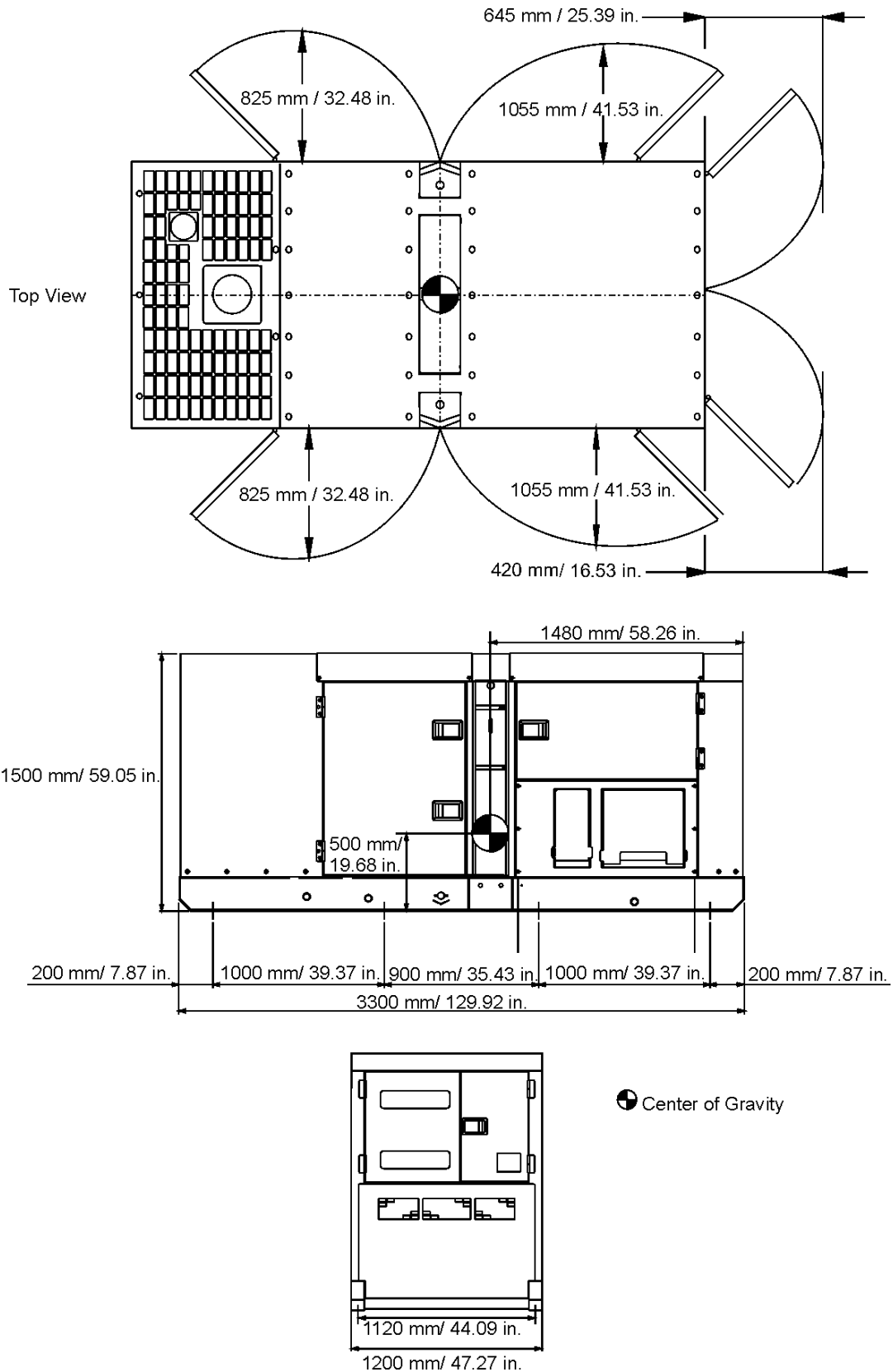
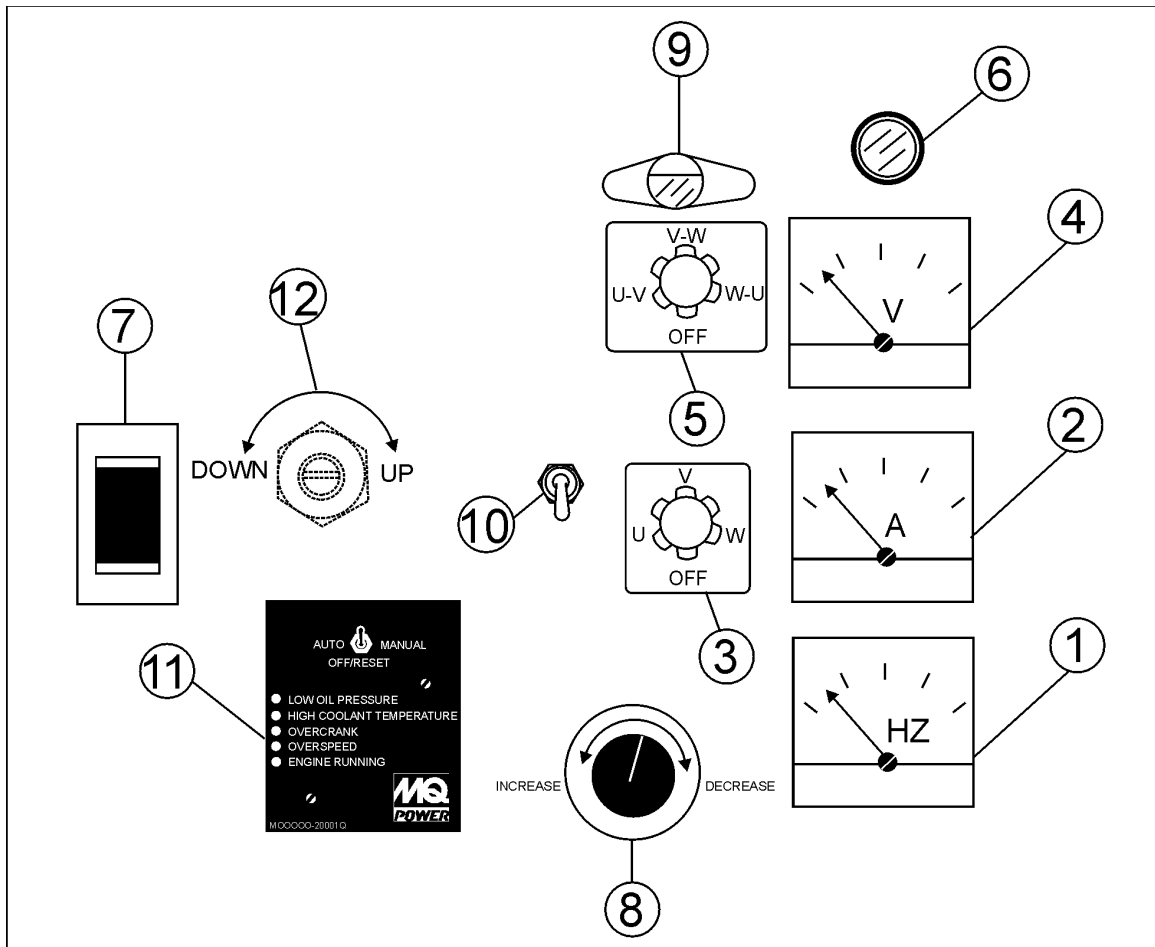

Figure 7. Dimensions



NO	DESCRIPTION
1	FREQUENCY METER
2	AC AMMETER
3	AMMETER CHANGE-OVER SWITCH
4	AC VOLTMETER
5	VOLTMETER CHANGE-OVER SWITCH
6	PILOT LAMP
7	CIRCUIT BREAKER
8	VOLTAGE REGULATOR
9	PANEL LIGHT
10	PANEL LIGHT SWITCH
11	MPEC
12	HIGH IDLE ADJUST TRIMMER

Figure 8. Control Panel

The definitions below describe the controls and functions of the DCA-180SSK " **Control Panel**" (Figure 8).

1. **Frequency Meter** – Indicates the output frequency in hertz (Hz). Normally 60 Hz \pm 1 Hz .
2. **AC Ammeter** – Indicates the amount of current the load is drawing from the generator.
3. **Ammeter Change-Over Switch** – This switch allows the AC ammeter to indicate the current flowing to the load connected to any phase of the output terminals, or to be switched off.
4. **AC Voltmeter** – Indicates the single phase output voltage present at the UVW terminals.
5. **Voltmeter Change-Over Switch** – This switch allows the AC voltmeter to indicate phase to phase voltage between any two phases of the output terminals or to be switched off.
6. **Pilot Lamp** – Indicates that the generator is working properly.
7. **Main Circuit Breaker** – This three-pole, 500 amp main breaker is provided to protect the UVW voltage output terminals from overload.
8. **Voltage Regulator Control** – Allows manual adjustment of the generator's output voltage.
9. **Panel Light** – Normally used in dark areas or at night time. When activated, panel lights will illuminate. When the generator is not in use be sure to turn the panel light switch to the OFF position.
10. **Panel Light Switch** – When activated will turn on control panel light.
11. **MPEC – Microprocessor Engine Control Module** – (MPEC) has a vertical row of status LED's (Figure 9), that when lit, indicate that an engine malfunction (fault), has been detected. When a fault has been detected the MPEC will evaluate the fault and if the fault is major will shutdown the generator.



Figure 9. MPEC Module

During **cranking cycle** , The MPEC will attempt to crank the engine for 10 seconds before disengaging.

If the engine does not engage (start) by the third attempt, the engine will be shutdown by the MPEC's " Over Crank Protection" mode. If the engine engages at a speed (RPM's) that is not safe, the MPEC will shutdown the engine by initializing the "Over Speed Protection" mode.

Also the MPEC will shutdown the generator in the event of low oil pressure, high coolant temperature, low coolant level, and loss of magnetic pickup. These conditions can be observed by monitoring the LED status indicators on the front of the MPEC module.

- A. **Off/Manual/Auto Switch** – This switch controls the running of the generator. If this switch is left in the "OFF" position, the generator will not run. When this switch is set to the **manual** position, the generator will start immediately.

If the generator is to be connected to a building's AC power source via a transfer switch (isolation), place the switch in the **auto** position. In this position the generator will monitor the AC line output from the building's power source.

- B. **Low Oil Pressure** – Indicates the engine pressure has fallen below 15 psi. The oil pressure is detected using variable resistive values from the oil pressure sending unit. This is considered a **major** fault.
- C. **High Coolant Temperature** – Indicates the engine temperature has exceeded 215°F. The engine temperature is detected using variable resistive values from the temperature sending unit. This is considered a **major** fault.
- D. **Overcrank Shutdown** – Indicates the unit has attempted to start a pre- programmed number of times, and has failed to start. The number of cycles and duration are programmable. Typical programmable start settings is 3 cycles with a 10 second duration .This is considered a **major** fault.
- E. **Overspeed Shutdown** – Indicates the engine is running at an unsafe speed. This is considered a **major** fault.
- F. **Engine Running** – Indicates that engine is running at a safe operating speed.

12. **High Idle Adjust Trimmer** – Use this trimmer to adjust the engine speed.

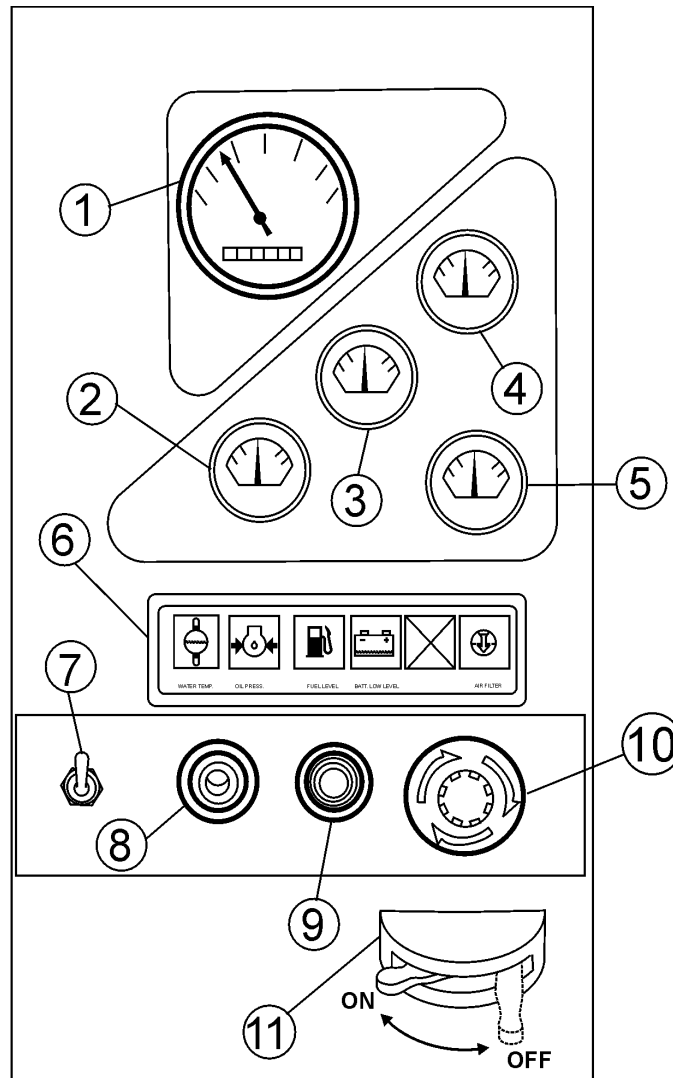

NO	DESCRIPTION
1	TACHOMETER
2	CHARGING AMMETER GAUGE
3	OIL PRESSURE GAUGE
4	WATER TEMPERATURE GAUGE
5	FUEL LEVEL GAUGE
6	WARNING LAMP MONITOR
7	IDLE CONTROL SWITCH
8	PRE-HEAT LAMP
9	PRE-HEAT BUTTON
10	EMERGENCY STOP BUTTON
11	BATTERY SWITCH

Figure 10. Engine Operating Panel

DCA-180SSK — ENGINE OPERATING PANEL

The definitions below describe the controls and functions of the DCA-180SSK " **Engine Operating Panel** " (Figure 10).

1. **Tachometer** – Indicates engine speed in RPM's for 60 Hz operation. This meter should indicate 1800 RPM's when the rated load is applied. In addition a built in hour meter will record the number of operational hours that the generator has been in use.
2. **Charging Ammeter Gauge** – Indicates the current being supplied by the engine's alternator which provides current for generator's control circuits and battery charging system.
3. **Oil Pressure Gauge** – During normal operation this gauge be should read in the "GREEN" zone. When starting the generator the oil pressure mar read a little bit higher, but after the engine warms up the oil pressure should return to the green zone.
4. **Water Temperature Gauge** – During normal operation this gauge be should read in the "GREEN" zone.
5. **Fuel Gauge** - Detects the amount of fuel available for operation.
6. **Engine Warning Display Module** – This module display's the following engine failures:

A. **Overheat Lamp** – This lamp goes ON when the cooling water temperature rises abnormally. If the lamp goes ON during normal operation of the generator, the emergency shutdown device will stop the engine automatically.

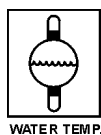

B. **Low Oil Pressure Lamp** – During normal operation of the generator this lamp should remain OFF. When the Auto-OFF/Reset-Manual switch is set to the "Manual" position to start the engine, the lamp will be lit. After the oil pressure rises after start-up the lamp will go OFF. If this lamp is ever lit (ON) during normal operation of the generator, the emergency shutdown device will stop the engine automatically.



C. **Low Fuel Level Lamp** – When this lamp is ON, it is time to stop the engine and add fuel. Remember to let the engine cool before adding fuel.



D. **Low Battery Fluid Lamp** – This lamp goes ON when the battery fluid is low. If this lamp goes ON during normal operation of the generator, stop the engine and fill the battery with distilled water to the specified level.



E. **Clogged Air Filter Lamp** – This lamp goes ON when the air filter is clogged. If this lamp goes ON during normal operation of the generator, stop the engine and replace the air filter.



7. **Speed Switch**- Adjusts the speed of the engine from high to low.

8. **Pre-Heat Lamp** – Indicates that the glow plugs of the diesel engine are hot and the engine is ready to be started.



9. **Pre-Heat Button** – Press hold this button until the preheat lamp is lit (ON).



10. **Emergency Stop Switch** – Push this button inward to stop the engine in the event of an emergency. **DO NOT** use this button as a means of stopping the engine. Turn the button clockwise to disengage the stop function.



11. **Battery Switch** – This switch should be set to the ON position during normal operation. When the engine has been stop, place this switch in the OFF position. **DO NOT** turn this switch during normal operation, it could cause damage to the electrical equipment.

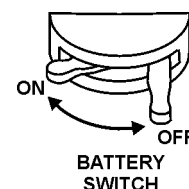

DCA-180SSK — OUTPUT TERMINAL PANEL OVERVIEW

OUTPUT TERMINAL FAMILIARIZATION

The "Output Terminal Panel" is provided with the following:

- Two 120V GFCI receptacles, 20 amp
- Three 240/139V output receptacles, 50 amp
- Two 120V input receptacles, 20 amp (optional)
- 3 Load Circuit Breakers 265V @65 amps
- 2 Load GFCI Circuit Breakers 265V@ 20amps

Control Box

The "Control Box" is provided with the following:

- Main Circuit Breaker 500 amps
- Over-Current Relay

Output Terminal Panel

The Output Control Panel (See Figure 4) is located on the right hand side (left from control panel) of the generator. The UVW lugs are protected by a face plate cover that can be secured in the close position by a pad lock. (See Figure 11).

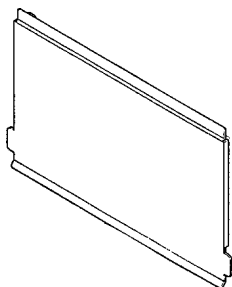

FIGURE 12. Output Terminal Cover

120 Volt Receptacle

Two GFCI Duplex Nema 5-20R (120V, 20 Amp) receptacle is provided on the output terminal. This receptacle can be used anytime the generator is in operation. The receptacle is controlled by the circuit breaker located on the control panel.

Pressing the reset button resets the receptacle after being tripped. Pressing the "Test Button" (See Figure 12) in the center of this receptacle will check the GFCI function. The receptacle should be tested at least once a month.

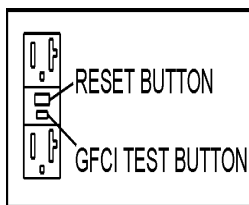

FIGURE 12. GFCI Test Button

Connecting Load

Loads can be connected to the generator by the UVW Lugs or the convenience receptacles. (See figure 13). Make sure to read the operation manual before attempting to connect a load to the generator.

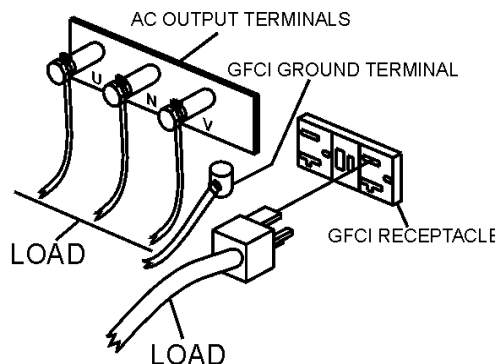

FIGURE 13. Connecting Load

Circuit Breakers

To protect the generator from an overload, a 3-pole, 500 amp, **main** circuit breaker is provided to protect the UVW output terminals from overload. In addition two single-pole, 20 amp **GFCI** circuit breakers are provided to protect the GFCI receptacles from overload. Three 50 amp **load** circuit breakers have also been provided to protect the load side of the generator from overload. Make sure to switch **ALL** circuit breakers to the "OFF" position prior to starting the engine.

Maximum Output

The entire load connected to the UVW Lugs, all four slots in the duplex receptacles, and the must not exceed 158 kW in standby or 144 kW in prime output.

Twist Lock Dual Voltage Receptacles

Three CS-6369 auxiliary power receptacles have been provided to supply 208/120V. The voltage regulator knob on the control panel may need to be used to adjust the voltage to 208 or 416V.

Input Receptacles

Two 120 volt, 20 amp input receptacles are provided to supply power to accessories, such as the battery charger (optional) or jacket water heater (optional).

DCA-180SSK — OUTPUT TERMINAL PANEL OVERVIEW

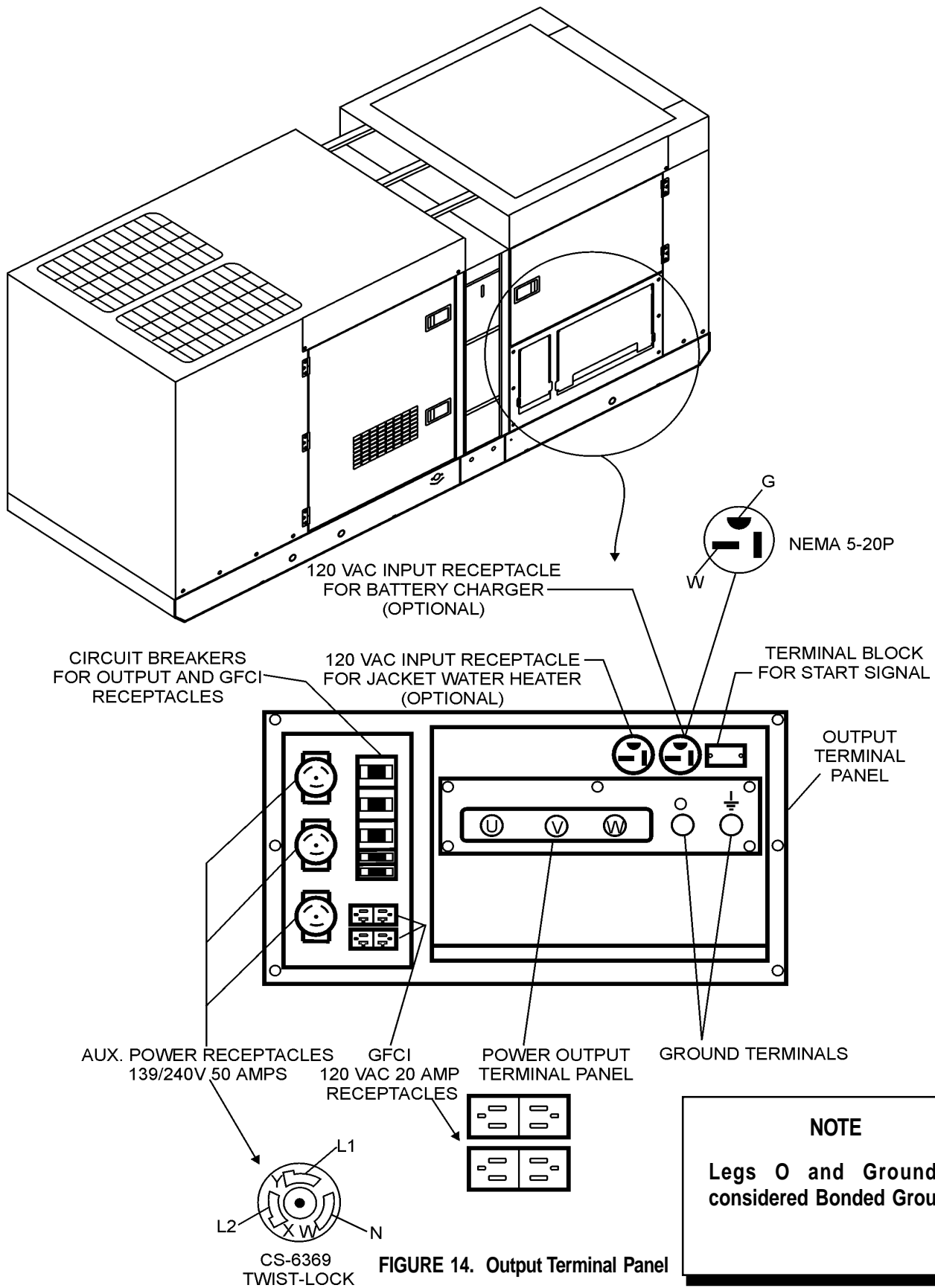

FIGURE 14. Output Terminal Panel

DCA-180SSK — OUTPUT TERMINAL PANEL OVERVIEW

Output Terminal Panel Available Voltages

A wide range of voltages are available to supply load to many different applications. Voltages may be selected by using the voltage change-over board and how you hookup your hard wire connection to the generator. To obtain some of the voltages listed, fine adjustment with the Voltage Regulator on the control panel is necessary. See the table below (Table 8) for a list of available voltages the generator is able to supply.

TABLE 8. VOLTAGES AVAILABLE						
MODEL	DCA180SSK					
3 PHASE VOLTAGE (RECONNECTABLE)	208 VOLT	220 VOLT	240 VOLT	416 VOLT	440 VOLT	480 VOLT
SINGLE PHASE (ADJUSTABLE)	120 VOLT	127 VOLT	139 VOLT	240 VOLT	254 VOLT	277 VOLT

CAUTION :



NEVER attempt to change the Voltage Change-over board while the engine is engaged.

Over Current Relay

An over current relay is connected to the circuit breaker. In an over current situation, both the circuit breaker and the over current relay may trip. If the circuit breaker can not be reset, the reset button on the over current relay must be pressed. The over current relay is located in the control box.

Maximum Amps

The following table show the maximum amps the entire generator can provide. Do not exceed the maximum amps listed. (See Table 9)

Table 9. Maximum Amps

Model:	DCA180SSK
Rated Voltage	Maximum Amps
Single Phase 120 Volt	400.0 amps (4 wire)
Single Phase 240 Volt	200.0 amps (4 wire)
Three Phase 240 Volt	433.0 amps
Three Phase 480 Volt	216.5 amps

How to read the output terminal gauges.

The gauges and knobs on the control panel **DO NOT** effect the generator output in any fashion. They are there to simply help the operator observe how much power is being produced at the UVWO legs.

To read the output of the W-U legs, for example, place the AC Voltmeter Change-over switch to the W-U position and the AC ammeter Change-over Switch to the U or W position to read the output on the selected leg.

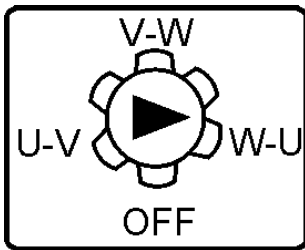

FIGURE 15. AC Voltmeter Change-over switch (Reading the W-U leg on the output terminal panel)

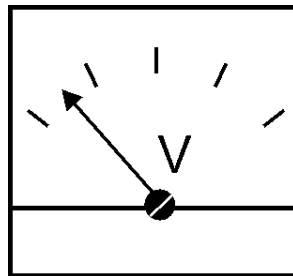

FIGURE 16. AC Voltmeter Gauge (Volt reading on W-U Lug)

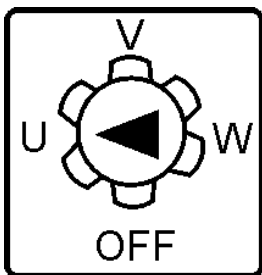

FIGURE 17. AC Ammeter Change-over Switch (Reading the U leg on the output terminal panel)

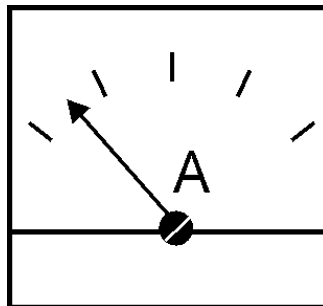

FIGURE 18. AC Ammeter (Amp reading on U lug)

DCA-180SSK — OUTPUT TERMINAL PANEL OVERVIEW

Voltage Change-over Board

The voltage change-over board changes the available voltages of the output terminal panel UVWO lugs. The voltage change-over board is located on the control box behind the control panel. There are six (6) plates that can be set into two set positions to get six different voltages. Unless specified differently, the generator comes from the factory in the 240V position.

240 Volt Set position

The voltage change-over board 240V set position uses all 6 plates in 6 different connection places. See figure 19 below.

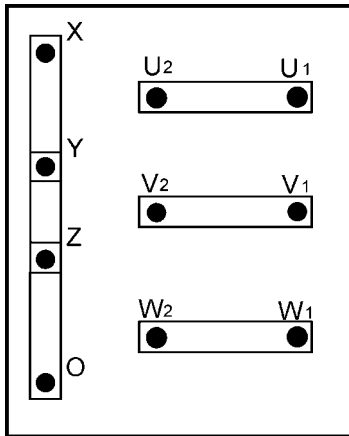

FIGURE 19. Voltage Change-over Board 240V set position.

3 Phase, 240 Volt

The following connection, with the voltage change-over board set into the 240V set position (See Figure 19), can offer **THREE PHASE** power at 240V. After hooking up the hard wires to the lugs as shown in figure 20 below, 240V will be the voltage output.

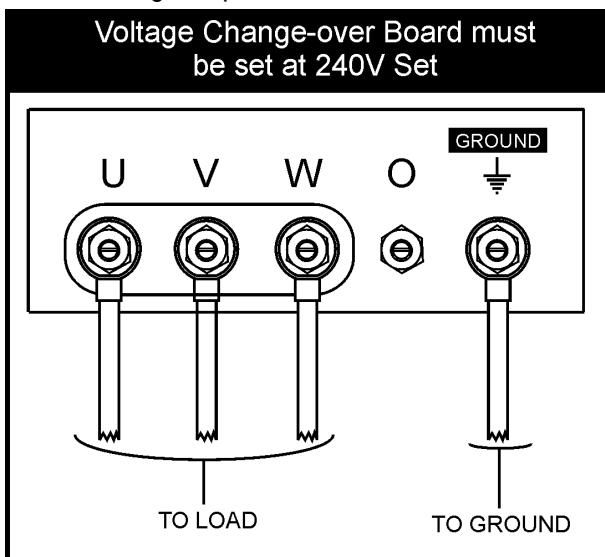

FIGURE 20. Hard Wire Hookup for Three Phase 240V

Single Phase, 240 Volt

The following connection, with the voltage change-over board set into the 240V set position (See Figure 19), can offer **SINGLE PHASE** power at 240V. After hooking up the hard wires to the lugs as shown in figure 21 below, 240V will be the voltage output.

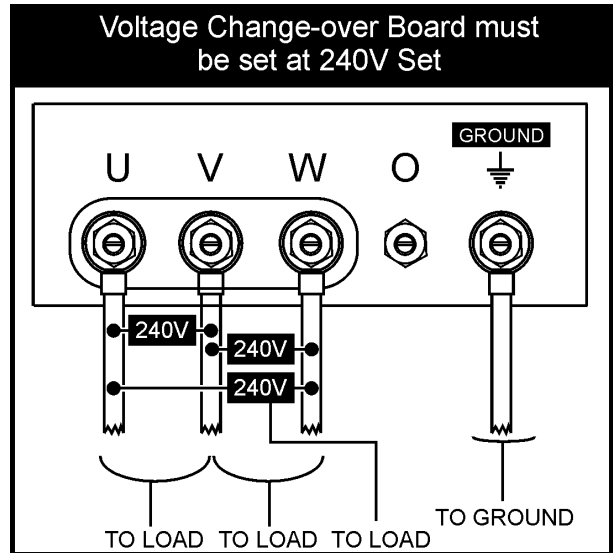

FIGURE 21. Hard Wire Hookup for Single Phase 240V

Single Phase, 139 Volt

The following connection, with the voltage change-over board set into the 240V set position (See Figure 19), can offer **SINGLE PHASE** power at 139V. After hooking up the hard wires to the lugs as shown in figure 22 below, 139V will be the voltage output.

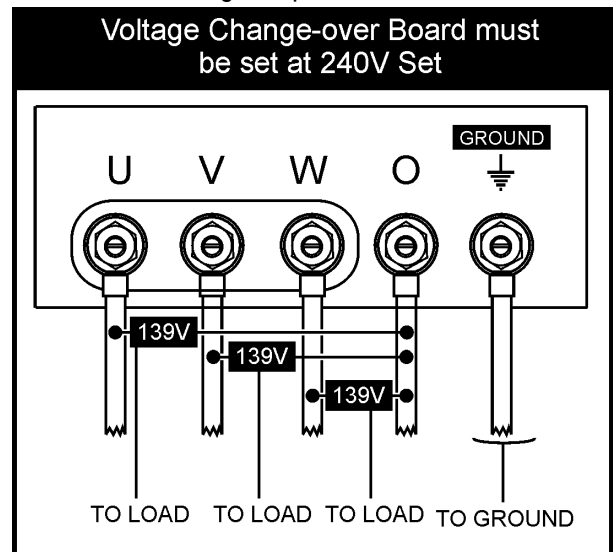

FIGURE 22. Hard Wire Hookup for Single Phase 139V

DCA-180SSK — OUTPUT TERMINAL PANEL OVERVIEW

480 Volt Set position

The voltage change-over board 480V set position uses all 6 plates in 3 different connection places. There are 2 plates at every position (Every plate is used). See figure 23 below.

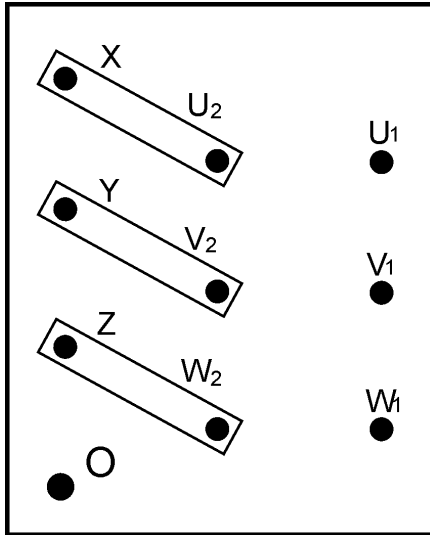

FIGURE 23. Voltage Change-over Board 480V set position.

3 Phase, 480Volt

The following connection, with the voltage change-over board set into the 480V set position (See Figure 23), can offer **THREE PHASE** power at 480V. After hooking up the hard wires to the lugs as shown in figure 24 below, 480V will be the voltage output.

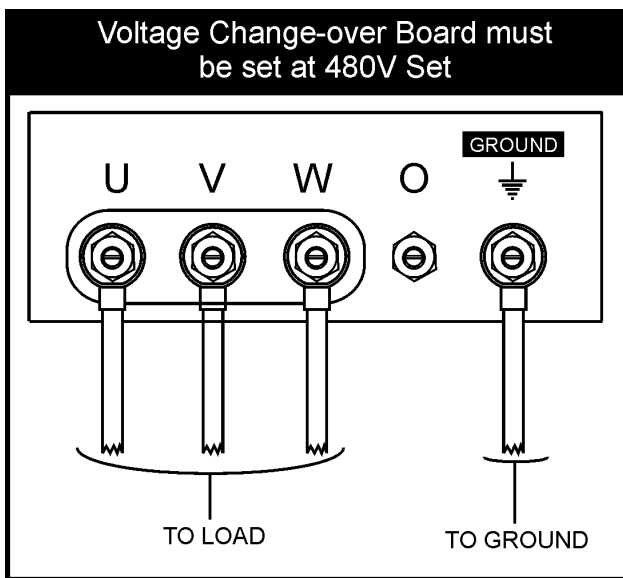

FIGURE 24. Hard Wire Hookup for Three Phase 480V

Single Phase, 480 Volt

The following connection, with the voltage change-over board set into the 480V set position (See Figure 23), can offer **SINGLE PHASE** power at 480V. After hooking up the hard wires to the lugs as shown in figure 25 below, 480V will be the voltage output.

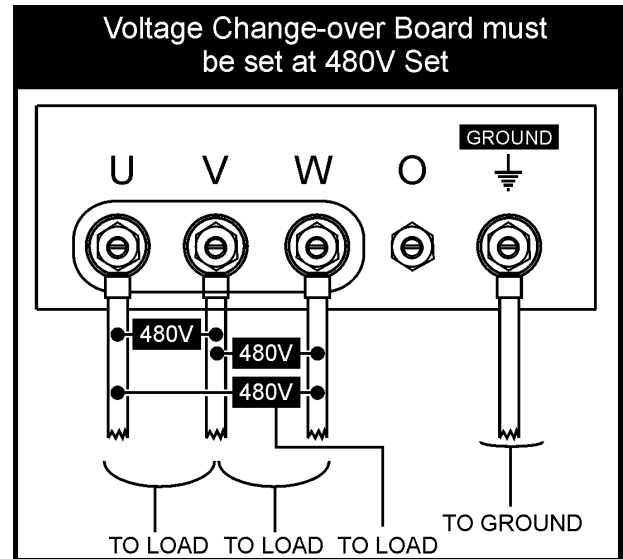

FIGURE 25. Hard Wire Hookup for Single Phase 480V

Single Phase, 277 Volt

The following connection, with the voltage change-over board set into the 480V set position (See Figure 23), can offer **SINGLE PHASE** power at 277V. After hooking up the hard wires to the lugs as shown in figure 26 below, 277V will be the voltage output.

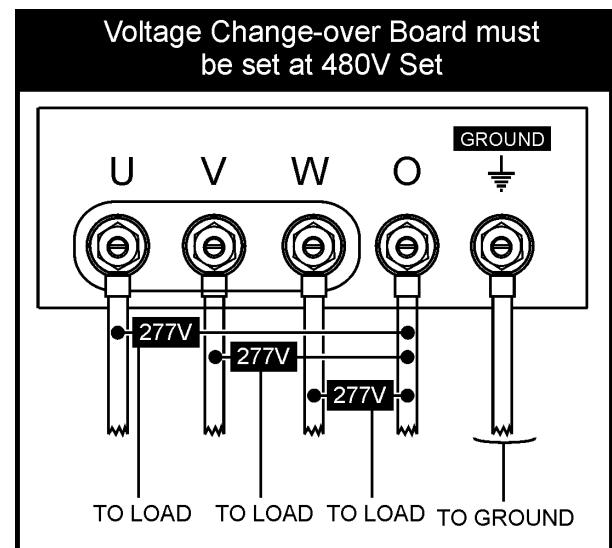

FIGURE 26. Hard Wire Hookup for Single Phase 277V

Outdoor Installation

Install the generator in a location where it will not be exposed to rain or sunshine. Make sure the generator is on secure level ground so that it cannot slide or shift around. Also install the generator in a manner so the exhaust will not be discharged in the direction of nearby homes.

The installation site must be relatively free from moisture and dust. All electrical equipment should be protected from excessive moisture. Failure to do will result in deterioration of the insulation and will result in short circuits and grounding.

Foreign materials such as dust, sand, lint and abrasive materials have a tendency to cause excessive wear to the engine parts and the alternator.

CAUTION :



Pay close attention to ventilation when operating the generator inside tunnels and caves. The engine exhaust contains noxious elements. Engine exhaust must be routed to a ventilated area.

Indoor Installation

Exhaust gases from diesel engines are extremely poisonous. Whenever an engine is installed indoors the exhaust fumes must be vented to the outside. The engine should be installed at least two feet from any outside wall. Using an exhaust pipe which is too long or too small can cause excessive back pressure which will cause the engine to heat excessively and possibly burn the valves.

CAUTION :



An electric shock may happen when vibrators are used. Pay close attention to handling when operating vibrators and always use rubber boots and gloves to insulate the body from electrical shock.

Generator Grounding

To guard against electrical shock and possible damage to the equipment, it is important to provide a good **EARTH** ground.

Article 250 (Grounding) of the National Electrical Code (NEC) provides guide lines for proper grounding and specifies that the cable ground shall be connected to the grounding system of the building as close to the point of cable entry as practical.

NEC articles 250-64(b) and 250-66 set the following grounding requirements:

1. Use one of the following wire types to connect the generator to earth ground.
 - a. Copper - 10 AWG (5.3 mm²) or larger.
 - b. Aluminum - 8 AWG (8.4 mm²) or larger.
2. When grounding the generator (Figure 27) connect the ground cable between the lock washer and the nut on the generator and tighten the nut fully. Connect the other end of the ground cable to earth ground.
3. NEC article 250-52(c) specifies that the earth ground rod should be buried a minimum of 8 ft. into the ground.

NOTE

When connecting the generator to any buildings electrical system **ALWAYS** consult with a licensed electrician.

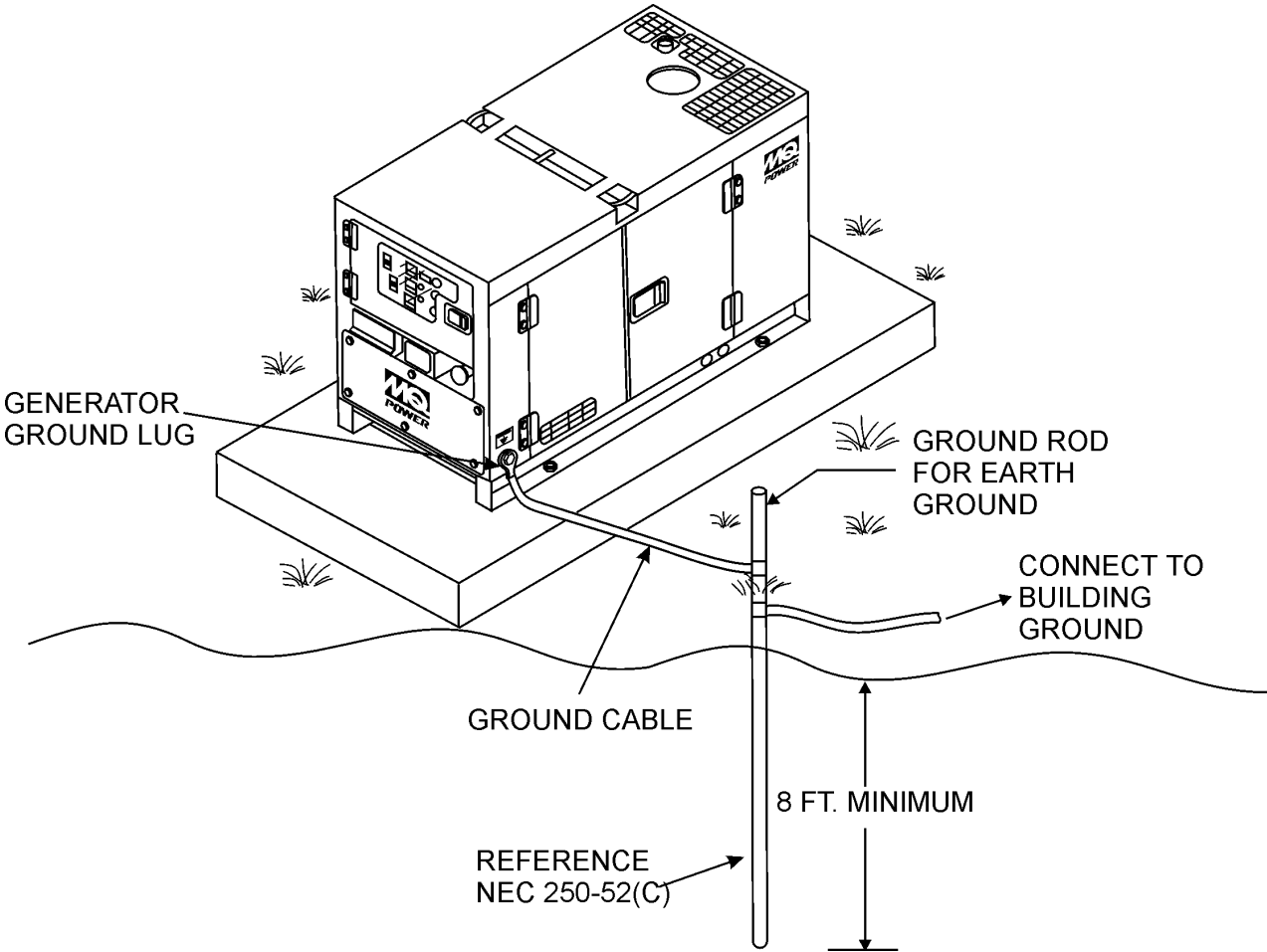

Figure 27. Typical Generator Grounding Application

General Inspection Prior to Operation

The DCA-180SSK generator has been thoroughly inspected and accepted prior to shipment from the factory. However, be sure to check for damaged parts or components, or loose nuts and bolts, which could have occurred in transit.

Extension Cable

When electric power is to be provided to various tools or loads at some distance from the generator, extension cords are normally used. Cables should be sized to allow for distance in length and amperage so that the voltage drop between the generator and point of use (load) is held to a minimum. Use the Cable Selection Guide (Table 10) as a guide for selecting proper cable size.

Circuit Breakers

To protect the generator from an overload, a 3-pole, 500 amp, **main** circuit breaker is provided to protect the UVW output terminals from overload. In addition two single-pole, 20 amp **GFCI** circuit breakers are provided to protect the GFCI receptacles from overload. Three 50 amp **load** circuit breakers have also been provided to protect the load side of the generator from overload. Make sure to switch **ALL** circuit breakers to the "OFF" position prior to starting the engine.

NOTE

ALWAYS consult with a licensed electrician for correct extension cord wire size.

Table 10. Cable Selection (60 Hz, Single Phase Operation)

Current in Amperes	Load In Watts		Maximum Allowable Cable Length			
	At 120 Volts	At 240 Volts	#10 Wire	#12 Wire	#14 Wire	#16 Wire
2.5	300	600	1000 ft.	600 ft.	375 ft.	250 ft.
5	600	1200	500 ft.	300 ft.	200 ft.	125 ft.
7.5	900	1800	350 ft.	200 ft.	125 ft.	100 ft.
10	1200	2400	250 ft.	150 ft.	100 ft.	
15	1800	3600	150 ft.	100 ft.	65 ft.	
20	2400	4800	125 ft.	75 ft.	50 ft.	
CAUTION: Equipment damage can result from low voltage.						

Lubrication Oil

Fill the engine crankcase with lubricating oil through the filler hole, but do not overfill. Make sure the generator is level. With the dipstick inserted all the way, but without being screw into the filler hole, verify that the oil level is maintained between the two notches (Figure 28) on the dipstick. See Table 11 for proper selection of engine oil.

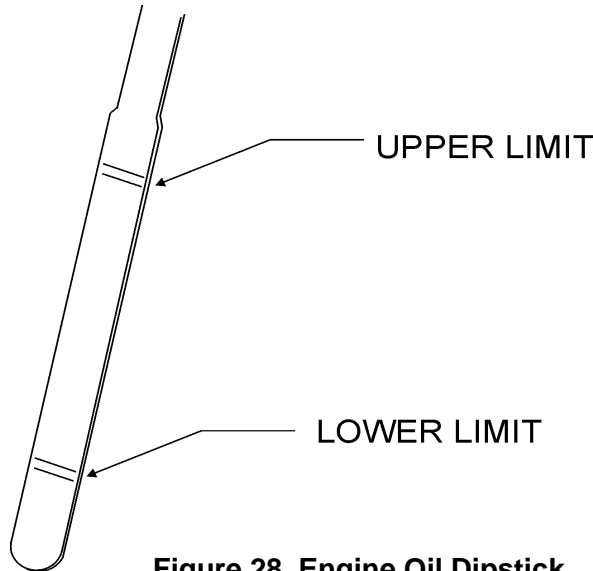

Figure 28. Engine Oil Dipstick

When checking the engine oil, be sure to check if the oil is clean and viscous. If the oil is not clean, drain the oil by removing the oil drain plug, and refill with the specified amount of oil as outlined in the **Komatsu Engine Owner's Manual**.

Fuel

Pay attention to the fuel tank capacity when replenishing fuel. Fill the fuel tank with clean and fresh **diesel fuel**. **DO NOT** fill the tank beyond capacity.

The fuel tank cap must be closed tightly after filling. Handle fuel in a safety container. If the container does not have a spout, use a funnel. Wipe up any spilled fuel immediately.

CAUTION :



Never fill the fuel tank while the engine is running or in the dark. Diesel fuel spillage on a hot engine can cause a fire or explosion. If diesel fuel spillage occurs, wipe up the spilled fuel completely to prevent fire hazards.

Coolant

Use only drinkable tap water. If hard water or water with many impurities is used, the inside of the engine and radiator may become coated with deposits and cooling efficiency will be reduced.

An anticorrosion additive added to the water will help prevent deposits and corrosion in the cooling system. See the engine manual for further details.

Table 11. Recommended Motor Oil

Temperature Range	Type Oil
104° F ~ 23° F (40° C ~ -5°C)	SAE 30
23° F ~ 5° F (-5° C ~ -15°C)	SAE 20 or SAE 10W-30
Below 5° C (-15°)	SAE 10W or SAE 10W-30

CAUTION :



When adding coolant or antifreeze to the radiator, do not remove the radiator cap until the unit has completely cooled.

Day-to-day addition of coolant is done from the reserve tank. When adding coolant to the radiator, **DO NOT** remove the radiator cap until the unit has completely cooled. See Table 12 for engine, radiator, and reserve tank coolant capacities. Make sure the coolant level in the reserve tank is always between the "H" and the "L" markings.

Table 12. Coolant Capacity

Engine and Radiator	7.4 Gal. (28 Liters)
Reserve Tank	2 Quarts (1.9 Liters)

Operation in Freezing Weather

When operating in freezing weather, be certain the proper amount of antifreeze (Table 13) has been added.

Table 13. Anti-Freeze Operating Temperatures

Vol % Anti-Freeze	Freezing Point		Boiling Point	
	°C	°F	°C	°F
40	-24	-12	106	222
50	-37	-34	108	226

NOTE

When the antifreeze is mixed with water, the antifreeze mixing ratio must be less than 50%.

Cleaning the Radiator

The engine may overheat if the radiator fins become overloaded with dust or debris. Periodically clean the radiator fins with compressed air. Cleaning inside the machine is dangerous, so clean only with the engine turned off and the battery disconnected.

Air Cleaner

Periodic cleaning/replacement is necessary. See maintenance section for instruction to cleaning/replacing air cleaner.

Fan Belt Tension

A slack fan belt may contribute to overheating, or to insufficient charging of the battery. Inspect the fan belt for damage and wear. See maintenance section on replacing belts. To adjust tension:

1. Insert a bar between alternator and the cylinder block to fix alternator in position. When fixing the alternator in position, insert a wooden block between the bar and alternator to prevent damage to the alternator.
2. Loosen bolts and nuts located on the alternator.
3. Move alternator with the bar so the deflection of the belt is approx. 8mm.
4. Tighten the bolt and nuts to fix the alternator back to position.

The fan belt tension is proper if the fan belt bends 7 to 10 mm (Figure 29) when depressed with the thumb as shown below.

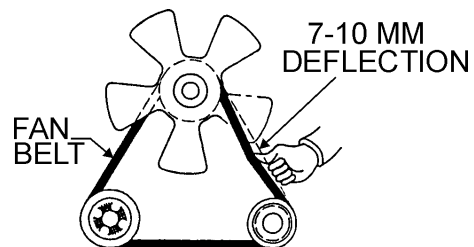

Figure 29. Fan Belt Tension

CAUTION :



Never place hands near the belts or fan while the generator set is running.

Battery Cable Installation

ALWAYS be sure the battery cables (Figure 30) are properly connected to the battery terminals as shown below. The **RED** cable is connected to the positive terminal of the battery, and the **BLACK** cable is connected to the negative terminal of the battery.

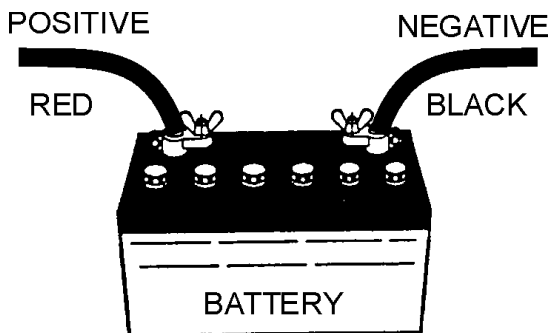

Figure 30. Battery Connections

CAUTION :



If the battery cable is connected incorrectly, electrical damage to the generator will occur. Pay close attention to the polarity of the battery when connecting the battery.

When connecting battery do the following:

1. **DO NOT** connect the battery cables to the battery terminals when the **Off/Manual/Auto** switch is in either the manual or auto position (ON). **ALWAYS** make sure that the Off/Manual/Auto switch is in the OFF position when connecting the battery..
2. Place a small amount of grease around both battery terminals. This will ensure a good connection and will help prevent corrosion around the battery terminals.

CAUTION :



Inadequate battery connections may cause poor starting of the generator, and create other malfunctions.

Wiring

Inspect the entire generator for bad or worn electrical wiring or connections. If any wiring or connections are exposed (insulation missing) replace wiring immediately.

Piping and Hose Connection

Inspect all piping, oil hose, and fuel hose connections for wear and tightness. Tighten all hose clamps and check hoses for leaks.

If any hose (fuel or oil) lines are defective replace them immediately.

Battery

This unit is of negative ground **DO NOT** connect in reverse. Always maintain battery fluid level between the specified marks. Battery life will be shortened, if the fluid level is not properly maintained. Add only distilled water when replenishment is necessary.

The battery is sufficiently charged if the specific gravity of the battery fluid is 1.28 (at 68°F). If the specific gravity should fall to 1.245 or lower, it indicates the battery is discharged and needs to be recharged or replaced.

Check to see whether the battery cables are loose. Poor contact may result in poor starting or malfunctions. Always keep the terminals firmly tightened. Coating the terminals with a thin film of grease will help inhibit corrosion.

Single Phase Load

Always be sure to check the nameplate on the generator and equipment to insure the wattage, amperage and frequency requirements are satisfactorily supplied by the generator for operating the equipment.

Generally, the wattage listed on the nameplate of the equipment is its rated output. Equipment may require 130—150% more wattage than the rating on the nameplate, as the wattage is influenced by the efficiency, power factor and starting system of the equipment.

NOTE

If wattage is not given on the equipment's name plate, approximate wattage may be determined by multiplying nameplate voltage by the nameplate amperage.

$$\text{WATTS} = \text{VOLTAGE} \times \text{AMPERAGE}$$

The power factor of this generator is 0.8. See Table 14 below when connecting loads.

Table 14. Power Factor By Load

Type Of Load	Power Factor
Single-phase induction motors	0.4 - 0.75
Electric heaters, incandescent lamps	1.0
Fluorescent lamps, mercury lamps	0.4 - 0.9
Electronic devices, communication equipment	1.0
Common power tools	0.8

Three Phase Load

When calculating the power requirements for 3-phase power use the following equation:

$$\text{KVA} = \frac{\text{VOLTAGE} \times \text{AMPERAGE} \times \sqrt{3}}{1000}$$

NOTE

If output (kVA) is not given on the equipment nameplate, approximate output may be determined by multiplying voltage by amperage by $\sqrt{3}$.

CAUTION:



Motors and motor-driven equipment draw much greater current for starting than during operation.

An inadequate size connecting cable which cannot carry the required load can cause a voltage drop which can burn out the appliance or tool and overheat the cable.

- When connecting a resistance load such as an incandescent lamp or electric heater, a capacity of up to the generating set's rated output (kW) can be used.
- When connecting a fluorescent or mercury lamp, a capacity of up to the generating set's rated output (kW) multiplied by 0.6 can be used.
- When connecting an electric drill or other power tools, pay close attention to the required starting current capacity.

When connecting ordinary power tools, a capacity of up to the generating set's rated output (kW) multiplied by 0.8 can be used.

CAUTION:



Before connecting this generator to any building's electrical system, a licensed electrician must install an isolation (transfer) switch. Serious injury or death may result without this transfer switch.

DCA-180SSK — GENERATOR START-UP PROCEDURE (MANUAL)

WARNING:



The engine's exhaust contains harmful emissions. **ALWAYS** ventilate the exhaust when operating inside tunnels, excavations or buildings. Direct exhaust away from nearby personnel.

Before Starting Engine

1. Check the lubricating oil level prior to starting the engine. Make sure the generator is level. The oil level must be maintained between two notches on the dipstick.
2. When there is not enough lubricating oil, fill the crankcase with high grade motor oil. Use a high quality detergent oil classified CC or higher (See Table 9 on page 39).
3. Check the coolant level in the radiator and subtank. Replenish with antifreeze as necessary. Always maintain the coolant level between the **FULL** and **LOW** markings on the coolant container. Be sure the radiator cap is fastened securely.
4. Check the fuel level on the fuel gauge. If fuel is low, fill the fuel tank with clean fresh diesel fuel. If fuel spillage occurs, completely wipe up the spilled fuel immediately.

Before Starting

Generator and Control Panel

CAUTION:



- **NEVER** start the engine with the **main, GFCI** or **load** circuit breakers in the **ON** position.

1. Be sure to disconnect the electrical load and switch the **main, load** and **G.F.C.I.** circuit breakers (Figure 31) to the "OFF" position prior to starting the engine.

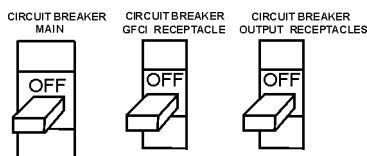

Figure 31. Main, GFCI and Load Circuit Breakers

Jacket Water Heater and Internal Battery Charger 120 VAC Output Receptacles (OPTIONAL)

This generator is equipped with two 120 VAC, 20 amp output receptacles located on the output terminal panel, page 35 Figure 14.

The purpose of these receptacles is to provide power via commercial power to the jacket water heater and internal battery charger.

These receptacles will **ONLY** function when commercial power has been supplied to them (Figure 32). To apply commercial power to these receptacles, a power cord of adequate size will be required.

When using the generator in **hot** climates there is no reason to apply power to jacket water heater. However, if the generator will be used in **cold** climates it is always a good idea to apply power to the jacket water heater at all times. To apply power to the jacket water heater simply apply power to the jacket water heater receptacle via commercial power using an power cord of adequate size.

If the generator will be used daily, the battery should normally not require charging. If the generator will be idle (not used) for long periods of time, apply power to the battery charger receptacle via commercial power using an power cord of adequate size.

When connecting the generator to a isolation (transfer) switch, **ALWAYS** have power applied to the generator's internal battery charger. This will ensure that the engine will not fail due to a dead battery.

CAUTION:



ALWAYS have power applied to the generator's internal battery charger when connecting the generator to a isolation (transfer) switch. Remember before connecting this generator to any buildings electrical system, have a **licensed** electrician perform the installation of the transfer switch.

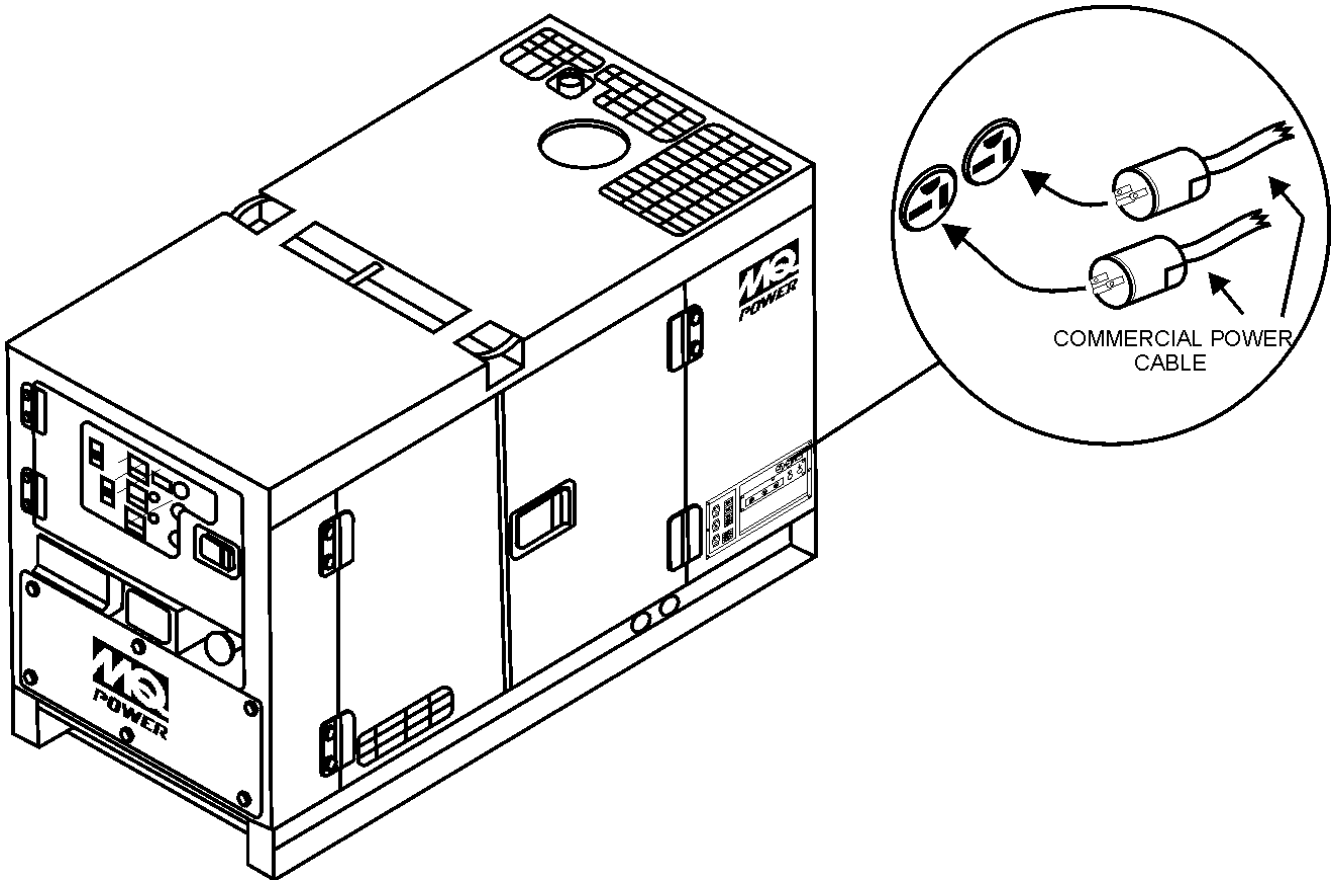

Figure 32. 120 VAC Accessory Receptacle/Cable

2. Once it is determined if commercial power is required, connect the load to the UVW terminals as shown in Figure 33. These terminals can be found on the output terminal panel, see page 35, Figure 14. To gain access to the output terminals lift the UVW cover. Make sure to tighten terminal nuts securely to prevent load wires from slipping out.
3. Connect the negative battery cable (BLACK) to the negative post on the battery (Figure 34).

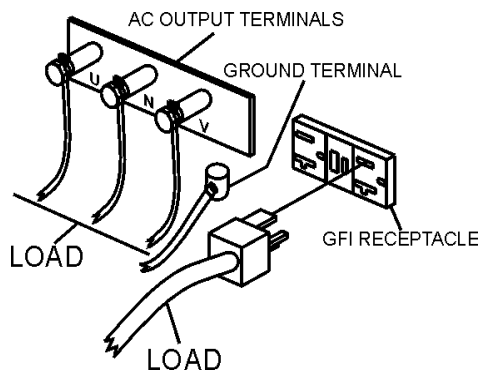

Figure 33. UVW Terminal Lugs (Load)

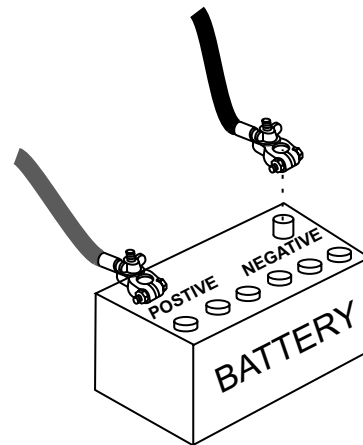

Figure 34. Battery Connections

DCA-180SSK — GENERATOR START-UP PROCEDURE (MANUAL)

4. Close all engine enclosure doors (Figure 35).

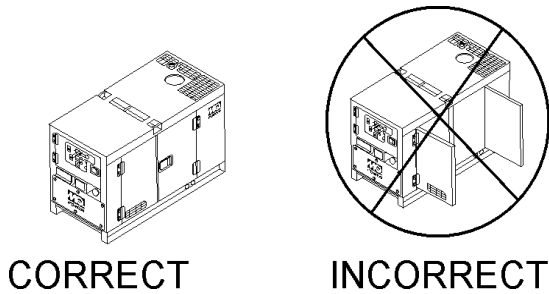

Figure 35. Engine Enclosure Doors

5. Set the battery switch to "ON" (Figure 36).

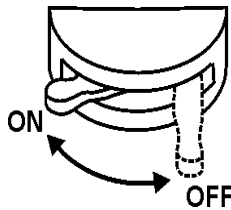

Figure 36. Battery ON/OFF Switch

6. Make sure the engine switch is on "LOW" (Figure 37).

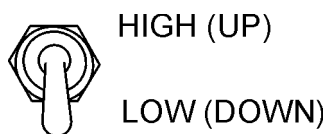

Figure 37. Engine Speed Switch

7. When starting the generator in **COLD** weather conditions, press and hold the engine preheat button (Figure 38) until the preheat lamp (Figure 39) is lit (ON).



Figure 38. Engine Pre-Heat Button



Figure 39. Engine Pre-Heat Lamp

8. Place the Off/Manual/Auto switch (Figure 40) in the **MANUAL** position (down). Observe that the engine begins to crank.

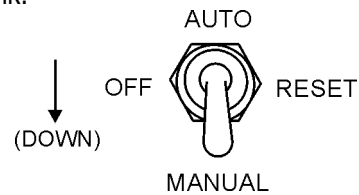

Figure 40. Off/Manual/Auto Switch (Manual)

9. After engine starts, verify that the "Engine Running" status LED (Figure 41) on the Microprocessor Engine Control Module (MPEC) display is "ON" (lit).



Figure 41. MPEC Engine Running Status LED

10. If the generator is equipped with a ignition switch, turn the key to "Start" position (Figure 42). Once the engine starts, release the key to the "on" position.

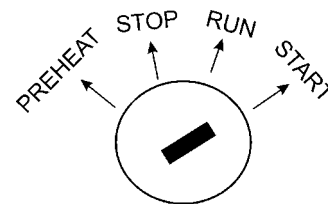

Figure 42. Engine Ignition Switch

DCA-180SSK — GENERATOR START-UP PROCEDURE (MANUAL)

11. The generator's frequency meter (Figure 43) displays the 60 cycle output frequency in **HERTZ**.

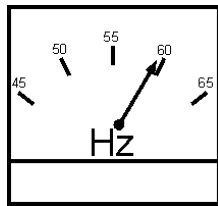

Figure 43. Frequency Meter (Hz)

12. The generator's voltage meter (Figure 44) displays the 120 VAC in **VOLTS**. If the voltage is not within the specified frequency tolerance, use the voltage adjustment control knob (Figure 45) to increase or decrease the desired voltage.

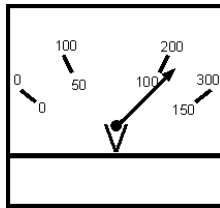

Figure 44. Voltage Meter (Volts)

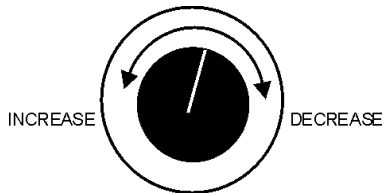

Figure 45. Voltage Adjust Control Knob

13. The ammeter (Figure 46) will indicate zero amps with no load applied. When a load is applied, this meter will indicate the amount of current that the load is drawing from the generator's alternator.

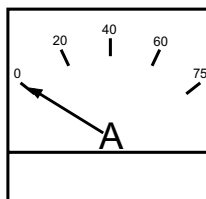

Figure 46. Ammeter (No Load)

14. The engine oil pressure gauge (Figure 47) will indicate the oil pressure (kg/ cm²) of the engine. Under normal operating conditions the oil pressure should be approximately 25 psi.

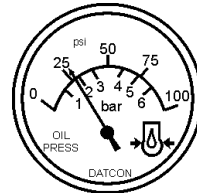

Figure 47. Oil Pressure Gauge

15. The coolant temperature gauge (Figure 48) will indicate the coolant temperature. Under normal operating conditions the coolant temperature should be between 105 and 215 degrees Fahrenheit (Green Zone).

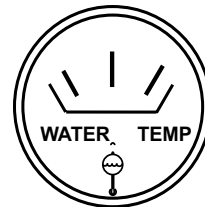

Figure 48. Coolant Temperature Gauge

16. Set the engine speed switch (Figure 49) to low to idle engine, set to high when a load is being applied.

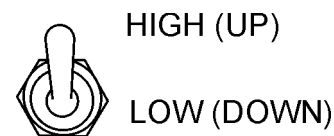

Figure 49. Engine Speed Switch

DCA-180SSK — GENERATOR START-UP PROCEDURE (MANUAL)

17. The tachometer (Figure 50) will indicate the speed of the engine when the generator is operating. Under normal operating conditions this speed should be approximately 1800 RPM's.

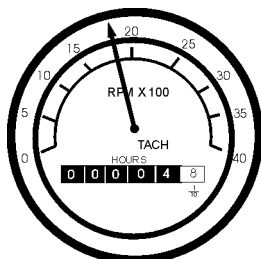

Figure 50. Engine Tachometer

18. If the engine speed is too high or low, use the high idle adjust trimmer (Figure 51) located on the control box to adjust the rated speed of the engine

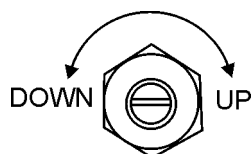

Figure 51. Engine Idle Adjust Trimmer

19. After the engine has been running for a few minutes, look at the status LED'S on the "MPEC" display (Figure 41) and check it for any abnormal conditions. If any abnormal conditions exist, take corrective action to solve the problem.
20. If there are no abnormal problems shown on the "MPEC" LED display, turn the MAIN, GFCI and LOAD circuit breakers to their ON position (Figure 52).

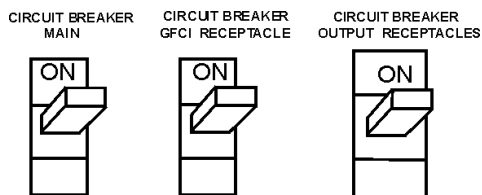

Figure 52. Main and GFCI Circuit Breakers

21. Observe the generator's ammeter (Figure 53) and verify that it reads the anticipated amount of current with respect to the load. Remember the ammeter will only display a current reading if the load is in use.

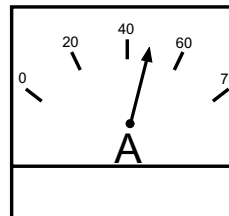

Figure 53. Ammeter (Load)

22. The generator will run until manually stopped or an abnormal condition occurs.

DCA-180SSK — GENERATOR START-UP PROCEDURE (AUTO)

CAUTION:



Before connecting this generator to any building's electrical system, a **licensed electrician** must install an isolation (transfer) switch. Serious ***injury*** or ***death*** may result without this transfer switch.

CAUTION:



When connecting the generator to a isolation (transfer) switch, **ALWAYS** have power applied to the generator's internal battery charger. This will ensure that the engine will not fail due to a dead battery.

Starting the generator in the "AUTO" mode is similar to starting the generator in the "MANUAL" mode, with a few exceptions.

CAUTION:



When running the generator in the **AUTO** mode, remember the generator can start up at any time without warning. **NEVER** attempt to perform any maintenance when the generator is in the auto mode.

When starting generator in Auto mode use the "Manual Start-up" procedure except where noted (see below).

1. Perform steps 1 through 8 (See page 47-49) as outlined in the manual starting procedure.
2. Apply commercial power to the internal battery charger receptacle (to ensure good starting) via commercial power. An external power cord will be required.
3. Apply commercial power to the jacket water heater receptacle (not necessary for warm climates) via commercial power. An external power cord will be required.
4. Place the Off/Manual/Auto switch (Figure 54) in the **AUTO** position (up).

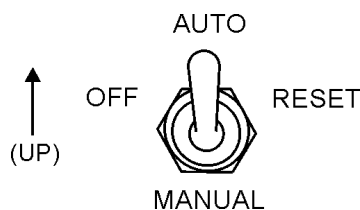

Figure 54. Off/Manual Auto Switch (AUTO)

5. Continue to follow the steps outline in the manual start-up procedure (start at step 11, page 50).

DCA-180SSK — GENERATOR SHUTDOWN PROCEDURE

Engine Shutdown

To shutdown the generator use the following procedure:

1. Place both the **MAIN**, **GFCI** and **LOAD** circuit breakers to the "OFF position".
2. Set the engine speed switch (Figure 55) to the idle (low) position.

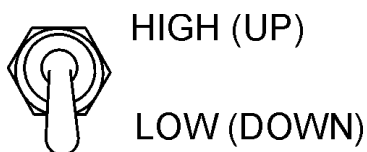

Figure 55. Engine Speed Switch

3. Let the engine cool by running it for 3-5 minutes with no load applied.
4. Place the Off/Manual/Auto Switch (Figure 56) in the "OFF/RESET" position

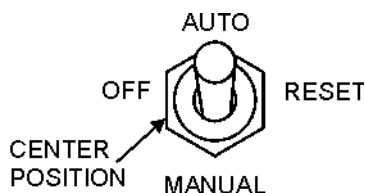

Figure 56. Off/Manual Auto Switch (OFF)

5. Verify that the "Engine Running" status LED (Figure 57) on the Microprocessor Engine Control Module (MPEC) display is "OFF" (not lit).

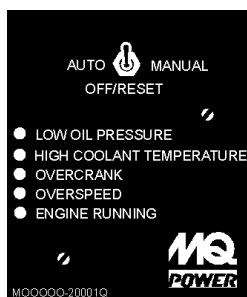

Figure 57. MPEC Engine Running Status LED (OFF)

6. Remove the load from the UVWO terminal strip (Figure 14 on page 35).

Emergency Stop

1. To stop the engine in the event of an emergency, **PUSH** the emergency stop button (Figure 58) inward. This button is located on the generator's engine operating panel, see page 32, Figure 10.

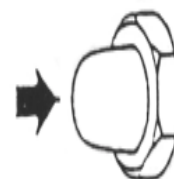

Figure 58. Emergency Stop Button

CAUTION:



NEVER stop the engine suddenly except in an emergency. **DO NOT** use the emergency stop switch as a method of shutting down the engine. This switch is **ONLY** to be used in the event of an emergency.

General Inspection

Prior to each use, the generating set should be cleaned and inspected for deficiencies. Check for loose, missing or damaged nuts, bolts or other fasteners. Also check for fuel or oil leaks.

Air Cleaner

Every 50 hours: If dust indicator is red, clean the air cleaner element.

Outer Element:

1. Loosen wing bolt, remove dust cup, then remove wing nut and take out element.
2. Clean the inside of the body and cover using a damp cloth.
3. Blow dry with compressed air (0.69Mpa {7kgf.cm², 99.4 PSI} maximum against the side of the element along the pleats. Then blow dry against outside along the pleats, then against inside again.
4. Remove one seal each time the element is cleaned.
5. Replace the outer element after cleaning it 6 times or after one year. Replace the outer element if indicator is red even after cleaning it.
6. Check the inner cylinder element clamping nut for looseness, and retighten if necessary.
7. If seal washer is damaged or the threads of wing nut are damaged, replace.
8. Remove evacuator valve and clean it with compressed air. Reinstall.

Inner element (if equipped)

1. Remove the cover and outer element, then remove the inner element.
2. Cover the air connector opening (outer side) with clean cloth or cloth tape.
3. Clean the inside of the body. Remove air connector opening protection.
4. Install a new inner cylinder element to the cylinder and tighten the nut.
5. Install element.
6. After replacing the element, press the button of the dust indicator to return the red piston to its original position.

Fuel Addition

Add diesel fuel (the grade may vary according to season and locations). Always pour through the mesh filter.

Removing Water from the Tank

After prolonged use, water and other impurities accumulate in the bottom of the tank. Occasionally remove the drain cock and drain the contents. During cold weather, the greater the empty volume inside the tank, the easier it is for water to condense. This can be reduced by always keeping the tank as full as possible.

Air Removal

If air enters the fuel injection system of a diesel engine, starting becomes impossible. After running out of fuel, or after disassembling the fuel system, bleed the system according to the following procedure.

To restart after running out of fuel, turn the key switch to the "START" position for 15-30 seconds. Try again, if needed. This unit is equipped with an automatic air bleeding system.

Service Daily

If engine is operating in very dusty and dry grass conditions, a clogged air cleaner will result in high fuel consumption, loss of power and excessive carbon buildup in the combustion chamber.

Cleaning the Fuel Strainer

Clean the fuel strainer if it contains dust or water. Remove dust or water in the strainer cap and wash it in diesel. Securely fasten the fuel strainer cap so that fuel will not leak. Check the fuel strainer every 200 hours of operation or once a month.

Check Oil Level

Check the crankcase oil level prior to each use, or when the fuel tank is filled. Insufficient oil may cause severe damage to the engine. Make sure the generator is level. The oil level must be between the two notches on the dipstick as shown in Figure 28, page 43.

Flushing Out Radiator and Changing Coolant

1. Stop the engine and allow to cool. Tighten valve of the corrosion resistor (if equipped).
2. Turn water filler cap slowly and remove it.
3. Prepare a container to catch the coolant, then open drain plug of the radiator or heat exchanger and drain plug of the engine, and drain the coolant.
4. After draining the coolant, close drain plugs and fill with tap water.

5. When the water level is near the mouth of the water filler, open drain plugs and start the engine, and run at low idling. Keep the engine running at low idling and flush the radiator for about 10 minutes.
6. Adjust the flow of the water flowing in and draining out to ensure that the radiator is always full during the flushing operation, While flushing water through the system, watch carefully the water inlet hose does not come out of the radiator filler port.
7. After flushing, stop the engine, open drain plug and drain the water, then close drain plugs.
8. After draining the water, flush the system with a flushing agent. See instructions on flushing agent label.
9. After flushing, open drain plugs and drain out all the water, then close drain plugs and add tap water so the water level is near the mouth of the water filler.
10. When the water level is near the mouth of the water filler, open drain plugs and start the engine, run at low idling and continue to flush the system until clean water comes out. Adjust the flow of the water flowing in and draining out to ensure the radiator is always full during the flushing operation.
11. When clean water comes out, stop the engine, drain all the water, then close drain plugs.
12. Remove the corrosion resistor (if equipped) and open valve.
13. Supply water until it flows over the water filler.
14. Drain the water inside reserve tank, clean the inside of the reserve tank, then fill with coolant/water mixture to between the full and low lines.
15. Stop the engine, wait for 3 minutes, add tap water until the water level reaches near the water filler port, then tighten the radiator cap.

Check Electric Heater (If equipped)

Before starting in cold weather (once a year), please contact your Komatsu distributor for inspection. Remove electric heater from the engine intake manifold and check for disconnections or dirt. When checking or installing the electric heater, replace the gasket with a new part.

Changing Oil

1. Make sure the oil is cool before changing.
2. Set a container directly under the drain plug of the oil pan. Loosen the drain plug slowly.
3. Check the drained oil for excessive metal particles or foreign material. Contact the distributor if there is metal particles or foreign material.
4. Using a filter wrench, turn filter cartridge to the left to remove it. If the filter cartridge is filled with a large amount of oil, wait 10 minutes or so before removing. Make sure there is no old gasket stuck on the filter holder.
5. Tighten drain plug. Clean the filter holder, fill the new filter cartridge with clean engine oil, coat the packing and thread of the new filter cartridge with engine oil, then install it to the filter holder. Tighten until the gasket surface contacts the seal surface of the filter holder, then tighten it a further 3/4 to 1 turn.
6. Add engine oil through oil filler until the oil level is between the H and L marks on the dipstick.
7. Run the engine at idling for a short time, then stop the engine. Recheck the oil level and fill as necessary.

Replacing fuel filter

1. Set the container under the filter cartridge to catch fuel.
2. Using a filter wrench, turn the filter cartridge to the left to remove it.
3. Clean the filter holder, fill the new filter cartridge with fuel, coat the packing surface of the filter cartridge with engine oil, then install the cartridge to the filter holder.
4. When installing, tighten until the packing surface contacts the seal surface of the filter holder then tighten a further 2/3 of a turn. If the filter cartridge is tighten too much, the packing will be damaged and will cause fuel leakage. Fuel leakage will occur if the filter cartridge is not tightened enough. Always tighten to the correct angle.
5. After replacing filter cartridge, loosen air bleed plug.
6. Loosen the knob of feed pump, and pump it up and down until no bubbles come out with the fuel from air bleed plug.

7. After bleeding the air, tighten air bleed plug, then push in the knob of feed pump and lock it in position.
8. Replace Corrosion resistor cartridge (if equipped)
9. Screw in valves at the top of the corrosion resistor.
10. Using a filter wrench, turn the cartridge to the left to remove it.
11. Coat the seal surface of the new cartridge with engine oil and install it to the filter holder.
12. Tighten until the packing surface contacts the seal surface of the filter holder, then tighten a further 2/3 of a turn.
13. Open valves.

Cleaning breather element

1. Loosen the clamp, then remove the hose and take out breather. Wipe off the dirt around the breather. Check the O-ring, and replace if necessary.
2. Wash the breather in diesel fuel or flushing oil, blow dry with compressed air, then reinstall it.
3. Inspect the hose and if there is any deteriorated oil stuck inside the hose. Replace hose if necessary.

Greasing

Using a grease pump, grease the fan hub (1 place) and tension pulley (2 places).

Generator Storage

For storage of the generator for over 30 days, the following is required:

- Drain the fuel tank completely, lubricate and change oil.
- Disconnect the negative terminals of the battery and cover it, or remove it from the machine and store it separately.
- If the ambient temperature is expected to drop below 0°C, add antifreeze to the radiator.

Removal from long term storage:

- Apply oil to the engine valve and rocker arms, and examine the operating condition of the valves.
- remove the oil filler pipe from the turbocharger oil inlet port, add 0.5-1L (0.13-0.26gal) of oil to the turbocharger, reinstall the oil filler pipe.
- Change the oil in engine oil pan.
- Replace all the filters.
- Flush the inside of the cooling system.
- Drain the water from the fuel tank and bleed the air from the fuel system.
- If the engine has not been started for more than one year, contact your Komatsu distributor to have engine overhauled.

TABLE 15.

INSPECTION / MAINTENANCE		10 Hrs DAILY	250 Hrs	500 Hrs	1000 Hrs
ENGINE	Check Engine Fluid Levels	X			
	Check Air Cleaner	X			
	Check Battery Acid Level	X			
	Check Fan Belt Condition	X			
	Check for Leaks	X			
	Check for Loosening of Parts	X			
	Check Water Separator(if applicable)	X			
	Replace Engine Oil and Filter *1		X		
	Clean Air Filter		X		
	Drain Bottom of Fuel Tank		X		
	Clean Unit, Inside and Outside		X		
	Change Fuel Filter *2			X	
	Replace Water Separator Element *3		(X)	X	
	Clean Radiator and Check Coolant Protection Level			X	
	Replace Air Filter Element				X
	Change Corrosion Resistor				X
	Check all Hoses and Clamps				X
Clean Inside of Fuel Tank				X	
GENERATOR	Measure Insulation Resistance Over 3M ohms		X		

*1 Replace engine oil and filter at 100 hours, first time only.

*2 Replace fuel filter at 250 Hours, first time only.

*3 Refer to the item "Water Separator Filter".

DCA-180SSK — GENERATOR WIRING DIAGRAM

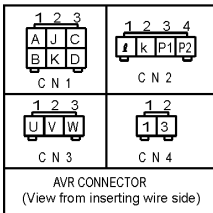
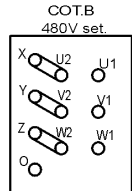
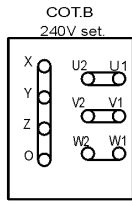
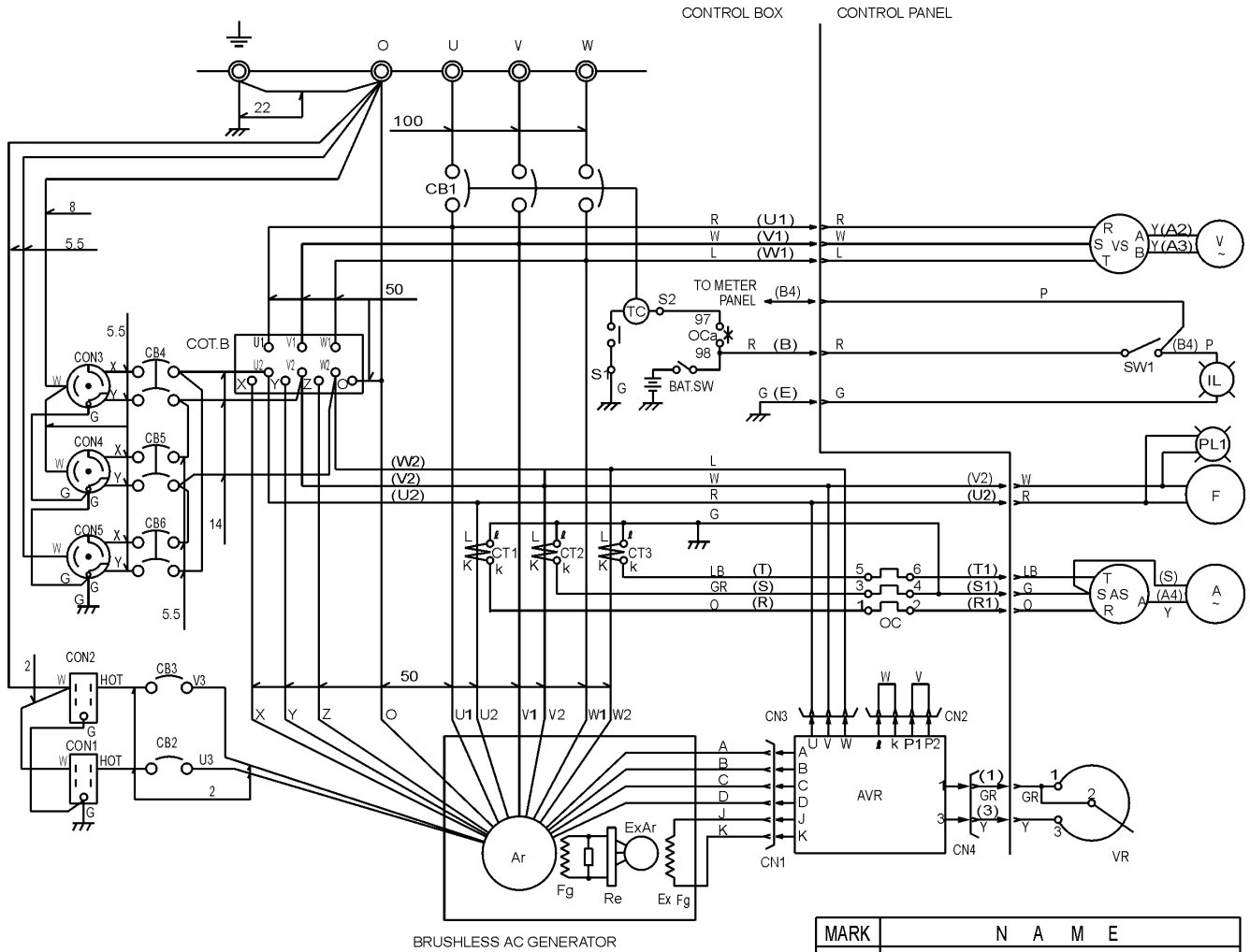

NO MARK: 1.25mm²

WIRE SIZE	COLOR CODE	
	WIRE COLOR	WIRE COLOR
100: 100mm ²	B	BLACK
50: 50mm ²	L	BLUE
38: 38mm ²	BR	BROWN
22: 22mm ²	G	GREEN
14: 14mm ²	GR	GRAY
8: 8mm ²	V	VIOLET
5.5: 5.5mm ²	P	PINK
2: 2mm ²		

CONTROL BOX SIDE		CONTROL PANEL SIDE	
1	2	4	3
3	4	2	1
E	W1	U1	
	1	U2	
B		3	V2
		1	2
		R1	S1
		T1	

CONNECTOR
(VIEW FROM INSERTING WIRE SIDE)

MARK	N A M E
Ar	MAIN GENERATOR ARMATURE WINDING
Fg	MAIN GENERATOR FIELD WINDING
ExAr	EXCITER ARMATURE WINDING
ExFg	EXCITER FIELD WINDING
AVR	AUTOMATIC VOLTAGE REGULATOR
VR	VOLTAGE REGULATING RHEOSTAT
Re	RECTIFIER
CT1-3	CURRENT TRANSFORMER 300/5A
CB1	CIRCUIT BREAKER 500A
OC	OVER CURRENT RELAY
COT.B	VOLTAGE CHANGE-OVER BOARD
AS	AMMETER CHANGE-OVER SWITCH
A	AC.AMMETER 0 300,600A
VS	VOLTMETER CHANGE-OVER SWITCH
V	AC.VOLTMETER 0 660V
F	FREQUENCY METER 45 65Hz
PL1	PILOT LAMP
CB2,3	AUX.CIRCUIT BREAKER 20A
CB4-6	AUX.CIRCUIT BREAKER 50A
CON1,2	AUX.POWER RECEPTACLE 20A
CON 4-6	AUX.POWER RECEPTACLE 50A
Re1	RECTIFIER
IL	PANEL LIGHT
SW1	PANEL LIGHT SWITCH

DCA-180SSK — ENGINE WIRING DIAGRAM

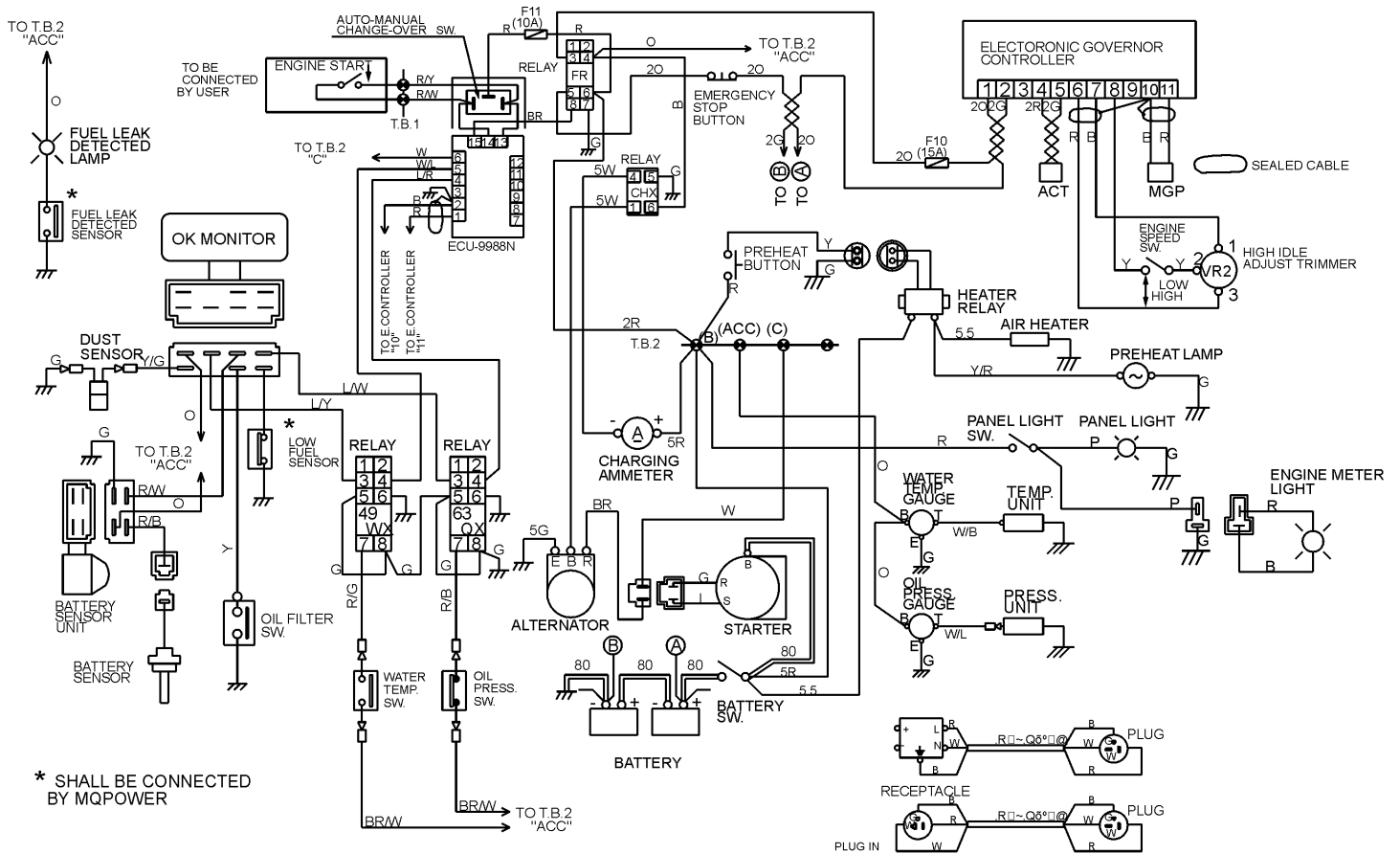

* SHALL BE CONNECTED BY MQPOWER

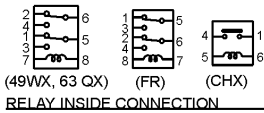

WIRE SIZE	COLOR CODE	
	WIRE COLOR	WIRE COLOR
100: 100mm ²		
38: 38mm ²	B BLACK	R RED
22: 22mm ²	L BLUE	W WHITE
14: 14mm ²	BR BROWN	Y YELLOW
5: 5mm ²	G GREEN	LB LIGHT BLUE
2: 2mm ²	GR GRAY	LG LIGHT GREEN
NO MARK WIRE SIZE	V VIOLET	O ORANGE
	P PINK	

DCA-180SSK — TROUBLESHOOTING (ENGINE)

Practically all breakdowns can be prevented by proper handling and maintenance inspections, but in the event of a breakdown, please take a remedial action following the

diagnosis based on the Engine Troubleshooting (Table 16) information shown below and on the preceding page. If the problem cannot be remedied, consult our company's business office or service plant.

TABLE 16. ENGINE TROUBLESHOOTING

SYMPTOM	POSSIBLE PROBLEM	SOLUTION
Engine does not start.	No fuel?	Replenish fuel.
	Air in the fuel system?	Bleed system.
	Water in the fuel system?	Remove water from fuel tank.
	Fuel pipe clogged?	Clean fuel pipe.
	Fuel filter clogged?	Clean or change fuel filter.
	Excessively high viscosity of fuel or engine oil at low temperature?	Use the specified fuel or engine oil.
	Fuel with low cetane number?	Use the specified fuel.
	Fuel leak due to loose injection pipe retaining nut?	Tighten nut.
	Incorrect injection timing?	Adjust.
	Fuel cam shaft worn?	Replace.
	Injection nozzle clogged?	Clean injection nozzle.
	Injection pump malfunctioning?	Repair or replace.
	Seizure of crankshaft, camshaft, piston, cylinder liner or bearing?	Repair or replace.
	Compression leak from cylinder?	Replace head gasket, tighten cylinder head bolt, glow plug and nozzle holder.
	Improper valve timing?	Correct or replace timing gear.
Piston ring and liner worn?	Replace.	
Excessive valve clearance?	Adjust.	
Starter does not run.	Starter malfunctioning?	Repair or replace.
	Wiring disconnected?	Connect wiring.

TABLE 16. ENGINE TROUBLESHOOTING (CONTINUED)

SYMPTOM	POSSIBLE PROBLEM	SOLUTION
Engine revolution is not smooth.	Fuel filter clogged or dirty?	Clean or change.
	Air cleaner clogged?	Clean or change.
	Fuel leak due to loose injection pipe retaining nut?	Tighten nut.
	Injection pump malfunctioning?	Repair or replace.
	Incorrect nozzle opening pressure?	Adjust.
	Injection nozzle stuck or clogged?	Repair or replace.
	Fuel over flow pipe clogged?	Clean.
	Governor malfunctioning?	Repair.
Either white or blue exhaust gas is observed.	Excessive engine oil?	Reduce to the specified level.
	Piston ring and liner worn or stuck?	Repair or replace.
	Incorrect injection timing?	Adjust.
	Deficient compression?	Adjust top clearance.
Either black or dark gray exhaust gas is observed.	Overload?	Lessen the load.
	Low grade fuel used?	Use the specified fuel.
	Fuel filter clogged?	Clean or change.
	Air cleaner clogged?	Clean or change.
	Deficient nozzle injection?	Repair or replace the nozzle.
Deficient output.	Incorrect injection timing?	Adjust.
	Engine's moving parts seem to be seizing?	Repair or replace.
	Uneven fuel injection?	Repair or replace the injection pump.
	Deficient nozzle injection?	Repair or replace the nozzle.
	Compression leak?	Replace head gasket, tighten cylinder head bolt, glow plug and nozzle holder.

DCA-180SSK — TROUBLESHOOTING (GENERATOR/ENGINE)

Practically all generator breakdowns can be prevented by proper handling and maintenance inspections, but in the event of a breakdown, please take a remedial action following the

diagnosed based on the Generator Troubleshooting (Table 17) and the MPEC troubleshooting (Table 18) information shown . If the problem cannot be remedied, consult our company's business office or service plant.

TABLE 17. ENGINE & GENERATOR TROUBLESHOOTING

SYMPTOM	POSSIBLE PROBLEM	SOLUTION
Engine fails to start and starter does not rotated.	Dead battery?	Replace battery.
	Defective starter switch?	Replace switch.
	Fuse F5 burned out?	Replace fuse.
Engine fails to start and starter rotates.	Broken pre-heat circuit?	Check pre-heat circuit.
	No fuel?	Add fuel.
	Defective wiring?	Check wiring.
Engine starts and remains at low speed.	Clogged fuel strainer?	Clean or replace.
	Clogged air cleaner?	Clean or replace.
	Disconnected wiring?	Check and repair wiring.
Engine speed rises and no voltage is present in AC power source.	No voltage present in AC power source?	Replace rectifier (RE1).
	Defective rotor?	Replace rotor.
	Defective voltmeter?	Replace voltmeter.
	Disconnected wiring?	Check and repair wiring.
	Layer short-circuit in armature winding?	Replace armature.
Engine speed rises and AC power voltage is too low or cannot be used.	Defective circuit breaker (protector)?	Replace circuit breaker (protector).
	Layer short-circuit, broken wires in armature winding?	Repair or replace armature.
Engine speed rises and battery discharges too soon.	Defective engine regulator?	Replace regulator.
	Defective wiring?	Repair or replace wiring.
Engine speed rises and engine seems overloaded.	Defective alternator?	Repair or replace alternator.
	Damaged alternator bearing?	Replace alternator bearings.

TABLE 18. MPEC TROUBLESHOOTING

Sympton	Possible Cause	Solution
Low oil pressure light is on.	Low oil level?	Fill oil level.
	Oil pressure sending unit failure?	Replace oil pressure sending unit.
	Time delay malfuntion in MPEC?	Refer to dealer.
	Wire shorted?	Inspect/repair wire.
Low coolant level light is on.	Low coolant level?	Fill coolant level.
	Sending unit failure?	Replace sending unit.
	Low battery voltage?	Replace/charge battery.
High coolant temperture light is on.	Fan belt tension incorrect?	Tighten/replace fan belt.
	Air flow is not circulation through radiator?	Clean/repair radiator grill.
	Doors open?	Close doors.
	Exhaust leaking?	Replace/repair gaskets or faulty part.
	Generator being overloaded?	Check/reduce load.
	Thermostat failure?	Replace thermostat.
	Air intake blocked?	Clear all air intakes.
	Temperature switch failure?	Replace temperature switch.
Overcrank light is on.	No or low Fuel?	Fill fuel level.
	MPEC needs to be calibrated?	Refer to dealer.
Overspeed light is on.	RPM engine speed too high?	Adjust RPM.
	Governor actuator needs to be adjusted?	Adjust governor actuator.
	Governor controller needs to be adjusted?	Adjust governor controller.
	MPEC needs to be calibrated?	Refer to dealer.
Loss of MPU light(s) or on.	Magnetic pick up out of adjustment?	Adjust magnetic pick up.
	Magnetic pick up dirty?	Clean magnetic pick up.

EXPLANATION OF CODE IN REMARKS COLUMN

How to read the marks and remarks used in this parts book.

Items Found In the “Remarks” Column

Serial Numbers-Where indicated, this indicates a serial number range (inclusive) where a particular part is used.

Model Number-Where indicated, this shows that the corresponding part is utilized only with this specific model number or model number variant.

Items Found In the “Items Number” Column

All parts with same symbol in the number column, *, #, +, %, or ■, belong to the same assembly or kit.

Note: If more than one of the same reference number is listed, the last one listed indicates newest (or latest) part available.

**DCA-180SSKW/KOMATSU SA6D108E-2
DIESEL ENGINE****1 OF 5 UNITS**

Qty.	P/N	Description
1	0601808262	CIRCUIT BREAKER
1	0601820625	AUTOMATIC VOLTAGE REGULATOR
1	0601840073	RHEOSTAT VOLTAGE REGULATOR
1	0601840121	KNOB RHEOSTAT
1	0602014594	RADIATOR HOSE
1	0602013977	RADIATOR HOSE
1	0602014645	RADIATOR HOSE
5	0602041147	OIL FILTER
5	0602042146	FUEL FILTER
5	0602046333	AIR ELEMENT
1	0602122251	UNIT OIL PRESSURE
1	0602123250	UNIT WATER PRESSURE
1	0601810244	BULB
1	0602102047	BULB
1	0601808507	TRANSDUCER WATT METER
1	412121761	FAN BELT

DCA-180SSK — GENERATOR ASSY.

GENERATOR ASSY.

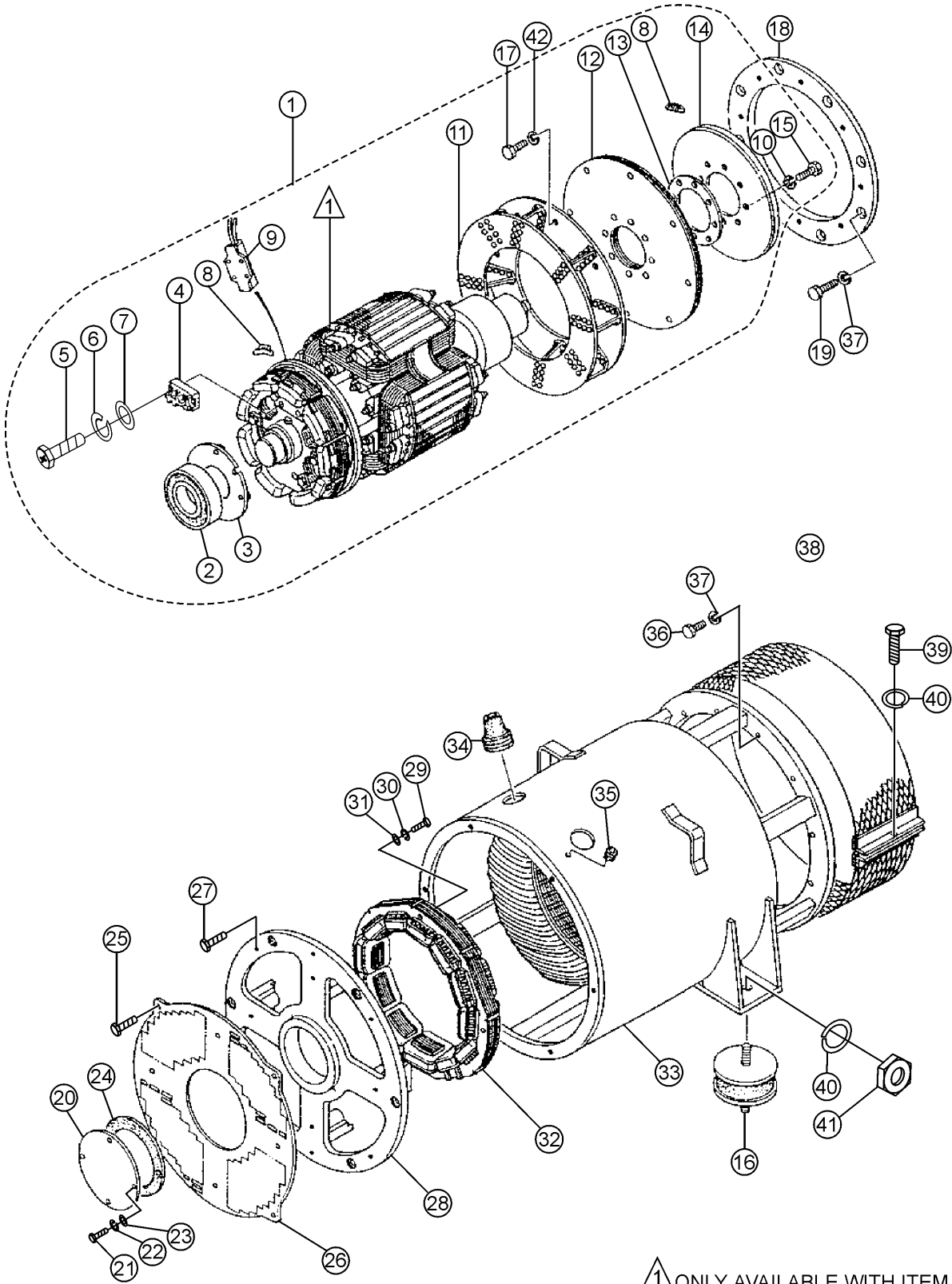

△ ONLY AVAILABLE WITH ITEM 1

DCA-180SSK — GENERATOR ASSY.

GENERATOR ASSY.

<u>NO</u>	<u>PART NO</u>	<u>PART NAME</u>	<u>QTY.</u>	<u>REMARKS</u>
1	C0110100102	ROTOR ASSEMBLY	1	INCLUDE ITEMS W/*
2*	0071906314	BEARING	1	6314 DDU C3
3*	C1112500004	BEARING FLANGE	1	
4*	0601823282	RECTIFIER	1	RM50TC-24
5*	0018205020	HEX. CAP SCREW	2	
6*	0040005000	LOCK WASHER	2	
7*	0041205000	PLAIN WASHER	2	
8*	0601000209	BALANCING WEIGHT KIT	1	
9*	0601842334	RESISTOR	1	SMRK 80W 100kS
10*	0042616000	LOCK WASHER	8	
11*	8171070002	FAN	1	
12*	8171611003	COUPLING DISK	9	
13*	C1164200004	WASHER, COUPLING HUB	1	
14*	81710-15003	BALANCING PLATE	1	
15	0012116045	HEX. HEAD BOLT	8	
16	06050-00012	RUBBER SUSPENSION	2	
17*	0012112040	HEX. HEAD BOLT	8	
18	8301614003	COUPLING RING	1	
19	0012112035	HEX. HEAD BOLT	8	
20	C1154400004	COVER, BEARING	1	
21	0010106060	HEX. HEAD BOLT	4	
22	0040006000	LOCK WASHER	4	
23	0041206000	PLAIN WASHER	5	
24	C1154300004	GASKET, BEARING	1	
25	0017106016	HEX. HEAD BOLT	8	
26	C1154400103	SUCTION COVER	1	
27	0017112045	HEX. HEAD BOLT	6	
28	C1154000002	END BRACKET	1	
29	0012110065	HEX. HEAD BOLT	4	
30	0042610000	LOCK WASHER	4	
31	0041210000	PLAIN WASHER	4	
32	C1138000003	FIELD ASS'Y EXCITER	1	
33	C0130100003	STATOR ASSEMBLY	1	INCLUDE ITEMS W/#
34#	0845041804	GROMMET	2	
35#	0601850144	GROMMET	1	
36#	0012112035	HEX. HEAD BOLT	12	
37	0042512000	LOCK WASHER	27	
38	C0132300003	COVER, FAN	1	
39	0010106030	HEX. HEAD BOLT	1	
40	0040020000	LOCK WASHER	4	
41	0030020000	HEX. NUT	4	
42*	0042512000	LOCK WASHER	1	

DCA-180SSK — CONTROL PANEL ASSY.

CONTROL PANEL ASSY.

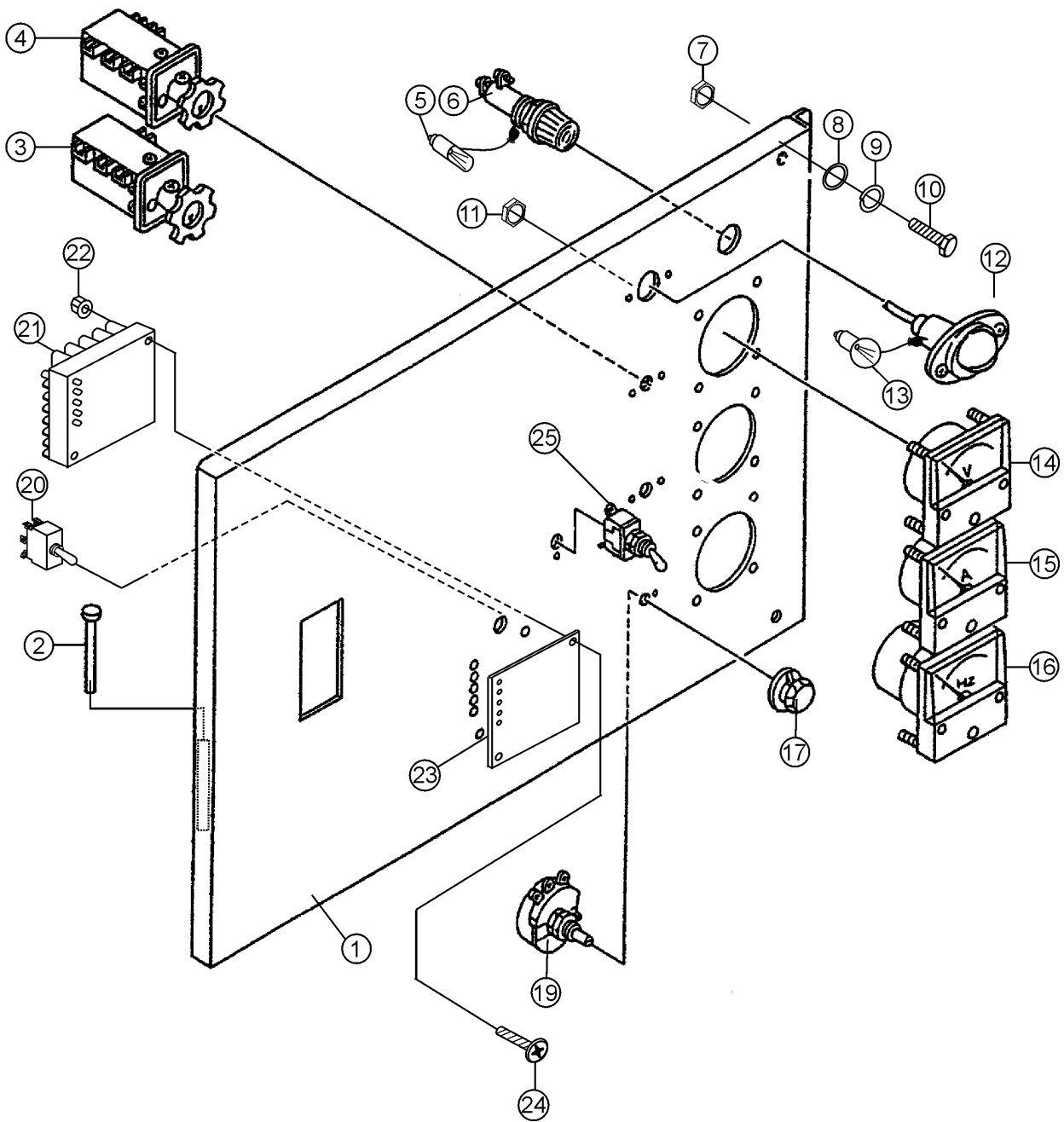

DCA-180SSK — CONTROL PANEL ASSY.

CONTROL PANEL ASSY.

<u>NO</u>	<u>PART NO</u>	<u>PART NAME</u>	<u>QTY.</u>	<u>REMARKS</u>
1	C0224001203	CONTROL PANEL	1	
2	0605011211	PIN	2	
3	0601801040	CHANGE-OVER SW., AMMETER	1	SL-2 AS
4	0601801041	CHANGE-OVER SW., VOLTMETER	1	SL-2 VS
5*	0601810261	BULB	1	CT-13W
6	0601810072	PILOT LAMP	1	LP-132DC 220V INCLUDES ITEM W/*
7	0080200007	SNAP RING	2	
8	0041208000	PLAIN WASHER	2	
9	0040008000	LOCKWASHER	2	
10	C9221100004	HEX. HEAD BOLT	2	
11	0207004000	HEX. NUT	2	
12	0601810161	PANEL LIGHT	1	CV325070 INCLUDES ITEM W/#
13#	0601810214	BULB	1	
14	0601806887	AC VOLTMETER	1	RSR-80 0~600V
15	0601806967	AC AMMETER	1	RSS-80 0~300A,0~600A
16	0601807622	FREQUENCY METER	1	RSC-80F 220V 45~65Hz
17	0601840121	KNOB	1	
18	0601830710	SWITCH, PANEL LIGHT	1	S-301T
19	0601840073	RHEOSTAT (VOLTAGE REGULATOR)	1	RA20A2SE102BJ
20	0601830765	SWITCH	1	S-303T
21	ECU9988N	MPEC (MICRO. PROCSSOR ENG. CTRL.) ..	1	REPLACES 0602202545
22	M0000001329Q	NUT B7-8	2	
23	M0000020001Q	MPEC LABEL	1	
24	M1001021017Q	MACHINE SCREW 7-8	2	
25	0601830710	SWITCH, PANEL LIGHT	1	S-301T

DCA-180SSK — CONTROL BOX ASSY.

CONTROL BOX ASSY.

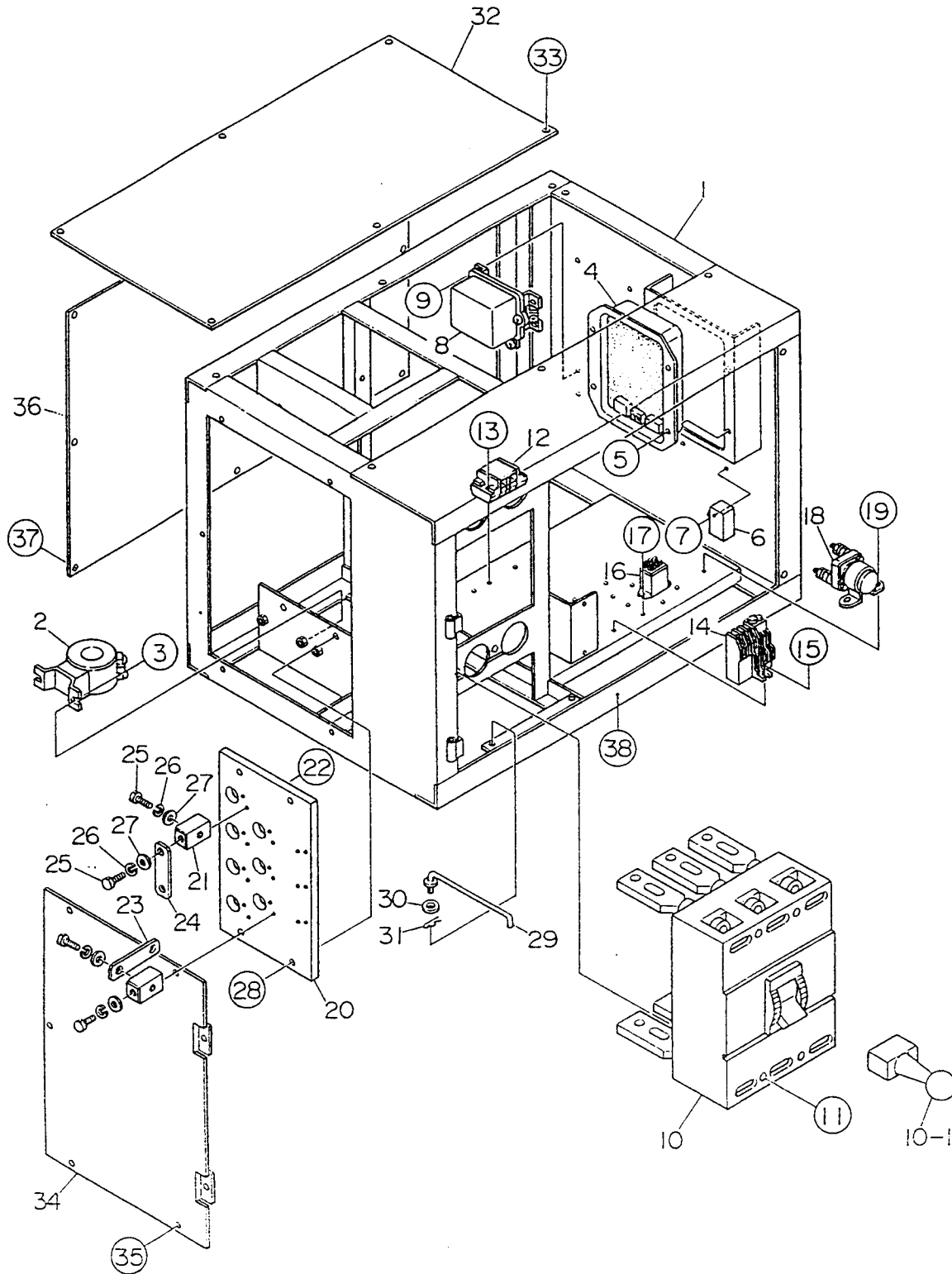

DCA-180SSK — CONTROL BOX ASSY.

CONTROL BOX ASSY.

<u>NO.</u>	<u>PART NO.</u>	<u>PART NAME</u>	<u>QTY.</u>	<u>REMARKS</u>
1	C0214000502	CONTROL BOX	1	
2	0601806132	CURRENT TRANSFORMER	3	CT5MRN 300/5A
3	0017106016	HEX. HEAD BOLT	6	
	0207006000	HEX. NUT	2	
4	0601820625	AUTOMATIC VOLT. REGULATOR	1	NTA5A2T
5	0027105012	MACHINE SCREW	4	
6	0602201911	UNIT, BATTERY SENSOR	1	C7038A0000
7	0017106020	HEX. HEAD BOLT	1	
8	0602200446	EMERGENCY RELAY	1	6008151252
9	0017106016	HEX. HEAD BOLT	4	
10	0601808262	CIRCUIT BREAKER	1	XE600NS 500A
10-1	0601802525	HANDLE, CIRCUIT BREAKER	1	XHA9
11	0021008045	MACHINE SCREW	4	
	0207008000	HEX. NUT	4	
	0040008000	LOCK WASHER	4	
	0042108000	PLAIN WASHER	4	
12	0601815730	TERMINAL BOARD	1	KT302P
13	0027104020	MACHINE SCREW	2	
14	0601820892	OVER CURRENT RELAY	1	THN20HZ
15	0027104016	MACHINE SCREW	2	
16	0601824542	RELAY	1	HH62SDC24A
17	0027103010	MACHINE SCREW	2	
18	0602201227	HEATER RELAY	1	6008152970
19	0027106016	MACHINE SCREW	2	
20	C0274000003	CHANGE OVER BOARD, VOLT.	1	
21	8131852104	CHANGE TERMINAL	10	
22	0017106025	HEX. HEAD BOLT	20	
23	C0277200004	TERMINAL PLATE	3	
24	8131853104	CHANGE PLATE	6	
25	8131852504	HEX. HEAD BOLT	20	
26	0040010000	LOCK WASHER	20	
27	0041410000	PLAIN WASHER	20	
28	0017108035	HEX. HEAD BOLT	4	
	0207008000	HEX. NUT	4	
29	3871824004	STOPPER, CONTROL PANEL	1	
30	0041206000	PLAIN WASHER	1	
31	0605010502	SNAP PIN	1	SSP6
32	C0214500004	COVER, CONTROL BOX	1	
33	0017108020	HEX. HEAD BOLT	6	
34	C0214300004	SIDE PANEL, CONTROL BOX	1	
35	0017108020	HEX. HEAD BOLT	5	
36	C0214400004	PANEL, CONTROL BOX	1	
37	0017108020	HEX. HEAD BOLT	8	
38	0017108020	HEX. HEAD BOLT	4	

DCA-180SSK — ENGINE RADIATOR ASSY.

ENGINE & RADIATOR ASSY.

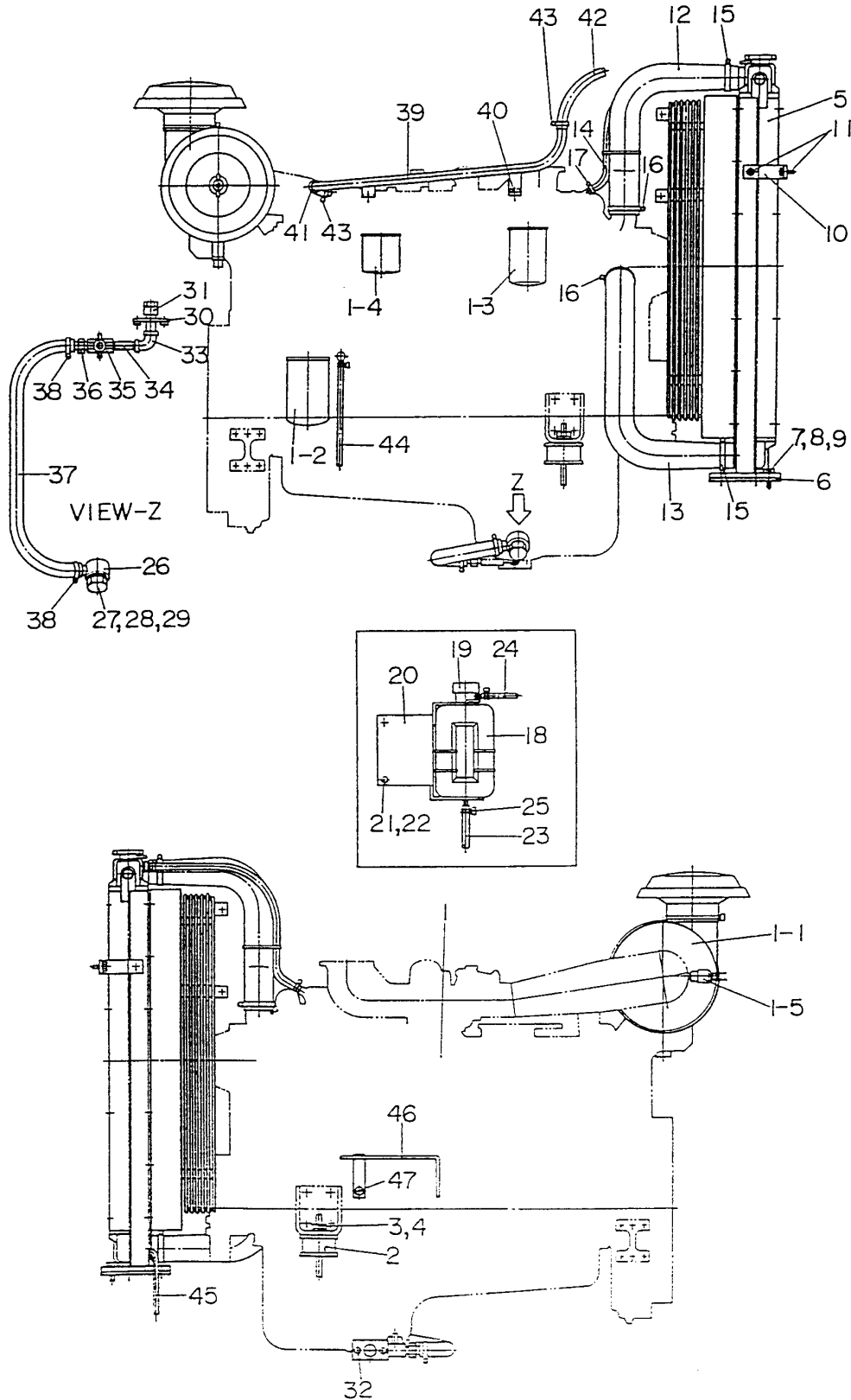

DCA-180SSK — ENGINE RADIATOR ASSY.

ENGINE & RADIATOR ASSY.

<u>NO.</u>	<u>PART NO.</u>	<u>PART NAME</u>	<u>QTY.</u>	<u>REMARKS</u>
1	C0925200054	ENGINE	1	KOMATSU SA6D108E-2
1-1	6001823200	ELEMENT, AIR CLEANER	1	REPLACES 0602046333
1-2	6136515121	CARTRIDGE, OIL FILTER	1	REPLACES 0602041147
1-3	6003118293	CARTRIDGE, FUEL FILTER	1	REPLACES 0602042146
1-4	6004111151	CARTRIDGE, CORROSION RESISTOR	1	REPLACES 0602045143
1-5	0602040678	DUST SENSOR	1	
2	0605000011	RUBBER SUSPENSION	2	
3	0030016000	HEX. NUT	4	
4	0040016000	LOCK WASHER	4	
5	6222619210	RADIATOR	1	REPLACES 0602011984;INCLUDE ITEM W/*
5-1*		RADIATOR CAP	1	
6	6152619170	RUBBER SHEET	2	REPLACES 0605000490
7	0010112060	HEX. HEAD BOLT	4	
8	0030012000	HEX. NUT	8	
9	0041212000	PLAIN WASHER	8	
10	C0311100104	BRACKET, RADIATOR	2	
11	0017110025	HEX. HEAD BOLT	4	
12	6221619350	RADIATOR HOSE	1	REPLACES 0602014594
13	6221619360	RADIATOR HOSE	1	REPLACES 0602014645
14	0726020980	RADIATOR HOSE	1	REPLACES 0602013977
15	0728100709	HOSE BAND	2	REPLACES 0602014068
16	0728100809	HOSE BAND	2	REPLACES 0602014067
17	0728100197	HOSE BAND	2	REPLACES 0602014058
18	C0802081003	RESERVE TANK	1	REPLACES 0802081003
19	0802010900	CAP, RESERVE TANK	1	REPLACES 0602010900
20	C0317100203	BRACKET, RESERVE TANK	1	
21	0021108020	MACHINE SCREW	2	
22	0207008000	HEX. NUT	2	
23	0199901400	HOSE	1	
24	0193601200	HOSE	1	
25	0605515013	HOSE BAND	2	
26	C9101000104	DRAIN JOINT	1	
27	0802024004	PACKING, OIL PAN SIDE	1	
28	0805008004	PACKING	1	
29	0802025104	JOINT BOLT	1	
30	C0321200004	DRAIN JOINT	1	
31	C0321300004	CAP	1	
32	00171108025	HEX. HEAD BOLT	2	
33	0130008000	ELBOW JOINT, 3/4	1	
34	0134308100	LONG NIPPLE	1	
35	0603325017	VALVE	1	BBS-220-20
36	0602022294	HOSE JOINT	1	
37	0265800850	DRAIN HOSE	1	
38	0605515003	HOSE BAND	2	
39	C0327100003	BREATHER PIPE	1	
40	0017110020	HEX. HEAD BOLT	2	
41	0265800180	HOSE	1	
42	0265800800	HOSE	1	
43	0605515003	HOSE BAND	4	
44	0269100800	HOSE	1	
45	0193600450	HOSE	1	
46	C0358300004	CLAMPER ROD	1	
47	0017110020	HEX. HEAD BOLT	1	

DCA-180SSK — ENGINE OPERATING PANEL ASSY.

ENGINE OPERATING PANEL ASSY.

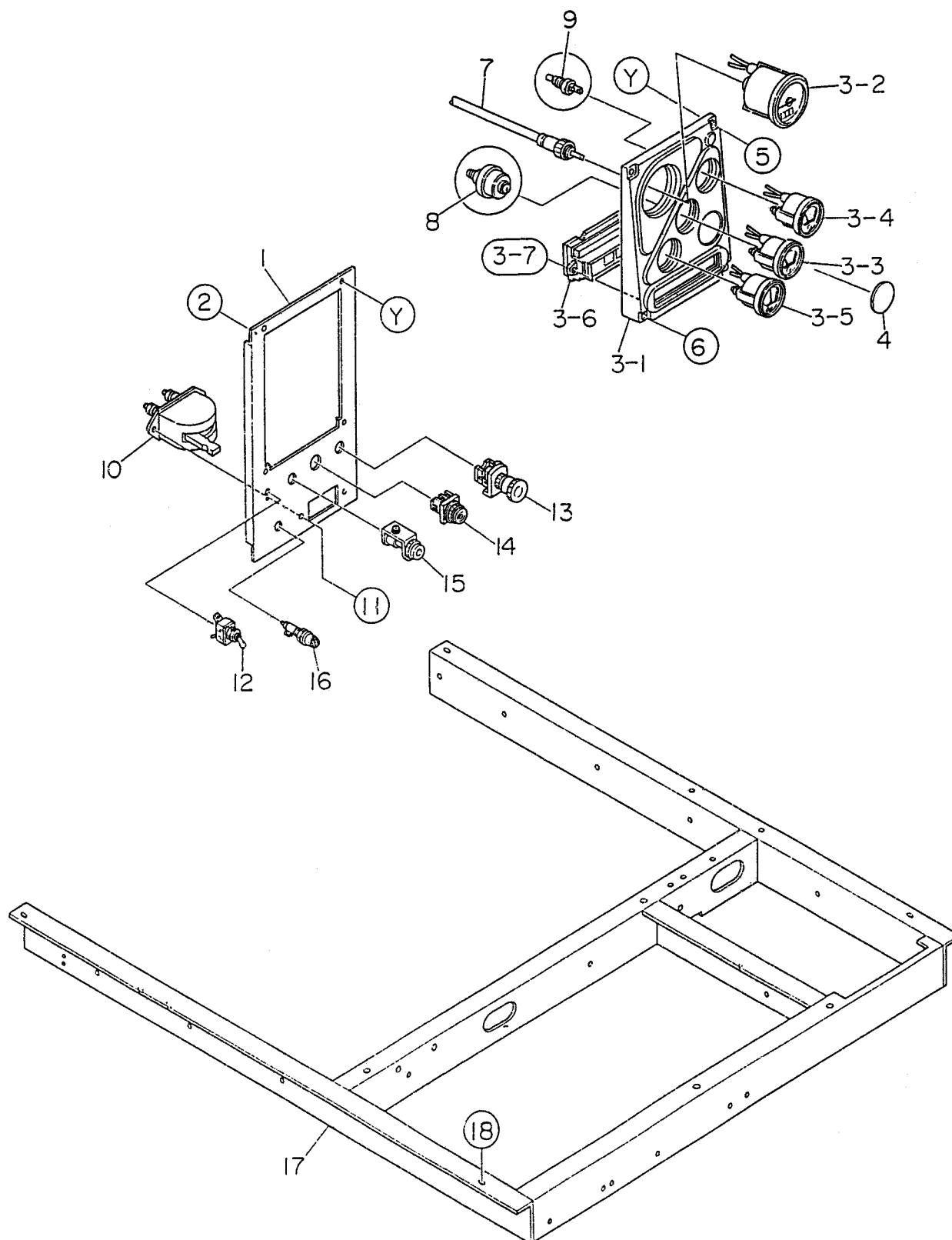

DCA-180SSK — ENGINE OPERATING PANEL ASSY.

ENGINE OPERATING PANEL ASSY.

<u>NO</u>	<u>PART NO</u>	<u>PART NAME</u>	<u>QTY.</u>	<u>REMARKS</u>
1	C0353100003	OPERATING PANEL	1	
2	0207006000	HEX.. NUT	5	
3	0602120562	METER PANEL ASSY.	1	257310-9890 INCLUDES ITEM W/*
	0602120701	WIRING HARNESS	1	
3-1*	0602129033	METER PANEL	1	0577764490
3-2*	0602120069	TACHOMETER	1	1005694600
3-3*	0602122037	OIL PRESSURE GAUGE	1	1005694600
3-4*	0602123087	WATER TEMPERATURE GAUGE	1	1005760430
3-5*	0602121060	CHARGING AMMETER	1	1005730330
3-6*	0602115037	ENGINE WARNING DISPLAY LED	1	0559004040
3-7*	0602129031	MACHINE SCREW	2	
4	B9501401504	COVER	1	
5	0021806020	MACHINE SCREW	2	
6	0021806050	MACHINE SCREW	2	
7	0602120129	CABLE, TACHOMETER	1	0578909990
8	0602122251	UNIT, OIL PRESSURE	1	0716000760
9	0602123250	UNIT, WATER TEMPERATURE ...	1	0715000331
10	0602101000	BATTERY SWITCH	1	9827300090
11	0021008080	MACHINE SCREW	2	
	0030008000	HEX.. NUT	2	
	0040008000	LOCK WASHER	2	
	0041208000	PLAIN WASHER	4	
12	0601830710	ENGINE SPEED SWITCH	1	S-301T
13	0601831557	EMERGENCY STOP BUTTON ...	1	AR22V2R-01R
14	0601830448	PREHEAT BUTTON	1	AH25FB10
15	6008152371	PREHEAT LAMP	1	REPLACES 0602103091
16	0602103090	DETECTED LAMP, FUEL LEAK	1	
	0601810244	BULB	1	
17	C0484000003	SET FRAME	1	
18	0017110030	HEX.. HEAD BOLT	4	
	0207010000	HEX.. NUT	4	

DCA-180SSK — OUTPUT TERMINAL ASSY.

OUTPUT TERMINAL ASSY.

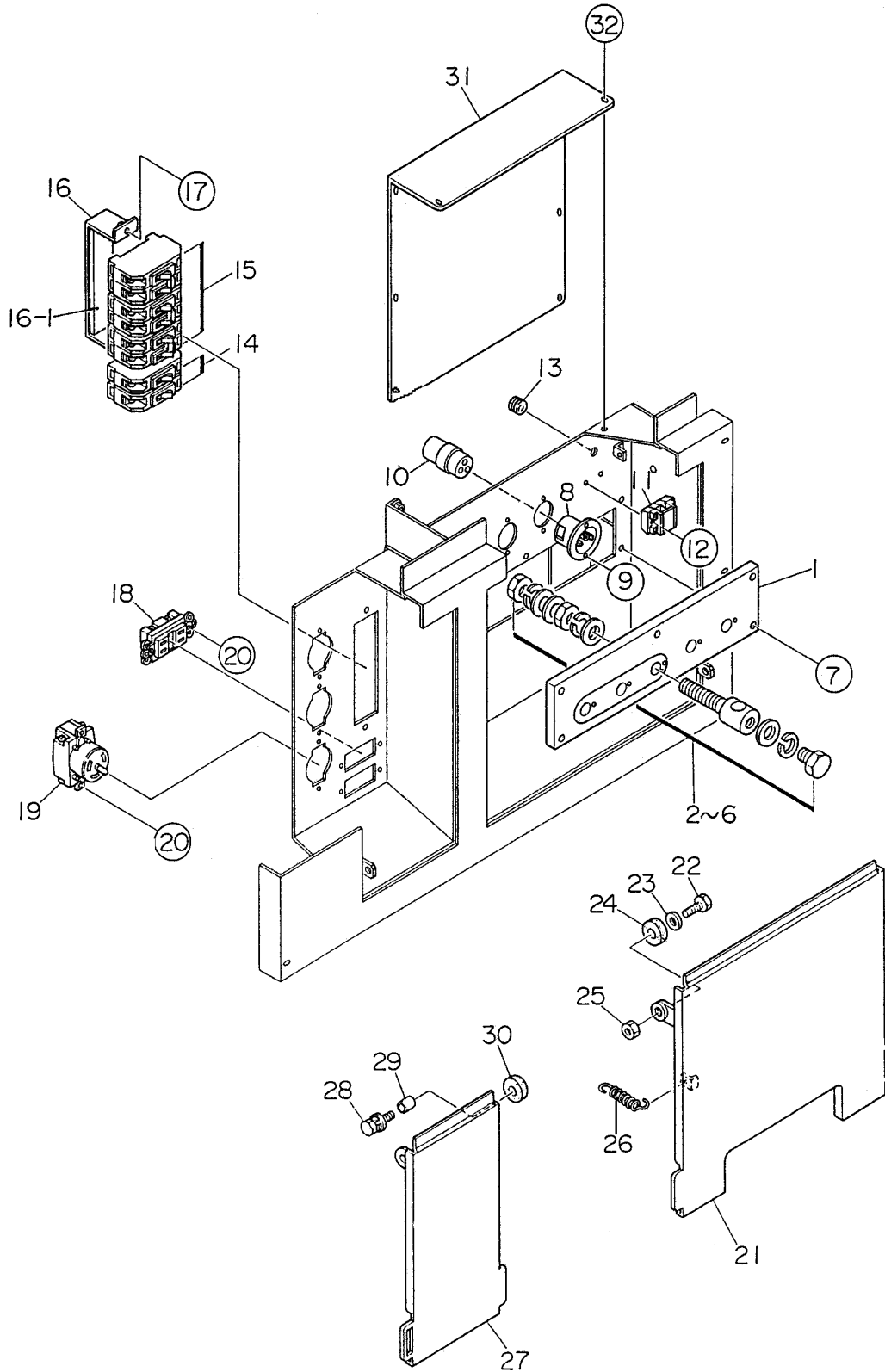

DCA-180SSK — OUTPUT TERMINAL ASSY.

OUTPUT TERMINAL ASSY.

<u>NO.</u>	<u>PART NO.</u>	<u>PART NAME</u>	<u>QTY.</u>	<u>REMARKS</u>
1	C0231700003	SET BOARD, OUTPUT TERMINAL	1	
2	0801830404	OUTPUT TERMINAL	5	
3	0801830904	HEX.. HEAD BOLT	5	
4	0039320000	HEX.. NUT	10	
5	0040020000	LOCK WASHER	15	
6	0041420000	PLAIN WASHER	20	
7	0017108040	HEX.. HEAD BOLT	5	
8	0601811189	RECEPTACLE	2	HBL5378C 125V 20A
9	0027103010	MACHINE SCREW	4	
10	0601812537	ADAPTER	1	HBL5369C 125V 20A
11	0601815324	TERMINAL BOARD	1	TS-2 2P
12	0027104020	MACHINE SCREW	2	
13	0601850275	GROMMET	1	SG-14A
14	0601804887	CIRCUIT BREAKER	2	KM-51B 265V 20A REPLACES 0601805313
15	0601805840	CIRCUIT BREAKER	3	KM-52 265V 50A
16	C1261600204	BRACKET, CIRCUIT BREAKER	1	
16-1	0223300200	RUBBER CUSHION	1	
17	0017106020	HEX.. HEAD BOLT	2	
18	0601812597	RECEPTACLE	2	REPLACES 0601812598
19	0601811034	RECEPTACLE	3	REPLACES 0601812565
20	0027104016	MACHINE SCREW	10	
	0030004000	HEX.. NUT	10	
	0041204000	PLAIN WASHER	10	
21	C0237101313	COVER, OUTPUT TERMINAL	1	
22	0019112045	HEX.. HEAD BOLT	2	
23	0042412000	PLAIN WASHER	2	
24	0805015604	STAY WASHER	2	
25	0205012000	HEX.. NUT	2	
26	0845043704	SPRING	2	
27	C0237101504	COVER	1	
28	0017110040	HEX.. HEAD BOLT	2	
29	0845054204	COLLAR	2	
30	0805015604	STAY RUBBER	1	
31	C0237101414	COVER	1	
32	0017108020	HEX.. HEAD BOLT	7	

DCA-180SSK — BATTERY ASSY.

BATTERY TERMINAL ASSY.

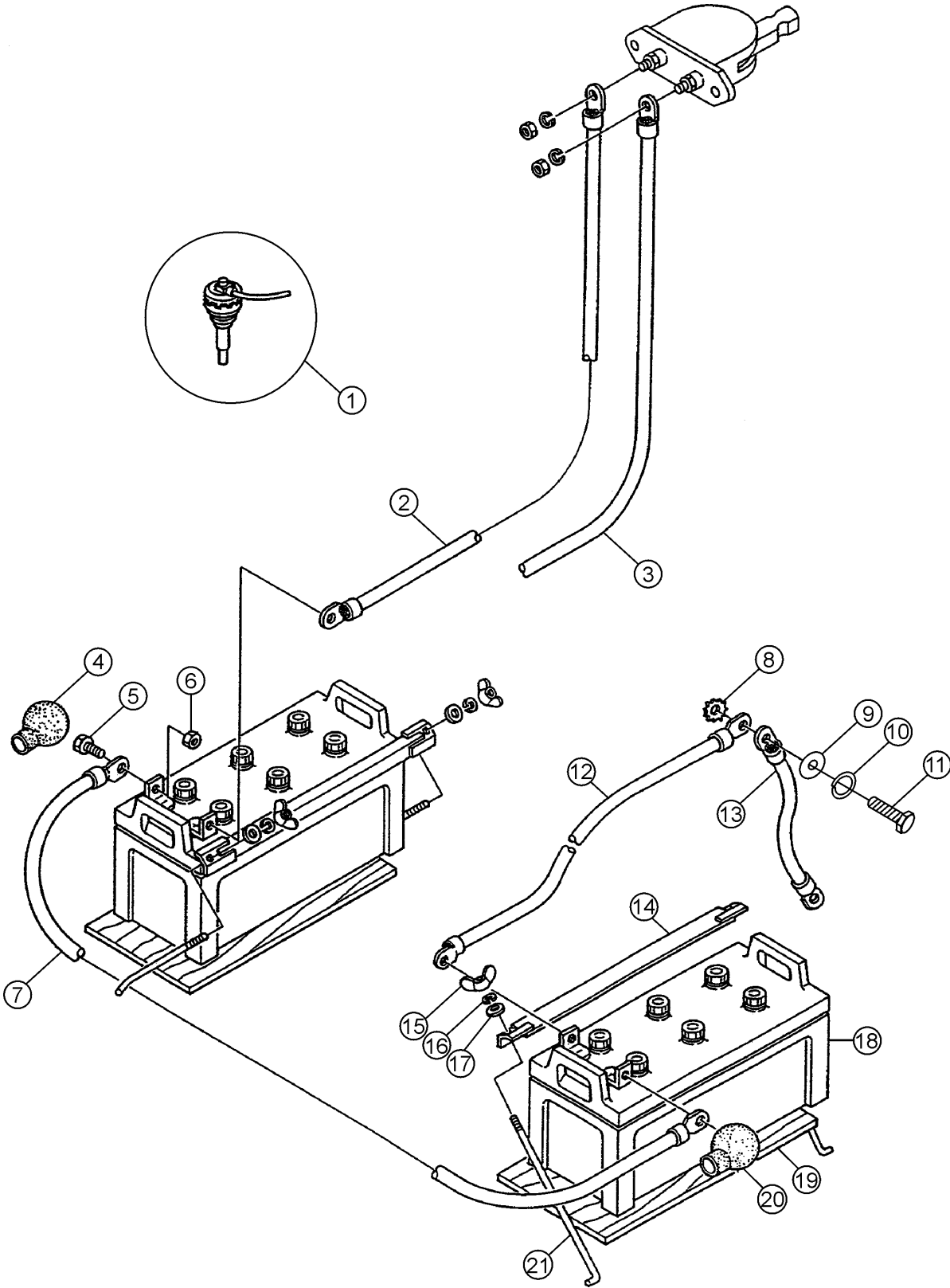

BATTERY TERMINAL ASSY.

<u>NO.</u>	<u>PART NO.</u>	<u>PART NAME</u>	<u>QTY.</u>	<u>REMARKS</u>
1	0602220203	BATTERY SENSOR	1 AISP
2	8302265104	BATTERY CABLE	1	
3	8302265704	BATTERY CABLE	1	
4	0845041304	TERMINAL CAP (-)	2	
5	0010010030	HEX. HEAD BOLT	4	
6	0030010000	HEX. NUT	4	
7	8302265304	BATTERY CABLE	1	
8	0040512000	TOOTHED WASHER	1	
9	0041212000	PLAIN WASHER	1	
10	0040012000	LOCK WASHER	1	
11	00100-12025	HEX. HEAD BOLT	1	
12	83022-65504	BATTERY CABLE	1	
13	C0347200104	EARTH CABLE	1	
14	0805000904	BATTERY BAND	2	
15	0037808000	WING NUT	4	
16	0040008000	LOCK WASHER	4	
17	0041208000	PLAIN WASHER	4	
18	065511551	BATTERY	2 REPLACES 0168511551
19	0805000804	BATTERY SHEET	2	
20	0845040414	TERMINAL CAP (+)	2	
21	0805002904	BATTERY BOLT	4	

DCA-180SSK — MUFFLER ASSY.

MUFFLER ASSY.

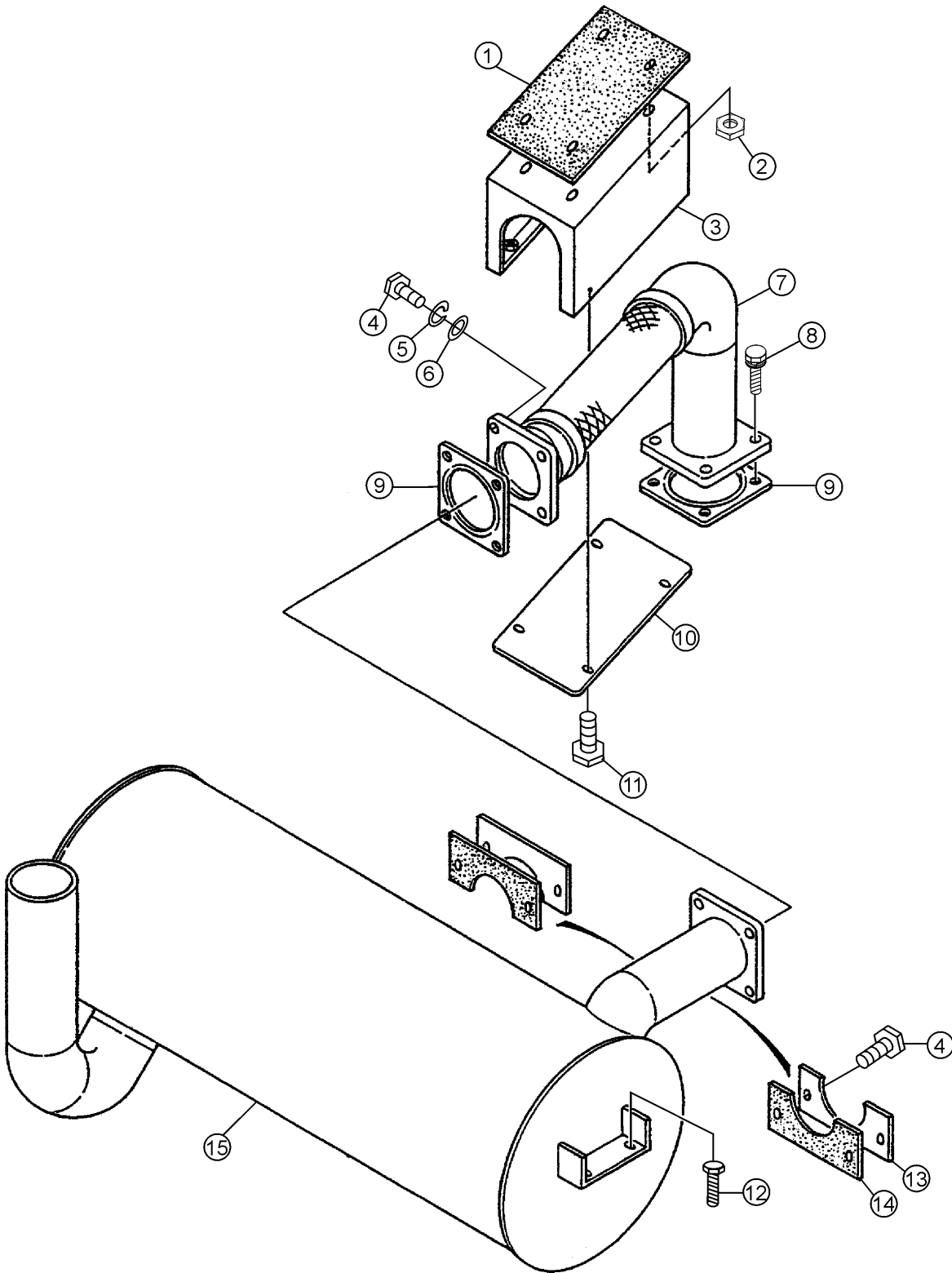

MUFFLER ASSY.

<u>NO.</u>	<u>PART NO.</u>	<u>PART NAME</u>	<u>QTY.</u>	<u>REMARKS</u>
1	C0334200204	SHEET	1	
2	0207308000	HEX. NUT	4	
3	C0331400104	COVER, EXHAUST PIPE	1	
4	0010112050	HEX. HEAD BOLT	4	
5	0030012000	HEX. NUT	8	
6	0041212000	PLAIN WASHER	16	
7	C0334000003	EXHAUST PIPE	1	
8	0012112045	HEX. HEAD BOLT	4	
9	6150115751	GASKET	2	REPLACES 0602320142
10	C0331400003	COVER, EXHAUST PIPE	1	
11	0017108020	HEX. HEAD BOLT	8	
12	0017110025	HEX. HEAD BOLT	4	
13	8252354004	COVER	2	
14	C0334200104	SHEET	2	
15	C0331100302	MUFFLER	1	

DCA-180SSK — ENCLOSURE ASSY.

ENCLOSURE ASSY.

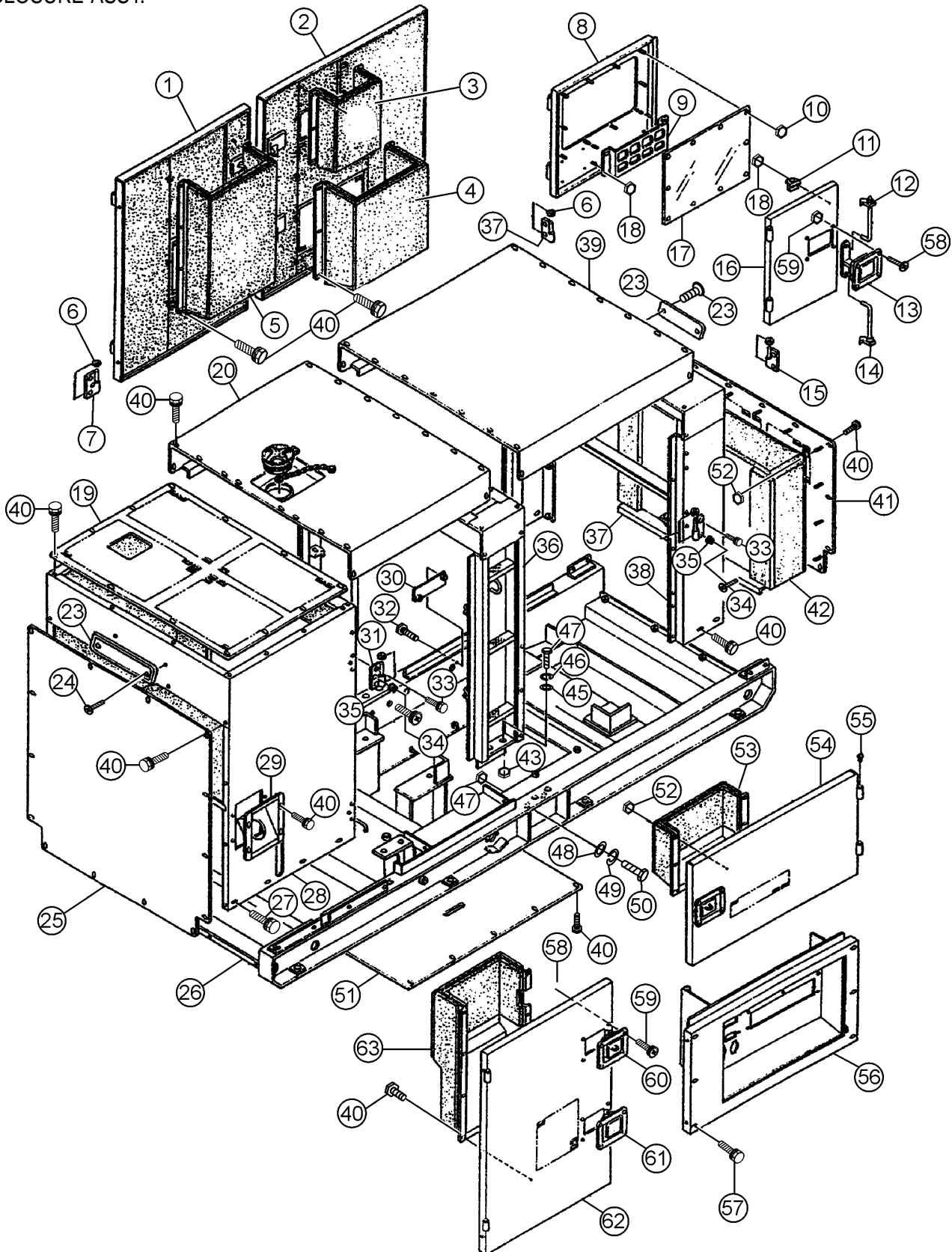

DCA-180SSK — ENCLOSURE ASSY.

ENCLOSURE ASSY.

<u>NO.</u>	<u>PART NO.</u>	<u>PART NAME</u>	<u>QTY.</u>	<u>REMARKS</u>
1	C0454001103	SIDE DOOR	1	
2	C0454003003	SIDE DOOR	1	
3	C0454301004	DUCT	1	
4	C0454301804	DUCT	1	
5	C0454301404	DUCT	1	
6	0845045004	WASHER	12	
7	0845047004	HINGE	2	
8	C0444200413	DOOR, REAR FRAME	1	
9	B9114500104	DOOR POCKET	1	
10	0207306000	HEX. NUT	10	
11	0845050704	STAY	4	
12	8255146104	DOOR ROD	1	
13	B9114000102	DOOR HANDLE	1	
14	8255146204	DOOR ROD	1	
15	M9110100204	HINGE	2	REPLACES 0845047104
16	8155143703	DOOR, REAR FRAME	1	
17	8165157004	WINDOW PLATE	1	
18	0207006000	HEX. NUT	12	
19	C0424200104	COVER, FRONT FRAME	1	
20	C0464100503	ROOF PANEL	1	
21	0845052203	FILLER COVER	1	
22	1625165204	CHAIN	1	
23	0600500090	EMBLEM	2	
24	0021106020	MACHINE SCREW	4	
25	C0424200003	COVER, FRONT FRAME	1	
26	C0414001502	BASE	1	
27	0017110020	HEX. HEAD BOLT	4	
28	C0424001120	FRONT FRAME	1	

ADD THE FOLLOWING DIGITS AFTER THE PART NUMBER
WHEN ORDERING ANY PAINTED PANEL TO INDICATE

COLOR OF UNIT:

1-ORANGE	5 -BLACK
2-WHITE	6 -CATERPILLAR YELLOW
3 -SPECTRUM GRAY	7 -CATO GOLD
4 -SUNBELT GREEN	8 -RED

THE SERIAL NUMBER MAY BE REQUIRED.

DCA-180SSK — ENCLOSURE ASSY.

ENCLOSURE ASSY.

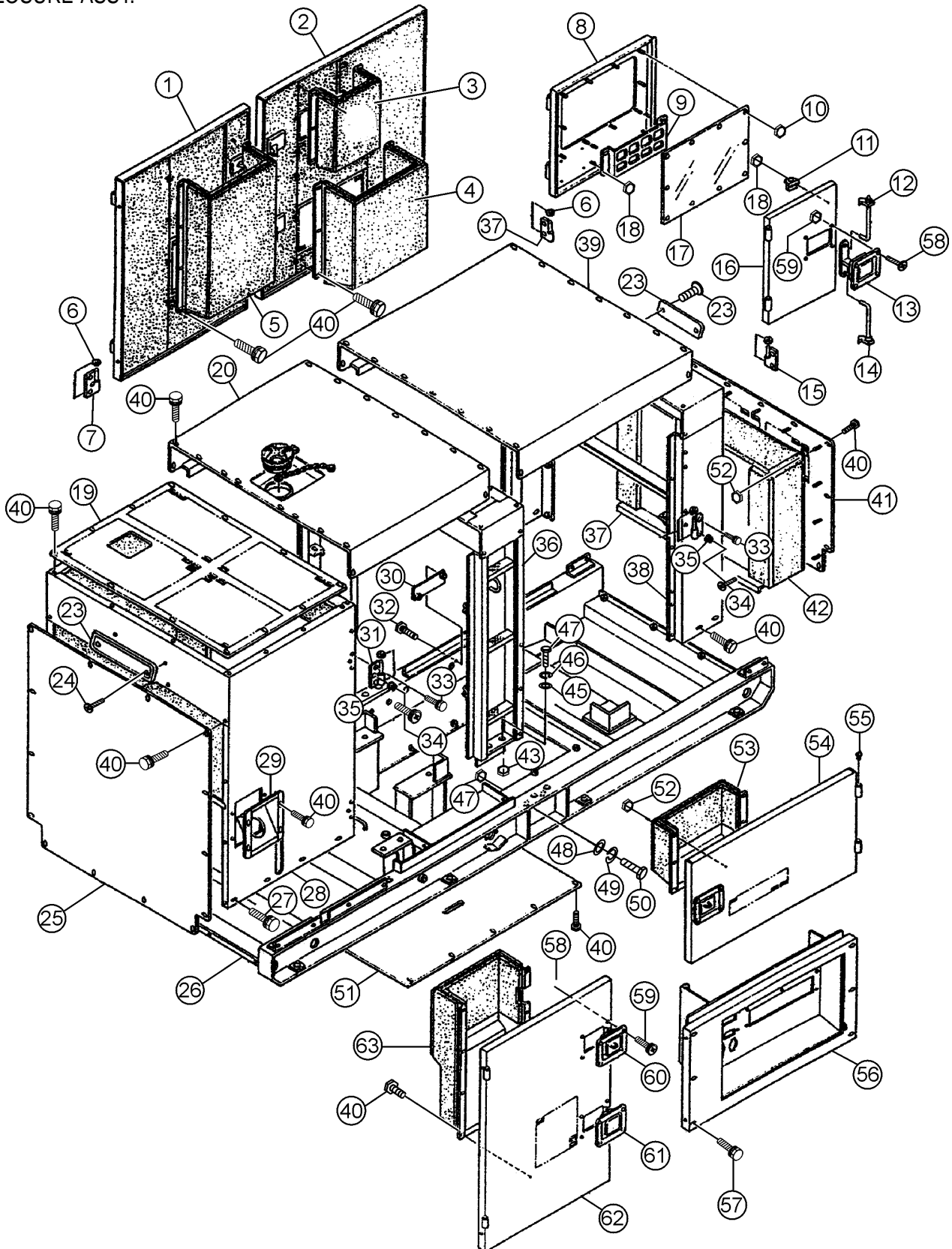

DCA-180SSK — ENCLOSURE ASSY.

ENCLOSURE ASSY.

<u>NO.</u>	<u>PART NO.</u>	<u>PART NAME</u>	<u>QTY.</u>	<u>REMARKS</u>
29	0845039703	FILLER BRACKET	1	
30	C0414400104	COVER	1	
31	0845046904	HINGE	4	
32	0017108025	HEX. HEAD BOLT	2	
33	0019208020	HEX. HEAD BOLT	20	
34	0021008025	MACHINE SCREW	10	
35	0601850097	STOPPER	10	
36	C0434000302	CENTER FRAME	1	
37	M9110100304	HINGE	4	REPLACES 08450-47204
38	C0444000302	REAR FRAME	1	
39	C0464200003	ROOF PANEL	1	
40	0017108020	HEX. HEAD BOLT	83	
41	C0444300704	COVER, REAR FRAME	1	
42	C0454300803	DUCT	1	
43	0030014000	HEX. NUT	4	
44	0040014000	LOCK WASHER	4	
45	0041214000	PLAIN WASHER	8	
46	0010114050	HEX. HEAD BOLT	4	
47	0030020000	HEX. NUT	4	
48	0040020000	LOCK WASHER	4	
49	0041220000	PLAIN WASHER	8	
50	0010120045	HEX. HEAD BOLT	4	
51	7765116004	FLOOR PANEL	1	
52	0207008000	HEX. NUT	51	
53	C0454301704	DUCT	1	
54	C0454002903	SIDE DOOR	1	
55	0845031504	CAP	12	
56	C0454201602	SPLASHER PANEL	1	
57	0017108070	HEX. HEAD BOLT	6	
58	0021806016	MACHINE SCREW	32	
59	0030006000	HEX. NUT	32	
60	B9114000002	DOOR HANDLE	4	
61	0825007362	DOOR HANDLE	3	
62	C0454002003	SIDE DOOR	1	
63	C0454300904	DUCT	1	

ADD THE FOLLOWING DIGITS AFTER THE PART NUMBER
WHEN ORDERING ANY PAINTED PANEL TO INDICATE
COLOR OF UNIT:

1-ORANGE	5-BLACK
2-WHITE	6-CATERPILLAR YELLOW
3-SPECTRUM GRAY	7-CATO GOLD
4-SUNBELT GREEN	8-RED

THE SERIAL NUMBER MAY BE REQUIRED.

DCA-180SSK — ENCLOSURE LINING ASSY.

ENCLOSURE LINING ASSY.

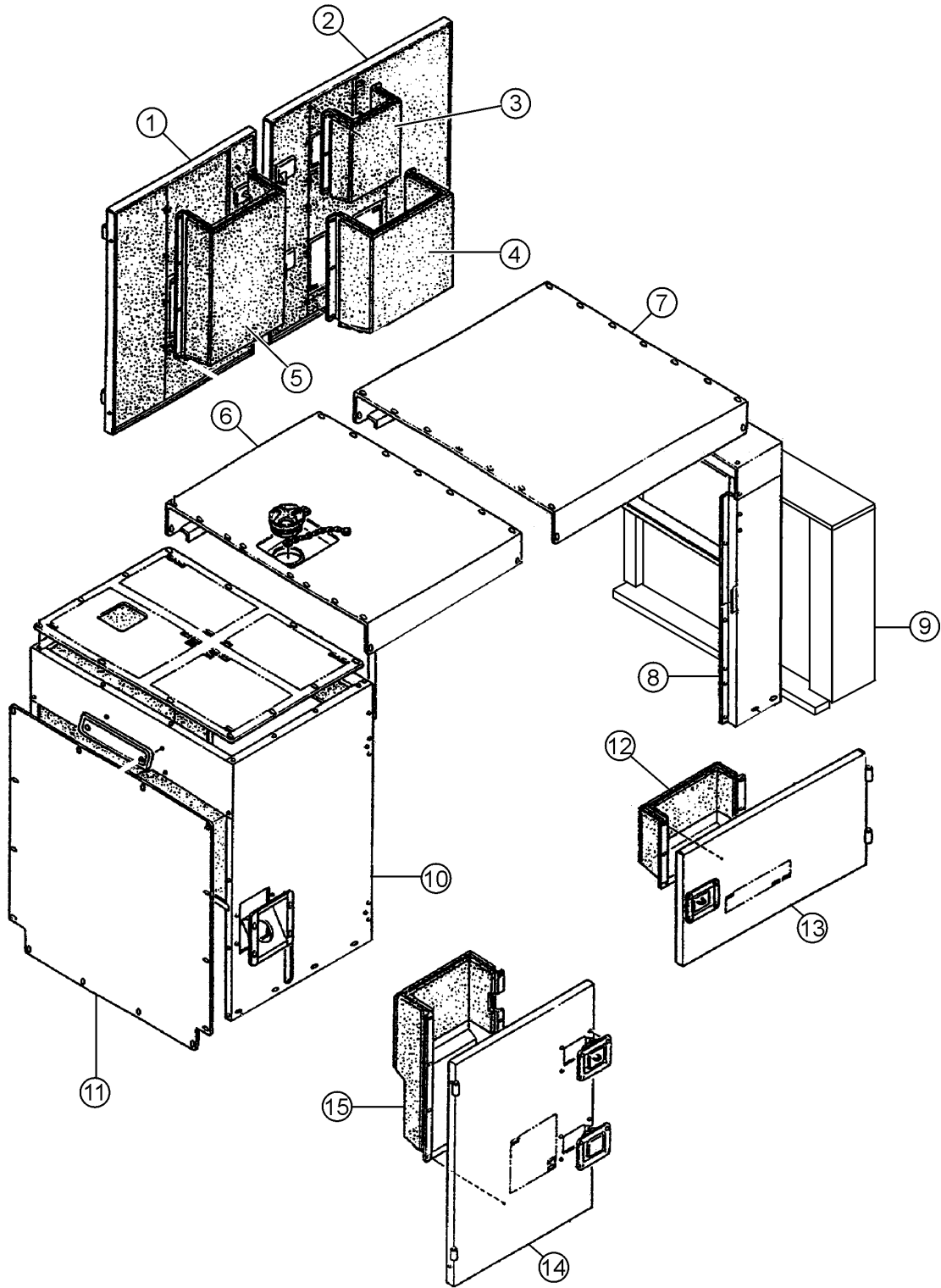

DCA-180SSK — ENCLOSURE LINING ASSY.

ENCLOSURE LINING ASSY.

<u>NO.</u>	<u>PART NO.</u>	<u>PART NAME</u>	<u>QTY.</u>	<u>REMARKS</u>
1	C0494404104	LINING	1	FOR ITEM C0454001103
2	C0494404304	LINING	1	FOR ITEM C0454003003
3	C0494600804	LINING	1	FOR ITEM C0454301004
4	C0494601104	LINING	1	FOR ITEM C0454301804
5	C0494600304	LINING	1	FOR ITEM C0454301404
19	C0495100003	LINING	1	FOR ITEM C0424201004
20	C0494501604	LINING	1	FOR ITEM C0464100503
25	C0494500504	LINING	1	FOR ITEM C0464200003
38	C0494300504	LINING	2	FOR ITEM C0444000302
42	C0494600403	LINING	1	FOR ITEM C0454300803
53	C0494601004	LINING	1	FOR ITEM C0454301704
54	C0494404204	LINING	1	FOR ITEM C0454002903
63	C0494600704	LINING	1	FOR ITEM C0454300904

DCA-180SSK — ENCLOSURE ASSY. (RUBBER SEALS)

RUBBER SEALS ASSY.

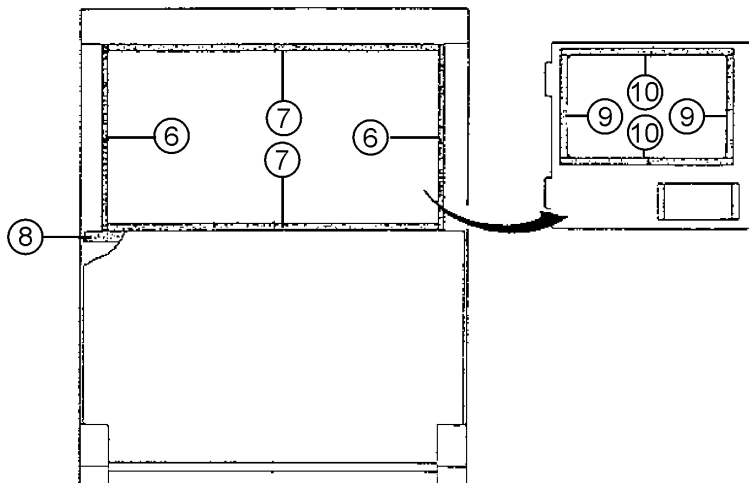
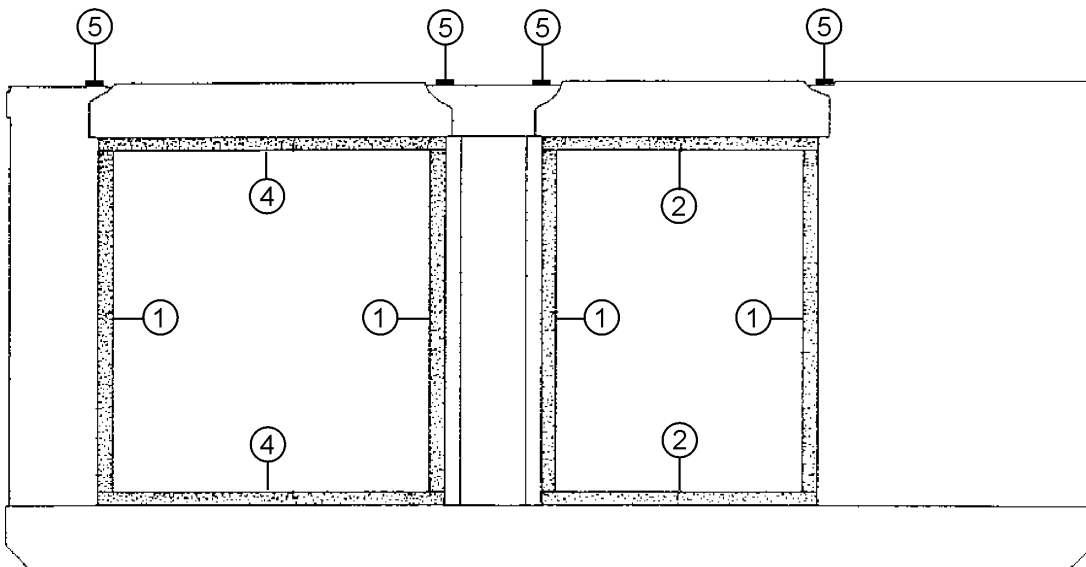
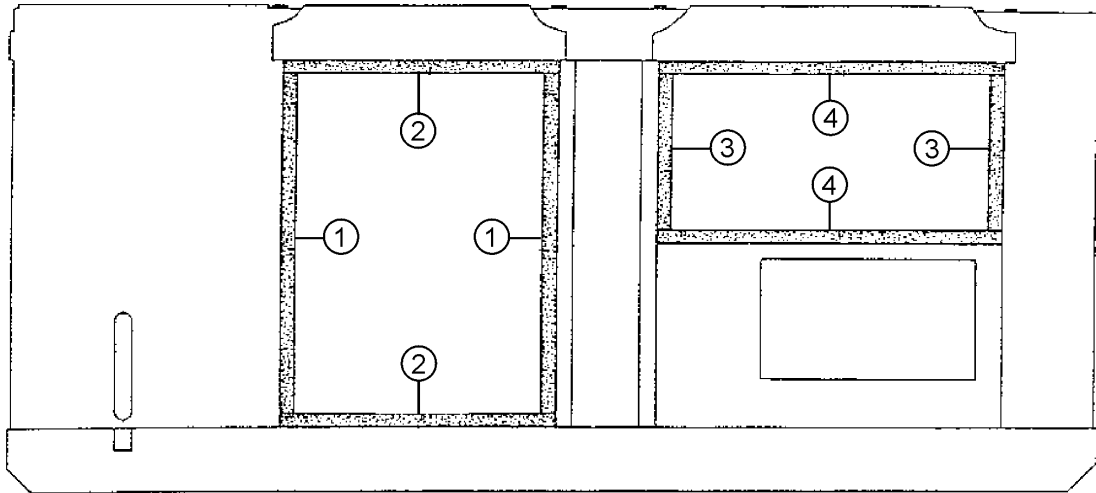

DCA-180SSK — ENCLOSURE ASSY. (RUBBER SEALS)

RUBBER SEALS ASSY.

<u>NO.</u>	<u>PART NO.</u>	<u>PART NAME</u>	<u>QTY.</u>	<u>REMARKS</u>
1	0228901080	RUBBER SEAL	6	
2	0228900840	RUBBER SEAL	4	
3	0228900520	RUBBER SEAL	2	
4	0228901070	RUBBER SEAL	4	
5	0229201200	RUBBER SEAL	4	
6	0228800600	RUBBER SEAL	2	
7	0228801040	RUBBER SEAL	2	
8	0229201100	RUBBER SEAL	1	
9	0228100320	RUBBER SEAL	1	
10	0228100540	RUBBER SEAL	2	

DCA-180SSK — NAME PLATE AND DECALS

NAME PLATE AND DECALS

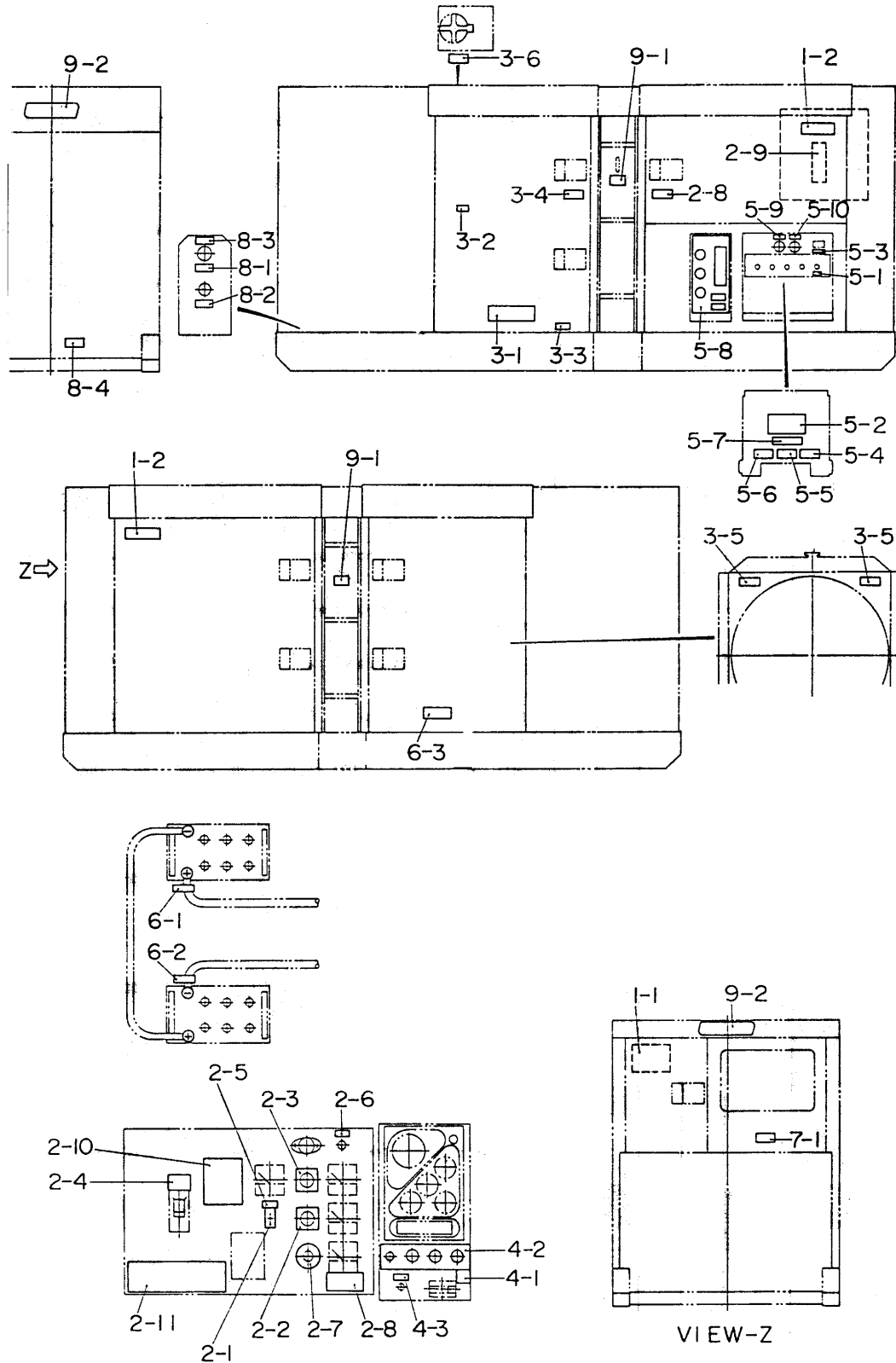

DCA-180SSK — NAME PLATE AND DECALS

NAMEPLATE ASSY.

<u>NO</u>	<u>PART NO</u>	<u>PART NAME</u>	<u>QTY.</u>	<u>REMARKS</u>
1-1	C1552000403	DECAL; HANDLING PROCEDURES	1	C15200040
1-2	B1552000103	DECAL; CAUTION	2	B15200010
CONTROL BOX GROUP				
2-1	0800520100	DECAL; ON-OFF	1	AT-202
2-2	0800520904	PLATE; AMMETER CHANGE-OVER SWITCH	1	N-2438
2-3	0800520814	PLATE; VOLTMETER CHANGE-OVER SWITCH	1	N-24391
2-4	0840624504	DECAL; CIRCUIT BREAKER	1	S-3031
2-5	0840624604	DECAL; PANEL LIGHT SWITCH	1	S-3032
2-6	0840624704	DECAL; PILOT LAMP	1	S-3033
2-7	0840624804	DECAL; VOLTAGE REGULATOR	1	S-3034
2-8	B9531100604	DECAL; WARNING ELECTRIC SHOCK HAZARD	2	B93110060
2-9	C0551000903	DECAL; SETTING FOR OUTPUT VOLTAGE	1	C05100090
2-10	C2551000004	DECAL; SAFETY INSTRUCTIONS	1	C25100000
2-11	C0561103403	DECAL; WHISPERWATT 180	1	C06110340
ENGINE & RADIATOR GROUP				
3-1	1320610603	DECAL; WATER-OIL	1	S-1760
3-2	6360610304	DECAL; WATER	1	S-1880
3-3	6360620204	DECAL; OIL DRAIN PLUG	1	S-1885
3-4	B9504000304	DECAL; CAUTION HOT PARTS	1	B90400030
3-5	B9504000404	DECAL; WARNING MOVING PARTS	2	B90400040
3-6	B9504100104	DECAL; WARNING HOT COOLANT	1	B90410010
ENGINE OPERATING PANEL GROUP				
4-1	C0551000504	DECAL; BATTERY SWITCH	1	C05100050
4-2	C1552000013	DECAL; OPERATING PANEL	1	C15200001
4-3	C1552000104	DECAL; FUEL LEAK DETECTED	1	C15200010

DCA-180SSK — NAME PLATE AND DECALS

NAME PLATE AND DECALS

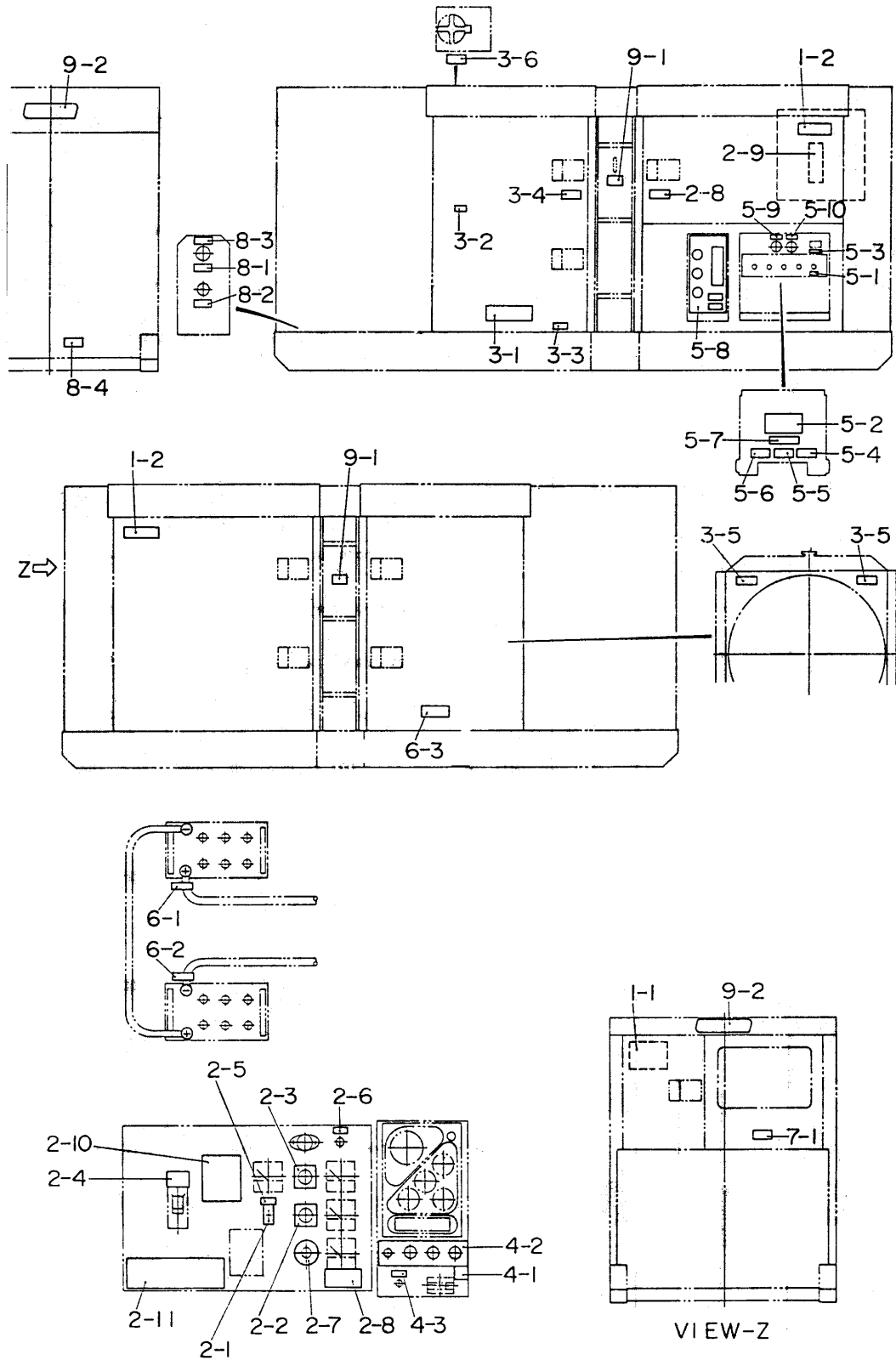

DCA-180SSK — NAME PLATE AND DECALS

NAME PLATE AND DECALS

<u>NO</u>	<u>PART NO</u>	<u>PART NAME</u>	<u>QTY.</u>	<u>REMARKS</u>
OUTPUT TERMINAL GROUP				
5-1	0840614104	DECAL; GROUND	1	S-2635
5-2	0840619904	DECAL; DANGER HIGH VOLTAGE	1	S-2731
5-3	9039209064	DECAL; START CONTACT	1	S-4468
5-4	B9511100304	DECAL; WARNING	1	B91110030
5-5	B9511100404	DECAL; WARNING ELECTRIC SHOCK HAZARD	1	B91110040
5-6	B9531100504	DECAL; WARNING ELECTRIC SHOCK HAZARD	1	B93110050
5-7	C0551000404	DECAL; 3-PHASE OUTPUT TERMINAL	1	C05100040
5-8	C0551001503	DECAL; RECEPTACLE & CIRCUIT BREAKER	1	C05100150
5-9	C1552000204	DECAL; WATER HEATER	1	C15200020
5-10	C1552000304	DECAL; BATTERY CHARGER	1	C15200030
BATTERY GROUP				
6-1	0800689404	DECAL; +	1	S-2090
6-2	0800689504	DECAL; -	1	S-2091
6-3	C9505300004	DECAL; CAUTION	1	C90530000
MUFFLER GROUP				
7-1	B9504200004	DECAL; WARNING ENGINE EXHAUST	1	B90420000
FUEL PIPING GROUP				
8-1	0800688404	DECAL; FUEL INLET	1	S-1344
8-2	0800688504	DECAL; FUEL OUTLET	1	S-1345
8-3	1320620904	DECAL; DIESEL FUEL	1	S-1756
8-4	B9504500004	DECAL; WARNING DIESEL FUEL	1	B90450000
ENCLOSURE GROUP				
9-1	1320621504	DECAL; SUPPORT HOOK	2	S-2257
9-2	0600500090	EMBLEM	2	
	0021106016	MACHINE SCREW	4	

PAYMENT TERMS

Terms of payment for parts are net 10 days.

FREIGHT POLICY

All parts orders will be shipped collect or prepaid with the charges added to the invoice. All shipments are F.O.B. point of origin. Multiquip's responsibility ceases when a signed manifest has been obtained from the carrier, and any claim for shortage or damage must be settled between the consignee and the carrier.

MINIMUM ORDER

The minimum charge for orders from Multiquip is \$15.00 net. Customers will be asked for instructions regarding handling of orders not meeting this requirement.

RETURNED GOODS POLICY

Return shipments will be accepted and credit will be allowed, subject to the following provisions:

1. A Returned Material Authorization must be approved by Multiquip prior to shipment.
2. To obtain a Return Material Authorization, a list must be provided to Multiquip Parts Sales that defines item numbers, quantities, and descriptions of the items to be returned.
 - a. The parts numbers and descriptions must match the current parts price list.
 - b. The list must be typed or computer generated.
 - c. The list must state the reason(s) for the return.
 - d. The list must reference the sales order(s) or invoice(s) under which the items were originally purchased.
 - e. The list must include the name and phone number of the person requesting the RMA.
3. A copy of the Return Material Authorization must accompany the return shipment.
4. Freight is at the sender's expense. All parts must be returned freight prepaid to Multiquip's designated receiving point.
5. Parts must be in new and resalable condition, in the original Multiquip package (if any), and with Multiquip part numbers clearly marked.
6. The following items are not returnable:
 - a. Obsolete parts. (If an item is listed in the parts price book as being replaced by another item, it is obsolete.)
 - b. Any parts with a limited shelf life (such as gaskets, seals, "O" rings, and other rubber parts) that were purchased more than six months prior to the return date.
 - c. Anyline item with an extended dealer net price of less than \$5.00.
 - d. Special order items.
 - e. Electrical components.
 - f. Paint, chemicals, and lubricants.
 - g. Decals and paper products.
 - h. Items purchased in kits.
7. The sender will be notified of any material received that is not acceptable.
8. Such material will be held for 5 working days from notification, pending instructions. If a reply is not received within 5 days, the material will be returned to the sender at his expense.
9. Credit on returned parts will be issued at dealer net price at time of the original purchase, less a 15% restocking charge.
10. In cases where an item is accepted for which the original purchase document can not be determined, the price will be based on the list price that was effective twelve months prior to the RMA date.
11. Credit issued will be applied to future purchases only.

PRICING AND REBATES

Prices are subject to change without prior notice. Price changes are effective on a specific date and all orders received on or after that date will be billed at the revised price. Rebates for price declines and added charges for price increases will not be made for stock on hand at the time of any price change.

Multiquip reserves the right to quote and sell direct to Government agencies, and to Original Equipment Manufacturer accounts who use our products as integral parts of their own products.

SPECIAL EXPEDITING SERVICE

A \$20.00 to \$50.00 surcharge will be added to the invoice for special handling including bus shipments, insured parcel post or in cases where Multiquip must personally deliver the parts to the carrier.

LIMITATIONS OF SELLER'S LIABILITY

Multiquip shall not be liable here under for damages in excess of the purchase price of the item with respect to which damages are claimed, and in no event shall Multiquip be liable for loss of profit or good will or for any other special, consequential or incidental damages.

LIMITATION OF WARRANTIES

No warranties, express or implied, are made in connection with the sale of parts or trade accessories nor as to any engine not manufactured by Multiquip. Such warranties made in connection with the sale of new, complete units are made exclusively by a statement of warranty packaged with such units, and Multiquip neither assumes nor authorizes any person to assume for it any other obligation or liability whatever in connection with the sale of its products. A part from such written statement of warranty, there are no warranties, express, implied or statutory, which extend beyond the description of the products on the face hereof.

PARTS AND OPERATION MANUAL

HERE'S HOW TO GET HELP

*PLEASE HAVE THE MODEL AND SERIAL NUMBER
ON-HAND WHEN CALLING*

PARTS DEPARTMENT

800/427-1244 or 310/537-3700

FAX: 800/672-7877 or 310/637-3284

SERVICE DEPARTMENT

800/835-2551 or 310/537-3700

FAX: 310/638-8046

WARRANTY DEPARTMENT

800/835-2551 or 310/537-3700

FAX: 310/638-8046

MAIN

800/421-1244 or 310/537-3700

FAX: 310/537-3927

Manufactured for Multiquip Inc.
by
DENYO MANUFACTURING CO., USA



MULTIQUIP INC.
POST OFFICE BOX 6254
CARSON, CA 90749
310-537-3700 • 800-421-1244
FAX: 310-537-3927
E-MAIL: mq@multiquip.com
WWW: multiquip.com

Atlanta • Boise • Dallas • Houston • Newark
Quebec, Canada • Manchester, UK • Rio De Janeiro, BR • Guadalajara, MX