

# **PARTS AND OPERATION MANUAL**

## **MQ POWER DCA-300SSK SERIES INCLUDES DCA-300SSK THRU DCA-300SSK III (STANDARD)**

© COPYRIGHT 2003, MULTIQIP INC.

**PARTS LIST NO. C2871300704  
SERIAL NO. 3708297~**

**Revision #3 (06/02/03)**



**MULTIQIP INC.**  
18910 WILMINGTON AVE.  
CARSON, CALIFORNIA 90746  
310-537-3700  
800-421-1244  
FAX: 310-537-3927  
E-mail: [mq@multiquip.com](mailto:mq@multiquip.com)

**PARTS DEPARTMENT:**  
800-427-1244  
FAX: 800-672-7877  
**SERVICE DEPARTMENT:**  
800-835-2551  
FAX: 310-638-8046  
[www.multiquip.com](http://www.multiquip.com)



# **WARNING**



## **CALIFORNIA — Proposition 65 Warning**

**Diesel engine exhaust and some of its constituents are known to the State of California to cause cancer, birth defects and other reproductive harm.**

## **HERE'S HOW TO GET HELP**

*PLEASE HAVE THE MODEL AND SERIAL  
NUMBER ON-HAND WHEN CALLING*

### ***PARTS DEPARTMENT***

*800-427-1244 or 310-537-3700*

*FAX: 800-672-7877 or 310-637-3284*

### ***SERVICE DEPARTMENT***

*800-421-1244*

*FAX: 310- 537-4259*

### ***TECHNICAL ASSISTANCE***

*800-478-1244*

*FAX: 310- 631-5032*

### ***WARRANTY DEPARTMENT***

*888-661-4279, or 310-661-4279*

*FAX: 310- 537-1173*

**MQPower DCA-300SSK  
SERIES AC Generator**

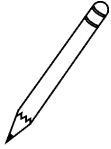
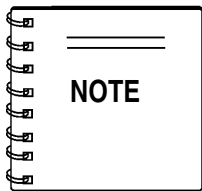
Here's How To Get Help ..... 3  
 Parts Ordering Procedures ..... 5  
 Specifications Generator/Engine ..... 6  
 Dimensions (Top and Side) ..... 8  
 Dimensions (Front Rear) ..... 9  
 Safety Alert Messages Symbols ..... 10  
 Rules for Safe Operation ..... 11-15  
 Installation ..... 16-17  
 Towing Rules for Safe Operation ..... 18  
 Trailer Safety Guidelines ..... 19  
 Trailer Specifications ..... 20-21  
 Operation and Safety Decals ..... 22-23  
 General Information ..... 24  
 Major Components ..... 25  
 Generator Control Panel (Up to S/N 3701673) ..... 26  
 Generator Control Panel (S/N 3701674~) ..... 26  
 Generator Control Panel Description ..... 27  
 Engine Operating Panel (Up to S/N 3701673) ..... 28  
 Engine Operating Panel (S/N 3701673~) ..... 28  
 Engine Operating Panel Description ..... 29  
 Output Terminal Panel Overview ..... 30-32  
 Load Application ..... 33  
 Generator Outputs ..... 34  
 Generator Outputs/Gauge Reading ..... 35  
 Output Terminal Panel Connections ..... 36-37  
 Pre Setup ..... 38-42  
 Generator Start-up Procedure (Key Switch) ..... 43-45  
 Generator Start-up Procedure (Manual MPEC) ..... 46  
 Generator Start-up Procedure (Auto MPEC) ..... 47  
 Generator Shutdown Procedure ..... 48  
 Maintenance ..... 50-54  
 Trailer Brakes Maintenance ..... 55  
 Trailer Maintenance ..... 56-57  
 Trailer Wiring Diagram ..... 58  
 Generator Wiring Diagram ..... 59  
 Engine Wiring Diagram (up to S/N3696506) ..... 60  
 Engine Wiring Diagram (S/N3696507 to 3701673) ..... 61  
 Engine Wiring Diagram (S/N3701674~) ..... 62

Engine Troubleshooting ..... 63-64  
 Generator Troubleshooting ..... 65  
 Engine Controller Troubleshooting (MPEC) ..... 66  
 Explanation of Codes in Remarks Column ..... 68  
 Suggested Spare Parts ..... 69

**COMPONENT DRAWINGS**

Generator Assembly ..... 70-73  
 Control Box Assembly ..... 76-79  
 Engine & Radiator Assembly (Up to S/N 3697258) ... 80-83  
 Engine & Radiator Assy. (S/N 3708270-3708296) ..... 84-85  
 Engine & Radiator Assembly (S/N 3708270~) ..... 86-89  
 Engine Operating Panel Assembly ..... 90-91  
 Output Terminal Assembly ..... 92-95  
 Actuator Assembly ..... 96-97  
 Battery Assembly ..... 98-99  
 Muffler Assembly ..... 100-101  
 Fuel Tank Assembly ..... 104-105  
 Enclosure Assembly (Up to S/N 3708296) ..... 106-109  
 Enclosure Assembly (Up to S/N 3708297~) ..... 110-115  
 Rubber Seal Assembly ..... 116-117  
 Oil Piping Assembly ..... 118-119  
 Name Plate and Decals ..... 120-125

Terms and Condition of Sale — Parts ..... 126



*Specification and part number are subject to change without notice.*

# PARTS ORDERING PROCEDURES

## When ordering parts, please supply the following information:

- Dealer account number
- Dealer name and address
- Shipping address (if different than billing address)
- Return fax number
- Applicable model number
- Quantity, part number and description of each part
- Specify preferred method of shipment:
  - ✓ FedEx or UPS Ground
  - ✓ FedEx or UPS Second Day or Third Day
  - ✓ FedEx or UPS Next Day
  - ✓ Federal Express Priority One
  - ✓ DHL
  - ✓ Truck

*Note: Unless otherwise indicated by customer, all orders are treated as "Standard Orders", and will ship within 24 hours. We will make every effort to ship "Air Shipments" the same day that the order is received, if prior to 2PM west coast time. "Stock Orders" must be so noted on fax or web forms.*



## Here's how to get help...

*Please have the model and serial number on hand when calling.*

### Parts Department

800-427-1244 Fax: 800-672-7877  
310-537-3700 Fax: 310-637-3284

### Mayco Parts

800-306-2926 Fax: 800-672-7877  
310-537-3700 Fax: 310-637-3284

### Service Department

800-478-1244 Fax: 310-537-4259  
310-537-3700

### MQ Power Service Department

800-835-2551 Fax: 310-638-8046  
310-537-3700

### Warranty Department

800-421-1244, Ext. 279 Fax: 310-537-1173  
310-537-3700, Ext. 279

### Multiquip's Main Phone Numbers

800-421-1244 Fax: 310-537-3927  
310-537-3700

## Place Your Parts Order Via Web or Fax For Even More Savings!

### Extra Discounts!

All parts orders which include complete part numbers and are received by our automated web parts order system, or by fax qualify for the following extra discounts:

Ordered via	Standard orders	Stock orders (\$750 list and above)
Fax	3%	10%
Web	5%	10%

### Special freight allowances when you order 10 or more line items via Web or Fax! \*\*

FedEx Ground Service **at no charge for freight**

*No other allowances on freight shipped by any other carrier.*

NOTE: DISCOUNTS ARE SUBJECT TO CHANGE



**MULTIQUIP INC.**  
18910 WILMINGTON AVENUE  
POST OFFICE BOX 6254  
CARSON, CALIFORNIA 90749  
310-537-3700 • 800-421-1244  
FAX: 310-537-3927  
E-MAIL: mq@multiquip.com  
WWW: multiquip.com

## Direct TOLL-FREE access to our Parts Department:

Toll-free nationwide — 800-427-1244

# DCA-300SSK SERIES — SPECIFICATIONS

**Table 1. Generator Specifications**

Design	Revolving field,Self-ventilated Drip-proof-Single bearing
No. of Poles	4-pole
Excitation	Brushless with AVR
Standby Output	264 KW (330 KVA)
Prime Output	240 KW (300 KVA)
Generator RPM	1800
Voltage — 3Ø	208, 220, 240, 416, 440, 480V Reconnectable
Voltage — 1Ø	120, 127, 139, 240, 254, 277V Adjustable
Armature Connection	Star with neutral
Voltage Regulation (No load to full load)	±1.5%
Power Factor	0.8
Frequency	60 Hz
Frequency Regulation: No load to full load	Isochronous under varying loads from no load to 100% rated load
Frequency Regulation: Steady State	±0.25% of mean value for constant loads from no load to full load
Insulation	Class F
Sound Level dB(A) Full load at 23 feet	71
Dimensions Approx. (L x W x H)	153 x 56 x 71 in. (389 x 142 x 180 mm.)
Dry Net Weight	9,172 lbs. (4,160 kg.)

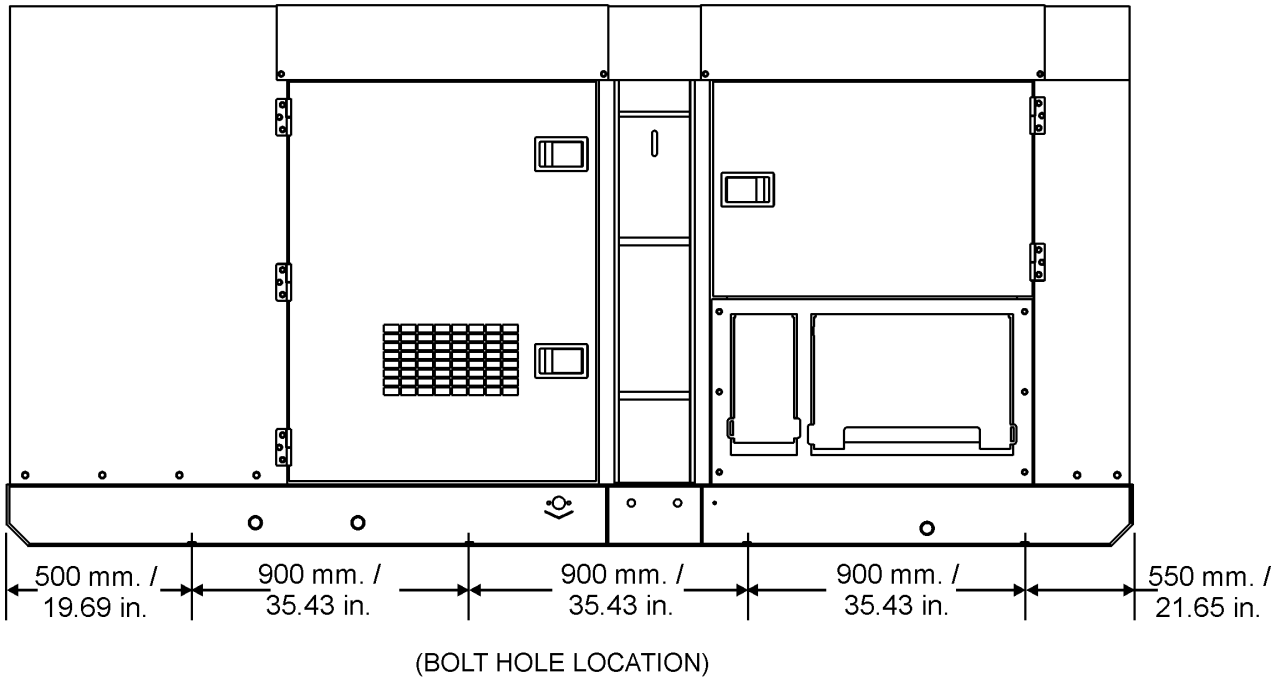
**Table 2. Engine Specifications**

Model	KOMATSU SA6D125E-2	KOMATSU SAA6D125E-2
Type	4 Cycle, water-cooled, direct injection, turbocharged with after-cooler	4 Cycle, water-cooled, direct injection, turbocharged with air to air after-cooler
No. of Cylinders	6 cylinders	
Bore x Stroke	4.9 in. x 5.9 in. (125 mm x 150 mm)	
Rated Output	345hp/1800 rpm	354hp/1800 rpm
Displacement	673 cu. in. (11,040 cc)	
Starting	Electric	
Coolant Capacity	8.5 gal. (32.6 liters)	9.8 gal. (37 liters)
Lube Oil Capacity	16.1 gal. (60 liters)	16.4 gal. (62 liters)
Fuel Consumption	17.5 gal. (66.5L)/hr at full load	16.7gal. (63.2L)/hr at full load
Battery	12V- 150AH x 2	
Fuel	#2 Diesel Fuel	



# DCA-300SSK SERIES — DIMENSIONS (TOP AND SIDE)

## SIDE VIEW



## TOP VIEW

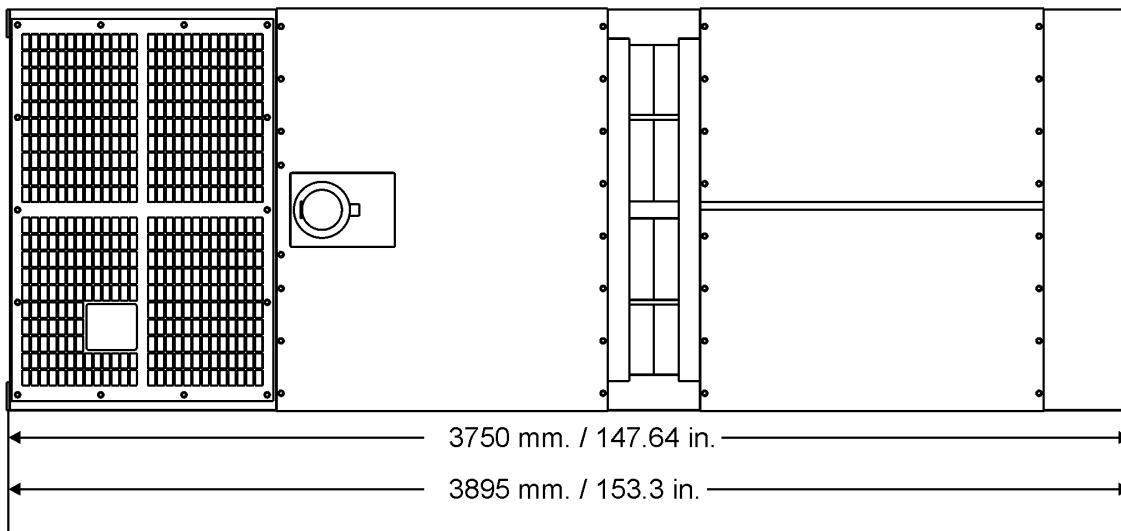


Figure 1. Dimensions (Side and Top Views)

# DCA-300SSK SERIES — DIMENSIONS (FRONT AND REAR)

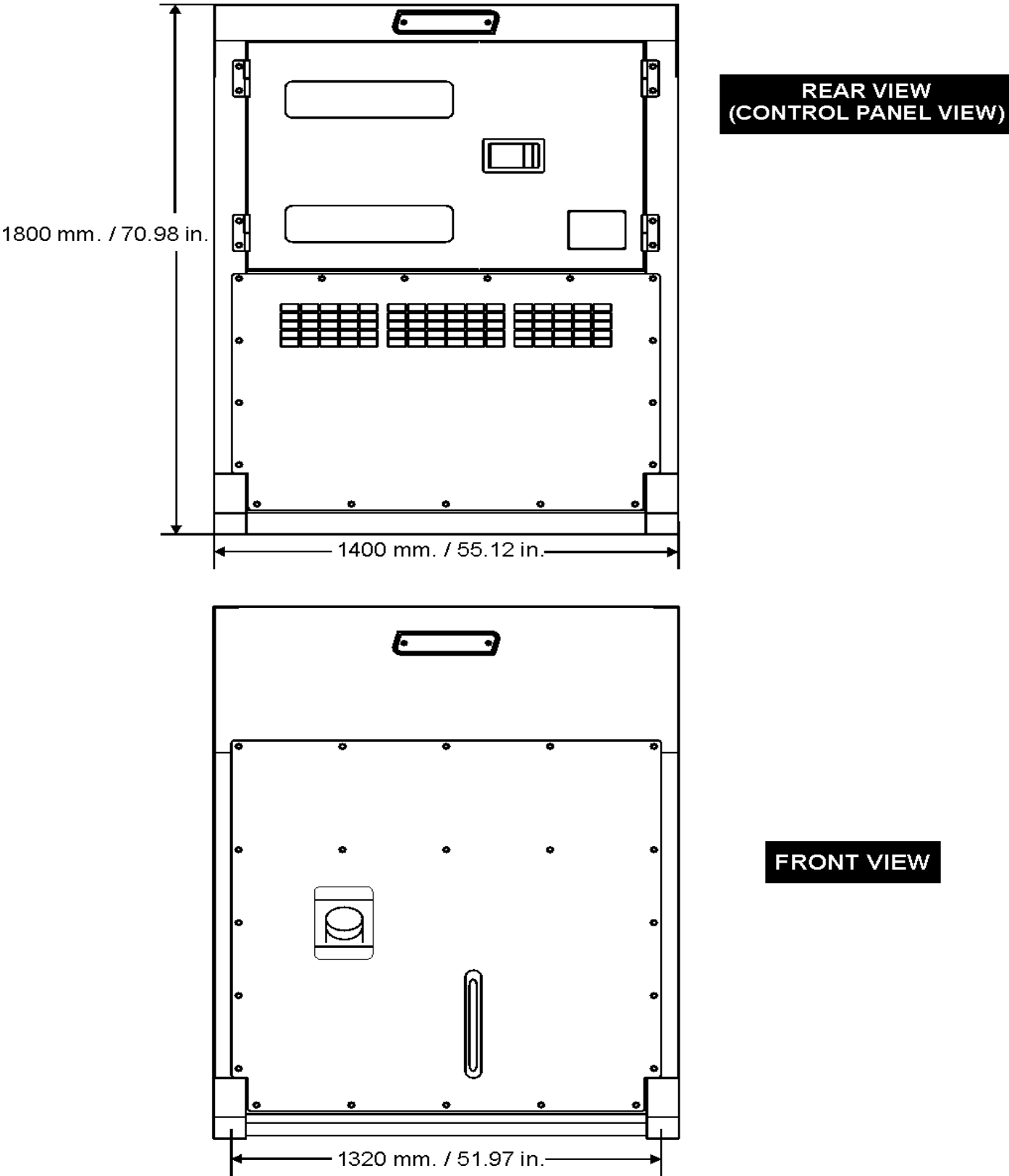
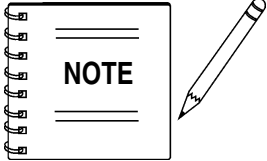


Figure 2. Dimensions (Rear and Front Views)

# DCA-300SSK SERIES — SAFETY MESSAGE ALERT SYMBOLS

## FOR YOUR SAFETY AND THE SAFETY OF OTHERS!

Safety precautions should be followed at all times when operating this equipment. Failure to read and understand the Safety Messages and Operating Instructions could result in injury to yourself and others.



This Owner's Manual has been developed to provide complete instructions for the safe and efficient operation of the MQ Power *Model DCA300SSK SERIES WHISPERWATT™ GENERATORS*. Before using these GENERATORS, ensure that the operating individual has read and understands all instructions in this manual.

## SAFETY MESSAGE ALERT SYMBOLS

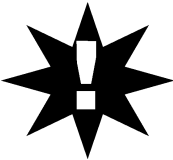
The three (3) Safety Messages shown below will inform you about potential hazards that could injure you or others. The Safety Messages specifically address the level of exposure to the operator, and are preceded by one of three words: **DANGER**, **WARNING**, or **CAUTION**.



**DANGER:** You **WILL** be **KILLED** or **SERIOUSLY** injured if you **DO NOT** follow directions.



**WARNING:** You **CAN** be **KILLED** or **SERIOUSLY** injured if you **DO NOT** follow directions.



**CAUTION:** You **CAN** be injured if you **DO NOT** follow directions.

Potential hazards associated with the DCA300SSK series generators operation will be referenced with Hazard Symbols which appear throughout this manual, and will be referenced in conjunction with Safety Message Alert Symbols.

## HAZARD SYMBOLS

### Rotating Parts



**NEVER** operate equipment with covers, or guards removed. Keep fingers, hands, hair and clothing away from all moving parts to prevent injury.

### Accidental Starting



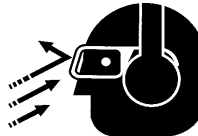
**ALWAYS** place the power source, circuit breakers or **ON/OFF** switch in the **OFF** position, when the generator is not in use, unless connected to transfer switch.

### Over-Speed Conditions



**NEVER** tamper with the factory settings of the engine governor settings. Personal injury and damage to the engine or equipment can result if operating speed ranges above maximum allowable.

### Sight and Hearing Hazard



**ALWAYS** wear approved **eye** and **hearing** protection when required.

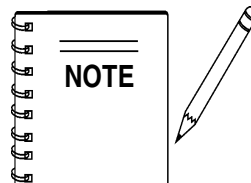
### Respiratory Hazard



**ALWAYS** wear approved **respiratory** protection when required.

### Equipment Damage Messages

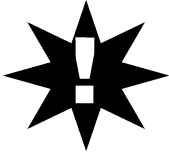
Other important messages are provided throughout this manual to help prevent damage to your generator, other property, or the surrounding environment.



This generator, other property, or the surrounding environment could be damaged if you do not follow instructions.

# DCA-300SSK SERIES — RULES FOR SAFE OPERATION

## CAUTION:



Failure to follow instructions in this manual may lead to serious injury or even death! This equipment is to be operated by trained and qualified personnel only! This equipment is for industrial use only.

The following safety guidelines should always be used when operating the **DCA-300SSK SERIES Generators**:

### GENERAL SAFETY

- **DO NOT** operate or service this equipment before reading this entire manual.



- This equipment should not be operated by persons under 18 years of age.

- **NEVER** operate this equipment without proper protective clothing, shatterproof glasses, steel-toed boots and other protective devices required by the job.



- **NEVER** operate this equipment when not feeling well due to fatigue, illness or taking medicine.



- **NEVER** operate this equipment under the influence of drugs or alcohol.



- **NEVER** use accessories or attachments, which are not recommended by MQ Power for this equipment. Damage to the equipment and/or injury to user may result.

- Manufacture does not assume responsibility for any accident due to equipment modifications.

- Whenever necessary, replace nameplate, operation and safety decals when they become difficult read.

- **ALWAYS** check the machine for loosened threads or bolts before starting.

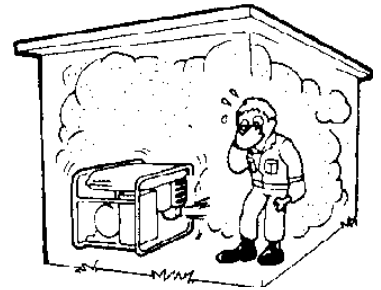
- **NEVER** operate the generator in an explosive atmosphere or near combustible materials. An explosion or fire could result causing severe **bodily harm or even death**.

- **NEVER** touch the hot exhaust manifold, muffler or cylinder. Allow these parts to cool before servicing engine or generator.



- **High Temperatures** – Allow the engine to cool before performing service and maintenance functions. Contact with **hot!** components can cause serious burns.

- The engine of this generator requires an adequate free flow of cooling air. **NEVER** operate the generator in any enclosed or narrow area where free flow of the air is restricted. If the air flow is restricted it will cause serious damage to the generator or engine and may cause injury to people. The generator engine gives off **DEADLY** carbon monoxide gas.



- **ALWAYS** make sure generator is properly grounded.

- **NEVER** use gas piping as an electrical ground.

- **DO NOT** place hands or fingers inside generator engine compartment when engine is running.

- **ALWAYS** make sure generator installation is accordance with **national and local electrical codes**.

- **ALWAYS** have a qualified electrician perform the pump wiring installation.

- **NEVER** let power cables or cords **lay in water**.

- **NEVER stand in water** while AC power from the generator is being transfer to a load.

- **NEVER** use a defective or frayed power cable. Check the cable for cuts in the insulation.

- **NEVER** use a extension cord that is frayed or damaged where the insulation has been cut.

- **ALWAYS** make certain that proper extension cord has been selected for the job See Table 6.

- The electrical voltage required to operate the generator can cause severe injury or even death through physical contact with live circuits. Turn all circuit breakers **OFF** before performing maintenance on the generator.

# DCA-300SSK SERIES — RULES FOR SAFE OPERATION

■ **ALWAYS** make sure that electrical circuits are properly **grounded** per the **National Electrical Code (NEC)** and local codes before operating generator. Severe **injury** or **death!** by electrocution can result from operating an ungrounded generator.

■ **ALWAYS** be sure the operator is familiar with proper safety precautions and operations techniques before using generator.

■ **ALWAYS** store equipment properly when it is not being used. Equipment should be stored in a clean, dry location out of the reach of children.

■ **ALWAYS** read, understand, and follow procedures in Operator's Manual before attempting to operate equipment.



## DANGER:



**NEVER** use **damaged** or **worn** cables when connecting equipment to the generator. Make sure power connecting

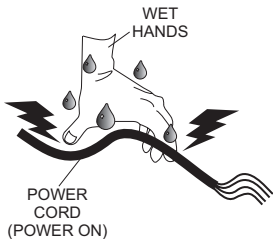


cables are securely connected to the generator's output terminals, insufficient tightening of the terminal connections may cause damage to the generator and electrical shock.

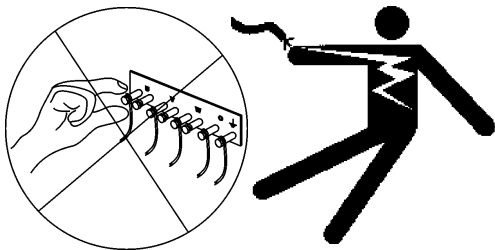
## DANGER:



**NEVER** grab or touch a live power cord with wet hands, the possibility exist of electrical shock, electrocution, and even **death!**

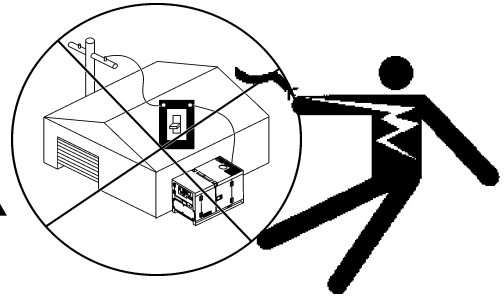


## DANGER:



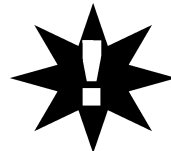
■ **NEVER** touch output terminals during operation. This is extremely dangerous. **ALWAYS** stop the generator and place the **main** circuit breaker in the "**OFF**" position when contact with the output terminals is required. There exist the possibility of **electrocution, electrical shock or burn, which can cause severe bodily harm or even death!**

## DANGER:



■ Backfeed to a utility system can cause **electrocution** and or property damage. **DO NOT** connect to any building's electrical system except through an approved device or after building main switch is opened. **ALWAYS** have a licensed electrician perform the installation

## CAUTION:



**DO NOT** touch or open any of the below mentioned components while the generator is running. Always allow sufficient time for the engine and generator to cool before performing maintenance.

### Radiator

1. **Radiator Cap** - Removing the radiator cap while the engine is hot will result in high pressurized, boiling water to gush out of the radiator, causing severe scalding to any persons in the general area of the generator.
2. **Coolant Drain Plug** - Removing the coolant drain plug while the engine is hot will result in hot coolant to gush out of the coolant drain plug, therefore causing severe scalding to any persons in the general area of the generator.
3. **Engine Oil Drain Plug** - Removing the engine oil drain plug while the engine is hot will result in hot oil to gush out of the oil drain plug, therefore causing severe scalding to any persons in the general area of the generator.

### Maintenance Safety

■ **NEVER** lubricate components or attempt service on a running machine.

■ **ALWAYS** allow the machine a proper amount of time to cool before servicing.



■ Keep the machinery in proper running condition.

■ Fix damage to the machine immediately and always replace broken parts.

# DCA-300SSK SERIES — RULES FOR SAFE OPERATION

- **NEVER** Run engine without air filter. Severe engine damage may occur.
- **ALWAYS** service air cleaner frequently to prevent engine malfunction.
- **ALWAYS** disconnect the **negative battery terminal** before performing service on the generator.
- **ALWAYS** be sure the operator is familiar with proper safety precautions when operating the generator set.
- **ALWAYS** store equipment properly when not in use.
- **DO NOT** leave the generator running in the **manual mode** unattended.
- **DO NOT** allow **unauthorized personnel** to operate this equipment.
- **ALWAYS** read, understand, and follow procedures in Operator's Manual before attempting to operate equipment.
- Refer to the **Komatsu Engine Manual** for engine technical questions or information.

## DANGER:



Pay close attention to ventilation when operating the generator inside tunnels and caves. The engine exhaust contains noxious elements. Engine exhaust must be routed to a ventilated area.



## Generator Grounding

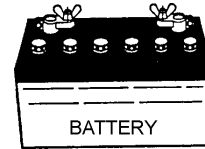
To guard against electrical shock and possible damage to the equipment, it is important to provide a good **EARTH** ground.

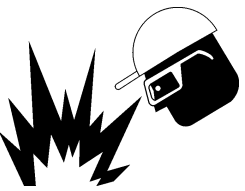
Article 250 (Grounding) of the **National Electrical Code** (NEC) provides guide lines for proper grounding and specifies that the cable ground shall be connected to the grounding system of the building as close to the point of cable entry as practical.

**ALWAYS** be sure to use the ground terminal (green wire) when connecting a load to the UVWO output terminals.

## Battery

The battery contains acids that can cause injury to the eyes and skin. To avoid eye irritation, **always** wear safety glasses. Use well insulated gloves when picking up the battery. Use the following guidelines when handling the battery:



1. **DO NOT** drop the battery. There is the possibility of risk that the battery may explode.
2. **DO NOT** expose the battery to open flames, sparks, cigarettes etc. The battery contains combustible gases and liquids. If these gases and liquids come in contact with a flame or spark, an explosion could occur. 
3. **ALWAYS** keep the battery charged. If the battery is not charged a buildup of combustible gas will occur.
4. **ALWAYS** keep battery charging and cables in good working condition. Repair or replace all worn cables.
5. **ALWAYS** recharge the battery in an vented air environment, to avoid risk of a dangerous concentration of combustible gases.
6. In case the battery liquid (dilute sulfuric acid) comes in contact with **clothing or skin**, rinse skin or clothing immediately with plenty of water.
7. In case the battery liquid (dilute sulfuric acid) comes in contact with your **eyes**, rinse eyes immediately with plenty of water, then contact the nearest doctor or hospital, and seek medical attention.

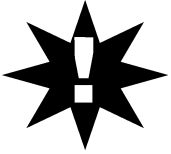
## Transporting

- **ALWAYS** shutdown engine before transporting.
- Tighten both fuel tank caps securely.
- If generator is mounted on a trailer, make sure trailer complies with all local and state safety transportation laws. See next page "**Towing Safety Precautions**" for basic towing techniques.

# DCA-300SSK SERIES — RULES FOR SAFE OPERATION

## Towing Safety Precautions

### CAUTION:



Conform to **Department of Transportation (DOT) Safety Towing Regulations** before towing generator.

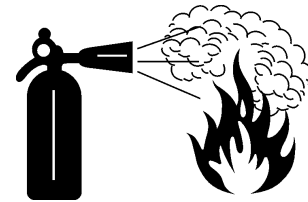
To reduce the possibility of an accident while transporting the generator on public roads, always make sure the trailer that supports the generator and the towing vehicle are in good operating condition and both units are mechanically sound.

The following list of suggestions should be used when towing your generator:

- Make sure the hitch and coupling of the towing vehicle are rated equal to, or greater than the trailer "gross vehicle weight rating" (GVWR) of 18,000 lbs.
  - **ALWAYS** inspect the hitch and coupling for wear. **NEVER** tow a trailer with defective hitches, couplings, chains etc.
  - Check the tire air pressure on both towing vehicle and trailer. **Trailer tires should be inflated to 50 psi cold.** Also check the tire tread wear on both vehicles.
  - **ALWAYS** make sure the trailer is equipped with a "Safety Chain".
  - **ALWAYS** attach trailer's safety chains to towing vehicle properly.
  - **ALWAYS** make sure the vehicle and trailer directional, backup, brake, and trailer lights are connected and working properly.
  - The maximum speed for highway towing is **45 MPH** unless posted otherwise. Recommended off-road towing is not to exceed **10 MPH** or less depending on type of terrain.
  - Place **chock blocks** underneath wheel to prevent **rolling**, while parked.
  - Use the trailer's swivel jack to adjust the trailer height to a level position while parked.
  - Avoid sudden stops and starts. This can cause skidding, or jack-knifing. Smooth, gradual starts and stops will improve towing.
- Avoid sharp turns.
  - Trailer should be adjusted to a level position at all times when towing.
  - Raise and lock trailer wheel stand in up position when transporting.
  - DOT Requirements include the following:
    - Connect and test electric brake operation.
    - Secure portable power cables in cable tray with tie wraps.

### Emergencies

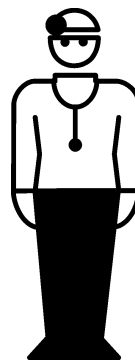
- **ALWAYS** know the location of the nearest **fire extinguisher**.



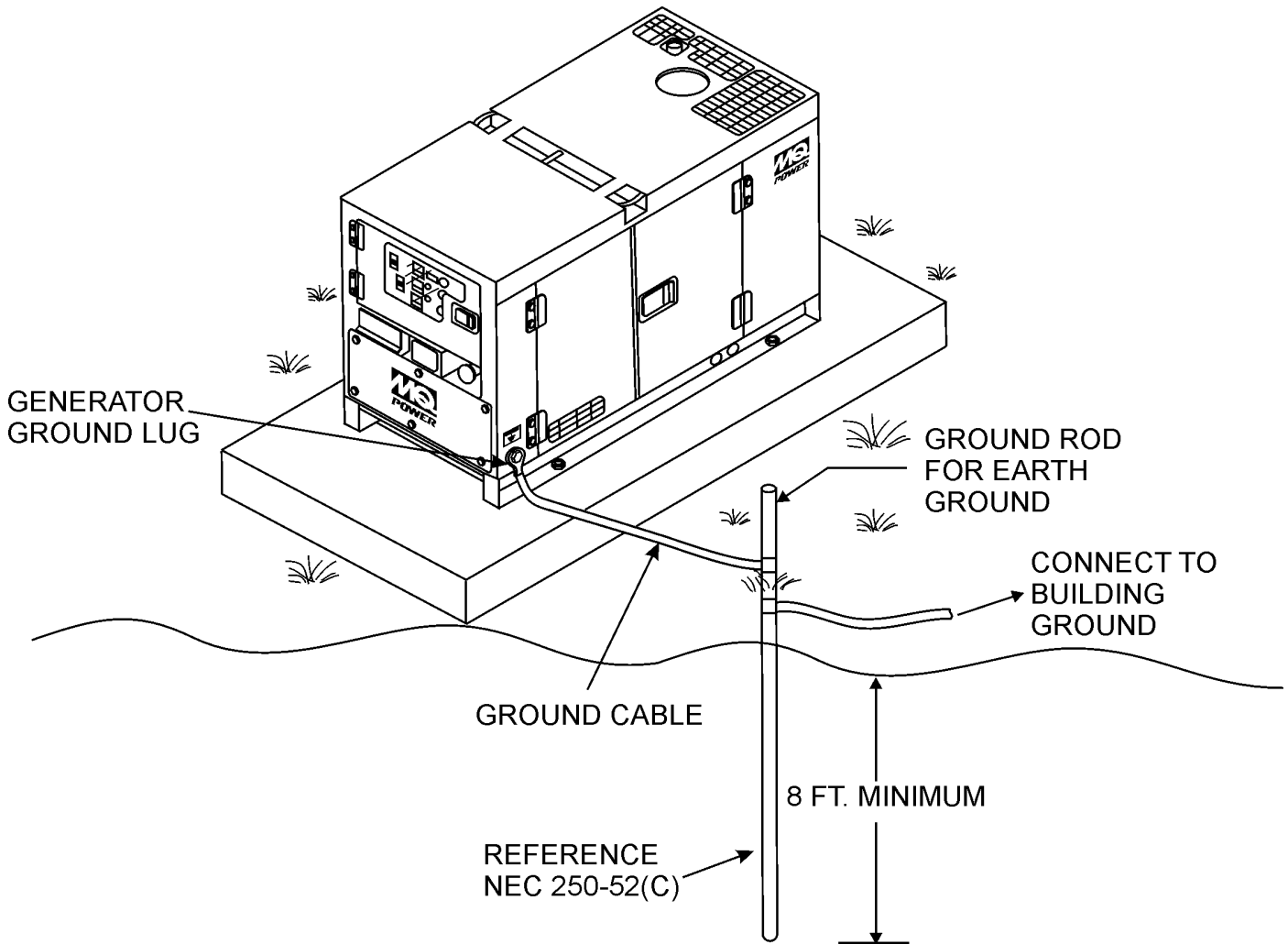
- **ALWAYS** know the location of the nearest **first aid kit**.



- In emergencies **always** know the location of the nearest phone or **keep a phone on the job site**. Also know the phone numbers of the nearest **ambulance, doctor and fire department**. This information will be invaluable in the case of an emergency.







**Figure 3. Typical Generator Grounding Application**

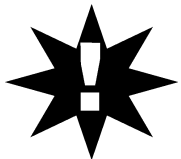
## Outdoor Installation

Install the generator in a area that is free of **debris**, **bystanders**, and **overhead obstructions**. Make sure the generator is on secure level ground so that it cannot slide or shift around. Also install the generator in a manner so that the exhaust will not be discharged in the direction of nearby homes.

The installation site must be relatively free from moisture and dust. All electrical equipment should be protected from excessive moisture. Failure to do will result in deterioration of the insulation and will result in short circuits and grounding.

Foreign materials such as dust, sand, lint and abrasive materials have a tendency to cause excessive wear to engine and alternator parts.

## CAUTION:



Pay close attention to ventilation when operating the generator inside tunnels and caves. The engine exhaust contains noxious elements. Engine exhaust must be routed to a ventilated area.

## Indoor Installation

Exhaust gases from diesel engines are extremely poisonous. Whenever an engine is installed indoors the exhaust fumes must be vented to the outside. The engine should be installed at least two feet from any outside wall. Using an exhaust pipe which is too long or too small can cause excessive back pressure which will cause the engine to heat excessively and possibly burn the valves.

## Mounting

The generator must be mounted on a solid foundation (such as concrete) and set firmly on the foundation to isolate vibration of the generator when it is running. The generator must set at least 6 inches above the floor or grade level (in accordance to NFPA 110, Chapter 5-4.1). **DO NOT** remove the metal skids on the bottom of the generator. They are to resist damage to the bottom of the generator and to maintain alignment.

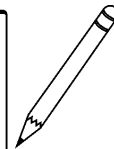
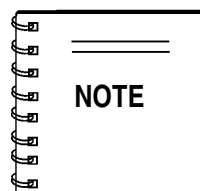
## Generator Grounding

To guard against electrical shock and possible damage to the equipment, it is important to provide a good **EARTH** ground.

Article 250 (Grounding) of the National Electrical Code (NEC) provides guide lines for proper grounding and specifies that the cable ground shall be connected to the grounding system of the building as close to the point of cable entry as practical.

NEC articles 250-64(b) and 250-66 set the following grounding requirements:

1. Use one of the following wire types to connect the generator to earth ground.
  - a. Copper - 10 AWG (5.3 mm<sup>2</sup>) or larger.
  - b. Aluminum - 8 AWG (8.4 mm<sup>2</sup>) or larger.
2. When grounding the generator (Figure 3) connect the ground cable between the lock washer and the nut on the generator and tighten the nut fully. Connect the other end of the ground cable to earth ground.
3. NEC article 250-52(c) specifies that the earth ground rod should be buried a minimum of 8 ft. into the ground.

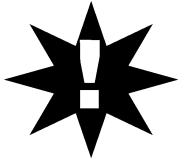


When connecting the generator to any buildings electrical system **ALWAYS** consult with a licensed electrician.

# DCA-300SSK SERIES — TOWING RULES FOR SAFE OPERATION

## Towing Safety Precautions

### CAUTION:



Check with your local county or state safety towing regulations before towing your generator.

To reduce the possibility of an accident while transporting the generator on public roads, always make sure the trailer (Figure 4) that supports the generator and the towing vehicle are in good operating condition and both units are mechanically sound.

The following list of suggestions should be used when towing your generator:

- Make sure the hitch and coupling of the towing vehicle are rated equal to, or greater than the trailer "gross vehicle weight rating" (GVWR).
- **ALWAYS** inspect the hitch and coupling for wear. **NEVER** tow a trailer with defective hitches, couplings, chains etc.
- Check the tire air pressure on both towing vehicle and trailer. Also check the tire tread wear on both vehicles.
- **ALWAYS** make sure the trailer is equipped with a "Safety Chain".
- **ALWAYS** attach trailer's safety chain to bumper of towing vehicle.
- **ALWAYS** make sure the vehicle and trailer directional, backup, brake, and trailer lights are connected and working properly.
- The maximum speed for highway towing is **55 MPH** unless posted otherwise. Recommended off-road towing is not to exceed **15 MPH** or less depending on type of terrain.
- Place *chocked blocks* underneath wheel to prevent **rolling**, while parked.
- Place *support blocks* underneath the trailer's bumper to prevent **tipping**, while parked.
- Use the trailer's hand winch to adjust the height of the trailer, then insert locking pin to lock wheel stand in place, while parked.
- Avoid sudden stops and starts. This can cause skidding, or jackknifing. Smooth, gradual starts and stops will improve gas mileage.
- Avoid sharp turns to prevent rolling.
- Remove wheel stand when transporting.
- **DO NOT** transport generator with fuel in tank.

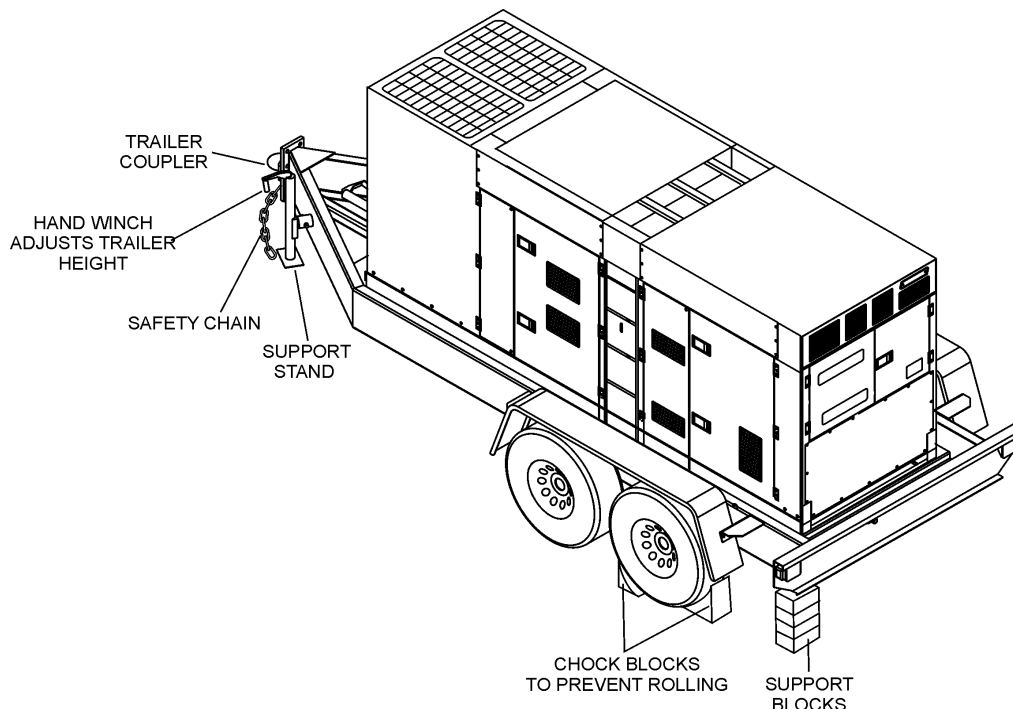
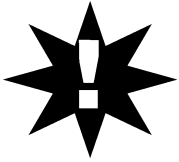


Figure 4. Generator with Trailer

## CAUTION:



**ALWAYS** make sure the trailer is in good operating condition. Check the tires for proper inflation and wear. Also check the wheel lug nuts for proper tightness.

### Explanation of Chart:

This section is to provide the user with trailer service and maintenance information. The service and maintenance guidelines referenced in this section apply a wide range of trailers. Remember periodic inspection of the trailer will ensure safe towing of the equipment and will prevent damage to the equipment and personal injury.

It is the purpose of this section to cover the major maintenance components of the trailer. The following trailer components will be discussed in this section:

- Brakes
- Tires
- Lug Nut Torquing
- Suspension
- Electrical
- Brake Troubleshooting Tables

Use the following definitions when reading Table 3.

1. **Fuel Cell** - Provides an adequate amount of fuel for the equipment in use. Fuel cells must be empty when transporting equipment.
2. **Braking System** - System employed in stopping the trailer. Typical braking systems are electric, surge, hydraulic, hydraulic-surge and air.
3. **GVWR**- Gross Vehicle Weight Rating (GVWR), is the maximum number of pounds the trailer can carry, including the fuel cell (empty).
4. **Frame Length** - Measurement is from the ball hitch to the rear bumper (reflector).
5. **Frame Length** - Measurement is from fender to fender
6. **Jack Stand** - Trailer support device with maximum pound requirement from the tongue of the trailer.
7. **Coupler** - Type of hitch used on the trailer for towing.
8. **Tire Size** - Indicates the diameter of the tire in inches (10,12,14, etc.), and the width in millimeters (175,185,205, etc.). The tire diameter must match the diameter of the tire rim.
9. **Tire Ply** - The tire ply (layers) number is rated in letters; 2-ply,4-ply,6-ply, etc.
10. **Wheel Hub** - The wheel hub is connected to the trailer's axle.
11. **Tire Rim** - Tires mounted on a tire rim. The tire rim must match the size of the tire.
12. **Lug Nuts** - Used to secure the wheel to the wheel hub. Always use a torque wrench to tighten down the lug nuts. See Table 17 and Figure 67 for lug nut tightening and sequence.
13. **Axle** - Indicates the maximum weight the axle can support in pounds, and the diameter of the axle expressed in inches. Please note that some trailers have a double axle. This will be shown as 2-6000 lbs., meaning two axles with a total weight capacity of 6000 pounds.
14. **Suspension** - Protects the trailer chassis from shocks transmitted through the wheels. Types of suspension used are leaf, Q-flex, and air ride.
15. **Electrical** - Electrical connectors (looms) are provided with the trailer so the brake lights and turn signals can be connected to the towing vehicle.
16. **Application** - Indicates which units can be employed on a particular trailer.

# DCA-300SSK SERIES —TRAILER-SPECIFICATIONS

**Table 3. Trailer Specifications**

MODEL	APPLICATION	FUEL CELL	BRAKE SYSTEM	GVWR	FRAME LENGTH	FRAME WIDTH	JACK STAND
TRLR-10W	SDW225, SGW250,TLW300	NO	NO	1,900 LBS. 862 Kg.	96 inches 2.43 meters	50 inches 1.27 meters	800 LBS. (363 Kg.) FULL TILT WHEEL
TRLR-10	DCA10, TLG12, DCA-15	NO	NO	1,900 LBS. 862 Kg.	96 inches 2.43 meters	50 inches 1.27 meters	800 LBS. (363 Kg.) FULL TILT WHEEL
TRLR-10XF	DCA10, TLG-12, DCA15, TLW-300	52 Gallons 197 Liters	NO	1,900 LBS. 862 Kg.	96 inches 2.43 meters	50 inches 1.27 meters	800 LBS. (363 Kg.) FULL TILT WHEEL
TRLR-225W	WELDERS, DA7000SS	NO	NO	2,200 LBS. 998 Kg.	85 inches 2.43 meters	42 inches 1.06 meters	800 LBS. (363 Kg.) FULL TILT WHEEL
TRLR-BLW400	BLW-400	NO	ELECTRIC	2,700 LBS. 1,224 Kg.	W/MAST 154 in. 3.19 meters W/O 124 in. 3.14 meters	55 inches 1.40 meters (78 inches TALL) 1.98 meters	800 LBS. (363 Kg.) FULL TILT WHEEL
TRLR-50X	DCA-25	NO	NO	2,700 LBS. 1,224 Kg.	124 inches 3.14 meters	55 inches 1.40 meters	800 LBS. (363 Kg.) FULL TILT WHEEL
TRLR-50XF	DCA-25	41 Gallons 155 Liters	NO	2,700 LBS. 1,224 Kg.	124 inches 3.14 meters	55 inches 1.40 meters	800 LBS. (363 Kg.) FULL TILT WHEEL
TRLR-70W	DCA-45, -60, 70	NO	SURGE	7,000 LBS. 3,175 Kg.	186 inches 4.72 meters	77 inches 1.95 meters	2,000 LBS. (907 Kg.) FLAT PAD
TRLR-70X	DCA-45, -60, 70	OPT	SURGE	7,000 LBS. 3,175 Kg.	138 inches 3.50 meters	66 inches 1.67 meters	2,000 LBS. (907 Kg.) FLAT PAD
TRLR-70XF	DCA-45, -60, 70	53 Gallons 201 Liters	SURGE	7,000 LBS. 3,175 Kg.	138 inches 3.50 meters	66 inches 1.67 meters	2,000 LBS. (907 Kg.) FLAT PAD
TRLR-100XF	DCA-100, 125	150 Gallons 568 Liters	HYDRAULIC SURGE	7,000 LBS. 3,175 Kg.	190 inches 4.82 meters	76 inches 1.93 meters	2,000 LBS. (907 Kg.) FLAT PAD
TRLR-85/125	DCA-85, 100, 125	145 Gallons 549 Liters	HYDRAULIC	10,000 LBS. 4,536 Kg.	186 inches 4.72 meters	77 inches 1.95 meters	2,000 LBS. (907 Kg.) FLAT PAD
TRLR-150XF	DCA-150, 180	200 Gallons 757 Liters	HYDRAULIC SURGE	11,160 LBS. 5,062 Kg.	204 inches 5.18 meters	84 inches 2.13 meters	5,000 LBS. (2,268 Kg.) FLAT PAD
TRLR-220XF	DCA-220	250 Gallons 946 Liters	HYDRAULIC SURGE	14,000 LBS. 3,175 Kg.	222 inches 3.63 meters	83 inches 2.10 meters	5,000 LBS. (2,268 Kg.) FLAT PAD
TRLR-300XF	DCA-300	250 Gallons 946 Liters	HYDRAULIC SURGE	18,000 LBS. 8,165 Kg.	238 inches 6.04 meters	83 inches 2.10 meters	5,000 LBS. (2,268 Kg.) FLAT PAD
TRLR-400XF	DCA-400	350 Gallons 1,324 Liters	ELECTRIC	18,000 LBS. 8,165 Kg.	238 inches 6.04 meters	83 inches 2.10 meters	5,000 LBS. (2,268 Kg.) FLAT PAD
TRLR-600XF	DCA-600, 800	550 Gallons 2,082 Liters	AIR	30,000 LBS. 13,607 Kg.	384 inches 9.75 meters	96 inches 2.43 meters	5,000 LBS. (2,268 Kg.) FLAT PAD
TRLR-800SX	DCA-600, 800	550 Gallons 2,082 Liters	AIR	30,000 LBS. 13,607 Kg.	384 inches 9.75 meters	96 inches 2.43 meters	5,000 LBS. (2,268 Kg.) FLAT PAD

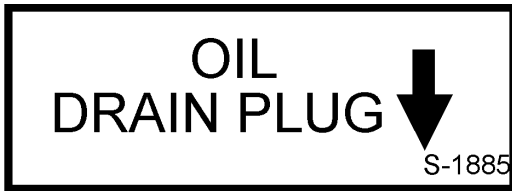
# DCA-300SSK SERIES —TRAILER-SPECIFICATIONS

**Table 3. Specifications (Con't)**

MODEL	COUPLER	TIRES	WHEELS	AXLE	HUBS	SUSPENSION	ELECTRICAL
TRLR-10W	2" BALL CLASS 2 ADJUSTABLE	175-13C	13"X4.50"	2200# 2X2	5 LUG	3 LEAF	4 WIRE LOOM W/ 4 POLE FLAT
TRLR-10	2"BALL CLASS 2 ADJUSTABLE	175-13C	13"X4.5"	2200#2X2	5 LUG	3 LEAF	4 POLE FLAT
TRLR-10XF	2"BALL CLASS 2 ADJUSTABLE	175-13C	13"X4.5"	2200#2X2	5 LUG	3 LEAF	4 POLE FLAT
TRLR-225W	2"BALL CLASS 2 ADJUSTABLE	175-13B	13X4.5"	2200#2X2	5 LUG	Q FLEX	4 POLE FLAT
TRLR-BLW 400	2"BALL CLASS 2 ADJUSTABLE	175-13C	13 X 4.5"	2200#2X2	5 LUG	3 LEAF	4 POLE FLAT
TRLR-50X	2" BALL CLASS	B78-13LRC	13"X4.50"	3,500 lbs. 2-3/8"	5 LUG	4 LEAF	4 POLE RUBBER FLAT
TRLR-50XF	2" BALL CLASS	B78-13LRC	13"X4.50"	3,500 lbs. 2-3/8"	5 LUG	4 LEAF	4 POLE RUBBER FLAT
TRLR-70W	2" BALL CLASS 3" ADJUSTABLE	205-14C BIAS (4)	14"X5"	3,500 lbs. 3"	5 LUG	5 LEAF	4 POLE RUBBER FLAT
TRLR-70X	2" BALL CLASS 3" ADJUSTABLE	205-14C BIAS (4)	14"X5"	3,500 lbs. 3"	5 LUG	5 LEAF	4 POLE RUBBER FLAT
TRLR-70XF	2" BALL CLASS 3" ADJUSTABLE	205-14C BIAS (4)	14"X5"	3,500 lbs. 3"	5 LUG	5 LEAF	4 POLE RUBBER FLAT
TRLR-100XF	ADJUSTABLE 2-5/6 OPT 3" EYE	205-15C BIAS (4)	14"X5.5"	3,500 lbs. 3"	5 LUG	5 LEAF	4 WIRE LOOM
TRLR-85/125	ADJUSTABLE 2-5/6 OPT 3" EYE	ST225/75R15D RADIAL (4)	14"x6"	(2)-6,000 lbs.	6 LUG	7 LEAF	4 WIRE LOOM
TRLR-150XF	3" BALL EYE	750-16 E BIAS (4)	16"X7"	(2)-6,000 lbs.	8 LUG	7 LEAF	4 WIRE LOOM
TRLR-220XF	3" EYE ADJUSTABLE	ST235/85R16E RADIAL(4)	16"X7"	(2)-7,000 lbs.	8 LUG	Q FLEX	4 WIRE LOOM
TRLR-300XF	3" EYE ADJUSTABLE	ST235/85R16E RADIAL(6)	16"X7"	(2)-6,000 lbs.	8 LUG	Q FLEX	4 WIRE LOOM
TRLR-400XF	3" EYE ADJUSTABLE	ST235/85R16E RADIAL(6)	16"X7"	(3)-7,000 lbs.	8 LUG	Q FLEX	4 WIRE LOOM
TRLR-600XF	5TH WHEEL	ST215/75R17.5H RADIAL (8)	16"X7"	(3)-10,000 lbs.	8 LUG	7 LEAF	6 WIRE LOOM
TRLR-800AR	5TH WHEEL	ST215/75R17.5H RADIAL (8)	16"X7"	(3)-10,000 lbs.	8 LUG	AIR-RIDE	6 WIRE LOOM

# DCA-300SSK SERIES — OPERATION AND SAFETY DECALS

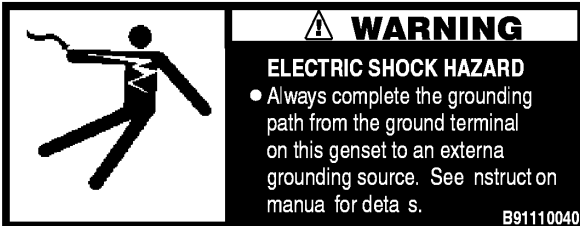
The DCA -300SSK generator is equipped with a number of safety decals. These decals are provided for operator safety and maintenance information. The illustration below and on the preceding pages show the decals as they appear on the machine. Should any of these decals become unreadable, replacements can be obtained from your dealer.



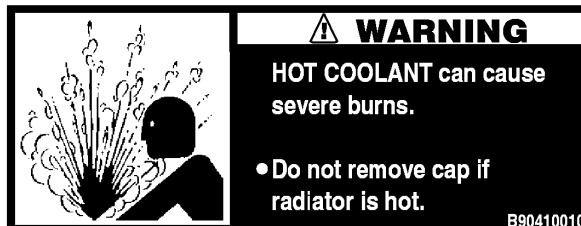
P/N 63606 20204



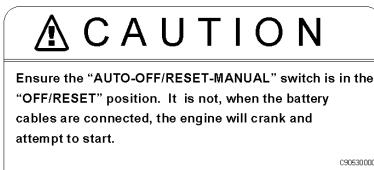
P/N C0551000704



P/N B9511100404



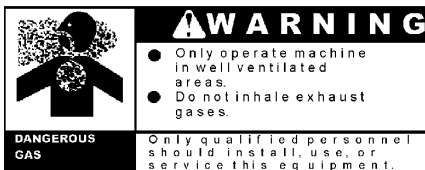
P/N B9504100104



P/N C9505300004



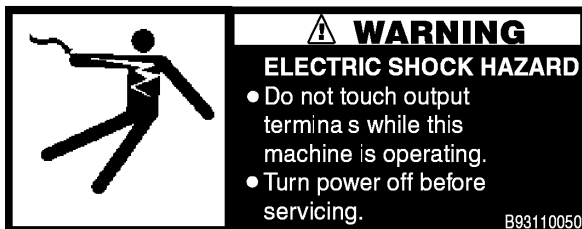
P/N 08040619904



P/N B950420004



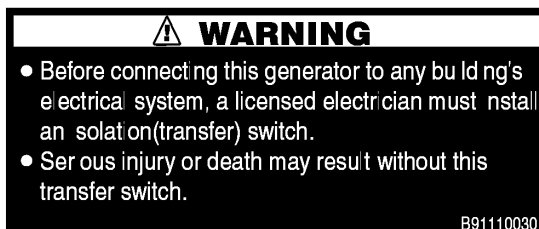
P/N 6360620004



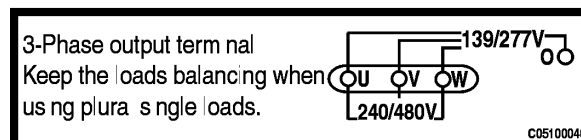
P/N B9531100504



P/N B1552000103



P/N B9511100304



P/N C0551000404

# DCA-300SSK SERIES — OPERATION AND SAFETY DECALS

## HANDLING PROCEDURES

### 1. CHECK TO OPERATING

Pror to operating the engine be sure to check the following items to prevent trouble and accidents:

- (1) Check lubricating oil, cooling water and diesel fuel.
- (2) Check the tension of the fan belt and charging generator driving belt.
- (3) Check the CIRCUIT BREAKER is turned "OFF".
- (4) Set the voltage change-over board to the rated voltage (only Dual voltage type).

### 2. STARTING AND OPERATING

- (1) Turn the battery switch to "ON" position.
- (2) Turn the STARTER SWITCH to "PREHEAT" position for 10 ~ 30 seconds.

Press the STARTER SWITCH to "START" POSITION to start the engine.

- (3) When the engine starts, release the STARTER SWITCH.
- (4) Warm-up the engine for about 5 minutes.
- (5) Rotate the THROTTLE HANDLE to "HIGH SPEED" and adjust the engine speed according to the following table.

No-load operating speed	
50 Hz operation	Approx. 52.5 Hz (1575 rpm)
60 Hz operation	Approx. 62.5 Hz (1875 rpm)

C15200040

P/N C1552000403

## SAFETY INSTRUCTIONS

Improper operation of this machine can cause severe injury or death.

- Read the instruction manual carefully before operating or servicing.

This machine should only be operated by a person with sufficient knowledge and skill to ensure safe operation.

High voltage circuits are located inside the output terminal cover and control panel.

- Close the cover and control panel before operating.

Moving parts and hot surfaces are contained within the enclosure.

- Close all doors and lock them before operating.

C25100000

P/N C255100004



### WARNING

**HOT PARTS** can burn skin.

- Do not touch until the machine has sufficiently cooled.

B90400030

P/N B9504000304



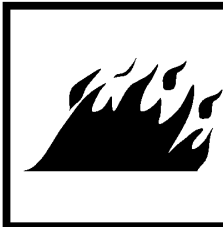
### WARNING

**ELECTRIC SHOCK HAZARD**

- Do not touch internal wiring or connections while this machine is operating.
- Turn power off before servicing.

B93110060

P/N B9531100604



### WARNING

**DIESEL FUEL** can cause fire or explosion.

- Stop engine before fueling.
- Keep cigarettes, sparks and flame away.

B90450000

P/N B9504500004

**CIRCUIT  
BREAKER**

S-3031

P/N 08406 24504

**PILOT LAMP**

S-3033

P/N 0840624704

## WHISPERWATT 300



**MQ POWER CORP.**

**WHISPERWATT 300**

**300 KVA AC GENERATOR  
MODEL DCA-300SSK**

C26110190

P/N C2561101903

**WATER • OIL CHECK AND FILL DAILY**

C05100040

P/N C0551000404

**DIESEL FUEL**

S-1756

P/N 1320620904

**SUPPORT HOOK**

Never use it for lifting the unit.  
Use the LIFT HOOK on the roof for lifting.

S-2257

P/N 13206 21504



P/N 0840625902

# DCA-300SSK SERIES — GENERAL INFORMATION

## DCA-300SSK FAMILIARIZATION

### Generator

The MQ Power DCA-300SSK series generators are **240 kW generators** that are designed as a high quality portable (requires a trailer for transport) power source for telecom sites, lighting facilities, power tools, submersible pumps and other industrial and construction machinery.

### Engine Control Panel

The “**Engine Control Panel**” is provided with the following:

- Tachometer
- Throttle Handle (Up to S/N 3701673)
- Water Temperature Gauge
- Oil Pressure Gauge
- Charging Ammeter Gauge
- Engine Warning Display Module
- Engine Speed Switch (S/N 3701674~)
- Pre-Heat Button
- Pre-Heat Lamp
- Emergency Stop Button
- Battery Switch
- Auto On/Off Engine Controller (S/N 3701674~)
- Ignition Switch (Up to S/N 3701673)

### Generator Control Panel

The “**Generator Control Panel**” is provided with the following:

- Output Voltage Adjustment Knob
- Frequency Meter (Hz)
- AC Ammeter (Amps)
- AC Voltmeter (Volts)
- Ammeter Change-Over Switch
- Voltmeter Change-Over Switch
- Panel Light
- Panel Light Switch
- Pilot Lamp

### Output Terminal Panel

The “**Output Terminal Panel**” is provided with the following:

- 3 auxiliary 240/139V output receptacles, 50 amp
- 3 auxiliary circuit breakers 240V @50 amps
- 2 120V GFCI receptacles, 20 amp
- 2 GFCI circuit breakers 120V@ 20amps

### Control Box

The “**Control Box**” is provided with the following:

- Main Circuit Breaker 800 amps
- Over-Current Relay

### Open Delta Excitation System

The DCA-300SSK series generators are equipped with the state of the art “**Open-Delta**” excitation system. The open delta system consist of an electrically independent winding wound among stationary windings of the AC output section.

There are four leads: A, B, C and D. During light loads, the power to the **Automatic Voltage Regulator (AVR)** is supplied from the leads parallel connections of B&C. When loads increase, the AVR switches and accepts power from leads A&D. The output of leads A&D increase proportionally with load. This of adding the voltages to each phase provides better voltage response during heavy loads.

The connections of the AVR to the AC output windings are for sensing only. No power is required from these windings.

The open-delta design provides virtually unlimited excitation current, offering maximum motor starting capabilities. The excitation does not have a “**fixed ceiling**” and responds according the demands of the required load.

### Engine

The **DCA-300SSK** is powered by a 4 cycle, water cooled, turbocharged KOMATSU Model SA6D125E-2 **diesel** engine. The **DCA-300SSKII** is powered by a 4 cycle, water cooled, air to air after cooled, turbocharged KOMATSU Model SAA6D125E-2 **diesel** engine. These engines are designed to meet every performance requirement for the generator. Reference Table 2 for engine specifications.

In keeping with Multiquip's policy of constantly improving its products, the specifications quoted herein are subject to change without prior notice.

The basic controls and indicators for the DCA-300SSK series generators are addressed on the following pages.

### Electronic Governor System

The DCA300SSK II is equipped with an electronic governor system. It is made up of two parts; an electronic controller that monitors frequency variation as the load increases and decreases, and an electronic actuator that controls the engine throttle. Thr frequency is regulated at  $\pm 0.25$  to help protect sensitive equipment.

### Microprocessor Engine Control (MPEC)

The DCA300SSK III incorporates the use of a **microprocessor engine controller** unit (MPEC), which monitors basic engine functions and also allows the generator to operate in an unattended mode.

# DCA-300SSK SERIES — MAJOR COMPONENTS

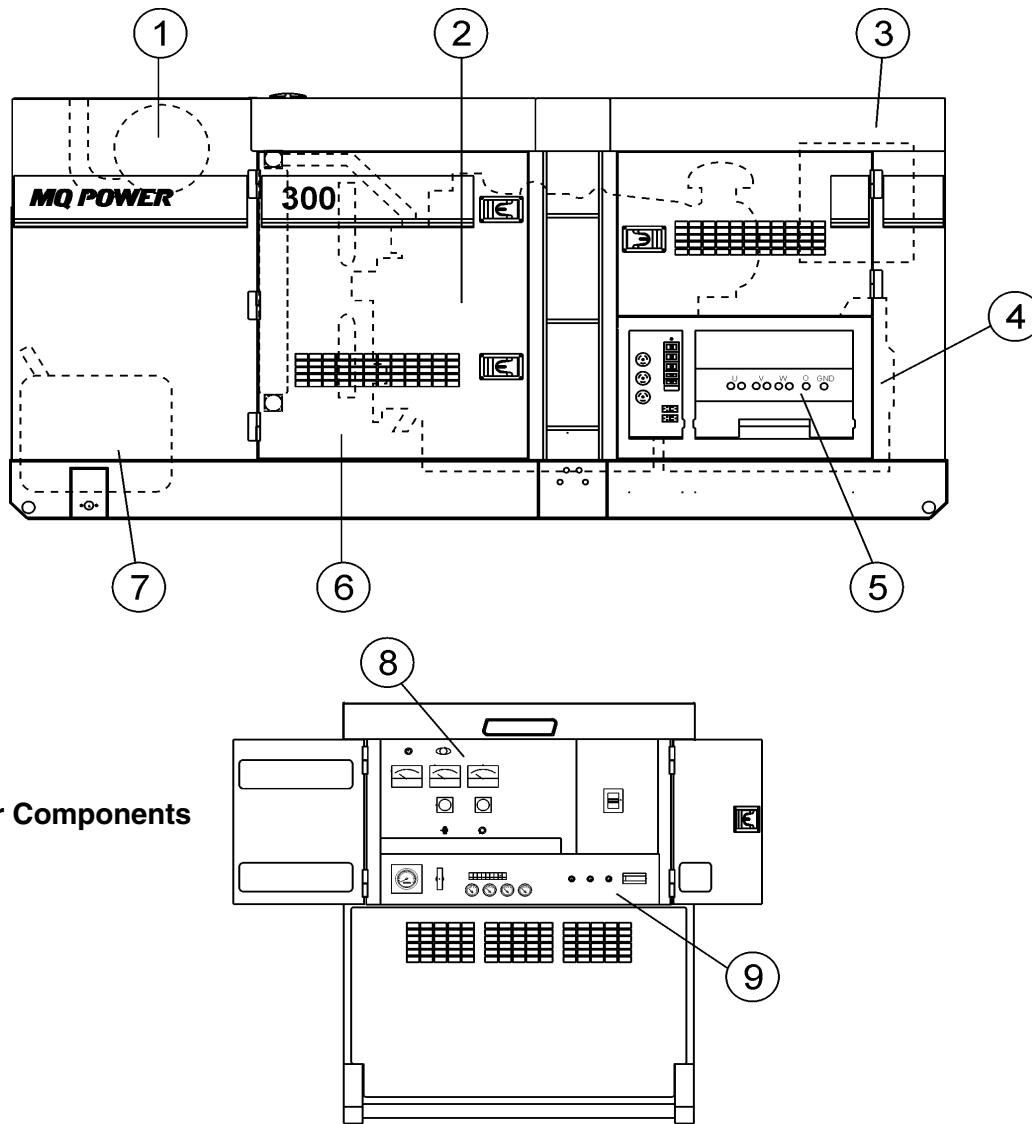


Figure 5. Major Components

Table 4. Generator Major Components	
ITEM NO.	DESCRIPTION
1	Muffler Assembly
2	Engine Assembly
3	Enclosure Assembly
4	Generator Assembly
5	Output Terminal Assembly
6	Fuel Tank Assembly
7	Battery Assembly
8	Generator Control Panel Assembly
9	Engine Operating Panel Assembly

# DCA-300SSK — GENERATOR CONTROL PANEL

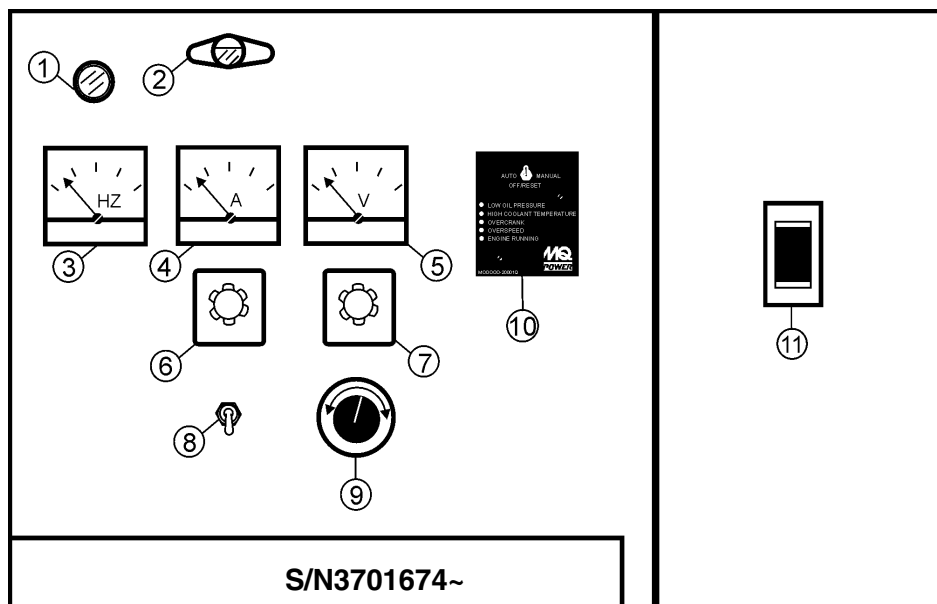
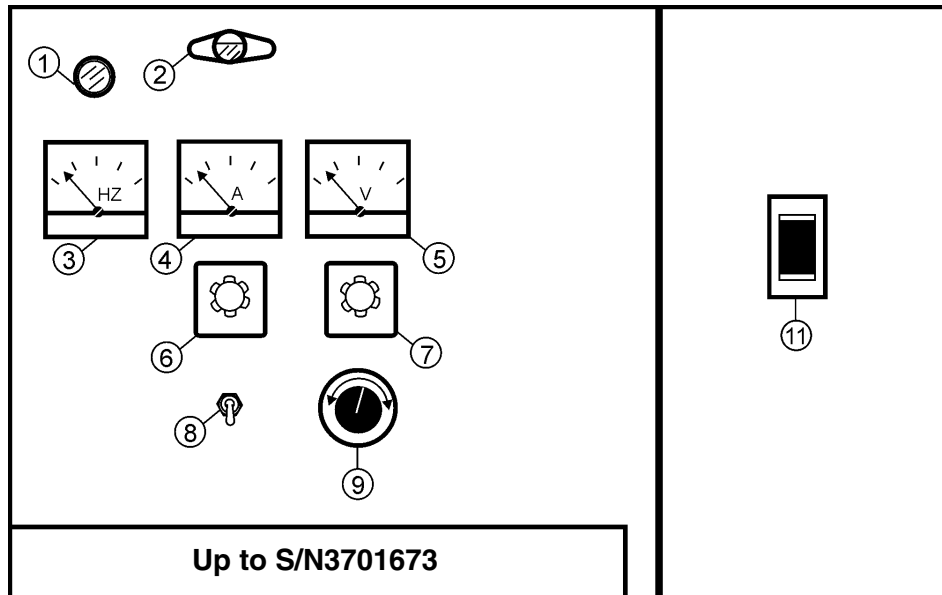


Figure 6. Generator Control Panel

# DCA-300SSK — GENERATOR CONTROL PANEL

The definitions below describe the controls and functions of the DCA-300SSK “**Control Panel**” (Figure 8).

1. **Pilot Lamp** – Indicates that the generator is working properly.
2. **Panel Light** – Normally used in dark areas or at night time. When activated, panel lights will illuminate. When the generator is not in use be sure to turn the panel light switch to the **OFF** position.
3. **Frequency Meter** – Indicates the output frequency in hertz (Hz). Normally 60 Hz  $\pm$ 1 Hz .
4. **AC Ammeter** – Indicates the amount of current the load is drawing from the generator.
5. **AC Voltmeter** – Indicates the single phase output voltage present at the UVWO terminals.
6. **Ammeter Change-Over Switch** – This switch allows the AC ammeter to indicate the current flowing to the load connected to any phase of the output terminals, or to be switched off.
7. **Voltmeter Change-Over Switch** – This switch allows the AC voltmeter to indicate phase to phase voltage between any two phases of the output terminals or to be switched off.
8. **Panel Light Switch** – When activated will turn on control panel light.
9. **Voltage Regulator Control** – Allows manual adjustment of the generator’s output voltage.
10. **Microprocessor Engine Controller (MPEC S/N3701674~)**  
This controller has a vertical row of status LED’s (inset), that when lit, indicate that an engine malfunction (fault), has been detected. When a fault has been detected the engine controller will evaluate the fault. Any **major** fault will cause the controller to shutdown the generator.



During **cranking cycle**, The MPEC will attempt to crank the engine for 10 seconds before disengaging. If the engine does not engage (start) by the third attempt, the engine will be shutdown by the engine controller’s “ Over Crank Protection” mode. If the engine engages at a speed (RPM's) that is not safe, the controller will shutdown the engine by initializing the “**Over Speed Protection**” mode.

Also the engine controller will shutdown the generator in the event of low oil pressure, high coolant temperature, low coolant level, and loss of magnetic pickup. These conditions can be observed by monitoring the **LED** status indicators on the front of the controller module.

- A. **Off/Manual/Auto Switch** – This switch controls the running of the generator. If this switch is left in the “**OFF**” position, the generator will not run. When this switch is set to the **manual** position, the generator will start immediately. If the generator is to be connected to a building's AC power source via a transfer switch (isolation), place the switch in the **auto** position. In this position the generator will monitor the AC line output from the building's power source.
  - B. **Low Oil Pressure** – Indicates the engine pressure has fallen below 15 psi. The oil pressure is detected using variable resistive values from the oil pressure sending unit. This is considered a **major** fault.
  - C. **High Coolant Temperature** – Indicates the engine temperature has exceeded 215°F. The engine temperature is detected using variable resistive values from the temperature sending unit. This is considered a **major** fault.
  - D. **Overcrank Shutdown** – Indicates the unit has attempted to start a pre- programmed number of times, and has failed to start. The number of cycles and duration are programmable. Typical programmable start settings is 3 cycles with a 10 second duration . This is considered a **major** fault.
  - E. **Overspeed Shutdown** – Indicates the engine is running at an unsafe speed. This is considered a **major** fault.
  - F. **Engine Running** – Indicates that engine is running at a safe operating speed.
11. **Main Circuit Breaker** – This three-pole, 800 amp main breaker is provided to protect the **UVWO** voltage output terminals from overload.

# DCA-300SSK — ENGINE OPERATING PANEL

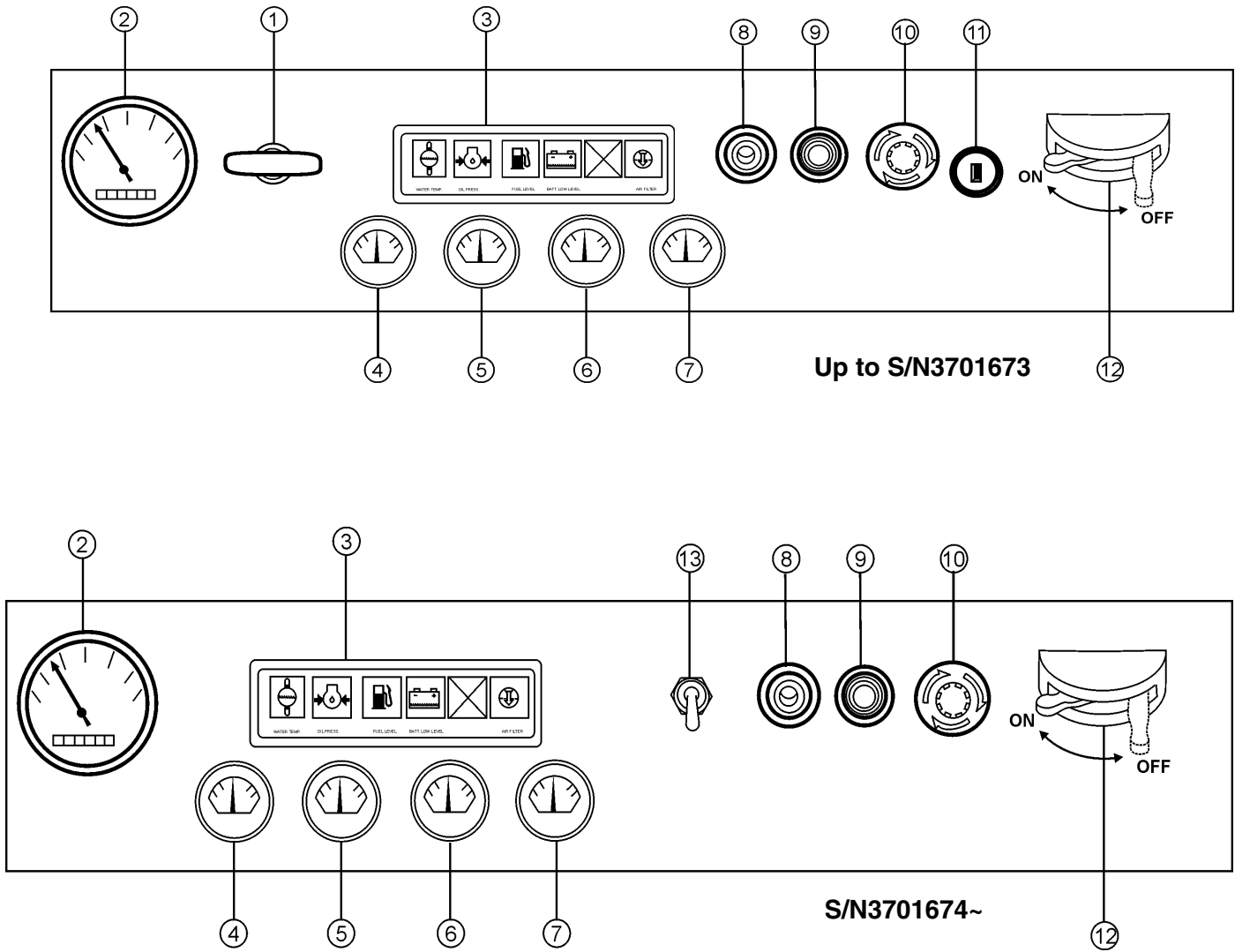
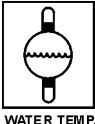




Figure 7. Engine Operating Panels


# DCA-300SSK — ENGINE OPERATING PANEL


The definitions below describe the controls and functions of the DCA-300SSK or DCA-300SSK2 “**Engine Operating Panels**” (Figure 7).

1. **Throttle Handle** - This handle controls the speed of the engine (low or high).
2. **Tachometer** – Indicates engine speed in RPM's for 60 Hz operation. This meter should indicate 1800 RPM's when the rated load is applied. In addition a built in hour meter will record the number of operational hours that the generator has been in use.
3. **Engine Warning Display Module** – This module display's the following engine failures:
  - A. **Overheat Lamp** – This lamp goes **ON** when the cooling water temperature rises abnormally. If the lamp goes **ON** during normal operation of the generator, the emergency shutdown device will stop the engine automatically.

WATER TEMP.
  - B. **Low Oil Pressure Lamp** – During normal operation of the generator this lamp should remain **OFF**. When the **Auto-OFF/Reset-Manual** switch is set to the “**Manual**” position to start the engine, the lamp will be lit. After the oil pressure rises after start-up the lamp will go **OFF**. If this lamp is ever lit (**ON**) during normal operation of the generator, the emergency shutdown device will stop the engine automatically.

OIL PRESS.
  - C. **Low Fuel Level Lamp** – When this lamp is **ON**, it is time to stop the engine and add fuel. Remember to let the engine cool before adding fuel.

FUEL LEVEL
  - D. **Low Battery Fluid Lamp** – This lamp goes **ON** when the battery fluid is low. If this lamp goes **ON** during normal operation of the generator, stop the engine and fill the battery with distilled water to the specified level.

BATT. LOW LEVEL
  - E. **Clogged Air Filter Lamp** – This lamp goes **ON** when the air filter is clogged. If this lamp goes **ON** during normal operation of the generator, stop the engine and replace the air filter.

AIR FILTER

4. **Oil Pressure Gauge** – During normal operation this gauge be should read in the “**GREEN**” zone. When starting the generator the oil pressure mar read a little bit higher, but after the engine warms up the oil pressure should return to the green zone.
5. **Water Temperature Gauge** – During normal operation this gauge be should read in the “**GREEN**” zone.
6. **Charging Ammeter Gauge** – Indicates the current being supplied by the engine's alternator which provides current for generator's control circuits and battery charging system.
7. **Fuel Gauge** - Indicates amount of diesel fuel available.
8. **Pre-Heat Lamp** – Indicates that the glow plugs of the diesel engine are hot and the engine is ready to be started.
9. **Pre-Heat Button** – Press and hold this button until the preheat lamp is lit (**ON**).
10. **Emergency Stop Button** – Push this button inward to stop the engine in the event of an emergency. **DO NOT** use this button as a means of stopping the engine.
11. **Ignition Switch (Up to S/N3701673)** – Four position switch, **pre-heat**, **stop**, **run** and **start**. Insert ignition key to start and stop engine.
12. **Battery Switch** – This switch should be set to the **ON** position during normal operation. When the engine has been stop, place this switch in the **OFF** position. **DO NOT** turn this switch during normal operation, it could cause damage to the electrical equipment.
13. **Engine Speed Switch (S/N3701674-)** – Changes the speed of the engine rpm's (low or high).

# DCA-300SSK — OUTPUT TERMINAL PANEL OVERVIEW

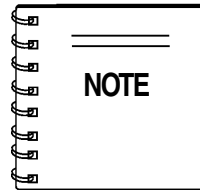
## Output Terminal Familiarization

The “**Output Terminal Panel**” (Figure 8) is provided with the following:

- Three 240/139V output receptacles, 50 amp
- Three circuit breakers 240V @50 amps
- Two 120V GFCI receptacles, 20 amp
- Two (2) GFCI circuit breakers 120V@ 20 amps
- Eight (8) output terminal lugs

## Output Terminal Panel

Shown below (Figure 8) is the **Output Terminal Panel**, lift up on the cover to gain access to receptacles and terminal lugs.



Terminal legs “**O**” and “**Ground**” are considered **bonded grounds**.

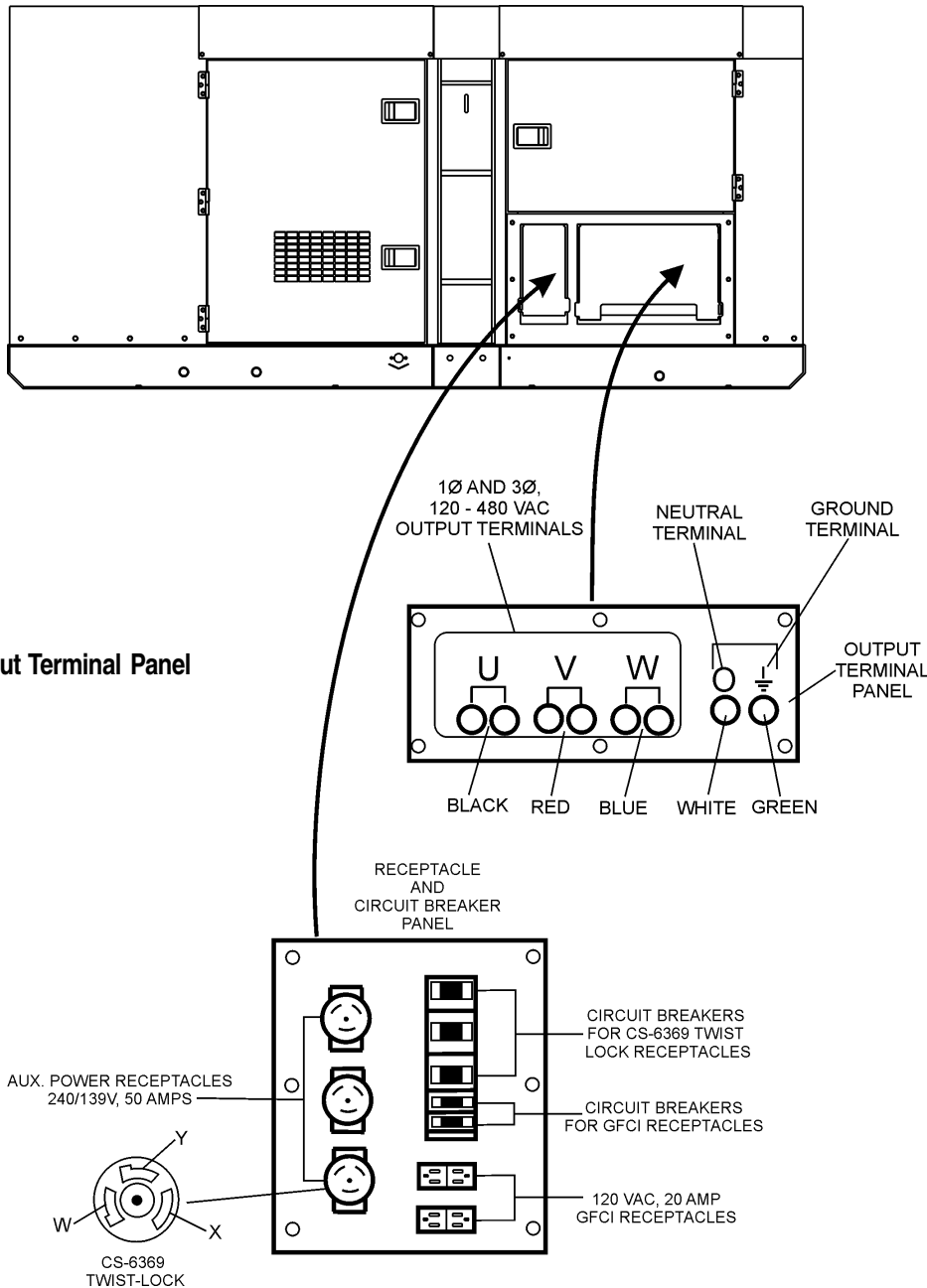


Figure 8. Output Terminal Panel

# DCA-300SSK SERIES — OUTPUT TERMINAL PANEL OVERVIEW

## 120 VAC GFCI Receptacles

There are two 120 VAC, 20 amp GFCI (Duplex Nema 5-20R) receptacles provided on the output terminal panel. These receptacles can be accessed in **any voltage change-over board** position. Each receptacle is protected by a 20 amp circuit breaker. These breakers are located directly above the GFCI receptacles. Remember the load output (current) of both GFCI receptacles is dependent on the load requirements of the UVWO terminals.

Pressing the **reset** button resets the GFCI receptacle after being tripped. Pressing the "**Test Button**" (See Figure 9) in the center of the receptacle will check the GFCI function. Both receptacles should be tested at least once a month.

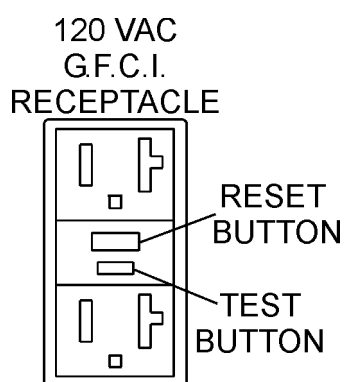


Figure 9. G.F.C.I. Receptacle

## Twist Lock Dual Voltage 240/139 VAC Receptacles

There are three 240/139 VAC, 50 amp auxiliary twist-lock (CS-6369) receptacles (Figure 10) provided on the output terminal panel. These receptacles can be accessed in **any voltage change-over board** position.

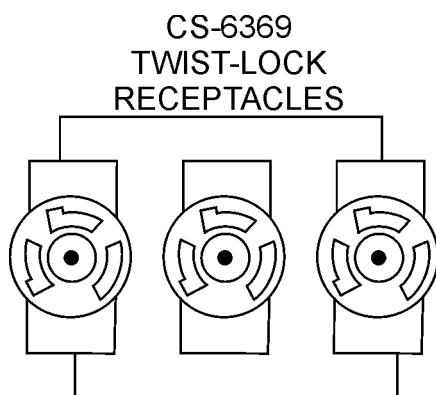


Figure 10. 240/139 VAC Twist-Lock Auxiliary Receptacles

Each auxiliary receptacle is protected by a 50 amp circuit breaker. These breakers are located directly above the GFCI receptacles. Remember the load output (current) on all three receptacles is dependent on the load requirements of the UVWO terminals.

Turn the **voltage regulator control knob** (Figure 11) on the control panel to obtain the desired voltage. Turning the knob clockwise will **increase** the voltage, turning the knob counter-clockwise will **decrease** the voltage.



Figure 11. Voltage Regulator Control Knob

## Removing the Plastic Face Plate (UVWO Terminals)

The UVWO terminal lugs are protected by a plastic face plate cover (Figure 12). Un-lock the locking latch, and lift the terminal cover to gain access to the plastic face plate. Remove the screws securing the face plate to the terminal enclosure, then lift the plastic hinged face plate.

After the load wires have been securely attached to the UVWO terminals, reinstall the plastic face plate. Place the terminal cover in the down position and secure the locking latch.

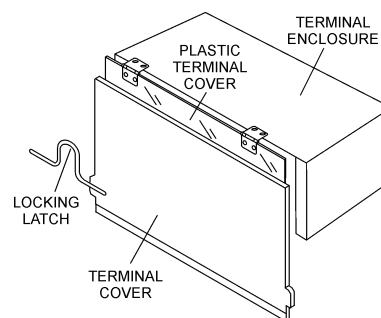


Figure 12. Plastic Face Plate (UVWO Terminals)

# DCA-300SSK SERIES — OUTPUT TERMINAL PANEL FAMILIARIZATION

## Connecting Loads

Loads can be connected to the generator by the **UVWO** terminal lugs or the convenience receptacles. (See Figure 13). Make sure to read the operation manual before attempting to connect a load to the generator.

To protect the UVWO output terminals from overload, a 3-pole, 800 amp, **main** circuit breaker is provided. Make sure to switch **ALL** circuit breakers to the "OFF" position prior to starting the engine.

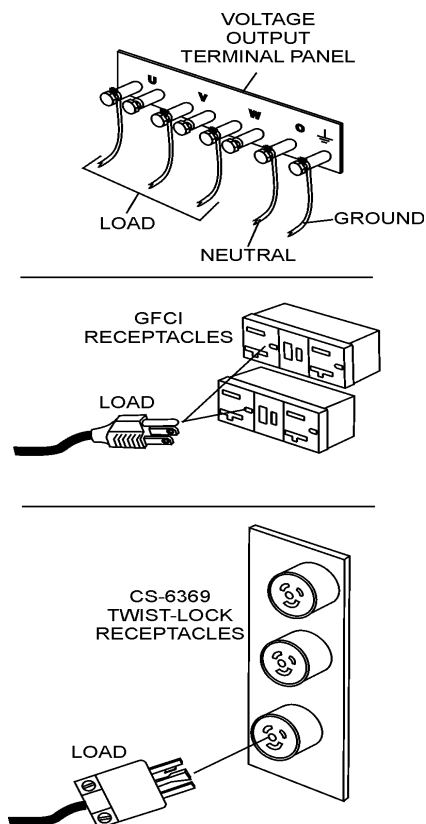


Figure 13. Connecting Loads

## Over Current Relay

An **over current relay** (Figure 14) is connected to the main circuit breaker. In the event of an overload, both the circuit breaker and the over current relay may trip. If the circuit breaker can not be reset, the **reset button** on the over current relay must be pressed. The over current relay is located in the control box.

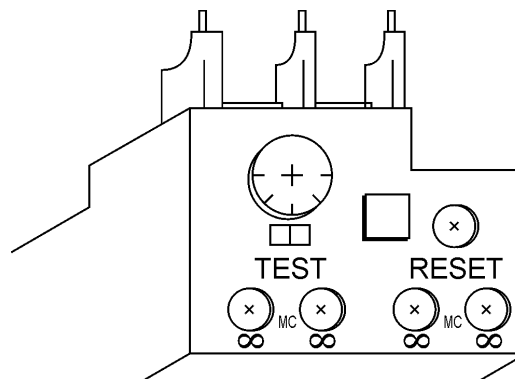


Figure 14. Over Current Relay

## Maximum Power Output (KW)

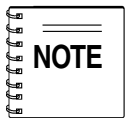
The entire load connected to the UVWO output terminal lugs, duplex and auxiliary receptacles must not exceed 264 kw in standby or 240 kw in prime output.

# DCA-300SSK SERIES — LOAD APPLICATION

## Single Phase Load

Always be sure to check the nameplate on the generator and equipment to insure the wattage, amperage and frequency requirements are satisfactorily supplied by the generator for operating the equipment.

Generally, the wattage listed on the nameplate of the equipment is its rated output. Equipment may require 130—150% more wattage than the rating on the nameplate, as the wattage is influenced by the efficiency, power factor and starting system of the equipment.



If wattage is not given on the equipment's name plate, approximate wattage may be determined by multiplying nameplate voltage by the nameplate amperage.

WATTS = VOLTAGE x AMPERAGE

The power factor of this generator is 0.8. See Table 5 below when connecting loads.

**Table 5. Power Factor By Load**

Type Of Load	Power Factor
Single-phase induction motors	0.4 - 0.75
Electric heaters, incandescent lamps	1.0
Fluorescent lamps, mercury lamps	0.4 - 0.9
Electronic devices, communication equipment	1.0
Common power tools	0.8

**Table 6. Cable Selection (60 Hz, Single Phase Operation)**

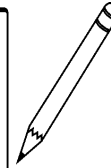
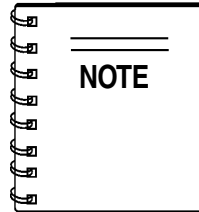
Current in Amperes	Load In Watts		Maximum Allowable Cable Length			
	At 120 Volts	At 240 Volts	#10 Wire	#12 Wire	#14 Wire	#16 Wire
2.5	300	600	1000 ft.	600 ft.	375 ft.	250 ft.
5	600	1200	500 ft.	300 ft.	200 ft.	125 ft.
7.5	900	1800	350 ft.	200 ft.	125 ft.	100 ft.
10	1200	2400	250 ft.	150 ft.	100 ft.	
15	1800	3600	150 ft.	100 ft.	65 ft.	
20	2400	4800	125 ft.	75 ft.	50 ft.	

**CAUTION:** Equipment damage can result from low voltage.

## Three Phase Load

When calculating the power requirements for 3-phase power use the following equation:

$$KVA = \frac{VOLTAGE \times AMPERAGE \times 1.732}{1000}$$



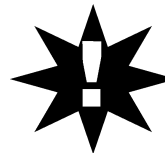
Motors and motor-driven equipment draw much greater current for starting than during operation.

An inadequate size connecting cable which cannot carry the required load can cause a voltage drop which can burn out the appliance or tool and overheat the cable. See Table 5.

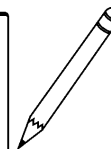
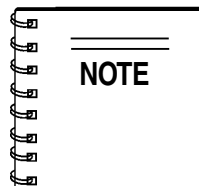
- When connecting a resistance load such as an incandescent lamp or electric heater, a capacity of up to the generating set's rated output (kW) can be used.
- When connecting a fluorescent or mercury lamp, a capacity of up to the generating set's rated output (kW) multiplied by 0.6 can be used.
- When connecting an electric drill or other power tools, pay close attention to the required starting current capacity.

When connecting ordinary power tools, a capacity of up to the generating set's rated output (kW) multiplied by 0.8 can be used.

## CAUTION:



Before connecting this generator to any building's electrical system, a **licensed electrician** must install an **isolation (transfer) switch**. Serious injury or death may result without the installation of a transfer switch.



If 3Ø load (kVA) is not given on the equipment nameplate, approximate 3Ø load output maybe determined by multiplying voltage by amperage by 1.732.

# DCA-300SSK SERIES — GENERATOR OUTPUTS

## Generator Output Voltages

A wide range of voltages are available to supply voltage for many different applications. Voltages are selected by applying jumpers (6) to the **voltage change-over board** (Figure 15). To obtain some of the voltages as listed in Table 7 (see below) will require a fine adjustment using the **voltage regulator (VR) control knob** located on the control panel.

## Voltage Change-Over Board

The **voltage change-over board** (Figure 15) is located on the control box, behind the generator control panel. This board has been provided for ease of voltage selection.

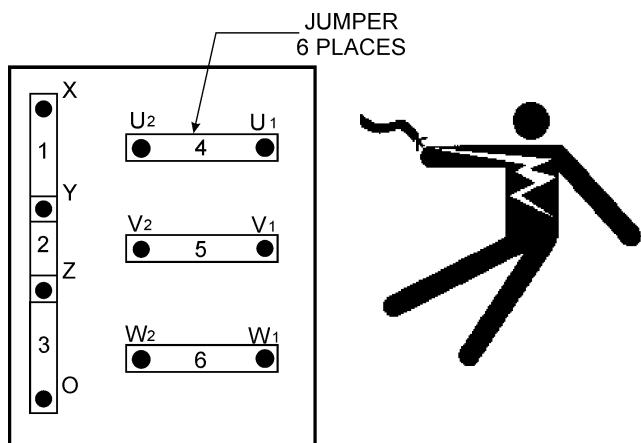


Figure 15. Voltage Change-Over Board  
240V Configuration

## DANGER:



**NEVER** attempt to place jumper plates on the **voltage change-over board** while the generator is in operation. There exist the possibility of **electrocution, electrical shock or burn, which can cause severe bodily harm or even death!**

Table 7. Generator Available Voltages

	208V	220V	240V	416V	440V	480V
Three-Phase						
Single-Phase	120V	127V	139V	240V	254V	277V

## Generator Amperage

Tables 8 and 9 describe the generator's current output capability for both 1Ø-phase and 3Ø phase applications.

Table 8. Generator Ampere Ratings — 1Ø

kW	139V	240V	277V	480V
20	144	83	72	42
40	288	167	144	83
60	432	250	217	125
80	576	333	289	167
100	719	417	361	208
120	863	500	433	250
140	1007	583	505	292
160	1151	667	578	333
180	1295	750	650	375
200	1439	833	722	417
220	1583	917	794	458
240 (Max)	1727	1000	866	500

Table 9. Generator Ampere Ratings — 3Ø

KW	240V	480V
20	60	30
40	120	60
60	180	90
80	241	120
100	301	150
120	361	180
140	421	210
160	481	241
180	541	271
200	601	301
220	662	331
240	722	361

# DCA-300SSK SERIES — GENERATOR OUTPUTS/GAUGE READING

## Maximum Amps

Table 10 shows the *maximum* amps the generator can provide. **DO NOT** exceed the maximum amps as listed.

Table 10. Generator Maximum Amps	
Model:	DCA300SSK Series
Rated Voltage	Maximum Amps
Single Phase 120 Volt	2000 amps (4 wire)
Single Phase 240 Volt	1000 amps (4 wire)
Three Phase 240 Volt	720 amps
Three Phase 480 Volt	360 amps

## How to Read the Output Terminal Gauge.

The AC ammeter and AC voltmeter change-over switches on the control panel **DO NOT** effect the generator output. They are provided to help observe how much power is being supplied, produced at the UVWO terminals lugs.

When the voltage change-over board is jumpered for 3Ø, 240V operation (See Figure 16), place the **AC Voltmeter Change-Over Switch** (Figure 17) to the W-U position and the **AC Ammeter Change-Over Switch** (Figure 19) to the U or W position to read the output on the selected leg.

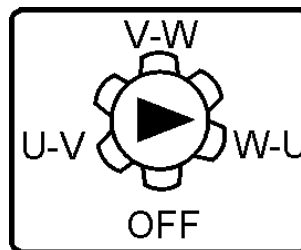


Figure 17. AC Voltmeter Change-Over Switch

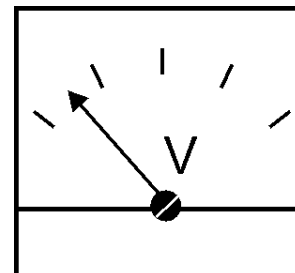


Figure 18 AC Voltmeter Gauge (Volt reading on W-U Lug)

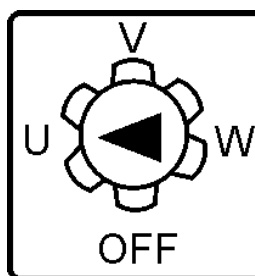


Figure 19. AC Ammeter Change-Over Switch

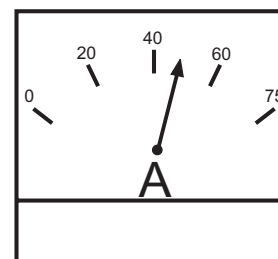


Figure 20. AC Ammeter (Amp reading on U lug)

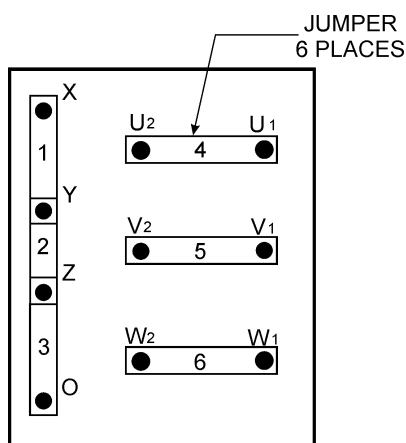
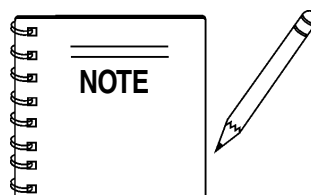


Figure 16. Voltage Change-Over Board 240V Configuration



The *ammeter* and *voltmeter* gauges are only active when the UVWO terminals are in use.

# DCA-300SSK SERIES — OUTPUT TERMINAL PANEL CONNECTIONS

## UVWO Terminal Output Voltages

Various output voltages can be obtained using the UVWO output terminal lugs. The voltages at the terminals are dependent on the placement of the jumpers plates (6) on the **Voltage Change-Over Board** and the adjustment of the **Voltage Regulator Control Knob**.

Remember the voltage change-over board determines the **range** of the output voltage and can be configured in two different positions that provide 6 different output voltages at the UVWO output terminals. The generator is shipped from the factory in the 240V configuration. The voltage regulator (VR) allows the user to increase or decrease the selected voltage.

## 3Ø-240V UVWO Terminal Output Voltages

1. Jumper the voltage change-over board for 240V operation as shown in Figure 21.

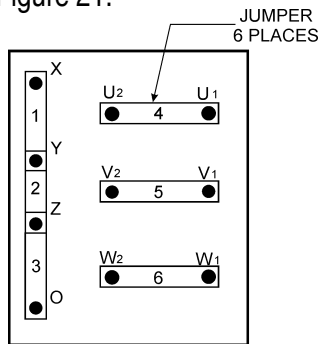


Figure 21. Voltage Change-Over Board 240V Configuration

2. Connect the load wires to the UVWO terminals as shown in Figure 22.

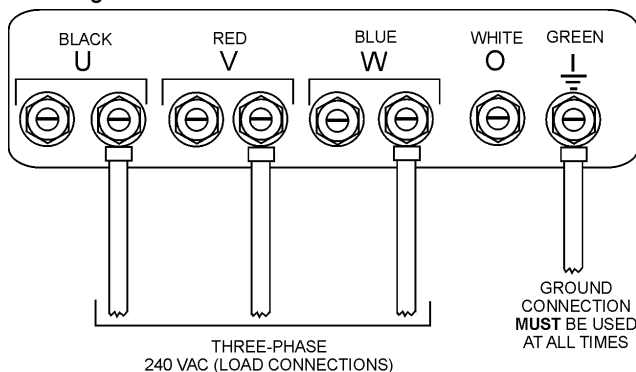


Figure 22. UVWO Terminal Lugs 3Ø-240V Connections

3. Turn the voltage regulator knob (Figure 23) clockwise to increase voltage output, turn counterclockwise to decrease voltage output. Use voltage regulator adjustment knob whenever fine tuning of the output voltage is required



Figure 23. Voltage Regulator Knob

## 1Ø-240V UVWO Terminal Output Voltages

1. Make sure the voltage change-over board is jumpered for 240V operation as shown in Figure 21 .
2. Connect the load wires to the UVWO terminals as shown in Figure 24.

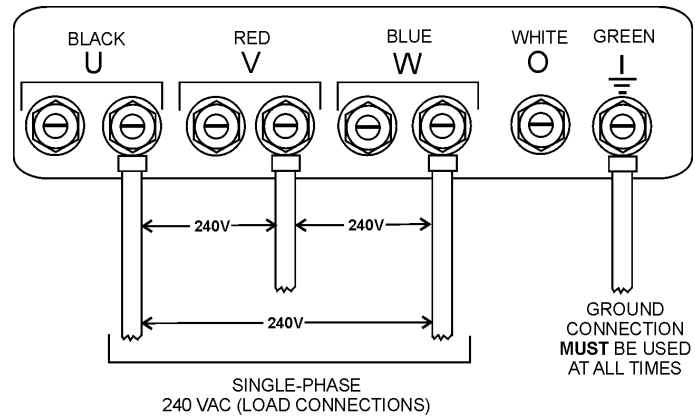


Figure 24. UVWO Terminal Lugs 1Ø-240V Connections

## 1Ø-139V UVWO Terminal Output Voltages

1. Make sure the voltage change-over board is jumpered for 240V operation as shown in Figure 21.
2. Connect the load wires to the UVWO terminals as shown in Figure 25.

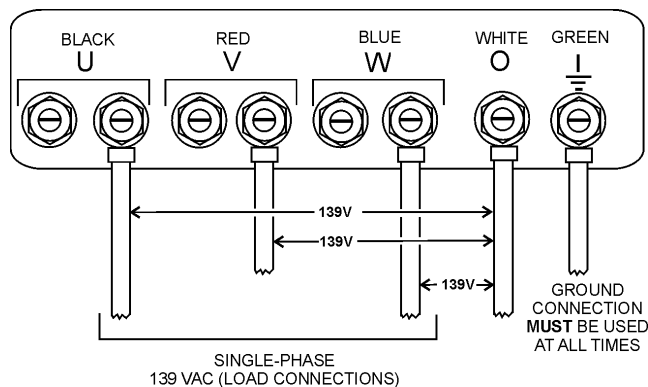
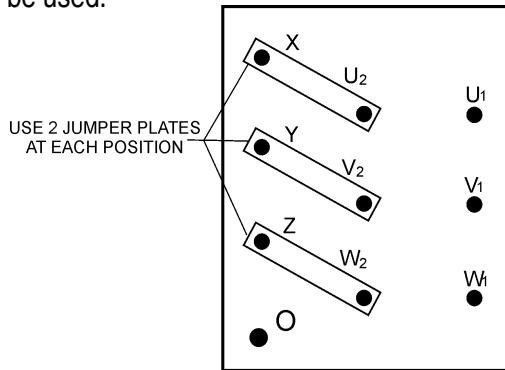


Figure 25. UVWO Terminal Lugs 1Ø-139V Connections

# DCA-300SSK SERIES — OUTPUT TERMINAL PANEL CONNECTIONS

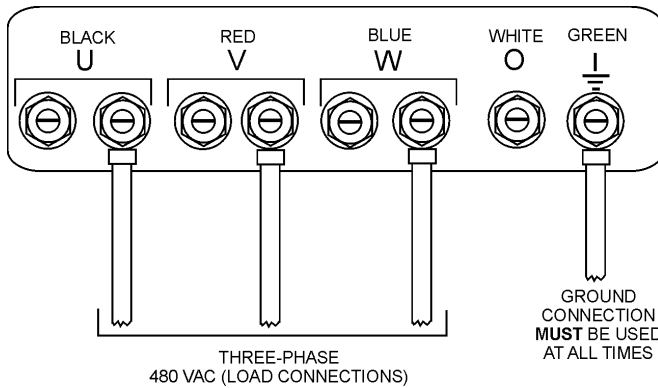
## 3Ø-480V UVWU Terminal Output Voltages

1. Jumper the voltage change-over board for 480V operation as shown in Figure 26. This configuration uses 6 jumper plates in 3 different positions. Remember there are 2 jumper plates at every position. Every jumper plate **must** be used.

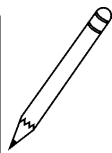
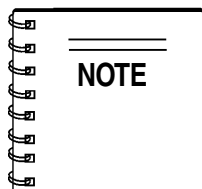


**Figure 26. Voltage Change-Over Board 480V Configuration**

2. Connect the load wires to the UVWU terminals as shown in Figure 27.



**Figure 27. UVWU Terminal Lugs 3Ø-480V Connections**



**ALWAYS** make sure that the connections to the UVWU terminals are **secure** and **tight**. The possibility of arcing exists, that could cause a fire.

## DANGER:

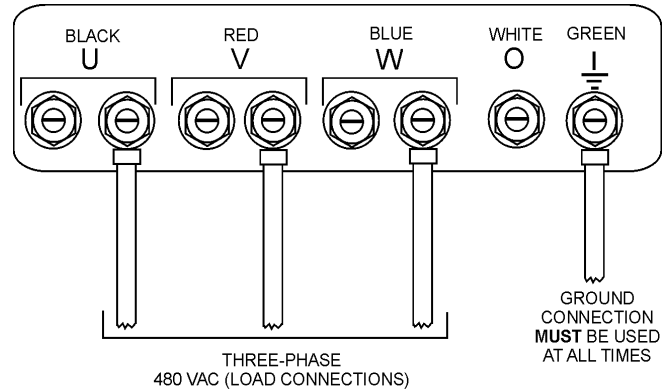


**NEVER** attempt to connect a load to the **UVWU** output terminals while the generator is operating. The possibility exists of serious injury, electrical shock, electrocution even death.



## 1Ø-480V UVWU Terminal Output Voltages

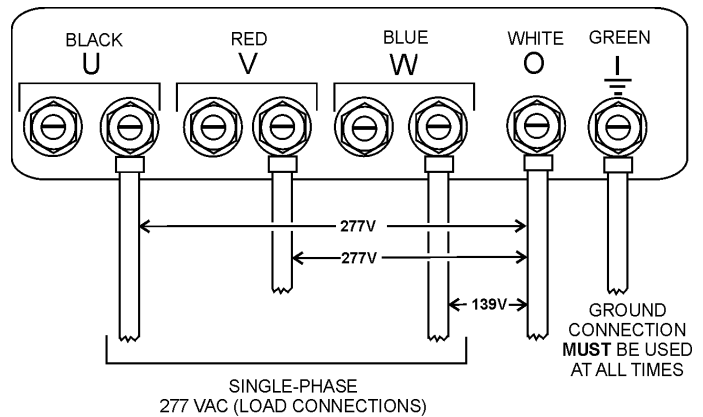
1. Make sure the voltage change-over board is jumpered for 480V operation as shown in Figure 26.
2. Connect the load wires to the UVWU terminals as shown in Figure 28.



**Figure 28. UVWU Terminal Lugs 1Ø-480V Connections**

## 1Ø-277V UVWU Terminal Output Voltages

1. Make sure the voltage change-over board is jumpered for 480V operation as shown in Figure 26.
2. Connect the load wires to the UVWU terminals as shown in Figure 29.



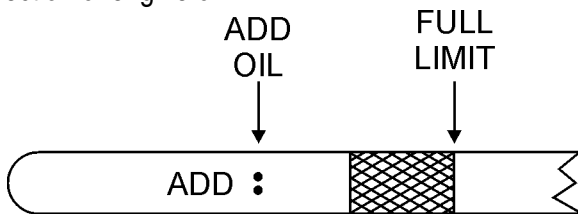
**Figure 29. UVWU Terminal Lugs 1Ø-277V Connections**

## Circuit Breakers

To protect the generator from an overload, a 3-pole, 800 amp, **main** circuit breaker is provided to protect the UVWO output terminals from overload. In addition two single-pole, 20 amp **GFCI** circuit breakers are provided to protect the GFCI receptacles from overload. Three 50 amp **load** circuit breakers have also been provided to protect the auxiliary receptacles from overload. **Make sure to switch ALL circuit breakers to the "OFF" position prior to starting the engine.**

## Lubrication Oil

Fill the engine crankcase with lubricating oil through the filler hole, but **DO NOT** overfill. Make sure the generator is level. Also verify that the oil level is maintained between the two notches (Figure 30) on the dipstick. See Table 11 for proper selection of engine oil.



**Figure 30. Engine Oil Dipstick**

When checking the engine oil, be sure to check if the oil is clean. If the oil is not clean, drain the oil by removing the oil drain plug, and refill with the specified amount of oil as outlined in the **Komatsu Engine Owner's Manual**. Oil should be warm before draining.

Other types of motor oils may be substituted if they meet the following requirements:

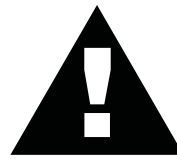
- API Service Classification CH-4
- API Service Classification CG-4
- API Service Classification CF-4
- ACEA Specification E3
- ACEA Specification E2

**Table 11. Recommended Motor Oil**

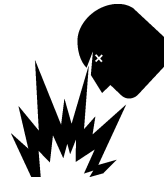
Temperature Range	Type Oil
77°F and greater (25°C and greater)	SAE15W-40 or SAE40
32°F to 77°F (0°C to 25°C)	SAE 10W-30 or SAE30
-22°F to -32°F (-30°C to 0°C)	SAE10W-30 or SAE10

## Fuel Check

### DANGER:



Fuel spillage on a **hot!** engine can cause a **fire** or **explosion**. If fuel spillage occurs, wipe up the spilled fuel completely to prevent fire hazards. **NEVER!** smoke around or near the generator.



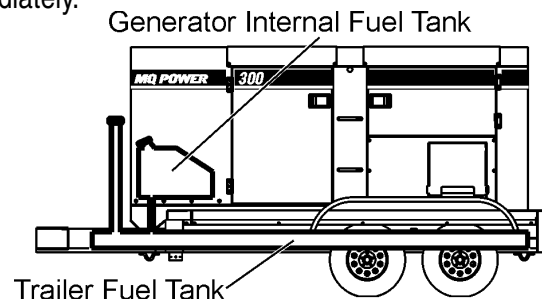
## REFILLING THE FUEL SYSTEM

The DCA300SSK series generators may (if equipped with a trailer or skid) have a **double fuel tank system** (Figure 31), which consists of an **internal** generator fuel tank, and a **trailer mounted** fuel tank. It is also possible the generator can be equipped with a **skid mounted** fuel tank (Figure 32). The skid type fuel system does not use the internal generator fuel tank.

Use the instructions in this section that applies to your type of fuel tank system.

**ALWAYS** fill the fuel tank with clean and fresh **#2 diesel fuel**. **DO NOT** fill the fuel tanks beyond their capacities.

Pay attention to the fuel tank capacity when replenishing fuel. The fuel tank cap must be closed tightly after filling. Handle fuel in a safety container. If the container does not have a spout, use a funnel. Wipe up any spilled fuel immediately.

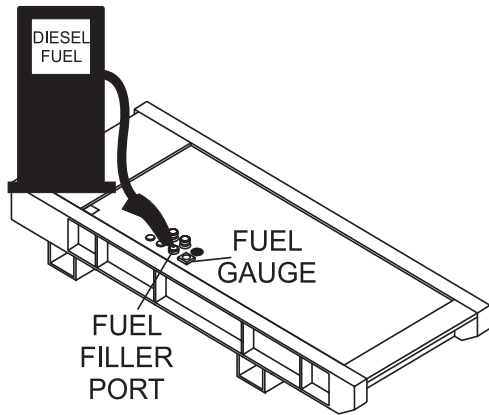


**Figure 31. Double Fuel Tank System**

### WARNING:



**ONLY properly trained personnel** who have read and understand this section should refill the double fuel tank system. Use **#2 diesel fuel**.



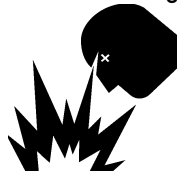
**Figure 32. Skid Type Fuel Tank System**

**Refueling Procedure:**

**DANGER:**



**Diesel fuel** and its vapors are dangerous to your health and the surrounding environment. Avoid skin contact and/or inhaling fumes.

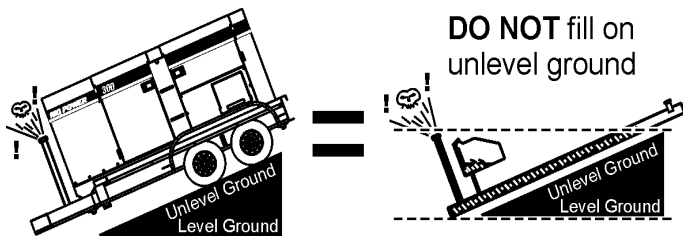


1. **Level Tanks** – make sure fuel cells are level with the ground. Failure to do so will cause fuel to spill from the tank before reaching full capacity. See Figure 33.

**WARNING:**



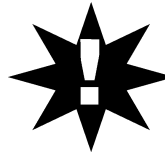
**ALWAYS!** place trailer on firm level ground before refueling.



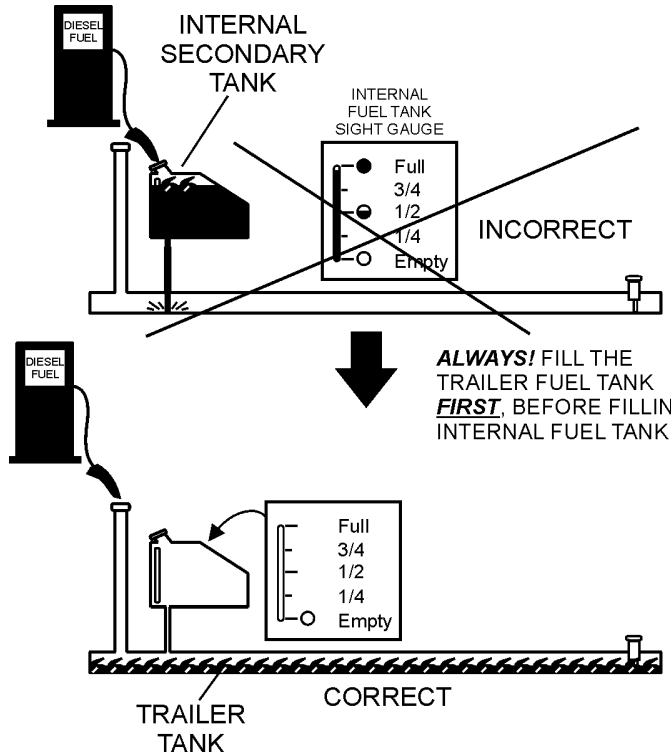
**Figure 32. Only Fill on Level Ground**

2. **Trailer Fuel Tank First** – The trailer fuel tank is the primary fuel tank and holds a larger capacity of fuel. The fuel in the trailer will be filtered and sent to the engine. **ALWAYS** fill trailer fuel tank (Figure 34) first.

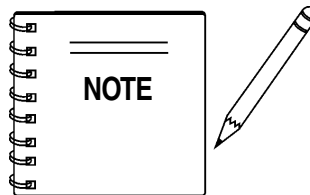
**CAUTION:**



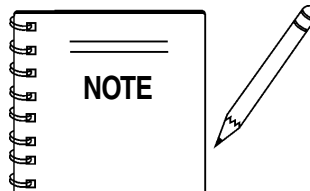
**ALWAYS!** fill trailer tank *first* with **#2 diesel fuel**, before filling secondary internal tank.



**Figure 34. Fuel Tank Filling Order**



**ONLY!** use **#2 diesel fuel** when refueling.



Fuel from the secondary inner tank will eventually drain into the primary trailer tank.

3. **NEVER overfill trailer fuel tank** – It is important to read the trailer fuel gauge when filling trailer fuel tank. **DO NOT** wait for fuel to rise in filler neck. See Figure 35.

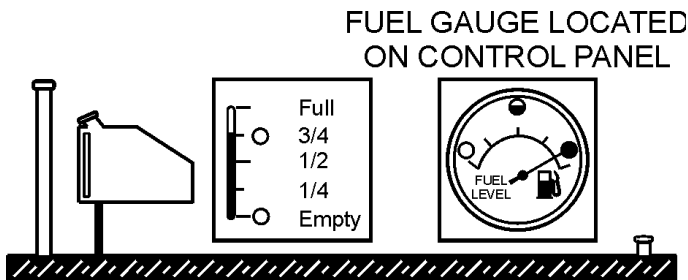


Figure 35. Full Trailer Tank

5. Figure 37 below reflects a full fuel system.

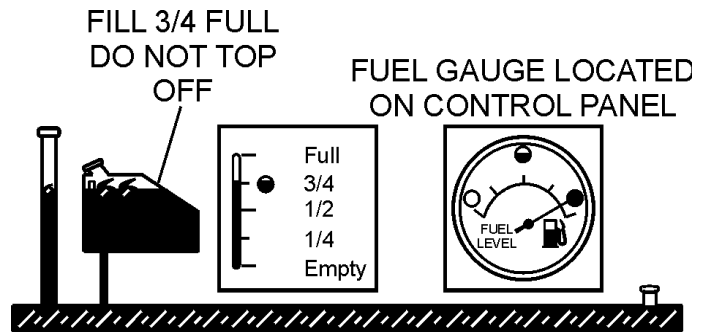


Figure 37. Full Fuel System

## WARNING:



**DO NOT OVER-FILL** fuel system. Leave room for fuel expansion. Fuel expands when heated.

4. Once the trailer tank is full, the **secondary inner tank** can be filled (See Figure 36). Notice how the trailer filler tube level rises when the internal tank is filled.

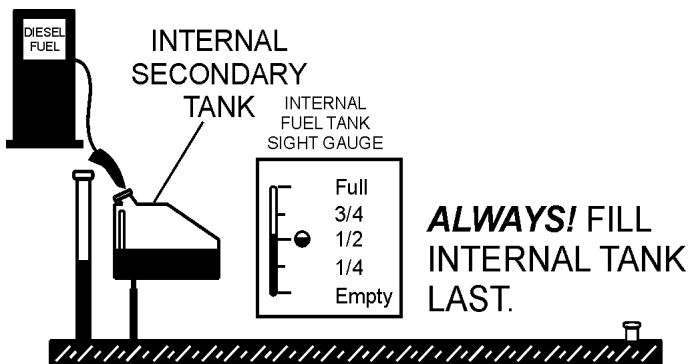


Figure 36. Filling Secondary Internal Fuel Tank

6. Fuel from the engine return line will drain into the secondary internal fuel tank. This fuel will eventually drain into the primary trailer tank in order to return to the engine.

## WARNING:



It is recommended to only fill the internal secondary tank to 3/4 full in order to allow for fuel return, fuel expansion, and to avoid spillage. See Figure 38 for fuel expansion.

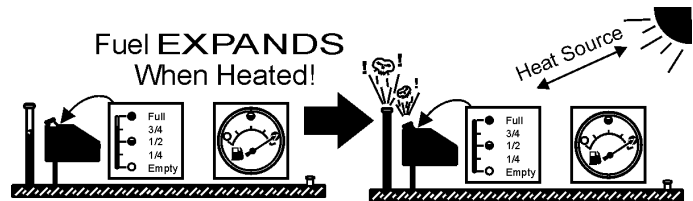


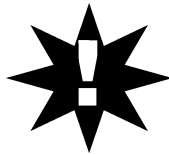
Figure 38. Fuel Expansion

## Coolant (Ethylene Glycol [Green] / Water — 50/50 mix)

Use only drinkable tap water. If hard water or water with many impurities is used, the inside of the engine and radiator may become coated with deposits and cooling efficiency will be reduced.

An anticorrosion additive added to the water will help prevent deposits and corrosion in the cooling system. See the engine manual for further details.

### CAUTION:



If adding coolant/antifreeze mix to the radiator, **DO NOT** remove the radiator cap until the unit has completely cooled. The possibility of **hot!** coolant exists which can cause severe burns.



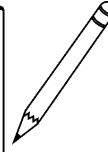
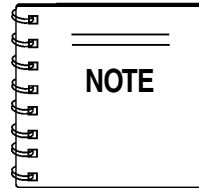
Day-to-day addition of coolant is done from the recovery tank. When adding coolant to the radiator, **DO NOT** remove the radiator cap until the unit has completely cooled. See Table 11 for engine and radiator, coolant capacities. Make sure the coolant level in the recovery tank is always between the "H" and the "L" markings.

Table 11. Coolant Capacity	
Engine Type	Coolant Capacity
Komatsu SA6D125E-2	8.5 Gal. (32.6 Liters)
Komatsu SAA6D125E-2	9.8 Gal. (37.0 Liters)

## Operation Freezing Weather

When operating in freezing weather, be certain the proper amount of antifreeze (Table 12) has been added.

Table 12. Anti-Freeze Operating Temperatures				
Vol % Anti-Freeze	Freezing Point		Boiling Point	
	°C	°F	°C	°F
40	-24	-12	106	222
50	-37	-34	108	226



When the antifreeze is mixed with water, the antifreeze mixing ratio **must be** less than 50%.

## Cleaning the Radiator

The engine may overheat if the radiator fins become overloaded with dust or debris. Periodically clean the radiator fins with compressed air. Cleaning inside the machine is dangerous, so clean only with the engine turned off and the **negative** battery terminal disconnected.

## Air Cleaner

Periodic cleaning/replacement is necessary. Inspect it in accordance with the **Komatsu Engine Owner's Manual**.

## Fan Belt Tension

A slack fan belt may contribute to overheating, or to insufficient charging of the battery. Inspect the fan belt for damage and wear and adjust it in accordance with the **Komatsu Engine Owner's Manual**.

The fan belt tension is proper if the fan belt bends 10 to 15 mm (Figure 39) when depressed with the thumb as shown below.

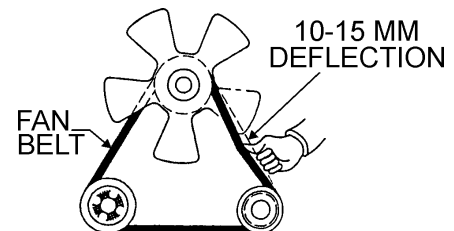
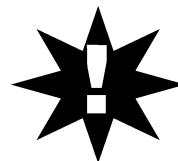


Figure 39. Fan Belt Tension



**NEVER!** place hands near the belts or fan while the generator set is running.



## Battery

This unit is of negative ground **DO NOT** connect in reverse. Always maintain battery fluid level between the specified marks. Battery life will be shortened, if the fluid level are not properly maintained. Add only distilled water when replenishment is necessary.

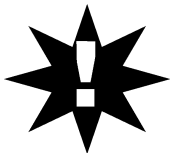
**DO NOT** over fill. Check to see whether the battery cables are loose. Poor contact may result in poor starting or malfunctions. **Always** keep the terminals firmly tightened. Coating the terminals with an approved battery terminal treatment compound. Replace battery with only recommended type battery.

The battery is sufficiently charged if the specific gravity of the battery fluid is 1.28 (at 68° F). If the specific gravity should fall to 1.245 or lower, it indicates that the battery is dead and needs to be recharged or replaced.

### Battery Cable Installation

**ALWAYS** be sure the battery cables (Figure 40) are properly connected to the battery terminals as shown below. The **RED** cable is connected to the positive terminal of the battery, and the **BLACK** cable is connected to the negative terminal of the battery.

## CAUTION:



**ALWAYS** disconnect the negative terminal **FIRST** and reconnect negative terminal **LAST**.

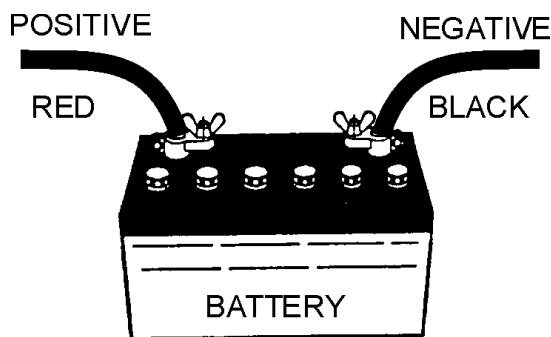
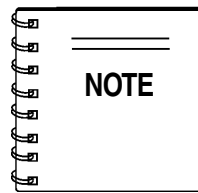


Figure 40. Battery Connections

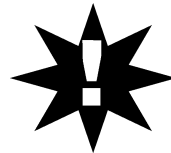
When connecting battery do the following:

1. **NEVER** connect the battery cables to the battery terminals when the **ignition** switch is in either the **Pre-Heat, RUN, or START** position. **ALWAYS** make sure that the ignition switch is in the **STOP** position when connecting the battery.
2. Place a small amount of battery terminal treatment compound around both battery terminals. This will ensure a good connection and will help prevent corrosion around the battery terminals.



If the battery cable is connected incorrectly, electrical damage to the generator will occur. Pay close attention to the polarity of the battery when connecting the battery.

## CAUTION:



Inadequate battery connections may cause poor starting of the generator, and create other malfunctions.

## Alternator

The polarity of the alternator is negative grounding type. When an inverted circuit connection takes place, the circuit will be in short circuit instantaneously resulting the alternator failure.

**DO NOT** put water directly on the alternator. Entry of water into the alternator leads an electrolyte corrosion causing an alternator failure.

Before charging the battery with an external electric source, be sure to disconnect the battery cables.

## Wiring

Inspect the entire generator for bad or worn electrical wiring or connections. If any wiring or connections are exposed (insulation missing) replace wiring immediately.

## Piping and Hose Connection

Inspect all piping, oil hose, and fuel hose connections for wear and tightness. Tighten all hose clamps and check hoses for leaks.

If any hose (**fuel** or **oil**) lines are defective replace them **immediately**.

# DCA-300SSK SERIES — GEN. START-UP PROCEDURE (MANUAL)

## WARNING:



The engine's exhaust contains harmful emissions. **ALWAYS have adequate ventilation when operating.** Direct exhaust away from nearby personnel.

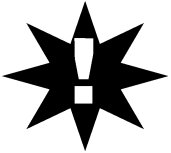
If applicable perform the following:

- Apply commercial power to the internal battery charger receptacle (to ensure good starting) via commercial power. An external power cord will be required. This capability is an **option**.
- Apply commercial power to the jacket water heater receptacle (not necessary for warm climates) via commercial power. An external power cord will be required. This capability is an **option**.

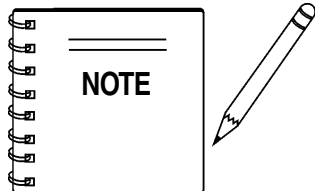
## BEFORE STARTING

### Generator and Control Panel

## CAUTION:



**NEVER!** manually start the engine with the **main, GFCI or auxiliary** circuit breakers in the **ON (closed)** position.



Steps 1 thru 19 are referenced for Engine Operating Panel up to S/N 3701673. See Figure 41 below. This unit has an **ignition switch** and a **throttle handle**.

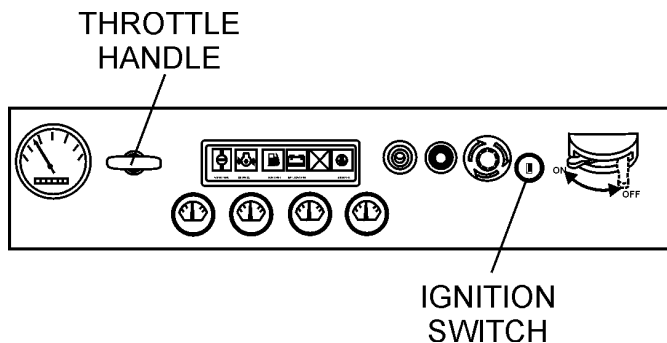


Figure 41. Engine Operating Panel Up To S/N 3701673

1. Place the **main, G.F.C.I.** and **aux.** circuit breakers (Figure 42) in the “**OFF**” position prior to starting the engine.

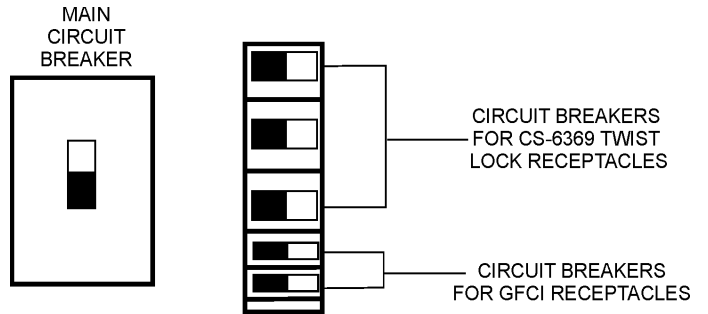


Figure 42. Main, Aux. and GFCI Circuit Breakers (OFF)

2. Connect the load to the **UVWO** terminals or **auxiliary receptacles** as shown in Figure 43. These load connection points can be found on the output terminal panel. To gain access to the UVWO terminals or other power receptacles, unlock the access cover and lift the door.
3. The UVWO terminals are protected by a plastic cover, remove this cover to gain access to the terminals. Tighten terminal nuts securely to prevent load wires from slipping out.

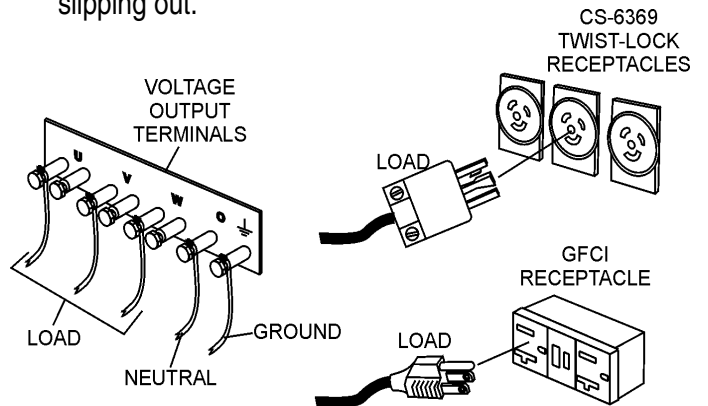


Figure 43. Load Connections

4. Close all engine enclosure doors (Figure 44).

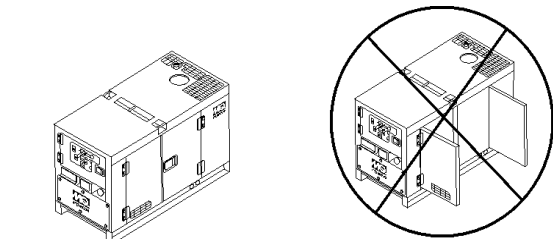
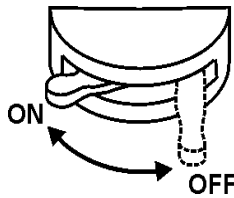


Figure 44. Engine Enclosure Doors

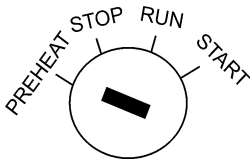
# DCA-300SSK SERIES — GENERATOR START-UP PROCEDURE (MANUAL)

5. Set the **battery ON/OFF switch** (Figure 45) to the “ON” position.



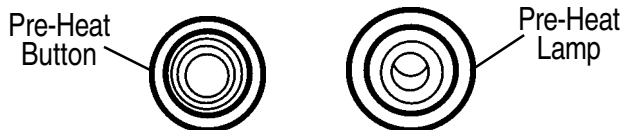
**Figure 45. Battery ON/OFF Switch**

6. When starting the generator in **COLD** weather conditions, turn the **ignition key** to the “PREHEAT” position (Figure 46),



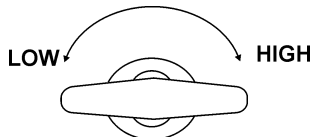
**Figure 46. Ignition Switch (Pre-Heat)**

7. Press and hold the engine preheat button (Figure 47) until the preheat lamp is lit (**ON**).



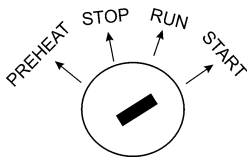
**Figure 47. Pre-Heat Button/ Lamp**

8. Place the **engine throttle control** in the “LOW” position (Figure 48).



**Figure 48. Engine Throttle Control**

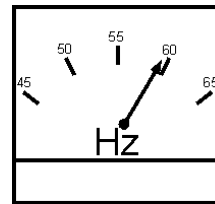
9. Turn the ignition key to the “**START**” position (Figure 49) and listen for the engine to begin cranking. After the engine starts release the ignition key.



**Figure 49. Engine Ignition Switch**

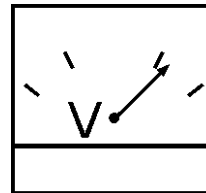
10. Once the engine has started, let it run for 3-5 minutes, then turn the throttle handle control (Figure 48) to the “**HIGH**” position.

11. The generator's frequency meter (Figure 50) should be displaying the 60 cycle output frequency in **HERTZ**.

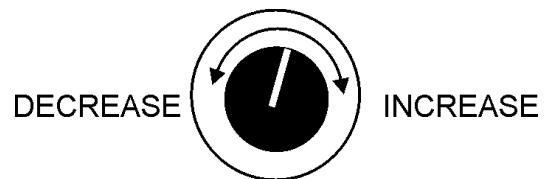


**Figure 50. Frequency Meter (Hz)**

12. The generator's AC-voltmeter (Figure 51) will display the generator's output in **VOLTS**. If the voltage is not within the specified tolerance, use the voltage adjustment control knob (Figure 52) to increase or decrease the desired voltage.

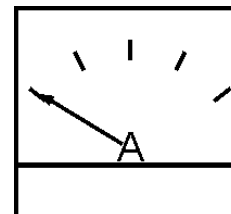


**Figure 51. Voltmeter**



**Figure 52. Voltage Adjust Control Knob**

13. The ammeter (Figure 53) will indicate zero amps with no load applied. When a load is applied, the ammeter will indicate the amount of current that the load is drawing from the generator.



**Figure 53. Ammeter (No Load)**

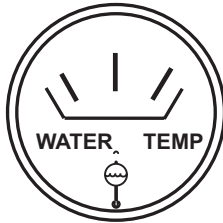
# DCA-300SSK SERIES — GENERATOR START-UP PROCEDURE (MANUAL)

14. The engine oil pressure gauge (Figure 54) will indicate the oil pressure (kg/ cm<sup>2</sup>) of the engine. Under normal operating conditions the oil pressure is approximately



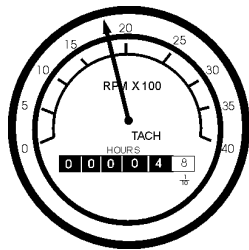
**Figure 54. Oil Pressure Gauge**

15. The *coolant temperature gauge* (Figure 55) will indicate the coolant temperature. Under normal operating conditions the coolant temperature should be between 165 and 215 degrees Fahrenheit (**Green Zone**).



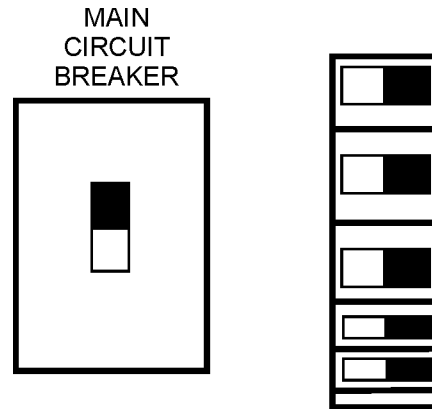
**Figure 55. Coolant Temperature Gauge**

16. The *tachometer gauge* (Figure 56) will indicate the speed of the engine when the generator is operating. Under normal operating conditions this speed is approximately 1800 RPM's.



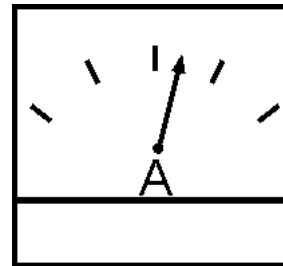
**Figure 56. Engine Tachometer Gauge**

17. Place the *main*, **GFCI**, and *aux.* circuit breakers in the “ON” position (Figure 57).



**Figure 57. Main, Aux. and GFCI Circuit Breakers (ON)**

18. Observe the generator's ammeter (Figure 58) and verify it reads the anticipated amount of current with respect to the load. The ammeter will only display a current reading if a load is in use.



**Figure**

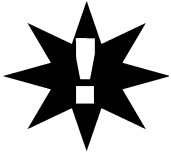
19. The generator will run until manually stopped or an abnormal condition occurs.

# DCA-300SSK SERIES — GENERATOR START-UP PROCEDURE (MANUAL)

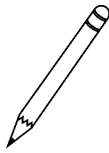
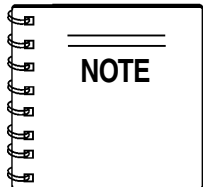
## BEFORE STARTING

### Generator and Control Panel

## CAUTION:



**NEVER!** manually start the engine with the *main*, *GFCI* or *auxiliary* circuit breakers in the **ON** (*closed*) position.



Steps 20 thru 26 are referenced for Engine Operating Panel S/N 3701674~. See Figure 59 below. This unit does not have an ignition switch or a throttle handle. It does have an **“engine speed switch”** that is used in conjunction with the MPEC unit.

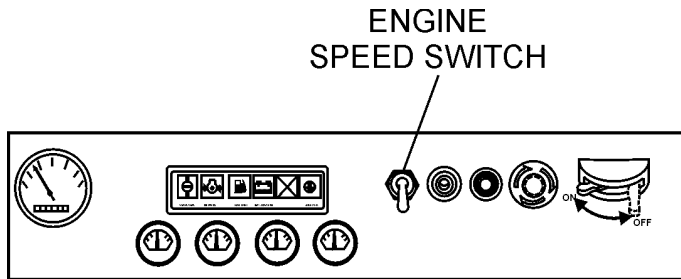


Figure 59. Engine Operating Panel S/N 3701674~

20. Set the **battery ON/OFF switch** (Figure 60) to the **“ON”** position.

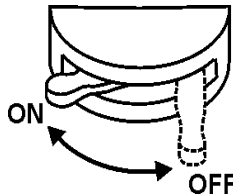


Figure 60. Battery ON/OFF Switch

21. Press and hold the engine preheat button (Figure 61) until the preheat lamp is lit (**ON**).

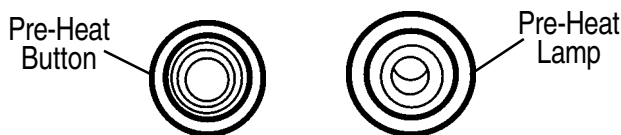


Figure 61. Pre-Heat Button/ Lamp

22. Place the engine speed switch in the **“LOW”** position (Figure 62).

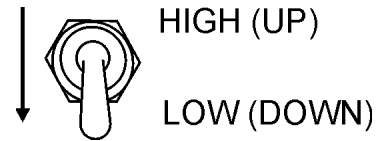


Figure 62. Engine Speed Switch (High)

23. Place the Auto-Off/Reset-Manual switch in the **“Manual”** position to start the engine (Figure 63). Once the engine starts, let the engine run for 1-2 minutes. Listen for any abnormal noises.

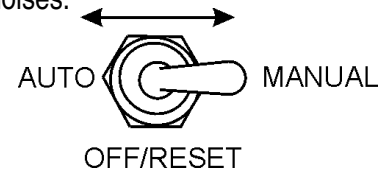


Figure 63. Auto-Off/Reset-Manual Switch

24. Once the engine is warm and the engine is running properly, place the engine speed switch in the **“HIGH”** position (Figure 64).

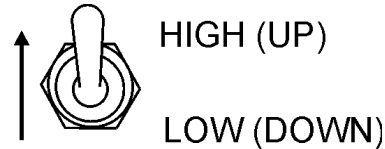


Figure 64. Engine Speed Switch (High)

25. Verify that the **“Engine Running”** status LED on the MPEC unit (Figure 65) is **“ON”** (lit) after the engine has been started.

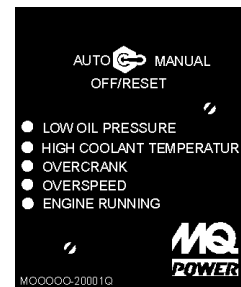


Figure 65. Engine Running LED (ON)

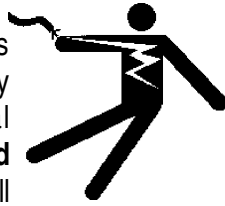
26. Continue operating the generator as outlined in steps 11 thru 19 (pages 44-45).

# DCA-300SSK SERIES — GEN. START-UP PROCEDURE (AUTO MODE)

## DANGER:

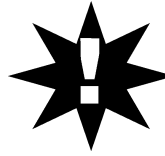


Before connecting this generator to any building's electrical system, a **licensed electrician** must install



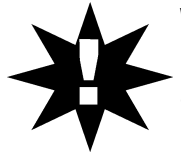
an **isolation (transfer) switch**. Serious **injury** or **death** may result without the installation of a transfer switch.

## CAUTION:

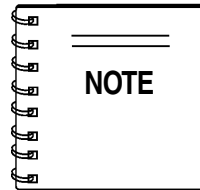


The **Engine Speed Switch** must be set to the "**High**" position when running in the **Auto-Start** mode. Failing to set the switch in the proper position can result in damage to your generator when it turns on.

## CAUTION:



When connecting the generator to a isolation (transfer) switch, **ALWAYS** have power applied to the generator's internal battery charger. This will ensure that the engine will not fail due to a dead battery.



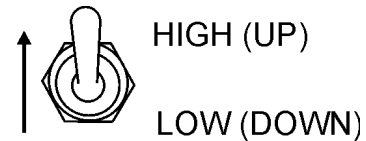
When the generator is set in the "**AUTO**" mode, the generator will **automatically start** in the event of commercial power falling below a prescribed level by means of a contact closure that is generated automatically by a transfer switch.

## WARNING:



When running the generator in the **AUTO** mode, remember the generator can start up at any time without warning. **NEVER** attempt to perform any maintenance when the generator is in the auto mode.

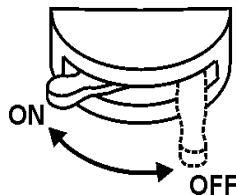
- Set the engine speed switch (Figure 67) to the "**High**" position.



**Figure 67. Engine Speed Switch (High)**

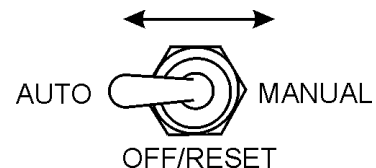
When starting generator in **AUTO** mode use the "**Manual Start-up**" procedure except where noted (see below).

- Perform steps 1 through 4 in the **Before Starting** section (page 43) as outlined in the **Manual Starting Procedure**.
- Set the **battery ON/OFF switch** (Figure 66) to the "**ON**" position.



**Figure 66. Battery ON/OFF Switch**

- Place the Off/Manual/Auto switch (Figure 68) on the MPEC unit to the **AUTO** position.



**Figure 68. Off/Manual Auto Switch (AUTO)**

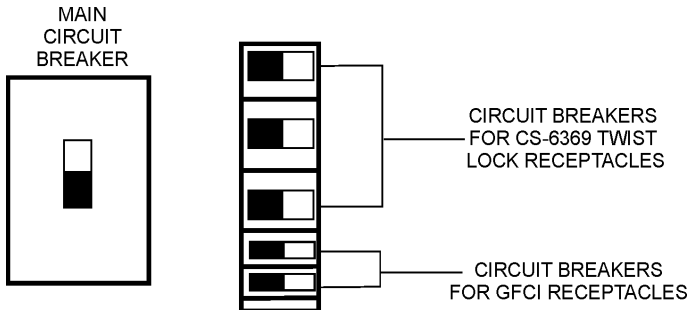
- Continue operating the generator as outlined in steps 11 thru 19 (pages 44-45).

# DCA-300SSK SERIES — GEN. SHUT-DOWN PROCEDURE (MANUAL)

## Engine Shutdown Ignition Key (Up to S/N 3701673)

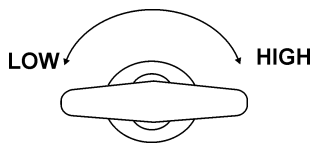
To shutdown the generator use the following procedure:

1. Place both the **MAIN**, **GFCI** and **LOAD** circuit breakers (Figure 69) to the "OFF" position.



**Figure 69. Main, Aux. and GFCI Circuit Breakers (OFF)**

2. Place the throttle control (Figure 70) in the "LOW" position.



**Figure 70. Engine Throttle Control**

3. Let the engine cool by running it for 3-5 minutes with no load applied.
4. Place the ignition key (Figure 71) in the "STOP" position.

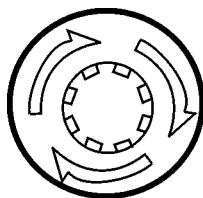


**Figure 71. Ignition Key Switch (STOP position)**

5. Remove all loads from the generator.

## Emergency Shutdown Procedure

1. **PUSH** inward the **RED** emergency stop button located on the **engine operating panel** (Figure 72) to turn off the generator in the event of an emergency. This button is located on either Engine Operating Panel.

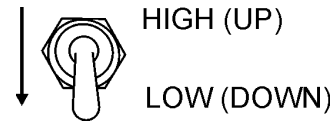


**Figure 72. Emergency Stop Button**

## Engine Shutdown Controller (S/N 3701674~)

To shutdown the generator use the following procedure:

1. Place both the **MAIN**, **GFCI** and **LOAD** circuit breakers as shown in Figure 67 to the "OFF" position.
2. Place the engine speed switch in the "LOW" position (Figure 73).



**Figure 73. Engine Speed Switch (High)**

3. Let the engine cool by running it for 3-5 minutes with no load applied.
4. Place the Auto-Off/Reset-Manual switch (Figure 74) to the **OFF/Reset** position.

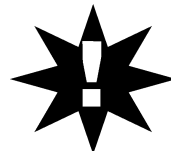
(Center Position OFF)



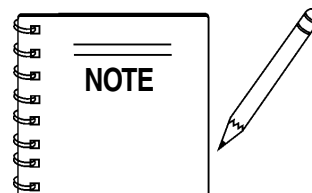
**Figure 74. Off/Manual Auto Switch**

5. Verify that the **all** status LED on the MPEC display are "OFF" (not lit).
6. Remove all loads from the generator.

## CAUTION:



**NEVER** stop the engine suddenly except in an emergency. **DO NOT** use the emergency stop switch as a method of shutting down the generator. This switch is **ONLY** to be used in the event of an emergency.



To disengage the emergency stop function, pull the emergency stop button outward to its original position. This will allow the generator to operate normally. Remember the generator will not start if the emergency stop button is engaged.



# DCA-300SSK SERIES — MAINTENANCE

Use Table 13 shown below as a general checklist to be performed on a daily basis.



TABLE 13. INSPECTION / MAINTENANCE		10 Hrs DAILY	250 Hrs	500 Hrs	1000 Hrs
<b>ENGINE</b>	Check Engine Fluid Levels	X			
	Check Fuel Filter	X			
	Check Air Cleaner Dust Indicator	X			
	Check for Leaks/Visual Walk Around	X			
	Check for Loosening of Parts	X			
	Replace Engine Oil and Filter *1		X		
	Service Battery		X		
	Clean Unit, Inside and Outside		X		
	Change Fuel Filter *2			X	
	Clean Radiator and Check Coolant Protection Level			X	
	Replace Air Filter Element				X
	Test Thermostats				X
	Check all Hoses and Clamps/Flush Radiator				X
	Clean Inside of Fuel Tank				X
<b>GENERATOR</b>	Measure Insulation Resistance Over 3M ohms		X		

\*1 Replace engine oil and filter at 100 hours, first time only.

\*2 Replace fuel filter at 250 Hours, first time only.

## General Inspection

Prior to each use, the generating set should be cleaned and inspected for deficiencies. Check for loose, missing or damaged nuts, bolts or other fasteners. Also check for fuel or oil leaks.

## Air Cleaner

Every **50 hours**: If dust indicator is **RED**, clean the air cleaner element.

### Outer Element:

1. Loosen wing bolt, remove dust cup, then remove wing nut and take out element.
2. Clean the inside of the body and cover using a damp cloth.
3. Blow dry with compressed air (0.69Mpa {7kgf.cm<sup>2</sup>, 99.4 PSI} maximum) against the side of the element along the pleats. Then blow dry against outside along the pleats, then against inside again.
4. Remove one seal each time the element is cleaned.
5. Replace the outer element after cleaning it 6 times or after one year. Replace the outer element if indicator is red even after cleaning it.
6. Check the inner cylinder element clamping nut for looseness, and retighten if necessary.
7. If seal washer is damaged or the threads of wing nut are damaged, replace.
8. Remove evacuator valve and clean it with compressed air. Reinstall.

### Inner element (if equipped)

1. Remove the cover and outer element, then remove the inner element.
2. Cover the air connector opening (outer side) with clean cloth or cloth tape.
3. Clean the inside of the body. Remove air connector opening protection.
4. Install a new inner cylinder element to the cylinder and tighten the nut.
5. Install element.
6. After replacing the element, press the button of the dust indicator to return the red piston to its original position.

## Fuel Addition

Add diesel fuel (the grade may vary according to season and locations). Always pour through the mesh filter.

## Removing Water from the Tank

After prolonged use, water and other impurities accumulate in the bottom of the tank. Occasionally remove the drain cock and drain the contents. During cold weather, the greater the empty volume inside the tank, the easier it is for water to condense. This can be reduced by always keeping the tank as full as possible.

## Air Removal

If air enters the fuel injection system of a diesel engine, starting becomes impossible. After running out of fuel, or after disassembling the fuel system, bleed the system according to the following procedure.

To restart after running out of fuel, turn the key switch to the **“START”** position for 15-30 seconds. Try again, if needed. This unit is equipped with an automatic air bleeding system.

## Service Daily

If engine is operating in very dusty and dry grass conditions, a clogged air cleaner will result in high fuel consumption, loss of power and excessive carbon buildup in the combustion chamber.

## Cleaning the Fuel Strainer

Clean the fuel strainer if it contains dust or water. Remove dust or water in the strainer cap and wash it in diesel. Securely fasten the fuel strainer cap so that fuel will not leak. Check the fuel strainer every 200 hours of operation or once a month.

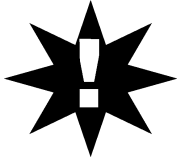
## Check Oil Level

Check the crankcase oil level prior to each use, or when the fuel tank is filled. Insufficient oil may cause severe damage to the engine. Make sure the generator is level. The oil level must be between the two notches on the dipstick as shown in Figure 29.

## Check Electric Heater (If equipped)

Before starting in cold weather (once a year), please contact your Komatsu distributor for inspection. Remove electric heater from the engine intake manifold and check for disconnections or dirt. When checking or installing the electric heater, replace the gasket with a new part.

## CAUTION:



Allow engine to **cool** when flushing out radiator. Flushing the radiator while **hot!** will damage radiator. In addition the possibility of **hot!** coolant exists which can cause severe burns.

### Flushing Out Radiator and Changing Coolant

1. Stop the engine and allow to cool. Tighten valve of the corrosion resistor (if equipped).
2. Turn water filler cap slowly and remove it.
3. Prepare a container to catch the coolant, then open drain plug of the radiator or heat exchanger and drain plug of the engine, and drain the coolant.
4. After draining the coolant, close drain plugs and fill with tap water.
5. When the water level is near the mouth of the water filler, open drain plugs and start the engine, and run at low idling. Keep the engine running at low idling and flush the radiator for about 10 minutes.
6. Adjust the flow of the water flowing in and draining out to ensure that the radiator is always full during the flushing operation. While flushing water through the system, watch carefully the water inlet hose does not come out of the radiator filler port.
7. After flushing, stop the engine, open drain plug and drain the water, then close drain plugs.
8. After draining the water, flush the system with a flushing agent. See instructions on flushing agent label.
9. After flushing, open drain plugs and drain out all the water, then close drain plugs and add tap water so the water level is near the mouth of the water filler.
10. When the water level is near the mouth of the water filler, open drain plugs and start the engine, run at low idling and continue to flush the system until clean water comes out. Adjust the flow of the water flowing in and draining out to ensure the radiator is always full during the flushing operation.
11. When clean water comes out, stop the engine, drain all the water, then close drain plugs.
12. Remove the corrosion resistor (if equipped) and open valve.
13. Supply water until it flows over the water filler.

14. Drain the water inside reserve tank, clean the inside of the reserve tank, then fill with coolant/water mixture to between the full and low lines.
15. Stop the engine, wait for 3 minutes, add tap water until the water level reaches near the water filler port, then tighten the radiator cap.

### Changing Oil

1. Make sure the oil is cool before changing.
2. Set a container directly under the drain plug of the oil pan. Loosen the drain plug slowly.
3. Check the drained oil for excessive metal particles or foreign material. Contact the distributor if there is metal particles or foreign material.
4. Using a filter wrench, turn filter cartridge to the left to remove it. If the filter cartridge is filled with a large amount of oil, wait 10 minutes or so before removing. Make sure there is no old gasket stuck on the filter holder.
5. Tighten drain plug. Clean the filter holder, fill the new filter cartridge with clean engine oil, coat the packing and thread of the new filter cartridge with engine oil, then install it to the filter holder. Tighten until the gasket surface contacts the seal surface of the filter holder, then tighten it a further 3/4 to 1 turn.
6. Add engine oil through oil filler until the oil level is between the H and L marks on the dipstick.
7. Run the engine at idling for a short time, then stop the engine. Recheck the oil level and fill as necessary.

### Replacing Fuel Filter

1. Set the container under the filter cartridge to catch fuel.
2. Using a filter wrench, turn the filter cartridge to the left to remove it.
3. Clean the filter holder, fill the new filter cartridge with fuel, coat the packing surface of the filter cartridge with engine oil, then install the cartridge to the filter holder.
4. When installing, tighten until the packing surface contacts the seal surface of the filter holder then tighten a further 2/3 of a turn. If the filter cartridge is tighten too much, the packing will be damaged and will cause fuel leakage. Fuel leakage will occur if the filter cartridge is not tightened enough. Always tighten to the correct angle.

5. After replacing filter cartridge, loosen air bleed plug.
6. Loosen the knob of feed pump, and pump it up and down until no bubbles come out with the fuel from air bleed plug.
7. After bleeding the air, tighten air bleed plug, then push in the knob of feed pump and lock it in position.
8. Replace Corrosion resistor cartridge (if equipped)
9. Screw in valves at the top of the corrosion resistor.
10. Using a filter wrench, turn the cartridge to the left to remove it.
11. Coat the seal surface of the new cartridge with engine oil and install it to the filter holder.
12. Tighten until the packing surface contacts the seal surface of the filter holder, then tighten a further 2/3 of a turn.
13. Open valves.

## **Cleaning Breather Element**

1. Loosen the clamp, then remove the hose and take out breather. Wipe off the dirt around the breather. Check the O-ring, and replace if necessary.
2. Wash the breather in diesel fuel or flushing oil, blow dry with compressed air, then reinstall it.
3. Inspect the hose and if there is any deteriorated oil stuck inside the hose. Replace hose if necessary.

## **Greasing**

1. Using a grease pump, grease the fan hub (1 place) and tension pulley (2 places).

## **Generator Storage:**

For storage of the generator for over 30 days, the following is required:

- Fill the fuel tank completely. Treat with fuel stabilizer if necessary.
- Completely drain oil from the crankcase and refill if necessary with fresh oil.
- Clean the entire generator, internal and external.
- Disconnect the negative terminals of the battery and cover it, or remove it from the generator and store it separately.
- If the ambient temperature is expected to drop below 0°C, add antifreeze to the radiator.
- Cover the generator set and store in a clean, dry place

## **Removal From Long Term Storage:**

- Apply oil to the engine valve and rocker arms, and examine the operating condition of the valves.
- Remove the oil filler pipe from the turbocharger oil inlet port, add 0.5-1L (0.13-0.26 gal) of oil to the turbocharger, reinstall the oil filler pipe.
- Change the oil in engine oil pan.
- Replace all the filters.
- Flush the inside of the cooling system.
- Drain the water from the fuel tank and bleed the air from the fuel system.
- If the engine has not been started for more than one year, contact your Komatsu distributor to have engine overhauled.

## Jacket Water Heater and Internal Battery Charger 120 VAC Input Receptacles (OPTIONAL)

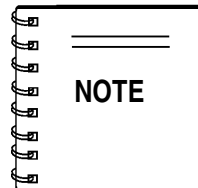
This generator is equipped with two 120 VAC, 20 amp input receptacles located on the output terminal panel.

The purpose of these receptacles is to provide power via commercial power to the *jacket water heater* and *internal battery charger*.

These receptacles will **ONLY** function when commercial power has been supplied to them (Figure 75). To apply commercial power to these receptacles, a power cord of adequate size will be required (See Table 6).

When using the generator in *hot* climates there is no reason to apply power to jacket water heater. However, if the generator will be used in *cold* climates it is always a good idea to apply power to the jacket water heater at all times. To apply power to the jacket water heater simply apply power to the jacket water heater receptacle via commercial power using an power cord of adequate size.

If the generator will be used daily, the battery should normally not require charging. If the generator will be idle (not used) for long periods of time, apply power to the battery charger receptacle via commercial power using an power cord of adequate size.



To ensure adequate starting capability, **always** have power applied to the generator's *internal battery charger*.

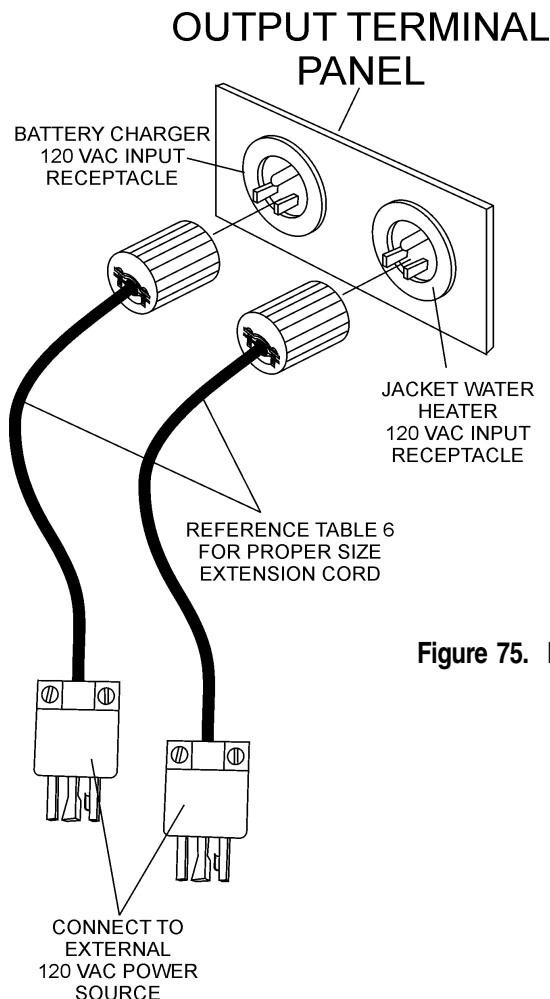


Figure 75. Battery Charger/Jacket Water Heater Power Connections

# DCA-300SSK SERIES —TRAILER BRAKES MAINTENANCE E

## Brakes

Trailer brakes should be inspected the **first 200 miles** of operation. This will allow the brake shoes and drums to seat properly. After the first 200 mile interval, inspect the brakes **every 3,000 miles**. If driving over rough terrain, inspect the brakes more frequently.

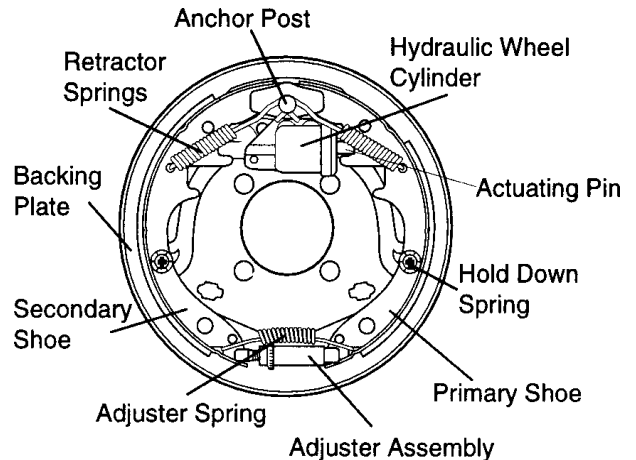
Figure 76 displays the major hydraulic surge brake components that will require inspection and maintenance. Use Table 14 as a basic trouble shooting guide when brake problems occur. Please inspect these components as required using steps 1 through 6 as listed below:

## Brake Adjustment

1. Place the trailer on jack stands. Make sure the jack stands are placed on secure level ground.
2. Check the wheel and drum for free rotation.
3. Remove the adjusting hole cover from the adjusting slot at the bottom brake backing plate.
4. With a screwdriver or standard adjusting tool, rotate the star wheel of the adjuster assembly to expand the brake shoes.
5. Adjust the brake shoes outward until the pressure of the lining against the wheel drum makes the wheel difficult to turn.
6. Adjust, rotate the star wheel in the opposite direction until the wheel rotates freely with slight lining drag.
7. Replace the adjusting hole cover and lower the trailer to the ground.
8. Repeat steps 1 through 7 on the remaining brakes.

## Hydraulic Surge Brakes

Hydraulic surge brakes should not require any special attention with the exception of routine maintenance such as shoe and lining replacement. Brake lines should be periodically checked for cracks, kinks, or blockage.



**Figure 76. Hydraulic Brake Components**

## Actuator

Hydraulic surge braking requires the installation of an actuator at the tongue of the trailer. Remember the **surge** or **push** of the trailer toward the tow vehicle automatically synchronizes the trailer brakes with the tow vehicle brakes. As the trailer pushes against the tow vehicle the actuator telescopes together and applies force to the master cylinder, supplying hydraulic pressure to the trailer brakes.

Periodically check and test the surge “**actuator**” to make sure that it is functioning correctly. Never use an undersize actuator.

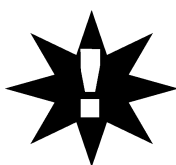
**Table 14. Hydraulic Brake Troubleshooting**

Symptom	Possible Cause	Solution
No Brakes	Brake line broken or kinked?	Repair or replace.
Weak Brakes or Brakes Pull to One Side	Brake lining glazed?	Reburnish or replace.
	Trailer overloaded?	Correct weight.
	Brake drums scored or grooved?	Machine or replace.
	Tire pressure correct?	Inflate all tires equally.
	Tires unmatched on the same axle?	Match tires.
Locking Brakes	Brake components loose, bent or broken?	Replace components.
	Brake drums out-of-round?	Replace.
Noisy Brakes	System lubricated?	Lubricate.
	Brake components correct?	Replace and correct.
Dragging Brakes	Brake lining thickness incorrect or not adjusted correctly?	Install new shoes and linings.
	Enough brake fluid or correct fluid?	Replace rubber parts fill with dot 4 fluid.

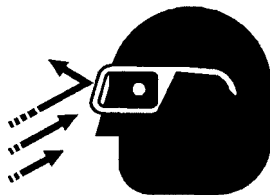
## Tires/Wheels/Lug Nuts

Tires and wheels are a very important and critical components of the trailer. When specifying or replacing the trailer wheels it is important the wheels, tires, and axle are properly matched.

### CAUTION:



**DO NOT** attempt to repair or modify a wheel. **DO NOT** install an inner tube to correct a leak through the rim. If the rim is cracked, the air pressure in the inner tube may cause pieces of the rim to explode (break off) with great force and cause serious eye or bodily injury.

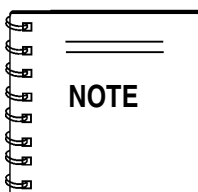
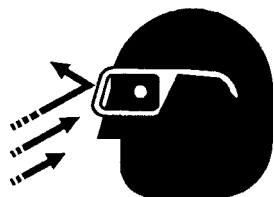
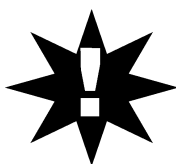


### Tire Wear/Inflation

Tire inflation pressure is the most important factor in tire life. Pressure should be checked cold before operation **DO NOT** bleed air from tires when they are *hot!* Check inflation pressure weekly during use to insure the maximum tire life and tread wear.

Table 15 (Tire Wear Troubleshooting) will help pinpoint the causes and solutions of tire wear problems.

### CAUTION:



**ALWAYS** wear safety glasses when removing or installing force fitted parts. Failure to comply may result in serious injury.

TABLE 15. TIRE WEAR TROUBLESHOOTING

WEAR PATTERN		CAUSE	SOLUTION
	Center Wear	Over Inflation.	Adjust pressure to particular load per tire manufacturer.
	Edge Wear	Under Inflation.	Adjust pressure to particular load per tire manufacturer.
	Side Wear	Loss of camber or overloading.	Make sure load does not exceed axle rating. Align wheels.
	Toe Wear	Incorrect toe-in.	Align wheels.
	Cupping	Out-of-balance.	Check bearing adjustment and balance tires.
	Flat Spots	Wheel lockup & tire skidding.	Avoid sudden stops when possible and adjust brakes.

## Suspension

The *leaf suspension* springs and associated components (Figure 77) should be visually inspected **every 6,000** miles for signs of excessive wear, elongation of bolt holes, and loosening of fasteners. Replace all damaged parts (suspension) immediately. Torqued suspension components as detailed in Table 16.

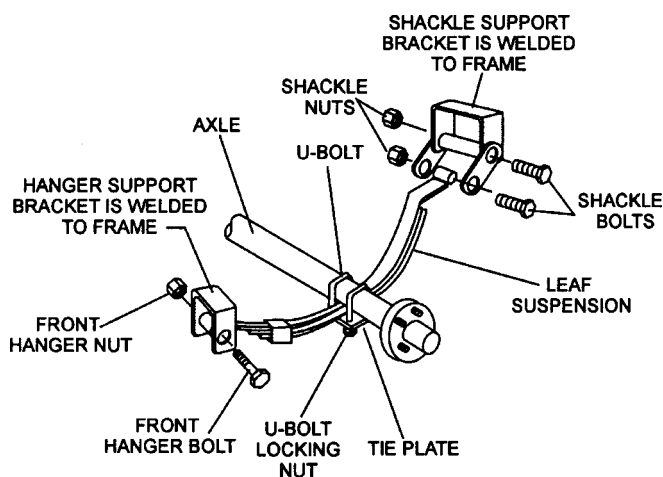


Figure 77. Major Suspension Components

# DCA-300SSK SERIES —TRAILER MAINTENANCE

**Table 16. Suspension Torque Requirements**

Item	Torque (Ft.-Lbs.)
3/8" U-BOLT	MIN-30 MAX-35
7/16" U-BOLT	MIN-45 MAX-60
1/2" U-BOLT	MIN-45 MAX-60
SHACKLE BOLT SPRING EYE BOLT	SNUG FIT ONLY. PARTS MUST ROTATE FREELY. LOCKING NUTS OR COTTER PINS ARE PROVIDED TO RETAIN NUT-BOLT ASSEMBLY.
SHOULDER TYPE SHACKLE BOLT	MIN-30 MAX-50

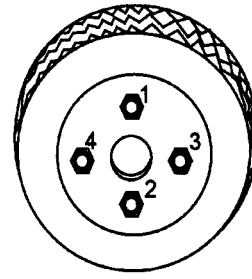
## Lug Nut Torque Requirements

It is extremely important to apply and maintain proper wheel mounting torque on the trailer. Be sure to use only the fasteners matched to the cone angle of the wheel. Proper procedure for attachment of the wheels is as follows:

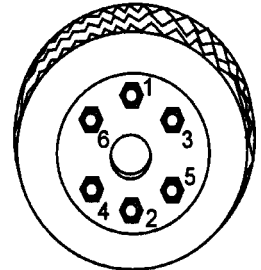
1. Start all wheel lug nuts by hand.
2. Torque all lug nuts in sequence. See Figure 78. **DO NOT** torque the wheel lug nuts all the way down. Tighten each lug nut in 3 separate passes as defined by Table 17.
3. After first road use, retorque all lug nuts in sequence. Check all wheel lug nuts periodically.

**Table 17. Tire Torque Requirements**

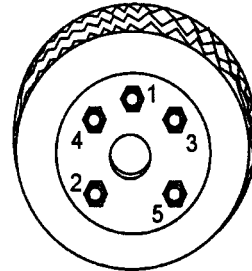
Wheel Size	First Pass FT-LBS	Second Pass FT-LBS	Third Pass FT-LBS
12"	20-25	35-40	50-65
13"	20-25	35-40	50-65
14"	20-25	50-60	90-120
15"	20-25	50-60	90-120
16"	20-25	50-60	90-120



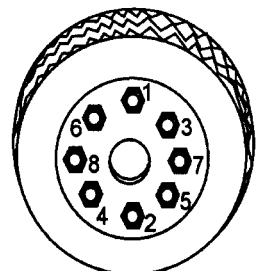
4-LUG NUTS



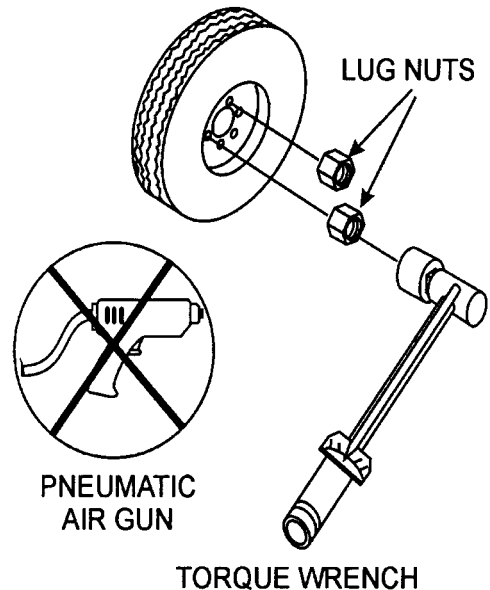
6-LUG NUTS



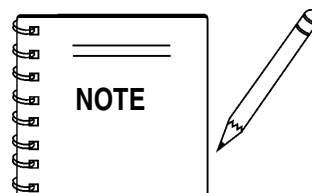
5-LUG NUTS



8-LUG NUTS



**Figure 78. Wheel Lug Nuts Tightening Sequence**

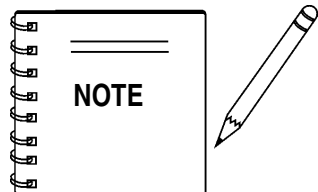
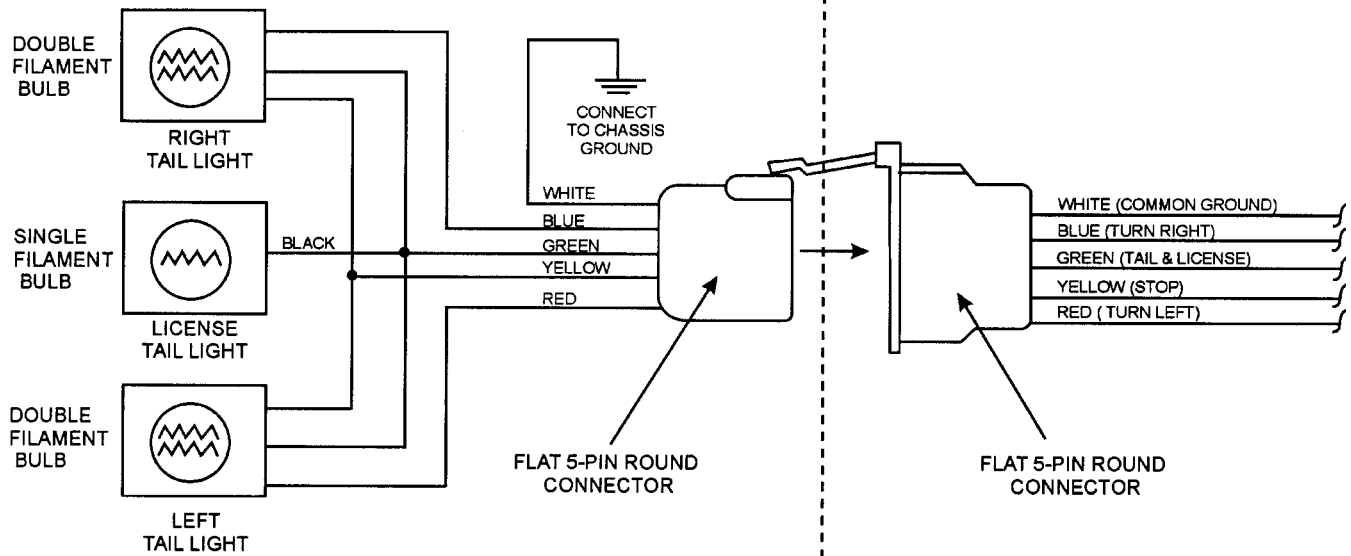
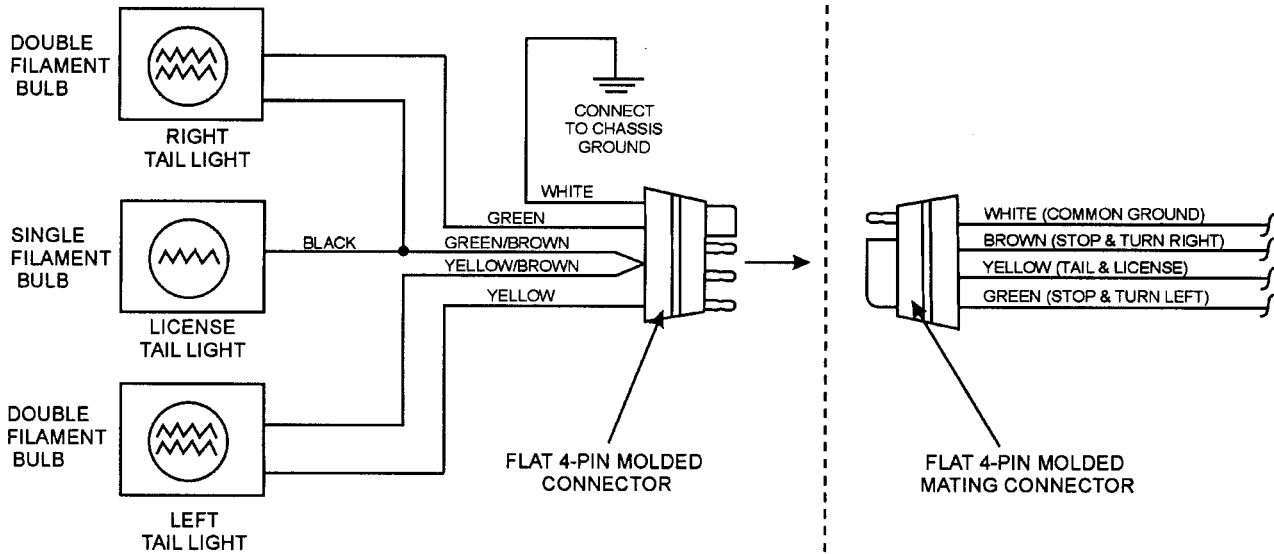


**NEVER** use an pneumatic air gun to tighten wheel lug nuts. Use a **torque wrench** to tighten lug nuts.

# DCA-300SSK — TRAILER-WIRING DIAGRAM

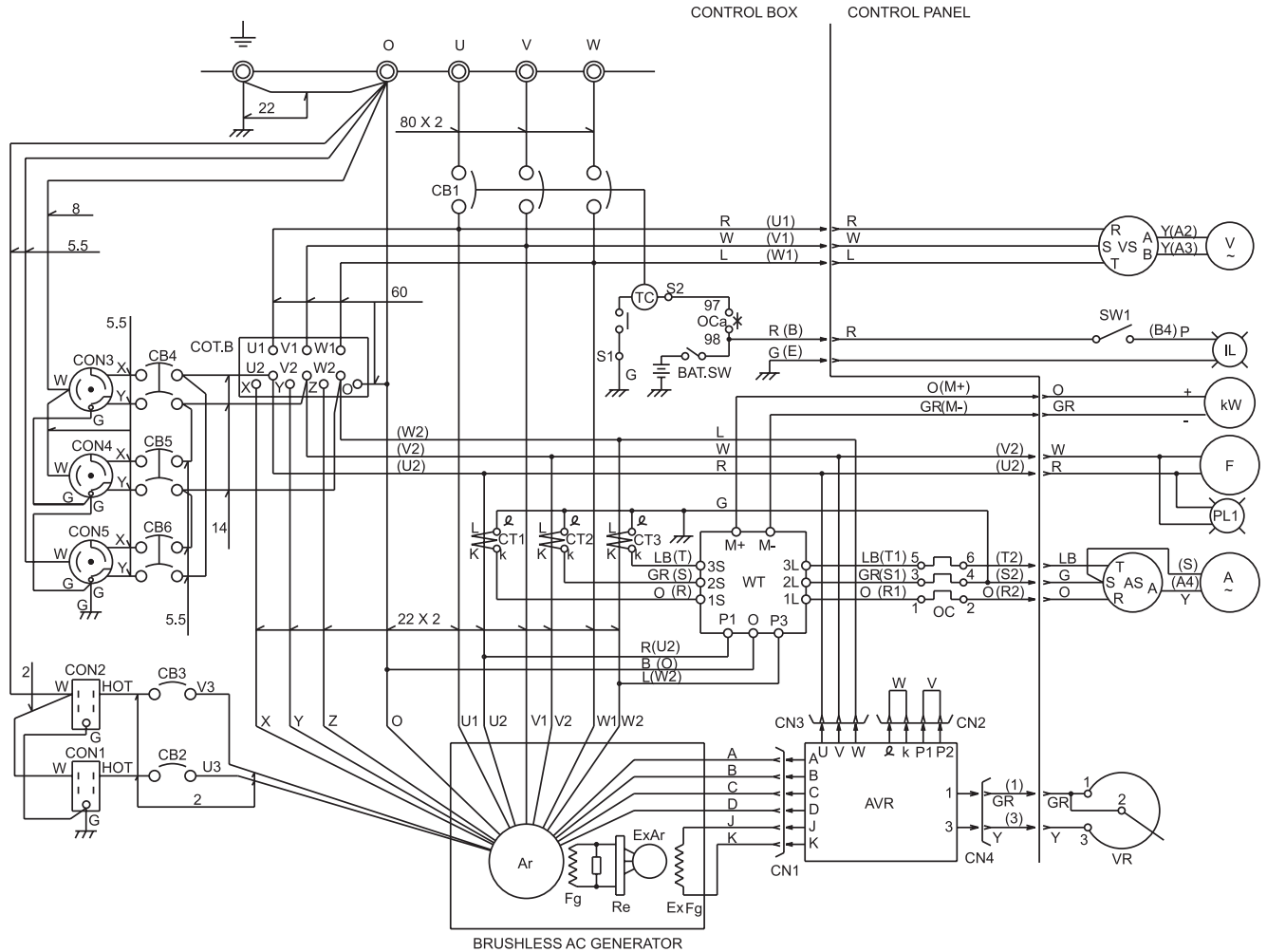
## TRAILER SIDE

## TOWING VEHICLE SIDE

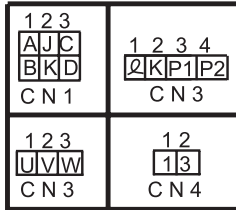


Trailer lights are oriented from the driver's seat.

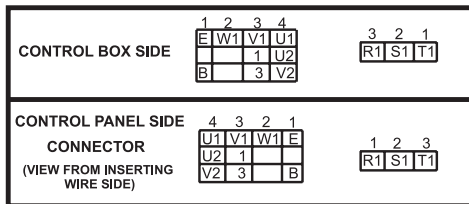
# DCA-300SSK — GENERATOR WIRING DIAGRAM



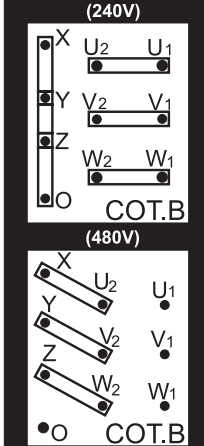
### AVR CONNECTOR



(VIEW FROM INSERTING WIRE SIDE)



### SETTING FOR OUTPUT VOLTAGE

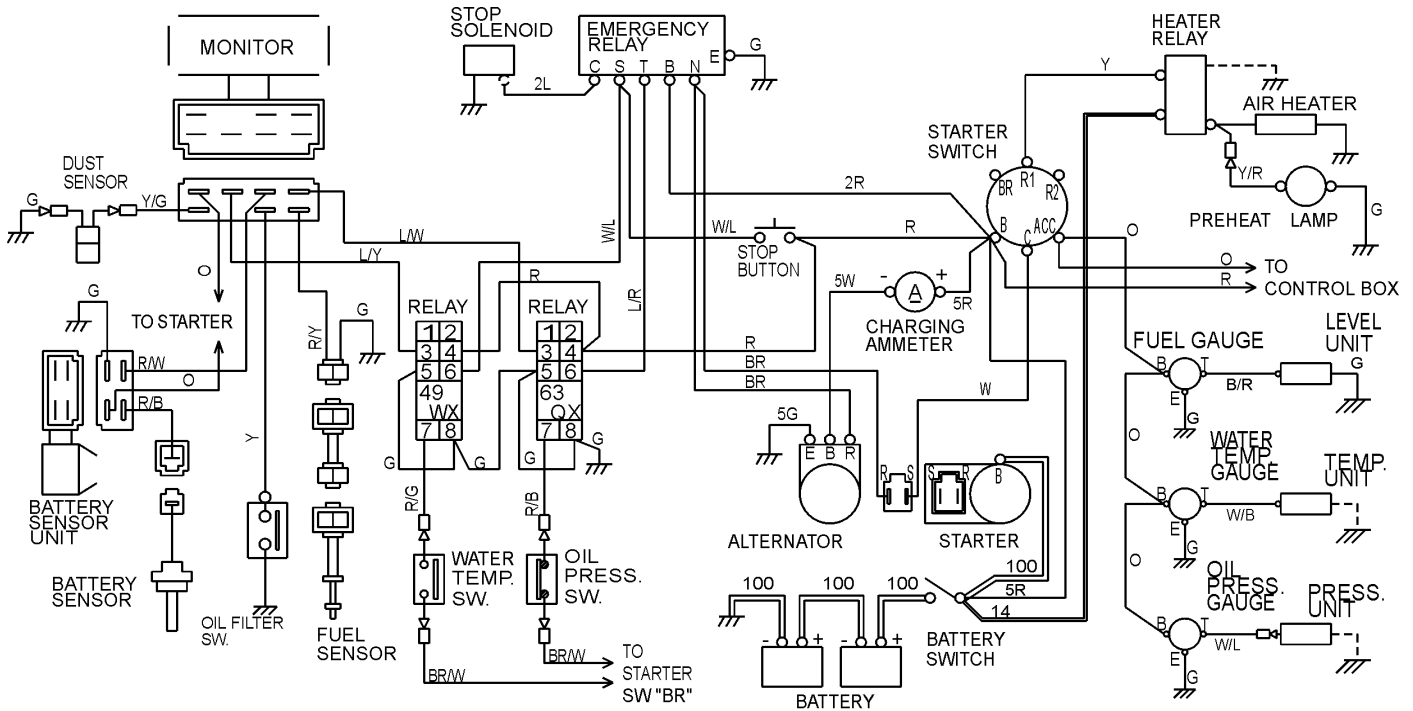


WIRE SIZE TABLE	
80:	80mm <sup>2</sup>
60:	60mm <sup>2</sup>
22:	22mm <sup>2</sup>
14:	14mm <sup>2</sup>
8:	8mm <sup>2</sup>
5.5:	5.5mm <sup>2</sup>
2:	2mm <sup>2</sup>
NO MARK: 1.25mm <sup>2</sup>	

COLOR CODE TABLE			
CODE/ WIRE COLOR			
B	BLACK	R	RED
L	BLUE	W	WHITE
BR	BROWN	Y	YELLOW
G	GREEN	LB	LIGHT BLUE
GR	GRAY	LG	LIGHT GREEN
V	VIOLET	O	ORANGE
P	PINK		

MARK	NAME
Ar	MAIN GENERATOR ARMATURE WINDING
Fg	MAIN GENERATOR FIELD WINDING
ExAr	EXCITER ARMATURE WINDING
ExFg	EXCITER FIELD WINDING
AVR	AUTOMATIC VOLTAGE REGULATOR
VR	VOLTAGE REGULATING RHEOSTAT
Re	RECTIFIER
CT1~3	CURRENT TRANSFORMER (400/5A)
C B 1	CIRCUIT BREAKER (600A)
OC	OVER CURRENT RELAY
COT. B	VOLTAGE CHANGE-OVER BOARD
AS	AMMETER CHANGE-OVER SWITCH
A	AC AMMETER (0~400, 800A)
VS	VOLTMETER CHANGE-OVER SWITCH
V	AC VOLTMETER (0~600V)
F	FREQUENCY METER (45~65HZ)
PI1	PILOT LAMP
CB2. 3	AUX. CIRCUIT BREAKER (20A)
CB4~6	AUX. CIRCUIT BREAKER (50A)
CON1. 2	AUX POWER RECEPTACLE (20A)
CON3~5	AUX POWER RECEPTACLE (50A)
IL	PANEL LIGHT
SW1	PANEL LIGHT SWITCH
kW	WATTMETER -20 ~200 KW
WT	WATT-METER TRANSDUCER

# DCA-300SSK — ENGINE WIRING DIAGRAM (UP TO S/N3696506)



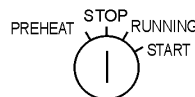
### CONNECTOR ARRANGEMENT

WIRE SIZE	COLOR CODE	
	WIRE COLOR	WIRE COLOR
100: 100mm <sup>2</sup>	B	BLACK
38: 38mm <sup>2</sup>	R	RED
22: 22mm <sup>2</sup>	L	BLUE
14: 14mm <sup>2</sup>	W	WHITE
5 : 5mm <sup>2</sup>	BR	BROWN
5 : 5mm <sup>2</sup>	Y	YELLOW
5 : 5mm <sup>2</sup>	G	GREEN
5 : 5mm <sup>2</sup>	LB	LIGHT BLUE
2 : 2mm <sup>2</sup>	GR	GRAY
2 : 2mm <sup>2</sup>	LG	LIGHT GREEN
NO MARK WIRE SIZE	V	VIOLET
NO MARK WIRE SIZE	O	ORANGE
NO MARK WIRE SIZE	P	PINK

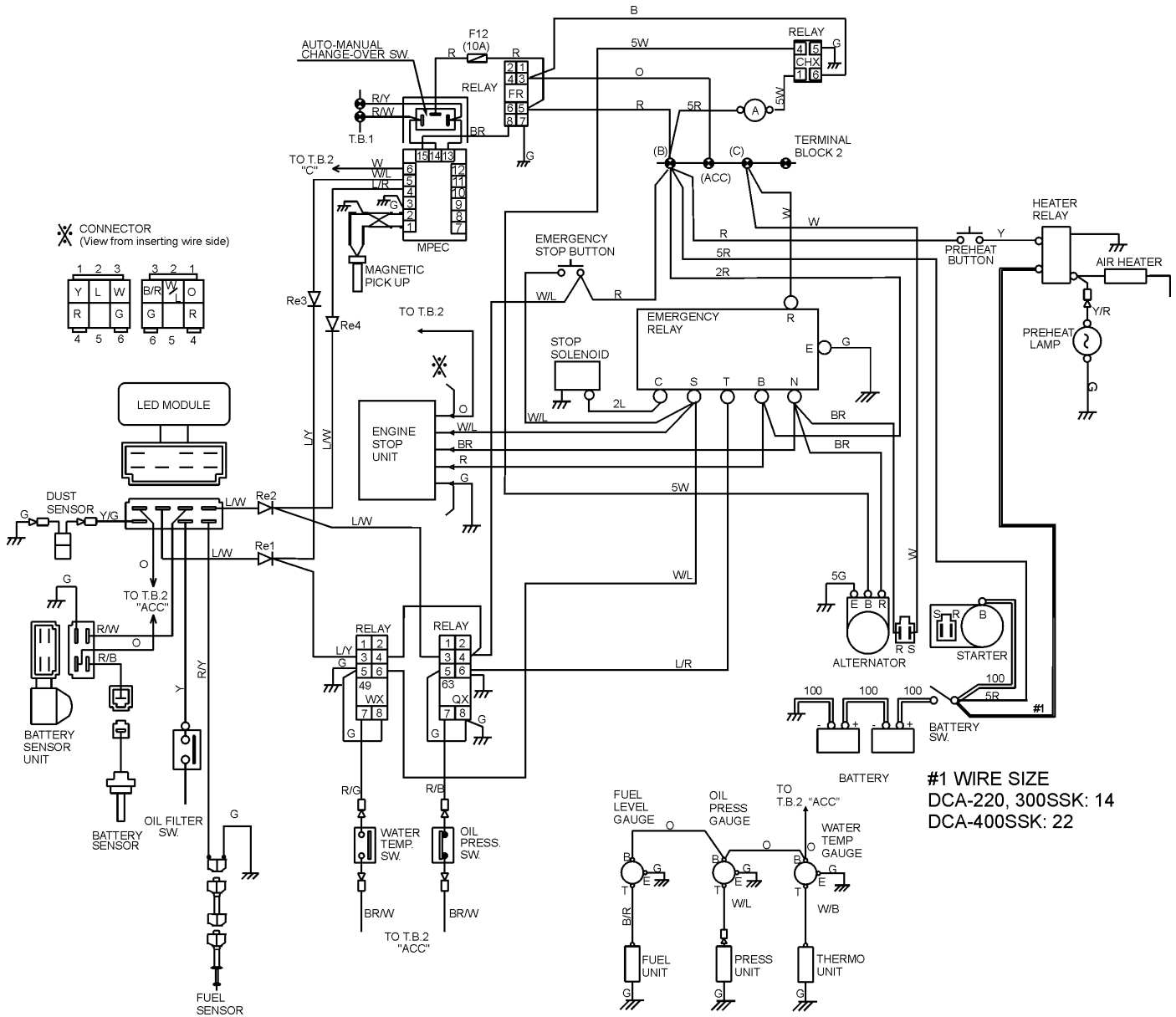
	STARTER SW CONNECTION					
	B	BR	R1	R2	C	ACC
STOP	○					
PREHEAT	○	○	○			○
RUNNING	○	○				○
START	○	○	○	○	○	

RELAY INSIDE CONNECTION

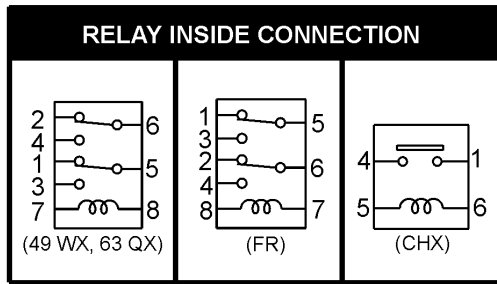
NOTE: WIRING VIEW



# DCA-300SSK — ENGINE WIRING DIAGRAM (S/N3696507 TO 3701673)

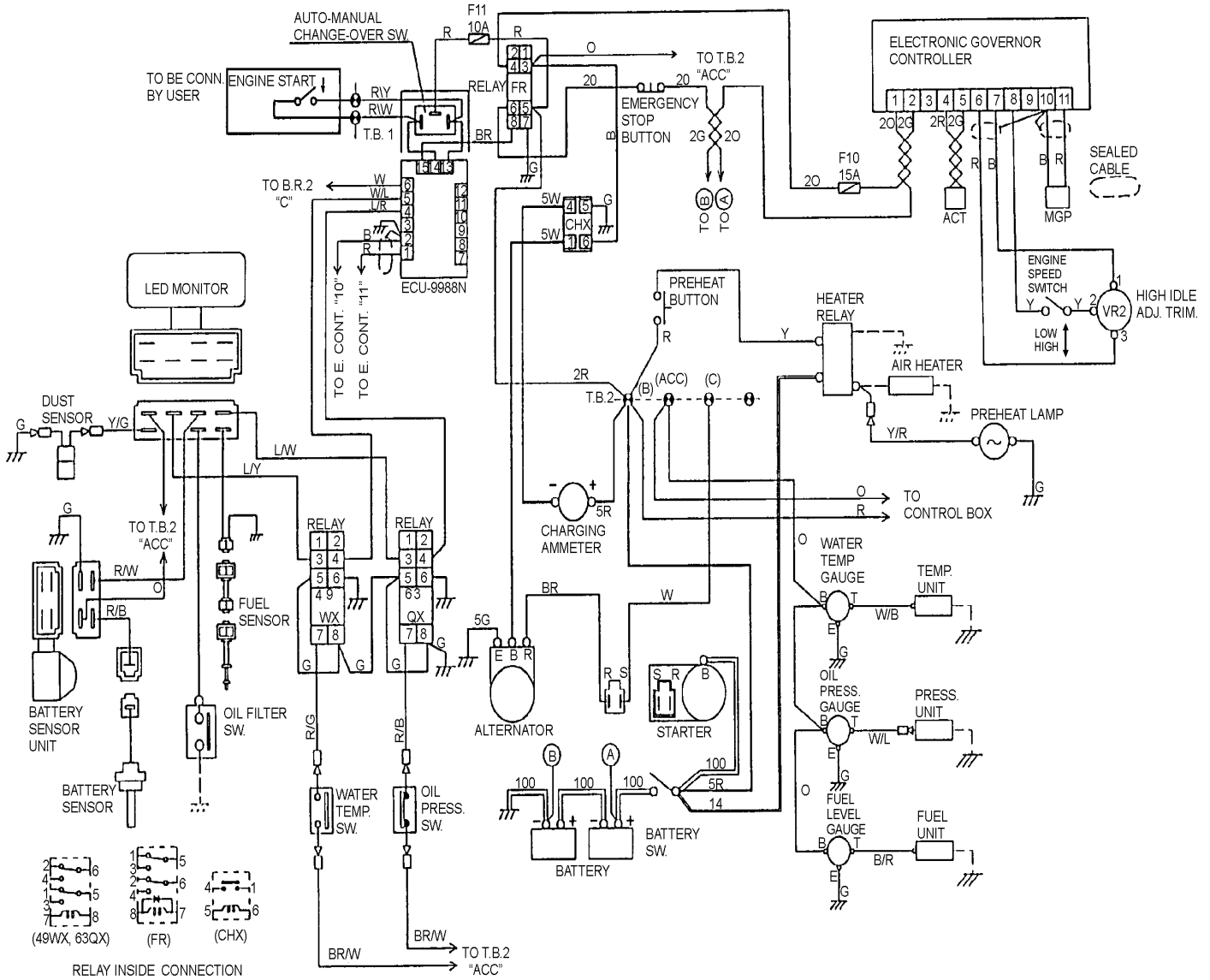


COLOR CODE TABLE			
CODE/ WIRE COLOR			
B	BLACK	R	RED
L	BLUE	W	WHITE
BR	BROWN	Y	YELLOW
G	GREEN	LB	LIGHT BLUE
GR	GRAY	LG	LIGHT GREEN
V	VIOLET	O	ORANGE
P	PINK		



WIRE SIZE	AREA (mm <sup>2</sup> )
100	100mm <sup>2</sup>
38	38mm <sup>2</sup>
22	22mm <sup>2</sup>
14	14mm <sup>2</sup>
5	5mm <sup>2</sup>
2	2mm <sup>2</sup>
NO MARK	2 mm <sup>2</sup>

# DCA-300SSK — ENGINE WIRING DIAGRAM (S/N3701674~)



## DCA-300SSK — TROUBLESHOOTING (ENGINE)

Practically all breakdowns can be prevented by proper handling and maintenance inspections, but in the event of a breakdown, use Table 18 (Engine Troubleshooting) as a basic guideline for troubleshooting the engine. If the problem cannot be remedied, consult our company's business office or service plant.

**TABLE 18. ENGINE TROUBLESHOOTING**

SYMPTOM	POSSIBLE PROBLEM	SOLUTION
Engine does not start.	No fuel?	Replenish fuel.
	Air in the fuel system?	Bleed system.
	Water in the fuel system?	Remove water from fuel tank.
	Fuel pipe clogged?	Clean fuel pipe.
	Fuel filter clogged?	Clean or change fuel filter.
	Excessively high viscosity of fuel or engine oil at low temperature?	Use the specified fuel or engine oil.
	Fuel with low cetane number?	Use the specified fuel.
	Fuel leak due to loose injection pipe retaining nut?	Tighten nut.
	Incorrect injection timing?	Adjust.
	Fuel cam shaft worn?	Replace.
	Injection nozzle clogged?	Clean injection nozzle.
	Injection pump malfunctioning?	Repair or replace.
	Seizure of crankshaft, camshaft, piston, cylinder liner or bearing?	Repair or replace.
	Compression leak from cylinder?	Replace head gasket, tighten cylinder head bolt, glow plug and nozzle holder.
	Improper valve timing?	Correct or replace timing gear.
	Piston ring and liner worn?	Replace.
Excessive valve clearance?	Adjust.	
Starter does not run.	Battery discharged?	Charge battery.
	Starter malfunctioning?	Repair or replace.
	Key switch malfunctioning?	Repair or replace.
	Wiring disconnected?	Connect wiring.

# DCA-300SSK — TROUBLESHOOTING (ENGINE)

## TABLE 18. ENGINE TROUBLESHOOTING (CONTINUED)

SYMPTOM	POSSIBLE PROBLEM	SOLUTION
Engine revolution is not smooth.	Fuel filter clogged or dirty?	Clean or change.
	Air cleaner clogged?	Clean or change.
	Fuel leak due to loose injection pipe retaining nut?	Tighten nut.
	Injection pump malfunctioning?	Repair or replace.
	Incorrect nozzle opening pressure?	Adjust.
	Injection nozzle stuck or clogged?	Repair or replace.
	Fuel over flow pipe clogged?	Clean.
	Governor malfunctioning?	Repair.
Either white or blue exhaust gas is observed.	Excessive engine oil?	Reduce to the specified level.
	Piston ring and liner worn or stuck?	Repair or replace.
	Incorrect injection timing?	Adjust.
	Deficient compression?	Adjust top clearance.
Either black or dark gray exhaust gas is observed.	Overload?	Lessen the load.
	Low grade fuel used?	Use the specified fuel.
	Fuel filter clogged?	Clean or change.
	Air cleaner clogged?	Clean or change.
	Deficient nozzle injection?	Repair or replace the nozzle.
Deficient output.	Incorrect injection timing?	Adjust.
	Engine's moving parts seem to be seizing?	Repair or replace.
	Uneven fuel injection?	Repair or replace the injection pump.
	Deficient nozzle injection?	Repair or replace the nozzle.
	Compression leak?	Replace head gasket, tighten cylinder head bolt, glow plug and nozzle holder.

# DCA-300SSK — TROUBLESHOOTING (GENERATOR)

Practically all breakdowns can be prevented by proper handling and maintenance inspections, but in the event of a breakdown, use Table 19 (Generator Troubleshooting) as a basic guideline for troubleshooting the generator. If the problem cannot be remedied, consult our company's business office or service plant.

**TABLE 19. GENERATOR TROUBLESHOOTING**

SYMPTOM	POSSIBLE PROBLEM	SOLUTION
No Voltage Output	AC Voltmeter defective?	Check output voltage using a voltmeter.
	Is wiring connection loose?	Check wiring and repair.
	Is AVR defective?	Replace if necessary.
	Defective Rotating Rectifier?	Check and replace.
Low Voltage Output	Is engine speed correct?	Turn engine throttle lever to "High".
	Is wiring connections loose?	Check wiring and repair.
	Defective AVR?	Replace if necessary.
High Voltage Output	Is wiring connections loose?	Check wiring and repair.
	Defective AVR?	Replace if necessary.
Circuit Breaker Tripped	Short Circuit in load?	Check load and repair.
	Over current?	Confirm load requirements and reduce.
	Defective circuit breaker?	Check and replace.
	Over current Relay actuated?	Confirm load requirement and replace.

# DCA-300SSK — TROUBLESHOOTING (ENGINE CONTROLLER)

**TABLE 20. ENGINE CONTROLLER TROUBLESHOOTING (MPEC)**

Sympton	Possible Cause	Solution
Low oil pressure light is on.	Low oil level?	Fill oil level.
	Oil pressure sending unit failure?	Replace oil pressure sending unit.
	Time delay malfuntion in Controller?	Refer to dealer.
	Wire shorted?	Inspect/repair wire.
Low coolant level light is on.	Low coolant level?	Fill coolant level.
	Sending unit failure?	Replace sending unit.
	Low battery voltage?	Replace/charge battery.
High coolant temperture light is on.	Fan belt tension incorrect?	Tighten/replace fan belt.
	Air flow is not circulation through radiator?	Clean/repair radiator grill.
	Doors open?	Close doors.
	Exhaust leaking?	Replace/repair gaskets or faulty part.
	Generator being overloaded?	Check/reduce load.
	Thermostat failure?	Replace thermostat.
	Air intake blocked?	Clear all air intakes.
	Temperature switch failure?	Replace temperature switch.
Overcrank light is on.	No or low Fuel?	Fill fuel level.
	Controller needs to be calibrated?	Refer to dealer.
Overspeed light is on.	RPM engine speed too high?	Adjust RPM.
	Governor actuator needs to be adjusted?	Adjust governor actuator.
	Governor controller needs to be adjusted?	Adjust governor controller.
	Engine Controller needs to be calibrated?	Refer to dealer.
Loss of MPU light(s) or on.	Magnetic pick up out of adjustment?	Adjust magnetic pick up.
	Magnetic pick up dirty?	Clean magnetic pick up.



## EXPLANATION OF CODE IN REMARKS COLUMN

How to read the marks and remarks used in this parts book.

### Items Found In the “Remarks” Column

**Serial Numbers**-Where indicated, this indicates a serial number range (inclusive) where a particular part is used.

**Model Number**-Where indicated, this shows that the corresponding part is utilized only with this specific model number or model number variant.

### Items Found In the “Items Number” Column

All parts with same symbol in the number column, \*, #, +, %, or >, belong to the same assembly or kit.

Note: If more than one of the same reference number is listed, the last one listed indicates newest (or latest) part available.

# DCA-300SSK — SUGGESTED SPARE PARTS

## DCA-300SSK W/KOMATSU SA6D125E-2/ SAA6D125E-2

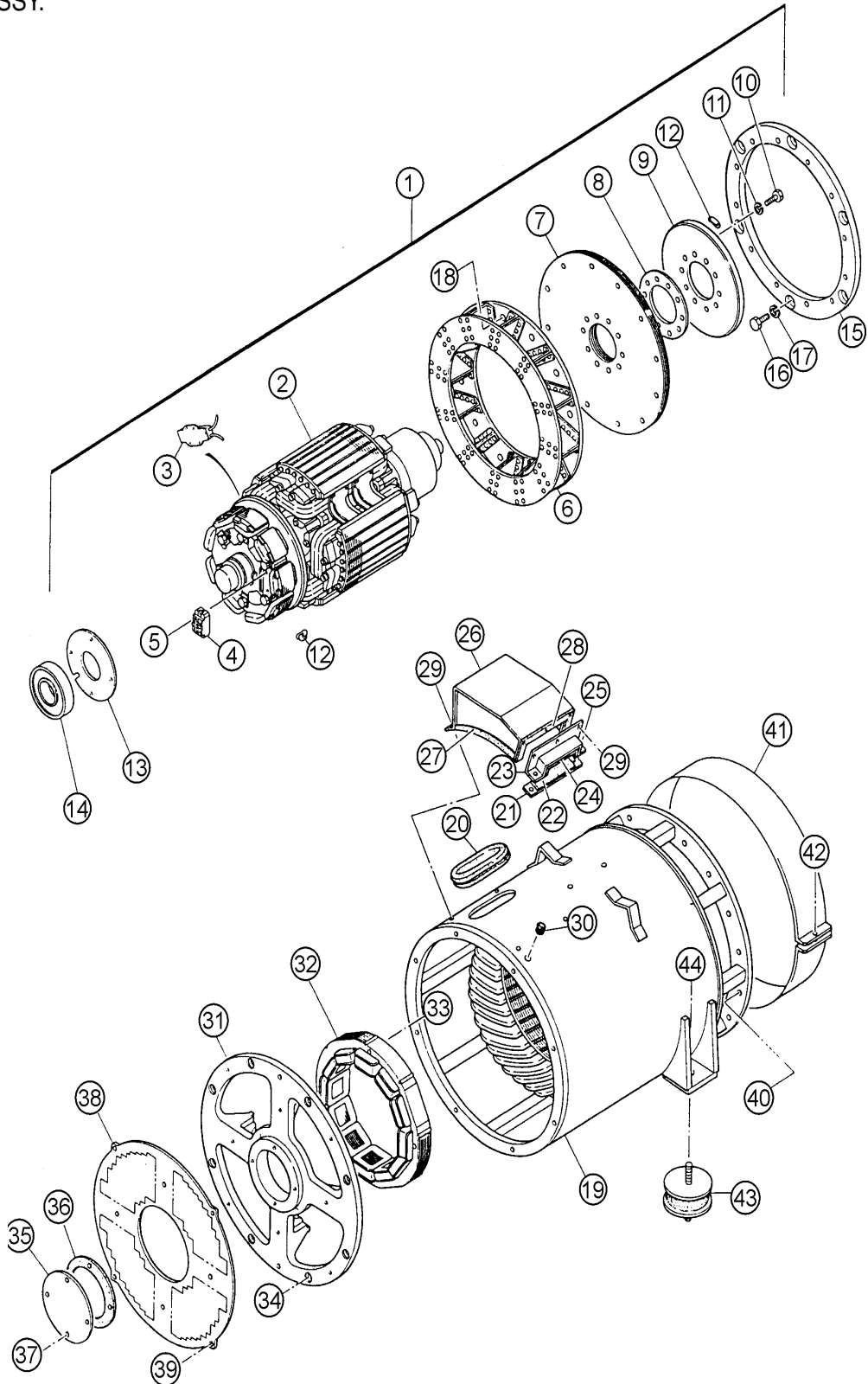
*1 to 5 Units*

Qty.	P/N	Description
10	6125817032	AIR FILTER, INNER & OUTER
10	6003118321	FUEL FILTER
10	6002111231	OIL FILTER
5	6004111151	CARTRIDGE, CORROSION RESISTOR
3	0810105400	FUEL FILTER, FUEL TANK
2	xxxxxxxxxx	ENGINE FAN BELT
1	6008155390	SWITCH, STARTER ..... UP TO S/N 370163
5	615	KEY SET, STARTER SWITCH (2) ..... UP TO S/N 370163
1	6152611520	RADIATOR HOSE (UPPER) ..... UP TO S/N 3708296
1	6152611531	RADIATOR HOSE (LOWER) ..... UP TO S/N 3708296
1	6152611530	RADIATOR HOSE (UPPER) ..... S/N 3708297~
1	6152621540	RADIATOR HOSE (LOWER) ..... S/N 3708297~
1	0605505030	FUEL CAP
1	0601850590	KEY, FUEL CAP
1	0601820625	AUTOMATIC VOLTAGE REGULATOR
1	0601810072	PILOT LAMP
2	0601810261	BULB, PILOT LAMP
1	23S0311150M	CAP, RADIATOR ..... UP TO S/N 3708296
1	0602122200	UNIT, OIL PRESSURE
1	0602123206	UNIT, WATER TEMPERATURE
1	0602121052	CHARGING AMMETER
1	0601804887	CIRCUIT BREAKER, OUTPUT
		..... TERMINAL, KM51, 265V 20A ..... UP TO S/N 3706720
1	0601808803	CIRCUIT BREAKER, OUTPUT
		..... TERMINAL, QOU120B 20A ..... TO S/N 3706721~
1	0601805840	CIRCUIT BREAKER, OUTPUT
		..... TERMINAL, KM52, 265V 50A ..... UP TO S/N 3706720
1	0601808804	CIRCUIT BREAKER, OUTPUT
		..... TERMINAL, QOU250B 50A ..... TO S/N 3706721~

**NOTE**  
**Part number on this Suggested Spare Parts list may supercede/replace the P/N shown in the text pages of this book.**

# DCA-300SSK GENERATOR ASSY.

GENERATOR ASSY.



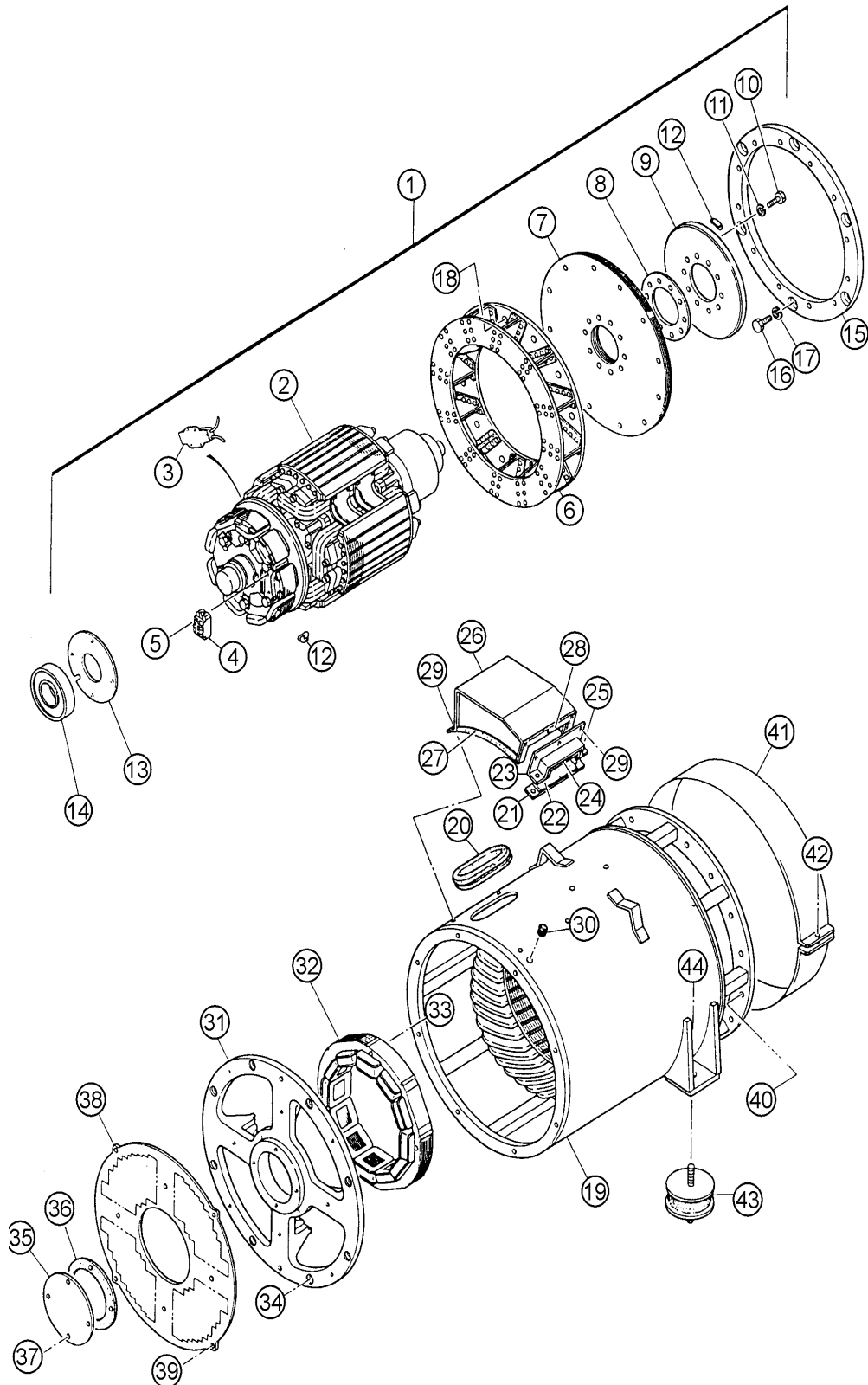
# DCA-300SSK GENERATOR ASSY.

## GENERATOR ASSY.

<u>NO.</u>	<u>PART NO.</u>	<u>PART NAME</u>	<u>QTY.</u>	<u>REMARKS</u>
1	C2110100302	ROTOR ASSY. ....	1	INCLUDES ITEM W/*
2*		FIELD ASSY.	1	
3*	0601842401	RESISTOR .....	2	80W 300K OHM
4*	0601823282	RECTIFIER .....	1	RM50TC-24
5*	0018205020	HEX. SOCKET HEAD CAP SCREW	2	
5*	0040005000	LOCK WASHER	2	
5*	0041205000	PLAIN WASHER	2	
6*	8201070002	FAN	1	
7*	8201611004	COUPLING DISK	12	
8*	C3164200004	WASHER, COUPLING HUD	1	
9*	8201015003	BALANCING PLATE .....	1	PURCHASE AS SET OF 1-14
10*	0012116045	HEX. HEAD BOLT	10	
11*	0042616000	LOCK WASHER	10	
12*	0601000209	BALANCING WEIGHT KIT	1	
13*	C3112500004	BEARING FLANGE	1	
14*	0071906315	BEARING .....	1	6315DDUC3
15	8201614003	COUPLING RING	1	
16	0012116040	HEX. HEAD BOLT	6	
17	0042516000	LOCK WASHER	6	
18	0012112040	HEX. HEAD BOLT	12	
18	0042512000	LOCK WASHER	12	
19	C2130100103	STATOR ASSY.	1	
20	0226200430	RUBBER SEAL	1	
21	8201323004	CLAMPER	1	
22	0223300140	RUBBER SEAL	1	
23	8201323103	CLAMPER	1	
24	0221200350	RUBBER SEAL	1	
25	0010110035	HEX. HEAD BOX	2	
25	0041210000	PLAIN WASHER	2	
26	C2132200003	COVER	1	
27	0226000275	RUBBER SEAL	2	
28	0225000500	RUBBER SEAL	1	
29	0017106016	HEX. HEAD BOLT	6	
30	0601850144	GROMMET	1	
31	C3154000002	END BRACKET	1	
32	C3138000003	FIELD ASSY. EXCITER	1	
33	0012110080	HEX. HEAD BOLT	4	
33	0042610000	LOCK WASHER	4	
33	0041210000	PLAIN WASHER	4	
34	0017112045	HEX. HEAD BOLT	8	
35	C3154300104	COVER, BEARING	1	
36	C3154300004	GASKET, BEARING	1	
37	0010106060	HEX. HEAD BOLT	4	
37	0040006000	LOCK WASHER	4	
37	0041206000	PLAIN WASHER	4	

# DCA-300SSK GENERATOR ASSY.

## GENERATOR ASSY.



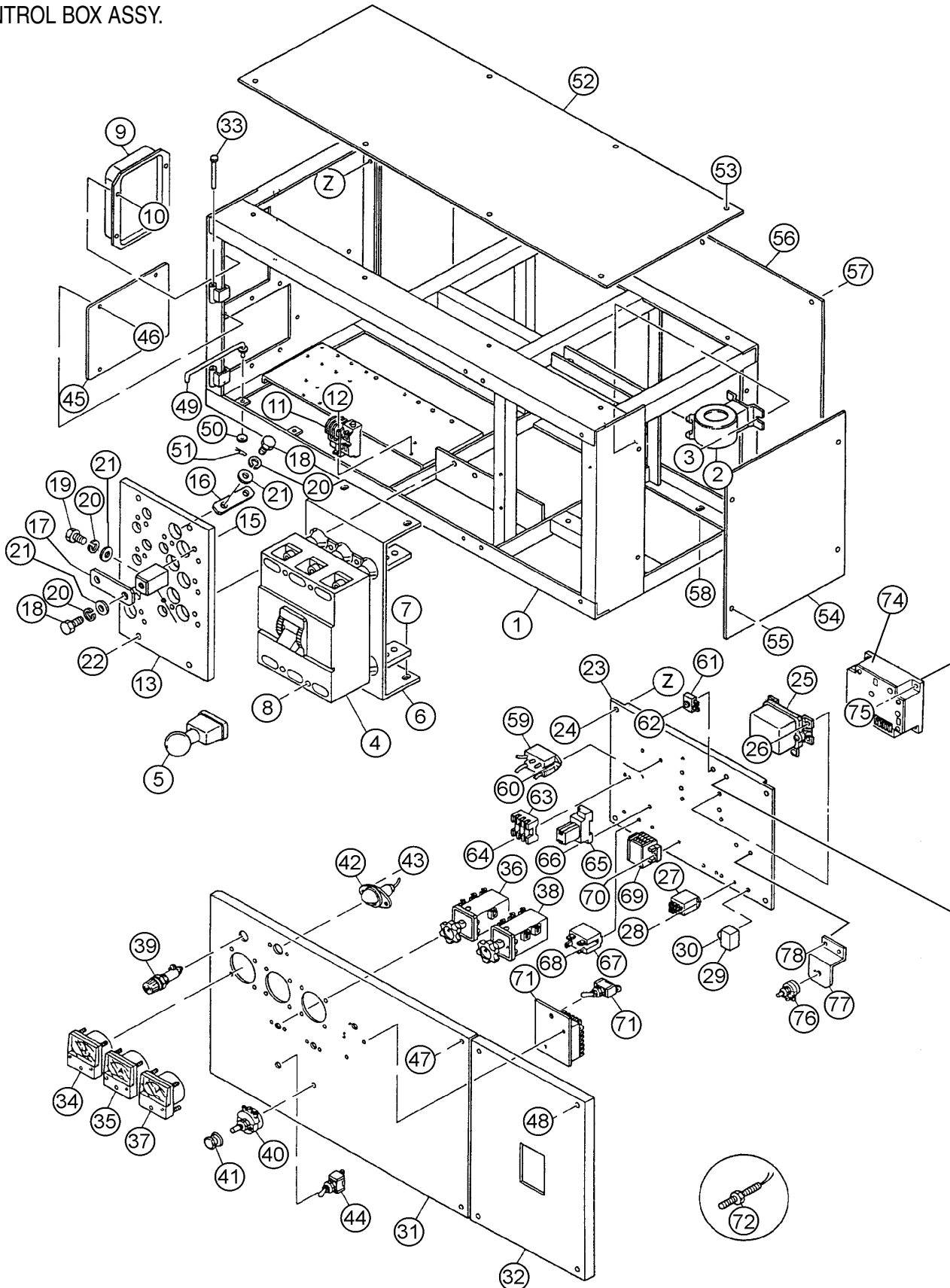
# DCA-300SSK GENERATOR ASSY.

## GENERATOR ASSY.(CONT)

<u>NO.</u>	<u>PART NO.</u>	<u>PART NAME</u>	<u>QTY.</u>	<u>REMARKS</u>
38	C3154400003	SUCTION COVER	1	
39	0017106016	HEX. HEAD BOLT	8	
40	0012112035	HEX. HEAD BOLT	16	
40	0042512000	LOCK WASHER	16	
41	C3132300003	COVER, FAN .....	1	S/N3691259 TO 3692208
41	C3132300014	COVER, FAN .....	1	S/N3692209~
42	0010106030	HEX. HEAD BOLT	1	
42	0041206000	PLAIN WASHER	1	
42	0600815000	NUT .....	1	S/N3692209~
43	0605000012	RUBBER SUSPENSION	2	
44	0030020000	HEX. NUT	4	
44	0040020000	LOCK WASHER	4	

# DCA-300SSK CONTROL BOX ASSY.

CONTROL BOX ASSY.



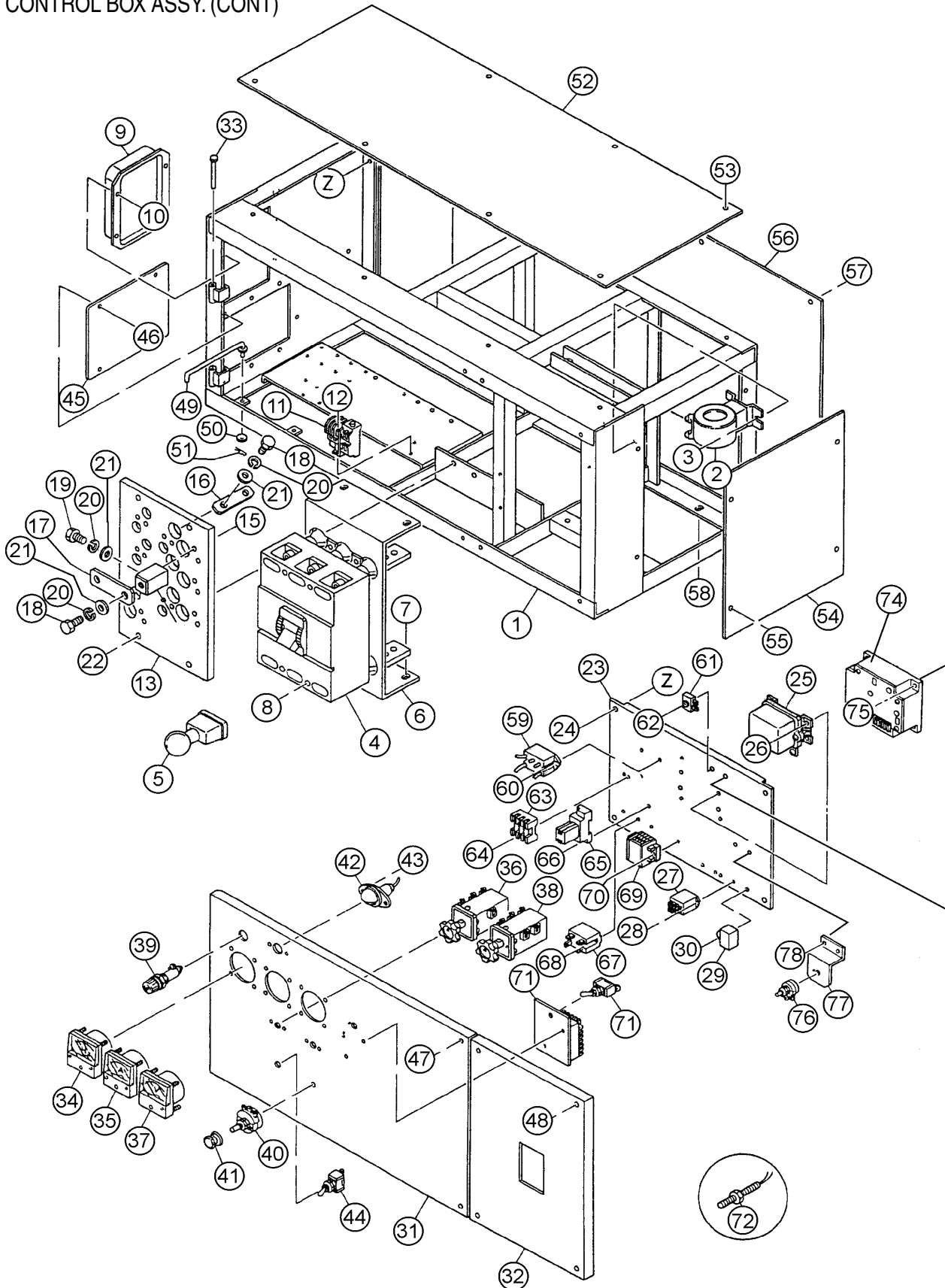
# DCA-300SSK CONTROL BOX ASSY.

## CONTROL BOX ASSY.

<u>NO.</u>	<u>PART NO.</u>	<u>PART NAME</u>	<u>QTY.</u>	<u>REMARKS</u>
1	C2214000102	CONTROL BOX .....	1 .....	S/N3691259 TO 3706720
1	C2214001502	CONTROL BOX .....	1 .....	S/N3706721~
2	0601806134	CURRENT TRANSFORMER .....	3 .....	CT-5MR500/5A
3	0027106016	MACHINE SCREW	6	
4	0601807373	CIRCUIT BREAKER,XS800NS800A .....	1 .....	UP TO 3706720
4	0601807513	CIRCUIT BREAKER, S6G800A .....	1 .....	S/N3706721~
5	0601802525	HANDLE, CIRCUIT BREAKER .....	1 .....	S/N3691259 TO 3706720
6	C2214600004	BRACKET, CIRCUIT BREAKER .....	2 .....	S/N3691259 TO 3706720
6	C2261600204	BRACKET, CIRCUIT BREAKER .....	1 .....	S/N3706721~
7	0017108020	HEX. HEAD BOLT	4	
8	0021008045	MACHINE SCREW	4	
8	0030008000	HEX. NUT .....	4 .....	S/N3691259 TO 3706720
8	0040008000	LOCK WASHER .....	4 .....	S/N3691259 TO 3706720
8	0041208000	PLAIN WASHER .....	4 .....	S/N3691259 TO 3706720
9	0601820625	AUTOMATIC VOLTAGE REGULATOR .....	1 .....	NTA-5A-2T
10	0027105016	MACHINE SCREW	4	
11	0601820892	OVER CURRENT RELAY .....	1 .....	TH-N20HZKP
12	0027104016	MACHINE SCREW	2	
13	C2274000103	CHANGE-OVER BOARD VOLTAGE	1	
14	8201852104	CHANGE TERMINAL	10	
15	0017108030	HEX. HEAD BOLT	20	
16	C2277200004	TERMINAL PLATE	3	
17	8201853104	CHANGE PLATE	6	
18	8201852504	HEX. HEAD BOLT	13	
19	0801830704	HEX. HEAD BOLT	13	
20	0040012000	LOCK WASHER	26	
21	0041412000	PLAIN WASHER	26	
22	0017110030	HEX. HEAD BOLT	4	
23	C2261500003	SET PANEL, ELECTRIC PARTS .....	1 .....	S/N 1337508 TO 3691258
23	C2261500013	SET PANEL, ELECTRIC PARTS .....	1 .....	S/N 3691259 TO 3696506
23	C2261500703	SET PANEL, ELECTRIC PARTS .....	1 .....	S/N3696507 TO 3701673
23	C2261500713	SET PANEL, ELECTRIC PARTS .....	1 .....	S/N3701674~
24	0017108020	HEX. HEAD BOLT .....	4	
25	6008151252	EMERGENCY RELAY .....	1 .....	S/N3696507 TO 3701673 REPLACES 0602200446
26	0017106016	HEX. HEAD BOLT .....	4 .....	S/N3696507 TO 3701673
27	0601824542	RELAY .....	2 .....	HH62SDC24V
28	0027103010	MACHINE SCREW .....	4	

# DCA-300SSK CONTROL BOX ASSY.

CONTROL BOX ASSY. (CONT)



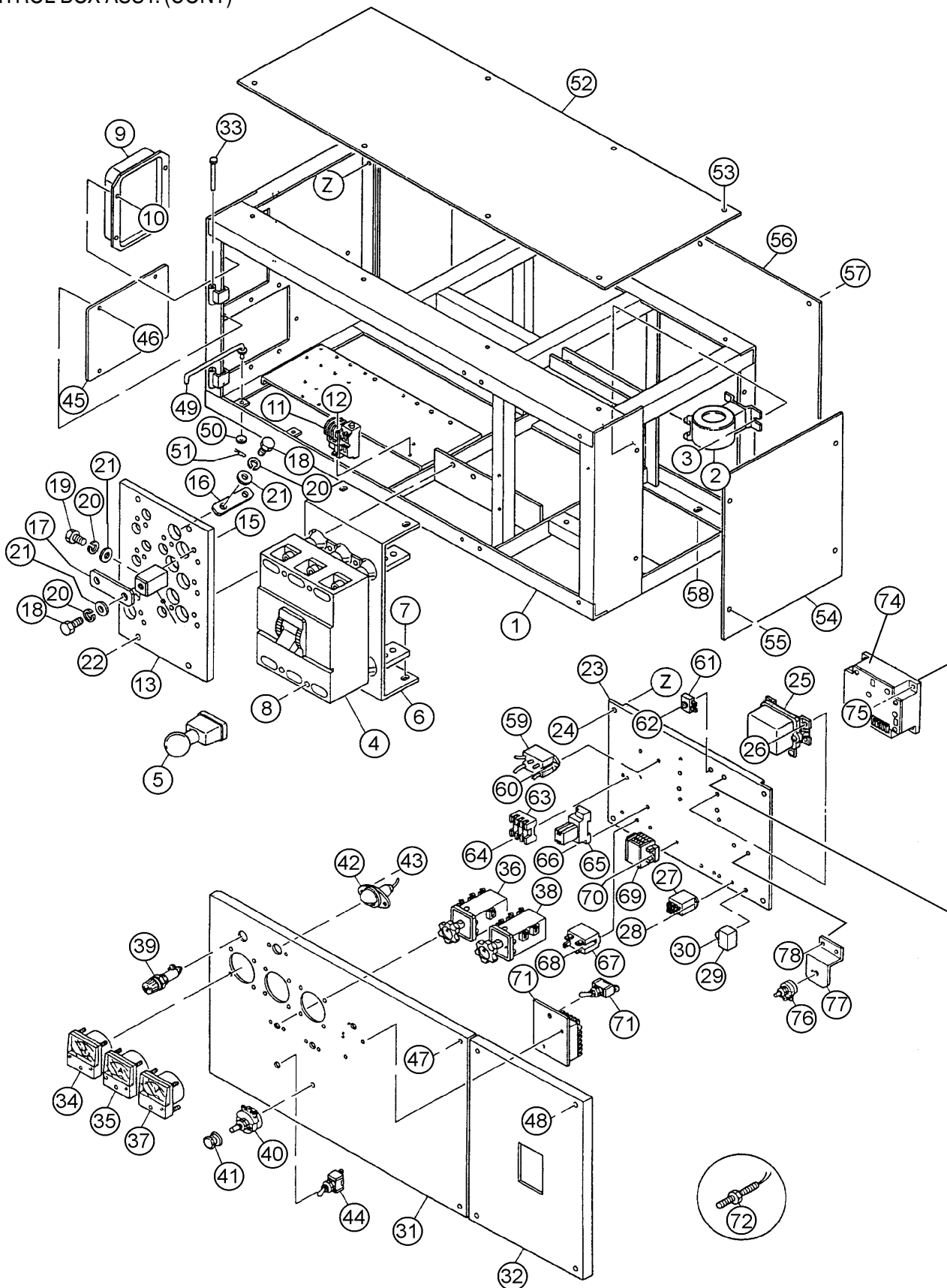
# DCA-300SSK CONTROL BOX ASSY.

## CONTROL BOX ASSY. (CONT)

<u>NO.</u>	<u>PART NO.</u>	<u>PART NAME</u>	<u>QTY.</u>	<u>REMARKS</u>
29	0602201911	UNIT, BATTERY SENSOR .....	1 .....	C7038A-00-00
30	0027106016	MACHINE SCREW	1	
31	C2224000503	CONTROL PANEL	1	
32	C2224000404	CONTROL PANEL .....	1 .....	S/N3691259 TO 3706720
32	C2224001504	CONTROL PANEL .....	1 .....	S/N3706721~
33	0605011211	PIN	2	
34	0601807622	FREQUENCY METER .....	1 .....	RSC-80F 220V 45-65HZ
35	0601806979	AC AMMETER .....	1 .....	RSS-80 0-500A 0-1000A
36	0601801040	CHANGE-OVER SWITCH, AMMETER .....	1 .....	SL-2AS
37	0601806887	AC VOLTMETER .....	1 .....	RSR-80 0-600V
38	0601801041	CHANGE-OVER SWITCH, VOLTMETER ...	1 .....	SL-2VS
39	0601810072	PILOT LAMP .....	1 .....	LP-132DC 220V
39	0601810261	BULB .....	1 .....	CT-13W
40	0601840073	RHEOSTAT (VOLTAGE REGULATOR) .....	1 .....	RA20A2SE102BJ 2W 1K OHM
41	0601840121	KNOB	1	
42	0601810161	PANEL LIGHT .....	1 .....	V325070
42	0601810214	BULB	1	
43	0207004000	HEX. NUT	2	
44	0601830710	SWITCH, PANEL LIGHT	1	
45	C2214600104	COVER .....	1 .....	S/N3691259 TO 3706720
46	0027105016	MACHINE SCREW .....	4 .....	S/N3691259 TO 3706720
47	C9221100004	HEX. HEAD BOLT	2	
47	0040008000	LOCK WASHER	2	
47	0041208000	PLAIN WASHER	2	
47	505015300	SNAP RING .....	2 .....	REPLACES 0080200007
48	0017108040	HEX. HEAD BOLT	4	
49	3871824004	STOPPER, CONTROL PANEL	1	
50	0041206000	PLAIN WASHER	1	
51	0605010502	SNAP PIN	1	
52	C2214500004	COVER, CONTROL BOX	1	
53	0017108020	HEX. HEAD BOLT	8	
54	C2214300004	SIDE PANEL, CONTROL BOX	1	
55	0017108020	HEX. HEAD BOLT	4	
56	C2214400004	PANEL, CONTROL BOX	1	
57	0017108020	HEX. HEAD BOLT	8	
58	0017110025	HEX. HEAD BOLT	4	
59	0601823861	ENGINE STOP UNIT, MSA9014 .....	1 .....	S/N3696507 TO 3701673
60	0027104015	MACHINE SCREW .....	2 .....	S/N3696507 TO 3701673

# DCA-300SSK CONTROL BOX ASSY.

## CONTROL BOX ASSY. (CONT)



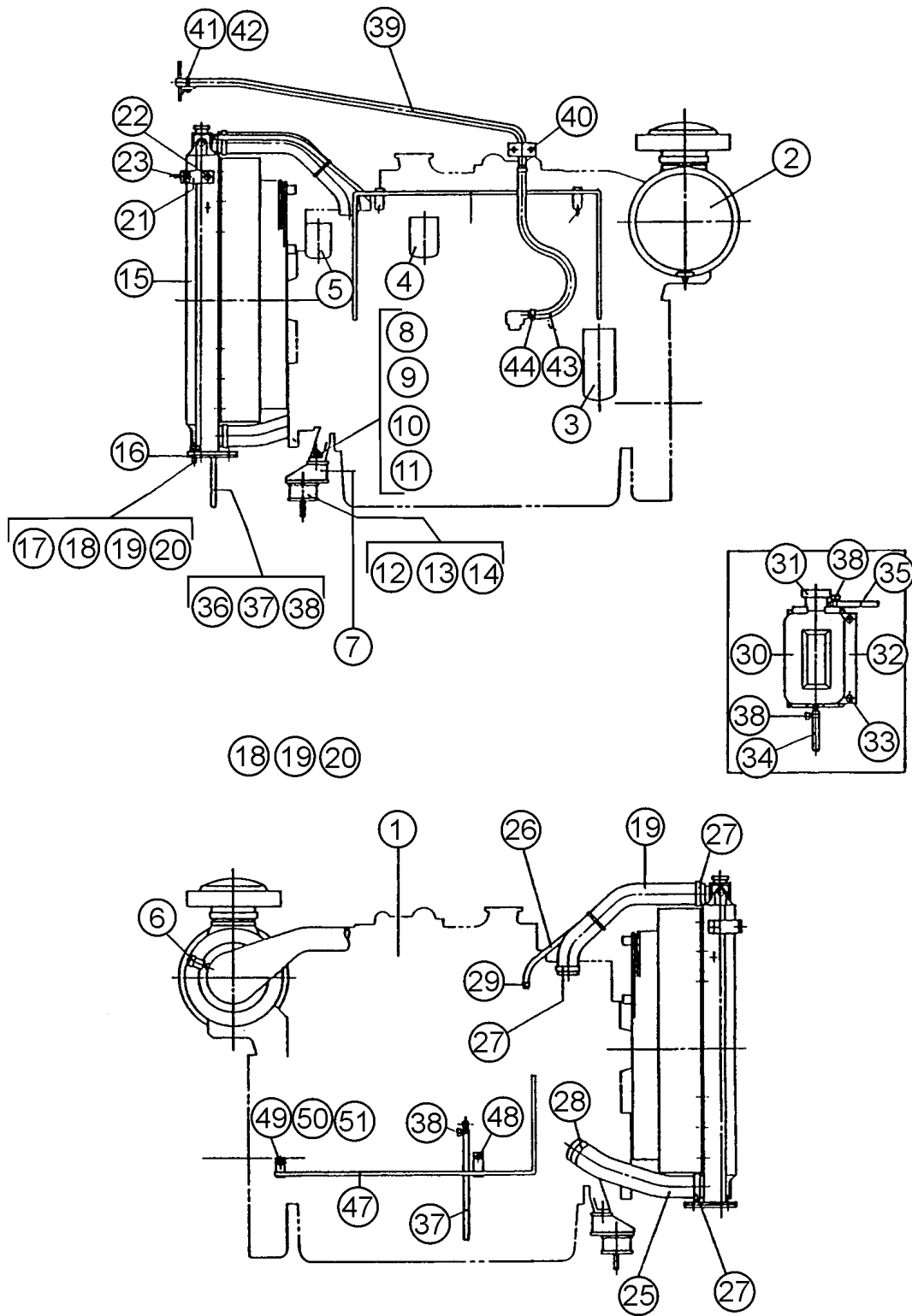
# DCA-300SSK CONTROL BOX ASSY.

## CONTROL BOX ASSY. (CONT)

<u>NO.</u>	<u>PART NO.</u>	<u>PART NAME</u>	<u>QTY.</u>	<u>REMARKS</u>
61	0601823240	RECTIFIER, DE4503 .....	4 .....	S/N3696507 TO 3701673
62	0021004030	MACHINE SCREW .....	2 .....	S/N3696507 TO 3701673
62	0040004000	LOCK WASHER .....	2 .....	S/N3696507 TO 3701673
62	0041204000	PLAIN WASHER .....	2 .....	S/N3696507 TO 3701673
63	0601802149	FUSE, 10A .....	1 .....	S/N3696507 TO 3701673
63	0601802149	FUSE (RIGHT), 10A .....	1 .....	S/N3701674~
63	0601806671	FUSE (LEFT), 15A .....	1 .....	S/N3701674~
63	0601802218	HOLDER, FUSE .....	1 .....	S/N3701674~
64	0027103020	MACHINE SCREW .....	2 .....	S/N3701674~
65	0601823732	RELAY .....	1 .....	S/N3696507 TO 3699681
65	0601827655	RELAY .....	1 .....	S/N3699682~
65	0601823109	SOCKET .....	1 .....	S/N3696507~
65	0601824400	HOLDER .....	1 .....	S/N3696507~
66	0027104020	MACHINE SCREW .....	2 .....	S/N3696507~
67	0601823706	RELAY, HE1ADC24V .....	1 .....	S/N3696507~
68	0027104015	MACHINE SCREW .....	2 .....	S/N3696507~
69	0601815402	TERMINAL BOARD, TS144P .....	1 .....	S/N3696507~
70	0027104020	MACHINE SCREW .....	2 .....	S/N3696507~
71	ECU9988N300/400	CONTROLLER .....	1 .....	REPLACES 0601827396 & 0602202545
72	0601831340	SWITCH, 82608DPDT .....	1 .....	S/N3696507 TO 3700240
72	0601830765	SWITCH, S303T .....	1 .....	S/N3700241~
73	DYNT11200	SPEED SENSOR .....	1 .....	S/N3696507~
73	0602202470	SEALED CABLE .....	1 .....	S/N3696507~
74	DYN110654000024	CONTROLLER .....	1 .....	S/N3701674~; REPLACES 0602202598
75	0027104020	MACHINE SCREW .....	4 .....	S/N3701674~
76	0601840009	RHEOSTAT, RA20A2SE5028 .....	1 .....	S/N3701674~
77	C3262600004	BRACKET .....	1 .....	S/N3701674~
78	0017106015	HEX. HEAD BOLT .....	2 .....	S/N3701674~

# DCA-300SSK ENGINE & RADIATOR ASSY. (UP TO S/N3697258)

ENGINE & RADIATOR ASSY. (UP TO S/N3697258)



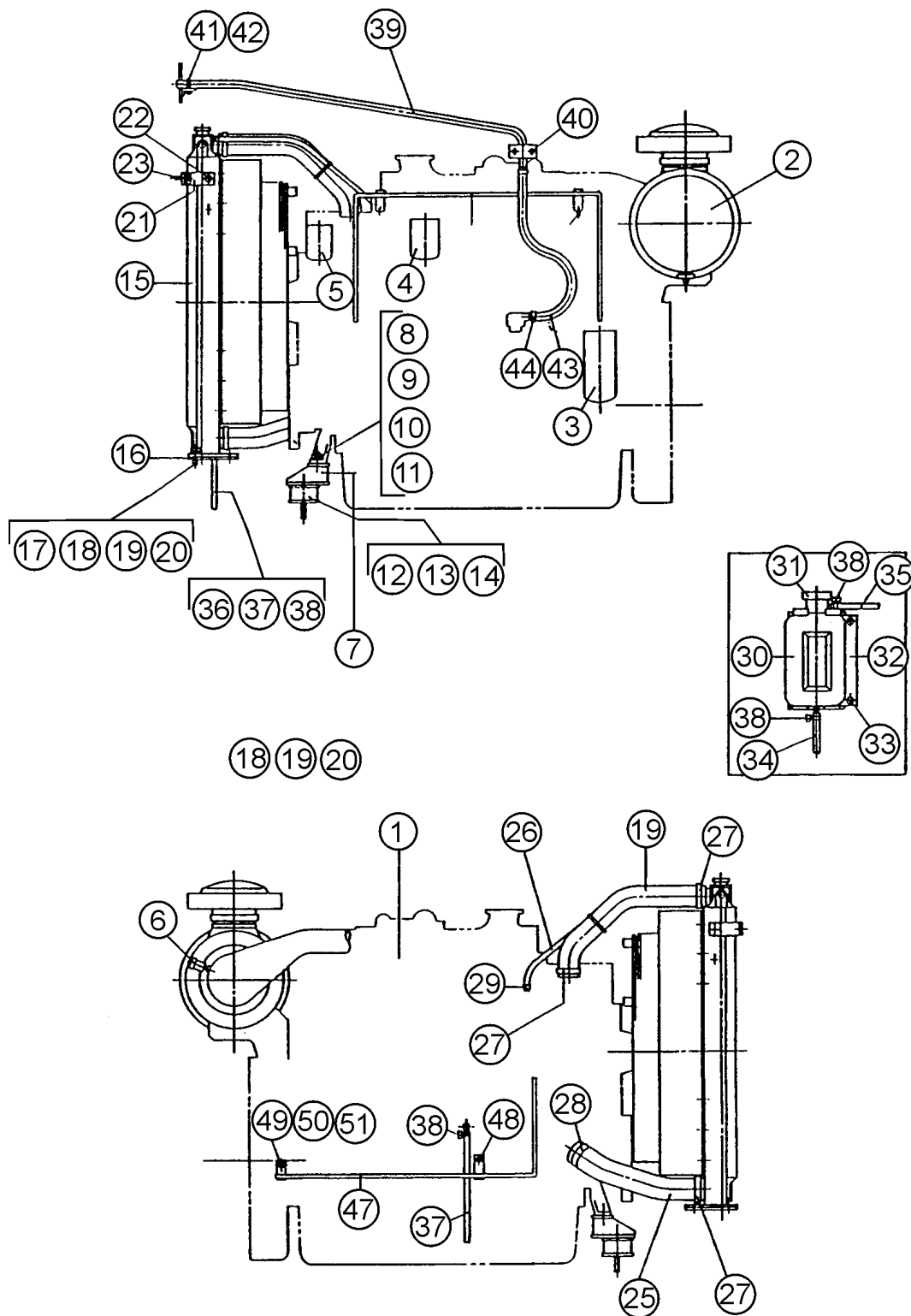
# DCA-300SSK ENGINE & RADIATOR ASSY. (UP TO S/N3697258)

ENGINE & RADIATOR ASSY. (UP TO S/N3691258)

<b>NO.</b>	<b>PART NO.</b>	<b>PART NAME</b>	<b>QTY.</b>	<b>REMARKS</b>
1	6155009100	ENGINE, KOMATSU SA6D 125E-2 .....	1 .....	S/N UP TO 3691258 REPLACES C2924200014
2	6125817032	ELEMENT, AIR CLEANER .....	1 .....	REPLACES 0602040156
3	6002111231	CARTRIDGE, OIL FILTER .....	1 .....	REPLACES 0602041146
4	6003118293	CARTRIDGE, FUEL FILTER .....	1 .....	REPLACES 0602042146
5	6004111151	CARTRIDGE, CORROSION RESISTOR .....	1 .....	REPLACES 0602045143
6	0602040678	DUST SENSOR .....	1 .....	REX01-8126
7	8185112004	ENGINE FOOT .....	1 .....	UP TO S/N 3691258
8	0010118060	HEX. HEAD BOLT .....	2 .....	UP TO S/N 3691258
9	0030018000	HEX. NUT .....	2 .....	UP TO S/N 3691258
10	0040018000	LOCK WASHER .....	2 .....	UP TO S/N 3691258
11	0041218000	PLAIN WASHER .....	4 .....	UP TO S/N 3691258
12	0605000011	RUBBER SUSPENSION	2	
13	0030016000	HEX. NUT	4	
14	0040016000	LOCK WASHER	4	
15	6152619720	RADIATOR .....	1 .....	REPLACES 0602011946
16	6152619170	RUBBER SHEET .....	2 .....	REPLACES 0605000490
17	0010012055	HEX. HEAD BOLT	4	
18	0030012000	HEX. NUT	4	
19	0040012000	LOCK WASHER	4	
20	0041212000	PLAIN WASHER	8	
21	8195123104	BRACKET, RADIATOR	2	
22	0017112025	HEX. HEAD BOLT	2	
23	0017110025	HEX. HEAD BOLT	2	
24	6152611520	RADIATOR HOSE .....	1 .....	REPLACES 0602014513
25	6152611531	RADIATOR HOSE .....	1 .....	REPLACES 0602014641
26	0726120911	RADIATOR HOSE .....	1 .....	REPLACES 0602014541
27	0728100809	HOSE BAND .....	6 .....	REPLACES 0602014067
28	0728100909	HOSE BAND .....	2 .....	REPLACES 0602014056
29	0728001920	HOSE BAND .....	2 .....	REPLACES 0602014058
30	0802081003C	RESERVE TANK .....	1 .....	REPLACES 0802081003
31	0802010900	CAP, RESERVE TANK .....	1 .....	REPLACES 0602010900
32	C231710003	BRACKET, RESERVE TANK	1	
33	0017108020	HEX. HEAD BOLT	2	
34	0199601800	HOSE	1	
35	0193601300	HOSE	1	
36	0193600500	HOSE	1	
37	0194100800	HOSE	1	
38	0605515170	HOSE BAND	5	
39	C2327100003	BREATHING PIPE	1	
40	0017108020	HEX. HEAD BOLT	2	

# DCA-300SSK ENGINE & RADIATOR ASSY. (UP TO S/N3697258)

ENGINE & RADIATOR ASSY. (UP TO S/N3697258)



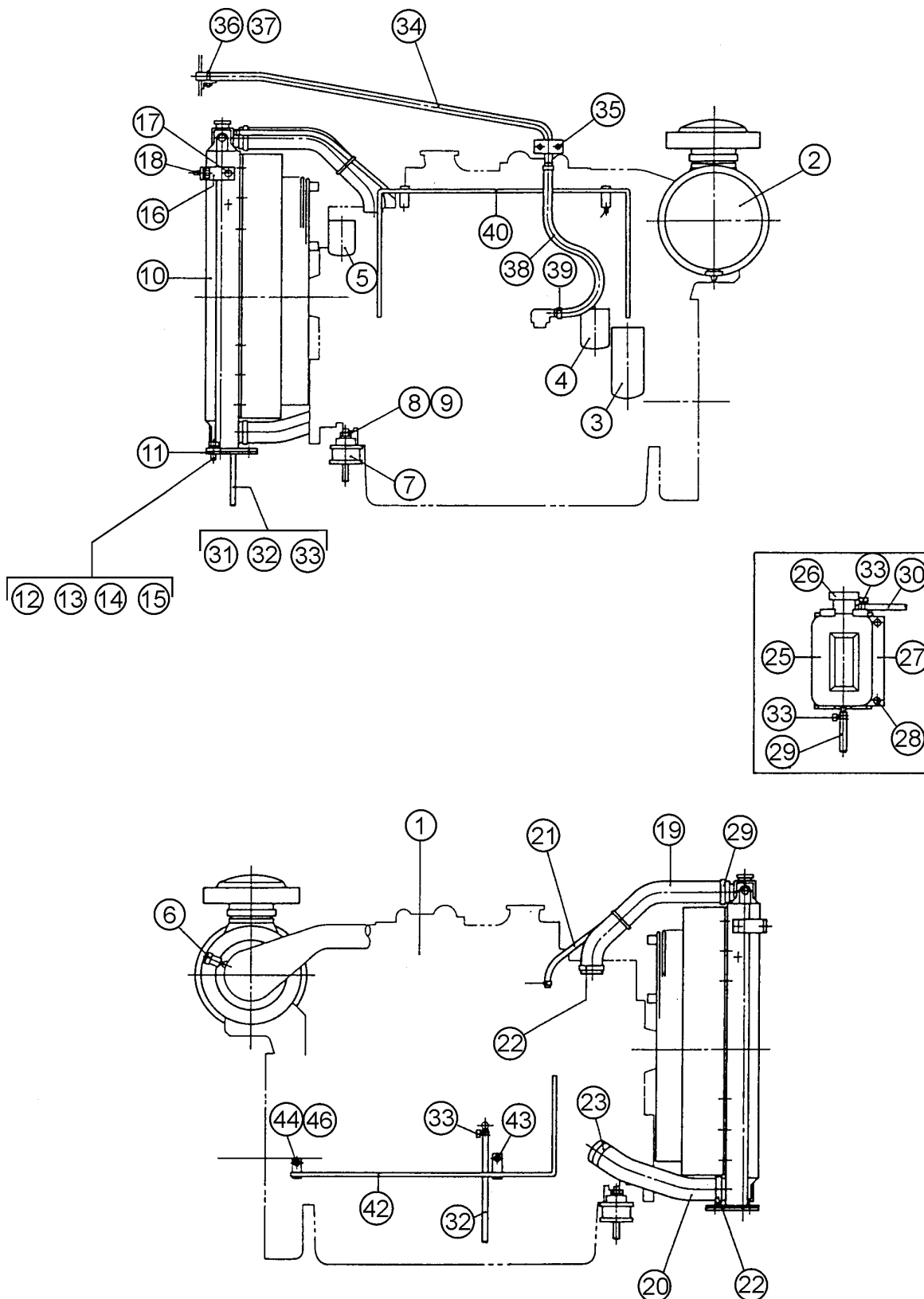
## DCA-300SSK ENGINE & RADIATOR ASSY. (UP TO S/N3697258)

ENGINE & RADIATOR ASSY. (UP TO S/N3697258)

<u>NO.</u>	<u>PART NO.</u>	<u>PART NAME</u>	<u>QTY.</u>	<u>REMARKS</u>
41	0603320112	U BOLT	1	
42	0038408000	HEX. NUT	2	
43	0268200700	HOSE	1	
44	0605515132	HOSE BAND	2	
45	C2358300103	CLAMPER ROD	1	
46	0017110020	HEX. HEAD BOLT	2	
47	C2358300003	CLAMPER ROD	1	
48	0017108020	HEX. HEAD BOLT	1	
49	0010016030	HEX. HEAD BOLT	1	
50	0040016000	LOCK WASHER	1	
51	0041216000	PLAIN WASHER	1	

# DCA-300SSK ENGINE & RADIATOR ASSY. (S/N 3708270 TO 3708296)

ENGINE & RADIATOR ASSY. (S/N3691259 TO S/N 3708296)



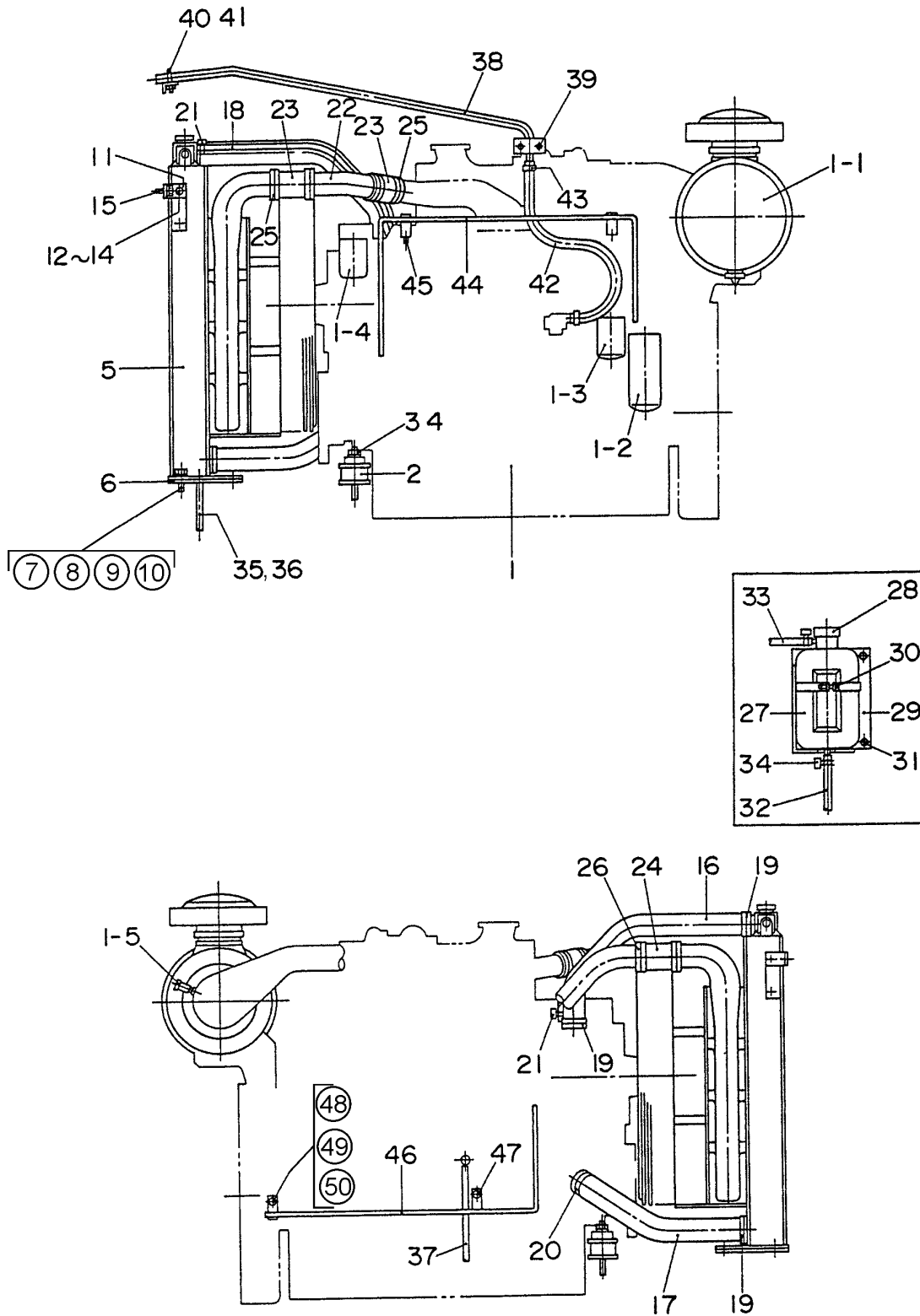
# DCA-300SSK ENGINE & RADIATOR ASSY. (S/N 3708270 TO 3708296)

ENGINE & RADIATOR ASSY. (S/N3691259 TO S/N 3708296)

<u>NO.</u>	<u>PART NO.</u>	<u>PART NAME</u>	<u>QTY.</u>	<u>REMARKS</u>
1	C2924200154	ENGINE .....	1	REPLACES S/N 3691259 TO 3701673
1	C2925200014	ENGINE .....	1	S/N3701674 TO 3708269
2	6125817032	ELEMENT, AIR CLEANER, INNER/OUTER	1	
3	6002111231	CARTRIDGE, OIL FILTER	1	
4	6003118321	CARTRIDGE, FUEL FILTER	1	
5	6004111151	CARTRIDGE, CORROSION RESISTOR	1	
6	0602040678	DUST SENSOR .....	1	REX018126
7	0605000011	RUBBER SUSPENSION .....	2	EA1012
8	0030016000	HEX. NUT	4	
9	0040016000	LOCK WASHER	4	
10	6152619720	RADIATOR .....	1	REPLACES 0602011946
11	615261970	RUBBER SHEET .....	2	REPLACES 0605000490
12	0010112055	HEX. HEAD BOLT	4	
13	0030012000	HEX. NUT	4	
14	0040012000	LOCK WASHER	4	
15	0041212000	PLAIN WASHER	8	
16	8195123104	BRACKET, RADIATOR	2	
17	0017112025	HEX. HEAD BOLT	2	
18	0017110025	HEX. HEAD BOLT	2	
19	0602014549	RADIATOR HOSE .....	1	REPLACES 6152611520
20	6152611531	RADIATOR HOSE .....	1	REPLACES 0602014641
21	0726120911	RADIATOR HOSE .....	1	REPLACES 0602014541
22	0728100809	HOSE BAND .....	6	REPLACES 0602014056
24	0728100197	HOSE BAND .....	2	REPLACES 0602014058
25	0802081003	RESERVE TANK	1	
26	0602010900	CAP, RESERVE TANK	1	
27	C2317100003	BRACKET, RESERVE TANK	1	
28	0017108020	HEX. HEAD BOLT	2	
29	0199901800	HOSE	1	
30	0193601300	HOSE	1	
31	0193600500	HOSE	1	
32	0194100800	HOSE	1	
33	0605515170	HOSE BAND	5	
34	C2327100003	BREATHER PIPE .....	1	S/N3691259 TO 3705209
34	C2327100012	BREATHER PIPE .....	1	S/N3705210 TO 3708269
35	0017108020	HEX. HEAD BOLT	2	
36	0603320112	U BOLT	1	
37	0207008000	HEX. NUT	2	
38	0268200700	HOSE	1	
39	0605515132	HOSE BAND	2	
40	C2358300103	CLAMPER ROD	1	
41	0017110020	HEX. HEAD BOLT	2	
42	C2358300003	CLAMPER ROD	1	
43	0017108020	HEX. HEAD BOLT	1	
44	0010016030	HEX. HEAD BOLT	1	
45	0040016000	LOCK WASHER	1	
46	0041216000	PLAIN WASHER	1	

# DCA-300SSK ENGINE & RADIATOR ASSY. (S/N 3708270 ~)

ENGINE & RADIATOR ASSY. (S/N 3708270~)



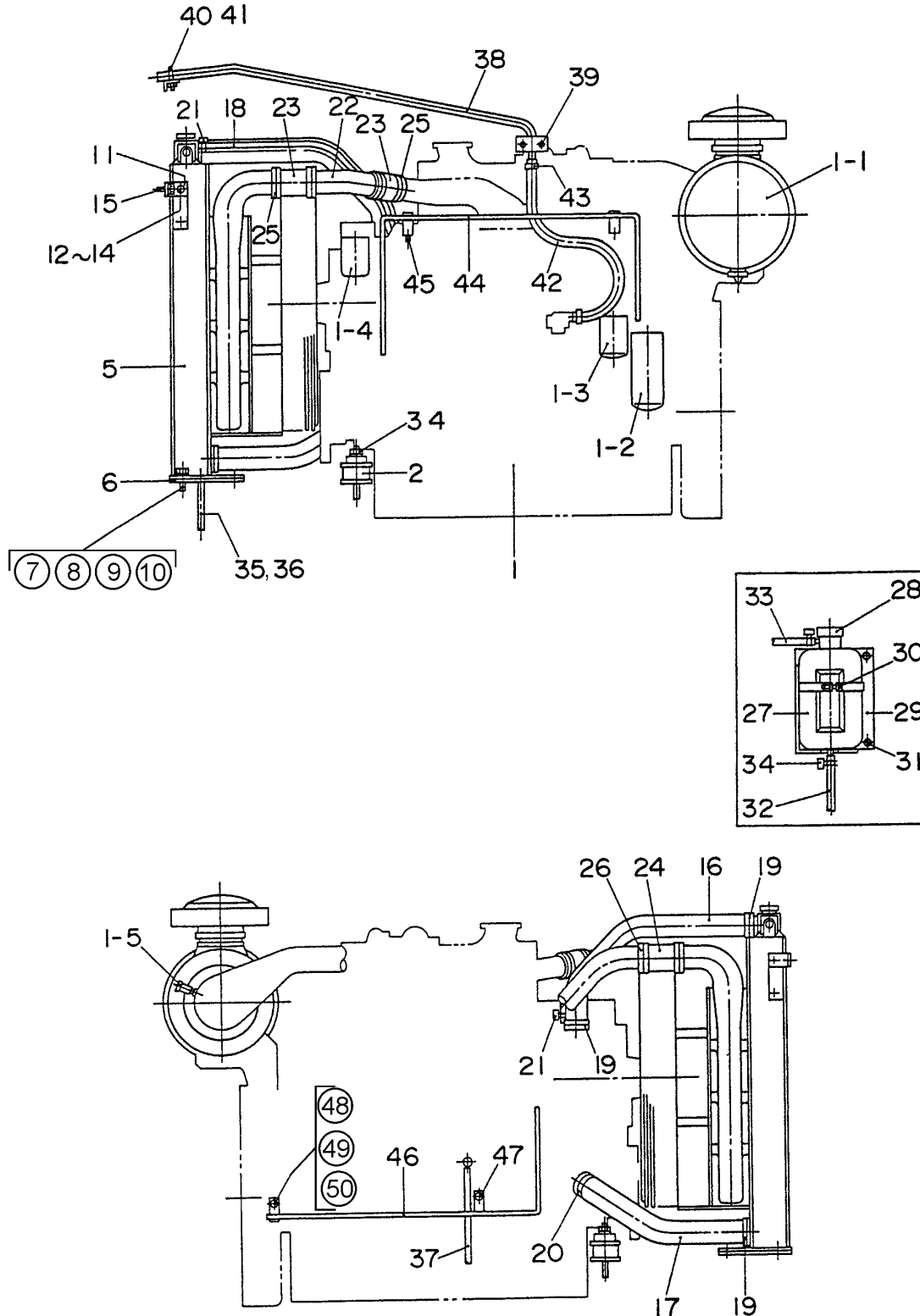
# DCA-300SSK ENGINE & RADIATOR ASSY. (S/N 3708270 ~)

ENGINE & RADIATOR ASSY. (S/N 3708270~)

<u>NO.</u>	<u>PART NO.</u>	<u>PART NAME</u>	<u>QTY.</u>	<u>REMARKS</u>
1	C2924200194	ENGINE .....	1	KOMATSU SAA6D125E-2
1-1	6125817032	ELEMENT, AIR CLEANER .....	1	REPLACES 06020 40145
1-2	6002111231	CARTRIDGE, OIL FILTER .....	1	REPLACES 06020 41146
1-3	6003118321	CARTRIDGE, FUEL FILTER .....	1	REPLACES 06020 42146
1-4	6004111151	CARTRIDGE, COROSION RESISTOR .....	1	REPLACES 06020 45143
1-5	0602040678	SENSOR, DUST REX01-8126	1	
2	0605000011	SUSPENSION, RUBBER EA1012	2	
3	0030016000	NUT, HEX	4	
4	0040016000	WASHER, SPRING	4	
5	6152629101	RADIATOR .....	1	REPLACES 06020 12706
6	6995619230	SHEET, RUBBER .....	2	REPLACES 06050 00085
7	0010120070	BOLT, HEX HEAD	4	
8	0030020000	NUT, HEX	8	
9	004002000	WASHER, SPRING	4	
10	0041220000	WASHER, PLAIN	8	
11	C2311100504	BRACKET, RADIATOR	2	
12	0010112025	BOLT, HEX HEAD	2	
13	0040012000	WASHER, SPRING	2	
14	0041212000	WASHER, PLAIN	2	
15	0017110025	BOLT, HEX HEAD	2	
16	6152611530	HOSE, RADIATOR .....	1	REPLACES 06020 14539
17	6125621540	HOSE, RADIATOR .....	1	REPLACES 06020 14653
18	0726120911	HOSE, RADIATOR .....	1	REPLACES 06020 14541
19	0728100809	HOSE BAND .....	6	REPLACES 06020 14067
20	0728100909	HOSE BAND .....	2	REPLACES 06020 14056
21	0728100197	HOSE BAND .....	2	REPLACES 06020 14058
22	6152124380	PIPE, RADIATOR .....	1	REPLACES 06020 13257
23	6152124410	HOSE, RADIATOR .....	2	REPLACES 06020 14578
24	6152124420	HOSE, RADIATOR .....	1	REPLACES 06020 14579
25	0602014900	HOSE BAND .....	8	REPLACES 06020 14900
26	6152124490	HOSE BAND .....	4	REPLACES 06020 14901
27	0802081003	TANK, RESERVE	1	
28	0602010900	CAP, RESERVE TANK	1	
29	C2317100304	BRACKET, RESERVE TANK	1	
29	02292 00550	CUSHION, RUBBER	1	

# DCA-300SSK ENGINE & RADIATOR ASSY. (S/N 3708270 ~)

ENGINE & RADIATOR ASSY. (S/N 3708270~)



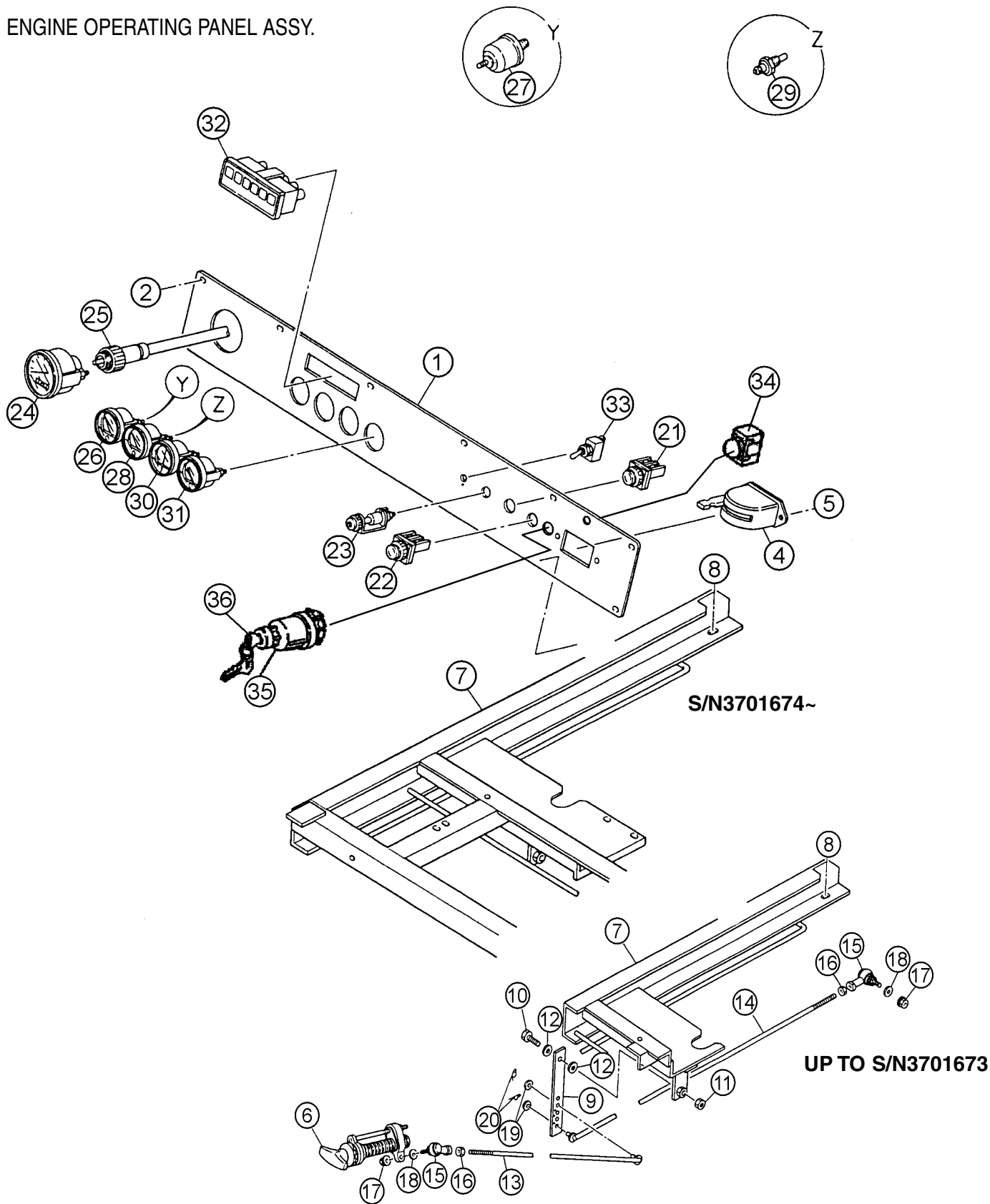
# DCA-300SSK ENGINE & RADIATOR ASSY. (S/N 3708270 ~)

ENGINE & RADIATOR ASSY. (S/N 3708270~)

<u>NO.</u>	<u>PART NO.</u>	<u>PART NAME</u>	<u>QTY.</u>	<u>REMARKS</u>
30	00171 06025	BOLT, HEX HEAD	1	
31	00171 08020	BOLT, HEX HEAD	2	
32	01999 01900	HOSE	1	
33	01936 02000	HOSE	1	
34	06055 15170	HOSE BAND	2	
35	01936 00560	HOSE	1	
36	06055 15170	HOSE BAND	1	
37	02691 00650	HOSE	1	
38	C23271 00103	PIPE, BREATHER	1	
39	00171 08020	BOLT, HEX HEAD	2	
40	06033 20112	UBOLT	1	
41	02070 08000	NUT, HEX HEAD	2	
42	02682 00700	HOSE	1	
43	06055 15132	HOSE BAND	2	
44	C23583 01003	ROD, CLAMPER	1	
45	00171 10020	BOLT, HEX HEAD	2	
46	C23583 00003	ROD, CLAMPER	1	
47	00171 08020	BOLT, HEX HEAD	1	
48	00100 16030	BOLT, HEX HEAD	1	
49	00400 16000	WASHER, SPRING	1	
50	00412 16000	WASHER, PLAIN	1	

# DCA-300SSK ENGINE OPERATING PANEL ASSY.

ENGINE OPERATING PANEL ASSY.



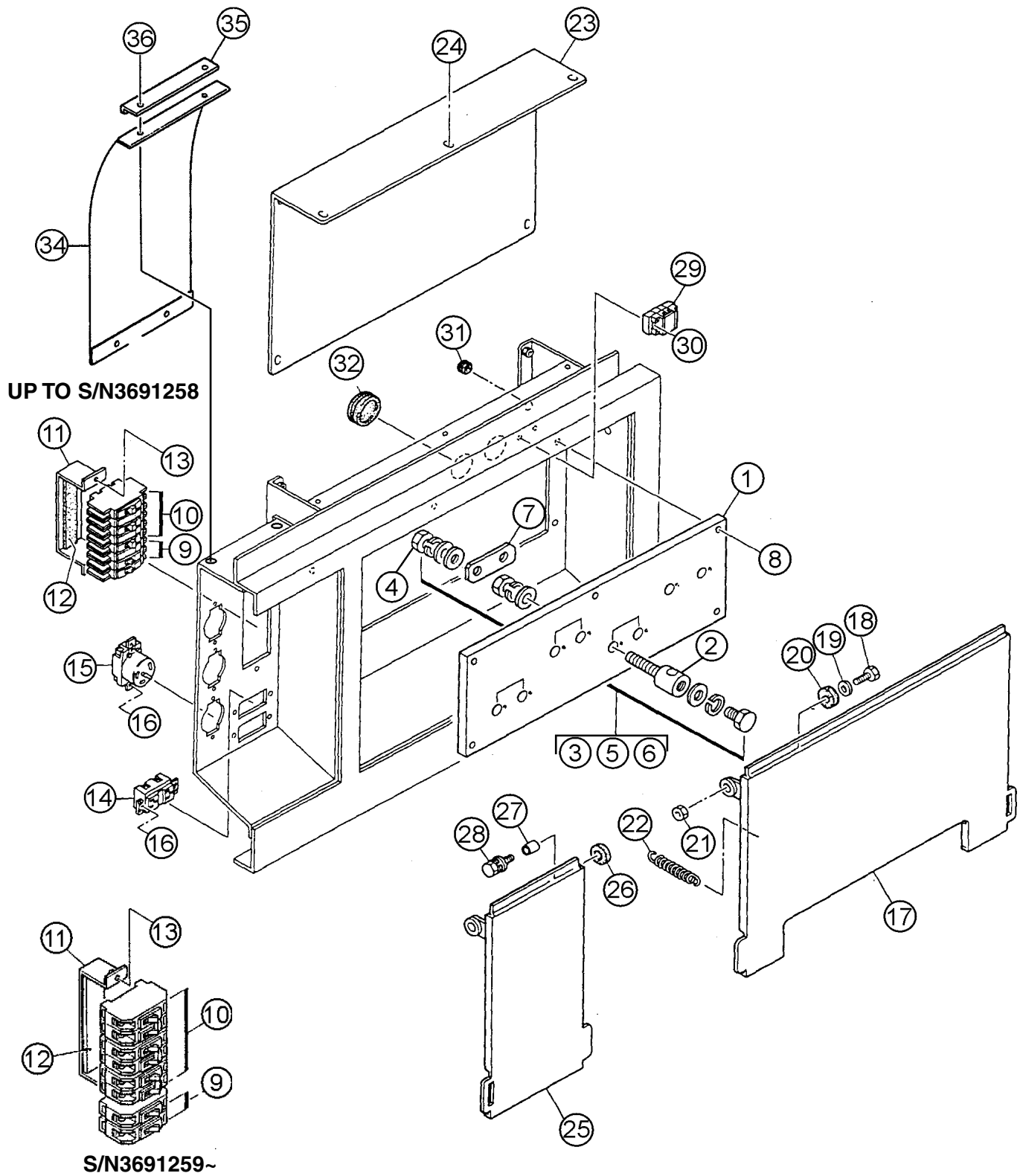
# DCA-300SSK ENGINE OPERATING PANEL ASSY.

## ENGINE OPERATING PANEL ASSY.

<u>NO.</u>	<u>PART NO.</u>	<u>PART NAME</u>	<u>QTY.</u>	<u>REMARKS</u>
1	C2352100203	OPERATING PANEL .....	1	UP TO S/N3696506
1	C2352100213	OPERATING PANEL .....	1	S/N3696507 TO 3701673
1	C2352100223	OPERATING PANEL .....	1	S/N3701674~
2	0017106016	HEX. HEAD BOLT .....	8	UP TO S/N3701673
2	0017106015	HEX. HEAD BOLT .....	8	S/N3701674~
3	0207006000	HEX. NUT	4	
4	0602101000	BATTERY SWITCH	1	
5	0021008080	MACHINE SCREW	2	
5	0030008000	HEX. NUT	2	
5	0040008000	LOCK WASHER	2	
5	0041208000	PLAIN WASHER	2	
6	0800250300	THROTTLE HANDLE .....	1	UP TO S/N3701673
7	C2484000003	SET FRAME .....	1	S/N 3701674 TO 3708296
7	C2484000303	SET FRAME .....	1	S/N 3708297
8	0017110025	HEX. HEAD BOLT	2	
9	8192183004	LINK, GOVERNOR ROD .....	1	UP TO S/N3701673
10	0010010035	HEX. HEAD BOLT .....	1	UP TO S/N3701673
11	0030010000	HEX. NUT .....	1	UP TO S/N3701673
12	0041210000	PLAIN WASHER .....	2	UP TO S/N3701673
13	C2355300404	GOVERNOR ROD .....	1	S/N 1337508 TO 3691258
13	C2355300414	GOVERNOR ROD .....	1	S/N 3691259 TO 3701673
14	C2355300104	GOVERNOR ROD .....	1	UP TO S/N3701673
15	0602180106	BALL JOINT .....	2	UP TO S/N3701673
16	0030008000	HEX. NUT .....	2	UP TO S/N3701673
17	0207006000	HEX. NUT .....	2	UP TO S/N3701673
18	0041206000	PLAIN WASHER .....	2	UP TO S/N3701673
19	0041206000	PLAIN WASHER .....	2	UP TO S/N3701673
20	505015300	SNAP PIN .....	2	UP TO S/N3701673; REPLACES 0605010502
21	0601830448	PREHEAT BUTTON, AH25FB10 .....	1	S/N3696507~
22	0601831557	EMERGENCY STOP BUTTON .....	1	S/N3701674~; AR22V2R01R
23	6008153730	PREHEAT LAMP .....	1	REPLACES 0602102055
24	0602120054	TACHOMETER .....	1	25000-KX4110
25	0602120156	CABLE, TACHOMETER .....	1	62500-KA4210L=3000
26	0602122060	OIL PRESSURE GAUGE .....	1	42000-KX1410
27	0602122200	UNIT, OIL PRESSURE .....	1	53000-AC0101
28	0602123061	WATER TEMPERATURE GAUGE .....	1	40000-KX0910
29	0602123206	UNIT, WATER TEMPERATURE .....	1	51400-KS0600
30	0602121052	CHARGING AMMETER .....	1	43000-KV0300
31	0602125060	FUEL GAUGE .....	1	41000-KW0110
32	0602115014	MONITOR .....	1	V337660-0000
33	0601830710	ENGINE SPEED SWITCH, S301T ...	1	S/N3701674~
34	0806410000	STOP BUTTON .....	1	UP TO S/N3701673; REPLACES 0602104045
35	6008155390	STARTER SWITCH .....	1	UP TO S/N3701673; REPLACES 0602100049
36	615	KEY, STARTER SWITCH .....	1	UP TO S/N3701673; REPLACES 0602104045

# DCA-300SSK OUTPUT TERMINAL ASSY.

OUTPUT TERMINAL ASSY.



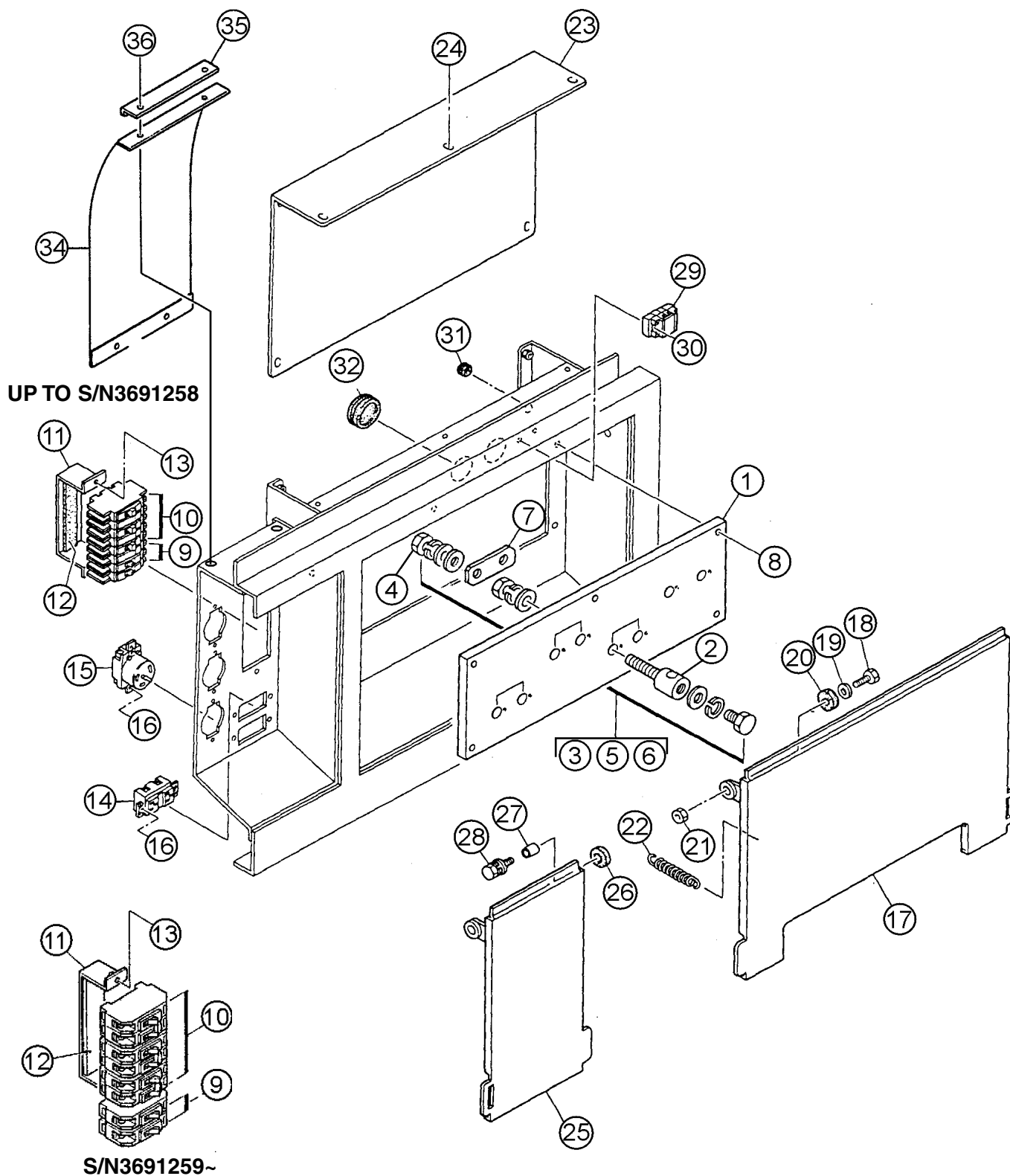
# DCA-300SSK OUTPUT TERMINAL ASSY.

## OUTPUT TERMINAL ASSY.

<u>NO.</u>	<u>PART NO.</u>	<u>PART NAME</u>	<u>QTY.</u>	<u>REMARKS</u>
1	C2231700203	SET BOARD, OUTPUT TERMINAL .....	1 .....	UP TO S/N 3708296
1	8221860203	SET BOARD, OUTPUT TERMINAL .....	1 .....	UP TO S/N 3708297~
2	0801830404	OUTPUT TERMINAL	8	
3	0801830904	HEX. HEAD BOLT	8	
4	0039320000	HEX. NUT	16	
5	0040020000	LOCK WASHER	24	
6	0041420000	PLAIN WASHER	32	
7	3501860604	TERMINAL PLATE	3	
8	0019108040	HEX. HEAD BOLT .....	5 .....	UP TO S/N 3708296
8	0042308000	LOCK WASHER .....	5 .....	UP TO S/N 3708296
8	0042408000	PLAIN WASHER .....	5 .....	UP TO S/N 3708296
8	0019110050	BOLT, HEX HEAD .....	5 .....	S/N 3708297~
8	004231000	WASHER SPRING .....	5 .....	S/N 3708297~
8	004241000	WASHER PLAIN .....	5 .....	S/N 3708297~
9	0601804887	CIRCUIT BREAKER, KM-51 265V 20A .....	2 .....	S/N3691259 TO 3706720
9	0601808803	CIRCUIT BREAKER, QOU120B 20A .....	2 .....	S/N3706721~; REPL. 0601805313
10	0601805840	CIRCUIT BREAKER, KM-52 265V 50A .....	3 .....	S/N3691259 TO 3706720
10	0601808804	CIRCUIT BREAKER, QOU250B 50A .....	3 .....	S/N3706721~
11	C1261600204	BRACKET, CIRCUIT BREAKER .....	1 .....	S/N3691259 TO 3706720
11	C3261600704	BRACKET, CIRCUIT BREAKER .....	1 .....	S/N3706721~
12	0223300200	RUBBER CUSHION .....	1 .....	S/N3691259 TO 3706720
12	0221200150	RUBBER CUSHION .....	1 .....	S/N3706721~
13	0017106020	HEX. HEAD BOLT	2	
14	0601812597	RECEPTACLE, 125 V, 20 AMP .....	2 .....	S/N 1337508 TO 3691258
14	0601812598	RECEPTACLE, 125 V, 20 AMP .....	2 .....	S/N 3691259~
15	0601811034	RECEPTACLE .....	3 .....	REPLACES 0601812565
16	0027104015	MACHINE SCREW	10	
16	0030004000	HEX. NUT	10	
16	0041204000	PLAIN WASHER	10	
17	C2237100403	COVER, OUTPUT TERMINAL .....	1 .....	S/N 1337508 TO 3691258
17	C2237101103	COVER, OUTPUT TERMINAL .....	1 .....	S/N 3691259~
17	C2237101103	COVER, OUTPUT TERMINAL .....	1 .....	S/N 3708297~
18	0019112045	HEX. HEAD BOLT	2	
19	0042412000	PLAIN WASHER	2	
20	0805009804	RUBBER WASHER	2	
20	0805015604	RUBBER WASHER .....	2 .....	S/N 3708297~

# DCA-300SSK OUTPUT TERMINAL ASSY.

OUTPUT TERMINAL ASSY.



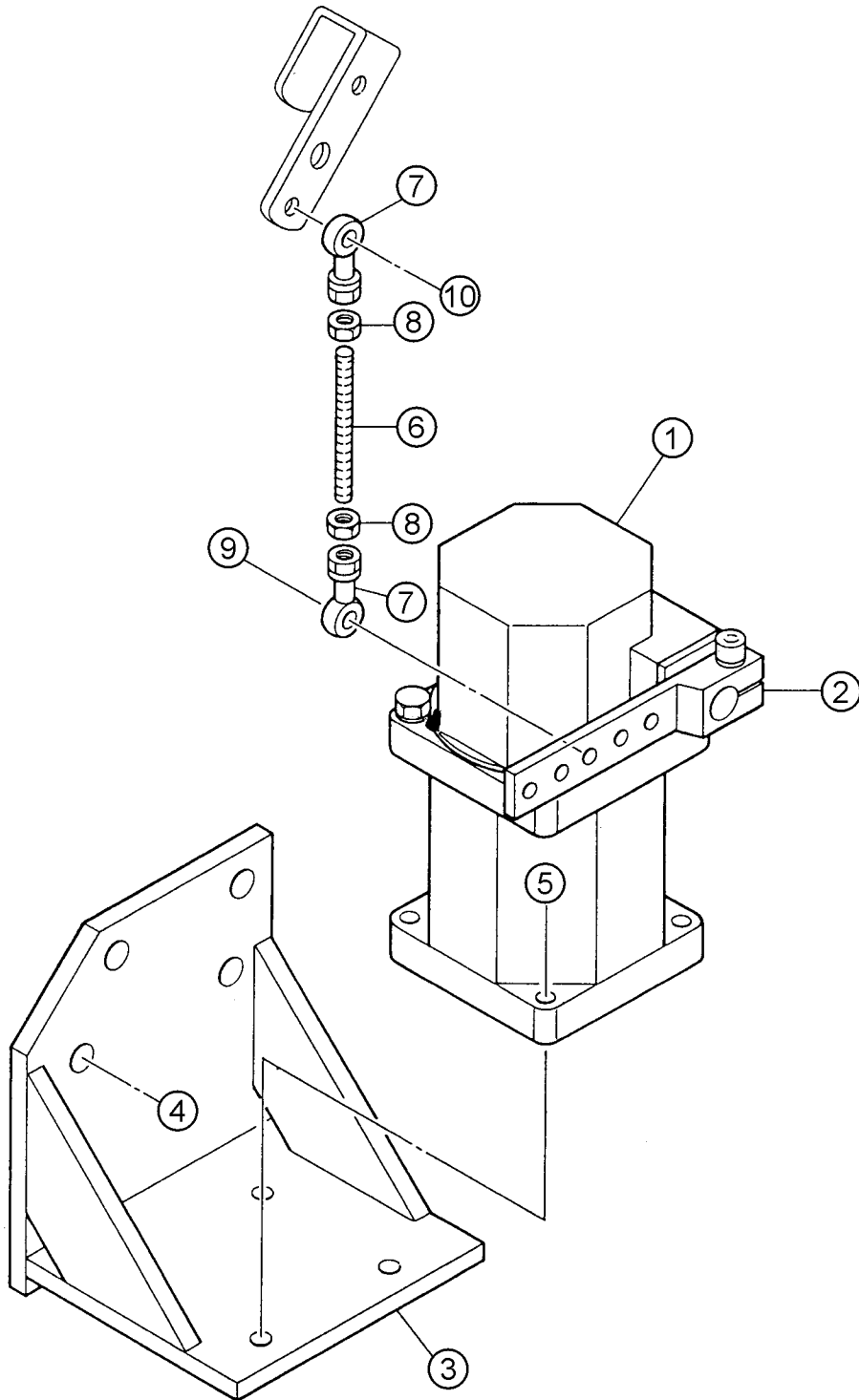
# DCA-300SSK OUTPUTTERMINAL ASSY.

## OUTPUT TERMINAL ASSY.

<u>NO.</u>	<u>PART NO.</u>	<u>PART NAME</u>	<u>QTY.</u>	<u>REMARKS</u>
21	020501200	HEX. NUT	2	
22	0845043704	SPRING	2	
23	C2237100504	COVER .....	1	S/N 1337508 TO 3691258
23	C2237100514	COVER .....	1	S/N 3691259~
23	C2237101204	COVER .....	1	S/N 3708297~
24	0017108020	HEX. HEAD BOLT	9	
25	C0237101504	COVER, OUTPUT TERMINAL .....	1	S/N 3691259~
26	0805015604	RUBBER WASHER .....	1	S/N 3691259~
27	0845054204	COLLER .....	2	S/N 3691259~
28	0017110040	HEX. HEAD BOLT .....	2	S/N 3691259~
29	0601815324	TERMINAL BOARD, TS22P .....	1	S/N3696507~
30	0027104020	MACHINE SCREW .....	2	S/N3696507~
31	0601850275	GROMMET .....	1	S/N3696507
32	0601851780	GROMMET .....	2	S/N3700674~
34	C2237101504	COVER .....	1	S/N 3708297~
35	C2237400104	BRACKET	1	
36	0017106020	BOLT, HEX HEAD .....	2	S/N 3708297~

# DCA-300 SSK ACTUATOR ASSY.

ACTUATOR ASSY. (S/N3701674~)



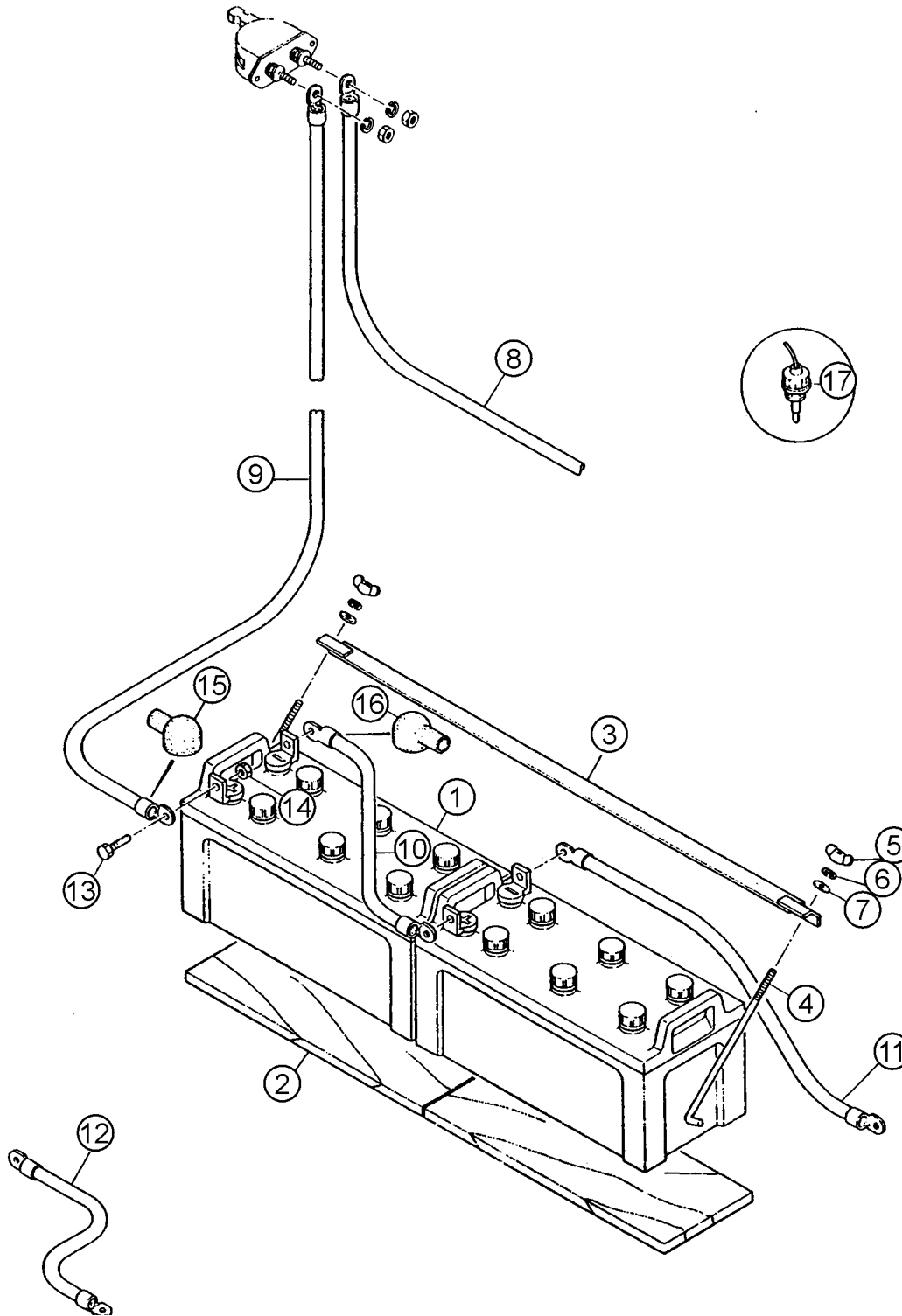
# DCA-300 SSK ACTUATOR ASSY.

ACTUATOR ASSY. (S/N 3701674~)

<u>NO.</u>	<u>PART NO.</u>	<u>PART NAME</u>	<u>QTY.</u>	<u>REMARKS</u>
1	DYNC110240000024	ACTUATOR .....	1 .....	REPLACES 0602150091
2	DYNC182	LEVER .....	1 .....	REPLACES 0602211090
3	C1356200004	BRACKET, ACTUATOR	1	
4	0012310030	HEX. HEAD BOLT	4	
5	0010306035	HEX. HEAD BOLT	4	
5	0207006000	HEX. NUT	4	
5	0040006000	LOCK WASHER	4	
5	0041206000	PLAIN WASHER	4	
6	0602211091	ROD	1	
7	0602180190	BALL JOINT	2	
8	0602211092	HEX. NUT	2	
9	0010106025	HEX. HEAD BOLT	1	
9	0207006000	HEX. NUT	1	
9	0041206000	PLAIN WASHER	1	
10	0010106025	HEX.HEAD BOLT	1	
10	0207006000	HEX. NUT	1	
10	0041206000	PLAIN WASHER	4	

# DCA-300 SSK BATTERY ASSY.

BATTERY ASSY.



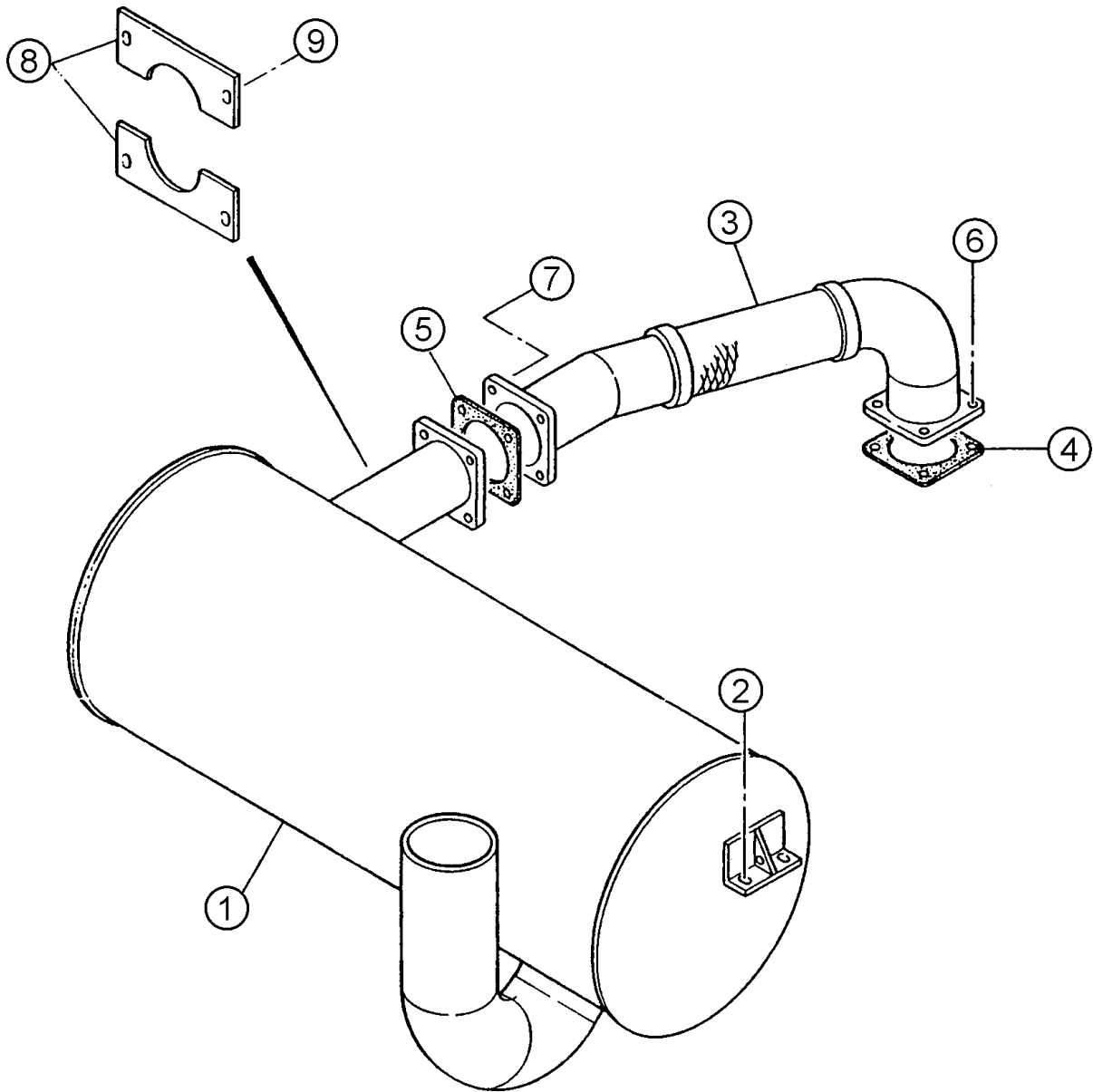
# DCA-300 SSK BATTERY ASSY.

## BATTERY ASSY.

<u>NO.</u>	<u>PART NO.</u>	<u>PART NAME</u>	<u>QTY.</u>	<u>REMARKS</u>
1	0168614551	BATTERY	2	
2	0805000804	BATTERY SHEET	2	
3	3972250004	BATTERY BAND	1	
4	0805002904	BATTERY BOLT	2	
5	0037808000	WING NUT	2	
6	0040008000	LOCK WASHER	2	
7	0041208000	PLAIN WASHER	2	
8	C2347600404	BATTERY CABLE	1	
9	C2347600104	BATTERY CABLE	1	
10	C2347600204	BATTERY CABLE	1	
11	C2347600304	BATTERY CABLE	1	
12	C2347200004	EARTH CABLE	1	
13	0010010030	HEX. HEAD BOLT	4	
14	0030010000	HEX. NUT	4	
15	0845040414	TERMINAL CAP +	2	
16	0845041304	TERMINAL CAP -	2	
17	0602220204	BATTERY SENSOR	1	

# DCA-300SSK MUFFLER ASSY.

MUFFLER ASSY.



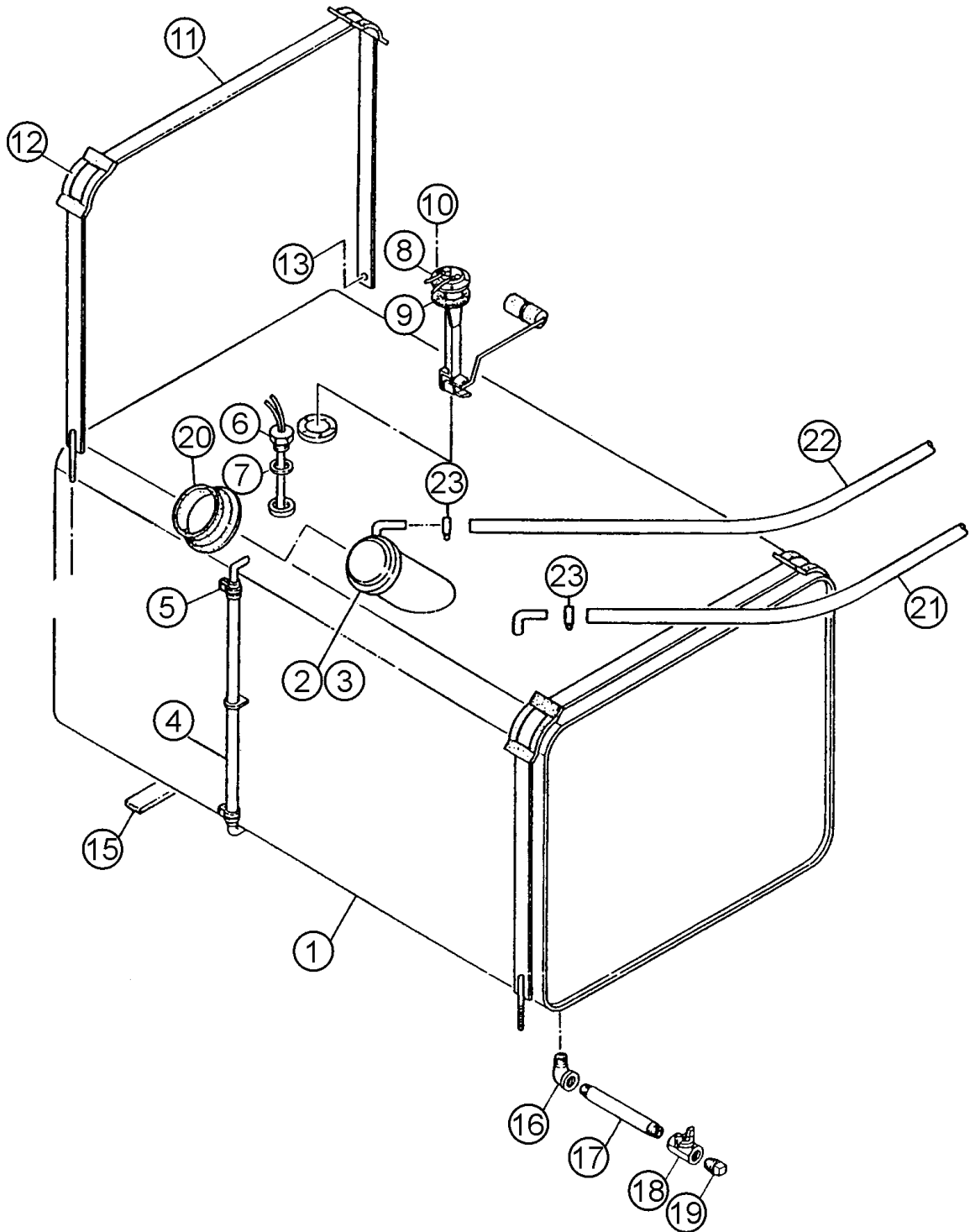
# DCA-300SSK MUFFLER ASSY.

## MUFFLER ASSY.

<u>NO.</u>	<u>PART NO.</u>	<u>PART NAME</u>	<u>QTY.</u>	<u>REMARKS</u>
1	C2331100002	MUFFLER	1	
2	0019210025	HEX. HEAD BOLT	4	
3	C2334000003	EXHAUST PIPE .....	1	UP TO S/N 3708296
3	C2234000503	EXHAUST PIPE .....	1	S/N 3708297~
4	6150115751	GASKET .....	1	REPLACES 0602320142
5	7502356004	GASKET .....	1	S/N 1337508 TO 3691258
5	C1334200304	GASKET .....	1	S/N 3691259 TO S/N 3708296
5	6150115751	GASKET .....	1	S/N 3708297~
6	0010312050	HEX. HEAD BOLT	4	
6	0030312000	HEX. NUT	4	
6	0040012000	LOCK WASHER	4	
6	0041212000	PLAIN WASHER	8	
7	0010112055	HEX. HEAD BOLT	4	
7	0030012000	HEX. NUT	4	
7	0040012000	LOCK WASHER	4	
7	0041212000	PLAIN WASHER	8	
8	C2331300004	COVER	2	
9	0017108020	HEX. HEAD BOLT	4	

# DCA-300SSK FUEL TANK ASSY.

FUEL TANK ASSY.



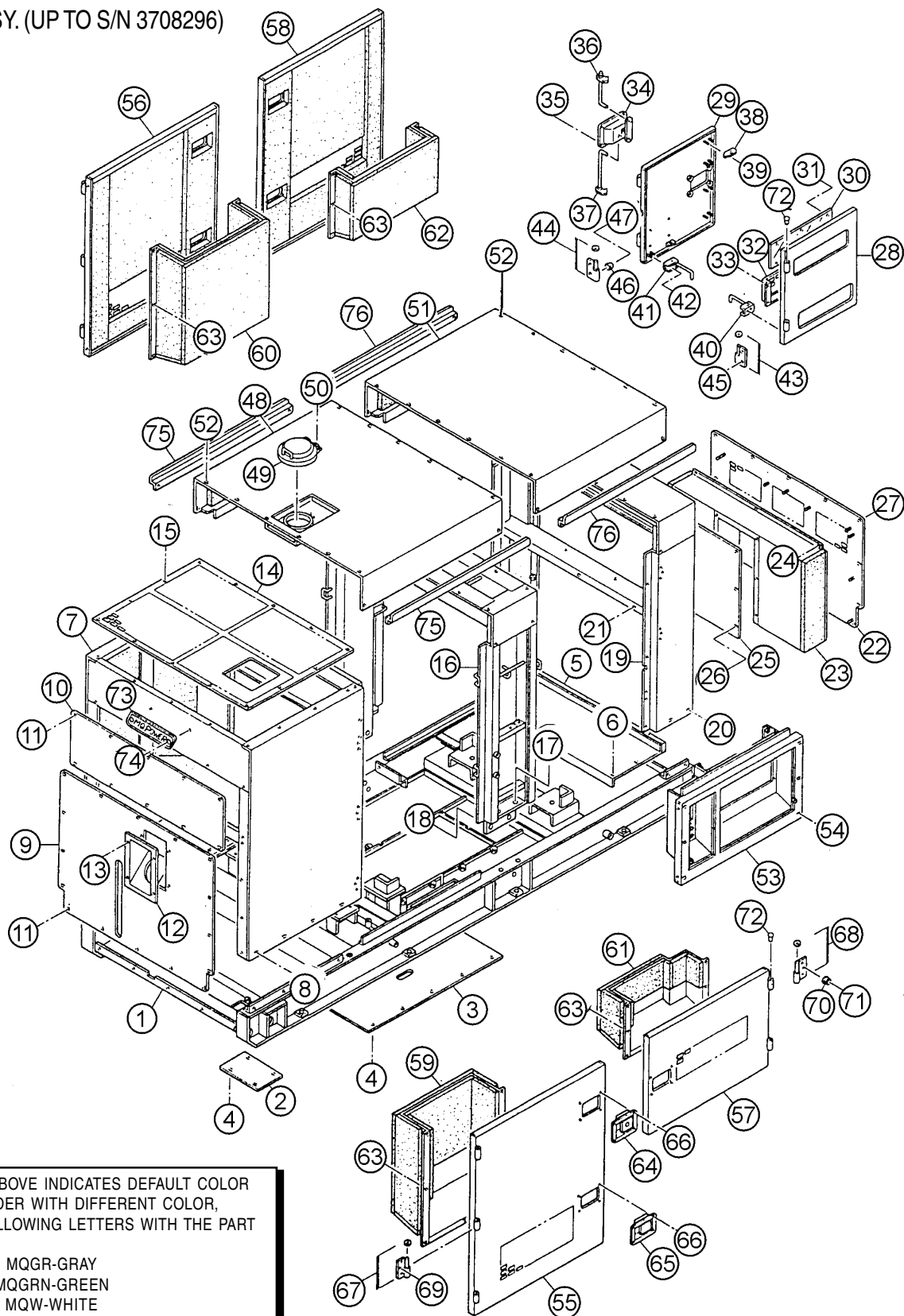
# DCA-300SSK FUEL TANK ASSY.

## FUEL TANK ASSY.

<u>NO.</u>	<u>PART NO.</u>	<u>PART NAME</u>	<u>QTY.</u>	<u>REMARKS</u>
1	C2364000303	FUEL TANK .....	1 .....	S/N 1337508 TO 2691258
1	C2364000313	FUEL TANK .....	1 .....	S/N 2691259~
2	0605505030	CAP, FUEL TANK .....	1 .....	REPLACES 0605505005
2	0601850590	KEY, FUEL TANK .....	1 .....	REPLACES 0601850505
3	0810105400	FUEL FILTER	1	
4	0264100485	HOSE, FUEL GAUGE	1	
4	0264100525	HOSE, FUEL GAUGE .....	1 .....	S/N 3708297~
5	0605515079	HOSE BAND	2	
6	0605503023	FUEL SENSOR .....	1 .....	FF-9
7	0802120604	PACKING	1	
8	0605501050	UNIT FUEL .....	1 .....	52000-KA9810
9	0602021155	PACKING .....	1 .....	52391-KW3700
10	0027104010	MACHINE SCREW .....	5 .....	S/N 3691259~
10	0022905015	MACHINE SCREW .....	5 .....	S/N 1337508 TO 2691258
11	8195523104	TANK BAND	2	
12	0805003414	PAD, TANK BAND	4	
13	0017108020	HEX. HEAD BOLT	2	
14	0037908000	HEX. NUT	2	
15	0222100300	TANK SHEET	6	
16	0130206000	STREET ELBOW	1	
17	3515512014	DRAIN PIPE	1	
18	0603325011	VALVE .....	1 .....	BBS-77-15 PT1/2
19	0132006000	PLUG	1	
20	0845039604	RUBBER SEAL	1	
21	0191302000	SUCTION HOSE .....	1 .....	UP TO S/N 1337973
21	0191302300	SUCTION HOSE .....	1 .....	FROM S/N 1337974
22	0191302240	RETURN HOSE .....	1 .....	UP TO S/N 1337973
22	0191302800	RETURN HOSE .....	1 .....	FROM S/N 1337974
23	0605515109	HOSE BAND	4	

# DCA-300SSK ENCLOSURE ASSY. (UP TO S/N 3708296)

ENCLOSURE ASSY. (UP TO S/N 3708296)



THE PART NUMBER ABOVE INDICATES DEFAULT COLOR OF ORANGE. TO ORDER WITH DIFFERENT COLOR, PLEASE ADD THE FOLLOWING LETTERS WITH THE PART NUMBER:

MQGR-GRAY  
MQGRN-GREEN  
MQW-WHITE

THE SERIAL NUMBER MAY BE REQUIRED.

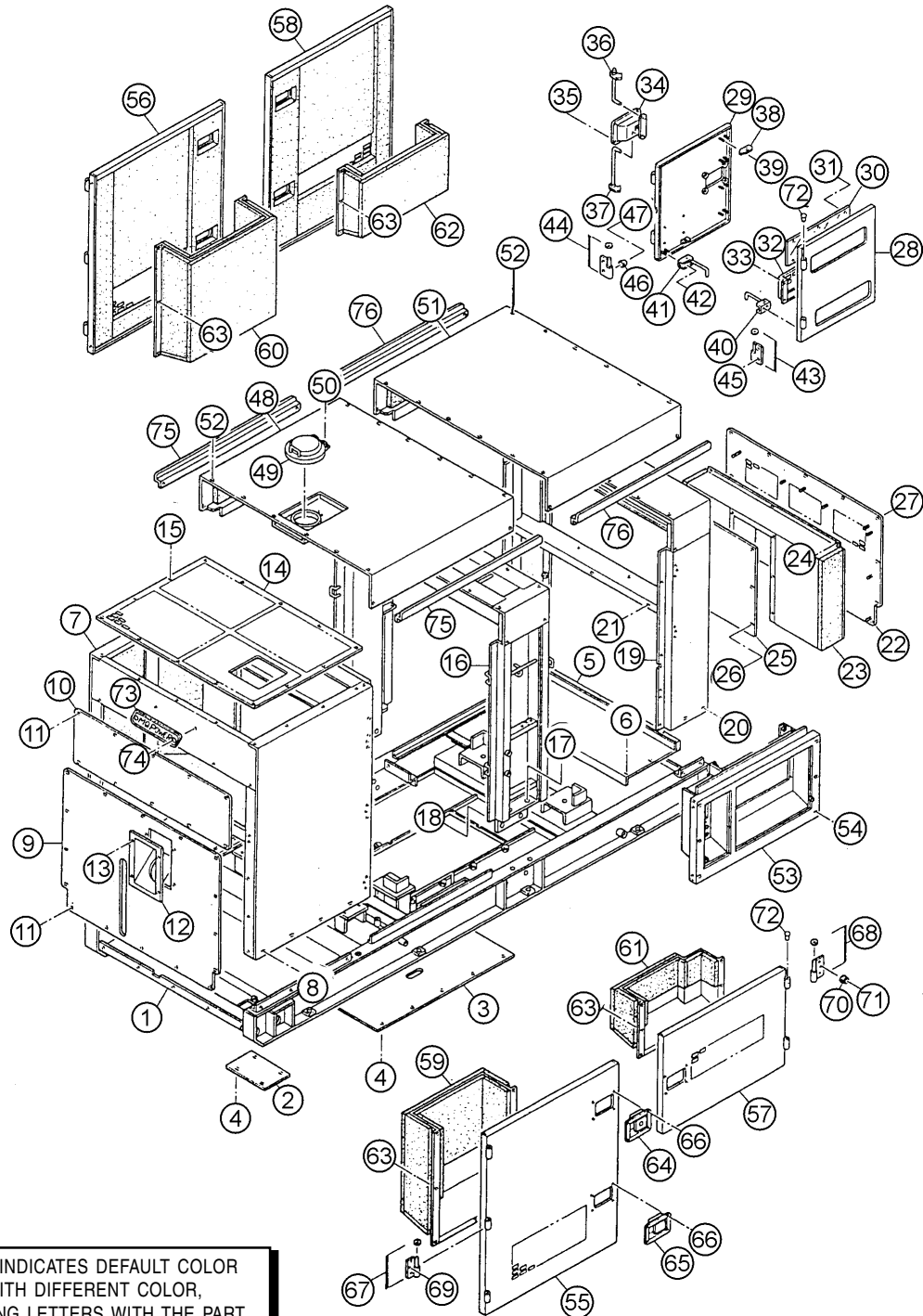
# DCA-300SSK ENCLOSURE ASSY. (UP TO S/N 3708296)

ENCLOSURE ASSY. (UP TO S/N 3708296)

<u>NO.</u>	<u>PART NO.</u>	<u>PART NAME</u>	<u>QTY.</u>	<u>REMARKS</u>
1	C2414000002	BASE .....	1	S/N 1337508 TO 3691258
1	C2414000402	BASE .....	1	S/N 3691259 TO 3701673
1	C2415000002	BASE .....	1	S/N 3701674 TO 3708296
2	C3414100104	FLOOR PANEL	1	
3	C2414100004	FLOOR PANEL	1	
4	0019208020	HEX. HEAD BOLT	14	
5	C2414600004	DUCT	1	
5	C2494000004	LINING .....	1	TO S/N 3708296
6	0017108020	HEX. HEAD BOLT	4	
7	C2424000402	FRONT FRAME .....	1	S/N3691259 TO 3701673
7	C2425000202	FRONT FRAME .....	1	S/N3701674 TO 3705209
7	C2425000212	FRONT FRAME .....	1	S/N3705210 TO 3708296
7	C2494100003	LINING .....	1	TO S/N 3708296
8	0019210025	HEX. HEAD BOLT	8	
9	C2424200003	COVER, FRONT FRAME	1	
10	C2424200104	COVER, FRONT FRAME	1	
10	C2494100104	LINING	1	
11	0019208020	HEX. HEAD BOLT	26	
12	0845042703	FILLER BRACKET	1	
13	0019208020	HEX. HEAD BOLT	4	
14	C2424200203	COVER, FRONT FRAME	1	
15	0019208020	HEX. HEAD BOLT	14	
16	C2434000102	CENTER FRAME .....	1	UP TO S/N 1337973
16	C2434000112	CENTER FRAME .....	1	S/N 1337974 TO 3708296
17	0010114050	HEX. HEAD BOLT	4	
17	0030014000	HEX. NUT	4	
17	0040014000	LOCK WASHER	4	
17	0041214000	PLAIN WASHER	8	
18	0010114040	HEX. HEAD BOLT	8	
18	0030014000	HEX. NUT	8	
18	0040014000	LOCK WASHER	8	
18	0041214000	PLAIN WASHER	16	
19	C2444000302	REAR FRAME	1	
19	C2494300204	LINING	1	
20	0019210025	HEX. HEAD BOLT	4	
21	0017110025	HEX. HEAD BOLT	3	
22	C2444300004	COVER, REAR FRAME	1	
22	C2494300004	LINING	1	
23	C2444300203	DUCT .....	1	TO S/N 3708296
23	C2494300304	LINING .....	1	TO S/N 3708296
24	0207008000	HEX. NUT	15	
25	C2444300104	PANEL	1	
25	C2494300104	LINING	1	
26	0017108020	HEX. HEAD BOLT	6	
27	0019208020	HEX. HEAD BOLT	14	

# DCA-300SSK ENCLOSURE ASSY. (UP TO S/N 3708296)

ENCLOSURE ASSY. (UP TO S/N 3708296)



THE PART NUMBER ABOVE INDICATES DEFAULT COLOR OF ORANGE. TO ORDER WITH DIFFERENT COLOR, PLEASE ADD THE FOLLOWING LETTERS WITH THE PART NUMBER:

MQGR-GRAY  
MQGRN-GREEN  
MQW-WHITE

THE SERIAL NUMBER MAY BE REQUIRED.

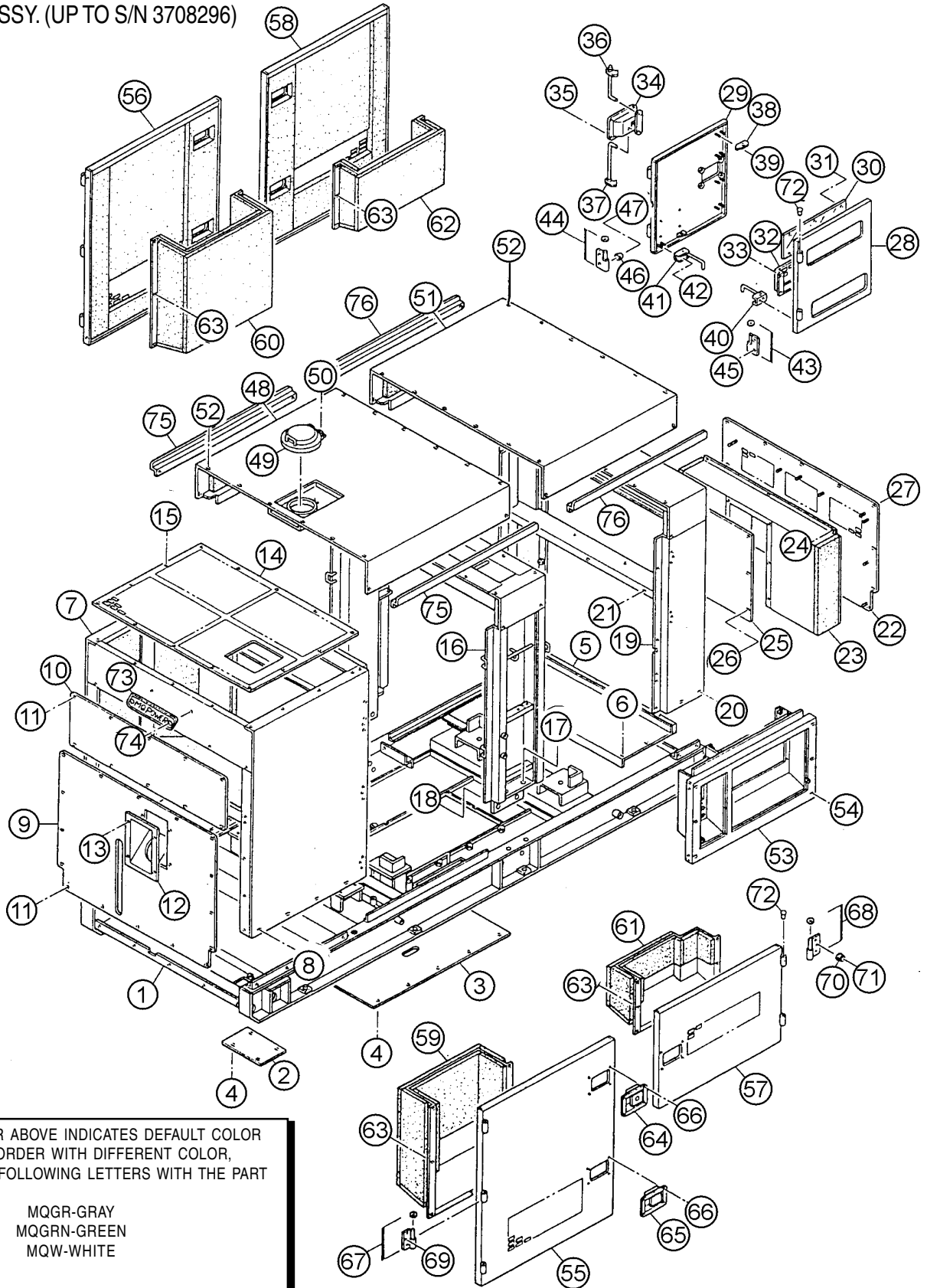
# DCA-300SSK ENCLOSURE ASSY. (UP TO S/N 3708296)

ENCLOSURE ASSY. (UP TO S/N 3708296)

<u>NO.</u>	<u>PART NO.</u>	<u>PART NAME</u>	<u>QTY.</u>	<u>REMARKS</u>
28	C2444200003	DOOR, REAR FRAME	1	
29	C2444200103	DOOR, REAR FRAME	1	
30	8225147004	WINDOW PLATE	2	
31	0037906000	HEX. NUT	12	
32	B9114500104	DOOR POCKET	1	
33	0207006000	HEX. NUT	4	
34	B9114000102	DOOR HANDLE	1	
35	0021806016	MACHINE SCREW	4	
35	0030006000	HEX. NUT	4	
36	C3444700004	DOOR ROD	1	
37	8195146304	DOOR ROD	1	
38	0845050704	STAY	4	
39	0207006000	HEX. NUT	8	
40	0805011304	STOPPER, DOOR	1	
41	0805011204	STOPPER, DOOR	1	
42	0207006000	HEX. NUT	4	
43	M9110100304	HINGE .....	2	REPLACES 0845047104
43	0845045004	WASHER	2	
44	M9110100304	HINGE .....	2	REPLACES 0845047204
44	0845045004	WASHER	2	
45	0019208020	HEX. HEAD BOLT	6	
46	0601850097	STOPPER	2	
47	0025008025	MACHINE SCREW	2	
48	C2464100002	ROOF PANEL .....	1	TO S/N 3708296
48	C2494500004	LINING .....	1	TO S/N 3708296
49	0800251701	FILLER COVER	1	
50	0025006016	MACHINE SCREW	2	
50	0042306000	LOCK WASHER	2	
50	0042406000	PLAIN WASHER	2	
51	C2464200002	ROOF PANEL .....	1	TO S/N 3708296
51	C2494500104	LINING .....	1	TO S/N 3708296
52	0019208020	HEX. HEAD BOLT	32	
53	C2454200402	SPLASHER PANEL .....	1	UP TO S/N 1337973
53	C2454200412	SPLASHER PANEL .....	1	FROM S/N 1337974 TO 3691258
53	C2454200422	SPLASHER PANEL .....	1	S/N 3691259 TO 3696506
53	C2454200432	SPLASHER PANEL .....	1	S/N3696507 TO 3700673
53	C2454200442	SPLASHER PANEL .....	1	S/N3700674 TO 3706720
53	C2454200452	SPLASHER PANEL .....	1	S/N3706721 TO 3708296
54	0019108065	HEX. HEAD BOLT	6	
54	0042308000	LOCK WASHER	6	
54	0042408000	PLAIN WASHER	6	
55	C2454000203	SIDE DOOR .....	1	TO S/N 3708296
55	C2494400404	LINING .....	1	TO S/N 3708296
56	C2454000303	SIDE DOOR .....	1	TO S/N 3708296
56	C2494400604	LINING .....	1	TO S/N 3708296

# DCA-300SSK ENCLOSURE ASSY. (UP TO S/N 3708296)

ENCLOSURE ASSY. (UP TO S/N 3708296)



THE PART NUMBER ABOVE INDICATES DEFAULT COLOR OF ORANGE. TO ORDER WITH DIFFERENT COLOR, PLEASE ADD THE FOLLOWING LETTERS WITH THE PART NUMBER:

MQGR-GRAY  
MQGRN-GREEN  
MQW-WHITE

THE SERIAL NUMBER MAY BE REQUIRED.

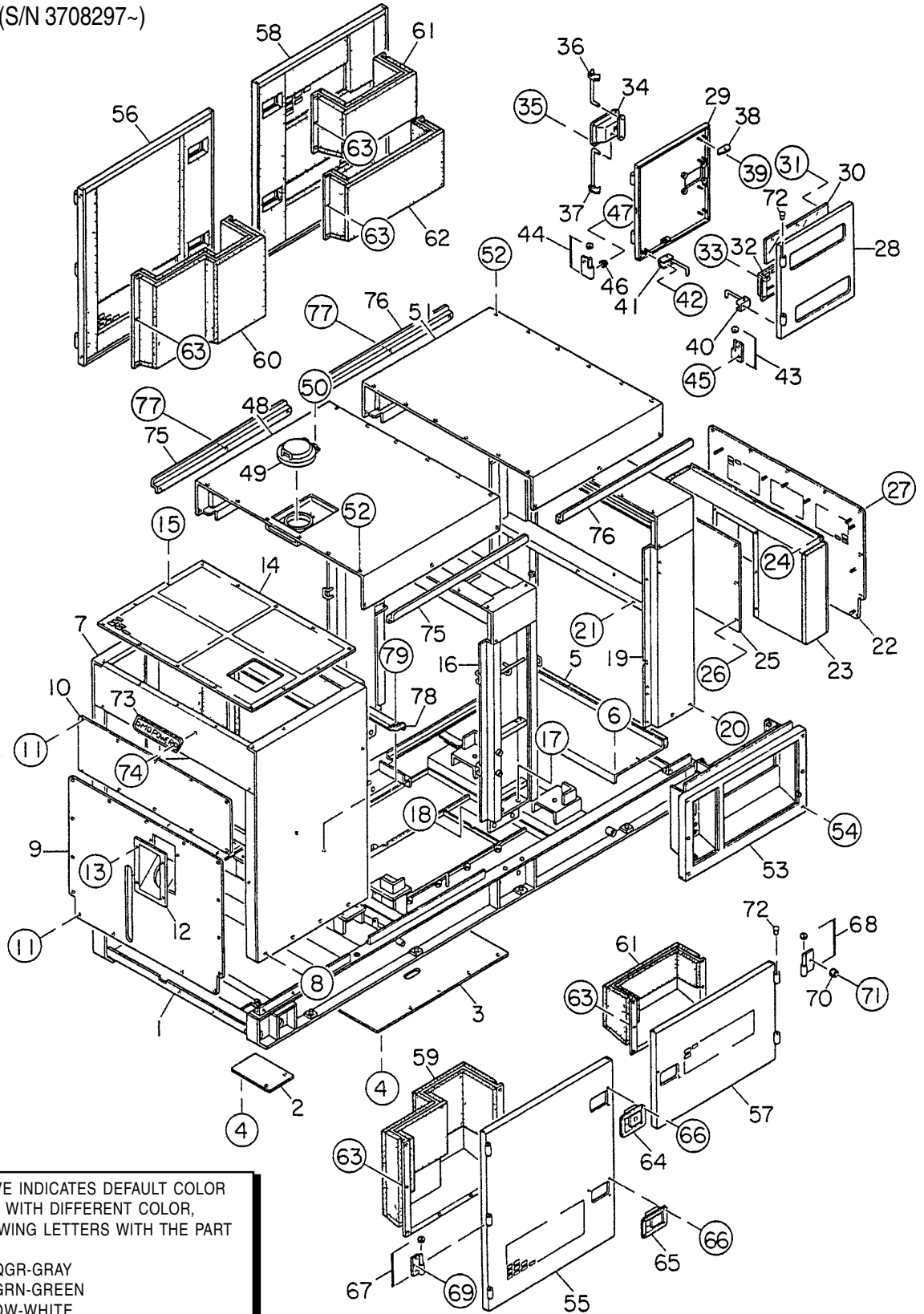
# DCA-300SSK ENCLOSURE ASSY. (UP TO S/N 3708296)

ENCLOSURE ASSY. (UP TO S/N 3708296)

<u>NO.</u>	<u>PART NO.</u>	<u>PART NAME</u>	<u>QTY.</u>	<u>REMARKS</u>
57	C2454000003	SIDE DOOR .....	1 .....	TO S/N 3708296
57	C2494400004	LINING .....	1 .....	TO S/N 3708296
58	C2454000103	SIDE DOOR .....	1 .....	TO S/N 3708296
58	C2494400204	LINING .....	1 .....	TO S/N 3708296
59	C2494400504	DUCT .....	1 .....	TO S/N 3708296
59	C2494400504	LINING .....	1 .....	TO S/N 3708296
60	C2454300304	DUCT .....	1 .....	TO S/N 3708296
60	C2494400704	LINING .....	1 .....	TO S/N 3708296
61	C2454300004	DUCT .....	1 .....	TO S/N 3708296
61	C2494400104	LINING .....	1 .....	TO S/N 3708296
62	C2454300104	DUCT .....	1 .....	TO S/N 3708296
62	C2494400304	LINING .....	1 .....	TO S/N 3708296
63	0207008000	HEX. NUT	28	
64	B9114000002	DOOR HANDLE	4	
65	0825007362	DOOR HANDLE	3	
66	0021806016	MACHINE SCREW	28	
66	0030006000	HEX. NUT	28	
67	0845046904	HINGE	6	
67	0845045004	WASHER	6	
68	0845047004	HINGE	5	
68	0845045004	WASHER	5	
69	0019208020	HEX. HEAD BOLT	25	
70	0601850097	STOPPER	8	
71	0021008025	MACHINE SCREW	8	
72	0845031504	CAP	14	
73	0600500090	EMBLEM	2	
74	0021106016	MACHINE SCREW	4	
75	C2464500604	GUTTER .....	2 .....	S/N3707481 TO S/N3708296
76	C2464500704	GUTTER .....	2 .....	S/N3707481 TO S/N3708296

# DCA-300SSK ENCLOSURE ASSY. (S/N 3708297~)

ENCLOSURE ASSY. (S/N 3708297~)



THE PART NUMBER ABOVE INDICATES DEFAULT COLOR OF ORANGE. TO ORDER WITH DIFFERENT COLOR, PLEASE ADD THE FOLLOWING LETTERS WITH THE PART NUMBER:

MQGR-GRAY  
MQGRN-GREEN  
MQW-WHITE

THE SERIAL NUMBER MAY BE REQUIRED.

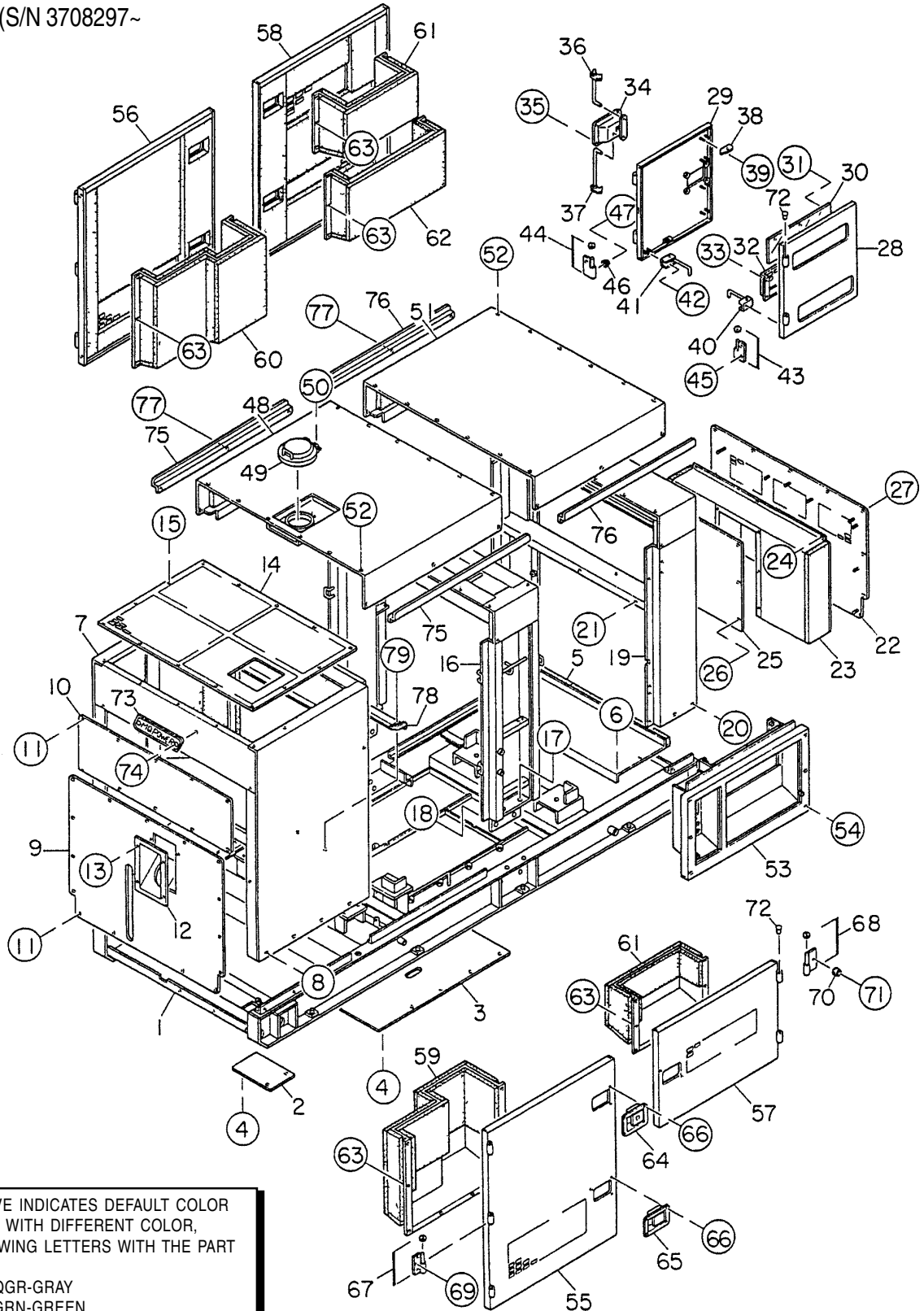
# DCA-300SSK ENCLOSURE ASSY. (S/N 3708297~)

ENCLOSURE ASSY. (S/N 3708297~)

<u>NO.</u>	<u>PART NO.</u>	<u>PART NAME</u>	<u>QTY.</u>	<u>REMARKS</u>
1	C24140 01002	BASE	1	
2	C34141 00104	PANEL, FLOOR	1	
3	C241410004	PANEL, FLOOR	1	
4	00192 08020	BOLT, HEX HEAD	14	
5	C24145 00204	DUCT	1	
5	C24940 00004	LINING	1	
6	00171 08020	BOLT, HEX HEAD	4	
7	C24240 01702	FRONT, FRAME	1	
7	C24941 00703	LINING	1	
8	00192 10025	BOLT, HEX HEAD	8	
9	C24242 00003	COVER, FRONT FRAME	1	
10	C24242 00104	COVER, FRONT FRAME	1	
10	C24941 00104	LINING	1	
11	00192 08020	BOLT, HEX HEAD	26	
12	08450 42703	BRACKET, FILLER	1	
13	00192 08020	BOLT, HEX HEAD	4	
14	C24242 00203	COVER, FRONT FRAME	1	
15	00192 08020	BOLT, HEX HEAD	14	
16	C24340 01002	FRAME, CENTER	1	
17	00101 14050	BOLT, HEX HEAD	4	
17	00300 14000	NUT, HEX	4	
17	00400 14000	WASHER, SPRING	4	
17	00412 14000	WASHER, PLAIN	8	
18	00101 14040	BOLT, HEX HEAD	8	
18	00300 14000	NUT, HEX	8	
18	00400 14000	WASHER, SPRING	8	
18	00412 14000	WASHER, PLAIN	16	
19	C24440 00302	FRAME, REAR	1	
19	C24943 00204	LINING	1	
20	00192 10025	BOLT, HEX HEAD	4	
21	00171 10025	BOLT, HEX HEAD	3	
22	C24443 00004	COVER, REAR FRAME	1	
22	C24943 00904	LINING	1	
23	C24443 00803	DUCT	1	
23	C24943 00904	LINING	1	
24	02070 08000	NUT, HEX	15	
25	C24443 00104	PANEL	1	
25	C24943 00104	LINING	1	
26	00171 08020	BOLT, HEX HEAD	6	
27	00192 08020	BOLT, HEX HEAD	14	
28	C24442 00003	DOOR, REAR FRAME	1	
29	C24442 00103	DOOR, REAR FRAME	1	
30	82251 47004	PLATE, WINDOW	2	
31	00379 06000	NUT, HEX	12	
32	B91145 00104	POCKET, DOOR	1	
33	02070 06000	NUT, HEX	4	

# DCA-300SSK ENCLOSURE ASSY. (S/N 3708297~)

ENCLOSURE ASSY. (S/N 3708297~)



THE PART NUMBER ABOVE INDICATES DEFAULT COLOR OF ORANGE. TO ORDER WITH DIFFERENT COLOR, PLEASE ADD THE FOLLOWING LETTERS WITH THE PART NUMBER:

MQGR-GRAY  
MQGRN-GREEN  
MQW-WHITE

THE SERIAL NUMBER MAY BE REQUIRED.

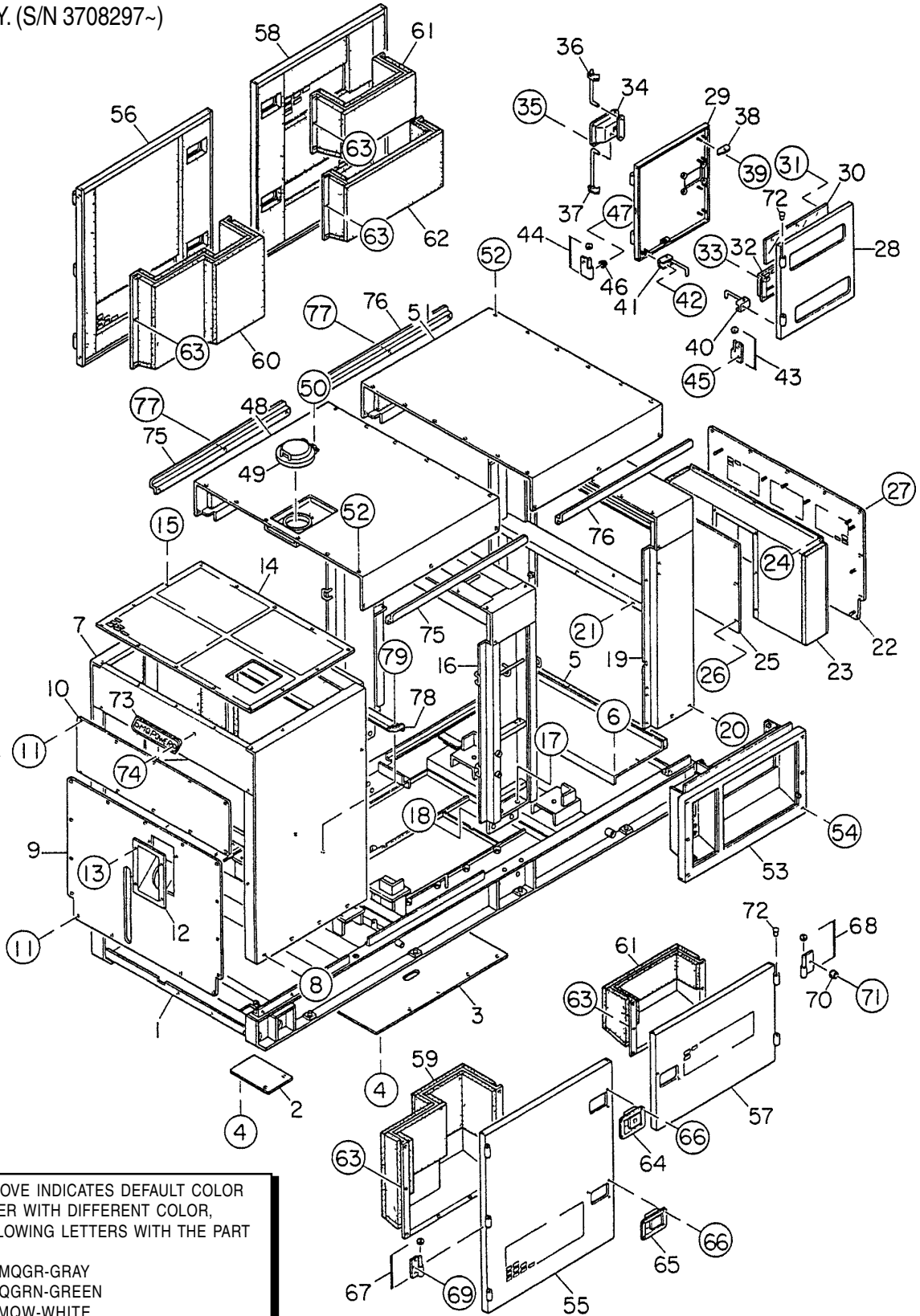
# DCA-300SSK ENCLOSURE ASSY. (S/N 3708297~)

ENCLOSURE ASSY. (S/N 3708297~)

<u>NO.</u>	<u>PART NO.</u>	<u>PART NAME</u>	<u>QTY.</u>	<u>REMARKS</u>
34	B91140 00102	HANDLE, DOOR	1	
35	00218 06016	SCREW, MACHINE	4	
35	00300 06000	NUT, HEX	4	
36	C34447 00004	ROD, DOOR	1	
37	81951 46304	ROD, DOOR	1	
38	08450 50704	STAY	4	
39	02070 06000	NUT, HEX	8	
40	08050 11304	STOPPER, DOOR	1	
41	08050 11204	STOPPER, DOOR	1	
42	02070 06000	NUT, HEX	4	
43	08450 47104	HINGE	2	
43	08450 45004	WASHER	2	
44	08450 47204	HINGE	2	
44	08450 45004	WASHER	2	
45	00192 08020	BOLT, HEX HEAD	6	
46	06018 50097	STOPPER	2	
47	00254 08025	SCREW, MACHINE	2	
48	C24641 00402	PANEL, ROOF	1	
48	C24945 00804	LINING	1	
49	08002 51701	COVER, FILLER	1	
50	00250 06015	SCREW, MACHINE	2	
50	00423 06000	WASHER, SPRING	2	
50	00424 06000	WASHER, PLAIN	2	
51	C24642 00502	PANEL, ROOF	1	
51	C24945 00904	LINING	1	
52	00192 08020	BOLT, HEX HEAD	32	
53	C24542 01402	PANEL, SPLASHER	1	
54	00191 08065	BOLT, HEX HEAD	6	
54	00423 08000	WASHER, SPRING	6	
54	00424 08000	WASHER, PLAIN	6	
55	C24540 02603	DOOR, SIDE	1	
55	C24944 06004	LINING	1	
56	C24540 02703	DOOR, SIDE	1	
56	C24944 06204	LINING	1	
57	C24540 02803	DOOR, SIDE	1	
57	C24944 05504	LINING	1	
58	C24540 03003	DOOR, SIDE	1	
58	C24944 05804	LINING	1	
59	C24543 02704	DUCT	1	
59	C24944 06104	LINING	1	
60	C24543 02704	DUCT	1	
60	C24944 06104	LINING	1	
61	C24543 02704	DUCT	2	
61	C24944 06104	LINING	2	
62	C24543 02704	DUCT	1	
62	C24944 06104	LINING	1	

# DCA-300SSK ENCLOSURE ASSY. (S/N 3708297~)

ENCLOSURE ASSY. (S/N 3708297~)



THE PART NUMBER ABOVE INDICATES DEFAULT COLOR OF ORANGE. TO ORDER WITH DIFFERENT COLOR, PLEASE ADD THE FOLLOWING LETTERS WITH THE PART NUMBER:

MQGR-GRAY  
MQGRN-GREEN  
MQW-WHITE

THE SERIAL NUMBER MAY BE REQUIRED.

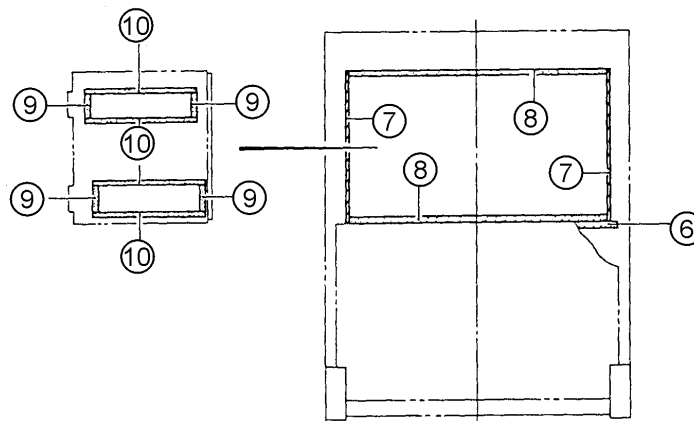
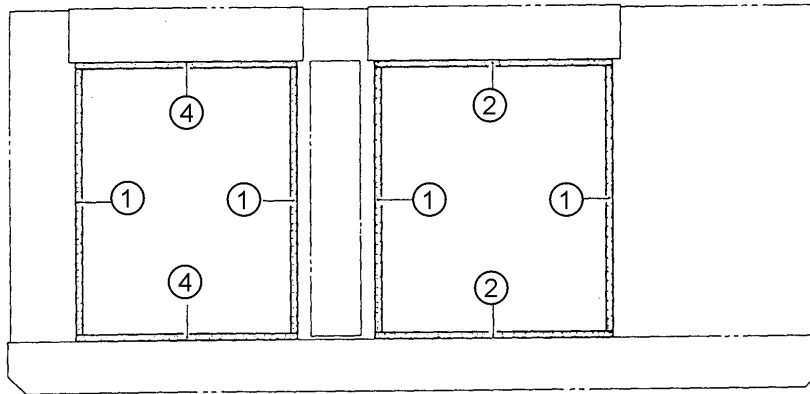
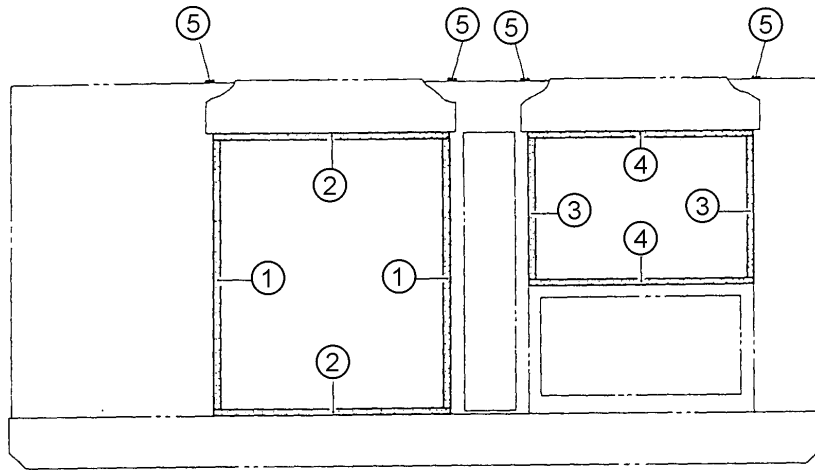
# DCA-300SSK ENCLOSURE ASSY. (S/N 3708297~)

ENCLOSURE ASSY. (S/N 3708297~)

<u>NO.</u>	<u>PART NO.</u>	<u>PART NAME</u>	<u>QTY.</u>	<u>REMARKS</u>
63	02070 08000	NUT, HEX	28	
64	B91140 00002	HANDLE, DOOR	4	
65	08250 07362	HANDLE, DOOR	3	
66	00218 06016	SCREW, MACHINE	28	
66	00300 06000	NUT, HEX	16	
67	08450 46904	HINGE	6	
67	08450 45004	WASHER	6	
68	08450 47004	HINGE	5	
68	08450 45004	WASHER	5	
69	00192 08020	BOLT, HEX HEAD	25	
70	06018 50097	STOPPER	8	
71	00254 08025	SCREW, MACHINE	8	
72	08450 31504	CAP	15	
73	06005 00090	EMBLEM	2	
74	00211 06016	SCREW, MACHINE	4	
75	C24645 00204	GUTTER	2	
77	0019208020	HEX. HEAD BOLT	4	
78	C1425700004	RADIATOR PANEL	1	
79	0019206015	HEX. HEAD BOLT	4	

# DCA-300SSK RUBBER SEAL ASSY.

RUBBER SEAL ASSY.



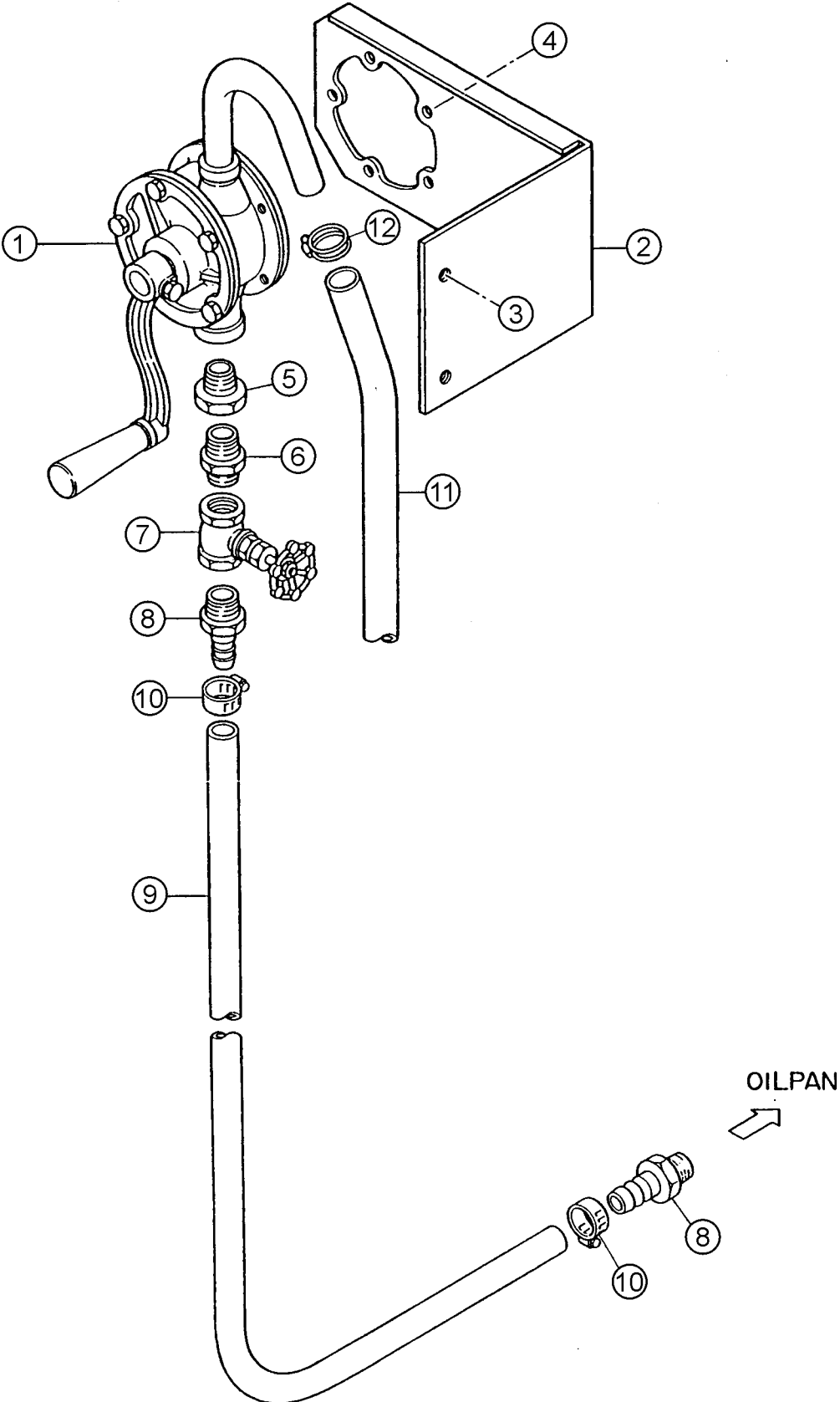
# DCA-300SSK RUBBER SEAL ASSY.

## RUBBER SEAL ASSY.

<u>NO.</u>	<u>PART NO.</u>	<u>PART NAME</u>	<u>QTY.</u>	<u>REMARKS</u>
1	0228901250	RUBBER SEAL	6	
2	0228901090	RUBBER SEAL	4	
3	0228900650	RUBBER SEAL	2	
4	0228901030	RUBBER SEAL	4	
5	0229201400	RUBBER SEAL	4	
6	0229201300	RUBBER SEAL	1	
7	0228800705	RUBBER SEAL .....	2	S/N3691259 TO 3701673
7	0221200705	RUBBER SEAL .....	2	S/N3701674~
8	0228801200	RUBBER SEAL	2	
9	0228100120	RUBBER SEAL	4	
10	0228100510	RUBBER SEAL	4	

**DCA-300SSK OIL PIPING ASSY.**

OIL PIPING ASSY.



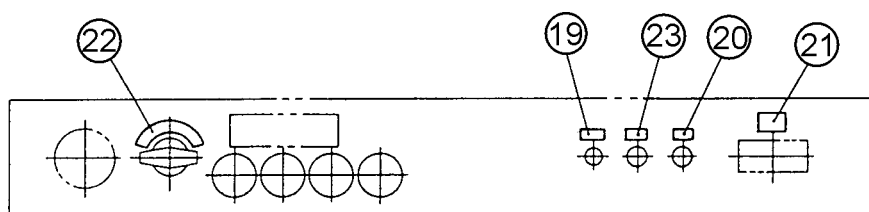
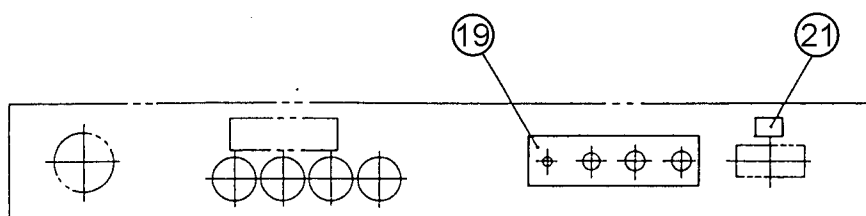
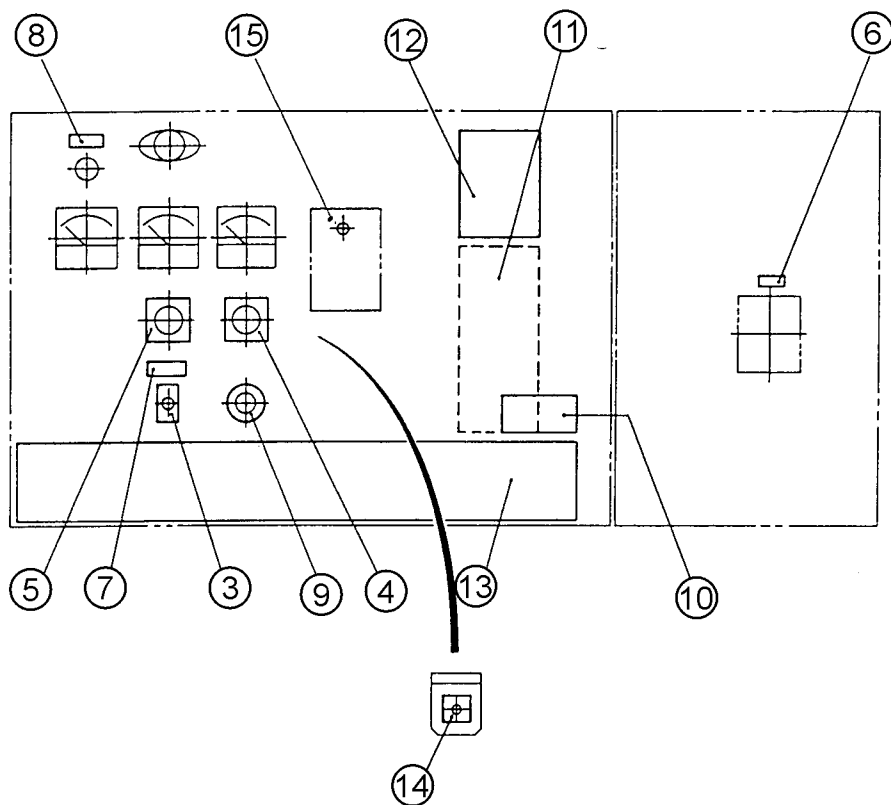
## DCA-300SSK OIL PIPING ASSY.

### OIL PIPING ASSY.

<u>NO.</u>	<u>PART NO.</u>	<u>PART NAME</u>	<u>QTY.</u>	<u>REMARKS</u>
1	0602023040	PUMP	1	
2	C2324400004	BRACKET, PUMP	1	
3	0017110025	HEX., HEAD BOLT	2	
4	0017106025	HEX., HEAD BOLT	5	
5	7522054204	BUSHING	1	
6	0131506000	NIPPLE	1	
7	0120006005	VALVE	1	
8	3972027104	HOSE JOINT	2	
9	0191600900	HOSE	1	
10	0605515074	HOSE BAND	2	
11	0193301200	HOSE	1	
12	0605515004	HOSE BAND	1	

# DCA-300SSK NAME PLATE AND DECALS

## NAME PLATE AND DECALS



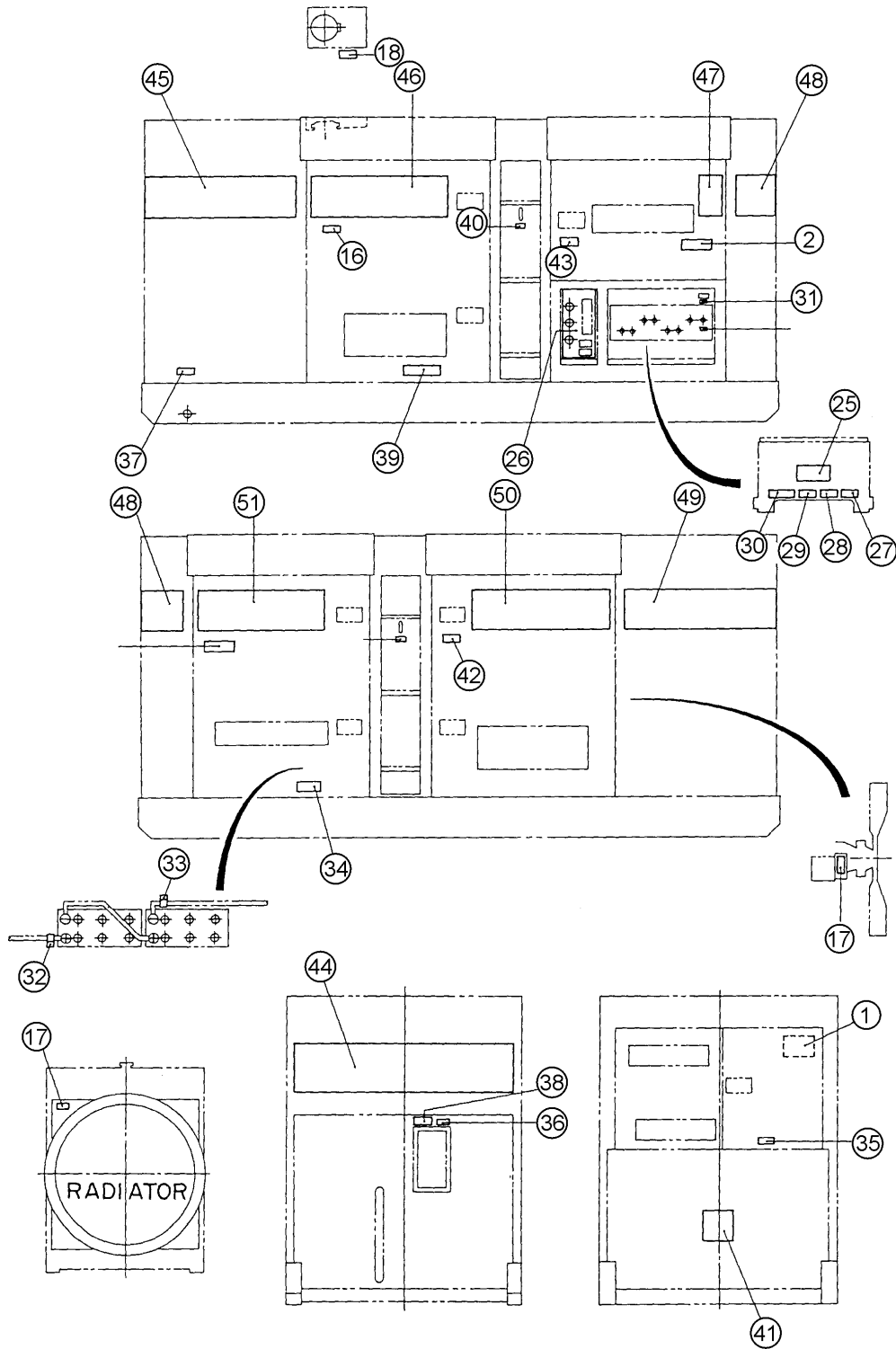
# DCA-300SSK NAME PLATE AND DECALS

## NAME PLATE AND DECALS

<u>NO.</u>	<u>PART NO.</u>	<u>PART NAME</u>	<u>QTY.</u>	<u>REMARKS</u>
1	0800655603	DECAL; HANDLING PROCED.; S2763A	1	S/N3691259 TO 3696506
1	C155100503	DECAL; HANDLING PROCED.; C1510050	1	S/N3696507 TO 3701673
1	C155200403	DECAL; HANDLING PROCED.; C1520040	1	S/N3701674~
2	B155200103	DECAL; CAUTION; B15200010	2	S/N3696507 TO 3701673
2	C952210003	DECAL; CAUTION; C92210000	2	S/N3701674~
CONTROL BOX GROUP				
3	0800520100	PLATE; ON-OFF .....	1	AT-202
4	0800520904	PLATE; AMMETER CHNG.-OVR SWITCH .....	1	N-2438
5	0800520814	PLATE; VOLTMETER CHNG.-OVR SWITCH ..	1	N-2439
6	0840624504	DECAL; CIRCUIT BREAKER .....	1	S-3031
7	0840624704	DECAL; PILOT LAMP .....	1	S-3033
8	0840624604	DECAL; PANEL LIGHT SWITCH .....	1	S-3032
9	0840624804	DECAL; VOLTAGE REGULATOR .....	1	S-3034
10	B9531100604	DECAL; WARNING .....	1	B93110060
11	C0551000903	DECAL; SETTING FOR OUTPUT VOLTAGE. .	1	C0510009
12	C2551000004	DECAL; SAFETY INSTRUCTIONS .....	1	C25100000
13	C2561101903	DECAL; WHISPERWATT 300 .....	1	C26110190
14	C9502400004	DECAL; HIGH IDLE SPEED, C90240000	1	S/N3701674~
15	0600500091	DECAL; ENGINE CONTROLLER .....	1	S/N3696507~
ENGINE OPERATING PANEL GROUP				
19	0840625004	DECAL; PREHEAT LAMP, S-3036 .....	1	S/N3691259 TO 3701673
19	C155200013	DECAL; OPERATING PANEL, C15200001	1	S/N3701674~
20	0840625104	DECAL; STARTER SWITCH, S-3037 .....	1	S/N3691259 TO 3696506
20	C9501400304	DECAL; PREHEAT BUTTON, C90140030	1	S/N3696507 TO 3701673
21	C0551000504	DECAL; BATTERY SWITCH .....	1	C05100050
22	C0551000704	DECAL; LOW-HIGH, C05100070 .....	1	S/N3691259 TO 3701673
23	C0551000804	DECAL; STOP BUTTON, C05100080 .....	1	S/N3691259 TO 3696506
23	0840647804	DECAL; EMERGENCY STOP, S4100 .....	1	S/N3696507 TO 3701673
5-1	0840614104	DECAL; GROUND	1	S-2635
5-2	0840619904	DECAL; DANGER	1	S-2731
5-3	B4551000103	DECAL; RECEPT. & CIRCT. BREAKER	1	B45100010
5-4	B9511100304	DECAL; WARNING	1	B91110030
5-5	B9511100404	DECAL; WARNING	1	B91110040
5-6	B9531100504	DECAL; WARNING	1	B93110050
5-7	C0551000404	DECAL; 3-PHASE OUTPUT TERMINAL	1	C05100040
5-8	C1551000404	DECAL; 240/139 VOLT	2	C15100040

# DCA-300SSK NAME PLATE AND DECALS

## NAME PLATE AND DECALS



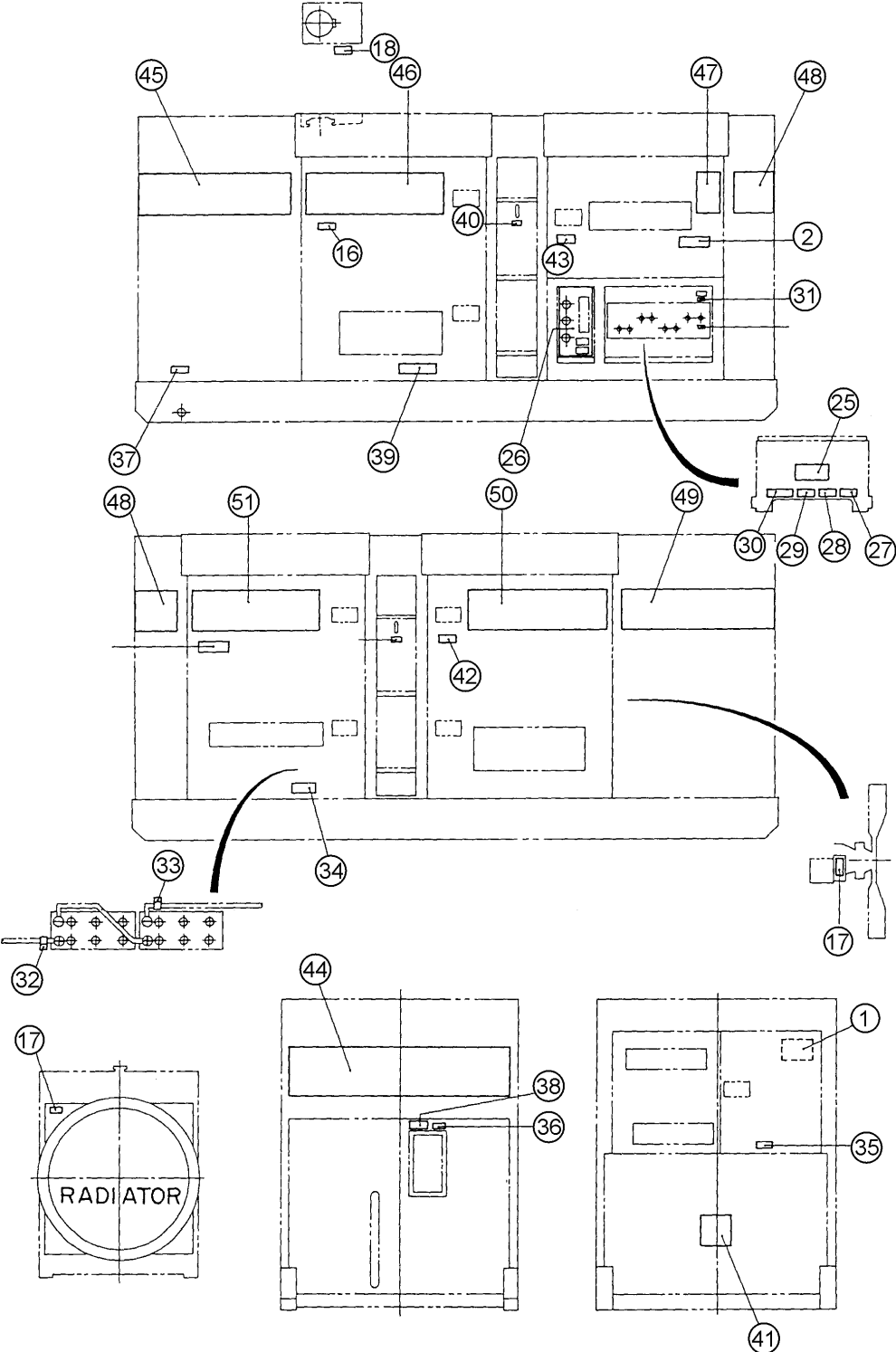
# DCA-300SSK NAME PLATE AND DECALS

## NAME PLATE AND DECALS

<u>NO.</u>	<u>PART NO.</u>	<u>PART NAME</u>	<u>QTY.</u>	<u>REMARKS</u>
<b>ENGINE &amp; RADIATOR GROUP</b>				
16	6360610304	DECAL; WATER .....	1 .....	S-1880
17	B9504000404	DECAL; WARNING .....	2 .....	B90400040
18	B9504100104	DECAL; WARNING .....	1 .....	B90410010
<b>OUTPUT TERMINAL GROUP</b>				
24	0840614104	DECAL; GROUND .....	1 .....	S-2635
25	0840619904	DECAL; DANGER .....	1 .....	S-2731
26	B4551000103	DECAL; RECEPT. & CIRCT. BREAKER, B45100010 .	1 .....	S/N3691259 TO 3706720
26	C1551000803	DECAL; RECEPT. & CIRCT. BREAKER, C15100080 .	1 .....	S/N3706721~
27	B9511100304	DECAL; WARNING .....	1 .....	B91110030
28	B9511100404	DECAL; WARNING .....	1 .....	B91110040
29	B9531100504	DECAL; WARNING .....	1 .....	B93110050
30	C0551000404	DECAL; 3-PHASE OUTPUT TERMINAL .....	1 .....	C05100040
31	C1551000404	DECAL; 240/139 VOLT, C15100040 .....	2 .....	UP TO S/N3696506
31	9039209064	DECAL; START CONTACT, S4468 .....	1 .....	S/N3696507~
<b>BATTERY GROUP</b>				
32	0800689404	DECAL; + .....	1 .....	S-2090
33	0800689504	DECAL; - .....	1 .....	S-2091
34	C9505300004	DECAL; CAUTION .....	1 .....	C90530000
<b>MUFFLER GROUP</b>				
35	B9504200004	DECAL; WARNING .....	1 .....	B90420000
<b>FUEL TANK GROUP</b>				
36	1320620904	DECAL; DIESEL FUEL .....	1 .....	S-1756
37	6360620004	DECAL; FUEL DRAIN PLUG .....	1 .....	S-1883
38	B9504500004	DECAL; WARNING .....	1 .....	B90450000

# DCA-300SSK NAME PLATE AND DECALS

## NAME PLATE AND DECALS



# DCA-300SSK NAME PLATE AND DECALS

## NAME PLATE AND DECALS

<u>NO.</u>	<u>PART NO.</u>	<u>PART NAME</u>	<u>QTY.</u>	<u>REMARKS</u>
		ENCLOSURE GROUP		
39	1320610603	DECAL; WATER-OIL .....	1 .....	S-1760
40	1320621504	DECAL; SUPPORT HOOK .....	2 .....	S-2257
41	0840625902	DECAL; MQ .....	1 .....	S-3057
42	B9504000304	DECAL; CAUTION .....	1 .....	B90400030
43	B9531100604	DECAL; WARNING .....	1 .....	B93110060
44	C2561101003	STRIPE	1	
45	C2561101603	STRIPE	1	
46	C2561101303	STRIPE	1	TO S/N 3708296
46	C2561102003	STRIPE	1	S/N 3708297~
47	C2561101404	STRIPE	1	TO S/N 3708296
47	C2561102103	STRIPE	2	S/N 3708297~
48	C2561101204	STRIPE	2	
49	C2561101803	STRIPE	1	
50	C2561101503	STRIPE	1	TO S/N 3708296
50	C2561102203	STRIPE	1	S/N 3708297~
51	C2561101703	STRIPE	1	TO S/N 3708296

**PAYMENT TERMS**

Terms of payment for parts are net 10 days.

**FREIGHT POLICY**

All parts orders will be shipped collect or prepaid with the charges added to the invoice. All shipments are F.O.B. point of origin. Multiquip's responsibility ceases when a signed manifest has been obtained from the carrier, and any claim for shortage or damage must be settled between the consignee and the carrier.

**MINIMUM ORDER**

The minimum charge for orders from Multiquip is \$15.00 net. Customers will be asked for instructions regarding handling of orders not meeting this requirement.

**RETURNED GOODS POLICY**

Return shipments will be accepted and credit will be allowed, subject to the following provisions:

1. A Returned Material Authorization must be approved by Multiquip prior to shipment.
2. To obtain a Return Material Authorization, a list must be provided to Multiquip Parts Sales that defines item numbers, quantities, and descriptions of the items to be returned.
  - a. The parts numbers and descriptions must match the current parts price list.
  - b. The list must be typed or computer generated.
  - c. The list must state the reason(s) for the return.
  - d. The list must reference the sales order(s) or invoice(s) under which the items were originally purchased.
  - e. The list must include the name and phone number of the person requesting the RMA.
3. A copy of the Return Material Authorization must accompany the return shipment.
4. Freight is at the sender's expense. All parts must be returned freight prepaid to Multiquip's designated receiving point.

5. Parts must be in new and resalable condition, in the original Multiquip package (if any), and with Multiquip part numbers clearly marked.

6. The following items are not returnable:

- a. Obsolete parts. (If an item is in the price book and shows as being replaced by another item, it is obsolete.)
- b. Any parts with a limited shelf life (such as gaskets, seals, "O" rings, and other rubber parts) that were purchased more than six months prior to the return date.
- c. Any line item with an extended dealer net price of less than \$5.00.
- d. Special order items.
- e. Electrical components.
- f. Paint, chemicals, and lubricants.
- g. Decals and paper products.
- h. Items purchased in kits.

7. The sender will be notified of any material received that is not acceptable.

8. Such material will be held for five working days from notification, pending instructions. If a reply is not received within five days, the material will be returned to the sender at his expense.

9. Credit on returned parts will be issued at dealer net price at time of the original purchase, less a 15% restocking charge.

10. In cases where an item is accepted, for which the original purchase document can not be determined, the price will be based on the list price that was effective twelve months prior to the RMA date.

11. Credit issued will be applied to future purchases only.

**PRICING AND REBATES**

Prices are subject to change without prior notice. Price changes are effective on a specific date and all orders received on or after that date will be billed at the revised price. Rebates for price declines and added charges for price increases will not be made for stock on hand at the time of any price change.

Multiquip reserves the right to quote and sell direct to Government agencies, and to Original Equipment Manufacturer accounts who use our products as integral parts of their own products.

**SPECIAL EXPEDITING SERVICE**

A \$35.00 surcharge will be added to the invoice for special handling including bus shipments, insured parcel post or in cases where Multiquip must personally deliver the parts to the carrier.

**LIMITATIONS OF SELLER'S LIABILITY**

Multiquip shall not be liable here under for damages in excess of the purchase price of the item with respect to which damages are claimed, and in no event shall Multiquip be liable for loss of profit or good will or for any other special, consequential or incidental damages.

**LIMITATION OF WARRANTIES**

No warranties, express or implied, are made in connection with the sale of parts or trade accessories nor as to any engine not manufactured by Multiquip. Such warranties made in connection with the sale of new, complete units are made exclusively by a statement of warranty packaged with such units, and Multiquip neither assumes nor authorizes any person to assume for it any other obligation or liability whatever in connection with the sale of its products. Apart from such written statement of warranty, there are no warranties, express, implied or statutory, which extend beyond the description of the products on the face hereof.



# **PARTS AND OPERATION MANUAL**

## **HERE'S HOW TO GET HELP**

*PLEASE HAVE THE MODEL AND SERIAL  
NUMBER ON-HAND WHEN CALLING*

### ***PARTS DEPARTMENT***

*800-427-1244 or 310-537-3700*

*FAX: 800-672-7877 or 310-637-3284*

### ***SERVICE DEPARTMENT***

*800-421-1244*

*FAX: 310- 537-4259*

### ***TECHNICAL ASSISTANCE***

*800-478-1244*

*FAX: 310- 631-5032*

### ***WARRANTY DEPARTMENT***

*888-661-4279, or 310-661-4279*

*FAX: 310- 537-1173*

Manufactured for Multiquip Inc.  
by  
DENYO CO., LTD, JAPAN



#### **MULTIQUIP INC.**

POST OFFICE BOX 6254  
CARSON, CA 90749  
310-537-3700 • 800-421-1244  
FAX: 310-537-3927  
E-MAIL: [mq@multiquip.com](mailto:mq@multiquip.com)  
WWW: [multiquip.com](http://multiquip.com)

Atlanta • Boise • Dallas • Houston • Newark  
Quebec, Canada • Manchester, UK • Rio De Janeiro, BR • Guadalajara, MX