

OPERATOR'S MANUAL

Generating set and industrial engines

12 liter (EDC III)

**VOLVO
PENTA**

Foreword

Volvo Penta industrial engines are relied upon throughout the world, in both mobile and stationary applications, under some of the most rigorous conditions imaginable. This is not by chance.

After more than 90 years of producing engines the name Volvo Penta has come to symbolize reliability, technical ingenuity, first-class performance and longevity. We believe that these characteristics are also ultimately your requirements and expectations for new Volvo Penta industrial engines.

To make certain that your expectations are matched, we ask that you read carefully through the instruction book before starting the engine.

Sincerely

AB VOLVO PENTA



Engine data

Engine designation Product number

Serial number

Clutch, type/nr.

Nearest Volvo Penta service location

Name Telephone

Address

Contents

Safety information	2	Maintenance schedule	26
Safety instructions for operation and maintenance	3	Maintenance schedule	26
		Newly rebuilt engine	27
Introduction	6	Maintenance	28
Environmental responsibility	6	Engine, general	28
Running-in	6	Lubrication system	32
Fuel and oils	6	Cooling system	35
Maintenance and reserve parts	6	Fuel system	41
Certified engines	7	Electric system	45
Presentation	8	Preparation for storage	49
Technical description	8	Preparation for storage	49
Identification numbers	9	Preparation after storage	50
Orientation	10	Troubleshooting	51
EDC III	11	Symptoms and possible causes	51
Instrument EDC III	12	Diagnostic function	52
DCU (Display Control Unit)	13	Fault messages	52
		Effect on engine	52
Starting the engine	19	Operation	53
Before starting	19	Fault codes	55
Starting procedure EDCIII	20	Technical data	64
Volvo Penta start lock	21	General	64
Start-up under extreme cold	22	Lubrication system	64
Never use starting fluid	23	Fuel system	65
Start-up with helper batteries	23	Cooling system	65
		Electric system	66
Operation	24		
Checking instruments	24		
Fault indication	24		
Operation at low load	24		
Shutting down the engine	25		
Prior to shut-down	25		
Shut-down	25		
After shut-down	25		
Extra shut-down	25		

CALIFORNIA

Proposition 65 Warning

Diesel engine exhaust and some of its constituents are known to the State of California to cause cancer, birth defects, and other reproductive harm.

Safety information

Read this chapter very carefully. It concerns your safety. How safety information is presented in the instruction book and on the product is described here. You will also find an overall picture of the basic safety procedures for operation of the engine.

Make sure that you have the correct instruction book before reading any further. If you do not, please contact your Volvo Penta dealer.



Incorrect operation can lead to injuries and/or product or property damage. It is therefore important to read through the instruction book very carefully before you start the engine or perform maintenance or service work. If there is anything that you are unclear on or unsure about even after reading the book, please contact your Volvo Penta dealer for assistance.

 This symbol is used in the instruction book and on the product to let you know that it concerns safety information. Always read this information very carefully.

In the instruction book warning texts are handled according to the following priority system:

 **WARNING!** Warns of risk of injury, extensive damage to the product or other property, or that serious functional problems can occur if the instruction is not followed.

 **IMPORTANT!** Used to call attention to things that can cause damage or functional problems to the product or property.

NOTE! Used to call attention to important information that can make the work process or operation go more smoothly.

 This symbol is used in certain cases on our products and refers to important information in the instruction book. Make sure that warning and information symbols on the engine and transmission are always visible and legible. Replace symbols that have been damaged or painted over.

Safety instructions for operation and maintenance

Daily checks

Make a habit of always visually checking the engine and engine compartment prior to operation (**before starting the engine**) and after operation (**after shutting down the engine**). This will help you to quickly notice if fuel, coolant or oil leaks or any other abnormal conditions have occurred or are occurring.

Fuel filling

There is a risk of fire and explosion when filling tanks with fuel. Smoking is forbidden and the engine must be stopped.

Never overfill the tank. Make sure that the cap is correctly closed.

Use only the fuel recommended in the instruction book. Fuel of the wrong grade can cause the engine to run incorrectly or not at all. On a diesel engine it can also lead to seizure of the injection system and over-revving the engine, putting both the machine and nearby people at risk.

Carbon monoxide poisoning

Only start the engine in a well-ventilated space. During operation in an enclosed space both exhaust and crankcase gases must be properly vented.

Operation

The engine should not be operated in environments with surrounding explosive substances due to the fact that the electrical and mechanical components can cause sparks.

Getting close to a running engine is a safety risk. Hair, fingers, loose-fitting clothing or a dropped tool can get caught in rotating parts causing severe injury.

If the engine has been delivered without protective coverings, all rotating parts and hot surfaces should be covered as necessary following installation to insure personal safety.

Starting lock

If the instrument panel does not have a key switch the engine compartment should be lockable to prevent unauthorized personnel from starting the engine. A lockable main switch may be used as an alternative.

Maintenance and service tasks

Knowledge

In the instruction book you will find instructions for how the most common maintenance and service tasks can be carried out in a safe and correct manner. Read the instructions carefully before initiating work.

Literature covering more extensive work is available from your Volvo Penta dealer.

Never attempt a procedure if you are not completely certain regarding how it should be performed. Contact your Volvo Penta dealer for assistance.

Shut down the engine

Shut down the engine before opening or removing the engine access panel/hood. Maintenance and service procedures should be carried out on a stopped engine unless otherwise specified.

Prevent an undesired start-up by removing the starting key and disconnecting the electricity with the main switch and locking it in the disconnected position. A warning notice should also be placed at the operating station advising that work is being carried out.

Working with or getting close to a running engine is a safety risk. Hair, fingers, loose-fitting clothing or a dropped tool can get caught in rotating parts causing severe injury. Volvo Penta recommends that all service work that requires that the engine be running be assigned to an authorized Volvo Penta repair facility.

Safety instructions for operation and maintenance (cont.)

Lifting the engine

When lifting the engine use the lifting eyes that are mounted on the engine. Always make sure that the lifting device is in good condition and has sufficient capacity for the lift (the weight of the engine as well as all necessary extra equipment). For safe handling the engine should be lifted with an adjustable lifting boom. All chains or cables should run parallel to each other and as possible at right angles to the upper surface of the engine. Note that extra equipment that is mounted on the engine can change its center of gravity. Special lifting equipment may be necessary to insure correct balance and safe handling. Never perform work on a motor that is only hanging in a lifting device.

Before starting

Replace all protective covers that have been removed prior to starting the engine. Make sure that no tools or other objects have been left near the engine.

An engine with a turbocharger may never be started without the air filter being mounted. The rotating compressor wheel in the turbo can cause severe injuries. There is also a risk that foreign objects can be sucked in causing damage to the machine.

Fire and explosion

Fuel and lubricating oil

All fuels, most lubricating substances and many chemicals are flammable. Always read and follow all instructions listed on the packaging.

Work on the fuel system must be performed on a cold engine. Fuel leakage and spillage onto hot surfaces or electrical components can cause a fire.

Store oil and fuel-soaked rags and other flammable material in a fire-safe manner. Oil-soaked rags can spontaneously ignite under certain conditions.

Never smoke while filling with fuel or lubricating oil, in proximity to the filling station or in the engine compartment.

Non-original parts

Components of the fuel and electrical systems on Volvo Penta engines are designed and manufactured to minimize the risk of explosion or fire according to applicable requirements.

Use of non-original parts can result in explosion or fire.

Batteries

Batteries contain and develop oxyhydrogen gas, especially while charging. Oxyhydrogen gas is easily flammable and very explosive.

Smoking, open fire or sparks must never be allowed near batteries or the battery compartment.

An improper connection of a battery cable or booster cable can cause a spark that can in turn cause the battery to explode.

Starting fluid

Never use starting spray or other similar substances to help start an engine with air pre-heating (glow plugs/starting coil). This could cause an explosion in the intake tract. This poses a risk of injury.

Hot surfaces and fluids

A warm engine always creates a risk for burns. Be careful of hot surfaces. For example: exhaust pipes, turbo, oil sump, turbo pressure pipe, heating coil, hot coolant and warm lubricating oil in lines and hoses.

Chemicals

Most chemicals, for example glycol, rust prevention substances, preserving oils, degreasers, etc. are hazardous to your health. Always read and follow the directions on the packaging.

Certain chemicals, for example preserving oils are flammable and also hazardous if inhaled. Make sure that you have good ventilation and use a protective mask when spraying. Always read and follow the directions on the packaging.

Keep chemicals and other hazardous materials out of reach of children. Bring leftover or used chemicals to an environmental station for destruction.

Lubrication system

Warm oil can cause burns. Avoid skin contact with warm oil. Make sure that the lubrication system is not pressurized prior to performing service. Never start or operate the engine without the oil filler cap in place due to risk of oil being thrown out.

Cooling system

Avoid opening the coolant filler cap when the engine is warm. Steam or hot coolant can squirt out causing burns.

If the filler cap, coolant lines, taps or so on must be opened or removed while the motor is warm the filler cap must be opened slowly and carefully so that pressure is released before the cap is completely removed and work is started. Note that the coolant can still be hot and cause burns.

Fuel system

Always protect your hands when searching for leaks. Streaming pressurized liquids can make their way into body tissues causing serious injuries. There is a risk of blood poisoning.

Always cover the generator if it is placed under the fuel filter. A fuel spill can damage the generator.

Electrical system

Disconnect the power

Before servicing the electrical system the engine should be stopped and the electrical power switched off using the main switch/breakers. External power to the engine heater, battery charger or other equipment mounted on the engine must be switched off.

Batteries

Batteries contain a very strong corrosive electrolyte. Protect your eyes, skin and clothing during charging or other handling of batteries. Always use safety glasses and gloves.

In case of skin contact, wash with soap and large quantities of water. In case of eye contact rinse immediately with large quantities of water and contact a doctor as soon as possible.

Electric welding

Remove the positive and negative cables from the batteries. Next, remove all connections to the generator.

Always connect the welding clamp to the component to be welded and as close to the place to be welded as possible. The clamp must never be attached to the engine or so that the current can pass through any bearings.

When finished welding: Always connect all connections to the generator **before** the battery cables are reconnected.

Introduction

This instruction book has been compiled to give you the best possible use of your Volvo Penta industrial engine. It contains the information you need to operate and take care of the engine in a safe and correct manner. We therefore ask you to read the instruction book carefully and to learn to handle the engine, controls and additional equipment in a safe manner before you start the engine.

⚠ IMPORTANT! The instruction book describes the engine and equipment that are sold by Volvo Penta. In certain applications there can be variations of for example controls and instrumentation that concern both appearance and function. In these cases we refer you to the instruction book for the application in question.

Environmental care

We all want to live in a pure and healthy environment where we can breathe fresh air, see healthy trees, have clean water in our lakes and oceans and where we can enjoy the sunshine without fearing for our health. Unfortunately this is not always the case today but it is a situation that we all must work to preserve and protect.

As an engine manufacturer Volvo Penta has a special responsibility, therefore care for the environment is a core value in our product development. Today Volvo Penta has a broad engine line where large steps have been taken towards reducing exhaust emissions and improving fuel economy, engine noise and so on.

We hope that you will be careful to preserve these qualities. Always follow the advice in the instruction book regarding fuel quality, operation and maintenance so that you can avoid unnecessary damage to the environment. Contact your Volvo Penta dealer if you notice changes such as decreased fuel economy or increased exhaust smoke.

Remember to always bring hazardous waste such as drained oil, coolant, used batteries etc. to an environmental station for destruction.

Through our mutual efforts we can make a valuable contribution to the environment.

Running-in

The engine should be "run-in" during the first 10 hours of operation according to the following: Run the engine as with normal operation. Full-throttle operation should not occur for more than short periods. Do not run the engine for long periods of time at steady RPM during the run-in period.

An increase in the consumption of lubricating oil is normal during the first 100–200 hours of operation. It is therefore important to check the oil level more often than is normally recommended.

When a clutch is mounted it should be inspected more frequently during the first days of operation. Adjustment may be required to compensate for initial wear of the plates.

Fuel and oils

Only use fuel and oils of a grade matching that recommended in the instruction book (see the chapter on "Maintenance" under the fuel and lubricating system headings). Other grades can cause problems with operation, decreased fuel economy and in the long run even a shortened lifetime of the engine.

Always change the oil, oil and fuel filters according to the prescribed intervals.

Maintenance and replacement parts

Volvo Penta engines are constructed for maximal dependability and longevity. They are built to survive in demanding environments but also to have the minimum possible impact on the environment within which they operate. Regular maintenance and use of Volvo Penta original parts will preserve these properties.

Volvo Penta has a worldwide network of authorized dealers. They are specialists on Volvo Penta products and have accessories, original parts, test equipment and the special tools that are necessary for high-quality service and repair work.

Always adhere to the maintenance schedules listed in the instruction book and remember to provide the engine/transmission identification number when ordering service and parts.

Certified engines

For those of you who own an emissions-certified engine that is used in an area where exhaust emissions are legally regulated, it is important to recognize the following:

A certification signifies that an engine type has been inspected and approved by the authorities in question. The manufacturer of the engine guarantees that all engines of the same type will match the engine that was certified.

This places the following special requirements upon the maintenance and service that you perform on your engine:

- Maintenance and service intervals recommended by Volvo Penta must be followed.
- Only Volvo Penta original parts may be used.
- Service on the injector pumps, pump settings and injectors must always be performed by an authorized Volvo Penta repair facility.

- The engine may not be rebuilt or modified with the exception of accessories and service kits developed by Volvo Penta for the engine.
- No changes may be made to the engine's exhaust or intake air systems.
- No seals may be broken by non-authorized personnel.

In all other cases follow the advice in the instruction book regarding operation, maintenance and service.

 **IMPORTANT!** In cases of neglected or deficient maintenance/service as well as use of non-original parts AB Volvo Penta will no longer be able to assure that the engine meets conditions of certification. Volvo Penta will not settle damages and/or costs associated with such instances.

Warranty

Your new Volvo Penta industrial engine is covered by a limited warranty according to the conditions and instructions that are contained in the Warranty and Service book.

Note that AB Volvo Penta's responsibility is limited to that which is named in the Warranty and Service book. Read it carefully immediately following delivery. It contains vital information on subjects such as the warranty card, services, and maintenance that is your responsibility as the owner to be aware of, check on and perform. AB Volvo Penta may otherwise completely or partially deny warranty claims.

Contact your Volvo Penta dealer if you do not have a Warranty and Service book as well as a customer copy of the warranty card.

Presentation

TAD1240GE, TAD1241GE/VE, TAD1242GE/VE and TWD1240VE are inline, direct-injected, 6-cylinder industrial diesel engines.

They are equipped with electronically controlled fuel management, turbochargers, intercoolers and thermostatically regulated cooling systems and electronic RPM regulation.

Technical description

Engine and cylinder block

- Cylinder block and cylinder head of alloyed cast iron
- Seven main bearing induction hardened crankshaft
- Wet replaceable cylinder liners
- Cast aluminum pistons with oil cooling
- Three piston rings, the top of which is of the "keystone" variety
- Induction hardened overhead camshaft with roller rocker arms
- Four valves per cylinder
- Replaceable valve seats and valve guides

Fuel system

- Microprocessor-based control unit for fuel delivery (EDCIII)*
- Gear-driven feeder pump
- Centrally placed unit injector with electromagnetically controlled fuel valves
- Fuel filter of spin-on type and a water separating filter

Lubrication system

- Water-cooled oil cooler
- Gear-driven oil pump
- Full flow and bypass oil filters of spin-on type

Intake air compression system

- Turbocharger

Cooling system

- Cooler with expansion tank
- Water-cooled line-type intercooler (TWD)
Air-cooled intercooler (TAD)

Electrical system

- 24V electric system with generator (60A) with charging sensor

TAD

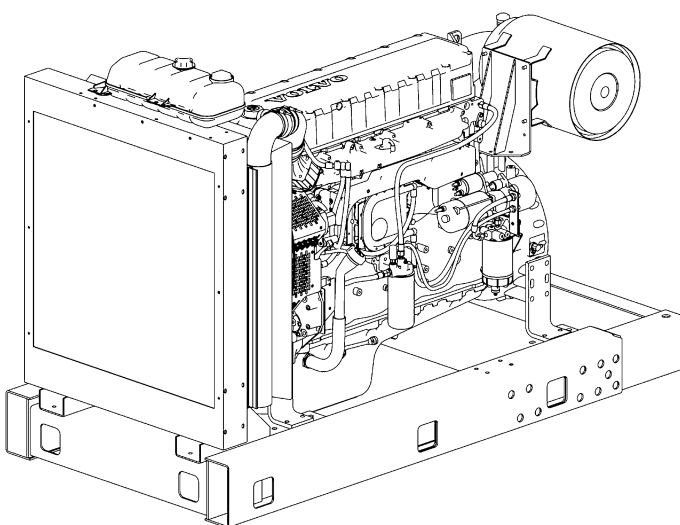

TWD

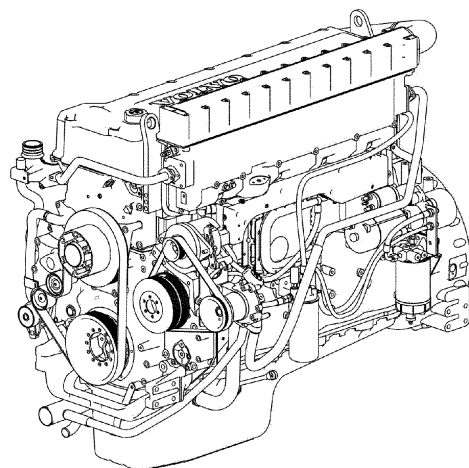

* EDC III ("Electronic Diesel Control"), see separate description.

Identification numbers

Location of engine plates

The plate below shows:

- 1 Engine designation
- 2 Serial number
- 3 Specification number

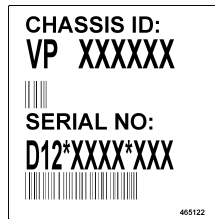

The plate below shows:

- 1 Engine designation
- 2 Specification number
- 3 Serial number engine block (last six digits)

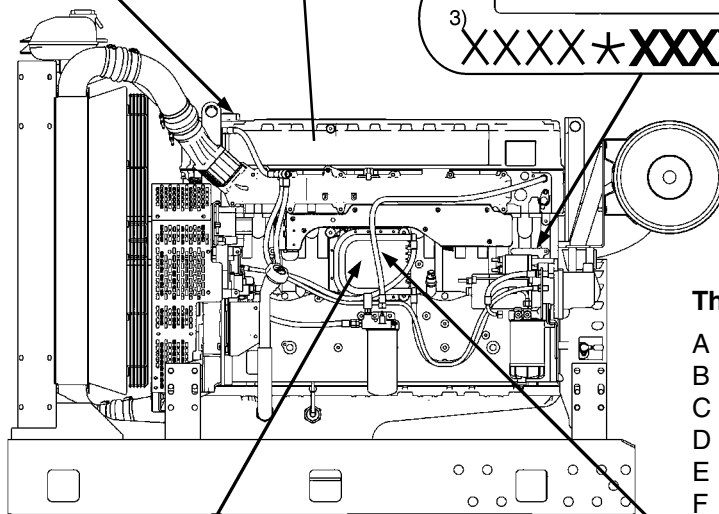
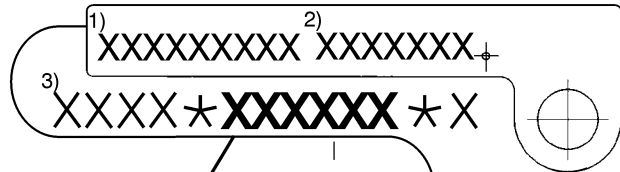

The plate below shows:

- A Engine designation
- B Net engine output (without fan)
- C Max. rpm
- D Main software
- E Computer kit number
- F Product number

IMPORTANT ENGINE INFORMATION			
VOLVO PENTA		AB Volvo Penta, Sweden	
ENGINE FAMILY: K	DISPLACEMENT: J	VALVE LASH INT.: F1	
ENGINE MODEL: A	EXHAUST EMISSION: F2	CONT. SYST. EM. TC.: I	CONSTANT SPEED C
ENGINE CODE: B	POWER: C	FUEL RATE: D	STATIC TIMING: G
<small>USA THIS ENGINE CONFORMS TO 2004 U.S. EPA REGULATIONS LARGE NON ROAD COMPRESSION-IGNITION ENGINES. THIS ENGINE IS CERTIFIED TO OPERATE ON DIESEL FUEL ONLY.</small>			
<small>CALIFORNIA THIS ENGINE CONFORMS TO 2004 CALIFORNIA REGULATIONS FOR HEAVY-DUTY OFF-ROAD DIESEL CYCLE ENGINES AS APPLICABLE. THIS ENGINE IS CERTIFIED TO OPERATE ON DIESEL FUEL ONLY.</small>			

VOLVO PENTA	
	A
RATED POWER:	B
RATED SPEED:	C
MSW:	D
DST1:	E
DST2:	E
SPEC. NO.	F

The above plate shows:

- (K) Engine family
- (J) Swept volume
- (A) Engine designation
- (F1) Valve clearance, inlet
- (F2) Valve clearance, outlet
- (I) Emission Control devices
- (P) Only constant RPM
- (E) Part number – decal
- (B) Engine code (in engine family)
- (C) Output/RPM
- (D) Fuel quantity
- (M) Engine speed
- (H) Certification approval number (EU)

Explanation of engine designation:

Ex. TAD1240GE/TWD1240VE

- T – Turbo
- A – Air-to-air Charge air cooler
- W – Water to air, intercooler
- D – Diesel engine
- 12 – Swept volume, liter
- 4 – Generation
- 0 – Version
- G – Gen Set engine
- V – Stationary and mobile operation
- E – Emissions check

Orientation

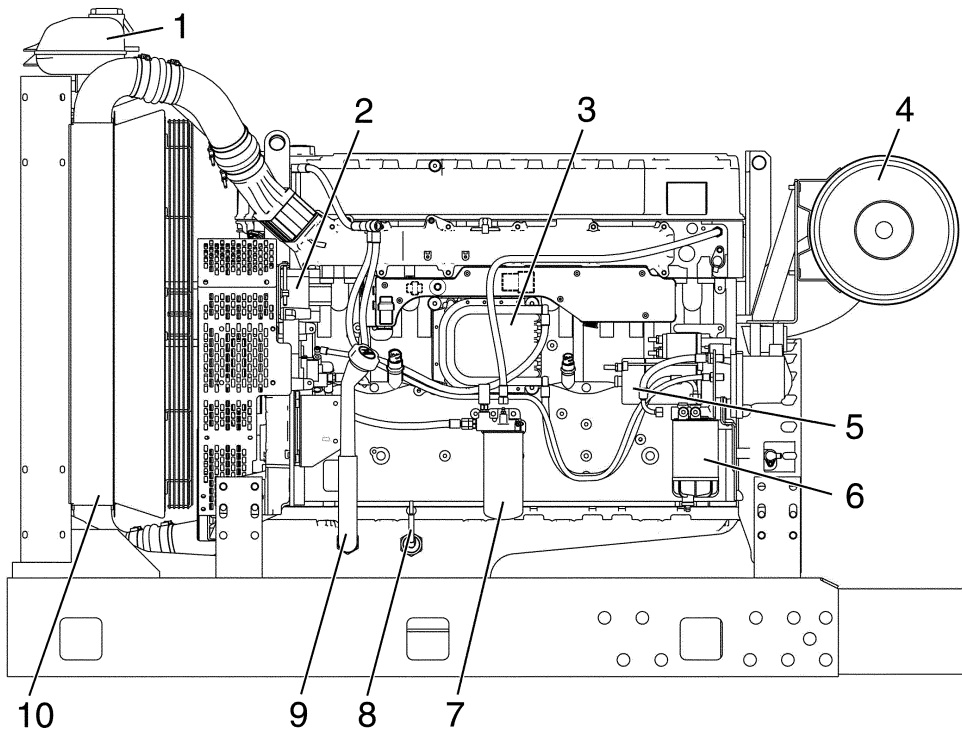

The picture shows TAD1240GE, TAD1241GE and TAD1242GE variants.

1. Expansion tank
2. AC generator
3. Control unit
4. Air filter
5. Starter motor
6. Fuel pre-filter with water sensor
7. Fuel filter with fuel pressure sensor
8. Oil dipstick
9. Oil filler
10. Intercooler (TAD only)

EDC III

EDC III stands for "Electronic Diesel Control" and is an electronic system with CAN (Controller Area Network) communication for diesel engine management. The system was developed by Volvo Penta and includes such parameters as fuel management and diagnostic functions.

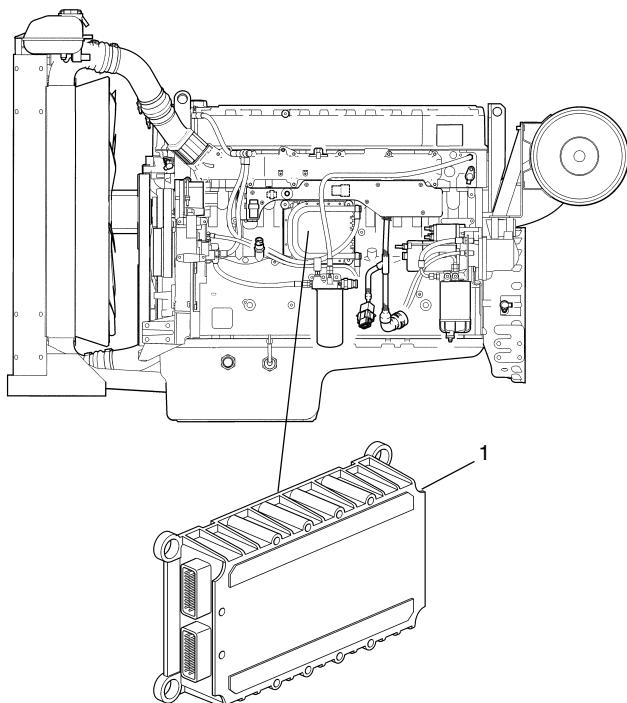

Control unit (1)

The EDC III system's processor is located in the control unit, protected from moisture and vibrations.

The processor continually receives information regarding:

- rpm levels
- intake boost pressure
- intake temperature
- coolant temperature
- oil pressure
- oil temperature
- fuel alarm, includes both "water in fuel" as well as "fuel pressure"
- coolant level

The information provides a precise overview of current operational conditions making it possible for the processor to do such things as determine the correct fuel dosage and check on the engine's condition.

Fuel management

The fuel needs of the engine are analyzed up to 100 times per second. Fuel injection quantity and timing are controlled electronically via fuel valves in the unit injectors.

This means that the engine always receives the correct amount of fuel under all operating conditions, providing benefits including improved fuel economy and minimized exhaust emissions.

Diagnostic function

The diagnostic system's function is to detect and localize disturbances within the EDC III system, to protect the engine as well as to insure the ability to control the engine during serious disturbances.

If a disturbance is detected a diagnostic indicator in the control panel will begin to blink. Pushing the diagnosis button will provide the operator with an error code to assist in locating the problem.

Instrument, EDC III

NOTE! All instruments are accessories.

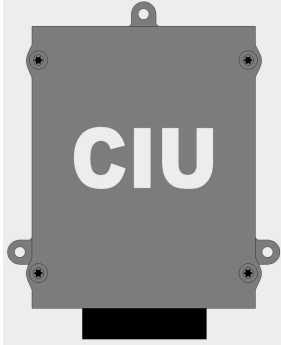

CIU - Control Interface Unit

The CIU is the “translator” between the control unit and the customer’s own control panel. The CIU has two serial communication links, a fast one and a slow one.

The fast one is a so-called CAN link. All data related to instruments, indication lamps, connectors and potentiometers is controlled by this link.

The slow link manages diagnostic information for flashing codes etc.

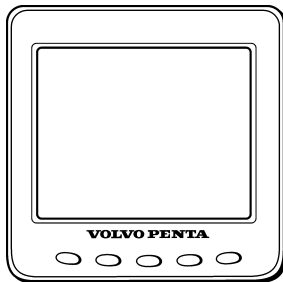

DU - Display Unit

The DU is an instrument panel which shows engine working values graphically on an LCD screen. It consists of a computerised unit for permanent installation in a control panel.

The DU is connected between the engine control unit and the CIU or DCU.

Easy Link instrument (only together with a CIU)

The following “Easy Link” instruments are available:

- Engine speed / hours counter (fault codes are also displayed on the tachometer display when the diagnostic button is pressed)
- Coolant temperature
- Oil pressure
- Oil temperature
- Battery voltage
- Alarm panel
- Turbo pressure

DCU (Display Control Unit)

The DCU (Diesel Control System) control panel is available as an optional accessory for the EMS (Engine Management System) electronic control system. The DCU is a digital instrument panel which communicates with the engine control unit. DCU has several functions, such as: engine control, monitoring, diagnostics and parameter setting.

The menus in the DCU system can be used to check, and in some cases to set a number of different functions in the EMS system.

NOTE! The menus and illustrations shown here are the English version. The language can be changed, however. Please refer to the “Setup” menu.

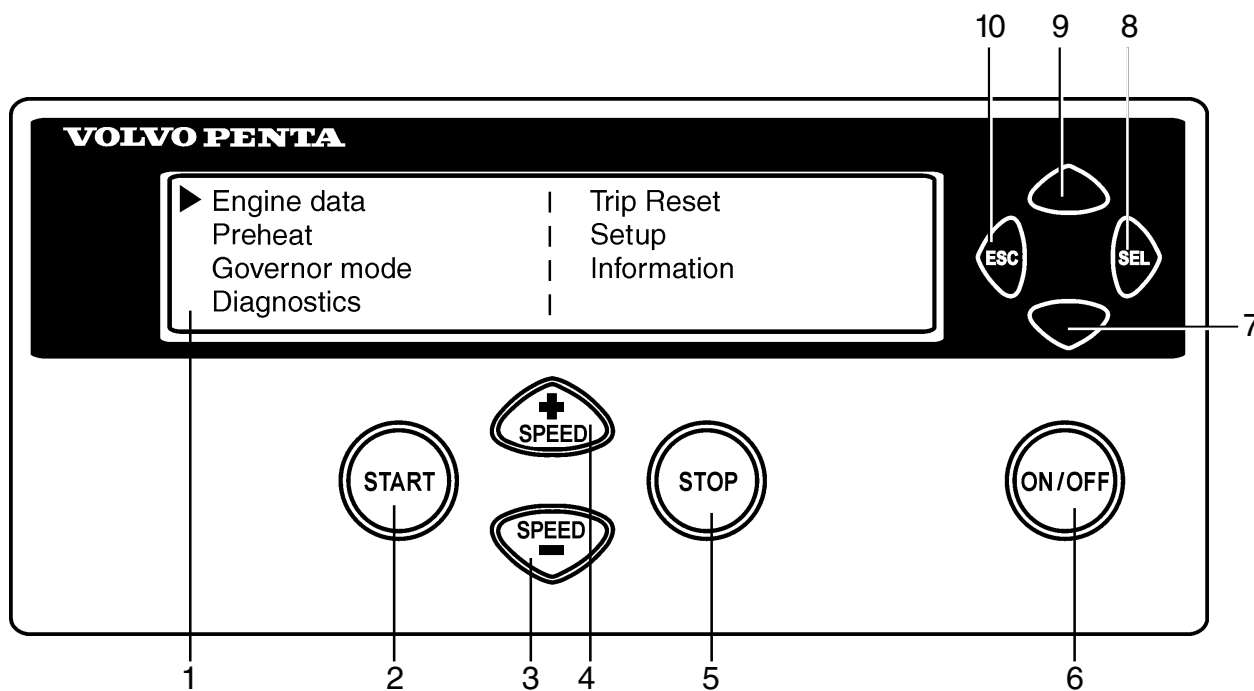

- | | |
|------------------------------------|--------------------------------------------|
| 1. LED display | 6. ON/OFF. Starts and stops the system |
| 2. START. Starts the engine | 7. Scroll downwards in menus |
| 3. SPEED -. Reduces engine speed | 8. SEL. Selects in menu |
| 4. SPEED +. Increases engine speed | 9. Scroll upwards in menus |
| 5. STOP. Stops the engine | 10. ESC. Return to previous menu selection |

Start

When the DCU panel is started up, the “Engine Data” menu is displayed. Press “ESC” to come to the main menu.

Menus

There are several sub-menus under each main menu. There is not space for all the menu choices on the display. To scroll through the menus, use the “7” and “9” buttons on the display. Press the “SEL” button, no. “8” to make a selection. Please refer to the illustration on the previous page.

NOTE! The “Setup” menu can be used to select the language that you want to use on the display.

▶ Engine data		Trip Reset
Preheat		Setup
Governor mode		Information
Diagnostics		

Main menu

- **Engine data**, relevant engine data.
- **Preheat**, manual activation of pre-heating
- **Governor mode**, activation of droop.
- **Diagnostics**, shows fault codes in plain language.
- **Trip reset**, resets trip data
- **Setup**, parameter setting
- **Information**, shows the data for the applicable hardware, software, data set and engine identification of the engine and DCU

▶ Eng speed	rpm		Boost prs	kPa
Cool temp	C		Boost tmp	C
Oil pres	kPa		Oil temp	C
Eng hours	h		Batt Volt	V

Engine data

shows relevant engine data.

- Engine speed, can be controlled with the “SPEED +” and “SPEED –” buttons (rpm)
- Charge pressure (kPa)
- Coolant temperature (°C)
- Charge air temperature (°C)
- Oil pressure (kPa)
- Oil temperature (°C)
- Engine hours (h)
- Battery voltage (V)
- Fuel consumption (l/h)
- Instantaneous fuel consumption (trip fuel) (l)

*** Preheat ***
Press SEL to request preheat

Preheat

manual activation of pre-heating. When it is activated, the EMS system senses when started if pre-heating is needed. For automatic pre-heating, please refer to the "Setup" / "Pre-heat on ignition" menu.

The pre-heating time is adjusted to suit the engine temperature, and can last for up to 50 seconds both before and after starting. Also refer to "Starting procedure, EMS 2".

- Press "SEL", the text "Preheat requested" is displayed.
- The display automatically returns to the "Engine Data" menu.

*** Governor mode ***
Droop mode

Governor mode

activates/shuts off droop. To set the droop level, please refer to the "Setup" / "Governor gradient" or "Governor droop" menus.

- Select "Isochronous mode" or "Droop mode" with the SEL button.

*** Diagnostics 7/9 ***
20.0 h Engine oil pressure
signal failure Inactive

Diagnostics

shows the error list containing the 10 latest active and inactive faults. The fault code are shown as text on the display.

- Scroll through the error list with the arrow keys.

*** Trip Data Reset ***
Press SEL to reset trip data

Trip reset

resets trip data, such as fuel consumption.

- Press the SEL button to reset trip data.

Setup	
► Set Application :	(Versatile)
Units :	(Metric)
Language :	(English)

Setup

parameter setting in the engine’s control systems. Different menus appear under “Customer parameter”, depending on whether you select “Versatile” or “Genset” from “Set application”.

The parameters that can be set / selected (choice is made with the SEL button) are:

- **Set application**, setting of “Versatile” or “Genset”. Different menus appear under “Customer parameter”, depending on what is chosen here.
- **Unit**, selection of units of measurement (metric or US units)
- **Language**, selection of the language shown in the display. You can choose between English, French, German and Spanish.
- **Stop energized to**, setting for the external stop input. Activated at “Stop” or “Run”.
“Stop”: The stop input must be connected to voltage to stop the engine.
“Run”: The stop input must be connected to voltage to run the engine.
- **Customer parameter**, alarm limit setting. Please refer to “Customer parameter / Versatile” and “Customer parameter / Genset”.
- **Throttle input setting**, setting of speed control and voltage limits. See “Throttle input setting”.
- **Display setting**, display setting. See “Display setting”.

Setup (Versatile)	
► Idle engine speed :	rpm
Preheat on ignition :	
Governor gradient :	Nm/rpm

Customer parameter / Versatile

- **Idle engine speed** - setting idling speed
- **Preheat on ignition** - activation of automatic preheating. The engine control system senses if preheating is needed and activates it directly when switched on.
- **Governor gradient (Nm/rpm)** - setting the droop level, when this has been activated. Please refer to “Governor droop” in the main menu for activation.
- **Oil temp warning limit (°C)** - setting the alarm limit for the oil temperature.
- **Coolant temp warning limit (°C)** - setting the alarm limit for the coolant temperature.

Setup (Genset)	
▶ Primary engine speed	:
Preheat on ignition	:
Governor droop	:

Customer parameter / Genset

- **Primary engine speed** - selection of engine speed, 1500 or 1800 rpm.
- **Preheat on ignition** - activation of automatic pre-heating. The engine control system senses if pre-heating is needed and activates it directly when switched on.
- **Governor droop (%)** - setting the droop level, when this has been activated. Please refer to "Governor droop" in the main menu for activation.
- **Overspeed limit (%)** - setting the speed for the excess speed alarm, % of set engine speed.
- **Overspeed shutdown** - activation of engine shut down when the excess speed alarm is activated. Please refer to "Overspeed limit" to activate the alarm limit for the excess speed alarm.
- **Oil temp warning limit (°C)** - setting the alarm limit for the oil temperature.
- **Coolant temp limit (°C)** - setting the alarm limit for the coolant temperature.

Setup(Throttle)	
Setup throttle mode	: *** OFF ***

Setup(Throttle)	
▶ Set throttle mode	:
Set idle voltage	:
Set mx voltage	:

Throttle input setting

speed control setting (throttle operation).

- **Set throttle mode** -
 "OFF" - engine speed is controlled via the DCU panel.
 "ext throttle input" - engine speed is controlled with a potentiometer (accelerator).
 "ext voltage input" - engine speed is controlled by an external unit.
- **Set idle voltage (V)** - setting the voltage level at idle.
- **Set max voltage (V)** - setting the voltage level at maximum speed.

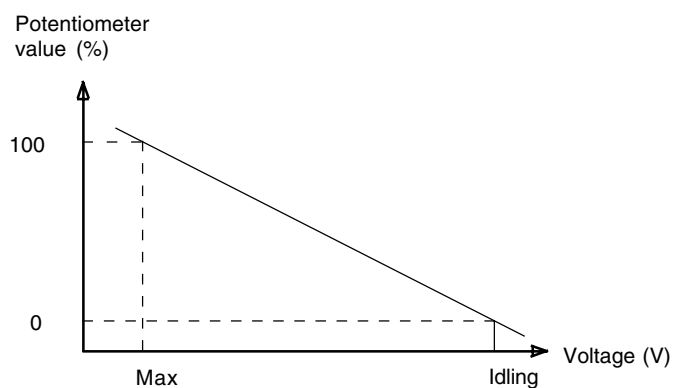
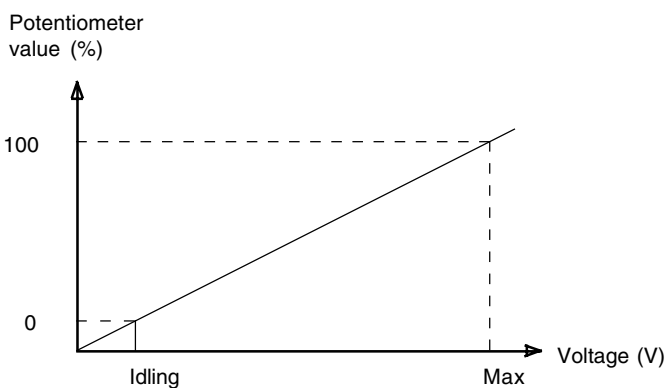

Setup (Display)		
▶ Set contrast	:	60%
Set backlighttime	:	5 sec
Set backlight brightness	:	10

Display setting

settings for the display. Adjustment is done with the “7” and “9” buttons, please refer to the DCU panel in the illustration.

- **Set contrast (%)** - display contrast adjustment.
- **Set backlight time (sec)** - sets the time (in seconds) for background illumination in the display. The light is then switched off if the panel is not used.
- **Set backlight brightness** - adjustment of illumination strength in the display.

*** Information ***	
▶ Engine hardware Id	:
Engine software Id	:
Engine Dataset1 Id	:

Information

shows the data for the engine and DCU.

- **Engine hardware ID** - part number of the engine control module
- **Engine software ID** - part number of the software in the engine control module
- **Engine dataset1 ID** - part number of engine data set 1.
- **Engine dataset2 ID** - part number of engine data set 2.
- **Vehicle ID** - chassis number
- **DCU hardware ID** - part number of the DCU.
- **DCU software ID** - part number of the software in the DCU.
- **DCU dataset1 ID** - part number of DCU data set 1.
- **DCU dataset2 ID** - part number of DCU data set 2.

Starting the engine

Make a habit of always visually checking the engine and engine compartment prior to starting the engine. This will help you to quickly notice if any abnormal conditions have occurred or are occurring. Check also to verify that the instruments show normal values after start-up.

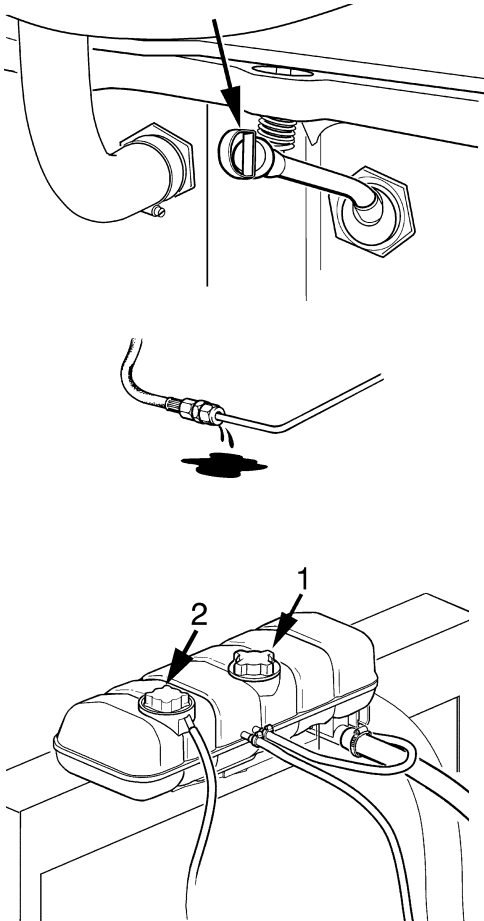

Before starting

- Check that the oil level is between the MIN and MAX marks. See the chapter "Maintenance, lubrication system".
- Open the fuelcocks.
- Make sure that there is no leakage of coolant, fuel or oil.
- Check the air filter's pressure drop indicator. See the chapter "Maintenance, Engine, general".
- Check the coolant levels and that the radiator is not blocked on the outside. See the chapter "Maintenance, cooling system".

⚠ WARNING! Do not open the coolant filler cap (1) when the engine is warm. Steam or hot coolant can squirt out

NOTE! Do not open the pressure cap (2).

- Turn on the main switches.

⚠ IMPORTANT! Never switch off the power with the main switch while the engine is running. The generator can be damaged.

- Set the throttle to idle and disengage the clutch/ put the transmission in neutral.

Starting method EMS 2

The pre-heating time is adjusted to suit the engine temperature, and can last for up to 50 seconds both before and after starting.

The starter motor connection time is maximized to 30 seconds. After that, the starter motor circuit is cut for 80 seconds to protect the starter motor against overheating.

NOTE! Preheating must be activated at temperatures below 0°.

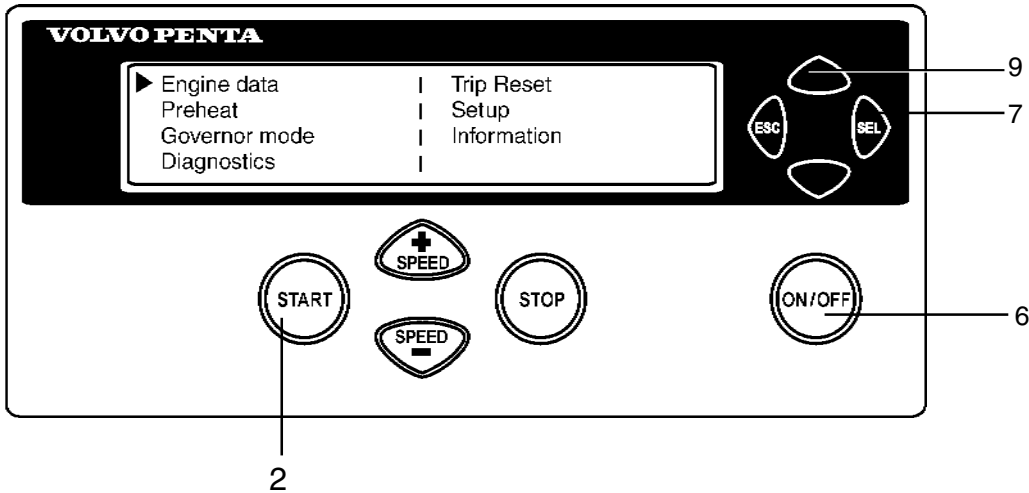

With pre-heating

1. Depress the "ON/OFF" button (6).
2. Press the "SEL" button (7) to come to the main menu.
3. Scroll down to **Preheat** with button (9). Press the "SEL" button (7).
4. In the pre-heat menu, press the "SEL" button (7) to select pre-heating. The text "Preheat active please wait" is shown in the display.
5. Wait until the text has gone out and then press the "START" button (2).

Without pre-heating

1. Depress the "ON/OFF" button (6).
2. Press the "START" button (2).

Leave the engine to idle for the first 10 seconds. Then warm the engine up at low speed and under low load.

⚠ IMPORTANT! Never race the engine when it is cold.

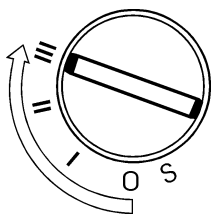

Volvo Penta start lock:

1. Turn the key to the "I" position and check the indicator lamps.
2. Position "II". Pre-heating is activated (pre-heating is an option). Wait until the pre-heating indicator lamp goes out. Pre-heating time is dependent upon engine temperature.
3. Start the engine with position "III". Let the key return to position "I" immediately once the engine has started.

NOTE! The engine has a built-in starter motor interlock to prevent inadvertent activation of the starter motor while the engine is running. The key must be turned to the "O" position before attempting to start again.

Let the engine run at 500–700 rpm for the first 10 seconds. Following this, warm up the engine using low rpm and low loading.

⚠ IMPORTANT! Never rev-up the engine when it is cold.

Alternative pre-heating:

1. Turn the key to the "I" position and check the indicator lamps. Pre-heating activates automatically (pre-heating is an option). Pre-heating time is dependent upon engine temperature.
2. Start the engine with position "III". Let the key return to position "I" immediately once the engine has started.

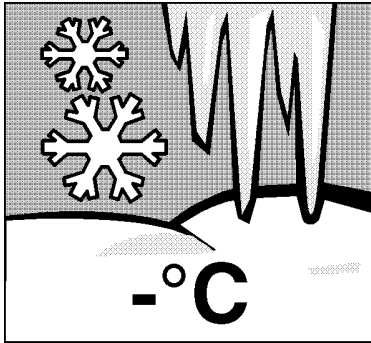

Start-up under extreme cold

To facilitate and in certain cases allow start-up under extremely cold conditions certain procedures must be followed:

Use a winter fuel (from a well-known supplier) that has been approved for the temperature in question. This minimizes the risk of wax precipitation in the fuel system. During extremely low temperatures use of a fuel heater is recommended.

In order to insure sufficient lubrication we recommend use of synthetic oil of the recommended viscosity for the temperature in question (see chapter "Maintenance, lubrication system"). Synthetic oils retain their lubricating properties over a wider range of temperatures than mineral oils.

Pre-heat the coolant by using a separately mounted electric engine heater. In extreme cases it can be necessary to use a diesel-powered engine heater. Consult your Volvo Penta dealer.

⚠ IMPORTANT! Make sure that the cooling system is filled with a glycol mixture. See the chapter "Maintenance, cooling system".

The batteries must be in good condition. Cold reduces the capacity of the batteries. Increasing the total battery capacity may be necessary.



Never use starting spray

- ⚠ WARNING!** Never use starting spray or other similar substances to help start an engine. This could cause an explosion in the intake tract. This poses a risk of injury.

Start with booster batteries

- ⚠ WARNING!** Batteries (especially booster batteries) contain oxyhydrogen gas that is very explosive. A spark, which can occur if the booster batteries are improperly connected, can be sufficient to cause a battery to explode causing damage and/or injury.

1. Make sure that the booster batteries are connected (in series or in parallel) so that the ground voltage corresponds to the engine's system voltage.
2. First connect the red booster cable (+) to the booster battery and then to the dead battery. Then connect the black booster cable (-) to the booster battery, then to a place that is **a distance away from the dead battery**, i.e. next to the main switch on the negative wiring or at the negative cable's connection to the starter motor.
3. Start the engine.

- ⚠ WARNING!** Do not disturb the connections while attempting to start the engine (risk for creating sparks) and do not lean over any of the batteries.

4. Remove the cables in reverse order.

- ⚠ WARNING!** The normal cables to the standard batteries must absolutely not be modified.

Operation

Correct operation technique is very important for both fuel economy and engine life. Always let the engine warm up to normal operating temperature before operating at full power. Avoid sudden throttle openings and operation at high engine speeds.

Checking instruments

Check all instruments directly after starting, and then regularly during operation.

IMPORTANT! On engines which operate continuously, the lubrication oil level must be checked, at least every **24 hours**. Please refer to the "Maintenance, lubrication system" chapter:

Fault indication

If the EMS 2 system receives abnormal signals from the engine, the control unit generates fault codes and alarms, in the form of lamps and audible warnings. This is done by means of CAN signals to the instrument.

More information about fault codes and fault tracing is found in the "Diagnostic function" chapter.

Operation at low load

Avoid long-term operation at idle or at low load, since this can lead to increased oil consumption and eventually to oil leakage from the exhaust manifold, since oil will seep past the turbocharger seals and accompany the induction air into the inlet manifold at low turbo boost pressure.

One consequence of this is that carbon builds up on valves, piston crowns, exhaust ports and the exhaust turbine.

At low load, the combustion temperature is so low that full combustion of the fuel can not be ensured, which means that the lubrication oil can be diluted by diesel fuel, and the exhaust manifold will eventually leak oil.

If the following points are done as a complement to normal maintenance, there will be no risk of malfunctions caused by operation at low load.

- Reduce operation at low load to a minimum. If the engine is regularly test run without load once a week, operation duration should be limited to 5 minutes.
- Run the engine at full load for about 4 hours once a year. Carbon deposits in the engine and exhaust pipe can then be burned off.

Stopping the engine

In case of extended time between uses the engine should be run until warm at least once every 14 days. This prevents corrosion of the engine. If the engine will not be used for more than two months preservation should be performed. See the chapter "Storage".

! IMPORTANT! In case of freezing temperatures liquid in the cooling system must have sufficient anti-freeze. See the chapter "Maintenance, cooling system". A poorly charged battery can freeze and break.

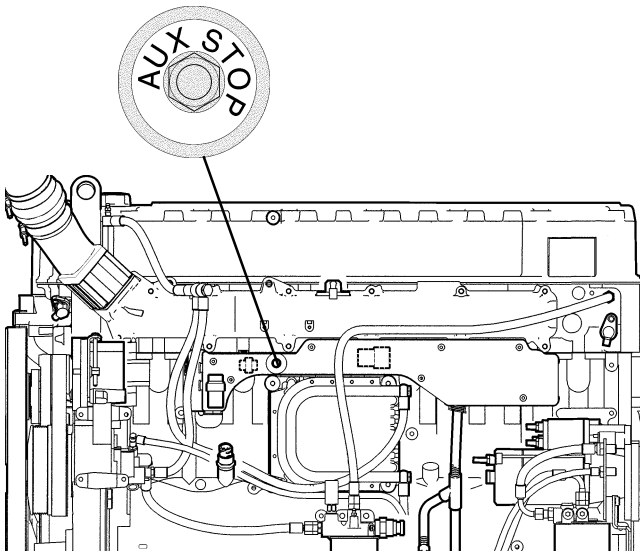
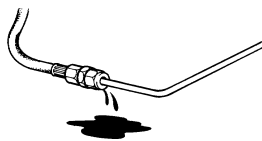
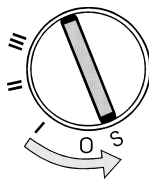
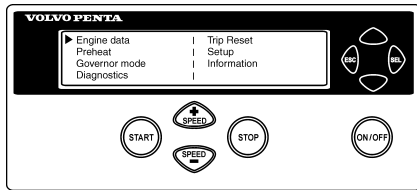

Before shut-down

Allow the engine to run a few minutes with no load before it is shut down. This permits an evening out of temperatures within the engine, which prevents "after-boiling" as well as cooling the turbocharger somewhat. This contributes to a lengthened useful life without disruptions.

Stop

- Disengage the clutch (if possible).
- Press the "STOP" button / turn the key to "S".

After shut-down

- Check the engine with respect to possible leakage.
- Switch off the main switch during extended periods without use.

Extra stop

The extra stop is on the engines left side, above the control unit.

! WARNING! Approaching or working on a running engine is a safety risk. Beware of rotating parts and hot surfaces.

Maintenance schedule

General

Your Volvo Penta engine and its equipment are built to provide a high degree of reliability and a long useful life. They are built to have the minimum possible effect upon the environment. Preventative maintenance according to the maintenance schedule and use of original Volvo Penta parts will preserve these qualities and help to avoid unnecessary operational disturbances.

MAINTENANCE SCHEDULE

⚠ WARNING! Prior to starting maintenance work the chapter "Maintenance" should be read carefully. In it you will find instructions for how the work can be carried out in a safe and correct manner

⚠ IMPORTANT! When both operational and calendar times are given maintenance should be performed in accordance with the first interval to arrive. Maintenance points marked with should be performed by an authorized Volvo Penta service facility.

Daily, before the first start-up

- Engine and engine compartment, general inspection page 28
- Air filter indicator, check ¹⁾ page 31
- Oil level, check and add page 33
- Coolant, check level page 37

¹⁾ Change the air filter at least every 12th month.

Every 50th operational hour / at least every 12th month

- Fuel filter. Drain water/impurities page 43

After the first 150 operational hours

- Engine oil, change ¹⁾ page 33

¹⁾ The oil change is recommended, the new engine oil should be one that is recommended by Volvo Penta

Every 50–600 operational hours / at least every 12th month

- Engine oil, change ¹⁾ page 33
- Oil filter/Bypass filter, change ²⁾ page 34

¹⁾ Oil change intervals will vary depending upon the grade of the oil and the amount of sulfur in the fuel. See page 26.

²⁾ The filter must be changed with every oil change.

Every 400th operational hour / at least every 12th month

- Fuel tank (sludge collector), drain. not shown
- Drive belts, check/adjust page 29-30
- Batteries, check electrolyte level page 46

Every 800th operational hour / at least every 12th month

- Charge air pipes, check for leaks page 28
- Fuel pre-filter, change filter element page 43
- Fuel filter, change page 42
- Fuel system, purging page 44
- Fuel pre-filter. Check not shown

Every 1000 operational hours / at least every 6th month

- Coolant filter, change ¹⁾ page 40

¹⁾ Not concurrent with the change of coolant.

Every 2000 operational hours

- Turbocharger, check not shown
- Valve play, check/adjust not shown

Every 12th month

- EDC system. Check with diagnosis tool not shown
- Engine, general check not shown
- Air filter element, change page 31
- Engine, cleaning/painting not shown
- Air Filter, tank ventilation, change. not shown
- Air filter, air compressor, change. not shown

Every 48th month or every 10,000 operational hours

- Cooling system, check/flush page 39
- Coolant, change pages 39-40

Newly rebuilt engine:**After the first 250 hours of operation**

- Valve play, adjust not shown

Maintenance

This chapter contains general technical information and instructions detailing how the recommended maintenance should be performed. Read carefully through the instructions before starting the task. The time frames for when each maintenance point should be performed are given in the previous chapter: Maintenance schedule.

⚠ WARNING! Read through the safety instructions for maintenance and service work in the chapter: Safety information, before starting to work.

⚠ WARNING! Maintenance and service work shall be performed on a stopped engine if not otherwise indicated. Stop the engine before the engine cover/hood is opened or removed. Make inadvertent start-up impossible by removing the starting key and disconnect the power using the main switch.

Engine, general

General inspection

Get in the habit of giving the engine and engine compartment a "visual" inspection **before starting the engine** and after operation **when the engine has stopped**. This will help you to quickly realize if something unusual has happened or is happening.

Look especially carefully for oil, fuel and coolant leakage, loose screws, worn or loose drive belts, loose connections or damaged hoses and wires. The inspection only takes a few minutes but can mean that serious service interruptions and costly repairs can be avoided.

⚠ WARNING! Puddles of fuel, oil or grease on the engine or in the engine compartment are a fire hazard and must be removed as soon as they are noticed.

⚠ IMPORTANT! If leakage of oil, fuel or coolant is detected the cause must be determined and the problem resolved before the engine is started.

⚠ IMPORTANT! When cleaning with a high-pressure sprayer the following instructions must be kept in mind: Never point the spray at seals, rubber hoses or electric components.

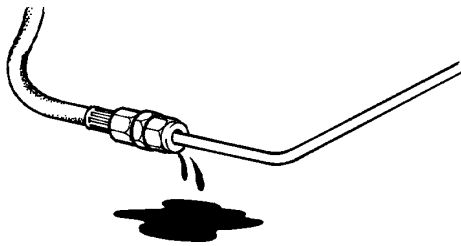

TAD

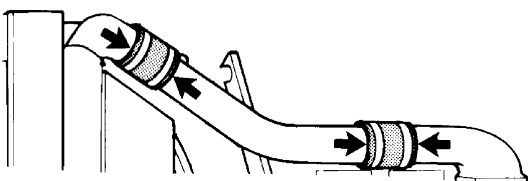

Charge air pipes, check

Check the condition of the charge air pipes and clamps looking for leaks or other damage. Change as needed.

Drive belts, check/adjust.

Check and adjustments should be done when the drive belts are warm.

The drive belt to the generator should be able to press in 3-4 mm between the drive belt pulleys.

The drive belt to the generator must be adjusted manually but the other drive belt is automatically adjusted. See "Drive belts, replacing". Check the drive belts for damage and wear. Replace when needed.

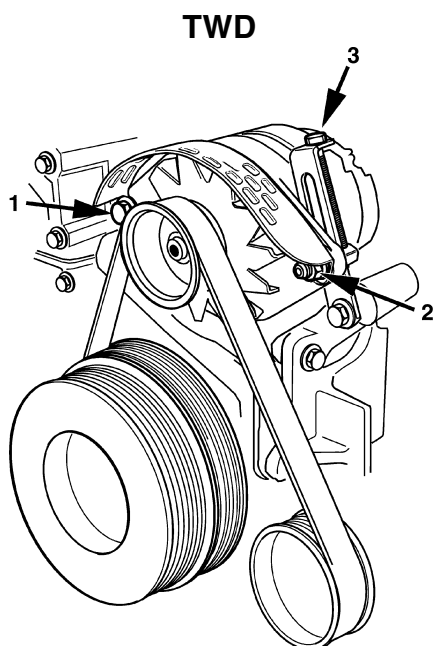
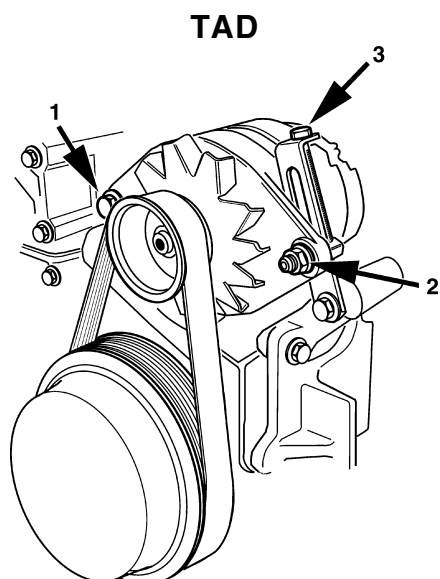

Generator belt, replacing

1. Switch the main switch/es off and make sure that the engine has no electrical power.
2. Remove the protective grill and the outer fan ring from around the cooling fan.
3. Remove the protective guards from around the drive belts.
4. Loosen the inner retaining screw (1) a couple of turns.
5. Loosen the lock screws (2) so that the tightening screws (3) can turn freely. Loosen the tightening screws and remove the drive belts.

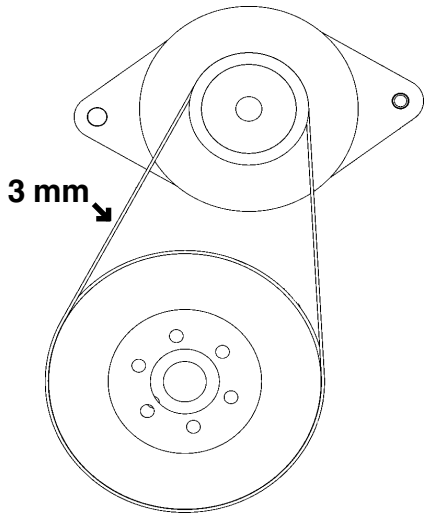

6. Mount the new drive belt and tighten it with the tightening screws (3). The play should be 3 mm for new belts and 3-4 mm for old belts. The play is measured where the drive belts are at their longest between pulleys. Tighten the inner retaining screw (1) and the lock screws (2).

⚠ IMPORTANT! ! Always change a belt that is worn or damaged.

NOTE! When the belt's tensioning mechanism is tightened additional tension is applied to the belt.

7. Replace the protective guards around the drive belts.
8. Replace the protective grill and the outer fan ring around the cooling fan.
8. Start the engine and perform a functional check.

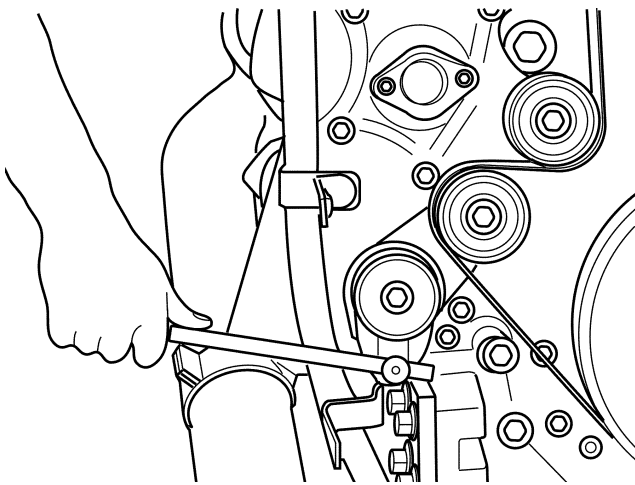

Drive belt, replacing

1. Switch the main switch/es off and make sure that the engine has no electrical power.
2. Remove the protective grill and the outer fan ring from around the cooling fan.
3. Remove the protective guards from around the drive belts.
4. Place a 1/2" wrench in the belt tensioner. Lift up the wrench and remove the drive belt.
5. Make sure that the pulleys are clean and undamaged.
6. Lift up the 1/2" wrench and mount the new drive belt.
7. Replace the protective guards around the drive belts.
8. Replace the protective grill and the outer fan ring around the cooling fan.
9. Start the engine and perform a functional check.

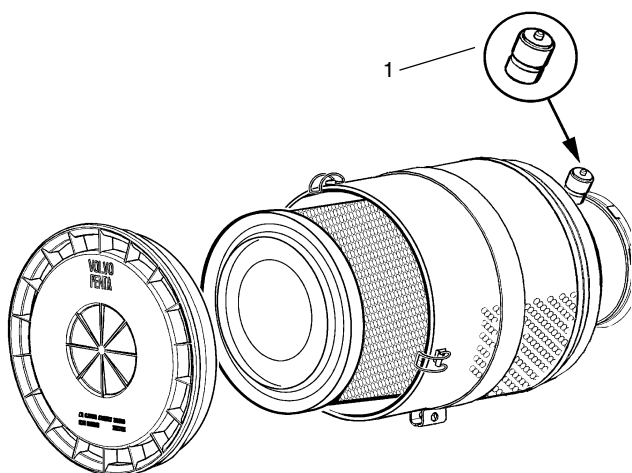

Air filter, check/replace

The air filter should be replaced when the indicator remains in the the red field when the engine has stopped. Reset the gauge (1) after replacing the indicator by prssing the button.

NOTE! The filter should not be touched before the indicator is in the red. Dispose of the old filter. It may not be cleaned or reused.

⚠ IMPORTANT! Under continuous operation the filter should be checked every 8 hours. For operation in extremely dirty environments such as coal mines and stone crushers a special filter is available (not sold by Volvo Penta).

Lubrication system

Oil change intervals can vary between 50–600 hours depending upon the grade of the oil and the sulfur content of the fuel. **Note that the oil change intervals may never exceed a period of 12 months.**

If change intervals longer than those provided are desired, the condition of the oil must be checked by the manufacturer of the oil by regular testing.

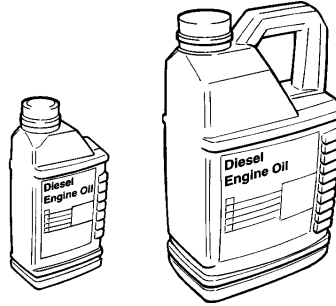

Oilgrade	Sulfur content in fuel, by weight		
	< 0,5 %	0,5 – 1,0 %	> 1,0 % ¹⁾
	Oil change interval, reached first in operation		
VDS-3 VDS-2 and ACEA: E7 ²⁾ VDS-2 and ACEA: E5 ²⁾ VDS-2 and Global DHD-1 ²⁾ VDS-2 and API: CI-4 ²⁾ VDS-2 and API: CH-4 ²⁾	600 h / 12 months	300 h / 12 months	150 h / 12 months
VDS and ACEA: E3 ²⁾	400 h / 12 months	200 h / 12 months	100 h / 12 months
ACEA: E7, E5, E4 API: CI-4, CH-4, CG-4	200 h / 12 months	100 h / 12 months	50 h / 12 months

NOTE! Mineral based oil, either fully or semi-synthetic, can be used on condition that it complies with the quality requirements above.

¹⁾ If the sulfur content is > 1.0% by weight, use oil with TBN > 15

²⁾ The engine oil must fulfill **both** requirements. For markets outside Europe, API: CG-4 and CH-4 can be used instead of ACEA: E3.

VDS = Volvo Drain Specification

ACEA = Association des Constructeurs Européenne d'Automobiles

API = American Petroleum Institute

Global DHD = Global Diesel Heavy Duty

TBN = Total Base Number

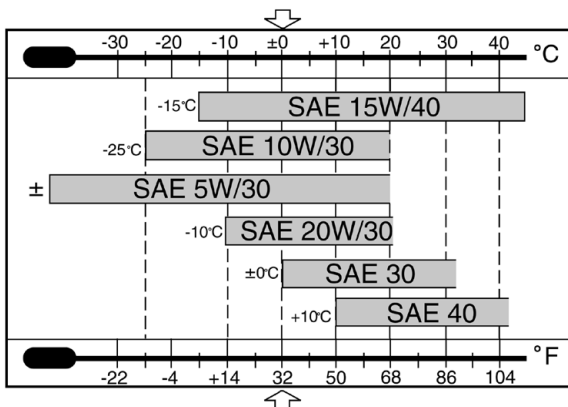

Viscosity

Viscosity should be chosen using the adjoining table. **Note:** The temperature values refer to steady outside air temperature.

* Refers to synthetic or partially synthetic oil

Oil change amount

See chapter "Technical Data".

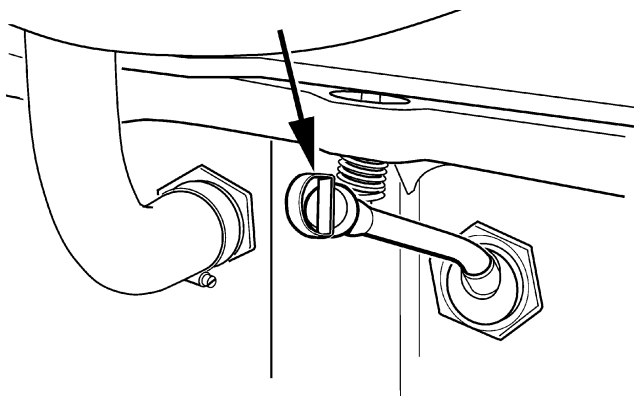

Oil level, check and add

The oil level should be within the marked area on the dipstick and should be checked daily before the first start.

Add oil using the filler opening on the side of the engine.

Check that the correct level is reached. Wait a few minutes so that the oil has time to run down into the oil pan.

⚠ IMPORTANT! Do not fill over the maximum oil level. Only use oil of the recommended grade (see previous page).

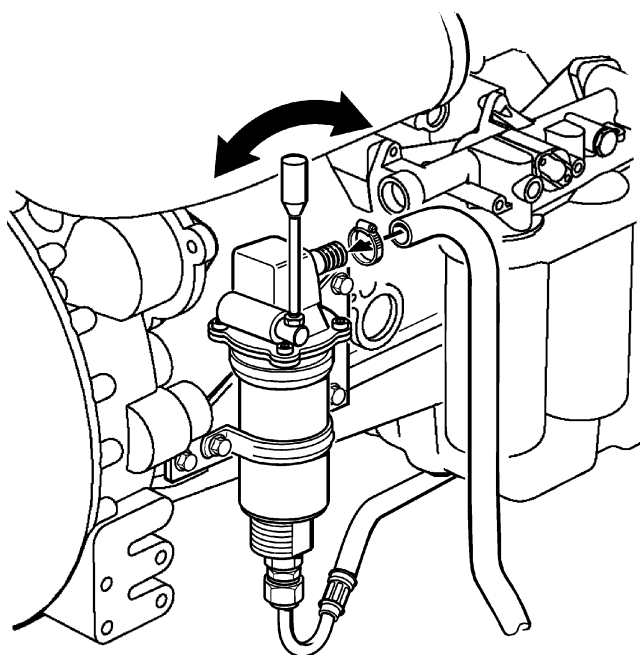

Engine oil, change

⚠ WARNING! Hot oil can cause severe burns.

NOTE! Oil should be changed while the engine is warm.

1. Connect the drain hose to the oil bilge pump and make sure that leakage can not occur.
2. Pump out the oil (or remove the drain plug and drain the oil).

NOTE! Collect all the used oil and deliver it to a used oil collection facility.

3. Remove the drain hose (or replace the drain plug).
4. Fill with new oil.

The volume of oil including changing three filters for a horizontally installed engine with a standard oil pan is 35 liters.

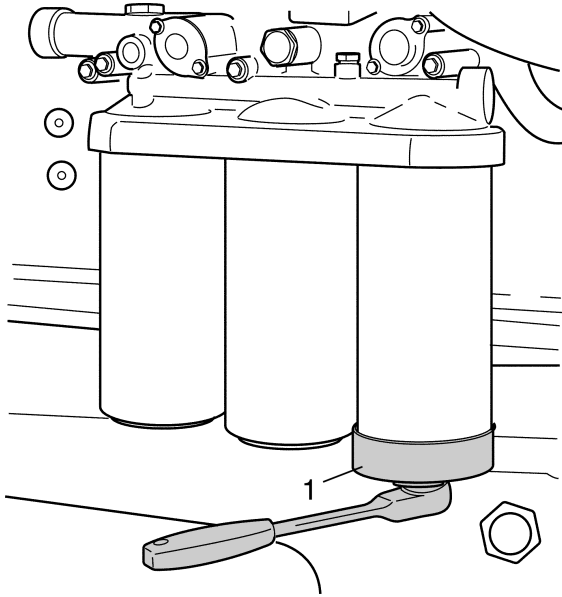

Oil filter/Bypass filter, change

⚠ WARNING! Hot oil can cause severe burns.

1. Clean the oil filter housing.
2. Remove all oil filters using appropriate filter wrenches (1).
3. Clean the sealing surface on the filter housing, making sure that no gasket residue remains.
4. Spread a thin layer of engine oil on the new filter's sealing rings.
5. Install the new oil filter. The two full-flow filters should be tightened 1/2 to 3/4 turn following seal contact. The bypass filter should be tightened 3/4 to 1 turn following seal contact.
6. Fill with oil, start the engine and operate it for 20-30 seconds.
7. Shut off the engine, check the oil level and fill with oil as needed.
8. Check the seals around the oil filters.

Cooling system

The cooling system ensures that the engine operates at the correct temperature. It is a closed circuit system and must always be filled with a mixture of at least 40 % concentrated coolant and 60 % water to protect against internal corrosion, cavitation and damage caused by freezing.

We recommend that you use “**Volvo Penta Coolant, Ready Mixed**”, alternatively “**Volvo Penta Coolant**” (concentrated) mixed with **pure** water according to spec, see “Coolant. Mixture”. Only coolant of this quality is suited too and approved by Volvo Penta.

The coolant should contain ethylene glycol of a good quality with a suitable chemical consistency for an adequate protection of the engine. Using anti-corrosion additive exclusively is not permitted in Volvo Penta’s engines. Never use water by itself as coolant.

⚠ IMPORTANT! Coolant, with a suitable consistency, must be used all year round. This applies even if there is never any risk for frost, to ensure that the engine has an adequate protection against corrosion. Future warranty claims on the engine and additional equipment may be rejected if an unsuitable coolant has been used or if the instructions concerning coolant mixing have not been followed.

NOTE: The anti-corrosive agents become less effective after a time, which means that the coolant must be replaced, see “Service schematic”. The cooling system should be flushed out at the same time as the coolant is replaced, see “Cooling system. Flushing”.

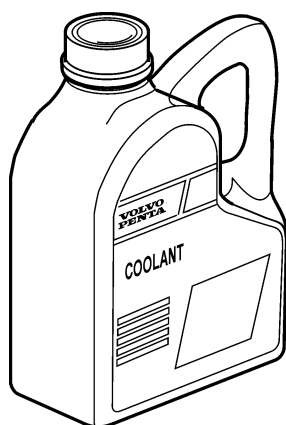

“**Volvo Penta Coolant**” is a concentrated coolant that is to be mixed with water. It has been developed to function optimally with Volvo Penta’s engines and provides excellent protection against corrosion, cavitation and frost damage.

“**Volvo Penta Coolant, Ready Mixed**” is a ready-mixed coolant, 40% “Volvo Penta Coolant” and 60% water. This concentration protects the engine against corrosion, cavitation damage and freezing conditions down to -28 °C (18°F).

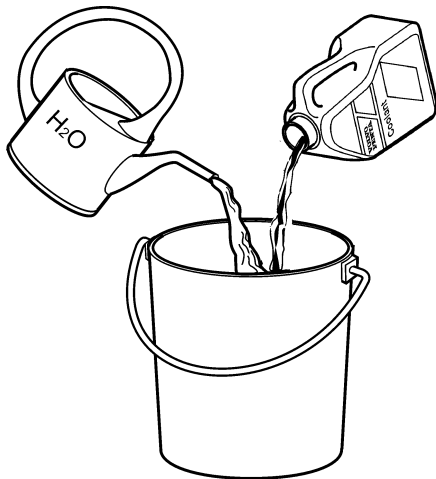

Coolant. Mixture

⚠ WARNING! All glycol is hazardous and harmful to the environment. Do not consume! Glycol is flammable.

⚠ IMPORTANT! Ethylene glycol must not be mixed with other types of glycol.

Mix:
40 % “Volvo Penta Coolant” (conc. coolant)
60 % water

This mixture protects the engine against internal corrosion, cavitation and frost damage down to -28 °C (18°F). (Using 60 % glycol lowers the freezing point to -54 °C (65°F)). Never mix more than 60 % concentrate (Volvo Penta Coolant) in the cooling liquid, this will give reduced cooling effect and increase the risk of overheating, and will give reduced freezing protection.

⚠ IMPORTANT! Coolant must be mixed with **pure** water, use **distilled - de-ionized water**. The water must fulfill the requirements specified by Volvo Penta, see “Water quality”.

⚠ IMPORTANT! It is extremely important that the correct concentration of coolant is added to the system. Mix in a separate, clean vessel before adding into the cooling system. Ensure that the liquids mix properly.

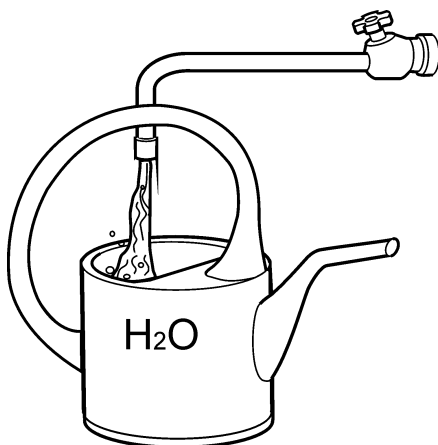

Water quality

ASTM D4985:

Total solid particles	< 340 ppm
Total hardness:	< 9.5° dH
Chloride	< 40 ppm
Sulfate	< 100 ppm
pH value	5,5–9
Silica (acc. ASTM D859)	< 20 mg SiO ₂ /l
Iron (acc. ASTM D1068)	< 0.10 ppm
Manganese (acc. ASTM D858)	< 0.05 ppm
Conductivity (acc. ASTM D1125)	< 500 µS/cm
Organic content, COD _{Mn} (acc. ISO8467)	< 15 mg KMnO ₄ /l

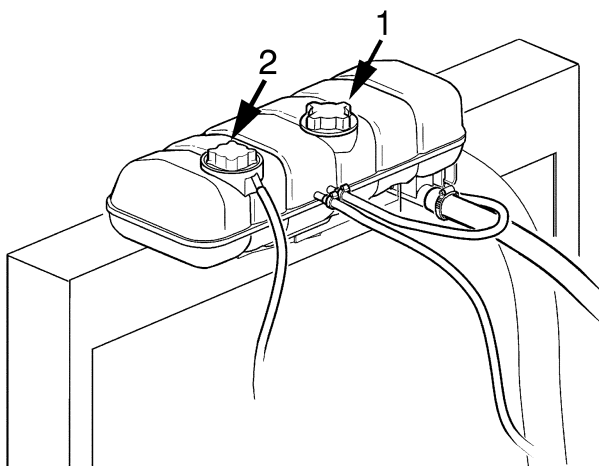

Coolant level, check

⚠ WARNING! Do not open the coolant filler cap (1) when the engine is warm. Steam or hot coolant can squirt out as pressure is released.

NOTE! Only open the filler cap (1). Do not open the pressure cap.

The coolant level should be above the MIN mark. Add coolant as needed according to the description in "Adding, cooling system".

Adding, cooling system

⚠ WARNING! Do not open the coolant filler cap (1) when the engine is warm. Steam or hot coolant can squirt out as pressure is released.

NOTE! Do not open the pressure cap.

1. Open the filler cap (1).

NOTE! Use only Volvo Penta recommended coolant and mixtures.

2. Mix the correct amount of coolant ahead of time (see the table below) so that it can be assured that the system has been filled. Filling must not be done so quickly that air pockets form in the system. Air must be given the chance to flow out through the filler opening and drain valves.

When adding coolant, the coolant level should be between the MIN and MAX markings.

3. Start the engine when the cooling system has been bled of air and filled completely. If there is a heater attached to the engine's cooling system the heater control valve should be opened and the unit should also be bled of air during filling.

4. Stop the engine after approximately 1 hour, check the coolant level and add coolant as needed.

Coolant volume	
Volume (engine)	20 liters (5.3 US gal)
Volume (engine, radiator + hoses)	44 liters (11.6 US gal)

Draining, cooling system

⚠ WARNING! Do not open the coolant filler cap (1) when the engine is warm. Steam or hot coolant can squirt out.

1. Remove the filler cap (1).
2. Open all of the drain valves. Drain the coolant from the radiator. Use drain hose that can be ordered from Volvo Penta, the drain cock (P) is located under the radiator.
3. Make sure that all coolant runs out. Deposits may exist just inside of the cocks/plugs that must be cleaned away. If this is not done there is a risk that coolant will be left in the engine where it can cause serious damage. Check to see if the installation has additional cocks or plugs at the lowest points of the coolant system.
4. Close the cocks and replace any plugs.

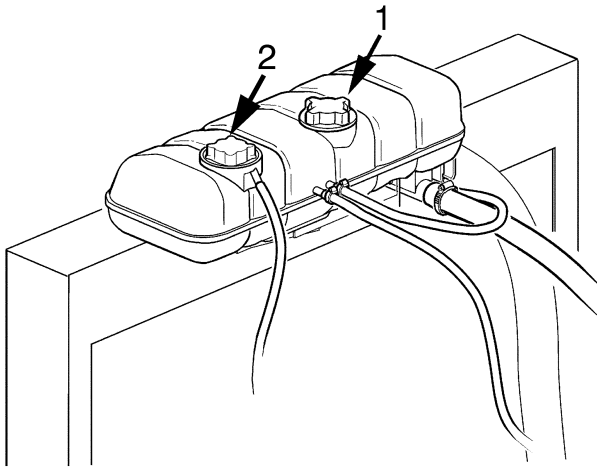

TAD

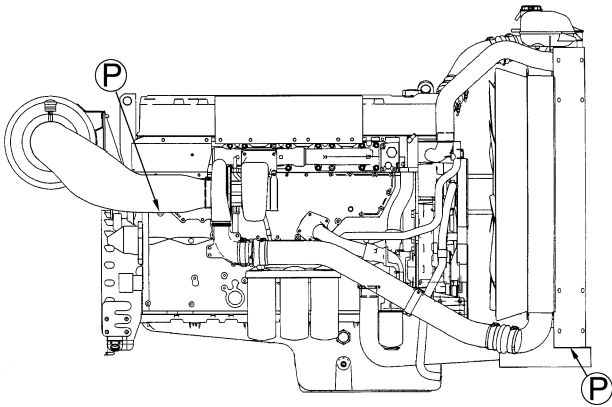

P = Coolant drain cock/plug

TWD

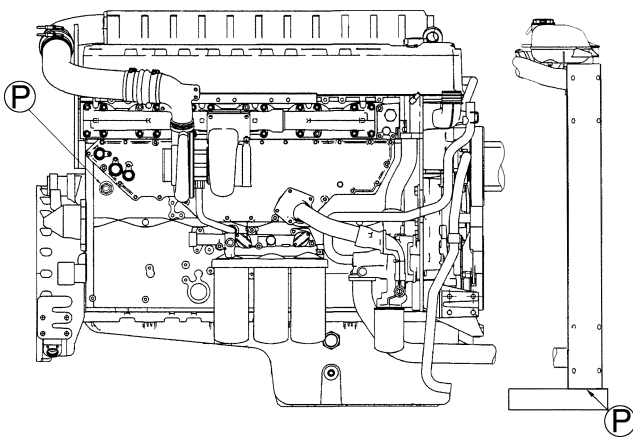

P = Coolant drain cock/plug

Cooling system, flushing

1. Drain the cooling system, see “Draining, cooling system”.

NOTE! If the cooling system is flushed regularly, for example by draining and refilling with rust-preventative fluid, a smaller amount of flushing additive or simple rinsing with clean water can be sufficient.

2. Rinse the cooling system clean with water.
3. Fill the cooling system with radiator flushing agent. Following this the engine should be operated for at least 2 hours after normal operating temperature has been reached.

NOTE! As an alternative the cooling system can be filled with 15–20% concentrated coolant which is drained after 1–2 days of operation.

4. Empty the cooling system and then rinse out the system with a neutralizing mixture.
5. If impurities still exist repeat the cleaning procedure until the system is free from impurities.
6. When the cooling system is completely clean, fill it with new coolant. In markets where Volvo Penta’s concentrated coolant is not available, use anti-corrosive additives and water.

NOTE! Mix the correct amount ahead of time so that it can be established that the system is full.

Coolant filter, change

1. Turn the valve (1) 90° to stop the flow through the coolant filter.
2. Remove the coolant filter using an appropriate filter wrench. Make sure that no residue from the old gasket remains on the housing.
3. Spread a thin layer of engine oil on the new coolant filter's gasket. Tighten the coolant filter by hand until the rubber seal contacts the sealing surface on the filter bracket. Tighten the coolant filter 1/2 turn.
4. Turn the valve (1) 90° to start the flow through the coolant filter again.
5. Start the engine and check for leaks.
6. Shut-off the engine and check the coolant level, see "Coolant level, check".

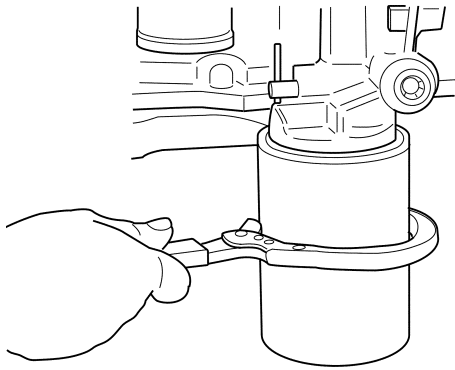
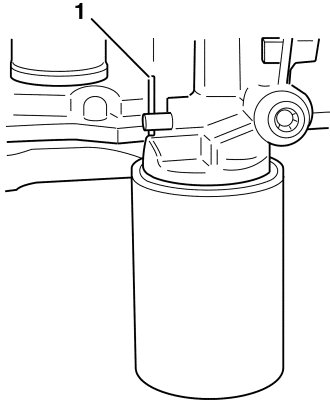

Fuel system

Only use fuel of the recommended grade according to the fuel specification below. Always make sure to maintain a high level of cleanliness when fueling and when working with the fuel system.

All work involving the engine's unit injectors must be performed by an authorized service location.

⚠ WARNING! Risk of fire. Work on the fuel system must be performed on a cold engine. Fuel leakage and spillage onto hot surfaces or electrical components can cause a fire. Store fuel-soaked rags in a fire-safe manner.

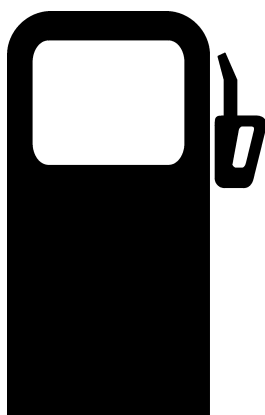

Fuel specification

The fuel must at least satisfy national and international standards for market fuel, for example:

EN 590 (with nationally adjusted environmental and temperature requirements)

ASTM-D975-No. 1-D, 2-D

JIS KK 2204

Sulfur content: According to legal requirements in each respective country. If the sulfur content exceeds 0.5 percent by weight **oil change intervals** must be changed, see "Lubrication system".

Note that low-density fuel (urban diesel in Sweden and citydiesel in Finland) can cause a power reduction of approximately 5% and a decrease in fuel economy of approximately 2–3%.

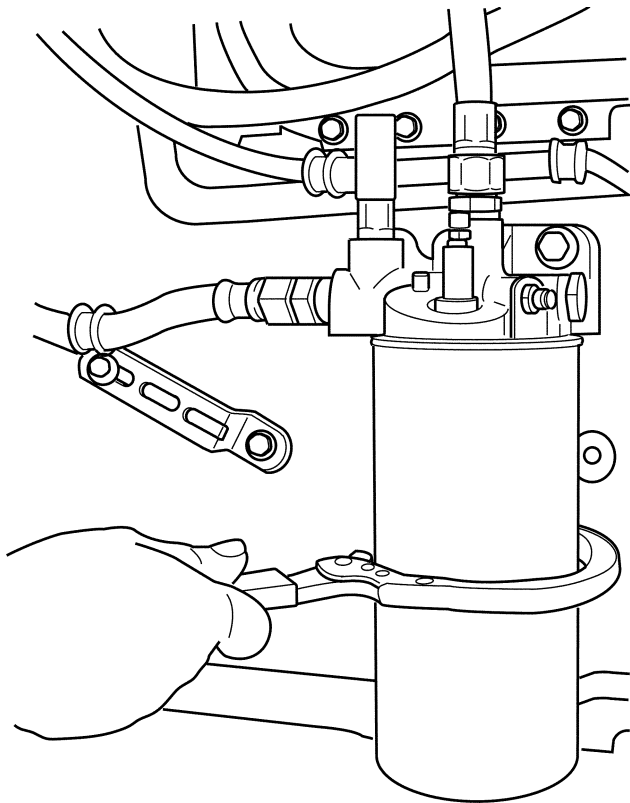

Fuel filter, change

NOTE! Do not fill the new fuel filter with fuel prior to mounting, there is a risk that impurities can be introduced into the system causing operational interruptions or damage.

⚠ WARNING! Fuel filter replacement should be carried out on a cold engine to avoid the risk of fire caused by fuel spilling onto hot surfaces.

1. Clean the area around the fuel filter.
2. Drain the fuel filter, see "Fuel system, draining, condensation water".
3. Remove the filter using an appropriate filter wrench.
4. Clean the filter's sealing surface on the filter housing.
5. Spread a thin layer of oil on the sealing ring and mount the new fuel filter. Tighten the fuel filter according to the instructions on the filter.
6. Purge the fuel system in proximity to the fuel filter, see "Fuel system, purging".
7. Operate the engine at a higher idle speed for approximately 10 minutes to remove any remaining air from the system. Conduct leakage and functional checks.

Fuel pre-filter with water monitor, change

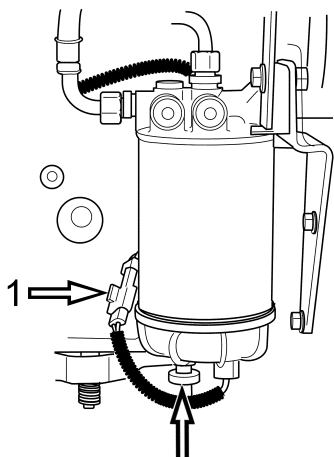

1. Clean the area around the fuel filter.
2. Disconnect the water monitor(1).
3. Drain the fuel filter, see "Fuel system, draining".
4. Remove the fuel filter using an appropriate filter wrench.

NOTE! If the entire filter unit with the water separator is not going to be changed the water monitor should be moved to the new fuel filter.

5. Clean the filter's sealing surface on the filter housing.
6. Spread a thin layer of oil on the sealing ring and mount the new fuel filter according to the instructions on the filter.
7. Connect the water monitor (1).
8. Start the engine and check for leaks.

Fuel pre-filter, draining of condensation water

⚠ IMPORTANT! Wait a few hours after the engine has been turned off before draining the filter.

1. Open the drain nipple (2) in the bottom of the fuel pre-filter and let the condensation water run out.

NOTE! Place a container under the fuel pre-filter to catch the condensation water and fuel.

2. Close the drain nipple (2) when water-free fuel comes out.
3. Start the engine and let the engine fill the water separator. Let the engine idle for 10 minutes to remove the air from the fuel system.
4. Shut off the engine and check for leaks.

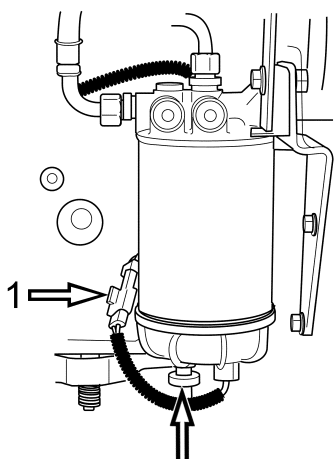

Fuel system, bleeding

1. Clean around the air bleeding nipples on the cylinder head and the fuel filter bracket.
2. Bleed the fuel system at the fuel filter. Connect a transparent plastic hose between the bleed nipple (1) and a collection vessel.
3. Open the bleed nipple on the fuel filter bracket.
4. Pump with the hand pump until air-free fuel flows out. Close the bleed nipple while the fuel is flowing out.
5. Remove the hose and replace the protective cap on the bleed nipples.

NOTE! When changing the fuel filter no additional bleeding is required.

6. Move the hose to the cylinder head's bleed nipple (2) and bleed in the same manner as with the fuel filter bracket.
7. Run the engine at a higher idle speed for approximately 10 minutes to remove any remaining air from the system.
8. Conduct leakage and functional checks.

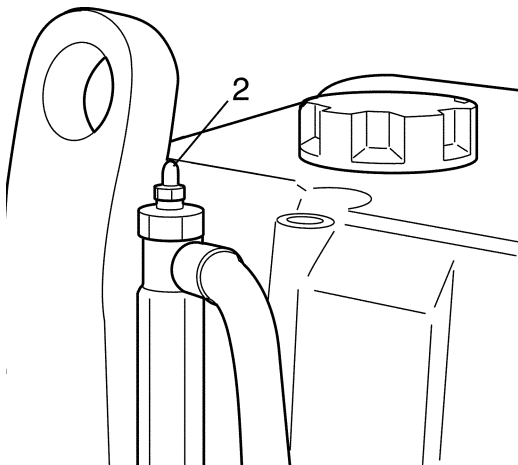
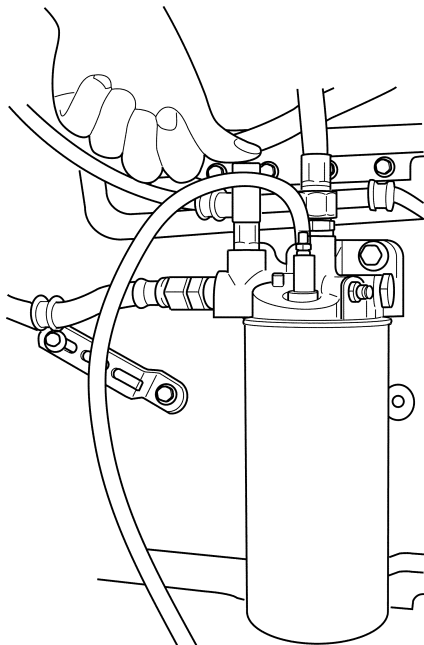
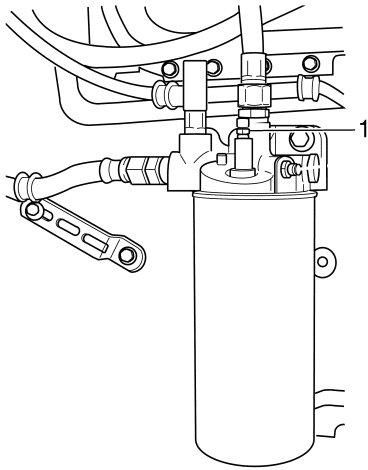

Electrical system

The engine is equipped with a 2-pole electric system and with an alternator. System voltage is 24V.

⚠ WARNING! Before performing service on the electric system the engine should be stopped and the power disconnected at the main switch. All connections to battery chargers or other equipment must be disconnected.

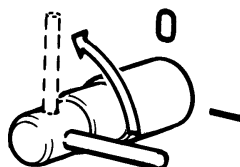

Main switch

The main switch must never be switched off before the engine has been stopped. If the circuit between the generator and the battery is broken while the engine is running the generator and the electronics can be damaged. For the same reason reconnection of the charging circuits must never be carried out while the engine is running.

⚠ IMPORTANT! Never switch off the power with the main switch while the engine is running.

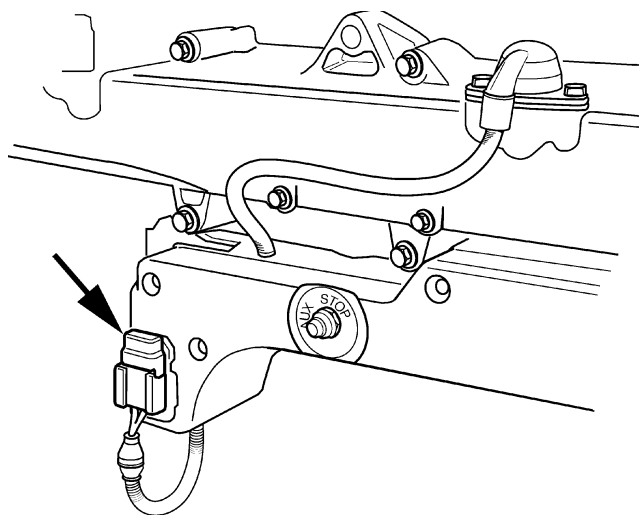

Fuses

The engine is equipped with a 10A fuse that shuts off the power in case of an overload in the electrical system.

The fuse is placed adjacent to the engine control unit on the engine's left side.

Note: The engine will stop if the **fuse (+)** blows out.

If the fuse blows out often an authorized Volvo Penta repair facility should be contacted to investigate the cause of the overload.



Batteries, maintenance

⚠ WARNING! Fire and explosion risk. Batteries may never be exposed to open flame or sparks.

⚠ WARNING! Never confuse the plus and minus poles of the batteries. Risk of causing sparks and explosion.

⚠ WARNING! Battery electrolytes is strongly corrosive. Protect eyes, skin and clothing during all handling of batteries.

⚠ WARNING! Always use safety glasses and gloves. In case of skin contact, wash with soap and large quantities of water.

⚠ WARNING! In case of eye contact rinse immediately with large quantities of water and contact a doctor as soon as possible.

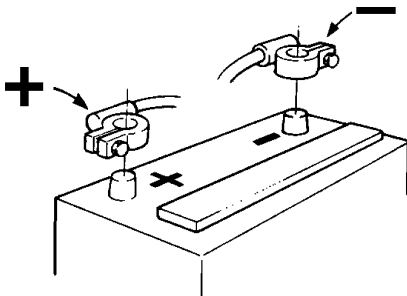

Connection and disconnection

When connecting batteries first connect the + cable (red) to the battery's + pole. Then connect the – cable (black) to the battery's – pole.

When disconnecting batteries disconnect the – cable (black) first, then the + cable (red).

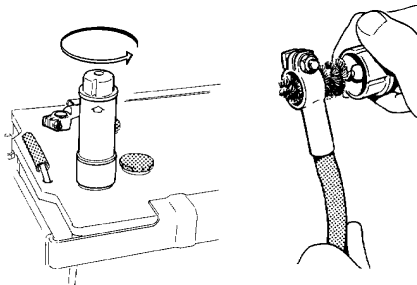

Cleaning

Keep the batteries dry and clean. Contamination and oxidation on the battery and the battery poles can cause current leaks, a reduction in voltage and discharge, especially during times of humid weather. Clean oxidation from the battery poles and cable ends using a brass brush. Tighten the cable ends and protect them using pole grease or Vaseline.

Electrolyte level

The Electrolyte level should be 5–10 mm over the cell plates in the battery. Add battery water as needed.

After filling the batteries should be charged by being connected to a battery charger, or by running the engine in normal operation for at least 30 minutes.

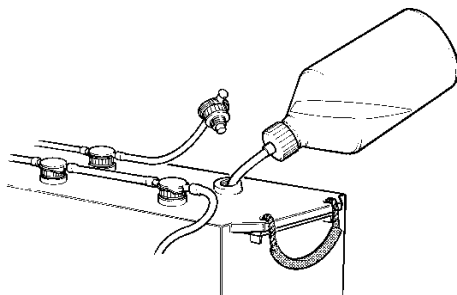

NOTE! Certain maintenance-free batteries have special instructions that must be followed.

⚠ IMPORTANT! Never switch the batteries + pole and - pole.

Batteries, charging

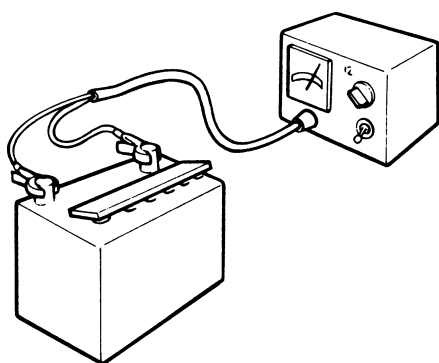

⚠ WARNING! Explosion risk. During charging oxyhydrogen gas is formed. Short-circuits, open flame or sparks can cause a powerful explosion. Ventilate well.

⚠ WARNING! Battery electrolyte is strongly corrosive. Protect eyes, skin and clothing. Always use safety glasses and gloves. In case of skin contact, wash with soap and large quantities of water. In case of eye contact rinse immediately with large quantities of water and contact a doctor as soon as possible.

Charge batteries if they have become discharged. If the engine is not used for an extended period the batteries should be fully charged initially and receive periodic maintenance charging (see the battery manufacturers recommendations). A discharged state damages batteries and they can also freeze and break during cold weather.

⚠ IMPORTANT! Carefully follow all instructions for the battery charger. To avoid risk for electrochemical corrosion when using an external charger when an external charger is used the battery cables should be removed from the battery before the charger is connected.

During charging the cell plugs should be unscrewed but remain in the plugholes. Ventilate well, especially if the battery is being charged in an enclosed space.

⚠ WARNING! Always turn off the charger before loosening the charging clamps. Never confuse the + and - poles of the batteries. Risk of causing sparks and explosion.

There are special instructions for so-called **quick-charging**. Quick-charging can shorten the useful life of the battery and should therefore be avoided.

Electric component schematic

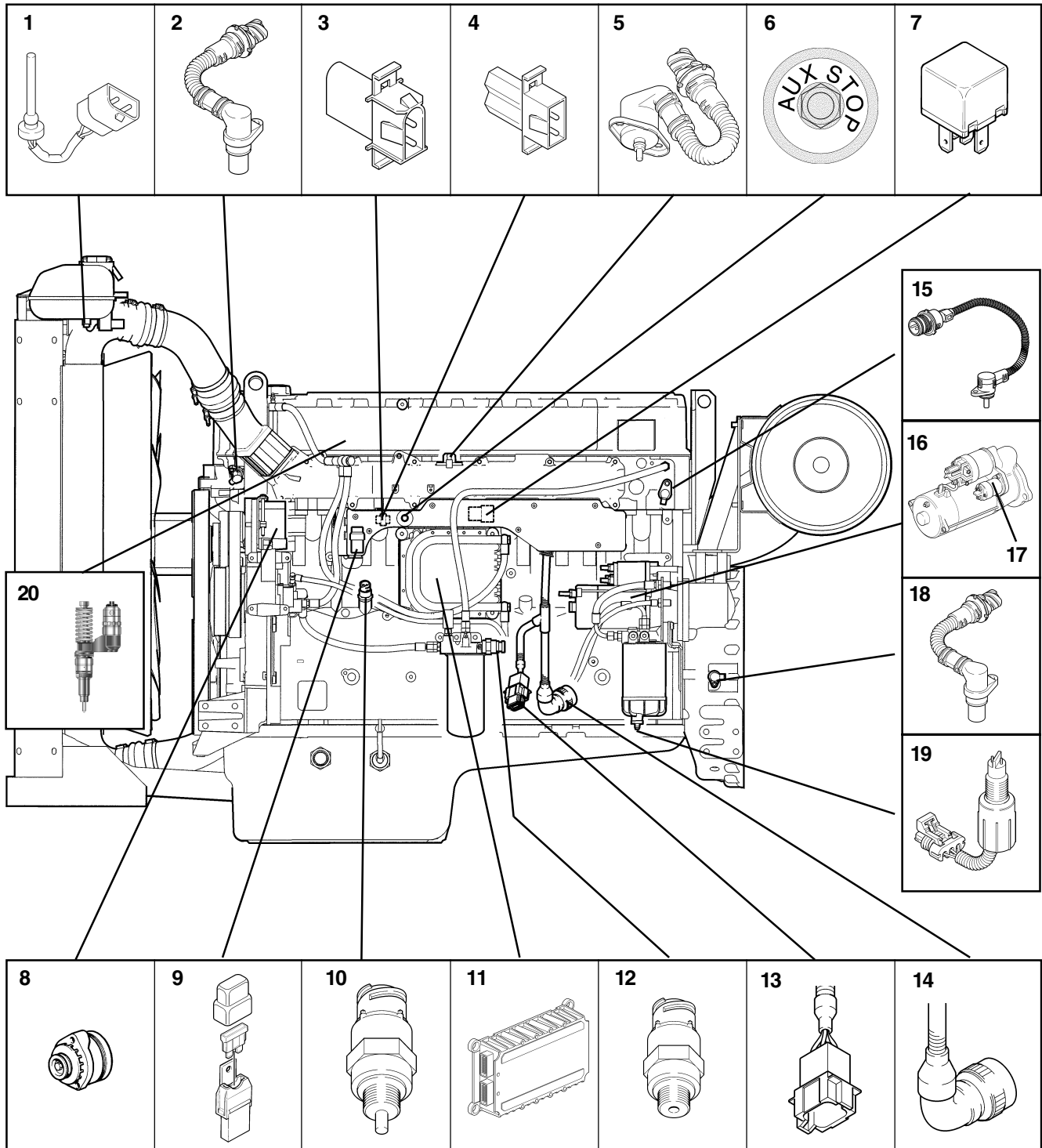

- | | |
|-----------------------------------------------------------------------------------------------------------------------------------------------------------------------------------------------------------------------------------------------------------------------------------------------------------------------------------------------------------------------------------|--------------------------------------------------------------------------------------------------------------------------------------------------------------------------------------------------------------------------------------------------------------------------------------------------------------------------------------------------------------------------------------------------|
| <ul style="list-style-type: none"> 1. Coolant level sensor 2. RPM sensor, camshaft 3. Diagnostic outlet 4. Programming connection 5. Boost pressure/intake temperature sensor 6. Extra stop 7. Main relay 8. Generator 9. Safety fuse 10A 10. Oil pressure/Oil temperature sensor | <ul style="list-style-type: none"> 11. Control unit 12. Fuel pressure alarm 13. 8-pin connector 14. 23-pin connector 15. Coolant temperature sensor 16. Starter motor 17. Starter motor, relay 18. RPM sensor, flywheel 19. Water monitor, fuel filter 20. Unit injector (one for each cylinder) |
|-----------------------------------------------------------------------------------------------------------------------------------------------------------------------------------------------------------------------------------------------------------------------------------------------------------------------------------------------------------------------------------|--------------------------------------------------------------------------------------------------------------------------------------------------------------------------------------------------------------------------------------------------------------------------------------------------------------------------------------------------------------------------------------------------|

7745138 - Downloaded from www.volvopecta.com 5/24/2007 11:04:40 PM

Preparation for storage

To prevent the engine and other equipment from suffering damage during periods of storage exceeding two months a preservation procedure should be performed. It is important that this be done correctly and that no part of it be forgotten. We have therefore created a checklist covering the most important points.

Before the engine is taken out of service for an extended period an authorized Volvo Penta service facility should perform a check.

Problems should be addressed at this point so that the equipment will be ready for use when needed next.

⚠ WARNING! Prior to starting maintenance work the chapter "Maintenance" should be read carefully. In it you will find instructions for how the work can be carried out in a safe and correct manner

⚠ WARNING! Certain preservation oils are flammable. Some even produce dangerous fumes. Make sure that there is good ventilation. Use a protective mask when spraying.

⚠ IMPORTANT! When cleaning with a high-pressure sprayer the following instructions must be kept in mind: Never point the spray at seals, rubber hoses or electric components. Never use the high-pressure function while cleaning the engine.

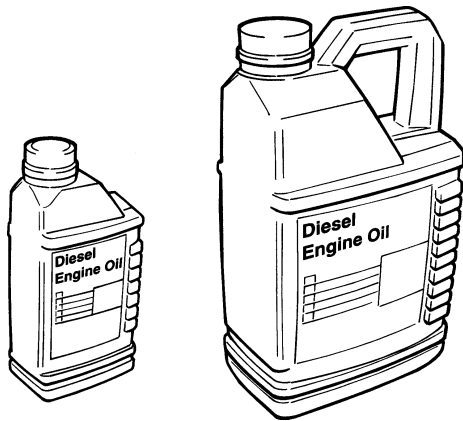

Preparation for storage

● For periods of storage up to 8 months:

Change the engine oil and oil filter and then run until warm.

For periods of storage longer than 8 months:

Preserve the lubrication and fuel systems with preservation oil. **See instructions on next page.**

- Make sure that the coolant's freeze protection is sufficient. Supplement as needed. As an alternative the coolant can be drained (drain also the coolant filter).
- Drain off any water and contamination from the fuel filter and the fuel tank. Fill the tank completely full with fuel to avoid building of condensation.
- Disconnect the battery cables and clean and charge the batteries. Maintenance charge the batteries periodically during the storage period. **A poorly charged battery can freeze and break.**
- Clean the engine externally. Do not use high-pressure spray when cleaning the engine. Touch-up paint damage using Volvo Penta original paint.
- Spray the electrical system's components with a water displacing spray.
- Check and treat control cables using rust-preventative.
- Affix a note on the engine showing the date, type of preservation and type of preservation oil is provided.
- Cover the air filter, exhaust pipe and the engine if called for.

Preparation for use after storage

- Remove any covers from the engine, air filter and exhaust pipe.
- Fill the engine with the proper grade of lubricating oil as needed. Mount a new oil filter if a filter change was not performed in conjunction with the preservation process.
- Mount a new fuel filter and purge the fuel system.
- Check the drive belt/s.
- Check the condition of the hoses and check-tighten the hose clamps.
- Close the drain valves and replace any drain plugs.
- Check the coolant levels. Add as needed.
- Connect the fully charged batteries.
- Start the engine and run until warm at a high idle speed prior to apply load to the engine.
- Check that no leakage of oil, fuel or coolant occurs.

Preservation of lubrication and fuel systems for storage exceeding 8 months:

- Drain the oil from the engine and fill it with **preserving oil*** to just over the MIN marking on the dipstick.
- Connect the suction and return fuel lines to a container filled with 1/3 **preservation oil*** and 2/3 diesel fuel.
- Bleed the fuel system.
- Start the engine and operate at a high idle speed until approximately two liters have been used. Shut off the engine and connect the normal fuel lines.
- Empty the preservation oil from the engine.
- Follow otherwise the instructions on the previous page.

*Preservation oil is distributed by oil manufacturers.

Troubleshooting

A number of symptoms and possible causes for engine problems are described in the table below. Always contact your Volvo Penta dealer if problems occur that you are not able to solve on your own.

⚠ WARNING! Read through the safety instructions for maintenance and service work in the chapter "Safety information" before starting to work.

Symptoms and possible causes

⚡Diagnostic button's indicator is blinking	See the chapter "Diagnostic function".
The engine can not be stopped	2, 5
The starter motor does not turn over	1, 2, 3, 4, 5, 6, 7, 8, 25
The starter motor turns slowly	1, 2
The starter motor turns normally but the engine does not start	9, 10, 11, 12, 13
The engine starts but stops again	9, 10, 11, 12, 14
The engine does not reach the correct operational RPM with full throttle	10, 11, 12, 13, 14, 15, 22, 26, 27, 28
The engine does not run smoothly	11, 12, 13
Poor fuel economy	13, 14, 16, 26
Black exhaust smoke	13, 14
Blue or white exhaust smoke	15, 16, 23
Insufficient lubricating oil pressure	17
Excessive coolant temperature	18, 19, 20, 21
Insufficient coolant temperature	21
Absent or poor charging	2, 24

- | | | |
|------------------------------------------------------------------------------------------------------------------------|----------------------------------------------------------------------------------------------------------------------------------------------------------------------------------------------------------------------------------------------------------------|---------------------------------------------|
| 1. Discharged batteries | 11. Air in the fuel system | 17. Insufficient lubrication oil level |
| 2. Poor connection/broken wires | 12. Water/contamination in the fuel | 18. Low coolant level |
| 3. Main switch turned off | 13. Malfunctioning injector (injectors) | 19. Air in the fresh water coolant system |
| 4. Fuse on the wiring box blown | 14. Insufficient air to the engine:
- blocked air filter
- air leakage between the turbo and the engine intake plenum
- contaminated compressor section in the turbocharger
- malfunctioning turbocharger
- poor engine compartment ventilation | 20. Malfunctioning circulation pump |
| 5. Malfunctioning start lock | 15. Excessive coolant temperature | 21. Defective thermostat |
| 6. Malfunctioning main relay | 16. Insufficient coolant temperature | 22. Blocked intercooler |
| 7. Malfunctioning starter motor relay | | 23. Excessive lubricating oil level |
| 8. Malfunctioning starter motor/solenoid | | 24. Generator drive belt slippage |
| 9. Out of fuel:
- fuel valves closed
- fuel tank empty/wrong tank connected | | 25. Water inside the engine |
| 10. Blocked fuel filter/pre-filter (because of contamination or paraffin condensation in the fuel at low temperatures) | | 26. High backpressure in the exhaust system |
| | | 27. High oil temperature |
| | | 28. High charge-air temperature |

Diagnostic function

The diagnostic function monitors and checks that the EMS 2 system functions normally.

The diagnostic function has the following tasks:

- Discover and localize malfunctions
- Notify that malfunctions have been discovered
- Give advice in fault finding

Fault code

If the diagnostic function discovers a malfunction in the EMS 2 system, this is reported by means of fault codes/fault cause on the instruments.

Both inactive (rectified) and active (un-mended) faults are stored in the control unit.

Please refer to the "Operation" heading for reading fault codes.

All fault codes are found in the fault code list, with information about the reason, reaction and measures to be taken. Please refer to the "Fault codes" chapter.

NOTE! All instruments are optional

Active faults

DCU (Display Control Unit) / DU (Display Unit)

- "text" !! ENGINE WARNING !! is shown on the display.

NOTE! It's possible to choose which language the information will be presented in.

CIU (Control Interface Unit)

- the diagnostic lamp starts to flash.
- **"Easy-link" instrument** (requires a CIU)
 - warning lamp on the alarm panel lights up
 - after the diagnostic button has been pressed, the fault code is shown as text on the tachometer display.

DU (Display Unit)

- Either "WARNING!" or "ALARM STOP" (a buzzer sounds) will be shown on the display, depending on the severity of the fault.

NOTE! You can choose the language used for the information presented on the.

- Fault codes can also be read by means of the **VODIA** tool. Please refer to the "VODIA User's Guide" for advice on use.

At the same time, the fault is stored in the control unit memory. When the fault has been attended to and the ignition is switched off and on again, the fault disappears as active.

Inactive faults

- DCU - the fault is indicated as passive
- CIU - the diagnostic lamp goes out
- DU - the fault message disappears (inactive faults can not be read)
- "Easy Link" - the warning lamp on the alarm panel turns off

Effect on engine

Engines are affected differently, depending on the severity of the fault discovered by the diagnostic function.

A fault message in the form of a fault code is always generated when a malfunction is discovered by the diagnostic function.

Engines are affected differently, depending on the severity of the fault.

- The engine is not affected
- Engine idles
- Engine torque is restricted to a certain amount
- Engine is stopped

Operation

When a malfunction has occurred and the diagnostic system has generated one or more fault codes, these are read out differently, depending on the equipment used. Please refer to "Fault codes".

If the system indicates that a fault code has been set:

1. Cut engine speed to idle, or shut the engine off.
2. **For DCU/DU**
Read the fault code set from the display, please refer to "Reading fault cause via the DCU" or "Reading fault cause via DU".

For CIU

Press the diagnostic button and read the fault code that has been set, by observing the flashing of the diagnostic lamp. Please refer to "Reading fault codes via the diagnostic lamp, CIU"

3. Look up the fault code/cause in the "Fault Code" chapter and take the recommended measures.

Reading fault cause via the DCU (Display Control Unit)

When a fault code is set, the following text is shown on the display:

"!! ENGINE WARNING !!"

alternated with

"Press SEL for information".

NOTE! You can choose the language used for the information presented on the.

Read the fault code as follows:

1. Press the SEL button (to come to the error list.
The fault list shows:
 - Operation hours
 - Fault cause
 - Active/inactive
2. Look up the fault code in the "Fault Code" chapter and take the recommended measures.
3. Press the ESC button to leave the fault list.

NOTE! To enter the fault list when no fault code has been set, press the SEL button and select "Diagnostics" from the menu.

Reading fault cause via the DU (Display Unit)

Depending on the severity of the faults, one of the following messages will appear on the display: "**WARNING!**" or "**ALARM STOP**" (a buzzer sounds).

1. Press any button to come to the fault list.
The fault list shows:
 - Operation hours
 - Fault cause
2. Look up the fault code in the "Fault Code" chapter and take the recommended measures.
3. Press **ACK** to confirm the fault code. The display background will change color (the buzzer stops sounding).
4. Press **EXIT** to leave the fault list.

Reading fault codes via the diagnostic lamp on the instrument panel, CIU

When the system has discovered a malfunction, the diagnostic lamp starts to flash. If the diagnostic button is depressed and then released, a fault code is flashed out.

The fault code consists of two groups of flashes, separated by a pause of two seconds. A fault code is obtained by counting the number of flashes in each group.

Example: ✨ ✨ pause ✨ ✨ ✨ ✨ = Fault code 2.4

The fault code is stored and can be read as long as the malfunction remains. You can find information about cause, reaction and actions in the "Fault Code" chapter.

Read the fault code as follows:

1. Press the diagnostic button.
2. Release the diagnostic button and make a note of the fault that is flashed out.
3. Repeat items 1-2. A new fault code is flashed out if more are stored. Repeat until the first fault code is repeated.
4. Look up the fault code in the "Fault Code" chapter and take the recommended measures.

NOTE! When the first fault code is repeated, all fault codes have been read out.

If the diagnostic button is pressed after the fault has been mended and the fault codes have been erased, code 1.1 "No fault" will be displayed.

Reading fault codes via "Easy Link" instrument (only with CIU)

When the system has discovered a malfunction, the diagnostic lamp starts to flash and the fault code will show in the display of the tachometer.

1. Press the diagnostic button, the fault code will show in the display of the tachometer.
2. Look up the fault code in the "Fault Code" chapter and take the recommended measures.
3. When the fault has been attended to, the fault code disappears from the display and the diagnostic lamp goes out.

Erasing fault codes

Fault codes must be erased by means of the VODIA tool.

Fault codes

⚠ WARNING! Read through the safety advice for care and maintenance work in the "Safety information" chapter before you start work.

NOTE! Reading the fault codes below, such as **Code 2.1, PID 97** means that **2.1** is the flashing code indicated by the diagnostic lamp. **PID 97** is read with the VODIA diagnostic tool. With the use of DCU or DU the fault message will be shown as text in the display.

NOTE! Please refer to "Wiring schedule CIU and DCU" for references to the sleeves in the electrical connectors on the engine control unit.

Code 1.1 No faults

There are no active faults.

Code 2.1, PID / SPN 97. Water in fuel

Cause:

- Water in fuel.

Reaction:

- None.

Remedy:

- Empty the primary fuel filter.

Code 2.2, PID / SPN 111. Coolant level

Cause:

- Low coolant level.

Reaction:

- Warning indication.
- Engine control module reduces engine power (unless the protection has been shut off with the VODIA diagnostic tool).

Remedy:

- Check the coolant level.
- Check coolant level monitor function.

Code 2.3, PID / SPN 111. Coolant level sensor

Cause:

- Short circuit to positive (+).
- Fault in sensor.

Reaction:

- None.

Remedy:

- Check that the coolant level sensor cable is not damaged.
- Check coolant level sensor function.

Code 2.4. SID21 / SPN 637 Flywheel speed sensor

Cause:

- No signal.
- Abnormal frequency.
- "Intermittent" signal from the sensor.
- Fault in sensor.

Reaction:

- Engine is very difficult to start and runs roughly when it starts.

Remedy:

- Check that the sensor connector is correctly installed.
- Check that the engine speed sensor cable is not damaged.
- Check that the engine speed sensor is correctly installed in the flywheelhousing.
- Check engine speed sensor function.

Code 2.5, SID22 / SPN 636 Camshaft drive speed sensor

Cause:

- No signal.
- Abnormal frequency.
- Fault in sensor.

Reaction:

- Engine takes longer to start than normal. Engine runs normally when running.

Remedy:

- Check that the engine speed sensor connector is correctly installed.
- Check that the engine speed sensor cable is not damaged.
- Check that the engine speed sensor is correctly installed in the upper timing gear cover.
- Check engine speed sensor function.

Code 2.6, PID / SPN 190. Engine speed

Cause:

- Engine speed too high.

Reaction:

- None.

Remedy:

- After the engine has stopped, look for the reason for the high speed.

**Code 2.8, PPID 132 / SPN 608
Speed potentiometer connected to CIU**

Cause:

- Shorted to plus (+) or minus (-).
- Fault in sensor.

Reaction:

- Engine goes to idle.

If you release the accelerator first, and then press it down again, the engine can be forced to run using the idle contact.

Remedy:

- Check that the potentiometer has been connected correctly.
- Check that the cable harness to the potentiometer has not been damaged.
- Check the potentiometer function.

**Code 2.9, PID / SPN 97
Indicator for water in fuel**

Cause:

- Short circuit
- Open circuit.
- Fault in indicator.

Reaction:

- None.

Remedy:

- Check the indicator cables for breaks and short circuits.
- Check indicator function. Change indicator as necessary

Code 3.1, PID / SPN 100. Oil pressure sensor

Cause:

- Short circuit to positive (+) or earth (ground) (-).
- Open circuit.

Reaction:

- None.

Remedy:

- Check that the oil pressure sensor cable is not damaged.
- Check that the oil pressure sensor is correctly connected.

**Code 3.2, PID / SPN 105
Charge air temperature sensor**

Cause:

- Short circuit to positive (+) or earth (ground) (-).
- Open circuit.

Reaction:

- None.

Remedy:

- Check that the charge air temperature sensor connector is correctly installed.
- Check that the charge air temperature sensor cable is not damaged.
- Check that the charge air temperature sensor is correctly installed.
- Check charge air temperature sensor function.

**Code 3.3, PID / SPN 110
Coolant temperature sensor**

Cause:

- Short circuit to positive (+) or earth (ground) (-).
- Open circuit.

Reaction:

- Preheating is also activated when the engine is hot.

Remedy:

- Check that the coolant temperature sensor connector is correctly installed.
- Check that the coolant temperature sensor cable is not damaged.
- Check that the coolant temperature sensor is correctly installed.
- Check coolant temperature sensor function.

Code 3.4, PID / SPN 106/102, Charge pressure sensor**Cause:**

- Short circuit to positive (+) or earth (ground) (-).
- Open circuit.

Reaction:

- Engine smokes more than normally during acceleration/load increase.

Remedy:

- Check that the charge pressure sensor connector is correctly installed.
- Check that the charge pressure sensor cable is not damaged.
- Check that the charge pressure sensor is correctly installed.
- Check charge pressure sensor function.

Code 3.5, PID / SPN 106/102. Charge pressure**Cause:**

- Charge pressure too high

Reaction:

- Engine control module reduces engine power (unless the protection has been shut off with the VODIA diagnostic tool).

Remedy:

- Check turbocharger compressor function.
- Check charge pressure sensor function.
- Check fuel volume/injector.

Code 3.6, PID / SPN 94. Fuel pressure sensor**Cause:**

- Short circuit to positive (+) or earth (ground) (-).
- Open circuit.

Reaction:

- None.

Remedy:

- Check that the fuel pressure sensor connector is correctly installed.
- Check that the fuel pressure sensor cable is not damaged.
- Check that the fuel pressure sensor is correctly installed.
- Check fuel pressure sensor function.

Code 3.7, PID / SPN 175. Oil temperature sensor**Cause:**

- Shorted to plus (+) or minus (-).
- Break.

Reaction:

- None.

Remedy:

- Check that the cable harness to the oil temperature sensor has not been damaged.
- Check that the oil temperature sensor has been connected correctly.

Code 3.8, PID / SPN 94. Fuel pressure**Cause:**

- Low supply pressure.

Reaction:

- None.

Remedy:

- Check if it is possible to build up pressure with the hand pump.
- Check the fuel filter.
- Check the fuel pre-filter.

Code 3.9, PID / SPN 158. Battery voltage, EDC**Cause:**

- Faulty alternator.
- Faulty battery, battery cables.

Reaction:

- None.

Remedy:

- Check the supply voltage from the control unit.

Code 4.1 PPID 260. Oil pressure alarm lamp, Connected to Stand-Alone Interface

Reason:

- Short circuit to negative (-).
- Short circuit to positive (+).
- Open circuit.

Reaction:

- Alarm lamp gives constant light.
- Alarm lamp does not work. If there is an open circuit on start-up, the diagnosis is de-activated.

Action:

- Check that the alarm lamp cable is not damaged.
- Check that the alarm lamp is intact and correctly installed.

Code 4.2 PPID 7. Coolant temperature alarm lamp, Connected to Stand-Alone Interface

Reason:

- Short circuit to negative (-).
- Short circuit to positive (+).
- Open circuit.

Reaction:

- Alarm lamp gives constant light.
- Alarm lamp does not work. If there is an open circuit on start-up, the diagnosis is de-activated.

Action:

- Check that the alarm lamp cable is not damaged.
- Check that the alarm lamp is intact and correctly installed.

Code 4.3 PPID 263 Operation indication lamp

Reason:

- Short circuit to negative (-).
- Short circuit to positive (+).
- Open circuit.

Reaction:

- Alarm lamp gives constant light.
- Alarm lamp does not work. If there is an open circuit on start-up, the diagnosis is de-activated.

Action:

- Check that the alarm lamp cable is not damaged.
- Check that the alarm lamp is intact and correctly installed.

Code 4.4 PPID 264. Overspeed alarm lamp, Connected to Stand-Alone Interface

Reason:

- Short circuit to negative (-).
- Short circuit to positive (+).
- Open circuit.

Reaction:

- Alarm lamp gives constant light.
- Alarm lamp does not work. If there is an open circuit on start-up, the diagnosis is de-activated.

Action:

- Check that the alarm lamp cable is not damaged.
- Check that the alarm lamp is intact and correctly installed.

Code 4.5 PPID 261. Electrical fault, Coolant temperature alarm lamp, Connected to Stand-Alone Interface

Reason:

- Short circuit to negative (-).
- Short circuit to positive (+).
- Open circuit.

Reaction:

- Alarm lamp gives constant light.
- Alarm lamp does not work. If there is an open circuit on start-up, the diagnosis is de-activated.

Action:

- Check that the alarm lamp cable is not damaged.
- Check that the alarm lamp is intact and correctly installed.

Code 4.6, PPID 3 / SID 39 / SPN 677 Start output / Start motor relay

Cause:

- Shorted to plus (+) or minus (-).
- Activated for too long.

Reaction:

- The engine cannot be started.
- The engine starts immediately when ignition is turned on.

Remedy:

- Check that connections to the ignition key have not been damaged.
- Check that the cable harness to the ignition key has not been damaged.

Code 4.8, PPID 6/ SPN 520195. Stop input EDC**Cause:**

- Short circuit to negative (-).
- Open circuit.

Reaction:

- Engine can only be stopped with the auxiliary stop.

Remedy:

- Check that the starter switch connections are not damaged.

Code 5.2, PPID 4 / SPN 520194. Starter input CIU**Cause:**

- Shorted to minus (-).
- Activated for too long.

Reaction:

- The engine cannot be started.
- The engine starts immediately when ignition is turned on.

Remedy:

- Check that connections to the ignition key have not been damaged.
- Check that the cable harness to the ignition key has not been damaged.

Code 5.3, PPID 6/ SPN 970. Stop input CIU**Cause:**

- Short circuit to negative (-).
- Open circuit.
- Activated for too long time.

Reaction:

- Engine can only be stopped with the auxiliary stop (AUX STOP) on engine.
- Engine stops. A fault code is displayed for 40 seconds and the engine can not be started during this time. When a fault code is active, the engine can be started but not stopped.

Remedy:

- Check that the starter switch connections are not damaged.
- Check that the ignition switch cable is not damaged.

Code 5.4, PID 45/ SPN 626. Preheating relay**Cause:**

- Short circuit to positive (+) or earth (ground) (-).
- Open circuit.

Reaction:

- Preheating can not be activated.
- Preheating is constantly connected.

Remedy:

- Check that the relay input cable is not damaged.
- Check relay function.

Code 5.6, PID/SPN 107. Air filter sensor**Cause:**

- Shorted to plus (+) or minus (-).
- Break.

Reaction:

- None

Remedy:

- Check that the air filter sensor contact is correctly installed.
- Check that the cable harness to air filter sensor has not been damaged.
- Check the air filter sensor functionality.

Code 5.7. PID / SPN 98, Oil level**Cause:**

- Oil level is too low.

Reaction:

- Warning indication.

Remedy:

- Check the oil level.

Code 5.8, PID / SPN 175. Oil temperature**Cause:**

- Oil temperature is too high

Reaction:

- Warning indication.
- The engine control module limits engine output (unless protection has been turned off with the diagnosis tool VODIA).

Remedy:

- Check the oil level.
- Check the oil temperature.
- Check the oil temperature sensor function.

Code 5.9, PID / SPN 98. Oil level sensor

Cause:

- Shorted to plus (+) or minus (-).
- Break.

Reaction:

- None.

Remedy:

- Check that the cable harness to the oil level sensor has not been damaged.
- Check the oil level sensor function.

Code 6.1, PID / SPN 110. Coolant temperature

Cause:

- Coolant temperature is too high.

Reaction:

- Engine control module reduces engine power (unless the protection has been shut off with the VODIA diagnostic tool).

Remedy:

- Check the coolant level.
- Check the intercooler (cleanliness).
- Check if there is air in the cooling system.
- Check the pressure cap on the expansion tank.
- Check coolant temperature sensor function.
- Check thermostat function.

Code 6.2, PID / SPN 105. Charge air temperature

Cause:

- Charge air temperature is too high.

Reaction:

- Engine control module reduces engine power (unless the protection has been shut off with the VODIA diagnostic tool).

Remedy:

- Check the coolant level.
- Check the intercooler (cleanliness).
- Check charge air temperature sensor function.
- Check the function of the thermostat.

Code 6.4, PPID 231 / SPN 639, Data link (CAN), CIU

Cause:

- Faulty data link (CAN), CIU.

Reaction:

- Instruments and warning lamps stop working.

Remedy:

- Check that the 8-pin connector is not damaged.
- Check that the cables between the CIU and the engine management unit are not damaged.

Code 6.5, PPID 231 / SPN 639, Data link (CAN), EDC

Cause:

- Internal fault in control module.

Reaction:

- Engine not operating: engine can not be started.
Engine operating: engine idles and can only be stopped with the auxiliary stop (AUX-stop).

Remedy:

- Check that the 8-pin connector is not damaged.
- Check that the cables between the CIU and the engine management unit are not damaged.
- Check that sleeves 11 and 12 in the connector on the CIU are not damaged.

Code 6.6, PID / SPN 100, Oil pressure

Cause:

- Oil pressure is too low.

Reaction:

- Engine control module reduces engine power (unless the protection has been shut off with the VODIA diagnostic tool).

Remedy:

- Check oil level.
- Check that the air filters are not blocked.
- Check system pressure valves and safety valves in the oil system.
- Check oil pressure sensor function.

Code 6.9, PID / SPN 158, Battery voltage, CIU**Cause:**

- Short circuit to negative (-).
- Faulty alternator.
- Faulty battery, battery cables.

Reaction:

- Problems in engine starting.

Remedy:

- Check the supply voltage from the control unit.
- Check the battery.
- Check the alternator.
- Check the 8-pin contact.

**Code 7.1, SID 1 / SPN 651
Injector, cylinder #1****Cause:**

- Electrical fault.
- Faulty compression or injector.

Reaction:

- Engine runs on 5 cylinders.
- Abnormal sound.
- Reduced performance.

Remedy:

- Check that the injector cables are not damaged.
- Check that the injector connections are not damaged.
- Check fuel supply pressure.
- Check the valve clearance.
- Do a compression test and check cylinder #1.

**Code 7.2, SID 2 / SPN 652
Injector, cylinder #2****Cause:**

- Electrical fault.
- Faulty compression or injector.

Reaction:

- Engine runs on 5 cylinders.
- Abnormal sound.
- Reduced performance.

Remedy:

- Check that the injector cables are not damaged.
- Check that the injector connections are not damaged.
- Check fuel supply pressure.
- Check the valve clearance.
- Do a compression test and check cylinder #2.

**Code 7.3, SID 3 / SPN 653
Injector, cylinder #3****Cause:**

- Electrical fault.
- Faulty compression or injector.

Reaction:

- Engine runs on 5 cylinders.
- Abnormal sound.
- Reduced performance.

Remedy:

- Check that the injector cables are not damaged.
- Check that the injector connections are not damaged.
- Check fuel supply pressure.
- Check the valve clearance.
- Do a compression test and check cylinder #3.

**Code 7.4, SID 4 / SPN 654
Injector, cylinder #4**

Cause:

- Electrical fault.
- Faulty compression or injector.

Reaction:

- Engine runs on 5 cylinders.
- Abnormal sound.
- Reduced performance.

Remedy:

- Check that the injector cables are not damaged.
- Check that the injector connections are not damaged.
- Check fuel supply pressure.
- Check the valve clearance.
- Do a compression test and check cylinder #4.

**Code 7.5, SID 5 / SPN 655
Injector, cylinder #5**

Cause:

- Electrical fault.
- Faulty compression or injector.

Reaction:

- Engine runs on 5 cylinders.
- Abnormal sound.
- Reduced performance.

Remedy:

- Check that the injector cables are not damaged.
- Check that the injector connections are not damaged.
- Check fuel supply pressure.
- Check the valve clearance.
- Do a compression test and check cylinder #5.

**Code 7.6, SID 6 / SPN 656
Injector, cylinder #6**

Cause:

- Electrical fault.
- Faulty compression or injector.

Reaction:

- Engine runs on 5 cylinders.
- Abnormal sound.
- Reduced performance.

Remedy:

- Check that the injector cables are not damaged.
- Check that the injector connections are not damaged.
- Check fuel supply pressure.
- Check the valve clearance.
- Do a compression test and check cylinder #6.

**Code 9.2, SID250 / SPN 608
Faulty data link (J1587)**

Cause:

- Faulty data link.

Reaction:

- None.

Remedy:

- Check that the 8-pin connector is not damaged.
- Check that the cables between the CIU/DCU and the engine management unit are not damaged.

Code 9.3. SID 232 / SPN 620
Power supply to sensor
Cause:

- Shortcut.
- Fault in sensor.

Reaction:

- Faulty values in oil pressure and charge air pressure sensors.
- Fault code for oil pressure- and charge air pressure sensor.
- Low engine output.
- The instrument shows zero oil pressure and boost pressure.

Remedy:

- Check that the cable harness to oil pressure and charge air pressure sensor has not been damaged.
- Check oil pressure and charge air pressure sensors.

Code 9.8, SID 253 / SPN 630
Data set memory EEPROM, CIU
Cause:

- Internal fault in control module
- Programming faulty.

Reaction:

- Engine does not start.

Remedy:

- Re-program the control module. If the fault remains, change the control module.

Code 9.8, PPID 254 / SPN 629
Fault in control unit, CIU
Cause:

- Faulty EEPROM, CIU.
- Faulty flash memory, CIU.
- Fault in control module, CIU

Reaction:

- CIU returns to factory setting.
- Engine goes to idle.
- Engine can not be started.

Remedy:

- Re- program the unit
- Change CIU unit.

Code 9.9, SID 240 / SPN 639. Memory fault
Cause:

- Memory fault in engine management system.

Reaction:

- Engine might not start.

Remedy:

- Re-program the unit.

Code 9.9, SID 253 / SPN 630
Data set memory EEPROM, EDC
Cause:

- Internal fault in control module
- Programming faulty.

Reaction:

- Engine does not start.

Remedy:

- Re-program the control module. If the fault remains, change the control module.

Code 9.9. SID 254 / SPN 629
Control module EDC
Cause:

- Internal fault in control module.

Reaction:

- Engine misfires.
- Engine does not start.

Remedy:

- Change engine control unit.

Technical Data

General

	TAD1240GE	TAD1241-42GE	TAD1241-42VE	TWD1240VE
Type designation	TAD1240GE	TAD1241-42GE	TAD1241-42VE	TWD1240VE
Number of cylinders	6	6	6	6
Cylinder diameter	131 mm (5.16")	131 mm (5.16")	131 mm (5.16")	131 mm (5.16")
Stroke	150 mm (5.91")	150 mm (5.91")	150 mm (5.91")	150 mm (5.91")
Displacement	12.13 liters (740.20 inch ³)	12.13 liters (740.20 inch ³)	12.13 liters (740.20 inch ³)	12.13 liters (740.20 inch ³)
Number of valves	24	24	24	24
Rotational direction (seen from the front) ..	Clockwise	Clockwise	Clockwise	Clockwise
Compression ratio	18.5:1	17.5:1	17.5:1	18.5:1
Firing order	1-5-3-6-2-4	1-5-3-6-2-4	1-5-3-6-2-4	1-5-3-6-2-4
Low idle, adjustable (rpm)	600-1200	600-1200	600-900	600-900
High idle, adjustable (rpm)	1500-1620 ¹⁾ /1800-1920	1500-1620 ¹⁾ /1800-1920	1800	2100 ¹⁾
Highest full load RPM	1500/1800	1500/1800	1800	2100
Dry weight (kg)	1230 ²⁾ (2706 lbs)	1230 ²⁾ (2706 lbs)	1230 ²⁾ (2706 lbs)	1270 (2794 lbs)

¹⁾ Not adjustable

²⁾ Weight of TAD engines without cooling package and air filter

Lubrication system

Oil Change volume including change of three filters:

With horizontal installation 35 liters (9.2 US gal)

Oil pressure

at Operational speed 1100 rpm or higher 400–550 kPa (58–80 psi)

Idle, min 175 kPa (25 psi)

Oil grade See chapter "Lubrication system".

Viscosity See chapter "Lubrication system".

Oil filter

Number 3

Full-flow filter

(tightened 1/2–3/4 turn after sealing surface contact) . 2

Bypass filter

(tightened 3/4–1 turn after sealing surface contact) 1

Oil pump

Type Gear driven

Fuel system

Injection order

Injection order 1-5-3-6-2-4

Feed pump

Feed pressure after fuel filter at
1000 RPM, min. 350 kPa (51 psi)

Feed pressure after fuel filter at
full load, min. 350 kPa (51 psi)

Overflow valve

Opening pressure 400–450 kPa (58–65 psi)

Fuel specification

The fuel must at least satisfy national and international standards for market fuel, for example:

EN 590 (with nationally adjusted environmental and temperature requirements)

ASTM-D975 No. 1-D and 2-D

JIS KK 2204

Sulfur content: According to legal requirements in each respective country.

Low-density fuel (urban diesel in Sweden and citydiesel in Finland) can cause a power reduction of approximately 5% and a decrease in fuel economy of approximately 2–3%.

Cooling system

General

	TAD1240-42GE TAD1241-42VE	TWD1240VE
Type	Overpressure, closed	
Pressure valve opens at.....	75 kPa (11 psi)	75 kPa(11 psi)
Volume (engine)	20 liters (5.3 US gal)	20 liters (5.3 US gal)
Volume (engine + radiator and hoses)	44 liters (11.6 US gal)	44 liters (11.6 US gal)

Thermostat

	TAD1240-42GE TAD1241-42VE	TWD1240VE
Type	Piston thermostat	Piston thermostat
Number	1	1
Opening temperature	82°C (187°F)	75°C (167°F)

Coolant filter

	TAD1240-42GE TAD1241-42VE	TWD1240VE
Number	1	1

Electrical system

System voltage	24 V
Alternator:	
voltage/max. current	28 V/60 A
power approx.	1700 W
Battery capacity	2 serial-connected 12 V, max. 152 Ah
Battery electrolyte density at +25°C:	
fully charged battery	1.28 g/cm ³ (1.24 g/cm ³)*
the battery discharges at	1.24 g/cm ³ (1.20 g/cm ³)*

* **Note:** Applies to batteries with tropical electrolyte.

Notes

A series of horizontal dotted lines for writing notes.

Notes

A series of horizontal dotted lines for writing notes.

ENG

Post or fax this coupon to:

Document & Distribution Center
Order Department
ARU2, Dept. 64620
SE-405 08 Göteborg
Sweden
Fax: +46 31 545 772

Orders can also be placed via the Internet:

<http://www.volvopenta.com/manual/coupon>

Yes please,

I would like an operator's manual in English at no charge.

Publication number: 7745138

Name

Address

Country

NB! This offer is valid for a period of 12 months from delivery of the boat. Availability after this period will be as far as supplies admit.

**VOLVO
PENTA**

42200/615001/155099900192

GER

Schicken Sie den Coupon per Post oder als Fax an:

Document & Distribution Center
Order Department
ARU2, Dept. 64620
SE-405 08 Göteborg
Schweden
Fax: +46 31 545 772

Die Bestellung kann auch über das Internet erfolgen:

<http://www.volvopenta.com/manual/coupon>

Ja,

ich will kostenlos eine Betriebsanleitung in deutscher Sprache erhalten.

Publikationsnummer: 7741213

Name

Anschrift

Land

Bitte beachten Sie, dass dieses Angebot für die Dauer von 12 Monaten ab dem Lieferdatum des Bootes gilt, danach bis zum Aufbrauchen des Lagerbestandes.

**VOLVO
PENTA**

42200/615001/155099900192

FRE

Envoyez ou faxez le bon de commande à:

Document & Distribution Center
Order Department
ARU2, Dept. 64620
SE-405 08 Göteborg
Suède
Fax: +46 31 545 772

Vous pouvez également passer la commande par Internet:

<http://www.volvopenta.com/manual/coupon>

Oui merci,

Je souhaite recevoir un manuel d'instructions gratuit en français.

Numéro de publication: 7741214

Nom

Adresse

Pays

Notez que l'offre est valable pendant 12 mois à partir de la date de livraison du bateau, ensuite seulement en fonction des stocks disponibles.

**VOLVO
PENTA**

42200/615001/155099900192

SPA

Franquear o enviar fax a:
Document & Distribution Center
Order Department
ARU2, Dept. 64620
SE-405 08 Göteborg
Suecia
Fax: +46 31 545 772

El pedido puede hacerse también por internet:
<http://www.volvopenta.com/manual/coupon>

Sí gracias,

deseo recibir gratuitamente un libro de instrucciones en español.

Número de publicación: 7741215

Nombre

Dirección

País

Nótese que el ofrecimiento vale durante 12 meses después de la fecha de entrega de la embarcación, y posteriormente solamente mientras duren las existencias.

**VOLVO
PENTA**

42200/615001/155099900192



ITA

Spedire il tagliando per posta o per fax a:

Document & Distribution Center
Order Department
ARU2, Dept. 64620
SE-405 08 Göteborg
Svezia
Fax: +46 31 545 772

L'ordinazione può essere fatta anche su Internet:
<http://www.volvopenta.com/manual/coupon>

Sì, grazie,

desidero ricevere gratuitamente un manuale d'istruzioni in lingua italiana.

Public. No.: 7741216

Nome e Cognome

Indirizzo

Paese

Si ricorda che l'offerta è valida per 12 mesi dalla data di consegna dell'imbarcazione; dopo il suddetto periodo l'offerta resta valida solo in base alla disposizione della pubblicazione in oggetto.

**VOLVO
PENTA**

42200/615001/155099900192



SWE

Posta eller faxes kupongen till:

Dokument & Distribution center
Ordermottagningen
ARU2, Avd. 64620
SE-405 08 Göteborg
Sverige
Fax: +46 31 545 772

Beställningen kan även göras via internet:
<http://www.volvopenta.com/manual/coupon>

Ja tack,

jag vill kostnadsfritt ha en instruktionsbok på svenska.

Publikationsnummer: 7741211

Namn

Adress

Land

Observera att erbjudandet gäller i 12 månader från båtens leveransdatum, därefter endast i mån av tillgång.

**VOLVO
PENTA**

42200/615001/155099900192

DUT

Stuur of fax de coupon naar:

Document & Distribution Center
Order Department
ARU2, Dept. 64620
SE-405 08 Göteborg
Zweden
Fax: +46 31 545 772

U kunt ook bestellen via internet:

[http://www.volvopenta.com/
manual/coupon](http://www.volvopenta.com/manual/coupon)

Ja graag,

Ik wil kosteloos een instructieboek in het Nederlands ontvangen.

Publicatienummer: 7741218

Naam

Adres

Land

*Denk eraan dat het aanbod geldt gedurende 12 maanden na de datum
waarop de boot werd afgeleverd, daarna alleen indien nog verkrijgbaar.*

**VOLVO
PENTA**

42200/615001/155099900192

FIN

Postita tai faksaa kuponki osoitteella:

Document & Distribution Center
Order Department
ARU2, Dept. 64620
SE-405 08 Göteborg
Ruotsi
Fax: +46 31 545 772

Tilauksen voi tehdä myös Internetissä:

[http://www.volvopenta.com/
manual/coupon](http://www.volvopenta.com/manual/coupon)

Kyllä kiitos,

haluan suomenkielisen ohjekirjan veloituksetta.

Julkaisunumero: 7741217

Nimi

Osoite

Maa

*Huomaa, että tarjous on voimassa 12 kuukautta veneen toimituspäivä-
määrästä lukien ja sen jälkeen vain niin kauan kuin kirjoja riittää.*

**VOLVO
PENTA**

42200/615001/155099900192

POR

Envie o talão pelo correio ou um fax para:

Document & Distribution Center
Order Department
ARU2, Dept. 64620
SE-405 08 Göteborg
Suécia
Fax: +46 31 545 772

A encomenda também pode ser feita através da Internet:

[http://www.volvopenta.com/
manual/coupon](http://www.volvopenta.com/manual/coupon)

Sim, obrigado(a)!

Gostaria de receber gratuitamente um manual de instruções em português.

Número de publicação: 7741219

Nome

Endereço

País

*Observar que esta oferta é válida durante um período de 12 meses a contar da
data de entrega do barco. Após este período, a oferta está dependente do nú-
mero de exemplares disponíveis.*

**VOLVO
PENTA**

42200/615001/155099900192

GRE

Ταχυδρομήστε αυτό το κουπόνι στην παρακάτω διεύθυνση ή στείλτε το με φαξ στον παρακάτω αριθμό φαξ:

Document & Distribution Center
Order Department
ARU2, Dept. 64620
SE-405 08 Göteborg
Sweden
Fax: +46 31 545 772

Μπορείτε επίσης να δώσετε την παραγγελία σας μέσω του Internet, στη διεύθυνση:
<http://www.volvopenta.com/manual/coupon>

Ναι,

Θα ήθελα ένα αντίτυπο του εγχειριδίου χρήσης στην αγγλική γλώσσα χωρίς καμιά χρέωση.

Αριθμός έκδοσης: 7741221

Όνομα

Διεύθυνση

Χώρα

ΠΡΟΣΟΧΗ: Αυτή η προσφορά ισχύει για χρονική περίοδο 12 μηνών από την παράδοση του σκάφους. Μετά το πέρας της εν λόγω χρονικής περιόδου η διαθεσιμότητα των αντιτύπων θα εξαρτάται από την ποσότητα των αποθεμάτων.

**VOLVO
PENTA**

42200/615001/155099900192

RUS

Отправьте этот талон почтой или факсом на имя:

Document & Distribution Center
Order Department
ARU2, Dept. 64620
SE-405 08 Göteborg
Sweden

Fax: +46 31 545 772

Заказы также можно размещать через Интернет:

<http://www.volvopenta.com/manual/coupon>

Да, пожалуйста,

Я бы хотел иметь бесплатное руководство оператора на русском языке.

Номер издания: 7741223

Имя

Адрес

Страна

Примечание: Данное предложение действительно в течение 12 месяцев с момента доставки двигателя. По истечении этого периода наличие товаров будет зависеть от их поступления.

**VOLVO
PENTA**

42200/615001/155099900192

VOLVO PENTA

AB Volvo Penta

SE-405 08 Göteborg, Sweden

www.volvopenta.com