

# PARTS AND OPERATION MANUAL

# MQ POWER DCA-125SSJU PORTABLE GENERATOR General Electric Equipment Rental (GEER)

© COPYRIGHT 2001, MULTIQIP INC.

S/N7500283 TO S/N7500468-1999 VERSION

S/N7500469~ 2000 VERSION

Revision #1 (03/14/01)



**MULTIQIP INC.**

18910 WILMINGTON AVE.  
CARSON, CALIFORNIA 90746  
310-537-3700  
800-421-1244  
FAX: 310-537-3927

E-mail: [mq@multiquip.com](mailto:mq@multiquip.com) • [www.multiquip.com](http://www.multiquip.com)

**PARTS DEPARTMENT:**

800-427-1244  
FAX: 800-672-7877

**SERVICE DEPARTMENT:**

800-835-2551  
FAX: 310-638-8046



# **WARNING**



## **CALIFORNIA--Proposition 65 Warning**

**Engine exhaust and some of its constituents are known to the State of California to cause cancer, birth defects and other reproductive harm.**

## **HERE'S HOW TO GET HELP**

*PLEASE HAVE THE MODEL AND SERIAL NUMBER  
ON-HAND WHEN CALLING*

### ***PARTS DEPARTMENT***

*800/427-1244 or 310/537-3700*

*FAX: 800/672-7877 or 310/637-3284*

### ***SERVICE DEPARTMENT***

*800/835-2551 or 310/537-3700*

*FAX: 310/638-8046*

### ***WARRANTY DEPARTMENT***

*800/835-2551 or 310/537-3700*

*FAX: 310/638-8046*

### ***MAIN***

*800/421-1244 or 310/537-3700*

*FAX: 310/537-3927*

# TABLE OF CONTENTS

Here's How To Get Help ..... 3  
Table Of Contents ..... 4  
Parts Ordering Procedures ..... 5  
Rules for Safe Operation ..... 6-9  
Towing Safety Precaution ..... 10  
Trailer Safety Guidelines ..... 11-17  
Trailer Wiring Diagram ..... 18  
Electric Brake Troubleshooting ..... 19  
Hydraulic Brake Troubleshooting ..... 20  
Operation and Safety Decals ..... 21-22  
DCA125 Specifications ..... 23

## **MQPower DCA 125SSJU AC Generator**

General Information ..... 24-26  
Major Components ..... 28  
Dimensions ..... 29  
Control Panel Descriptions ..... 30-31  
Engine Operating Panel Descriptions ..... 32-35  
Output Terminal Panel Descriptions ..... 36-37  
Installation ..... 38-39  
Pre Set-up ..... 40-43  
Load Application ..... 44  
Generator Start-up Procedure, Manual ..... 45-48  
Generator Start-up Procedure, Auto ..... 49  
Generator Shut-Down Procedure ..... 50  
Maintenance ..... 52-53  
Generator Wiring Diagram ..... 54  
Engine Troubleshooting ..... 56-57  
Generator/Engine Troubleshooting ..... 58  
MPEC Troubleshooting ..... 59  
Explanation of Code in Remarks Column ..... 60  
Suggested Spare Parts ..... 61

Generator Assembly ..... 62-63  
Control Panel Assembly -2000 Verson ..... 64-67  
Control Panel Assembly-1999 Verson ..... 68-69  
Engine & Radiator Assembly-2000 Version ..... 70-73  
Engine & Radiator Assembly-1999 Version ..... 74-77  
Engine Operating Panel Assembly-2000 Version ..... 78-79  
Engine Operating Panel Assembly-1999 Version ..... 80-81  
Output Terminal Assembly ..... 82-85  
Battery Assembly ..... 86-87  
Muffler Assembly ..... 88-89  
Fuel Water Separator Assembly-2000 Version ..... 90-91  
Fuel-Water Separator Assembly-1999 Version ..... 92-93  
Enclosure Assembly ..... 94-97  
Rubber Seal Assembly ..... 98-99  
Name Plate And Decals ..... 100-101  
  
Terms and Condition of Sale — Parts ..... 102

**NOTE**

*Specification and part number  
are subject to change without  
notice.*

- Dealer account number
- Dealer name and address
- Shipping address (if different than billing address)
- Return fax number
- Applicable model number
- Quantity, part number and description of each part
- Specify preferred method of shipment:
  - UPS Ground
  - UPS Second Day or Third Day\*
  - UPS Next Day\*
  - Federal Express Priority One (please provide us with your Federal Express account number)\*
  - Airborne Express\*
  - Truck or parcel post

*\*Normally shipped the same day the order is received, if prior to 2PM west coast time.*

## Earn Extra Discounts when you order by FAX!

All parts orders which include complete part numbers and are received by fax qualify for the following extra discounts:

Number of line items ordered	Additional Discount
1-9 items	3%
10+ items**	5%

### Get special freight allowances when you order 10 or more line items via FAX! \*\*

- UPS Ground Service at no charge for freight
- PS Third Day Service at one-half of actual freight cost

No other allowances on freight shipped by any other carrier.

\*\*Common nuts, bolts and washers (all items under \$1.00 list price) do not count towards the 10+ line items.

\*DISCOUNTS ARE SUBJECT TO CHANGE\*

Fax order discount and UPS special programs revised June 1, 1995

**Extra Fax Discount  
for Domestic USA  
Dealers Only**

**Up to 5%  
extra savings!**

**UPS  
Special**  
For faxed orders only

**Now! Direct TOLL-FREE access  
to our Parts Department!**

**Toll-free nationwide:**

**800-421-1244**

**Toll-free FAX:**

**800/6-PARTS-7 • 800-672-7877**

# RULES FOR SAFE OPERATION

## CAUTION:



Failure to follow instructions in this manual may lead to serious injury or even death! This equipment is to be operated by trained and qualified personnel only! This equipment is for industrial use only.

The following safety guidelines should always be used when operating the DCA-125SSJU portable generator:

### GENERAL SAFETY

- **DO NOT** operate or service this equipment before reading this entire manual.



- This equipment should not be operated by persons under 18 years of age.

- **NEVER** operate this equipment without proper protective clothing, shatterproof glasses, steel-toed boots and other protective devices required by the job.



- **NEVER** operate this equipment when not feeling well due to fatigue, illness or taking medicine.



- **NEVER** operate this equipment under the influence of drugs or alcohol.



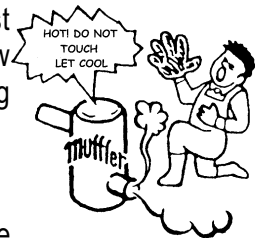
- **NEVER** use accessories or attachments, which are not recommended by MQ Power for this equipment. Damage to the equipment and/or injury to user may result.

- Manufacturer does not assume responsibility for any accident due to equipment modifications.

- Whenever necessary, replace nameplate, operation and safety decals when they become difficult read.

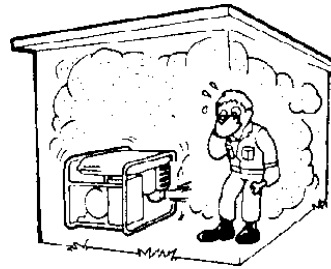
- Always check the machine for loosened threads or bolts before starting.

- **NEVER** touch the hot exhaust manifold, muffler or cylinder. Allow these parts to cool before servicing engine or generator.



- **High Temperatures** – Allow the engine to cool before adding fuel or performing service and maintenance functions. Contact with *hot* components can cause serious burns.

- The engine of this generator requires an adequate free flow of cooling air. Never operate the generator in any enclosed or narrow area where free flow of the air is restricted. If the air flow is restricted it will cause serious damage to the generator or engine and may cause injury to people. The generator engine gives off **DEADLY** carbon monoxide gas.



## CAUTION:



Always refuel in a well-ventilated area, away from sparks and open flames.

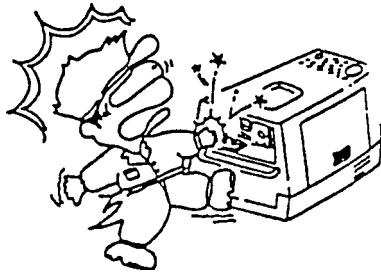


Always use extreme caution when working with **flammable** liquids. When refueling, **stop the engine** and allow it to cool. **DO NOT smoke** around or near the machine. Fire or explosion could result from fuel vapors, or if fuel is spilled on a hot engine.

- **NEVER** operate the generator in an explosive atmosphere or near combustible materials. An explosion or fire could result causing severe *bodily harm or even death*.
- Topping-off to filler port is dangerous, as it tends to spill fuel.

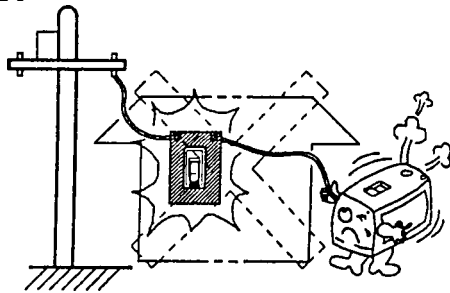
# RULES FOR SAFE OPERATION

## CAUTION:



■ **NEVER** touch output terminals during operation. This is extremely dangerous. Always stop the machine when contact with the output terminals.

## CAUTION:



■ **Backfeed** to a utility system can cause electrocution and/or property damage. Do not connect to any building's electrical system except through an approved device or after building main switch is opened.

## CAUTION:



■ **Never** use damaged or worn cables when connecting power tools or equipment to the generator. Make sure power connecting cables are securely connected to the generator's output terminals, insufficient tightening of the terminal connections may cause damage to the generator and electrical shock.

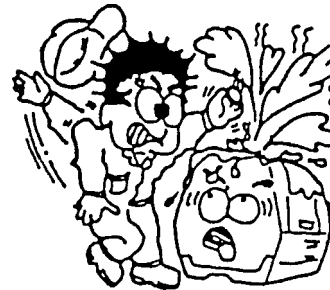
## CAUTION:



**DO NOT** touch or open any of the below mentioned components while the generator is running. Always allow sufficient time for the engine and generator to cool before performing maintenance.

### Radiator

1. **Radiator Cap** - Removing the radiator cap while the engine is hot will result in high pressurized, boiling water to gush out of the radiator, therefore causing severe scalding to any persons in the general area of the generator.



2. **Coolant Drain Plug** - Removing the coolant drain plug while the engine is hot will result in hot coolant to gush out of the coolant drain plug, therefore causing severe scalding to any persons in the general area of the generator.
3. **Engine Oil Drain Plug** - Removing the engine oil drain plug while the engine is hot will result in hot oil to gush out of the oil drain plug, therefore causing severe scalding to any persons in the general area of the generator.

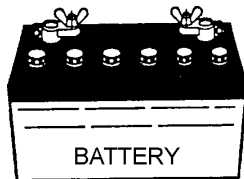
## Battery

### CAUTION:



- Never over fill the battery with water above the upper limit.

The battery contains acids that can cause injury to the eyes and skin. To avoid eye irritation, always wear safety glasses. Use well insulated gloves when picking up the battery. Use the following guidelines when handling the battery:



1. **DO NOT** drop the battery. There is the possibility of risk that the battery may explode.
  2. **DO NOT** expose the battery to open flames, sparks, cigarettes etc. The battery contains combustible gases and liquids. If these gases and liquids come in contact with a flame or spark, an explosion could occur.
  3. Always keep the battery charged. If the battery is not charged a buildup of combustible gas will occur.
  4. Always keep battery charging and booster cables in good working condition. Repair or replace all worn cables.
  5. Always recharge the battery in an open air environment, to avoid risk of a dangerous concentration of combustible gases.
  6. In case the battery liquid (dilute sulfuric acid) comes in contact with **clothing or skin**, rinse skin or clothing immediately with plenty of water.
  7. In case the battery liquid (dilute sulfuric acid) comes in contact with your **eyes**, rinse eyes immediately with plenty of water, then contact the nearest doctor or hospital, and seek medical attention.
- **NEVER** Run engine without air filter. Severe engine damage may occur.
  - Always service air cleaner frequently to prevent carburetor malfunction.
  - Always disconnect the battery before performing service on the generator.
  - Always be sure the operator is familiar with proper safety precautions and operations techniques before using generator.
  - Always store equipment properly when not in use. Equipment should be stored in a clean, dry location out of the reach of children.
  - **DO NOT** leave the generator running in the manual mode unattended.
  - **DO NOT** allow unauthorized people to operate this equipment.
  - Always read, understand, and follow procedures in Operator's Manual before attempting to operate equipment.
  - Refer to the **Komatsu Engine Owner's Manual** for engine technical questions or information.

### Loading and Unloading (Crane)

- Before lifting, make sure the generator's lifting hook is secure and that there is no apparent damage to the generator itself (loose screws, nuts and bolts). If any part is loose or damaged, please take corrective action before lifting.
- Always drain fuel prior to lifting.
- Always make sure crane or lifting device has been properly secured to the hook of guard frame on generator.
- **NEVER** lift the machine while the engine is running.
- Use adequate lifting cable (wire or rope) of sufficient strength.
- When lifting the generator, always use the balanced center-point suspension hook and lift straight upwards.
- **NEVER** allow any person or animal to stand underneath the machine while lifting.
- When loading the generator on a truck, be sure to use the front and back frame bars as a means to secure the generator during transport.

## Transporting

- Always shutdown engine before transporting.
- Tighten fuel tank cap securely.
- Drain fuel when transporting generator over long distances or bad roads.
- Always tie-down the generator during transportation by securing the generator.
- If generator is mounted on a trailer, make sure trailer complies with all local and state safety transportation laws. See page 10 for basic towing procedures.

## Emergencies

- Always know the location of the nearest **fire extinguisher** and **first aid kit**. Know the location of the nearest telephone. Also know the phone numbers of the nearest **ambulance**, **doctor** and **fire department**.

## Maintenance Safety

- **NEVER** lubricate components or attempt service on a running machine.
- Always allow the machine a proper amount of time to cool before servicing.
- Keep the machinery in proper running condition.
- Fix damage to the machine immediately and always replace broken parts.
- Dispose of hazardous waste properly. Examples of potentially hazardous waste are used motor oil, coolant, fuel, and fuel filters.
- **DO NOT** use plastic containers to dispose of hazardous waste.
- **DO NOT** pour waste, oil, coolant or fuel directly onto the ground, down a drain or into any water source

## Towing Safety Precautions

### CAUTION :



Check with your county or state safety towing regulations department before towing your generator.

To reduce the possibility of an accident while transporting the generator on public roads, always make sure the trailer (Figure 1) that supports the generator and the towing vehicle are in good operating condition and both units are mechanically sound.

The following list of suggestions should be used when towing your generator:

- Make sure the hitch and coupling of the towing vehicle are rated equal to, or greater than the trailer "gross vehicle weight rating" (GVWR).
- **ALWAYS** inspect the hitch and coupling for wear. **NEVER** tow a trailer with defective hitches, couplings, chains etc.
- Check the tire air pressure on both towing vehicle and trailer. Also check the tire tread wear on both vehicles.
- **ALWAYS** make sure the trailer is equipped with a "Safety Chain".

- **ALWAYS** attach trailer's safety chain to bumper of towing vehicle.
- **ALWAYS** make sure the vehicle and trailer directional, backup, brake, and trailer lights are connected and working properly.
- Remember the maximum speed unless otherwise posted for highway towing is **45 MPH**. Recommended off-road towing is not to exceed **10 MPH** or less depending on type of terrain.
- Place *chocked blocks* underneath wheel to prevent **rolling**, while parked.
- Place *support blocks* underneath the trailer's bumper to prevent **tipping**, while parked.
- Use the trailer's hand winch to adjust the height of the trailer, then insert locking pin to lock wheel stand in place, while parked.
- Avoid sudden stops and starts. This can cause skidding, or jackknifing. Smooth, gradual starts and stops will improve gas mileage.
- Avoid sharp turns to prevent rolling.
- Remove wheel stand when transporting.
- **DO NOT** transport generator with fuel in tank.

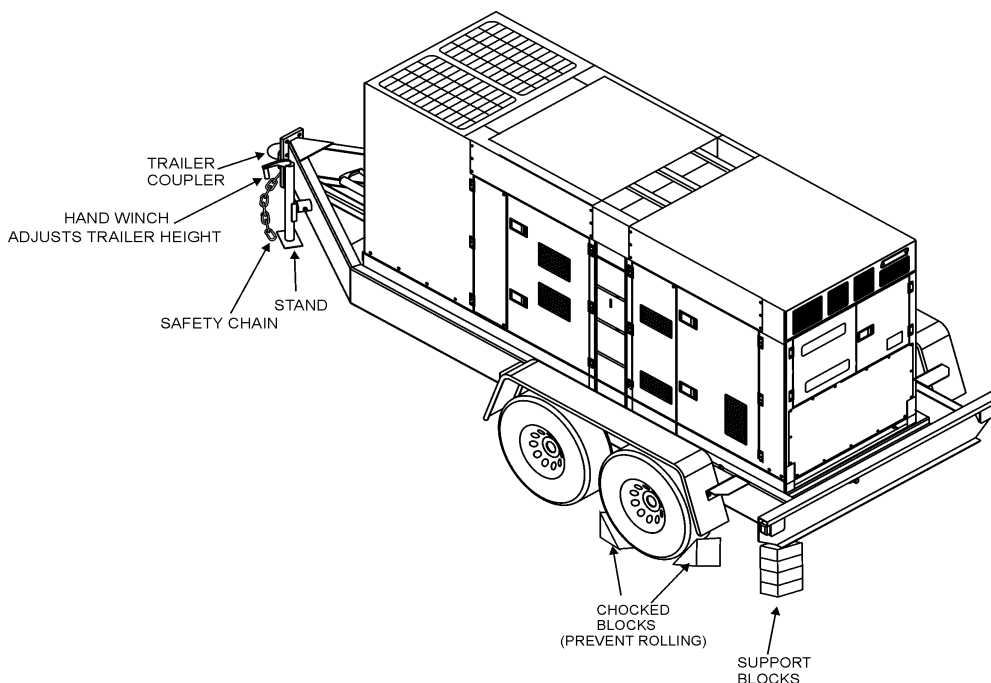


Figure 1. Generator with Trailer

## CAUTION:



**ALWAYS** make sure the trailer is in good operating condition. Check the tires for proper inflation and wear. Also check the wheel lug nuts for proper tightness.

### Explanation of Chart:

This section is intended to provide the user with trailer service and maintenance information. The service and maintenance guidelines referenced in this section apply a wide range of trailers. Remember periodic inspection of the trailer will ensure safe towing of the equipment and will prevent damage to the equipment and personal injury.

It is the purpose of this section to cover the major maintenance components of the trailer. The following trailer components will be discussed in this section:

- Brakes
- Tires
- Lug Nut Torquing
- Suspension
- Electrical
- Brake Troubleshooting Tables

Use the following definitions with reading Table 1.

1. **Fuel Cell** - Provides an adequate amount of fuel for the equipment in use. fuel cells must be empty when transporting equipment.
2. **Braking System** - System employed in stopping the trailer. Typical braking systems are electric, surge, hydraulic, hydraulic-surge and air.
3. **GVWR**- Gross Vehicle Weight Rating (GVWR), is the maximum number of pounds the trailer can carry, including the fuel cell (empty).
4. **Frame Length** - This measurement is from the ball hitch to the rear bumper (reflector).
5. **Frame Width** - This measurement is from fender to fender.
6. **Jack Stand** - Trailer support device with maximum pound requirement from the tongue of the trailer.
7. **Coupler** - Type of hitch used on the trailer for towing.
8. **Tire Size** - Indicates the diameter of the tire in inches (10,12,14, etc.), and the width in millimeters (175,185,205, etc.). The tire diameter must match the diameter of the tire rim.
9. **Tire Ply** - The tire ply (layers) number is rated in letters; 2-ply,4-ply,6-ply, etc.
10. **Wheel Hub** - Thr wheel hub is connected to the trailer's axle.
11. **Tire Rim** - Tires mounted on a tire rim. The tire rim must match the size of the tire.
12. **Lug Nuts** - Used to secure the wheel to the wheel hub. Always use a torque wrench to tighten down the lug nuts. See Table 4 and Figure 5 or lug nut tightening and sequence.
13. **Axle** - Indicates the maximum weight the axle can support in pounds, and the diameter of the axle expressed in inches (see Table 3). Please not that some trailers have a double axle. this will be shown as 2-6000 lbs., meaning two axles with a total weight capacity of 6000 pounds.
14. **Suspension** - Protects the trailer chassis from shocks transmitted through the wheels. Types of suspension used are leaf, Q-flex, and air ride.
15. **Electrical** - Electrical connectors (looms) are provided with the trailer so the brake lights and turn signals can be connected to the towing vehicle. See Figure 19 for proper wiring connections.
16. **Application** - Indicates which units can be employed on a particular trailer.

# DCA-125SSJU —TRAILER-SPECIFICATIONS

**Table 1. Specifications**

MODEL	APPLICATION	FUEL CELL	BRAKE SYSTEM	GVWR	FRAME LENGTH	FRAME WIDTH	JACK STAND
TRLR-10-15	TLG-12, DCA15, TLW-300	NO	NO	1900LBS	96"	50"	800LB. FULL TILT WHEEL
TRLR-10X	TLG-12, DCA15, TLW-300	NO	NO	1900LBS	96"	50"	800LB. FULL TILT WHEEL
TRLR-10XF	TLG-12, DCA15, TLW-300	51 GAL	NO	1900LBS	96"	50"	800LB. FULL TILT WHEEL
TRLR-225W	DCA-10	NO	NO	2200LBS	85"	42"	800LB. FULL TILT WHEEL
BLW-400	BLW-400	NO	ELECTRIC	2700LBS	W/MAST 154" W/O 124"	55" (78" TALL)	800LB. FULL TILT WHEEL
TRLR-15XF	DCA-15	41 GAL	NO	2700LBS	124"	55"	800LB. FULL TILT WHEEL
TRLR-50X	DCA-25	NO	NO	2700LBS	124"	55"	800LB. FULL TILT WHEEL
TRLR-50XF	DCA-25	41 GAL	NO	2700LBS	124"	55"	800LB. FULL TILT WHEEL
TRLR-25SBT	DCA-25	NO	NO	2990LBS	120"	66"	800LB. FULL TILT WHEEL
TRLR-70W	DCA-45, -60, 70	NO	SURGE	7000LBS	186"	77"	2000LB. FLAT PAD
TRLR-70X	DCA-45, -60, 70	OPT	SURGE	7000LBS	138"	66"	2000LB. FLAT PAD
TRLR-70XF	DCA-45, -60, 70	53 GAL	SURGE	7000LBS	138"	66"	2000LB. FLAT PAD
TRLR-100XF	DCA-100, 125	150 GAL	HYDRAULIC SURGE	7000LBS	190"	76"	2000LB. FLAT PAD
TRLR-85/125	DCA-85, 100, 125	145 GAL	HYDRAULIC	10000LBS	186"	77"	2000LB. FLAT PAD
TRLR-150XF	DCA-150, 180	200 GAL	HYDRAULIC SURGE	11160LBS	204"	84"	5000 LB. FLAT PAD
TRLR-220XF	DCA-220	250 GAL	HYDRAULIC SURGE	14000LBS	222"	83"	5000 LB. FLAT PAD
TRLR-300XF	DCA-300	250 GAL	HYDRAULIC SURGE	18000LBS	238"	83"	5000 LB. FLAT PAD
TRLR-400XF	DCA-400	350 GAL	ELECTRIC	18000LBS	238"	83"	5000 LB. FLAT PAD
TRLR-600XF	DCA-600, 800	550 GAL	AIR	30000LBS	384"	96"	5000 LB. FLAT PAD
TRLR-800SX	DCA-600, 800	550 GAL	AIR	30000LBS	384"	96"	5000 LB. FLAT PAD

# DCA-125SSJU —TRAILER-SPECIFICATIONS

**Table 1. Specifications (Con't)**

MODEL	COUPLER	TIRES	WHEELS	AXLE	HUBS	SUSPENSION	ELECTRICAL
TRLR-10-15W	2" BALL CLASS 2 ADJUSTABLE	175-13C	13"X4.50"	2200# 2X2	5 LUG	3 LEAF	4 WIRE LOOM W/ 4 POLE FLAT
TRLR-10X	2"BALL CLASS 2 ADJUSTABLE	175-13C	13"X4.5"	2200#2X2	5 LUG	3 LEAF	4 POLE FLAT
TRLR-10XF	2"BALL CLASS 2 ADJUSTABLE	175-13C	13"X4.5"	2200#2X2	5 LUG	3 LEAF	4 POLE FLAT
TRLR-225W	2"BALL CLASS 2 ADJUSTABLE	175-13B	13X4.5"	2200#2X2	5 LUG	Q FLEX	4 POLE FLAT
BLW 400	2"BALL CLASS 2 ADJUSTABLE	175-13C	13 X 4.5"	2200#2X2	5 LUG	3 LEAF	4 POLE FLAT
TRLR-15XF	2" BALL CLASS	B78-13LRC	13"X4.50"	3500# 2-1/2"	5 LUG	4 LEAF	4 POLE RUBBER FLAT
TRLR-50X	2" BALL CLASS	B78-13LRC	13"X4.50"	3500lbs. 2-3/8"	5 LUG	4 LEAF	4 POLE RUBBER FLAT
TRLR-50XF	2" BALL CLASS	B78-13LRC	13"X4.50"	3500lbs. 2-3/8"	5 LUG	4 LEAF	4 POLE RUBBER FLAT
TRLR-70W	2" BALL CLASS 3" ADJUSTABLE	205-14C BIAS (4)	14"X5"	3500lbs. 3"	5 LUG	5 LEAF	4 POLE RUBBER FLAT
TRLR-70X	2" BALL CLASS 3" ADJUSTABLE	205-14C BIAS (4)	14"X5"	3500lbs 3"	5 LUG	5 LEAF	4 POLE RUBBER FLAT
TRLR-70XF	2" BALL CLASS 3" ADJUSTABLE	205-14C BIAS (4)	14"X5"	3500lbs. 3"	5 LUG	5 LEAF	4 POLE RUBBER FLAT
TRLR-100XF	ADJUSTABLE 2-5/6 OPT 3" EYE	205-15C BIAS (4)	14"X5.5"	3500lbs 3"	5 LUG	5 LEAF	4 WIRE LOOM
TRLR-85/125	ADJUSTABLE 2-5/6 OPT 3" EYE	ST225/75R15D RADIAL (4)	14"x6"	(2)-6000lbs	6 LUG	7 LEAF	4 WIRE LOOM
TRLR-150XF	3" BALL EYE	750-16 E BIAS (4)	16"X7"	(2)-6000lbs	8 LUG	7 LEAF	4 WIRE LOOM
TRLR-220XF	3" EYE ADJUSTABLE	ST235/85R16E RADIAL(4)	16"X7"	(2)-7000lbs	8 LUG	Q FLEX	4 WIRE LOOM
TRLR-300XF	3" EYE ADJUSTABLE	ST235/85R16E RADIAL(6)	16"X7"	(2)-6000lbs	8 LUG	Q FLEX	4 WIRE LOOM
TRLR-400XF	3" EYE ADJUSTABLE	ST235/85R16E RADIAL(6)	16"X7"	(3)-7000lbs.	8 LUG	Q FLEX	4 WIRE LOOM
TRLR-600XF	5TH WHEEL	ST215/75R17.5H RADIAL (8)	16"X7"	(3)-10000lbs	8 LUG	7 LEAF	6 WIRE LOOM
TRLR-800AR	5TH WHEEL	ST215/75R17.5H RADIAL (8)	16"X7"	(3)-10000lbs	8 LUG	AIR-RIDE	6 WIRE LOOM

## Brakes

If your trailer has a braking system, the brakes should be inspected the first 200 miles of operation. This will allow the brake shoes and drums to seat properly. After the first 200 mile interval, inspect the brakes every 3,000 miles. If driving over rough terrain, inspect the brakes more frequently.

## Electric Brakes

Electrically actuated brakes (Figure 2) are similar to hydraulic brakes. The basic difference is that hydraulic brakes are actuated by an electromagnet.

Listed below are some of the advantages that electric brakes have over hydraulic brakes:

- Brake system can be manually adjusted to provide the corrected braking capability for varying road and load conditions
- Brake system can be modulated to provide more or less braking force, thus easing the brake load on the towing vehicle
- Brake system has very little lag time between the time the vehicle's brakes are actuated and the trailer's brakes are actuated
- Brake system can provide an independent emergency brake system

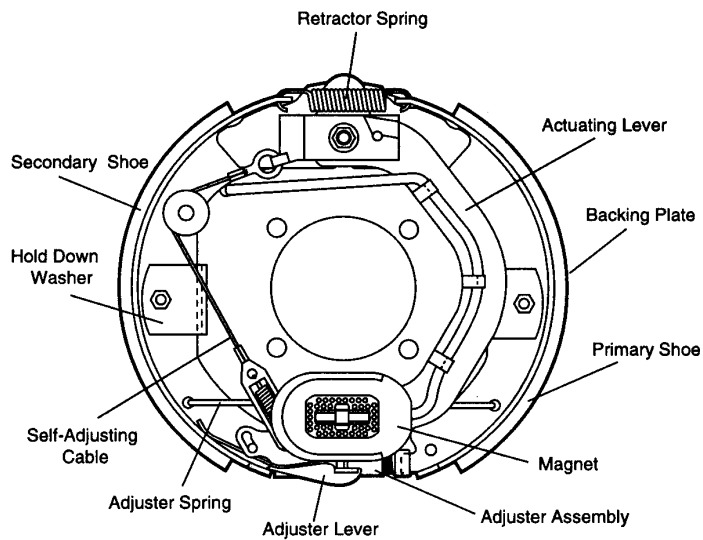
Remember in order to properly synchronize the tow vehicle's braking to the trailer's braking, can only be accomplished by road testing. Brake lockup, grabbiness or harshness is due to lack of synchronization between the tow vehicle and the trailer being towed or under-adjusted brakes.

Before any brake synchronizations adjustments can be made, the trailer brakes should be burnished-in by applying the brakes 20-30 times with approximately a 20 m.p.h. decrease in speed, e.g. 40 m.p.h. to 20 m.p.h. Allow ample time for brakes to cool between application. This allows the brake shoes to slightly be seated into the brake drum surface.

Figure 2 displays the major electric brake components that will require inspection and maintenance. Please inspect these components as required.

## Electric Brake Adjustment

1. Place the trailer on jack stands. Make sure the jack stands are placed on secure level ground.
2. Check the wheel and drum for free rotation.
3. Remove the adjusting hole cover from the adjusting slot at the bottom brake backing plate.
4. With a screwdriver or standard adjusting tool, rotate the star wheel of the adjuster assembly to expand the brake shoes.
5. Adjust the brake shoes outward until the pressure of the lining against the wheel drum makes the wheel difficult to turn.
6. Rotate the star wheel in the opposite direction until the wheel rotates freely with slight lining drag.
7. Replace the adjusting hole cover and lower the trailer to the ground.
8. Repeat steps 1 through 6 on the remaining brakes.

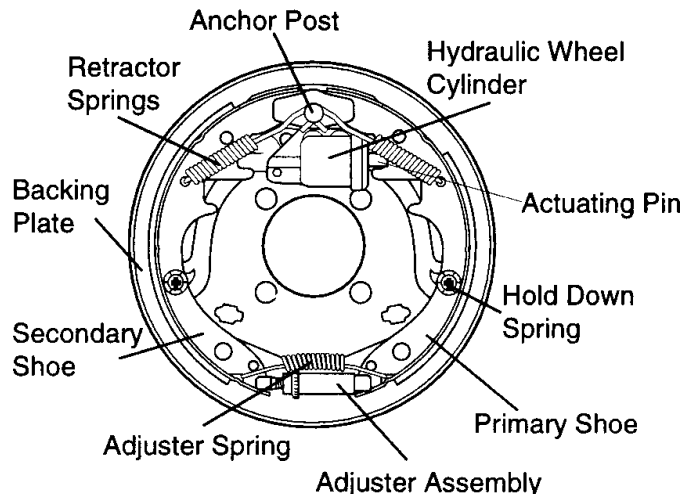


**Figure 2. Electrical Brake Components**

### Hydraulic/Air/Surge Brakes

Hydraulic brakes (Figure 3) should not require any special attention with the exception of routine maintenance such as shoe and lining replacement. These brakes can be adjusted in the same manner as electric brakes. Brake lines should be periodically checked for cracks, kinks, or blockage.

Figure 3 below displays the major hydraulic/air/surge brake components that will require inspection and maintenance. Please inspect these components as required using steps 1 through 6 as referenced in the electric brake adjustments section.



**Figure 3. Hydraulic Brake Components**

## Tires/Wheels/Lug Nuts

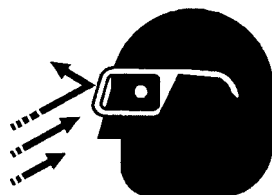
Tires and wheels are a very important and critical components of the trailer. When specifying or replacing the trailer wheels it is important the wheels, tires, and axle are properly matched.

### CAUTION:



DO NOT attempt to repair or modify a wheel. DO NOT install in inner tube to correct a leak through the rim. If the rim is cracked, the air pressure in the inner tube

may cause pieces of the rim to explode (break off) with great force and cause serious eye or bodily injury.



### Tire Wear/Inflation

Tire inflation pressure is the most important factor in tire life. Pressure should be checked cold before operation DO NOT bleed air from tires when they are hot. Check inflation pressure weekly during use to insure the maximum tire life and tread wear.

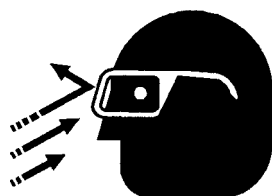
Table 2 (Tire Wear Troubleshooting) will help pinpoint the causes and solutions of tire wear problems.

WEAR PATTERN		CAUSE	SOLUTION
	Center Wear	Over Inflation.	Adjust pressure to particular load per tire manufacturer.
	Edge Wear	Under Inflation.	Adjust pressure to particular load per tire manufacturer.
	Side Wear	Loss of camber or overloading.	Make sure load does not exceed axle rating. Align wheels.
	Toe Wear	Incorrect toe-in.	Align wheels.
	Cupping	Out-of-balance.	Check bearing adjustment and balance tires.
	Flat Spots	Wheel lockup & tire skidding.	Avoid sudden stops when possible and adjust brakes.

## Suspension

The leaf suspension springs and associated components (Figure 4) should be visually inspected every 6,000 miles for signs of excessive wear, elongation of bolt holes, and loosening of fasteners. Replace all damaged parts (suspension) immediately. Torqued suspension components as detailed in Table 3.

### CAUTION:



#### NOTE

ALWAYS wear safety glasses when removing or installing force fitted parts. Failure to comply may result in serious injury.

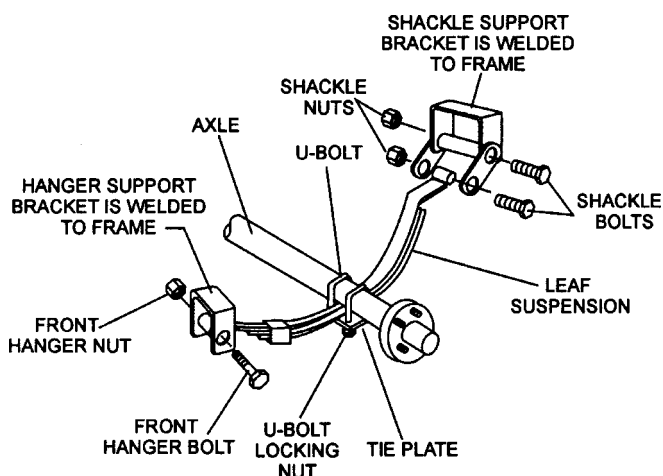


Figure 4. Major Suspension Components

**Table 3. Suspension Torque Requirements**

Item	Torque (Ft.-Lbs.)
3/8" U-BOLT	MIN-30 MAX-35
7/16" U-BOLT	MIN-45 MAX-60
1/2" U-BOLT	MIN-45 MAX-60
SHACKLE BOLT SPRING EYE BOLT	SNUG FIT ONLY. PARTS MUST ROTATE FREELY. LOCKING NUTS OR COTTER PINS ARE PROVIDED TO RETAIN NUT-BOLT ASSEMBLY.
SHOULDER TYPE SHACKLE BOLT	MIN-30 MAX-50

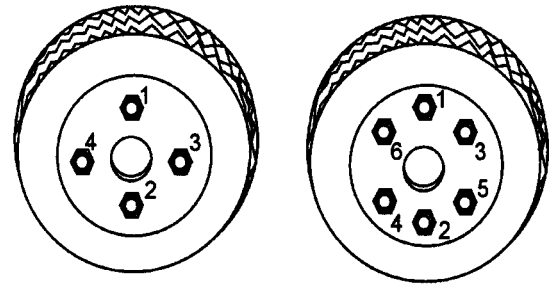
### Lug Nut Torque Requirements

It is extremely important to apply and maintain proper wheel mounting torque on the trailer. Be sure to use only the fasteners matched to the cone angle of the wheel. Proper procedure for attachment of the wheels is as follows:

1. Start all wheel lug nuts by hand.
2. Torque all lug nuts in sequence. See Figure 5. DO NOT torque the wheel lug nuts all the way down. Tighten each lug nut in 3 separate passes as defined by Table 4.
3. After first road use, retorque all lug nuts in sequence. Check all wheel lug nuts periodically.

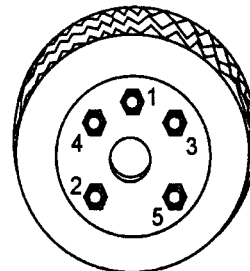
**Table 4. Tire Torque Requirements**

Wheel Size	First Pass FT-LBS	Second Pass FT-LBS	Third Pass FT-LBS
12"	20-25	35-40	50-65
13"	20-25	35-40	50-65
14"	20-25	50-60	90-120
15"	20-25	50-60	90-120
16"	20-25	50-60	90-120

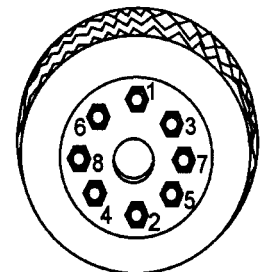


4-LUG NUTS

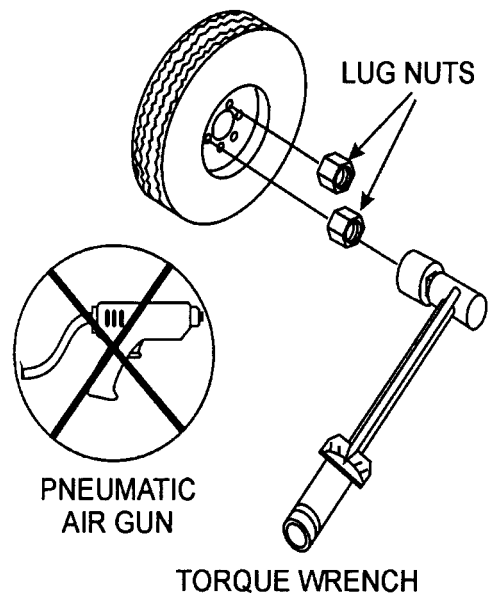
6-LUG NUTS



5-LUG NUTS



8-LUG NUTS



**Figure 5. Wheel Lug Nuts Tightening Sequence**

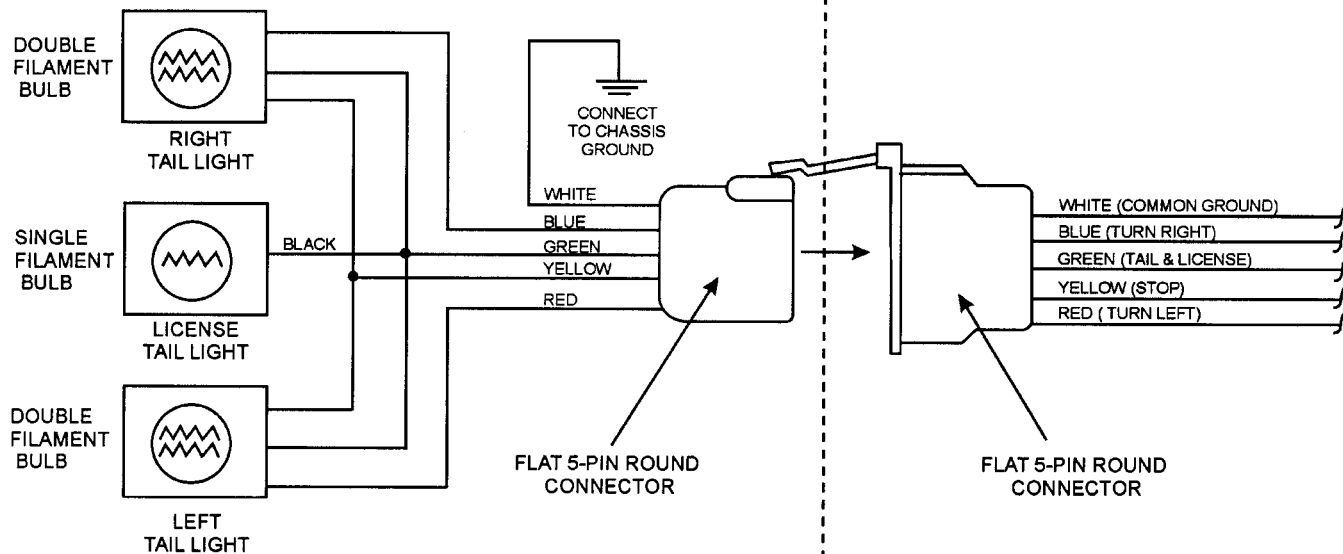
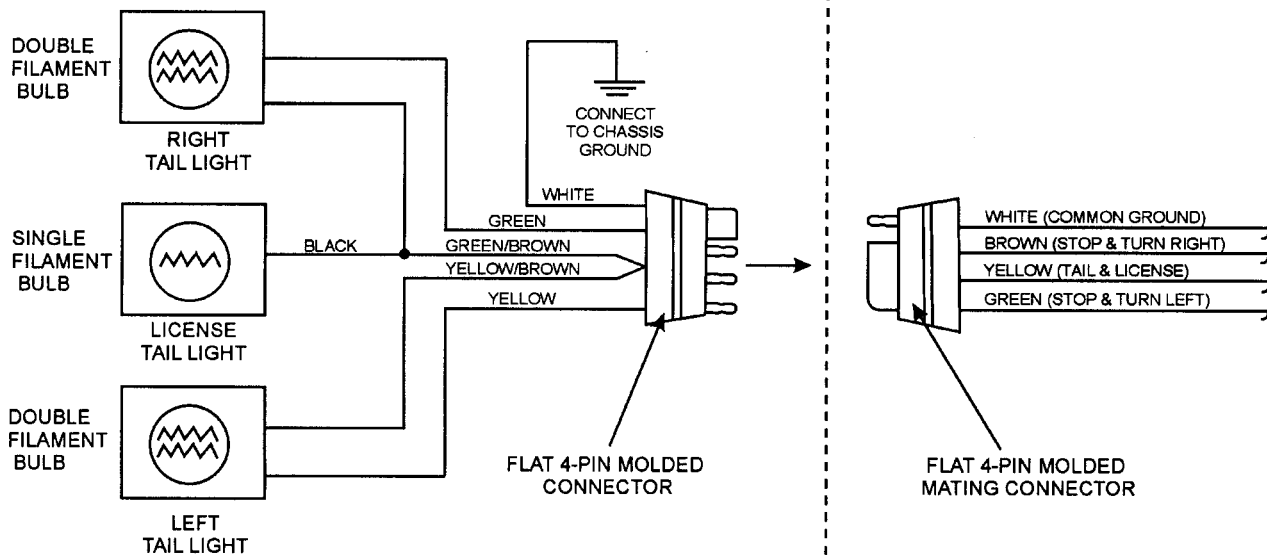
**NOTE**

NEVER use an pneumatic air gun to tighten wheel lug nuts.

# DCA-125SSJU — TRAILER WIRING DIAGRAM

## TRAILER SIDE

## TOWING VEHICLE SIDE



**NOTE:**  
LIGHTS ARE ORIENTED FROM THE DRIVER'S SEAT

# DCA-125SSJU —TRAILER-BRAKE TROUBLESHOOTING

**Table 5. Electric Brake Troubleshooting**

Symptom	Possible Cause	Solution
No Brakes or Intermittent Brakes	Any open circuits or broken wires?	Find and correct.
	Any short circuits?	Find and correct.
	Faulty controller?	Test and correct.
	Any loose connections?	Find and repair.
	Ground wire secure?	Find and secure.
Weak Brakes or Brakes Pull to One Side	Grease or oil on magnets or linings?	Clean or replace.
	Connections corroded?	Clean and correct cause of corrosion.
	Brake drums scored or grooved?	Machine or replace.
	Brakes synchronized?	Correct.
Locking Brakes	Brake components loose, bent or broken?	Replace components.
	Brake drums out-of-round?	Replace.
Noisy Brakes	System lubricated?	Lubricate.
	Brake components correct?	Replace and correct.
Dragging Brakes	Bearings of the wheel adjusted?	Adjust.

**Table 6. Hydraulic Brake Troubleshooting**

Symptom	Possible Cause	Solution
No Brakes	Brake line broken or kinked?	Repair or replace.
Weak Brakes or Brakes Pull to One Side	Brake lining glazed?	Reburnish or replace.
	Trailer overloaded?	Correct weight.
	Brake drums scored or grooved?	Machine or replace.
	Tire pressure correct?	Inflate all tires equally.
	Tires unmatched on the same axle?	Match tires.
Locking Brakes	Brake components loose, bent or broken?	Replace components.
	Brake drums out-of-round?	Replace.
Noisy Brakes	System lubricated?	Lubricate.
	Brake components correct?	Replace and correct.
Dragging Brakes	Brake lining thickness correct or in right wrong position?	Install new shoes and linings.
	Enough brake fluid or correct fluid?	Replace rubber parts fill with dot4 fluid.

# DCA-125SSJU —OPERATION AND SAFETY DECALS

## Machine Safety Decals

The DCA-125SSJU generator is equipped with a number of safety decals. These decals are provided for operator safety and maintenance information. The illustration below and on the preceding pages shows the decals as they appear on the machine. Should any of these decals become unreadable, replacements can be obtained from your dealer.

**OPERATING PROCEDURES**

**Manual Starting**

1. Check the engine oil, coolant, and fuel levels. Replenish if necessary.
2. Place all Generator Circuit Breakers in the "OFF" position and close all doors.
3. Check that the Voltage select switch (or the Voltage change-over board) is preset at desired voltage.  
(In case of generator having multiple voltage ratings.)
4. Set the Engine speed switch to the "LOW" position.
5. Turn the Auto-Off/Reset-Manual switch to the "Manual" position to start the engine. If the engine fails to start in the specified number of attempts, the overcrank lamp will indicate and the Auto-Off/Reset-Manual switch must be returned to the "Off/Reset" position before proceeding.
6. When the engine is ready for starting during cold weather operating conditions, push the Intake heater button for approximately 30 seconds. Start engine using the Auto-Off/Reset-Manual switch to the "Manual" position. As soon as the engine starts, release the button.
7. If the engine still does not start, utilize the water heater and water is warm (if additional water heater is supplied).
8. After starting, allow the engine to run for 1 or 2 minutes to warm up. All temperatures below freezing, this time period must be extended to 2 to 4 minutes.
9. When the engine starts, immediately check for abnormal noise, vibration, fluid leakage or any indication of a problem. Check the control panel gauges. If all is normal, let the engine remain in the "Low" position for a short time, depending on the ambient conditions, warm up.
10. After sufficient warm-up time has elapsed, set the Engine speed switch to the "High" position and the unit is ready for operation.
11. Check the NO2 load speed as shown in the table below.  
60Hz operation-----Approx. 60 GHz (1800rpm)
12. Adjust the Voltage Regulator to the specified voltage.

**Manual Stopping**

1. Place the Generator Circuit Breakers in the "OFF" position.
2. Set the Engine speed switch to the "LOW" position, and allow the unit to cool for a few minutes.
3. Turn the Auto-Off/Reset-Manual switch, to the "Off/Reset" position.

**Auto Starting/Stopping**

1. With the Auto/Manual switch in the Auto position, the Auto Starting/Stopping controller monitors remote start contacts. Closure of the remote start contacts will begin engine cranking. When the contacts are opened cranking will stop or if running the engine will stop. All functions for the Automatic shutdown System work as in Manual Starting/stopping.
2. For cold weather conditions utilize the water heater until water is warm. If the engine still does not start, please operate as in Manual Starting.

**Emergency Stopping**

1. Place the Generator Circuit Breakers in the "OFF" position.
2. Turn the Auto-Off/Reset-Manual switch to the "Off/Reset" position.

M35200010

P/N M3552000103

**SAFETY INSTRUCTIONS**

Improper operation of this machine can cause severe injury or death.

- Read the instruction manual carefully before operating or servicing.

This machine should only be operated by a person with sufficient knowledge and skill to ensure safe operation.

High voltage circuits are located inside the output terminal cover and control panel.

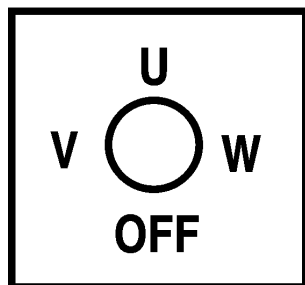
- Close the cover and control panel before operating.

Moving parts and hot surfaces are contained within the enclosure.

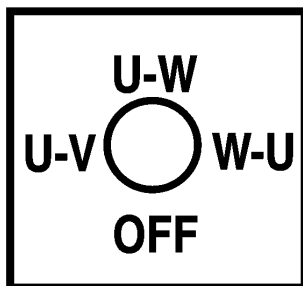
- Close all doors and lock them before operating.

M92010030

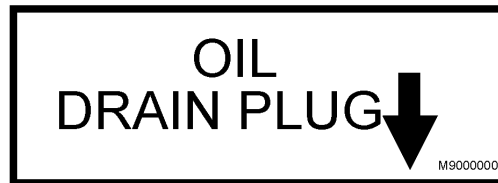
P/N M9520100304



P/N M9520000104



P/N M9520000204

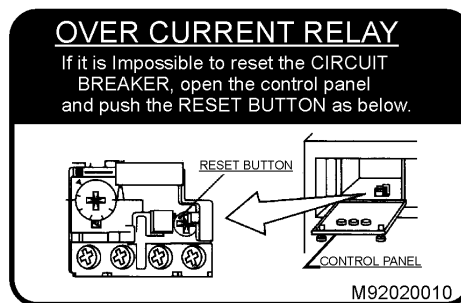


P/N M950000004

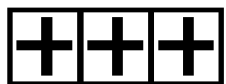


P/N M9510200002

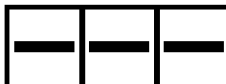
**DIESEL FUEL**  
M90050000  
P/N M9500500004



P/N M9520200104



P/N M9500300104



P/N M9500300004




P/N M9500500104

**WATER • OIL CHECK AND FILL DAILY**  
M90300010

P/N M9503000103

# DCA-125SSJU — OPERATION AND SAFETY DECALS



**⚠ WARNING**  
**ELECTRIC SHOCK HAZARD**

- Do not touch internal wiring or connections while this machine is operating.
- Turn power off before servicing.

M92010000

P/N M9520100004

**⚠ CAUTION**

Ensure the "AUTO-OFF/RESET-MANUAL" switch is in the "OFF/RESET" position. If it is not, when the battery cables are connected, the engine will crank and attempt to start.

C90530000


P/N M9505300004

**NOTE**

To use 50 AMP receptacles, adjust the voltage selector switch to the single phase position and the main line circuit breaker to the on position.

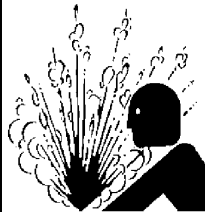
M1500020

P/N M1550000204

	<p><b>⚠ WARNING</b>  <b>ELECTRIC SHOCK HAZARD</b></p> <ul style="list-style-type: none"> <li>Do not touch output terminals while this machine is operating.</li> <li>Turn power off before servicing.</li> </ul>	<p><b>⚠ WARNING</b>  <b>ELECTRIC SHOCK HAZARD</b></p> <ul style="list-style-type: none"> <li>Always complete the grounding path from the ground terminal on this genset to an external grounding source. See instruction manual for details.</li> </ul>	<p><b>⚠ WARNING</b></p> <ul style="list-style-type: none"> <li>Before connecting this generator to any building's electrical system, a licensed electrician must install an isolation (transfer) switch.</li> <li>Serious injury or death may result without this transfer switch.</li> </ul>
---	--	---	---

M92010050

P/N M9520100503



**⚠ WARNING**  
**HOT COOLANT can cause severe burns.**

- Do not remove cap if radiator is hot.

M90310000

P/N M9503100004



**⚠ WARNING**  
**ENGINE EXHAUST can cause severe injury or death.**

- Use only in open, well ventilated areas or vent exhaust outside.


M90320000

P/N M9503200004

**⚠ CAUTION**  
**Stop engine before switching.**

M92010020

P/N M9520100204




**⚠ CAUTION**  
**MOVING PARTS can cause severe injury.**

- Do not operate with doors open.
- Stop engine before servicing.

M90300000

P/N M9503000004




**⚠ WARNING**  
**HOT PARTS can burn skin.**

- Do not touch until the machine has sufficiently cooled.

M91010000

P/N M9510100004



**⚠ WARNING**  
**ELECTRIC SHOCK HAZARD**

- Do not touch internal wiring or connections while this machine is operating.
- Turn power off before servicing.

M92010000

P/N M9520100004

# DCA-125SSJU —SPECIFICATIONS

Table 7. Specifications		
Generator Specifications		
Model	DCA-125SSJU	
Type	Revolving field, self ventilated, drip proof single bearing	
Armature Connection	Star with Neutral/ Zig Zag	
Voltage-3 phase	208, 220, 240, 416, 440, 480V switchable	
Voltage-single phase	120, 127, 139, 240, 254, 277V switchable	
Standby Output	137.5 KVA (110 KW)	
Prime Output	125 KVA (100 KW)	
Frequency	60 Hz	
Speed	1800 rpm	
Power Factor	0.8	
Sound Level dB(A) Full Load at 23 feet	67	
Insulation	Class F	
Engine Specifications		
Model	JOHN DEERE 6068TF250	
Type	4 Cycle, water-cooled, direct injection, turbo-charged	
No. of Cylinders	6 cylinders	
Bore x Stroke	(106 mm x 127 mm)	
Rated Output	150 HP/1800 rpm	
Displacement	410 cu. in. (6724 cc)	
Starting	Electric	
Coolant Capacity	10.3 gal. (39 liters)	
Lube Oil Capacity	4.5 gal. (17 liters)	
Fuel Consumption	7.5 gal(28.4L)/hr at <b>full load</b>	5.7 gal(21.6L)/hr at <b>3/4 load</b>
	4.0 gal(15.1L)/hr at <b>1/2 load</b>	2.3gal(8.7L)/hr at <b>1/4 load</b>
Battery	12V- 150 AH x1	
Fuel	#2 Diesel Fuel	

## DCA-125SSJU FAMILIARIZATION

### Generator

The MQ Power Model DCA-125SSJU is a 100 kW **generator** that is designed as a high quality portable (requires a trailer for transport) power source for telecom sites, lighting facilities, power tools, submersible pumps and other industrial and construction machinery.

### Engine Operating Panel

The "Engine Operating Panel" is provided with the following:

- Tachometer
- Water Temperature Gauge
- Oil Pressure Gauge
- Charging Ammeter Gauge
- Engine Speed Switch
- Pre-Heat Button
- Fuel leak lamp
- Low fuel lamp
- MPEC Module
- Panel Light
- Panel Light Switch

### Generator Control Panel

The "Generator Control Panel" is provided with the following:

- Output Voltage Adjustment Knob
- Frequency Meter (Hz)
- AC Ammeter (Amps)
- AC Voltmeter (Volts)
- AC Kilowatt meter
- Ammeter Change-Over Switch
- Voltmeter Change-Over Switch

### Output Terminal Panel

The "Output Terminal Panel" is provided with the following:

- Three 240/120V output receptacles, 50 amp
- Two 120V input receptacles, 20 amp
- 3 Load Circuit Breakers 265V @50 amps
- 2 Load GFCI Circuit Breakers 265V@ 20amps

### Control Box

The "Control Box" is provided with the following:

- Main Circuit Breaker 600 amps
- Over-Current Relay
- High Idle Adjust Trimmer

### Microprocessor Controlled Alarm System

The DCA-125SSJU generator is equipped with various alarms and LED status indicators. These alarms and status indicators are provided to add safety to the generator when operating under normal conditions. The DCA-125SSJU generator is designed to shutdown in the event of low oil, high coolant temperature, low battery and other operation conditions that may cause severe damage to the generator.

### Open Delta Excitation System

The DCA-125SSJU generator is equipped with the state of the art "**Open-Delta**" excitation system. The open delta system consist of an electrically independent winding wound among stationary windings of the AC output section.

There are four leads: A, B, C and D. During light loads, the power to the **Automatic Voltage Regulator (AVR)** is supplied from the leads parallel connections of B&C. When loads increase, the AVR switches and accepts power from leads A&D. The output of leads A&D increase proportionally with load. This of adding the voltages to each phase provides better voltage response during heavy loads.

The connections of the AVR to the AC output windings are for sensing only. No power is required from these windings.

The open-delta design provides virtually unlimited excitation current, offering maximum motor starting capabilities. The excitation does not have a "**fixed ceiling**" and responds according the demands of the required load.

## Engine

The **DCA-125SSJU** is powered by a 4 cycle, water cooled, **John Deere 6068TF diesel** engine. This engine is designed to meet every performance requirement for the generator. Reference Table 1, page 13 for engine specifications.

In keeping with MQ Power's policy of constantly improving its products, the specifications quoted herein are subject to change without prior notice.

The basic controls and indicators for the DCA-125SSJU generator are addressed on the following pages.

## Electronic Governor System

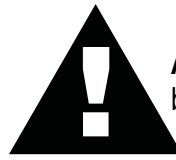
The electronic governor system replaces the standard mechanical governor system. The frequency regulation improves from  $\pm 3.0\%$  regulation with the mechanical governor to  $\pm 0.25\%$  regulation with the electronic governor system.

## Jacket Water Heater

The jacket water heater is a 1500-watt heater designed to keep the coolant warm in the engine block for fast starts and load acceptance. The heater is thermostatically controlled and once an acceptable engine temperature is achieved it will cycle on and off, operating only about 1/3 of the time, which makes it more efficient than the direct block type heater. It is designed to keep the engine coolant between 100°-120°F.

Under normal conditions, 20 to 15 minutes is required to raise the engine temperature of a cold engine to 100°F.

## CAUTION :



**ALWAYS** unplug the jacket water heater before servicing.

## Battery Charger

The battery charger will operate in a 'BOOST' mode until the battery's current acceptance falls to 70% of the charger's rating. The charger will then go into a 'FLOAT' mode, where it discharges a lower voltage until an AC failure, or the battery is discharged.

### NOTE:

The jacket water heater can be serviced if not functioning properly.

# DCA-125SSJU — WATER SEPARATOR FILTER

## Water Separator Filter

The DCA-125SSJU generator is equipped with a “Water Fuel Separator. This unit is designed to prevent dirt, rust, algae, varnishes and water from entering the fuel system.

This water separator system is designed around two filters connected in parallel (Figure 7). These two filters can be configured in a variety of ways to filter water from the fuel system.

For best results it is best to have both filters active (ON) at the same time or use only one filter, and use the other filter as a reserve, that way you can use the filters alternately every time the filter element is replaced.

## CAUTION:



DO NOT turn the control valve while the generator is in operation. This may stop fuel flow to the generator if both filters are set to the OFF position.

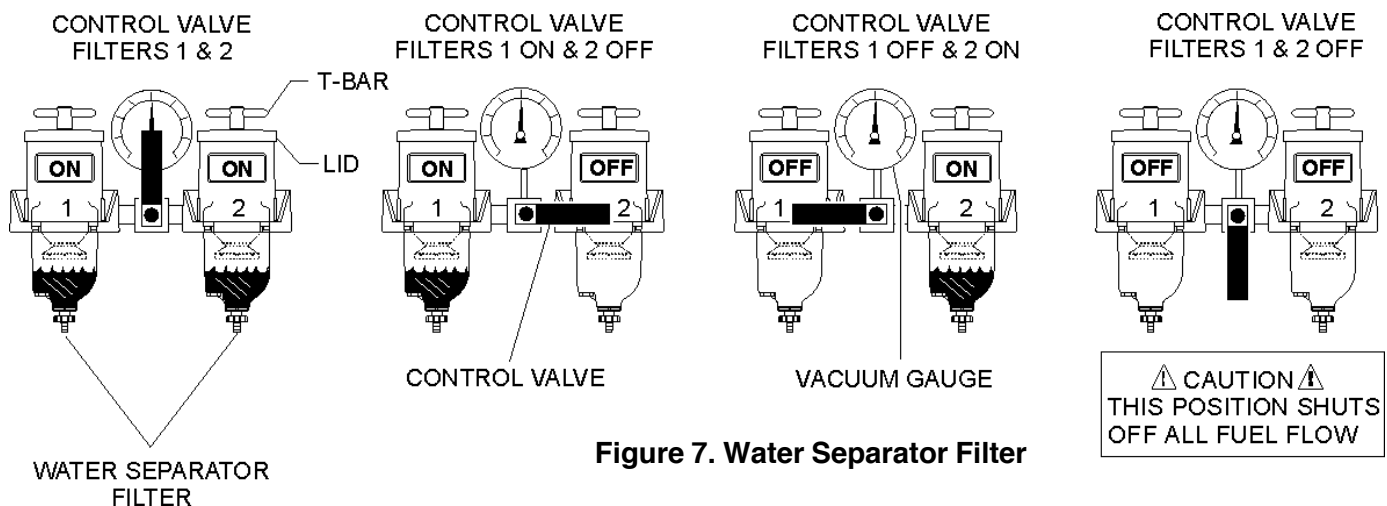


Figure 7. Water Separator Filter

## Collection Bowl Water Drainage

Inspect or drain the water in the collection bowl daily. The collection bowl must be drained before contaminants reach the bottom of the turbine.

To drain the collection bowl perform the following:

1. Open the self-venting drain to evacuate contaminants with a suitable collection container in place.
2. Prime the unit by removing the filter lid and filling with clean fuel.
3. Replace the filter lid and snugly tighten the T-handle by hand only.



# DCA-125SSJU — MAJOR COMPONENTS

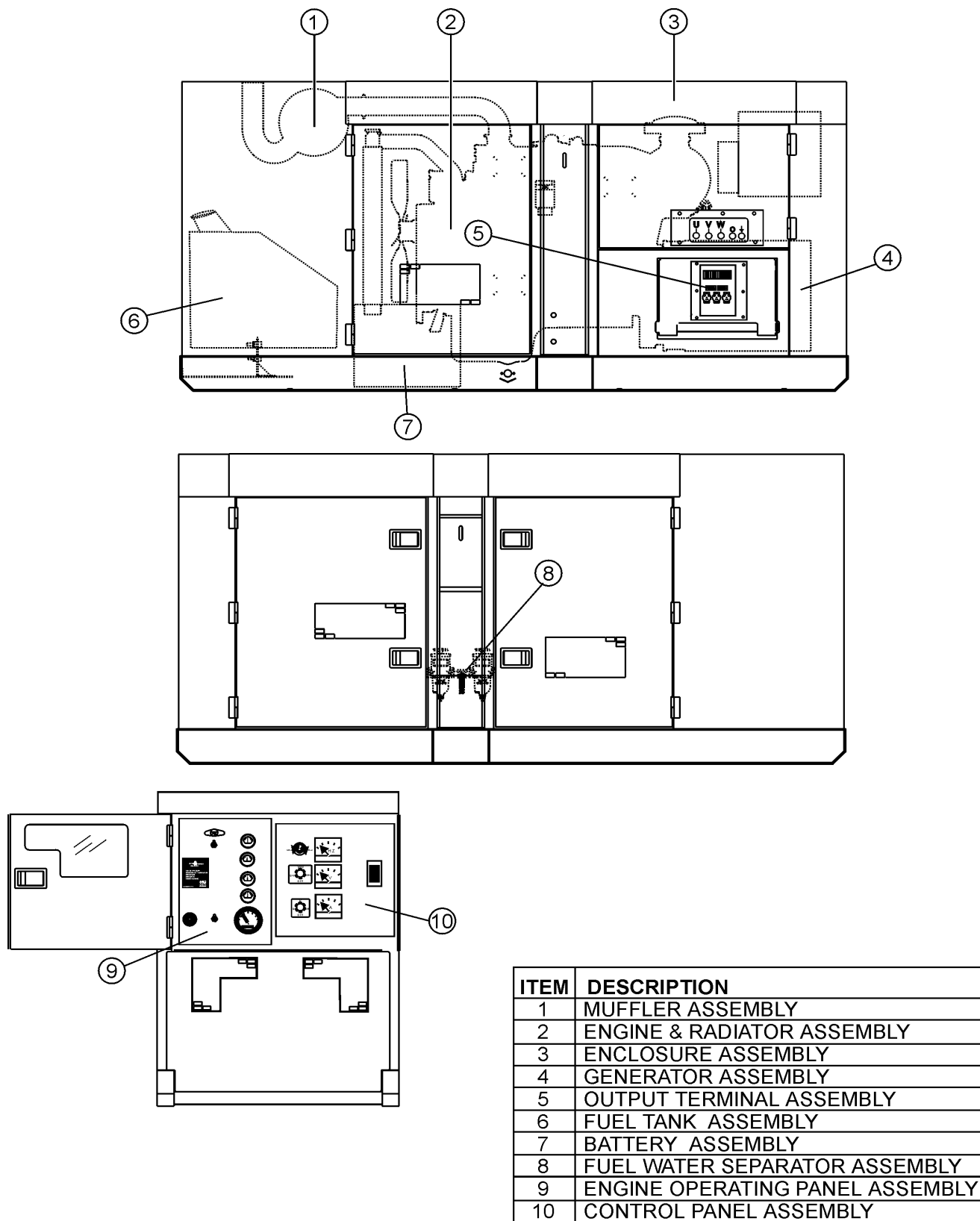
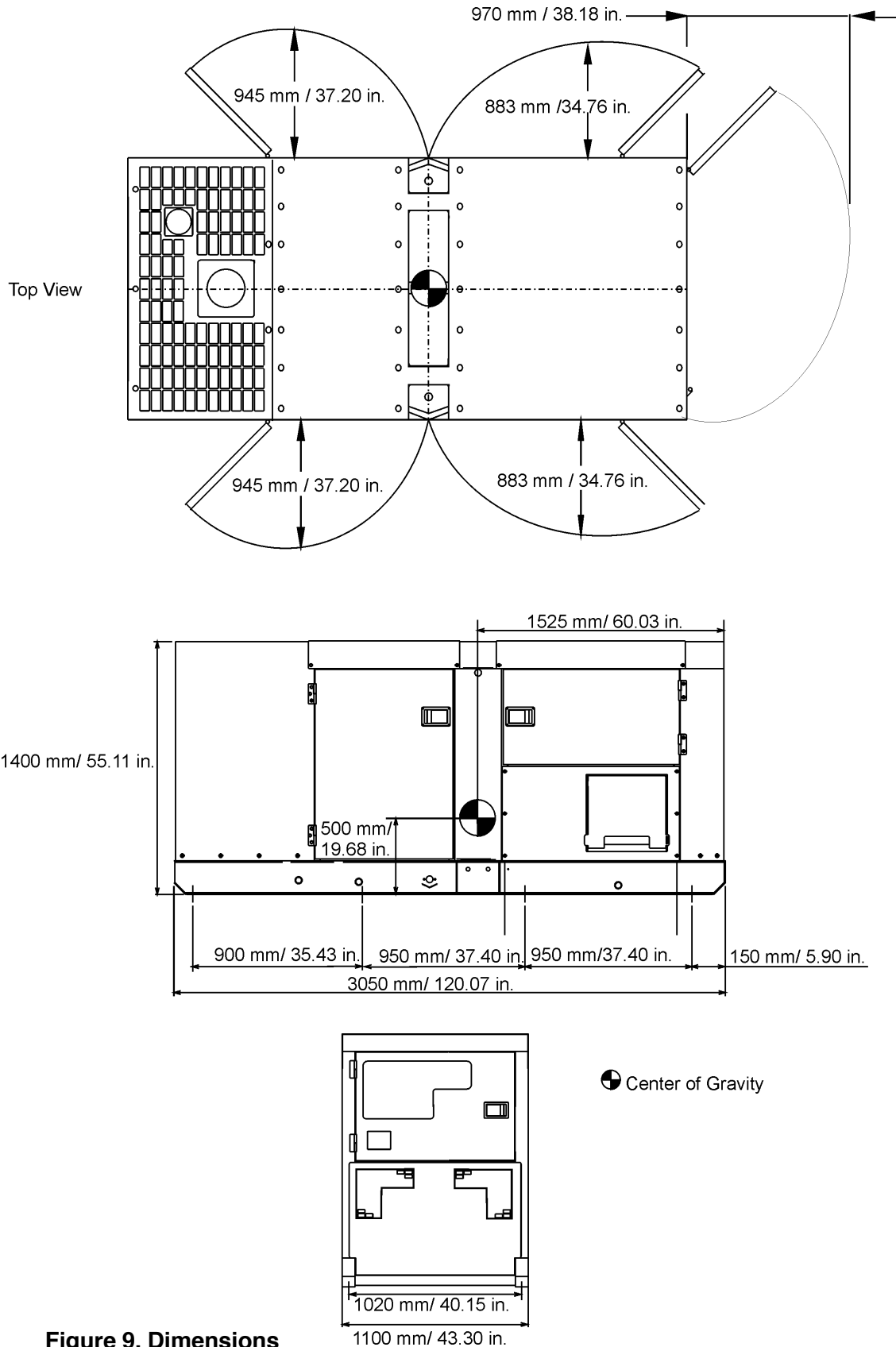
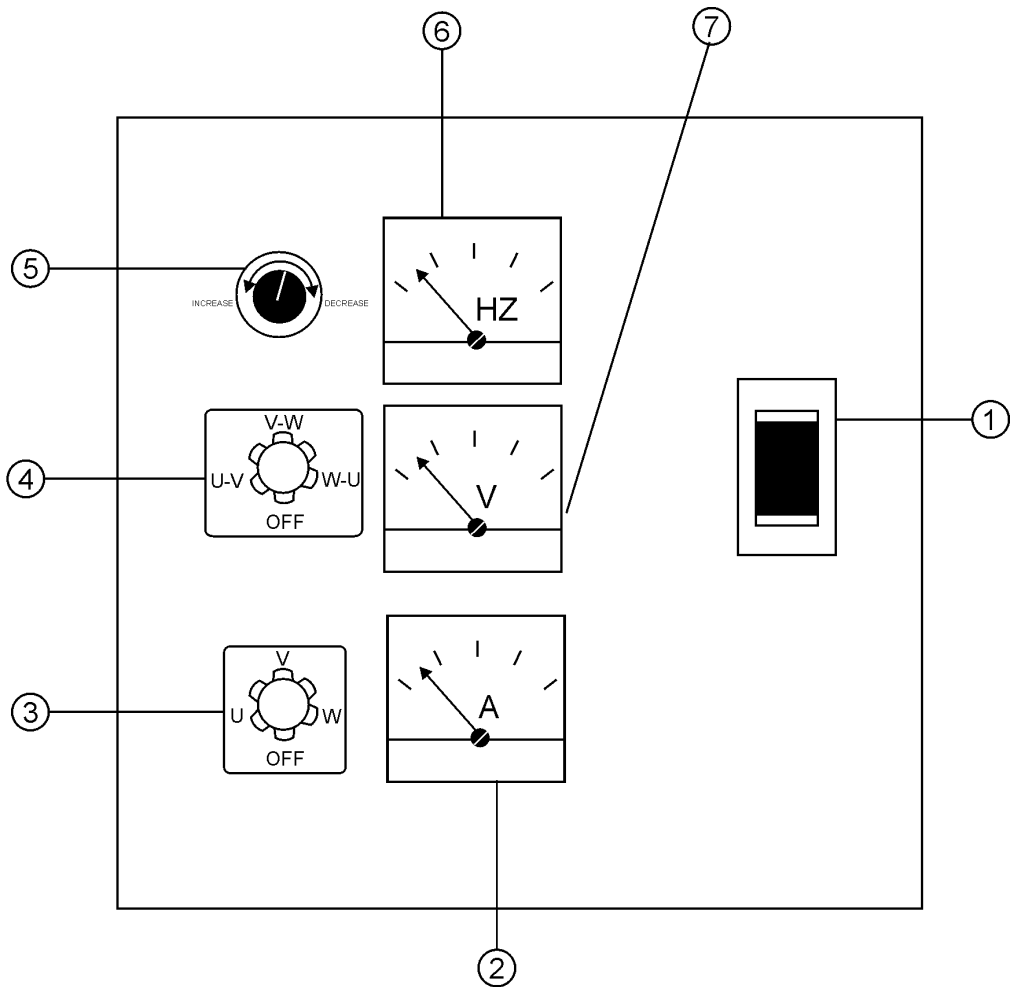


Figure 8. Major Components



**Figure 9. Dimensions**



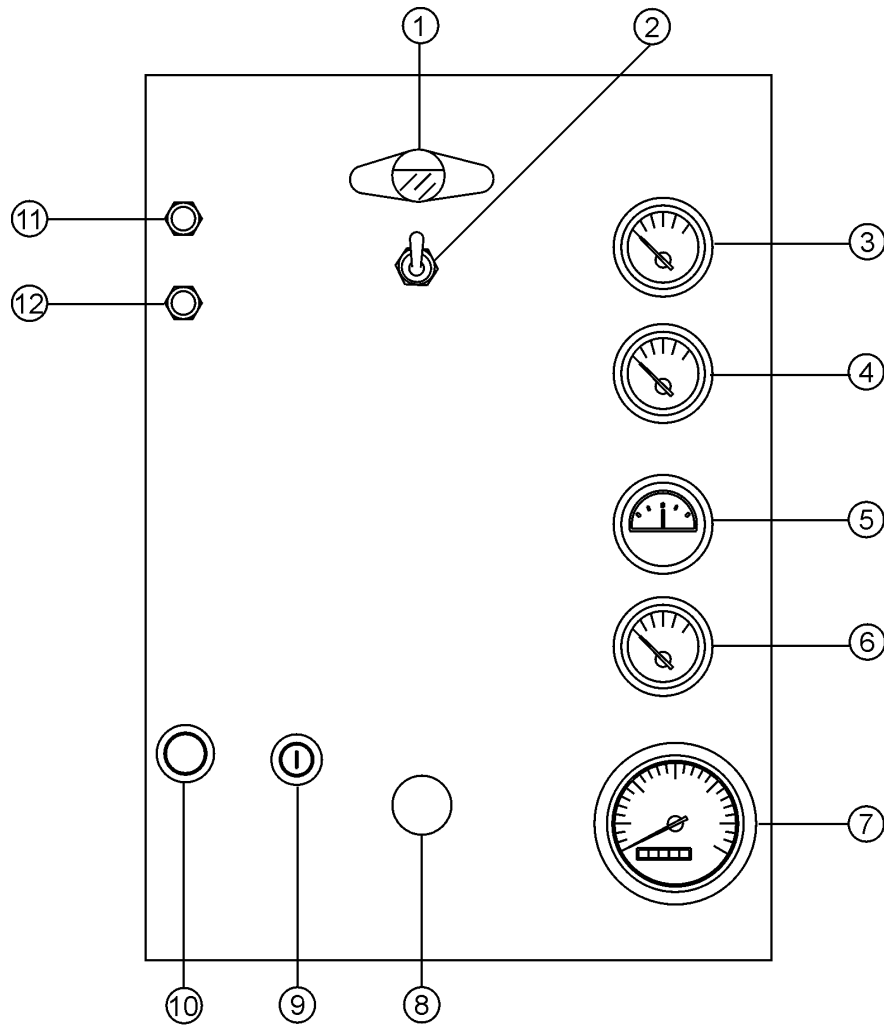
NO	DESCRIPTION
1	CIRCUIT BREAKER
2	AC AMMETER
3	AMMETER CHANGE-OVER SWITCH
4	VOLTMETER CHANGE-OVER SWITCH
5	VOLTAGE REGULATOR
6	FREQUENCY METER
7	AC VOLTMETER

Figure 10. Control Panel

The definitions below describe the controls and functions of the DCA-125SSJU " **Control Panel** " (Figure 10).

1. **Main Circuit Breaker** – This three-pole, 300 amp main breaker is provided to protect the UNV voltage output terminals from overload.
2. **AC Ammeter** – Indicates the amount of current the load is drawing from the generator.
3. **Ammeter Change-Over Switch** – This switch allows the AC ammeter to indicate the current flowing to the load connected to any phase of the output terminals, or to be switched off.
4. **Voltmeter Change-Over Switch** – This switch allows the AC voltmeter to indicate phase to phase voltage between any two phases of the output terminals or to be switched off.
5. **Voltage Regulator Control** – Allows manual adjustment of the generator's output voltage.
6. **Frequency Meter** – Indicates the output frequency in hertz (Hz). Normally 60 Hz  $\pm$ 1 Hz .
7. **ACVoltmeter** – Indicates the single phase output voltage present at the UNV terminals.

# DCA-125SSJU — ENGINE OPERATING PANEL(WITH KEY)



NO	DESCRIPTION
1	PANEL LIGHT
2	PANEL LIGHT SWITCH
3	OIL PRESSURE GAUGE
4	WATER TEMPERATURE GAUGE
5	CHARGING AMMETER
6	FUEL GAUGE
7	TACHOMETER
8	ENGINE THROTTLE LEVER
9	STARTER SWITCH
10	COLD STARTING BUTTON
11	OIL PRESSURE INDICATOR
12	WATER TEMPERATURE INDICATOR

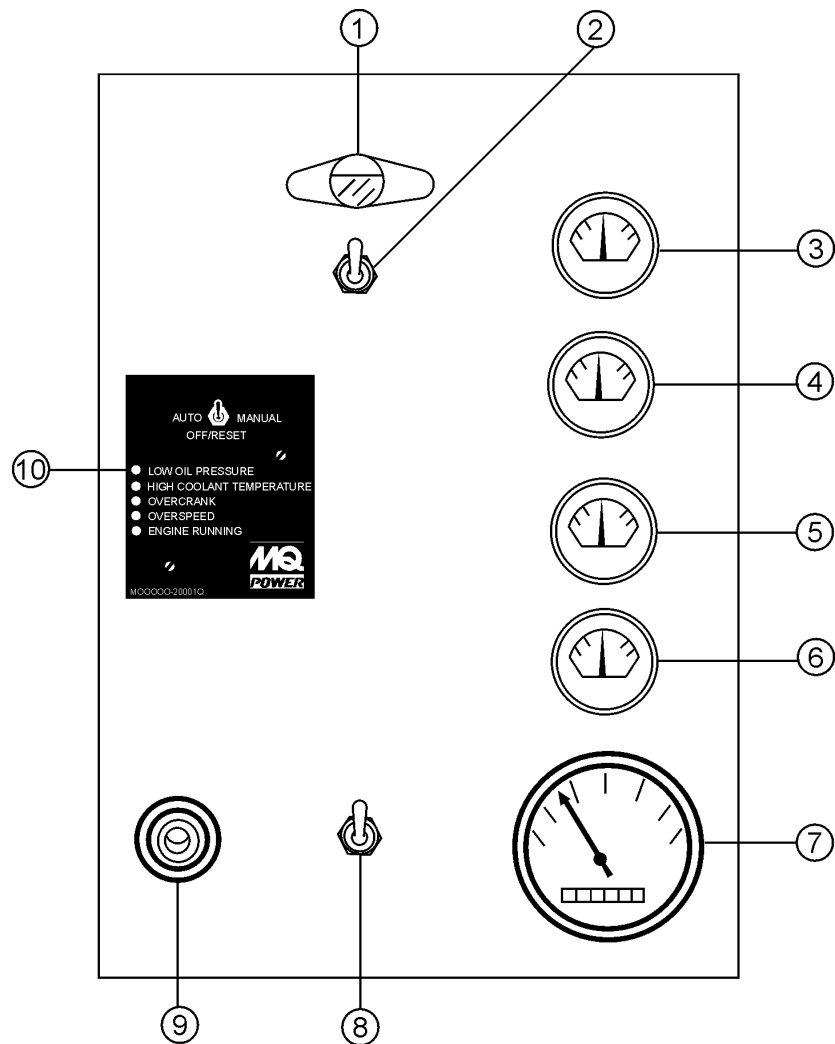
Figure 11. Engine Operating Panel

## DCA-125SSJU — ENGINE OPERATING PANEL(WITH KEY)

The definitions below describe the controls and functions of the DCA-125SSJU " **Engine Operating Panel** " (Figure 11).

1. **Panel light** - Normally used in dark places or at night. When activated, panel will luminate. When the generator is not in use, turn the panel light switch to the 'OFF' position.
2. **Panel light switch**- When activated, will turn on control panel light.
3. **Oil Pressure Gauge** – Normal operation should be about 25 psi. When starting the generator the oil pressure may read a bit higher, but after the engine warms up the oil pressure should return to normal.
4. **Water Temperature Gauge** – During normal operation this gauge should read between 165° to 215°.
5. **Charging Ammeter Gauge** – Indicates the current being supplied by the engine's alternator which provides current for generator's control circuits and battery charging system.
6. **Fuel Gauge** - Indicates amount of diesel fuel available.
7. **Tachometer** – Indicates engine speed in RPM's for 60 Hz operation. This meter should indicate 1800 RPM's when the rated load is applied. In addition a built in hour meter will record the number of operational hours that the generator has been in use.
8. **Engine Throttle Lever**- This lever will change the speed of the engine from high to low.
9. **Pre-Heat Button** – Press hold this button to start the engine in cold conditions.
10. **Starter Switch with Key** – This switch has three different positions: Stop-Turn the key to stop the engine. Start-Turn the key to this position to start the engine. Release the key once the engine has started and it will automatically return to the operating position.
11. **Oil Pressure Indicator** - This indicator lets the operator know the oil pressure is dangerously high or low and will shut down the engine.
12. **Water Temperature Indicator** - This indicator lets the operator know the water temperature is dangerously high and will shut down the engine.

# DCA-125SSJU — ENGINE OPERATING PANEL



NO	DESCRIPTION
1	PANEL LIGHT
2	PANEL LIGHT SWITCH
3	OIL PRESSURE GAUGE
4	WATER TEMPERATURE GAUGE
5	CHARGING AMMETER
6	FUEL GAUGE
7	TACHOMETER
8	ENGINE SPEED SWITCH
9	PREHEAT BUTTON
10	AUTO/START/STOP CONTROLLER

Figure 12. Engine Operating Panel

# DCA-125SSJU — ENGINE OPERATING PANEL

The definitions below describe the controls and functions of the DCA-125SSJU " *Engine Operating Panel* " (Figure 12).

1. **Panel light** - Normally used in dark places or at night. When activated, panel will luminate. When the generator is not in use, turn the panel light switch to the 'OFF' position.
2. **Panel light switch**- When activated, will turn on control panel light.
3. **Oil Pressure Gauge** – Normal operation should be about 25 psi. When starting the generator the oil pressure may read a bit higher, but after the engine warms up the oil pressure should return to normal.
4. **Water Temperature Gauge** – During normal operation this gauge be should read between 165° to 215°.
5. **Charging Ammeter Gauge** – Indicates the current being supplied by the engine's alternator which provides current for generator's control circuits and battery charging system.
6. **Fuel Gauge** - Indicates amount of diesel fuel available.
7. **Tachometer** – Indicates engine speed in RPM's for 60 Hz operation. This meter should indicate 1800 RPM's when the rated load is applied. In addition a built in hour meter will record the number of operational hours that the generator has been in use.
8. **Engine speed Handle**- This handle will change the speed of the engine from high to low.

9. **Pre-Heat Button** – Press hold this button until the pre-heat lamp is lit (ON).



10. **MPEC – Microprocessor Engine Control Module** – (MPEC) has a vertical row of status LED's (Figure 13), that when lit, indicate that an engine malfunction (fault), has been detected. When a fault has

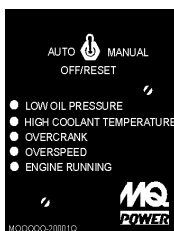


Figure 13. MPEC

been detected the MPEC will evaluate the fault and all major faults will shutdown the generator. During **cranking cycle**, The MPEC will attempt to crank the engine for 10 seconds before disengaging. If the engine does not engage (start) by the third attempt, the engine will be shut-down by the MPEC's " Over Crank Protection" mode. If the engine engages at a speed (RPM's) that is not safe, the MPEC will shut-down the engine by initializing the "Over Speed Protection" mode.

Also the MPEC will shut-down the generator in the event of low oil pressure, high coolant temperature, low coolant level, and loss of magnetic pickup. These conditions can be observed by monitoring the LED status indicators on the front of the MPEC module.

- A. **Off/Manual/Auto Switch** – This switch controls the running of the generator. If this switch is left in the "OFF" position, the generator will not run. When this switch is set to the **manual** position, the generator will start immediately.

If the generator is to be connected to a building's AC power source via a transfer switch (isolation), place the switch in the **auto** position. In this position the generator will monitor the AC line output from the building's power source.

- B. **Low Oil Pressure** – Indicates the engine pressure has fallen below 15 psi. The oil pressure is detected using variable resistive values from the oil pressure sending unit. This is considered a **major** fault.
- C. **High Coolant Temperature** – Indicates the engine temperature has exceeded 215°F. The engine temperature is detected using variable resistive values from the temperature sending unit. This is considered a **major** fault.
- D. **Overcrank Shutdown** – Indicates the unit has attempted to start a pre-programmed number of times, and has failed to start. The number of cycles and duration are programmable. It is pre-set at 3 cycles with a 10 second duration. This is considered a **major** fault.
- E. **Overspeed Shutdown** – Indicates the engine is running at an unsafe speed. This is considered a **major** fault.
- F. **Engine Running** – Indicates that engine is running at a safe operating speed.

# DCA-125SSJU — OUTPUT TERMINAL PANEL

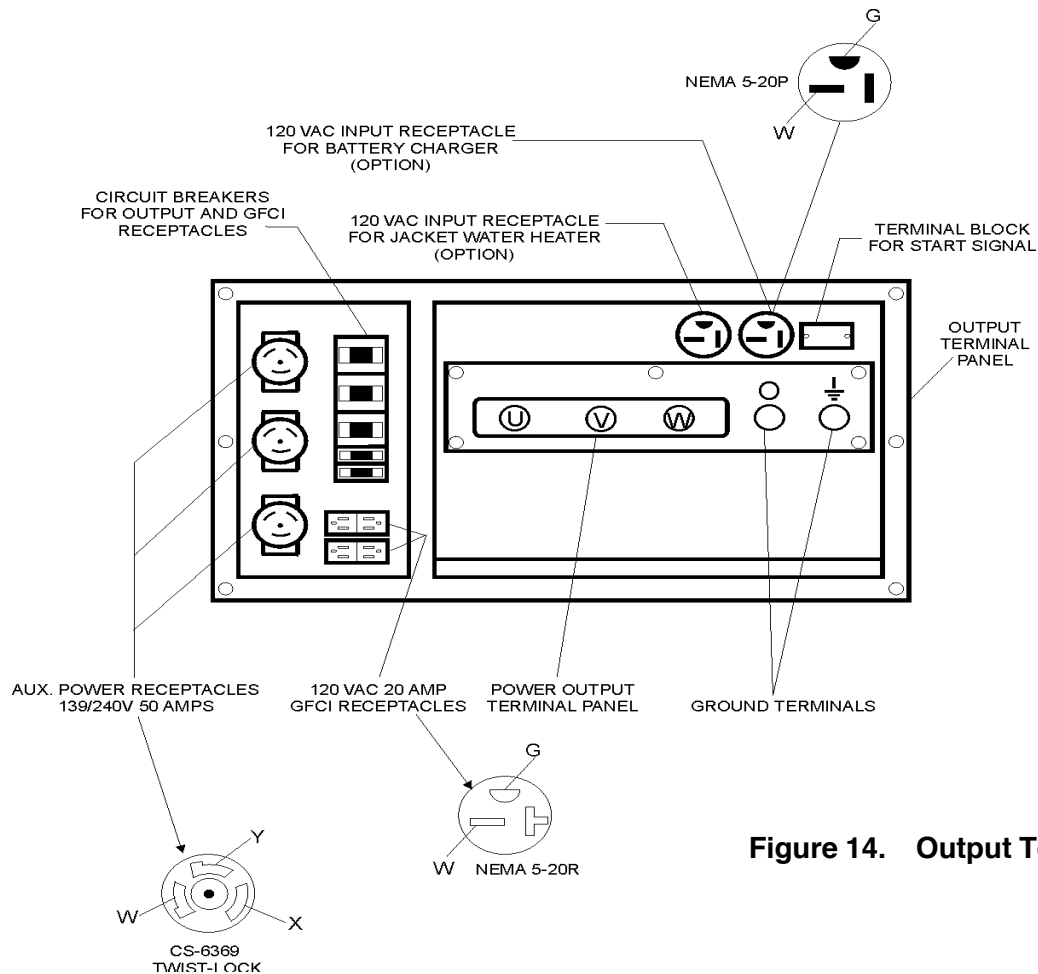


Figure 14. Output Terminal Panel

**120V Receptacles** - These receptacles can be used anytime the generator is in operation. They are controlled by the circuit breakers above them.

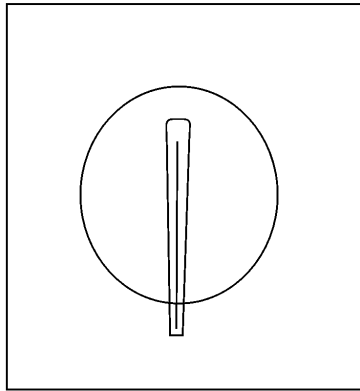
**Twist Lock Dual Voltage Receptacles** - To use these receptacles, place the voltage selector switch in the single phase 240/120 voltage position and adjust the output voltage to 240 volts with the voltage regulator on the Control Panel (see figure 10). Place the voltmeter change-over switch to the U-W position and the ammeter change-over switch to the U or W to read the output.

Table 8. Receptacle Use

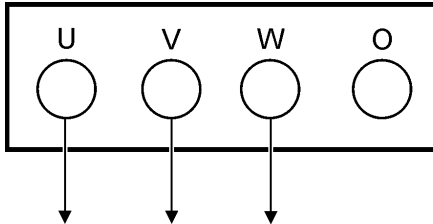
Power in Use		Receptacle Power Available
240/480V 3-Phase	240/120V Single Phase or Twist Lock CS6369	Duplex NEMA 5-20R 120V
125	72	0
121	70.8	1.2
117	69.6	2.4
113	68.4	3.6
108	67.2	4.8

# DCA-125SSJU — OUTPUT TERMINAL VOLTAGE SELECTION

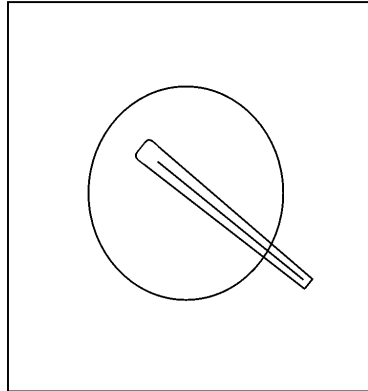
VOLTAGE SELECTOR SWITCH, 3 PHASE  
240V/139V



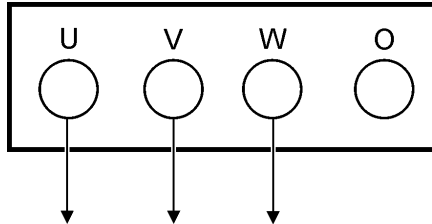
OUTPUT TERMINALS  
3-PHASE, 240V, 220V, 208V



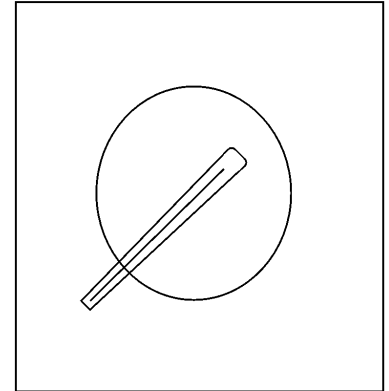
VOLTAGE SELECTOR SWITCH, 3 PHASE  
480V/277V



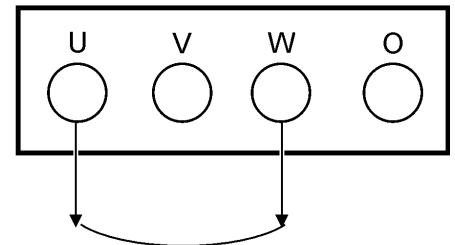
OUTPUT TERMINALS  
3-PHASE, 480V, 440V, 416V



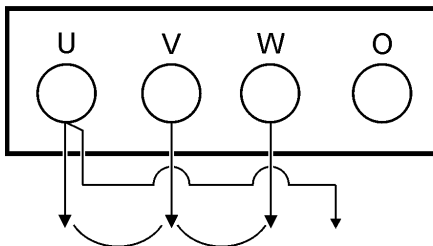
VOLTAGE SELECTOR SWITCH, SINGLE PHASE  
240V/120V



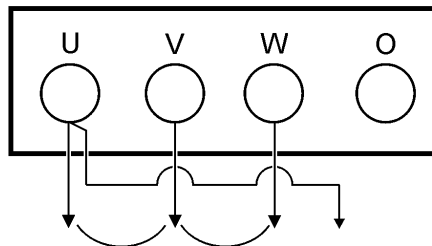
OUTPUT TERMINALS  
SINGLE PHASE, 240V



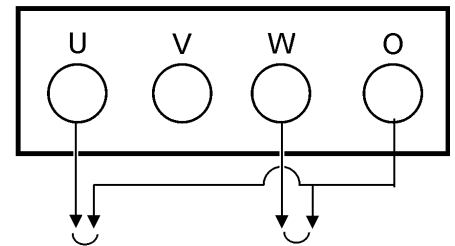
OUTPUT TERMINALS  
2-PHASE, 240V, 220V, 208V



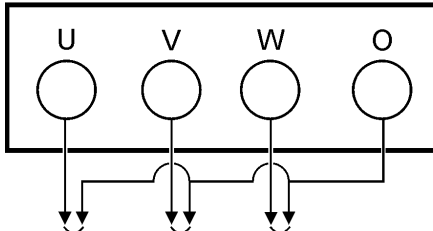
OUTPUT TERMINALS  
2-PHASE, 480V, 440V, 416V



OUTPUT TERMINALS  
SINGLE PHASE, 120V



OUTPUT TERMINALS  
SINGLE PHASE, 139V, 127V, 120V



OUTPUT TERMINALS  
SINGLE PHASE, 277V, 254V, 240V

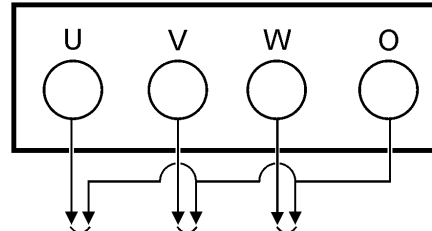


Figure 15. Output Terminal Voltage Selection

## Outdoor Installation

Install the generator in a location where it will not be exposed to rain or sunshine. Make sure the generator is on secure level ground so it cannot slide or shift around. Also install the generator so the exhaust will not be discharged in the direction of nearby homes.

The installation site must be relatively free from moisture and dust. All electrical equipment should be protected from excessive moisture. Failure to do will result in deterioration of the insulation and will result in short circuits and grounding.

Foreign materials such as dust, sand, lint and abrasive materials have a tendency to cause excessive wear to the engine parts and alternator.

## CAUTION :



Pay close attention to ventilation when operating the generator inside tunnels and caves. The engine exhaust contains noxious elements. Engine exhaust must be routed to a ventilated area.

## Indoor Installation

Exhaust gases from diesel engines are extremely poisonous. Whenever an engine is installed indoors the exhaust fumes must be vented to the outside. The engine should be installed at least two feet from any outside wall. Using an exhaust pipe which is too long or too small can cause excessive back pressure which will cause the engine to heat excessively and possibly burn the valves.

## CAUTION :



An electric shock may happen when vibrators are used. Pay close attention to handling when operating vibrators and always use rubber boots and gloves to insulate the body from electrical shock.

## Generator Grounding

To guard against electrical shock and possible damage to the equipment, it is important to provide a good **EARTH** ground.

Article 250 (Grounding) of the National Electrical Code (NEC) provides guide lines for proper grounding and specifies that the cable ground shall be connected to the grounding system of the building as close to the point of cable entry as practical.

NEC articles 250-64(b) and 250-66 set the following grounding requirements:

1. Use one of the following wire types to connect the generator to earth ground.
  - a. Copper - 10 AWG (5.3 mm<sup>2</sup>) or larger.
  - b. Aluminum - 8 AWG (8.4 mm<sup>2</sup>) or larger.
2. When grounding the generator (Figure 16) connect the ground cable between the lock washer and the nut on the generator and tighten the nut fully. Connect the other end of the ground cable to earth ground.
3. NEC article 250-52(c) specifies that the earth ground rod should be buried a minimum of 8 ft. into the ground.

## NOTE

When connecting the generator to any buildings electrical system **ALWAYS** consult with a licensed electrician.

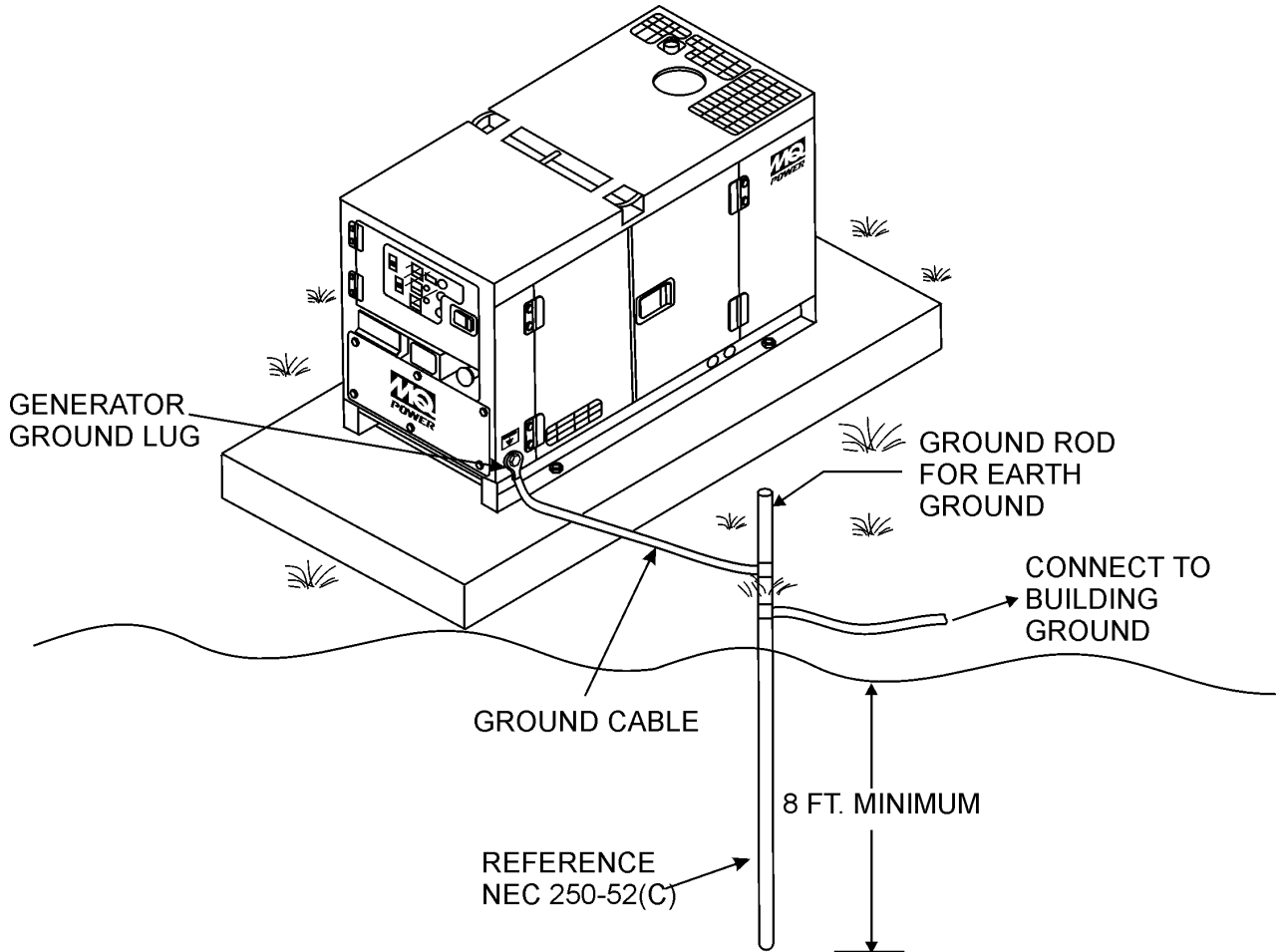


Figure 16. Typical Generator Grounding Application

## General Inspection Prior to Operation

The DCA-125SSJU generator has been thoroughly inspected and accepted prior to shipment from the factory. However, be sure to check for damaged parts or components, or loose nuts and bolts, which could have occurred in transit.

## Extension Cable

When electric power is to be provided to various tools or loads at some distance from the generator, extension cords are normally used. Cables should be sized to allow for distance in length and amperage so that the voltage drop between the generator and point of use (load) is held to a minimum. Use the Cable Selection Guide (Table 9) as a guide for selecting proper cable size.

## Circuit Breakers

To protect the generator from an overload, a 3-pole, 600 amp, **main** circuit breaker is provided to protect the UNV output terminals from overload. In addition two single-pole, 20 amp **GFCI** circuit breakers are provided to protect the GFCI receptacles from overload. Three 50 amp **load** circuit breakers have also been provided to protect the load side of the generator from overload. Make sure to switch **ALL** circuit breakers to the "OFF" position prior to starting the engine.

### NOTE

**ALWAYS** consult with a licensed electrician for correct extension cord wire size.

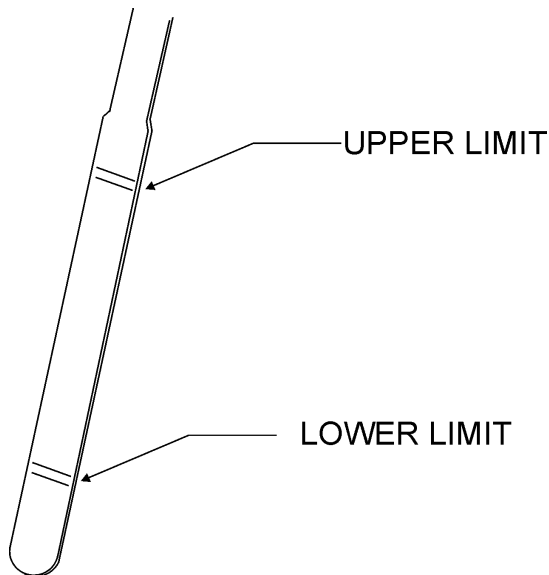
**Table 9. Cable Selection (60 Hz, Single Phase Operation)**

Current in Amperes	Load In Watts		Maximum Allowable Cable Length			
	At 120 Volts	At 240 Volts	#10 Wire	#12 Wire	#14 Wire	#16 Wire
2.5	300	600	1000 ft.	600 ft.	375 ft.	250 ft.
5	600	1200	500 ft.	300 ft.	200 ft.	125 ft.
7.5	900	1800	350 ft.	200 ft.	125 ft.	100 ft.
10	1200	2400	250 ft.	150 ft.	100 ft.	
15	1800	3600	150 ft.	100 ft.	65 ft.	
20	2400	4800	125 ft.	75 ft.	50 ft.	

**CAUTION:** Equipment damage can result from low voltage.

## Lubrication Oil

Fill the engine crankcase with lubricating oil through the filler hole, but do not overfill. Make sure the generator is level. With the dipstick inserted all the way, but without being screw into the filler hole, verify the oil level is maintained between the two notches (Figure 17) on the dipstick. See Table 10 for proper selection of engine oil.



**Figure 17. Engine Oil Dipstick**

When checking the engine oil, be sure to check if the oil is clean and viscous. If the oil is not clean, drain the oil by removing the oil drain plug, and refill with the specified amount of oil as outlined in the **John Deere Engine Owner's Manual**.

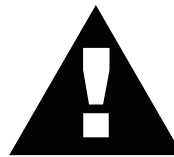
## Fuel

Fill the fuel tank with clean and fresh **diesel fuel**. **DO NOT** fill the tank beyond capacity.

Pay attention to the fuel tank capacity when replenishing fuel. Refer to the fuel tank capacity listed on page 23, Specification Table 7.

The fuel tank cap must be closed tightly after filling. Handle fuel in a safety container. If the container does not have a spout, use a funnel. Wipe up any spilled fuel immediately.

## CAUTION:



Never fill the fuel tank while the engine is running or in the dark. Diesel spillage on a hot engine can cause a fire or explosion. If diesel spillage occurs, wipe up the spilled diesel completely to prevent fire hazards.

## Coolant

Use only drinkable tap water. If hard water or water with many impurities is used, the inside of the engine and radiator may become coated with deposits and cooling efficiency will be reduced.

An anticorrosion additive added to the water will help prevent deposits and corrosion in the cooling system. See the engine manual for further details.

**Table 10. Recommended Motor Oil**

Temperature Range	Type Oil
104° F ~ 23° F (40° C ~ -5° C)	SAE 15W-40
23° F ~ 5° F (-5° C ~ -15° C)	SAE 5W-30
Below 5° C (-15°)	SAE 30 OR SAE 0W-30

## CAUTION :



When adding coolant or antifreeze to the radiator, do not remove the radiator cap until the unit has completely cooled.

Day-to-day addition of coolant is done from the reserve tank. When adding coolant to the radiator, **DO NOT** remove the radiator cap until the unit has completely cooled. See Table 11 for engine, radiator, and reserve tank coolant capacities. Make sure the coolant level in the reserve tank is always between the "H" and the "L" markings.

Table 11. Coolant Capacity

Engine and Radiator	6.1 Gal. (23 Liters)
Reserve Tank	2 Quarts (1.9 Liters)

### Operation in Freezing Weather

When operating in freezing weather, be certain the proper amount of antifreeze (Table 12) has been added.

Table 12. Anti-Freeze Operating Temperatures

Vol % Anti-Freeze	Freezing Point		Boiling Point	
	°C	°F	°C	°F
40	-24	-12	106	222
50	-37	-34	108	226

#### NOTE

*When the anti-freeze is mixed with water, the anti-freeze mixing ratio must be less than 50%.*

### Cleaning the Radiator

The engine may overheat if the radiator fins become overloaded with dust or debris. Periodically clean the radiator fins with compressed air. Cleaning inside the machine is dangerous, so clean only with the engine turned off and the battery disconnected.

### Air Cleaner

Periodic cleaning/replacement is necessary. Inspect it in accordance with the **John Deere Engine Owner's Manual**.

### Fan Belt Tension

A slack fan belt may contribute to overheating, or to insufficient charging of the battery. Inspect the fan belt for damage and wear and adjust it in accordance with the **John Deere Engine Owner's Manual**.

The fan belt tension is proper if the fan belt bends 7 to 10 mm (Figure 18) when depressed with the thumb as shown below.

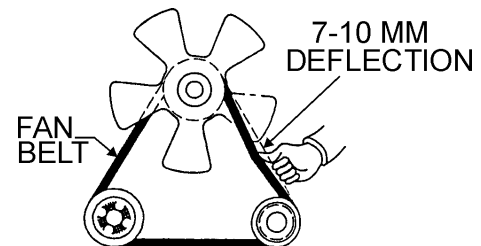


Figure 18. Fan Belt Tension

## CAUTION :



Never place hands near the belts or fan while the generator set is running.

### Battery

This unit is of negative ground. **DO NOT** connect in reverse. Always maintain battery fluid level between the specified marks. Battery life will be shortened, if the fluid level is not properly maintained. Add only distilled water when replenishment is necessary.

The battery is sufficiently charged if the specific gravity of the battery fluid is 1.28 (at 68° F). If the specific gravity should fall to 1.245 or lower, it indicates that the battery is dead and needs to be recharged or replaced.

Check to see whether the battery cables are loose. Poor contact may result in poor starting or malfunctions. Always keep the terminals firmly tightened. Coating the terminals with a thin film of grease will help to inhibit corrosion.

## Battery Cable Installation

**ALWAYS** be sure the battery cables (Figure 19) are properly connected to the battery terminals as shown below. The **RED** cable is connected to the positive terminal of the battery, and the **BLACK** cable is connected to the negative terminal of the battery.

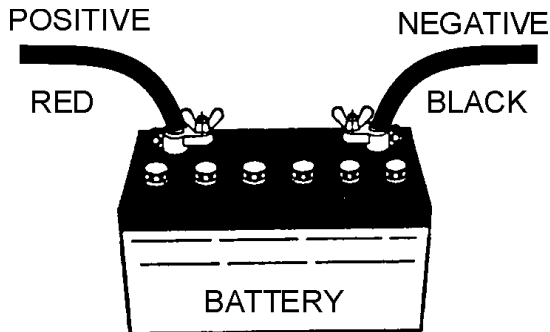
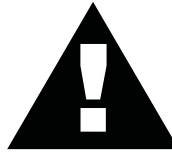


Figure 19. Battery Connections

## CAUTION :



Inadequate battery connections may cause poor starting of the generator, and create other malfunctions.

### Wiring

Inspect the entire generator for bad or worn electrical wiring or connections. If any wiring or connections are exposed (insulation missing) replace wiring immediately.

### Piping and Hose Connection

Inspect all piping, oil hose, and fuel hose connections for wear and tightness. Tighten all hose clamps and check hoses for leaks.

If any hose (fuel or oil) lines are defective replace them immediately.

## CAUTION :



If the battery cable is connected incorrectly, electrical damage to the generator will occur. Pay close attention to the polarity of the battery when connecting the battery.

When connecting battery do the following:

1. **DO NOT** connect the battery cables to the battery terminals when the **Off/Manual/Auto** switch is in either the manual or auto position (ON). **ALWAYS** make sure that the Off/Manual/Auto switch is in the OFF position when connecting the battery..
2. Place a small amount of grease around both battery terminals. This will ensure a good connection and will help prevent corrosion around the battery terminals.

## Single Phase Load

Always be sure to check the nameplate on the generator and equipment to insure the wattage, amperage and frequency requirements are satisfactorily supplied by the generator for operating the equipment.

Generally, the wattage listed on the nameplate of the equipment is its rated output. Equipment may require 130—150% more wattage than the rating on the nameplate, as the wattage is influenced by the efficiency, power factor and starting system of the equipment.

### NOTE

If wattage is not given on the equipment's name plate, approximate wattage may be determined by multiplying nameplate voltage by the nameplate amperage.

$$\text{WATTS} = \text{VOLTAGE} \times \text{AMPERAGE}$$

The power factor of this generator is 1.0. See Table 13 below when connecting loads.

Table 13. Power Factor By Load

Type Of Load	Power Factor
Single-phase induction motors	0.4 - 0.75
Electric heaters, incandescent lamps	1.0
Fluorescent lamps, mercury lamps	0.4 - 0.9
Electronic devices, communication equipment	1.0

## Three Phase Load

When calculating the power requirements for 3-phase power use the following equation:

$$\text{KVA} = \frac{\text{VOLTAGE} \times \text{AMPERAGE} \times \sqrt{3}}{1000}$$

## CAUTION:



Motors and motor-driven equipment draw much greater current for starting than during operation.

An inadequate size connecting cable which cannot carry the required load can cause a voltage drop which can burn out the appliance or tool and overheat the cable.

- When connecting a resistance load such as an incandescent lamp or electric heater, a capacity of up to the generating set's rated output (kW) can be used.
- When connecting a fluorescent or mercury lamp, a capacity of up to the generating set's rated output (kW) multiplied by 0.6 can be used.
- When connecting an electric drill or other power tools, pay close attention to the required starting current capacity.

When connecting ordinary power tools, a capacity of up to the generating set's rated output (kW) multiplied by 0.8 can be used.

## CAUTION:



Before connecting this generator to any building's electrical system, a licensed electrician must install an isolation (transfer) switch. Serious injury or death may result without this transfer switch.

### NOTE

If output (kVA) is not given on the equipment nameplate, approximate output may be determined by multiplying voltage by amperage by  $\sqrt{3}$ .

## WARNING:



The engine's exhaust contains harmful emissions. **ALWAYS** ventilate the exhaust when operating inside tunnels, excavations or buildings. Direct exhaust away from nearby personnel.

### Before Starting Engine

1. Check the lubricating oil level prior to starting the engine. Make sure the generator is level. The oil level must be maintained between two notches on the dipstick.
2. When there is not enough lubricating oil, fill the crankcase with high grade motor oil. Use a high quality detergent oil classified CC or higher (See Table 10 on page 39).
3. Check the coolant level in the radiator and subtank. Replenish with antifreeze as necessary. Always maintain the coolant level between the **FULL** and **LOW** markings on the coolant container. Be sure that the radiator cap is fastened securely.
4. Check the fuel level on the fuel gauge. If fuel is low, fill the fuel tank with clean fresh unleaded automotive diesel. If diesel spillage occurs, completely wipe up the spilled fuel immediately.

### Before Starting

#### Generator and Control Panel

## CAUTION:



**NEVER** start the engine with the *main*, *GFCI* or *load* circuit breakers in the **ON** position.

1. Be sure to disconnect the electrical load and switch the *main*, *load* and *G.F.C.I.* circuit breakers (Figure 20) to the "OFF" position prior to starting the engine.

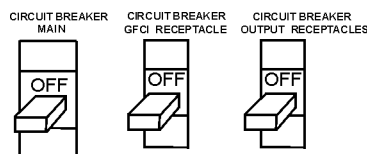


Figure 20. Main, GFCI and Load Circuit Breakers

### Jacket Water Heater and Internal Battery Charger 120 VAC Output Receptacles

This generator is equipped with two 120 VAC, 20 amp output receptacles located on the output terminal panel, page 34, Figure 13.

The purpose of these receptacles is to provide power via commercial power to the jacket water heater and internal battery charger.

These receptacles will **ONLY** function when commercial power has been supplied to them (Figure 21). To apply commercial power to these receptacles, a power cord of adequate size will be required.

When using the generator in **hot** climates there is no reason to apply power to jacket water heater. However, if the generator will be used in **cold** climates it is always a good idea to apply power to the jacket water heater at all times. To apply power to the jacket water heater simply apply power to the jacket water heater receptacle via commercial power using an power cord of adequate size.

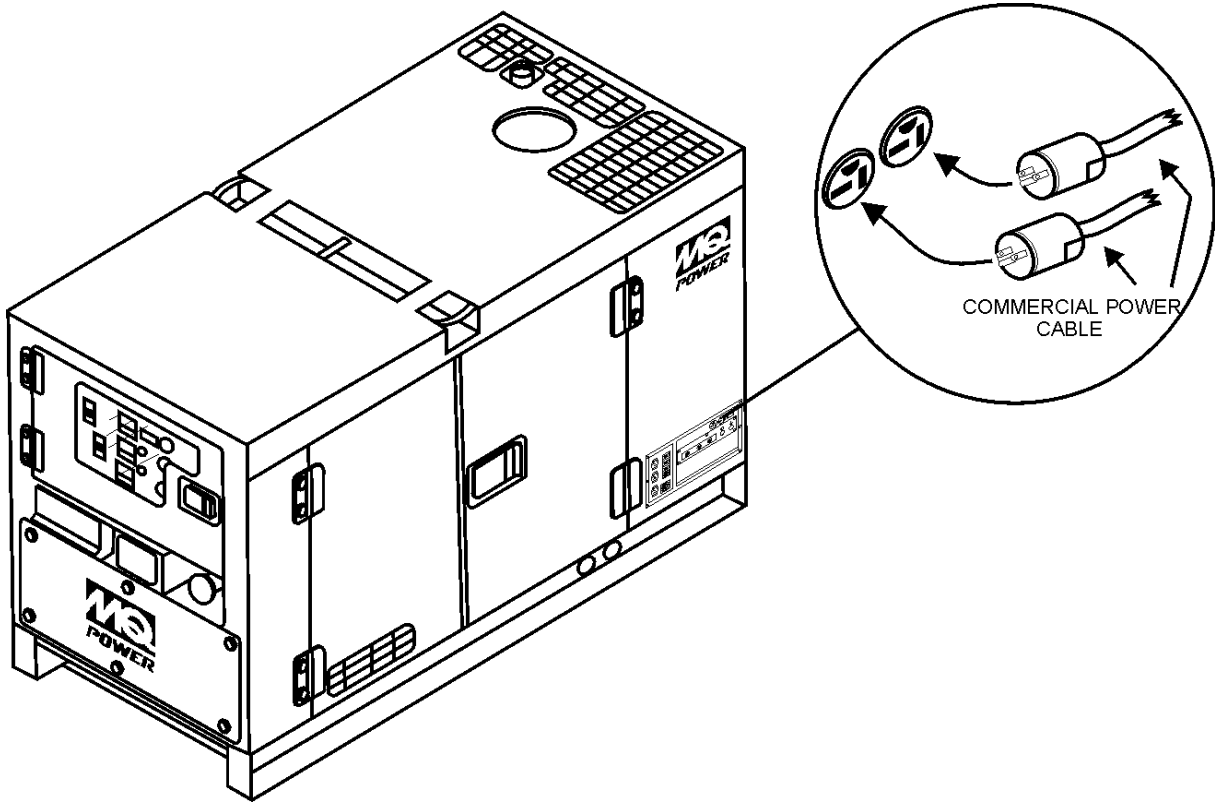
If the generator will be used daily, the battery should normally not require charging. If the generator will be idle (not used) for long periods of time, apply power to the battery charger receptacle via commercial power using an power cord of adequate size.

When connecting the generator to a isolation (transfer) switch, **ALWAYS** have power applied to the generator's internal battery charger. This will ensure that the engine will not fail due to a dead battery.

## CAUTION:

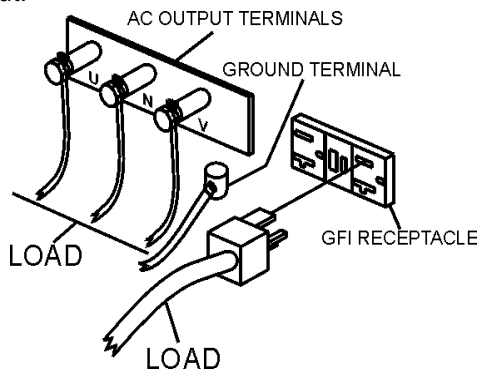


**ALWAYS** have power applied to the generator's internal battery charger when connecting the generator to a isolation (transfer) switch. Remember before connecting this generator to any buildings electrical system, have a **licensed** electrician perform the installation of the transfer switch.

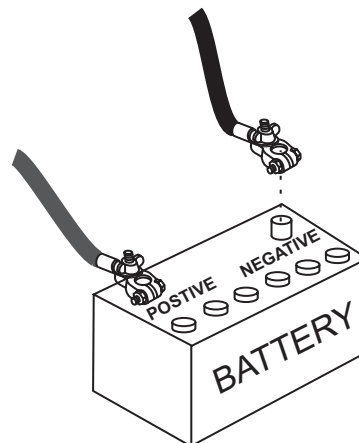


**Figure 21. VAC Accessory Receptacle/Cable**

2. Once it is determined if commercial power is required, connect the load to the UNV terminals as shown in Figure 22. These terminals can be found on the output terminal panel, see page 34 Figure 13. To gain access to the output terminals lift the UNV cover. Make sure to tighten terminal nuts securely to prevent load wires from slipping out.
3. Connect the negative battery cable (BLACK) to the negative post on the battery (Figure 23).



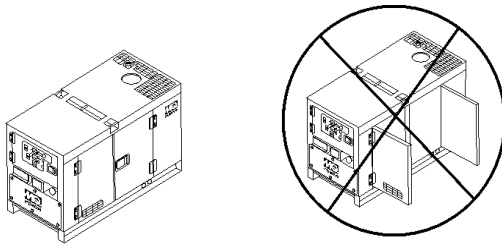
**Figure 22. UNV Terminal Lugs (Load)**



**Figure 23. Battery Connections**

# DCA-125SSJU — GENERATOR START-UP PROCEDURE (MANUAL)

4. Close all engine enclosure doors (Figure 24).



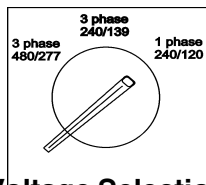
**CORRECT**                      **INCORRECT**  
**Figure 24. Engine Enclosure Doors**

5. When starting the generator in **COLD** weather conditions, press and hold the engine preheat button (Figure 25).



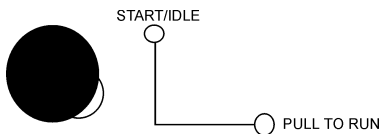
**Figure 25. Engine Pre-Heat Button**

6. Check the voltage selection switch is at the desired voltage (Figure 26).



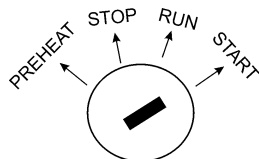
**Figure 26. Voltage Selection Switch**

7. If the generator is equipped with an engine throttle lever, make sure the lever is pushed in and set to 'IDLE' (Figure 27).



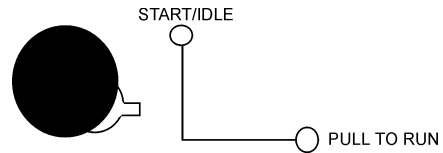
**Figure 27. Engine Throttle Lever (IDLE)**

8. If the generator has a starter switch, turn the key to 'START' (Figure 28) until the engine starts. Then release the key to set it at 'OPERATION' function.



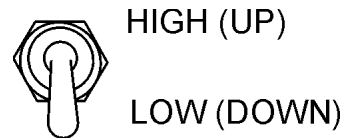
**Figure 28. Engine Speed Switch (low)**

9. Once the engine is warm and the engine is running properly, pull and turn the lever to 'RUN' (Figure 29).



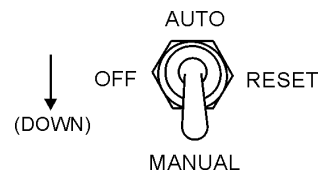
**Figure 29. Engine Speed Switch (low)**

10. If the generator is equipped with a Microprocessor Engine Control unit (MPEC), set engine speed switch to 'Low' (Figure 30).



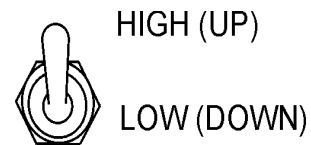
**Figure 30. Engine Speed Switch (low)**

11. Turn the Auto-Off/Reset-Manual switch to 'Manual' to start the engine (Figure 31). Once the engine starts, let the engine run for 1-2 minutes. Listen for any abnormal noises.



**Figure 31. Auto-Off/Reset-Manual Switch**

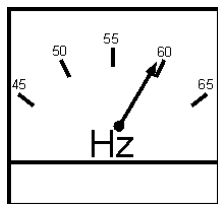
12. Once the engine is warm and the engine is running properly, set the engine speed switch to 'High' (Figure 32).



**Figure 32. Engine Speed Switch (high)**

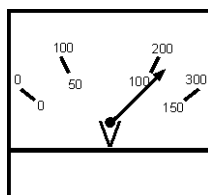
# DCA-125SSJU — GENERATOR START-UP PROCEDURE (MANUAL)

13. The generator's frequency meter (Figure 33) displays the 60 cycle output frequency in **HERTZ**.

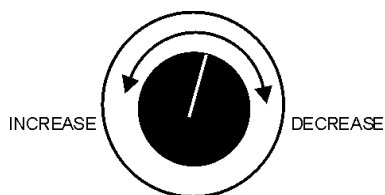


**Figure 33. Frequency Meter (Hz)**

14. The generator's voltage meter (Figure 34) displays the 120 VAC in **VOLTS**. If the voltage is not within the specified frequency tolerance, use the voltage adjustment control knob (Figure 35) to increase or decrease the desired voltage.

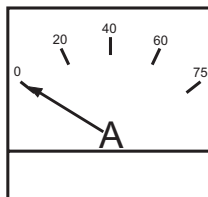


**Figure 34. Engine Speed Switch (low)**



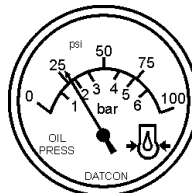
**Figure 35. Voltage Adjust Control Knob**

15. The ammeter (Figure 36) will indicate zero amps with no load applied. When a load is applied, this meter will indicate the amount of current that the load is drawing from the generator's alternator.



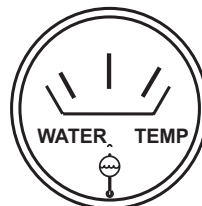
**Figure 36. Ammeter (No Load)**

16. The engine oil pressure gauge (Figure 37) will indicate the oil pressure (kg/ cm<sup>2</sup>) of the engine. Under normal operating conditions the oil pressure is approximately 25 psi.



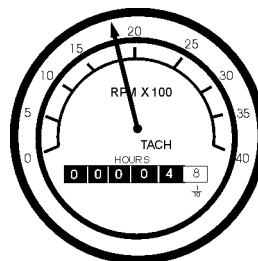
**Figure 37. Oil Pressure Gauge**

17. The coolant temperature gauge (Figure 38) will indicate the coolant temperature. Under normal operating conditions the coolant temperature is between 165 and 215 degrees fahrenheit.



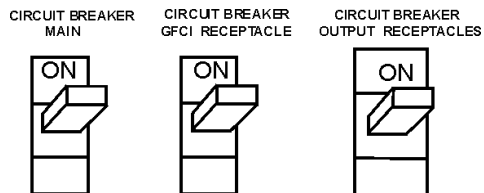
**Figure 38. Coolant Temperature Gauge**

18. The tachometer (Figure 39) will indicate the speed of the engine when the generator is operating. Under normal operating conditions this speed is approximately 1800 RPM's.



**Figure 39. Engine Tachometer**

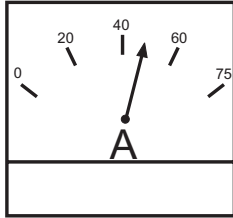
19. Turn the MAIN, GFCI and LOAD circuit breakers to their ON position (Figure 40).



**Figure 40. Main and GFCI Circuit Breakers**

# DCA-125SSJU — GENERATOR START-UP PROCEDURE (AUTO)

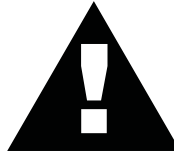
20. Observe the generator's ammeter (Figure 41) and verify it reads the anticipated amount of current with respect to the load. The ammeter will only display a current reading if the load is in use.



**Figure 41. Ammeter (Load)**

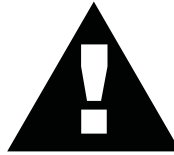
21. The generator will run until manually stopped or an abnormal condition occurs.

## CAUTION:



Before connecting this generator to any building's electrical system, a **licensed electrician** must install an isolation (transfer) switch. Serious ***injury*** or ***death*** may result without this transfer switch.

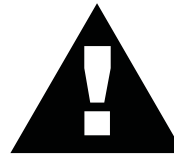
## CAUTION:



When connecting the generator to a isolation (transfer) switch, **ALWAYS** have power applied to the generator's internal battery charger. This will ensure that the engine will not fail due to a dead battery.

Starting the generator in the "AUTO" mode is similar to starting the generator in the "MANUAL" mode, with a few exceptions.

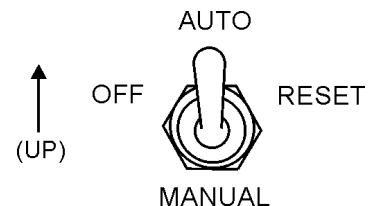
## CAUTION:



When running the generator in the **AUTO** mode, remember the generator can start up at any time without warning. **NEVER** attempt to perform any maintenance when the generator is in the auto mode.

When starting generator in Auto mode use the "Manual Start-up" procedure except where noted (see below).

1. Perform steps 1 through 10 (Before Starting, page 43-45) as outlined in the manual starting procedure.
2. Place the Off/Manual/Auto switch (Figure 42) in the **AUTO** position (up).



**Figure 42. Off/Manual Auto Switch (AUTO)**

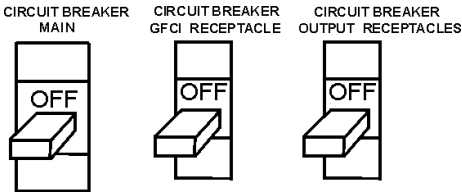
3. Continue to follow the steps outline in the manual start-up procedure (start at step 12, page 45).

# DCA-125SSJU — GENERATOR SHUT-DOWN PROCEDURE

## ENGINE SHUTDOWN

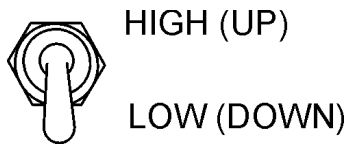
To shutdown the generator, use the following procedure:

1. Switch both the MAIN, GFCI and LOAD circuit breakers (Figure 43) to the "OFF" position.



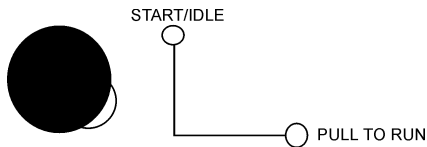
**Figure 43. Main, GFCI and Load circuit breakers**

2. Set the engine speed switch (Figure 44) to the idle (low) position.



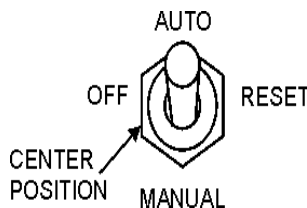
**Figure 44. Engine Speed Switch**

3. If the engine is equipped with the engine throttle lever, turn and push to 'IDLE' position (Figure 45).



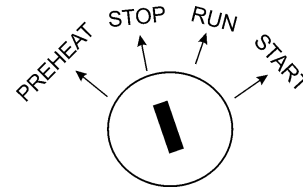
**Figure 45. Engine Throttle Lever (IDLE)**

4. Let the engine cool by running it for 3-5 minutes with no load applied.
5. Turn the Auto-Off/Reset-Manual switch from the MPEC to "OFF/Reset" position (Figure 46).



**Figure 46. Off/Manual Auto Switch**

6. If the engine is equipped with the engine throttle lever, turn the key to "STOP" position (Figure 47).



**Figure 47. Engine Starter Switch (STOP)**

7. Remove the load from the UNV terminal strip.



## General Inspection

Prior to each use, the generating set should be cleaned and inspected for deficiencies. Check for loose, missing or damaged nuts, bolts or other fasteners. Also check for fuel or oil leaks.

**Engine Side, Fuel, Oil and Coolant** (Refer to the Engine Instruction Manual)

## Air Cleaner

Every 50 hours: Remove air cleaner element and clean heavy duty paper element with kerosene, or foam element with liquid detergent and hot water. Wrap foam element in a cloth and squeeze dry. For heavy duty paper element, wipe excess kerosene with towel.

## Fuel Addition

Add diesel fuel (the grade may vary according to season and locations). Always pour through the mesh filter.

## Removing Water from the Tank

After prolonged use, water and other impurities accumulate in the bottom of the tank. Occasionally remove the drain cock and drain the contents. During cold weather, the greater the empty volume inside the tank, the easier it is for water to condense. This can be reduced by always keeping the tank as full as possible.

## Air Removal

If air enters the fuel injection system of a diesel engine, starting becomes impossible. After running out of fuel, or after disassembling the fuel system, bleed the system according to the following procedure.

To restart after running out of fuel, turn the key switch to the "START" position for 15-30 seconds. Try again, if needed. This unit is equipped with an automatic air bleeding system.

## Service Daily

If engine is operating in very dusty and dry grass conditions, a clogged air cleaner will result in high fuel consumption, loss of power and excessive carbon buildup in the combustion chamber.

## Cleaning the Fuel Strainer

Clean the fuel strainer if it contains dust or water. Remove dust or water in the strainer cap and wash it in diesel. Securely fasten the fuel strainer cap so that fuel will not leak. Check the fuel strainer every 200 hours of operation or once a month.

## Check Oil Level

Check the crankcase oil level prior to each use, or when the fuel tank is filled. Insufficient oil may cause severe damage to the engine. Make sure the generator is level. The oil level must be between the two notches on the dipstick as shown in Figure 17, page 39.

For storage of the generator for over 30 days, the following is required:

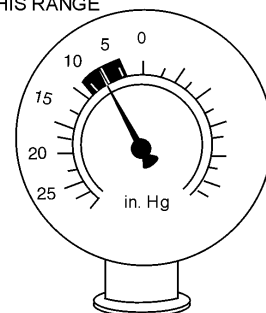
- Drain the fuel tank completely.
- Completely drain the oil from the crankcase and refill with fresh oil.
- Clean all external parts of the generator with a cloth.
- Cover the generating set and store in a clean, dry place.

## Water Separator Filter

Replace the water separator filter (Figure 44) every 500 hours if two filters are being used. If one filter is being used, replace every 250 hours.

The filters should also be replaced if the vacuum gauge indicates between 6 to 10 inches of mercury (in. Hg.)

6-10 In. Hg.  
REPLACE WATER  
SEPARATOR FILTER  
IF GAUGE READS  
IN THIS RANGE



**Figure 44. Water Separator Gauge**

To replace the **water separator filter** element perform the following:

1. Remove the lid from the filter housing. Remove the element by holding the module handle and slowly pulling upward with a twisting motion.
2. Replace the lid gasket with the one supplied with the new filter element. Apply a coating of clean fuel or motor oil to seal prior to reassembly. Insert the new filter element with a slow downward twisting motion.
3. Fill the unit with clean fuel, then set the lid back on top of the filter housing, and tighten snugly using the T-bar handle.
4. Start the engine and check for any leaks. If any leaks occur with the engine running, turn the engine off and fix the leak.

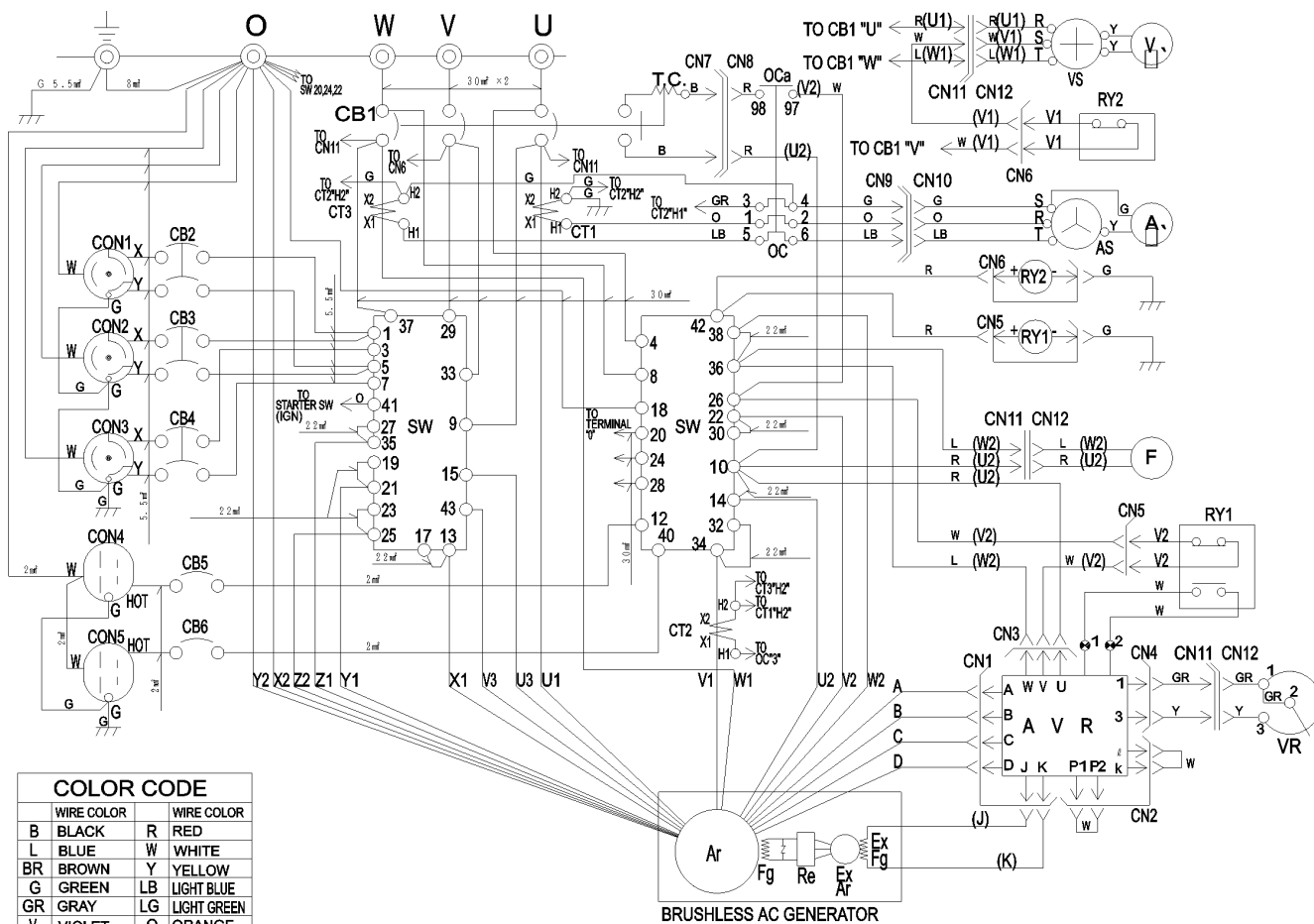
INSPECTION / MAINTENANCE		10 Hrs DAILY	250 Hrs	500 Hrs	1000 Hrs
ENGINE	Check Engine Fluid Levels	X			
	Check Air Cleaner	X			
	Check Battery Acid Level	X			
	Check Fan Belt Condition	X			
	Check for Leaks	X			
	Check for Loosening of Parts	X			
	Check Water Separator	X			
	Check Blow-by Oil Mist Tank	X			
	Replace Engine Oil and Filter *1		X		
	Clean Air Filter		X		
	Drain Bottom of Fuel Tank		X		
	Clean Unit, Inside and Outside		X		
	Change Fuel Filter *2			X	
	Replace Water Separator Element *3		(X)	X	
	Clean Radiator and Check Coolant Protection Level			X	
	Replace Air Filter Element				X
	Change Corrosion Resistor				X
	Check all Hoses and Clamps				X
Clean Inside of Fuel Tank				X	
GENERATOR	Measure Insulation Resistance Over 3M ohms		X		

\*1 Replace engine oil and filter at 100 hours, first time only.

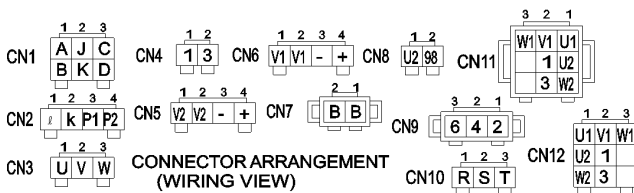
\*2 Replace fuel filter at 250 Hours, first time only.

\*3 Refer to the item "Water Separator Filter".

# DCA-125SSJU — GENERATOR WIRING DIAGRAM



COLOR CODE			
WIRE COLOR		WIRE COLOR	
B	BLACK	R	RED
L	BLUE	W	WHITE
BR	BROWN	Y	YELLOW
G	GREEN	LB	LIGHT BLUE
GR	GRAY	LG	LIGHT GREEN
V	VIOLET	O	ORANGE
P	PINK		



SYMBOL	DESIGNATION
Ar	MAIN GENERATOR ARMATURE WINDING
Fg	MAIN GENERATOR FIELD WINDING
ExAr	EXCITER ARMATURE WINDING
ExFg	EXCITER FIELD WINDING
Re	RECTIFIER
AVR	AUTOMATIC VOLTAGE REGULATOR
VR	VOLTAGE REGULATOR (RHEOSTAT)
CT 1,2,3	CURRENT TRANSFORMER
AS	CHANGE-OVER SWITCH, AMMETER
A	AC AMMETER
VS	CHANGE-OVER SWITCH, VOLTMETER
V	AC VOLTMETER
F	FREQUENCY METER
CB1	CIRCUIT BREAKER
CB2,3,4	CIRCUIT BREAKER
CB5,6	CIRCUIT BREAKER
CON1,2,3	RECEPTACLE
CON4,5	RECEPTACLE
OC	OVER CURRENT RELAY
SW	SELECTOR SWITCH
RY1,2	RELAY UNIT

Notice :  
1. No designation lead size : 1.25



## DCA-125SSJU — TROUBLESHOOTING (ENGINE)

Practically all breakdowns can be prevented by proper handling and maintenance inspections, but in the event of a breakdown, use the tables shown for

diagnosis based on the Engine Troubleshooting (Table14). If the problem cannot be remedied, consult our company's business office or service plant.

**TABLE 14. ENGINE TROUBLESHOOTING**

SYMPTOM	POSSIBLE PROBLEM	SOLUTION
Engine does not start.	No fuel?	Replenish fuel.
	Air in the fuel system?	Bleed system.
	Water in the fuel system?	Remove water from fuel tank.
	Fuel pipe clogged?	Clean fuel pipe.
	Fuel filter clogged?	Clean or change fuel filter.
	Excessively high viscosity of fuel or engine oil at low temperature?	Use the specified fuel or engine oil.
	Fuel with low cetane number?	Use the specified fuel.
	Fuel leak due to loose injection pipe retaining nut?	Tighten nut.
	Incorrect injection timing?	Adjust.
	Fuel cam shaft worn?	Replace.
	Injection nozzle clogged?	Clean injection nozzle.
	Injection pump malfunctioning?	Repair or replace.
	Seizure of crankshaft, camshaft, piston, cylinder liner or bearing?	Repair or replace.
	Compression leak from cylinder?	Replace head gasket, tighten cylinder head bolt, glow plug and nozzle holder.
	Improper valve timing?	Correct or replace timing gear.
Piston ring and liner worn?	Replace.	
Excessive valve clearance?	Adjust.	
Starter does not run.	Starter malfunctioning?	Repair or replace.
	Wiring disconnected?	Connect wiring.

## TABLE 14. ENGINE TROUBLESHOOTING (CONTINUED)

SYMPTOM	POSSIBLE PROBLEM	SOLUTION
Engine revolution is not smooth.	Fuel filter clogged or dirty?	Clean or change.
	Air cleaner clogged?	Clean or change.
	Fuel leak due to loose injection pipe retaining nut?	Tighten nut.
	Injection pump malfunctioning?	Repair or replace.
	Incorrect nozzle opening pressure?	Adjust.
	Injection nozzle stuck or clogged?	Repair or replace.
	Fuel over flow pipe clogged?	Clean.
	Governor malfunctioning?	Repair.
Either white or blue exhaust gas is observed.	Excessive engine oil?	Reduce to the specified level.
	Piston ring and liner worn or stuck?	Repair or replace.
	Incorrect injection timing?	Adjust.
	Deficient compression?	Adjust top clearance.
Either black or dark gray exhaust gas is observed.	Overload?	Lessen the load.
	Low grade fuel used?	Use the specified fuel.
	Fuel filter clogged?	Clean or change.
	Air cleaner clogged?	Clean or change.
	Deficient nozzle injection?	Repair or replace the nozzle.
Deficient output.	Incorrect injection timing?	Adjust.
	Engine's moving parts seem to be seizing?	Repair or replace.
	Uneven fuel injection?	Repair or replace the injection pump.
	Deficient nozzle injection?	Repair or replace the nozzle.
	Compression leak?	Replace head gasket, tighten cylinder head bolt, glow plug and nozzle holder.

# DCA-125SSJU — TROUBLESHOOTING (GENERATOR/ENGINE)

Practically all breakdowns can be prevented by proper diagnosis based on the Engine and Radiator Troubleshooting (Table15) and MPEC Troubleshooting (Table16). If the problem cannot be remedied, consult our company's business office or service plant.

**TABLE 15. ENGINE & GENERATOR TROUBLESHOOTING**

SYMPTOM	POSSIBLE PROBLEM	SOLUTION
Engine fails to start and starter does not rotate.	Dead battery?	Replace battery.
	Defective starter switch?	Replace switch.
	Fuse F5 burned out?	Replace fuse.
Engine fails to start and starter rotates.	Broken pre-heat circuit?	Check pre-heat circuit.
	No fuel?	Add fuel.
	Defective wiring?	Check wiring.
Engine starts and remains at low speed.	Clogged fuel strainer?	Clean or replace.
	Clogged air cleaner?	Clean or replace.
	Disconnected wiring?	Check and repair wiring.
Engine speed rises and no voltage is present in AC power source.	No voltage present in AC power source?	Replace rectifier (RE1).
	Defective rotor?	Replace rotor.
	Defective voltmeter?	Replace voltmeter.
	Disconnected wiring?	Check and repair wiring.
	Layer short-circuit in armature winding?	Replace armature.
Engine speed rises and AC power voltage is too low or cannot be used.	Defective circuit breaker (protector)?	Replace circuit breaker (protector).
	Layer short-circuit, broken wires in armature winding?	Repair or replace armature.
Engine speed rises and battery discharges too soon.	Defective engine regulator?	Replace regulator.
	Defective wiring?	Repair or replace wiring.
Engine speed rises and engine seems overloaded.	Defective alternator?	Repair or replace alternator.
	Damaged alternator bearing?	Replace alternator bearings.

## TABLE 16. MPEC TROUBLESHOOTING

Sympton	Possible Cause	Solution
Low oil pressure light is on.	Low oil level?	Fill oil level.
	Oil pressure sending unit failure?	Replace oil pressure sending unit.
	Time delay malfunction in MPEC?	Refer to dealer.
	Wire shorted?	Inspect/repair wire.
Low coolant level light is on.	Low coolant level?	Fill coolant level.
	Sending unit failure?	Replace sending unit.
	Low battery voltage?	Replace/charge battery.
High coolant temperature light is on.	Fan belt tension incorrect?	Tighten/replace fan belt.
	Air flow is not circulation through radiator?	Clean/repair radiator grill.
	Doors open?	Close doors.
	Exhaust leaking?	Replace/repair gaskets or faulty part.
	Generator being overloaded?	Check/reduce load.
	Thermostat failure?	Replace thermostat.
	Air intake blocked?	Clear all air intakes.
Overcrank light is on.	No or low Fuel?	Fill fuel level.
	MPEC needs to be calibrated?	Refer to dealer.
Overspeed light is on.	RPM engine speed too high?	Adjust RPM.
	Governor actuator needs to be adjusted?	Adjust governor actuator.
	Governor controller needs to be adjusted?	Adjust governor controller.
	MPEC needs to be calibrated?	Refer to dealer.
Loss of MPU light(s) or on.	Magnetic pick up out of adjustment?	Adjust magnetic pick up.
	Magnetic pick up dirty?	Clean magnetic pick up.

## EXPLANATION OF CODE IN REMARKS COLUMN

How to read the marks and remarks used in this parts book.

### Items Found In the “Remarks” Column

**Serial Numbers**-Where indicated, this indicates a serial number range (inclusive) where a particular part is used.

**Model Number**-Where indicated, this shows that the corresponding part is utilized only with this specific model number or model number variant.

### Items Found In the “Items Number” Column

All parts with same symbol in the number column, \*, #, +, %, or ■, belong to the same assembly or kit.

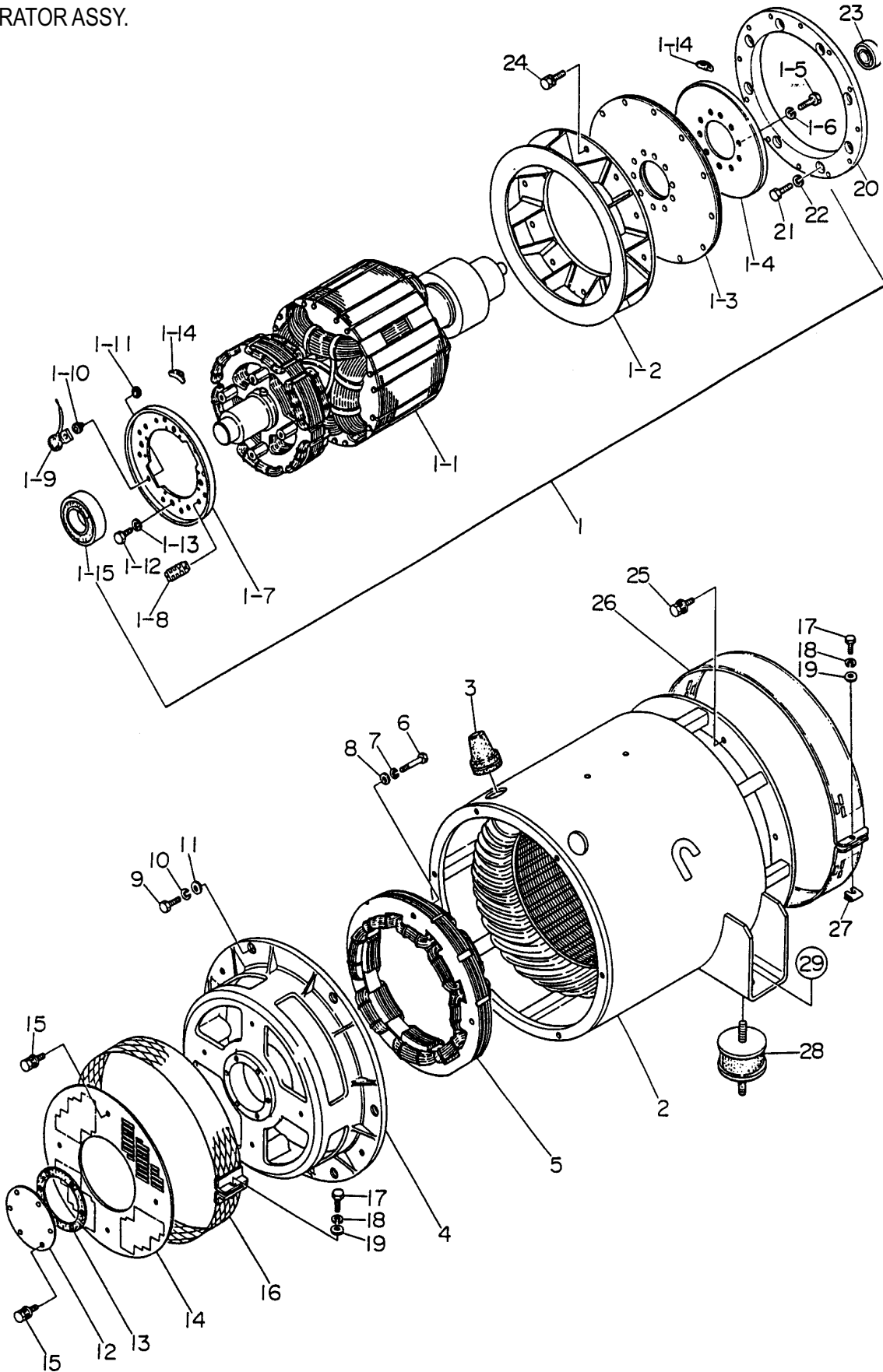
Note: If more than one of the same reference number is listed, the last one listed indicates newest (or latest) part available.

**DCA-125SSJU WJOHN DEERE DIESEL 6068TF ENGINE****1 to 5 Units**

<b>Qty.</b>	<b>P/N</b>	<b>Description</b>
10	6125817032	AIR FILTER
10	6003118293	FUEL FILTER
10	6002111231	OIL FILTER
5	6004111020	CARTRIDGE, CORROSION RESISTOR
1	0601805950	MAIN CIRCUIT BREAKER
1	0602115008	PILOT LAMP, ENGINE TROUBLE
2	0601810204	BULB
2	0412122262	ENGINE FAN BELT
2	6008711170	OIL SWITCH
1	6151619320	RADIATOR HOSE (UPPER)
1	6151619330	RADIATOR HOSE (LOWER)
1	0845500104	FUEL CAP
1	0601820625	AUTOMATIC VOLTAGE REGULATOR
1	0601807030	MAIN CIRCUIT BREAKER
1	0601840073	VOLTAGE REGULATOR (RHEOSTAT)
1	0601840121	KNOB, VOLTAGE REGULATOR
1	0601810072	PILOT LAMP
2	0601810261	BULB, PILOT LAMP
1	TR60110235100	CAP, RADIATOR
1	0602122200	UNIT, OIL PRESSURE
1	0602123204	UNIT, WATER TEMPERATURE
1	0602121052	CHARGING AMMETER
1	ECU9988N	ENGINE CONTROLLER

# DCA-125SSJU- GENERATOR ASSY.

GENERATOR ASSY.



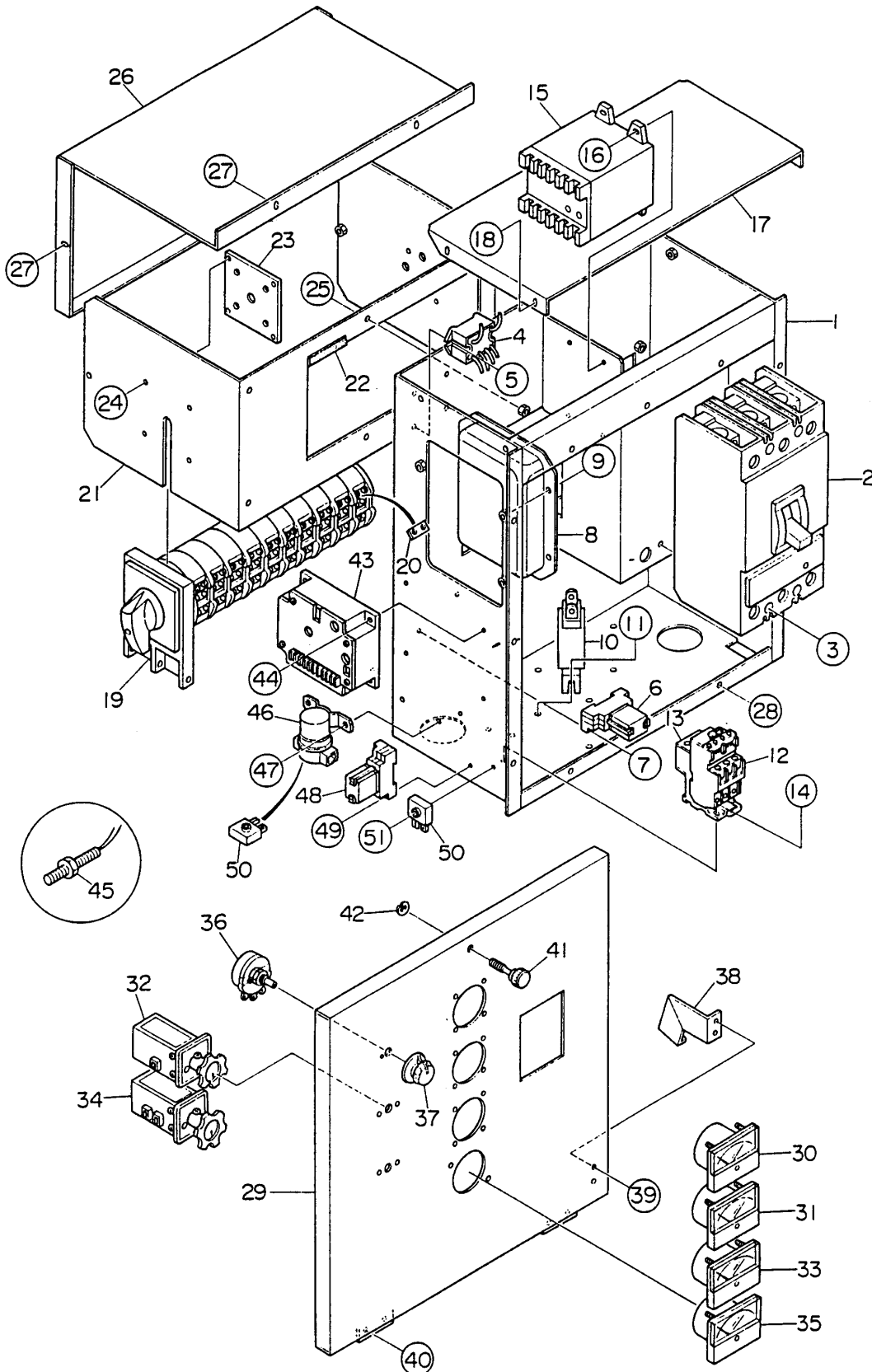
# DCA-125SSJU- GENERATOR ASSY.

GENERATOR ASSY.

<u>NO.</u>	<u>PART NO.</u>	<u>PART NAME</u>	<u>QTY.</u>	<u>REMARKS</u>
1	C011000002	ROTOR ASS'Y	1	
1-1		FIELD ASS'Y	1	
1-2	8131070013	FAN	1	
1-3	8131611014	COUPLING DISK	8	
1-4	8131015003	BALANCING PLATE	1	
1-5	0012112035	HEX. HEAD BOLT	10	
1-6	0042612000	LOCK WASHER	10	
1-7	8101026013	SET PLATE	1	
1-8	0601821349	RECTIFIER .....	2	PT3610
1-9	0601822601	SURGE ABSORBER .....	1	ERZM14JK621A
1-10	8001020004	INSULATOR WASHER	1	
1-11	8001020504	INSULATOR WASHER	1	
1-12	0010110020	HEX. HEAD BOLT	4	
1-13	0040010000	SPRING WASHER	4	
1-14	0601000209	BALANCING WEIGHT KIT	1	
1-15	0071906312	BEARING .....	1	6312 DDU C3
2	8131340213	STRATOR ASSY.	1	
3	0845041804	GROMMET	2	
4	8131315202	END BRACKET	1	
5	8101350013	FIELD ASSY. EXCITER	1	
6	0012110060	HEX. HEAD BOLT	4	
7	0042610000	LOCK WASHER	4	
8	031110160	PLAIN WASHER .....	4	REPLACES 0041210000
9	0010112035	HEX. HEAD BOLT	6	
10	0040012000	SPRING WASHER	6	
11	031112230	PLAIN WASHER .....	6	REPLACES 0041212000
12	8131310104	COVER, BEARING	1	
13	8131312204	GASKET, BEARING	1	
14	8131331003	COVER, END BRACKET	1	
15	0105050616	HEX. HEAD BOLT .....	10	REPLACES 0017106012
16	8101333003	COVER, END BRACKET	1	
17	0010106030	HEX. HEAD BOLT	2	
18	0040006000	LOCK WASHER	2	
19	952404470	PLAIN WASHER .....	2	REPLACES 0041206000
20	M3163400003	COUPLING RING	1	
21	0343204150	HEX. HEAD BOLT	8	
22	EM923344	LOCK WASHER .....	8	REPLACES 0043604000
23	0070506306	BEARING .....	1	6306ZZ
24	0012810030	HEX. HEAD BOLT	12	
25	0012810030	HEX. HEAD BOLT	12	
26	8131332014	COVER, FAN	1	
27	020106050	NUT .....	1	REPLACES 0600815000
28	0605000063	RUBBER SUSPENSION	2	
29	00300165000	HEX. NUT	2	
	0040016000	LOCK WASHER	2	

# DCA-125SSJU CONTROL BOX ASSY.

CONTROL BOX ASSY.S/N7500562~



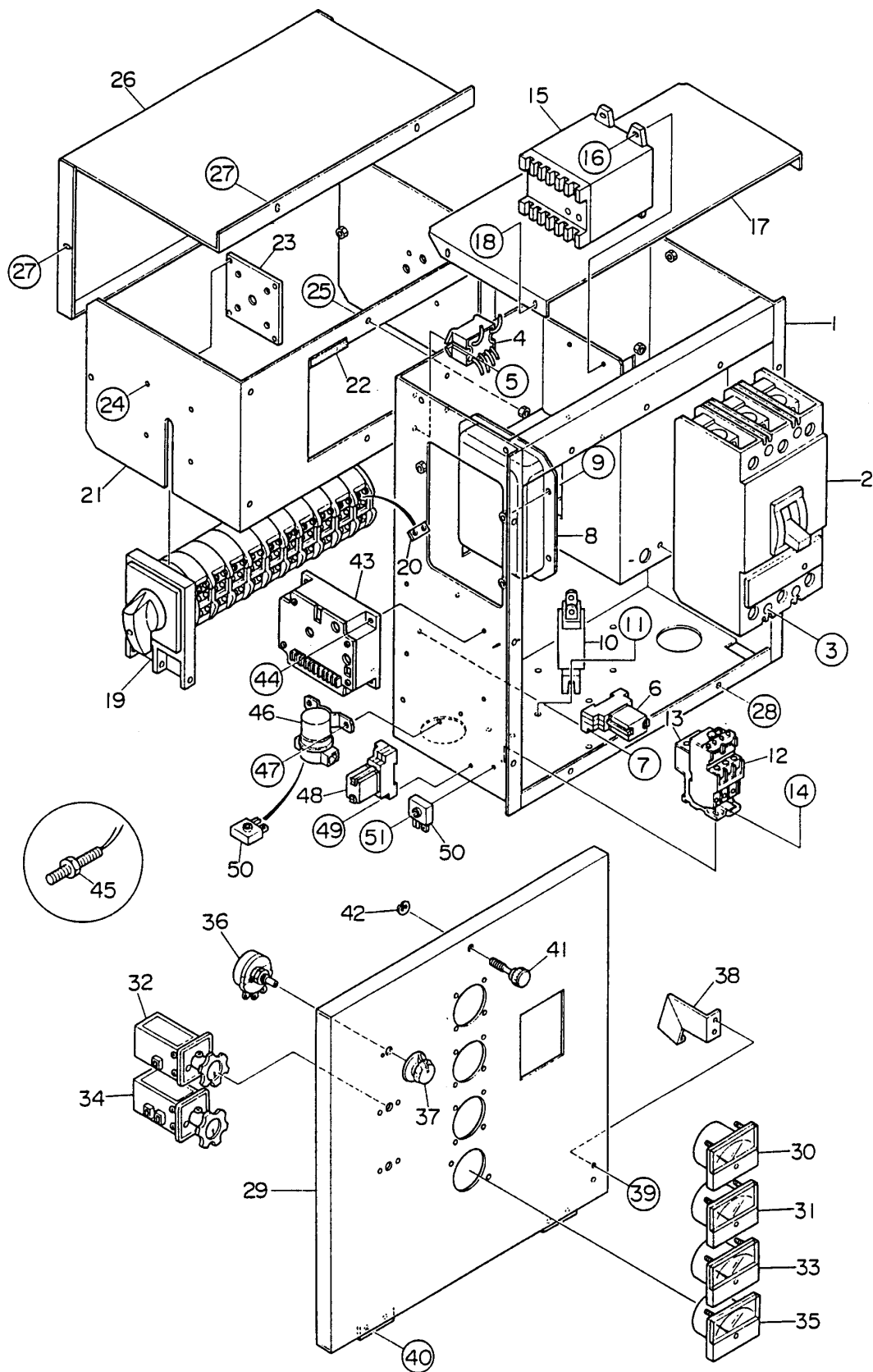
# DCA-125SSJU CONTROL BOX ASSY.

CONTROL BOX ASSY.S/N7500562~

<u>NO.</u>	<u>PART NO.</u>	<u>PART NAME</u>	<u>QTY.</u>	<u>REMARKS</u>
	M3248700104	WIRE HARNESS, GENERATOR	1	
1	M3215000002	CONTROL BOX	1	
2	0601808813	CIRCUIT BREAKER .....	1	LAF363001021 3P 300A
3	0021006080	MACHINE SCREW	4	
4	0601823863	RELAY UNIT .....	2	MSA9013A
5	0021304015	MACHINE SCREW .....	4	REPLACES 0027104015
6	LY2US12VDC	RELAY .....	1	REPLACES 0601823768
	PTF08AE	BASE .....	1	REPLACES 0601823109
	0601824400	CLIP .....	2	PYCA1
7	0027104020	MACHINE SCREW	2	
8	0601820671	AUTOMATIC VOLTAGE REGULATOR .....	1	NTA5A2DB
9	0027105015	MACHINE SCREW	4	
10	0601806118	CURRENT TRANSFORMER .....	3	814943 200/5A
11	011808015	MACHINE SCREW .....	6	REPLACES 0027106015
12	0601820845	OVER CURRENT RELAY .....	1	LR2D1308
13	0601820846	OVER CURRENT RELAY .....	1	LA7D1064
14	0021304015	MACHINE SCREW .....	2	REPLACES 0027104015
	0030004000	HEX. NUT .....	2	REPLACES 0207004000
15	0601808506	POWER TRANSDUCER .....	1	WT283S34015~1 5kW
16	0027105020	MACHINE SCREW	4	
17	M3213500013	CONTROL BOX COVER	1	
18	011106015	HEX. HEAD BOLT .....	4	REPLACES 0016906015
19	M3923100004	SELECTOR SWITCH .....	1	VY125
20	M3276600004	SPACER	8	
21	M3213600003	SWITCH BRACKET	1	
22	0330000295	EDGING	2	
23	M3260500004	SWITCH BOARD	1	
24	0020004010	MACHINE SCREW .....	4	REPLACES 0021104010
25	011106015	HEX. HEAD BOLT .....	6	REPLACES 0016906015
26	M3213600114	SWITCH COVER .....	1	REPLACES M3213600104
27	011106015	HEX. HEAD BOLT .....	4	REPLACES 0016906015
28	011106015	HEX. HEAD BOLT .....	10	REPLACES 0016906015
	0040506000	TOOTHED WASHER	1	
29	M3225000003	CONTROL PANEL	1	
30	0601807630	FREQUENCY METER .....	1	264250DJDJ9
31	0601808953	AC AMMETER .....	1	260240LSLS1JCA
32	0601801040	CHANGE-OVER SWITCH, AMMETER .....	1	SL2AS
33	0601806813	AC VOLTMETER .....	1	260244SJSJ1
34	0601801041	CHANGE-OVER SWITCH, VOLTMETER ....	1	SL2VS
35	0601870511	AC WATTMETER .....	1	LXK-8C 12~120kW
36	0601840073	RHEOSTAT (VOLTAGE REGULATOR) .....	1	RA20A2SE102BJ 2W 1k ohm
37	0601840121	KNOB	1	

# DCA-125SSJU-CONTROL BOX ASSY.

CONTROL BOX ASSY.S/N7500562~



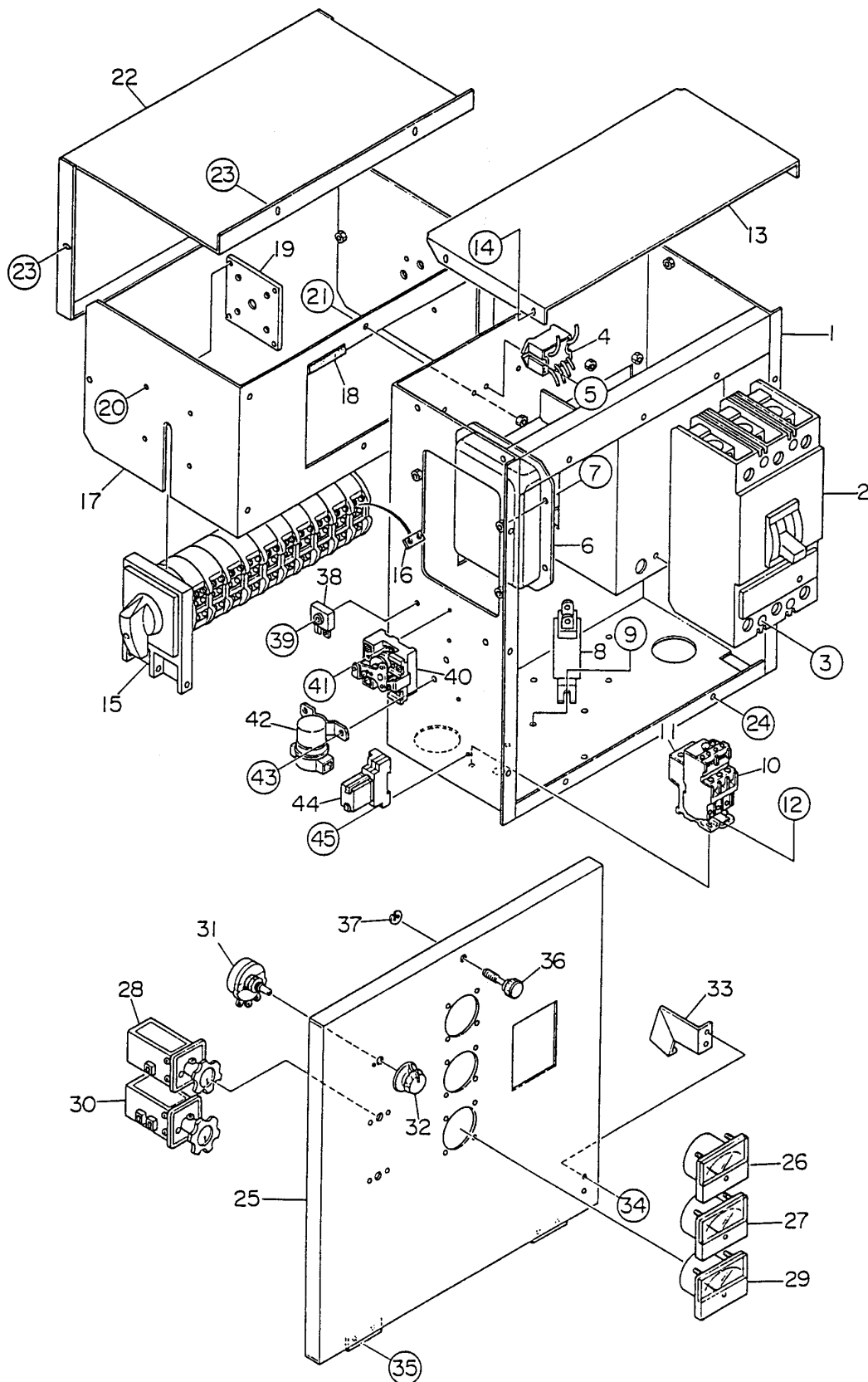
# DCA-125SSJU-CONTROL BOX ASSY.

CONTROL BOX ASSY.S/N7500562~

<u>NO.</u>	<u>PART NO.</u>	<u>PART NAME</u>	<u>QTY.</u>	<u>REMARKS</u>
38	M122310004	STOPPER	1	
39	0027105010	MACHINE SCREW	2	
40	0027105010	MACHINE SCREW	4	
41	M9220100004	SET SCREW	1	
42	0080200007	SNAP RING	1	
43	DYN110794000012	CONTROLLER.....	1	REPLACES 0602202599
44	0027405015	MACHINE SCREW	4	
45	MPS6724	SPEED SENSOR, MAGNETIC PICK UP ...	1	REPLACES 0602120485
46	0602202592	STARTER RELAY .....	1	AT141011
47	011808015	MACHINE SCREW	2	REPLACES 0027106015
48	LY2US12VDC	RELAY .....	1	REPLACES 0601827656
	PTF08AE	BASE .....	1	REPLACES 0601823109
	PYCA1	CLIP .....	2	REPLACES 0601824400
49	0027104020	MACHINE SCREW	2	
50	0601821370	RECTIFIER .....	2	REPLACES 0601823240
51	0027104020	MACHINE SCREW	1	

# DCA-125SSJU-CONTROL BOX ASSY.

CONTROL BOX ASSY.S/N7500283 TO S/N7500561



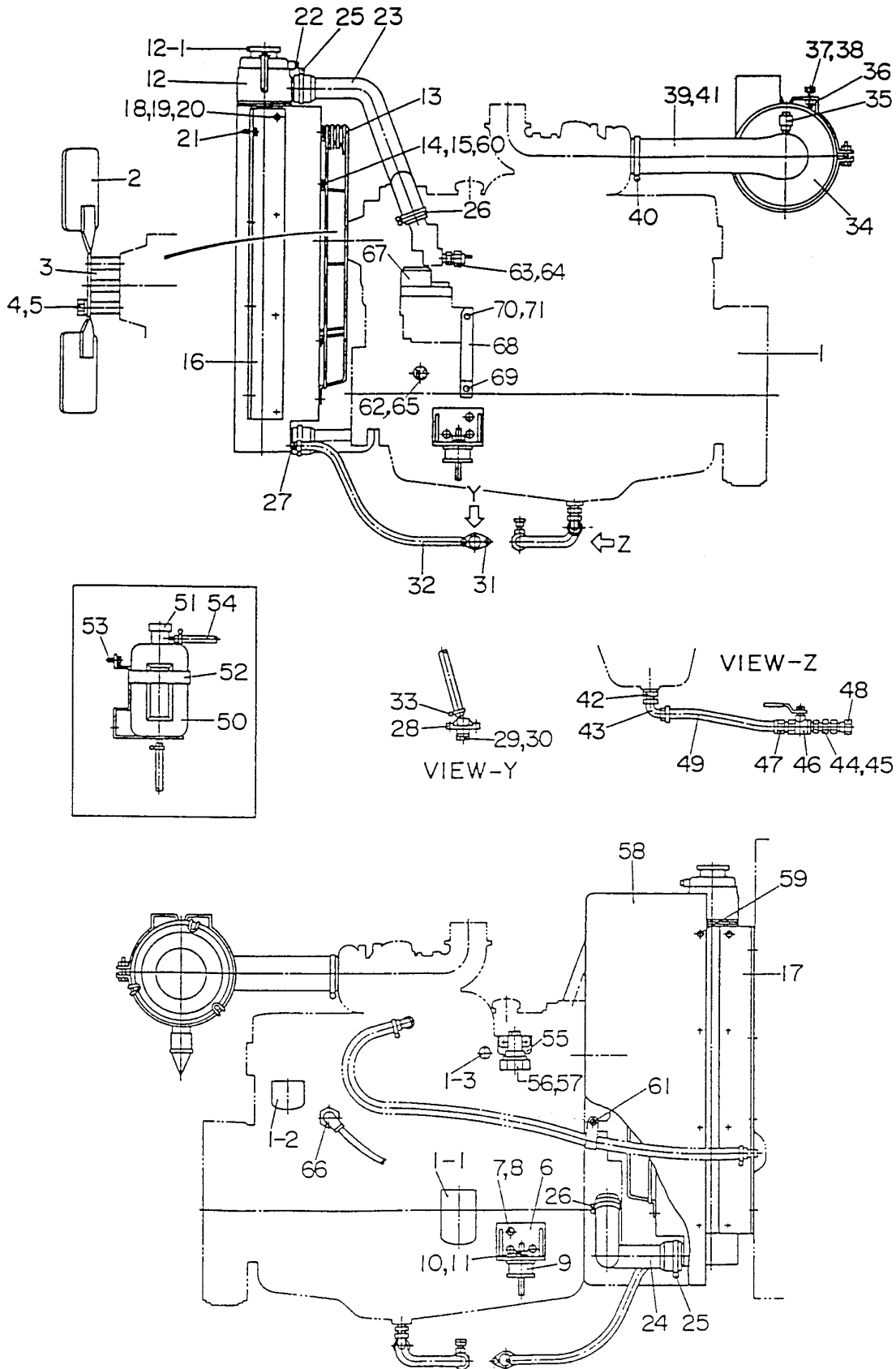
# DCA-125SSJU-CONTROL BOX ASSY.

CONTROL BOX ASSY.S/N7500283 TO S/N7500561

<u>NO.</u>	<u>PART NO.</u>	<u>PART NAME</u>	<u>QTY.</u>	<u>REMARKS</u>
	M3246700304	WIRE HARNESS, GENERATOR	1	
1	M3213000122	CONTROL BOX	1	
2	0601808813	CIRCUIT BREAKER .....	1	LAF363001021 3P 300A
3	0021006080	MACHINE SCREW	4	
4	0601823863	RELAY UNIT .....	2	MSA9013A
5	0027104015	MACHINE SCREW	4	
6	0601820671	AUTOMATIC VOLTAGE REGULATOR .....	1	NTA 5A2DB
7	0027105015	MACHINE SCREW	4	
8	0601806118	CURRENT TRANSFORMER .....	3	814943 200/5A
9	0027106015	MACHINE SCREW	6	
10	0601820845	OVER CURRENT RELAY .....	1	LR2D1308
11	0601820846	OVER CURRENT RELAY .....	1	LA7D1064
12	0027104015	MACHINE SCREW	2	
	0207004000	HEX. NUT	2	
13	M3213500013	CONTROL BOX COVER	1	
14	0016906015	HEX.HEAD BOLT	4	
15	M3923100004	SELECTOR SWITCH .....	1	VY125
16	M3276600004	SPACER	8	
17	M3213600003	SWITCH BRACKET	1	
18	0330000295	EDGES	2	
19	M3260500004	SWITCH BOARD	1	
20	0021104010	MACHINE SCREW	1	
21	0016906015	HEX. HEAD BOLT	6	
22	M3213600104	SWITCH COVER	1	
23	0016906015	HEX. HEAD BOLT	4	
24	0016906015	HEX. HEAD BOLT	10	
	0040506000	TOOTHED WASHER	1	
25	M3223000103	CONTROL PANEL	1	
26	0601807630	FREQUENCY METER .....	1	264250DJDJ9
27	0601808953	AC AMMETER .....	1	260240LSLS1JCA
28	0601801040	CHANGE-OVER SWITCH, AMMETER .....	1	SL2AS
29	0601806813	AC VOLTMETER .....	1	260244SJSJS1
30	0601801041	CHANGE-OVER SWITCH, VOLTMETER .....	1	SL2VS
31	0601840073	RHEOSTAT(VOLTAGE REGULATOR.....)	1	RA20A2SE102BJ 2W 1kOHM
32	0601840121	KNOB	1	
33	M1223100004	STOPPER	1	
34	0027105010	MACHINE SCREW	2	
35	0027105010	MACHINE SCREW	4	
36	M9220100004	SET SCREW	1	
37	0080200007	SNAP RING	1	
38	0601823240	RECTIFIER .....	1	DC4503
39	0027105020	MACHINE SCREW	1	
40	0601827680	RELAY .....	1	2024381
41	0027104015	MACHINE SCREW	2	
42	0602202592	STARTER RELAY .....	1	AT141011
43	0027106015	MACHINE SCREW	2	
44	0601823768	RELAY .....	1	LY2US12VD
	0601823109	BASE .....	1	PTF08AE
	0601824400	CLIP .....	2	PYCA1
45	0027104015	MACHINE SCREW	2	

# DCA-125SSJU ENGINE AND RADIATOR ASSY.

ENGINE AND RADIATOR ASSY. S/N75000562~



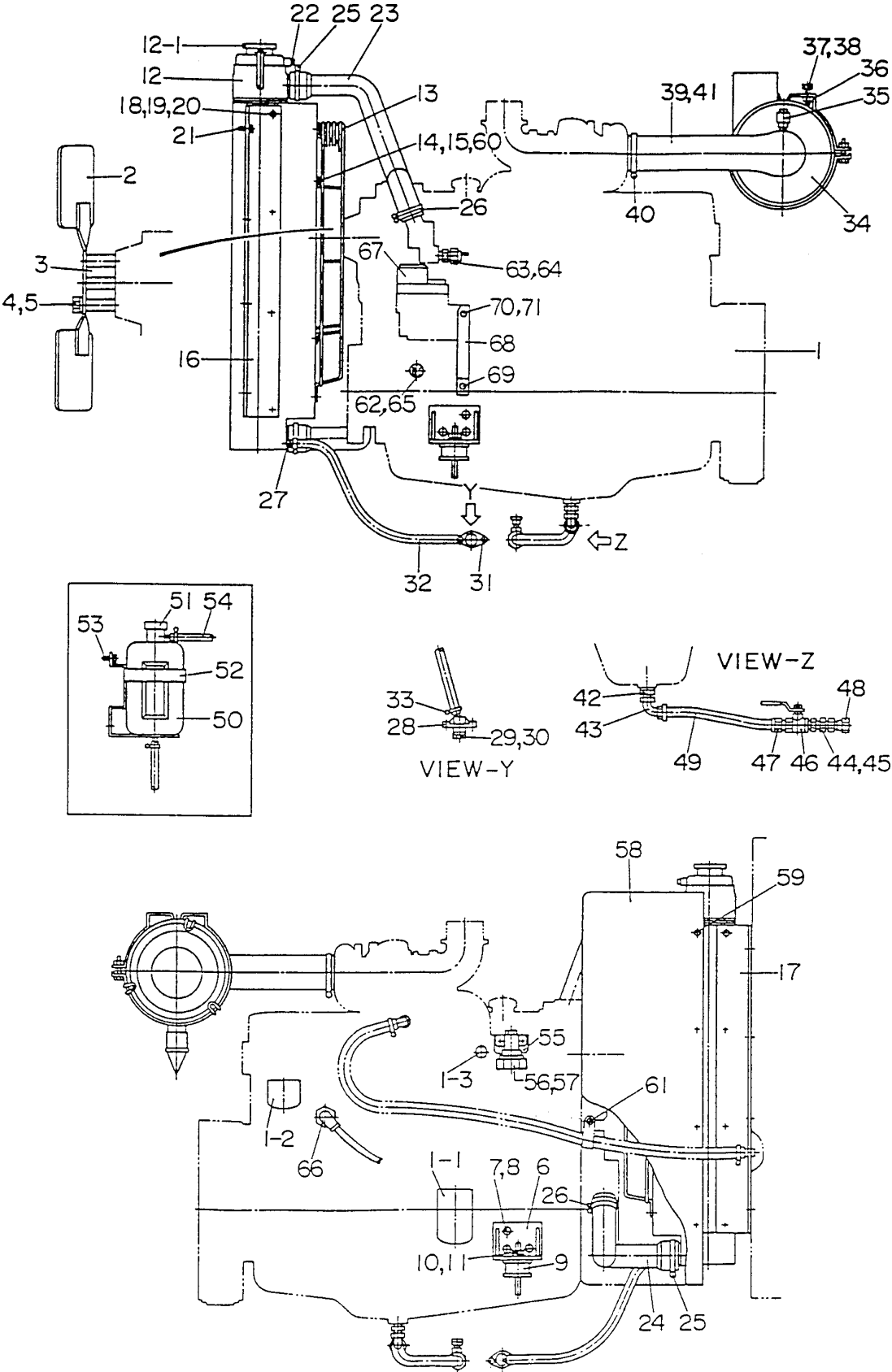
# DCA-125SSJU ENGINE AND RADIATOR ASSY.

ENGINE AND RADIATOR ASSY. S/N75000562~

<u>NO.</u>	<u>PART NO.</u>	<u>PART NAME</u>	<u>QTY.</u>	<u>REMARKS</u>
1	M3923200004	ENGINE .....	1	JOHN DEERE 6068TF
	0602011491	FAN BELT	1	
1-1	0602041290	ELEMENT, OIL FILTER .....	1	RE59754A
1-2	0602042590	ELEMENT, FUEL FILTER .....	1	RE62418
1-3	0602014287	ELECTRIC HEATER .....	1	RE502668
2	0602060010	BLOWER FAN .....	1	422198
3	0602061000	FAN SPACER .....	1	R81911
4	0012110095	HEX. HEAD BOLT	4	
5	030210250	LOCK WASHER .....	4	REPLACES 004251000
6	M2303200303	ENGINE FOOT	2	
7	0131151240	HEX HEAD BOLT .....	6	REPLACES 0010312030
8	0040012000	LOCK WASHER	6	
9	0605000060	RUBBER SUSPENSION	2	
10	0030012000	HEX. NUT	2	
11	0040012000	LOCK WASHER	2	
12	0602011988	RADIATOR .....	1	RE52824
12-1	0602011067	CAP .....	1	
13	0602010795	FAN COVER .....	1	C2810044210
14	0343006080	HEX. HEAD BOLT	8	
15	0043106000	PLAIN WASHER	8	
16	M331020024	RADIATOR BRACKET	1	
17	M3310200404	RADIATOR BRACKET	1	
18	0343006080	HEX.HEAD BOLT	8	
19	0043006000	LOCK WASHER	8	
20	0043106000	PLAIN WASHER	8	
21	0110080020	HEX. HEAD BOLT .....	8	REPLACES 0016908020
22	0138102000	PLUG	1	
23	M3310500103	RADIATOR HOSE	1	
24	M3310500103	RADIATOR HOSE	1	
25	0605515147	HOSE BAND	2	
26	0605515147	HOSE BAND	2	
27	0605512190	HOSE JOINT	1	
28	M2320300103	DRAIN JOINT	1	
29	M9200200004	DRAIN JOINT	1	
30	015000018	O RING .....	1	AP18
31	0016906020	HEX. HEAD BOLT	2	
32	0191300580	DRAIN HOSE	1	
33	0605515189	HOSE BAND	2	
34	0602046258	AIR CLEANER .....	1	FRG100297
	0602046377	INDICATOR, AIR CLEANER .....	1	RBX002252
36	0602040596	BAND, AIR CLEANER .....	1	P004076
37	0110080020	HEX. HEAD BOLT .....	4	REPLACES 0016908020
38	0207008000	HEX. NUT	4	
39	M3373100003	HOSE, AIR CLEANER	1	

# DCA-125SSJU ENGINE AND RADIATOR ASSY.

ENGINE AND RADIATOR ASSY. S/N7500562~



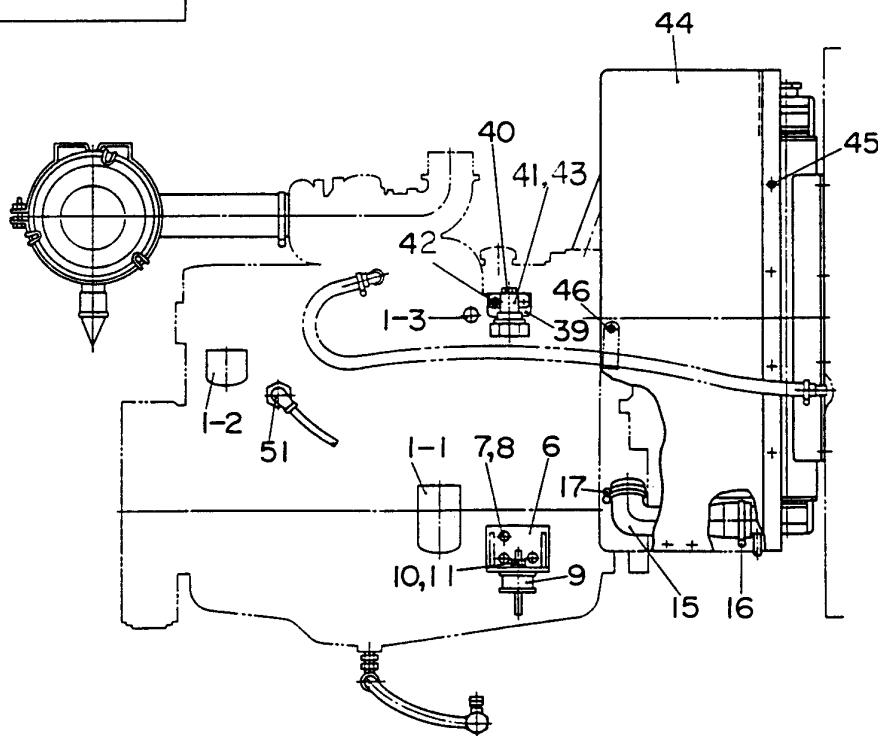
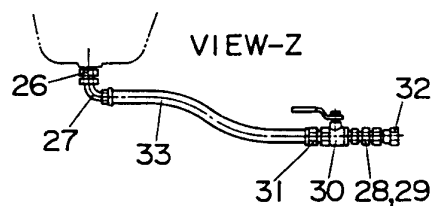
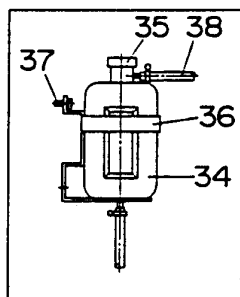
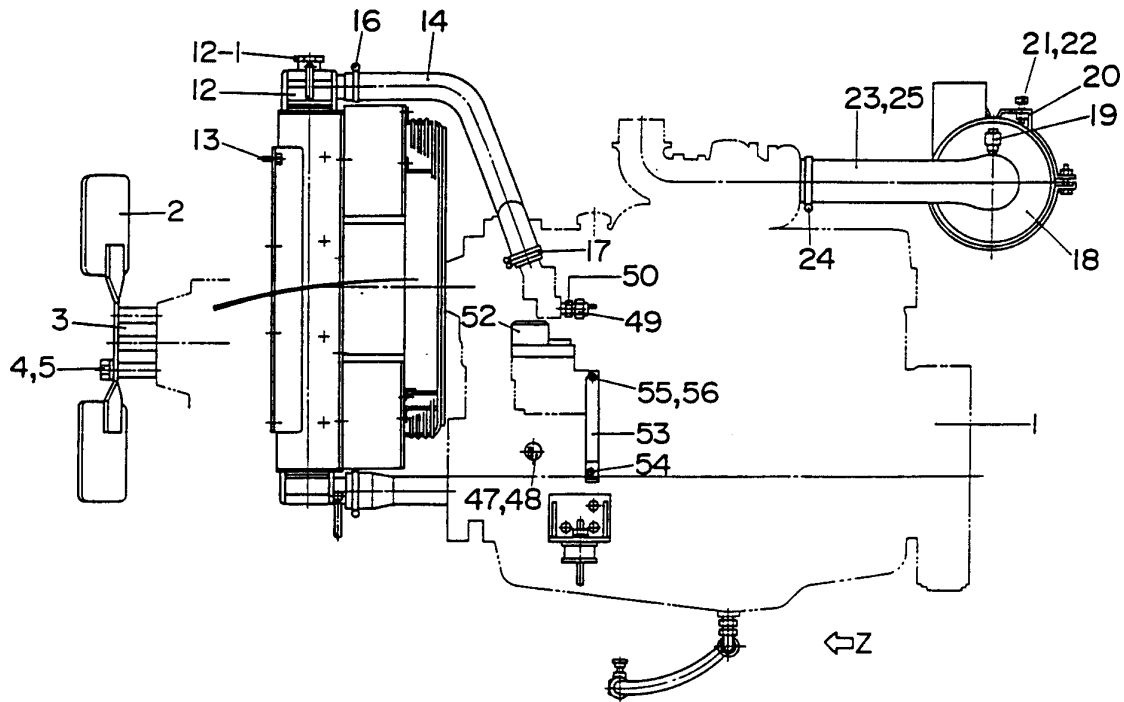
# DCA-125SSJU ENGINE AND RADIATOR ASSY.

ENGINE AND RADIATOR ASSY.S/N7500562~

<u>NO.</u>	<u>PART NO.</u>	<u>PART NAME</u>	<u>QTY.</u>	<u>REMARKS</u>
40	0605515146	HOSE BAND	1	
41	0605515200	HOSE BAND	1	
42	0602022563	ADAPTER .....	1	10M18 X 1.5F80XS
43	0602022561	90° ELBOW .....	1	3398210-10+
44	0603306590	CONNECTOR .....	1	10WFTXS
45	0603300285	ROCKNUT .....	1	10WLN
46	0605511395	VALVE .....	1	XV500P8
47	0603306395	HOSE JOINT .....	1	30182810
48	0602021070	CAP .....	1	10FNTXS
49	0269200406	DRAIN HOSE .....	1	83610
50	M9300000203	RESERVE TANK	1	
51	06020100900	CAP, RESERVE TANK	1	
52	M3316100104	BRACKET, RESERVE TANK	1	
53	0110080020	HEX. HEAD BOLT .....	2	REPLACES 0016908020
54	0193601080	HOSE	1	
55	M2260600024	RELAY BRACKET	1	
56	0602202592	RELAY .....	1	AT141011
57	0017106015	HEX. HEAD BOLT	2	
58	M3313100004	RADIATOR COVER	1	
59	0110080020	HEX. HEAD BOLT .....	4	REPLACES 0016908020
60	0043006000	LOCK WASHER	8	
61	0110080020	HEX. HEAD BOLT .....	1	REPLACES 0016908020
62	0602122281	OIL SWITCH .....	1	1718939011
63	0602123282	WATER SWITCH .....	1	1518183041
64	M9200100404	ADAPTER	1	
65	M9200100704	ADAPTER	1	
66	0602014299	WATER HEATER KIT .....	1	RE42138
67	DYNC70025000012	ACTUATOR .....	1	REPLACES 0602150093
68	M3356200004	STOPPER BRACKET	1	
69	0016910015	HEX. HEAD BOLT	1	
70	0016906020	HEX. HEAD BOLT	1	
71	0207006000	HEX. NUT	1	

# DCA-125SSJU ENGINE AND RADIATOR ASSY.

ENGINE AND RADIATOR ASSY. S/N7500283 TO S/N7500561



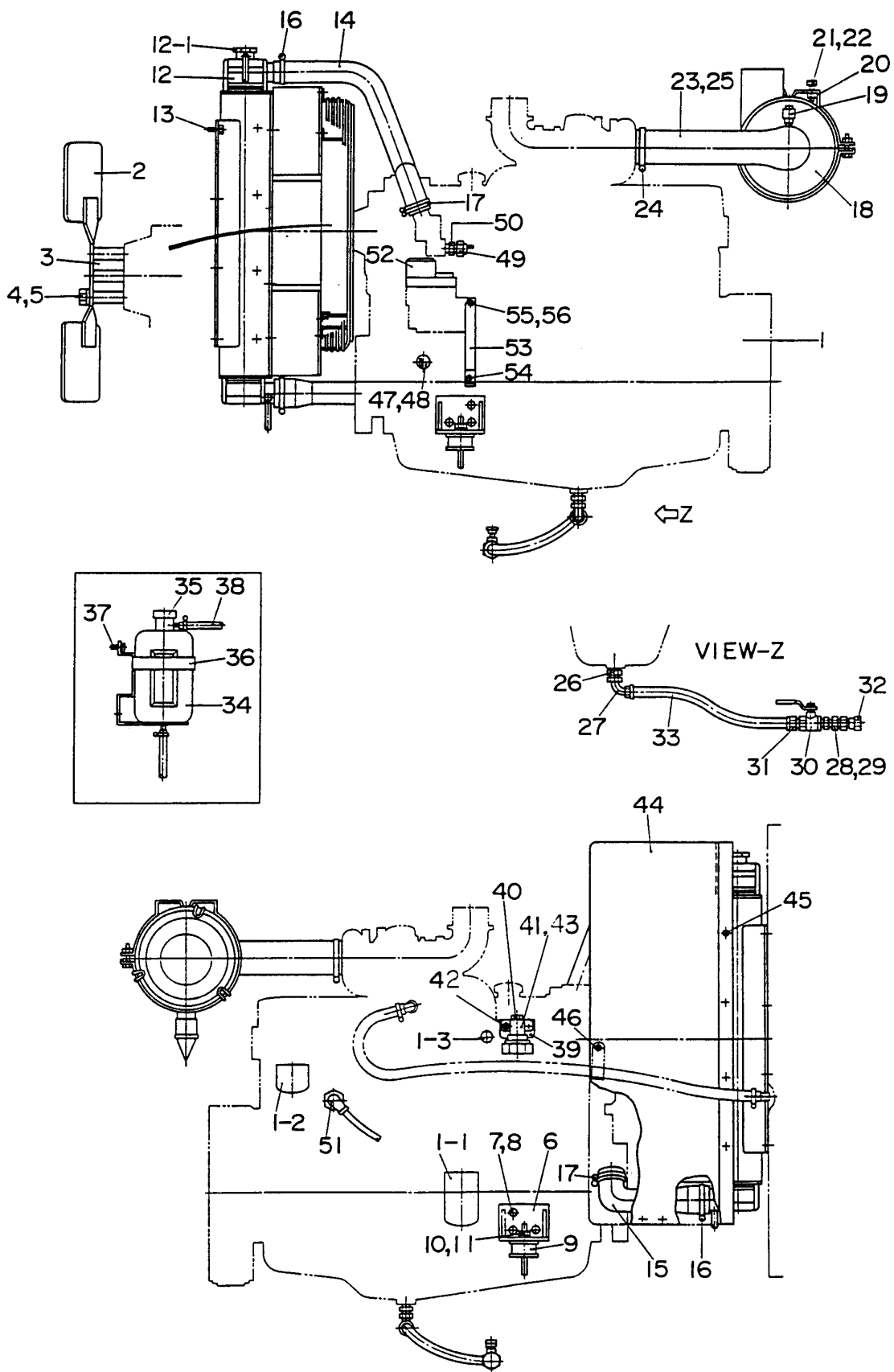
# DCA-125SSJU ENGINE AND RADIATOR ASSY.

ENGINE AND RADIATOR ASSY. S/N7500283 TO S/N7500561

<u>NO.</u>	<u>PART NO.</u>	<u>PART NAME</u>	<u>QTY.</u>	<u>REMARKS</u>
1	M3923200004	ENGINE .....	1	JOHN DEERE 6068TF
	0602011491	FAN BELT	1	
1-1	0602041290	ELEMENT, OIL FILTER .....	1	RE59754A
1-2	0602042590	ELEMENT, FUEL FILTER .....	1	RE62418
1-3	0602014287	ELECTRIC HEATER .....	1	RE502668
2	0602060010	BLOWER FAN .....	1	422198
3	0602061000	FAN SPACER .....	1	R81911
4	0012110095	HEX. HEAD BOLT	4	
5	030210250	LOCK WASHER .....	4	REPLACES 0042510000
6	M2303200303	ENGINE FOOT	2	
7	0131151240	HEX HEAD BOLT .....	6	REPLACES 0010312030
8	0040012000	LOCK WASHER	6	
9	0605000060	RUBBER SUSPENSION	2	
10	0030012000	HEX. NUT	2	
11	0040012000	LOCK WASHER	2	
12	0602012723	RADIATOR .....	1	C2810060000
12-1	0602011066	CAP .....	1	C89C0225010
13	011008020	HEX. HEAD BOLT .....	8	REPLACES 0016908020
14	M3310500403	RADIATOR HOSE	1	
15	M3310500503	RADIATOR HOSE	1	
16	0605515148	HOSE BAND	2	
17	0605515147	HOSE BAND	2	
18	0602046258	AIR CLEANER .....	1	FRG100297
	0602046377	ELEMENT, AIR CLEANER .....	1	P778214
19	0602040650	INDICATOR, AIR CLEANER .....	1	RBX002252
20	0602040596	BAND, AIR CLEANER .....	2	P004076
21	0110080020	HEX. HEAD BOLT .....	4	REPLACES 0016908020
22	0207008000	HEX. NUT	4	
23	M3373100003	HOSE, AIR CLEANER	1	
24	0605515146	HOSE BAND	1	
25	0605515200	HOSE BAND	1	
26	0602022563	ADAPTER .....	1	10M18X1.5 F80XS
27	0602022561	90° ELBOW	1	
28	0603306590	CONNECTOR	1	
29	0603300285	ROCKNUT	1	
30	0605511395	VALVE .....	1	XV500P8
31	0603306395	HOSE JOINT	1	
32	0602021070	CAP	1	
33	0269200406	DRAIN HOSE	1	
34	M9300000203	RESERVE TANK	1	
35	0802010900	CAP, RESERVE TANK .....	1	REPLACES 0602010900
36	M3316100104	BRACKET, RESERVE TANK	1	
37	0110080020	HEX. HEAD BOLT .....	2	REPLACES 0016908020
38	0193601080	HOSE	1	
39	M226060024	RELAY BRACKET	1	

# DCA-125SSJU ENGINE AND RADIATOR ASSY.

ENGINE AND RADIATOR ASSY. S/N7500283 TO S/N7500561



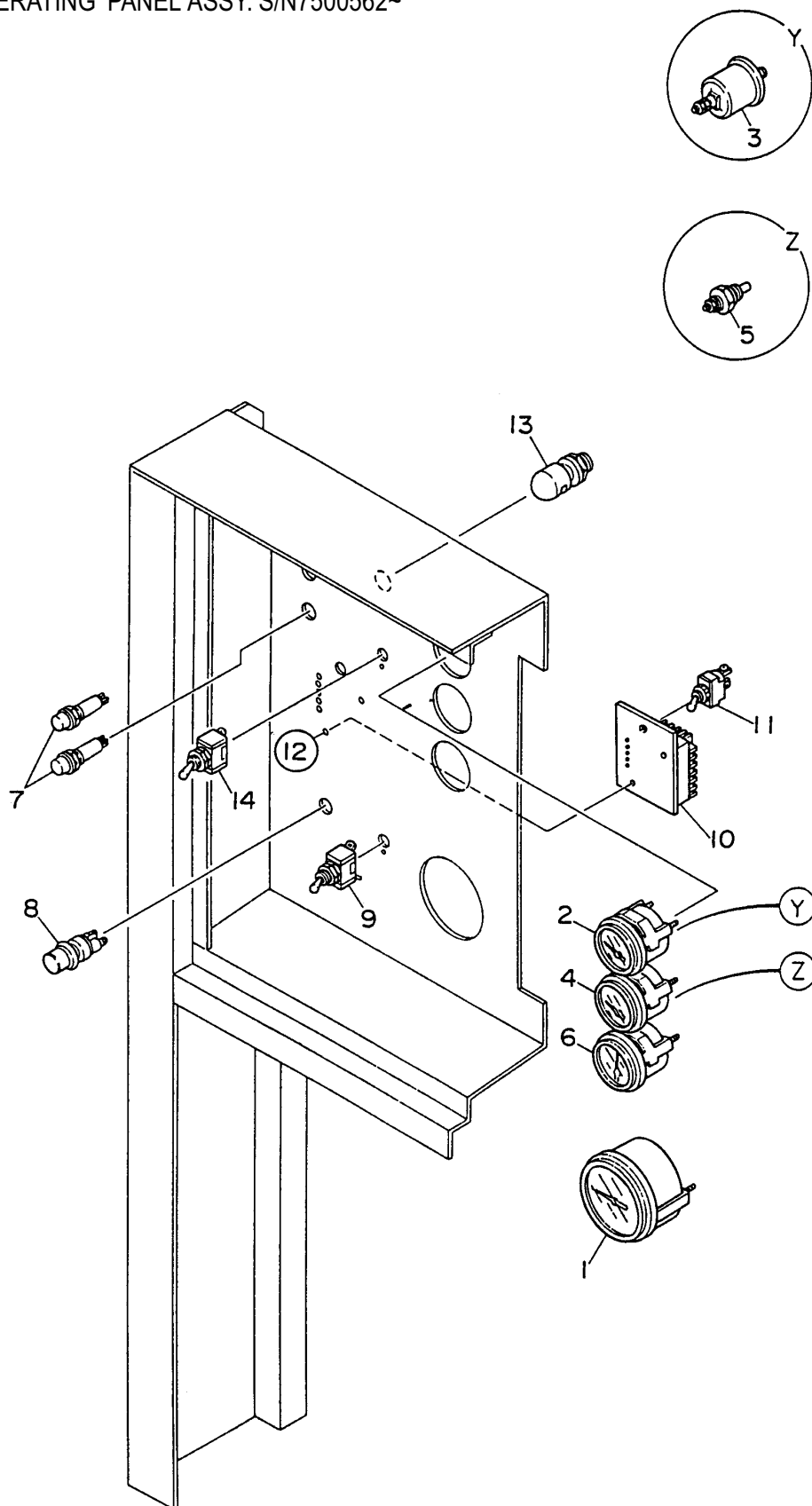
# DCA-125SSJU ENGINE AND RADIATOR ASSY.

ENGINE AND RADIATOR ASSY. S/N75000283 TO S/N7500561

<u>NO.</u>	<u>PART NO.</u>	<u>PART NAME</u>	<u>QTY.</u>	<u>REMARKS</u>
40	0017410020	HEX. HEAD BOLT	1	
41	0602202592	RELAY .....	1	..... AT141011
42	0027106015	MACHINE SCREW	2	
43	0030006000	HEX. NUT	2	
44	M3312600004	RADIATOR COVER	1	
45	0016908020	HEX. HEAD BOLT	4	
46	0016908020	HEX. HEAD BOLT	1	
47	0602122281	OIL SWITCH .....	1	..... 1718939011
48	M9200100704	ADAPTER	1	
49	0602123282	WATER SWITCH .....	1	..... 1518183041
50	M9200100404	ADAPTER	1	
51	0602014299	WATER HEATER KIT .....	1	..... RE42138
52	DYNC70025000012	ACTUATOR .....	1	..... REPLACES 0602150093
53	M3356200004	STOPPER BRACKET	1	
54	0017110020	HEX. HEAD BOLT	1	
55	0017106020	HEX. HEAD BOLT	1	
56	0207006000	HEX. NUT	1	

# DCA-125SSJU ENGINE OPERATING PANEL ASSY.

ENGINE OPERATING PANEL ASSY. S/N7500562~



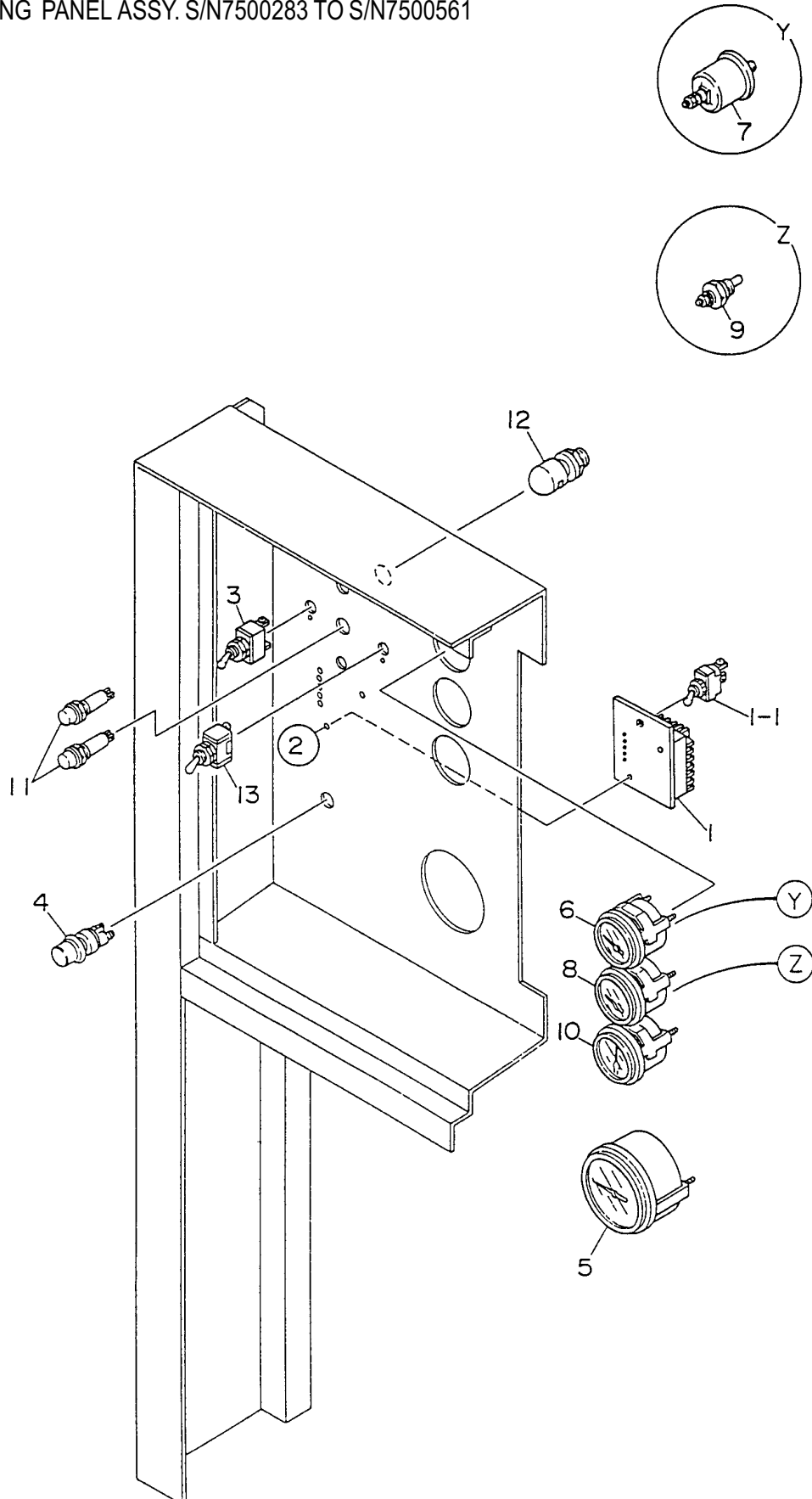
# DCA-125SSJU ENGINE OPERATING PANEL ASSY.

ENGINE OPERATING PANEL ASSY. S/N7500562~

<u>NO.</u>	<u>PART NO.</u>	<u>PART NAME</u>	<u>QTY.</u>	<u>REMARKS</u>
	M3359200012	WIRE HARNESS, ENGINE	1	
	M3359200113	WIRE HARNESS, ENGINE	1	
	0601802132	FUSE .....	2	10A
1	0602120096	TACHOMETER .....	1	103678
2	0602122093	OIL PRESSURE GAUGE .....	1	100174
3	0602122272	UNIT, OIL PRESSURE .....	1	108497
4	0602123092	WATER TEMPERATURE GAUGE .....	1	100182
5	0602123261	UNIT, WATER TEMPERATURE .....	1	0202500
6	0602121080	CHARGING AMMETER .....	1	100158
7	0602103092	ALARM LAMP .....	2	PL-05
8	0601831585	PREHEAT BUTTON .....	1	44047
	0601831586	CAP .....	1	44053
9	0601831395	ENGINE SPEED SWITCH .....	1	7302K36
10	ECU9988N	ENGINE CONTROLLER .....	1	REPLACES 0602202545
11	82608	SWITCH .....	1	REPLACES 0601831340
12	0027104035	MACHINE SCREW	2	
	0030000400	HEX. NUT .....	2	REPLACES 0207004000
13	0601810141	PANEL LIGHT .....	1	9826800370
14	0601831330	SWITCH, PANEL LIGHT .....	1	900001

# DCA-125SSJU ENGINE OPERATING PANEL ASSY.

ENGINE OPERATING PANEL ASSY. S/N7500283 TO S/N7500561



# DCA-125SSJU ENGINE OPERATING PANEL ASSY.

ENGINE OPERATING PANEL ASSY. S/N7500283 TO S/N7500561

<u>NO.</u>	<u>PART NO.</u>	<u>PART NAME</u>	<u>QTY.</u>	<u>REMARKS</u>
	M3359200002	WIRE HARNESS	1	
	M3359200103	WIRE HARNESS	1	
	M3359200203	WIRE HARNESS	1	
	0601802132	FUSE .....	2	10A
1	ECU88N	ENGINE CONTROLLER .....	1	REPLACES 0601827395
1-1	7562K4	SWITCH .....	1	REPLACES 0601831340
	0600500091	NAME PLATE	1	
2	0027104035	MACHINE SCREW	2	
	0030000400	HEX. NUT	2	REPLACES 0207004000
3	0601831390	ENGINE SPEED SWITCH .....	1	MS90311231
4	0601831594	PREHEAT BUTTON .....	1	S/N7500283 TO S/N7500342; R39554
	0601831585	PREHEAT BUTTON .....	1	S/N7500343~; 44047
	0601831584	CAP .....	1	S/N7500283 TO S/N7200342; T55585
	0601831586	CAP .....	1	S/N7500343~;44053
5	0602120096	TACHOMETER .....	1	103678
6	0602122093	OIL PRESSURE GAUGE .....	1	100174
7	0602122272	UNIT, OIL PRESSURE .....	1	100174
8	0602123092	WATER TEMPERATURE GAUGE .....	1	100182
9	0602123261	UNIT, WATER TEMPERATURE .....	1	0202500
10	0602121080	CHARGING AMMETER .....	1	100158
11	0602103092	ALARM LAMP .....	2	PL05
	0601810245	BULB .....	2	E10T10 DC18V
12	0601810141	PANEL LIGHT .....	1	9826800370
13	0601831330	SWITCH, PANEL LIGHT .....	1	900001



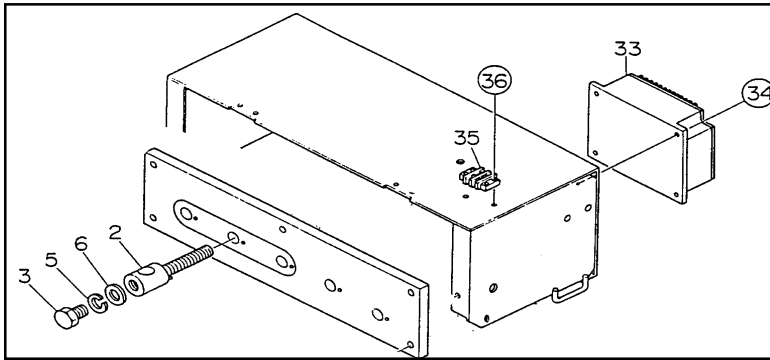
# DCA-125SSJU OUTPUT TERMINAL ASSY.

## OUTPUT TERMINAL ASSY.

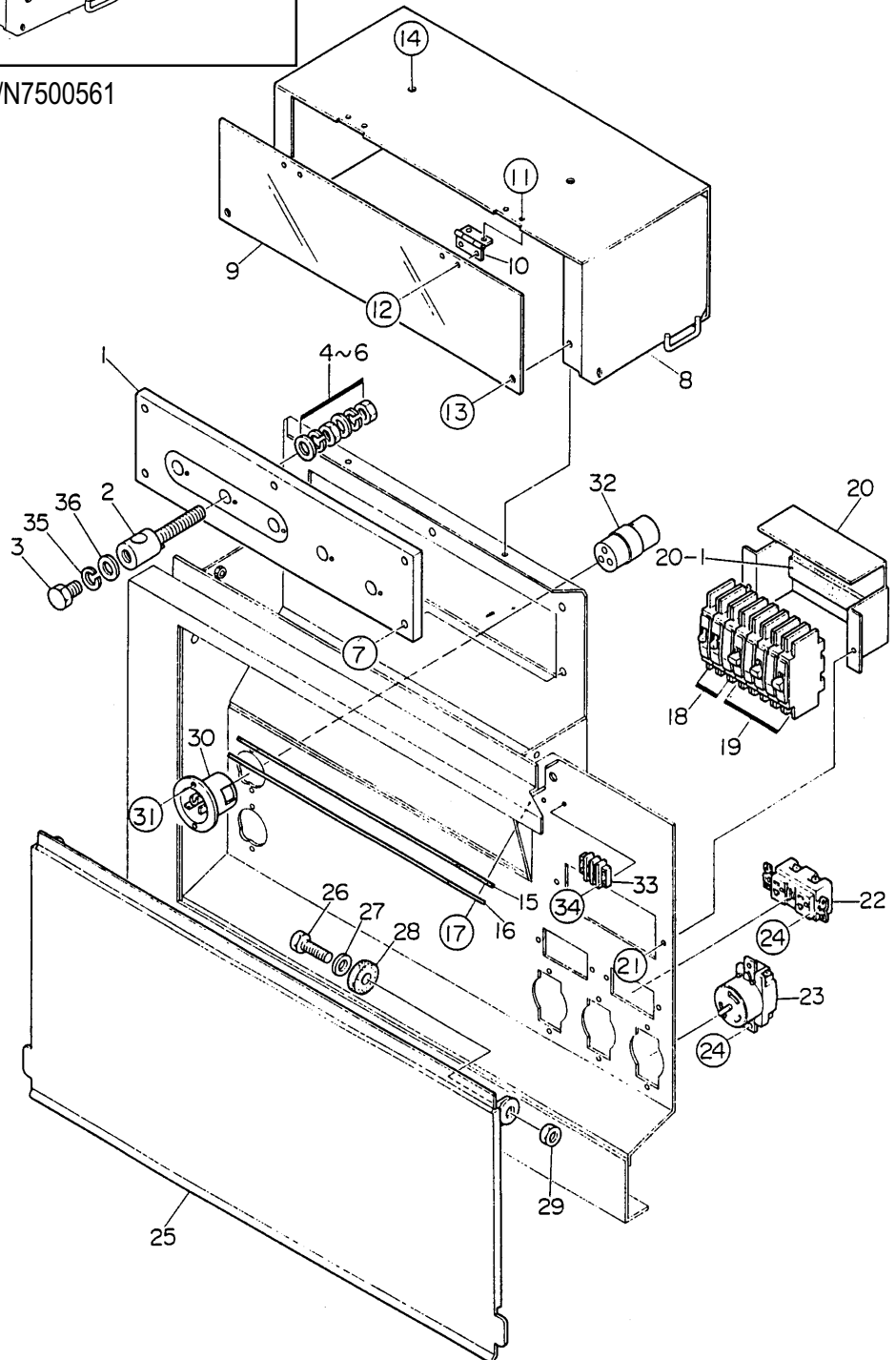
<u>NO.</u>	<u>PART NO.</u>	<u>PART NAME</u>	<u>QTY.</u>	<u>REMARKS</u>
1	M3230700003	TERMINAL PANEL	1	
2	M3278500004	OUTPUT TERMINAL BOLT .....	5	S/N7500562~
	M9220100304	OUTPUT TERMINAL BOLT .....	5	S/N7500283 TO S/N7500561
3	0801830904	TIE BOLT .....	5	S/N7500562~
	M9220100404	TIE BOLT .....	5	S/N7500283 TO S/N7500561
4	0039316000	HEX. NUT	10	
5	0040016000	LOCK WASHER	10	
6	0041416000	PLAIN WASHER	15	
7	0012108035	HEX. HEAD BOLT .....	5	REPLACES 0016908035
8	M3238100103	TERMINAL COVER .....	1	S/N7500562~
	M3238100013	TERMINAL COVER .....	1	S/N7500283 TO S/N7500561
9	M3236100104	OUTPUT WINDOW	1	
10	0605010040	HINGE	2	
11	0027103010	MACHINE SCREW	4	
	0207003000	HEX. NUT .....	4	REPLACES 0030003000
	S8413	PLAIN WASHER .....	4	REPLACES 0041203000
12	0027103010	MACHINE SCREW	4	
	0207003000	HEX. NUT .....	4	REPLACES 0030003000
13	011206020	HEX. HEAD BOLT .....	2	REPLACES 0016906020
14	011206020	HEX. HEAD BOLT .....	4	REPLACES 0016906020
15	M3236400004	CABLE OUTLET COVER	1	
16	M3236300004	SUPPORTER, CABLE OUTLET COVER	1	
17	011206020	HEX. HEAD BOLT .....	6	REPLACES 0016906020
18	0601808803	CIRCUIT BREAKER .....	2	Q0U 120B 1P 20A
19	0601808804	CIRCUIT BREAKER .....	3	Q0U 250B 2P 50A
20	M1260700304	BREAKER FITTING COVER	1	
20-1	0222100150	CUSHION RUBBER	1	
21	011206020	HEX. HEAD BOLT .....	2	REPLACES 0016906020
22	0601812597	RECEPTACLE .....	2	S/N7500562~; GF530EM125V20AX2; REPLACES 0601812598
	0601812598	RECEPTACLE .....	2	S/N7500283 TO S/N7500561; GF530EM 125V 20AX2
23	0601811034	RECEPTACLE .....	3	S/N7500562~; CS6369 250V 50A; REPLACES 0601812538
	0601812538	RECEPTACLE .....	3	S/N7500283 TO S/N7500561; CS6369 250V 50A
24	0021304015	MACHINE SCREW .....	10	REPLACES 0027104015
	0030004000	HEX. NUT .....	10	REPLACES 0207004000
25	M3236100213	TERMINAL COVER	1	
26	012212045	HEX. HEAD BOLT .....	2	REPLACES 0010112045
27	031112230	PLAIN WASHER .....	2	REPLACES 0041212000
28	M9310200004	STAY RUBBER	2	
29	0030012000	HEX. NUT	2	

# DCA-125SSJU OUTPUT TERMINAL ASSY.

## OUTPUT TERMINAL ASSY.



S/N7500283 TO S/N7500561



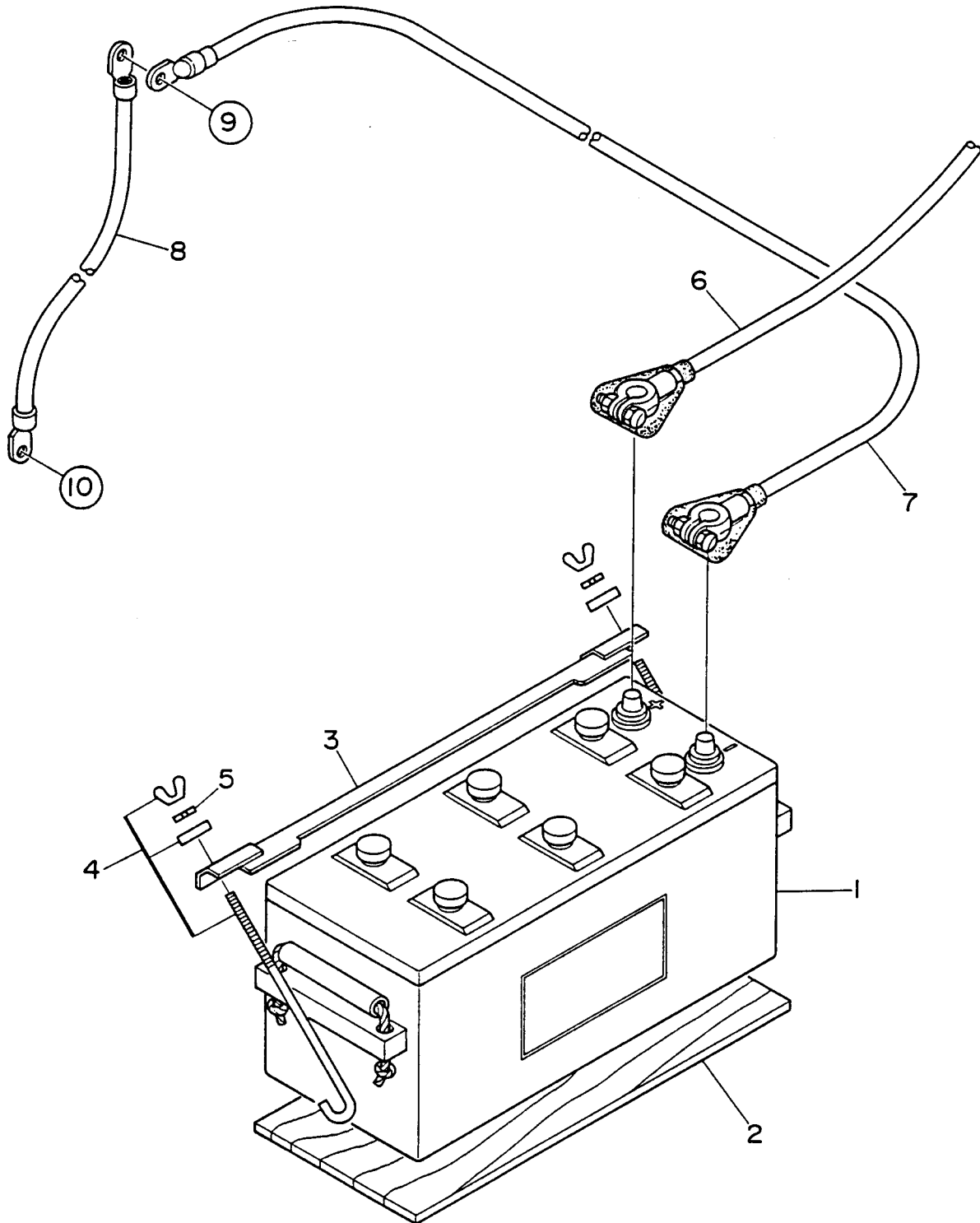
# DCA-125SSJU OUTPUT TERMINAL ASSY.

OUTPUT TERMINAL ASSY.

<u>NO.</u>	<u>PART NO.</u>	<u>PART NAME</u>	<u>QTY.</u>	<u>REMARKS</u>
30	0601811189	RECEPTACLE .....	2 .....	HBL5378C 125N 20A
31	0021304015	MACHINE SCREW .....	4 .....	REPLACES 0027104015
	0207004000	HEX.NUT .....	4 .....	S/N7500283 TO S/N7500561
32	0601812527	CONNECTOR .....	1 .....	HBL5269C 125V 15A
33	0601815194	TERMINAL .....	1 .....	S/N7500562~;601GP02
33	0602202599	CONTROLLER.....	1 .....	S/N7500283 TO S/N7500561; DYN110794000012
34	0021304015	MACHINE SCREW .....	2 .....	S/N7500562~;REPLACES 0027104015
	0027105015	MACHINE SCREW .....	4 .....	S/N7500283 TO S/N7500561
	0207005000	HEX. NUT .....	4 .....	S/N7500283 TO S/N7500561
35	030220510	LOCK WASHER .....	5 .....	S/N7500562~;REPLACES 0040020000
35	0601815194	TERMINAL .....	1 .....	S/N7500283 TO S/N7500561;601GP02
36	0041420000	PLAIN WASHER .....	5 .....	S/N7500562~
36	0027104015	MACHINE SCREW .....	2 .....	S/N7500283 TO S/N7500561
	0207004000	HEX. NUT .....	2 .....	S/N7500283 TO S/N7500561

# DCA-125SSJU BATTERY ASSY.

BATTERY ASSY.



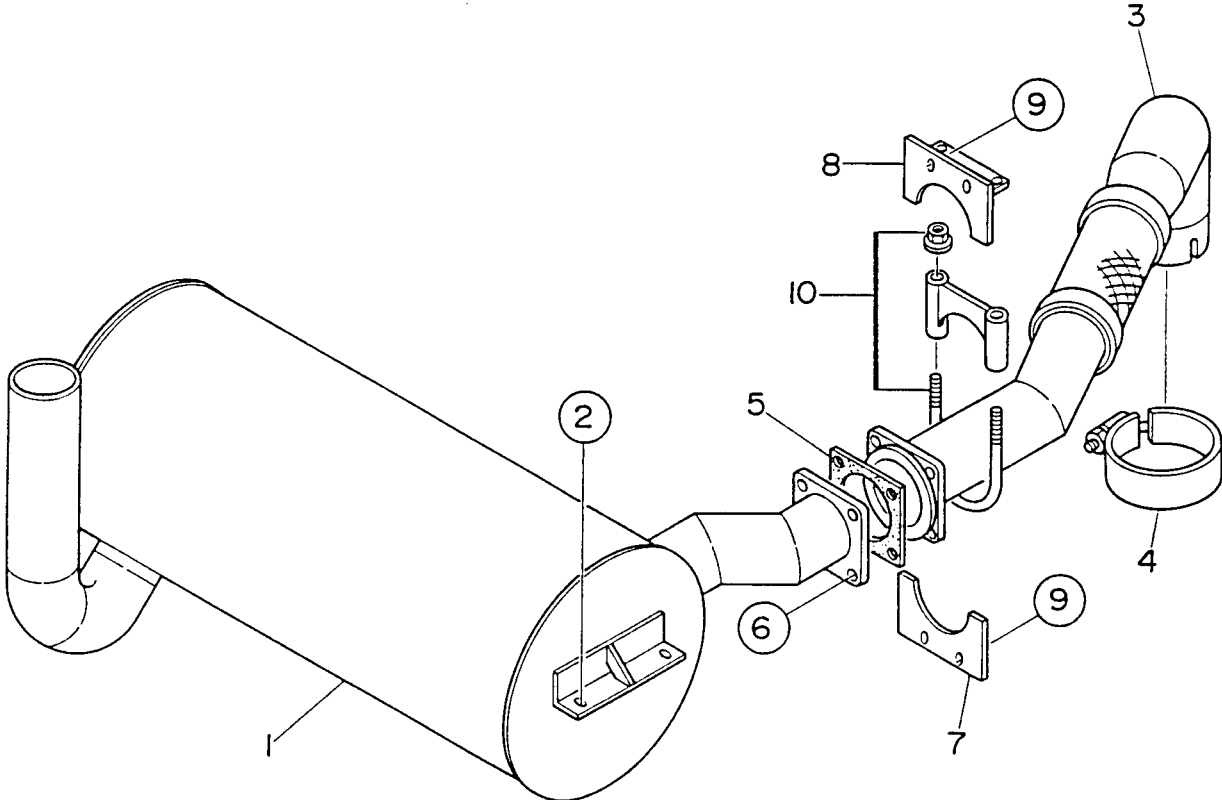
# DCA-125SSJU BATTERY ASSY.

## BATTERY ASSY.

<u>NO.</u>	<u>PART NO.</u>	<u>PART NAME</u>	<u>QTY.</u>	<u>REMARKS</u>
1	0602220196	BATTERY .....	1 .....	4D-2
2	M9310500404	BATTERY SHEET	1	
3	M9103000504	BATTERY BAND	1	
4	0602220921	BATTERY BOLT SET .....	2 .....	BHB-12J 1/4-L12
5	0040006000	LOCK WASHER	2	
6	M3346900004	BATTERY CABLE	1	
7	M3346900104	BATTERY CABLE	1	
8		CABLE	1	
9	0017112025	HEX. HEAD BOLT	1	
	0040512000	TOOTHED WASHER	1	
10	012210020	HEX. HEAD BOLT .....	1 .....	REPLACES 0017110020
	0040510000	TOOTHED WASHER	1	

**DCA-125SSJU MUFFLER ASSY.**

MUFFLER ASSY.



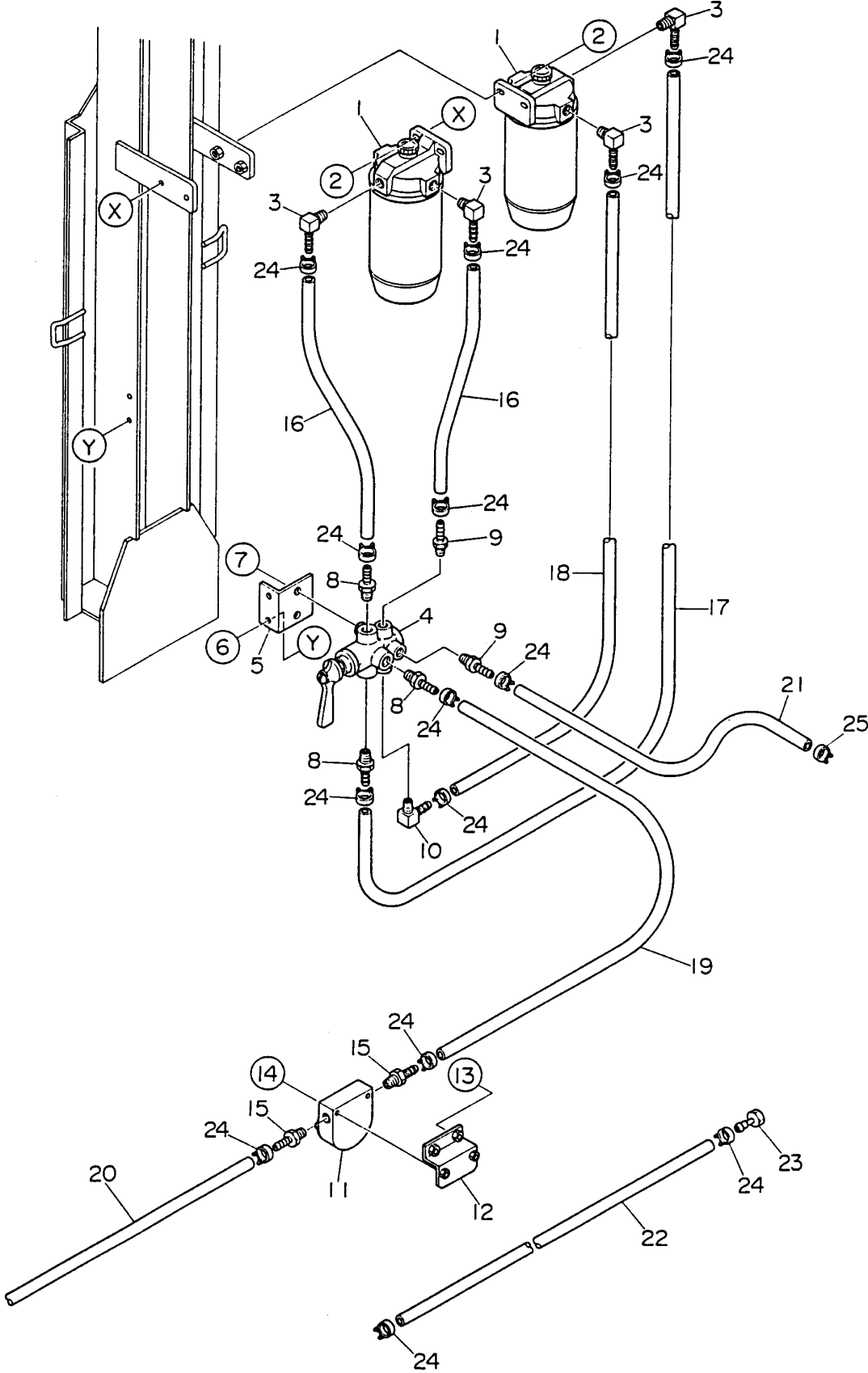
## DCA-125SSJU MUFFLER ASSY.

### MUFFLER ASSY.

<u>NO.</u>	<u>PART NO.</u>	<u>PART NAME</u>	<u>QTY.</u>	<u>REMARKS</u>
1	0602300167	MUFFLER .....	1 .....	27299N
2	012210025	HEX. HEAD BOLT .....	4 .....	REPLACES 0016910025
3	M3333000303	EXHAUST PIPE	1	
4	0602325066	CLAMP	1	
5	M3333200004	GASKET	1	
6	014210040	HEX. HEAD BOLT .....	4 .....	REPLACES 0017110040
7	M33330400304	COVER	1	
8	M3330400403	BRACKET	1	
9	011008020	HEX. HEAD BOLT .....	4 .....	REPLACES 0016908020

# DCA-125SSJU FUEL-WATER SEPARATOR ASSY.

FUEL-WATER SEPARATOR ASSY.S/N7500562~



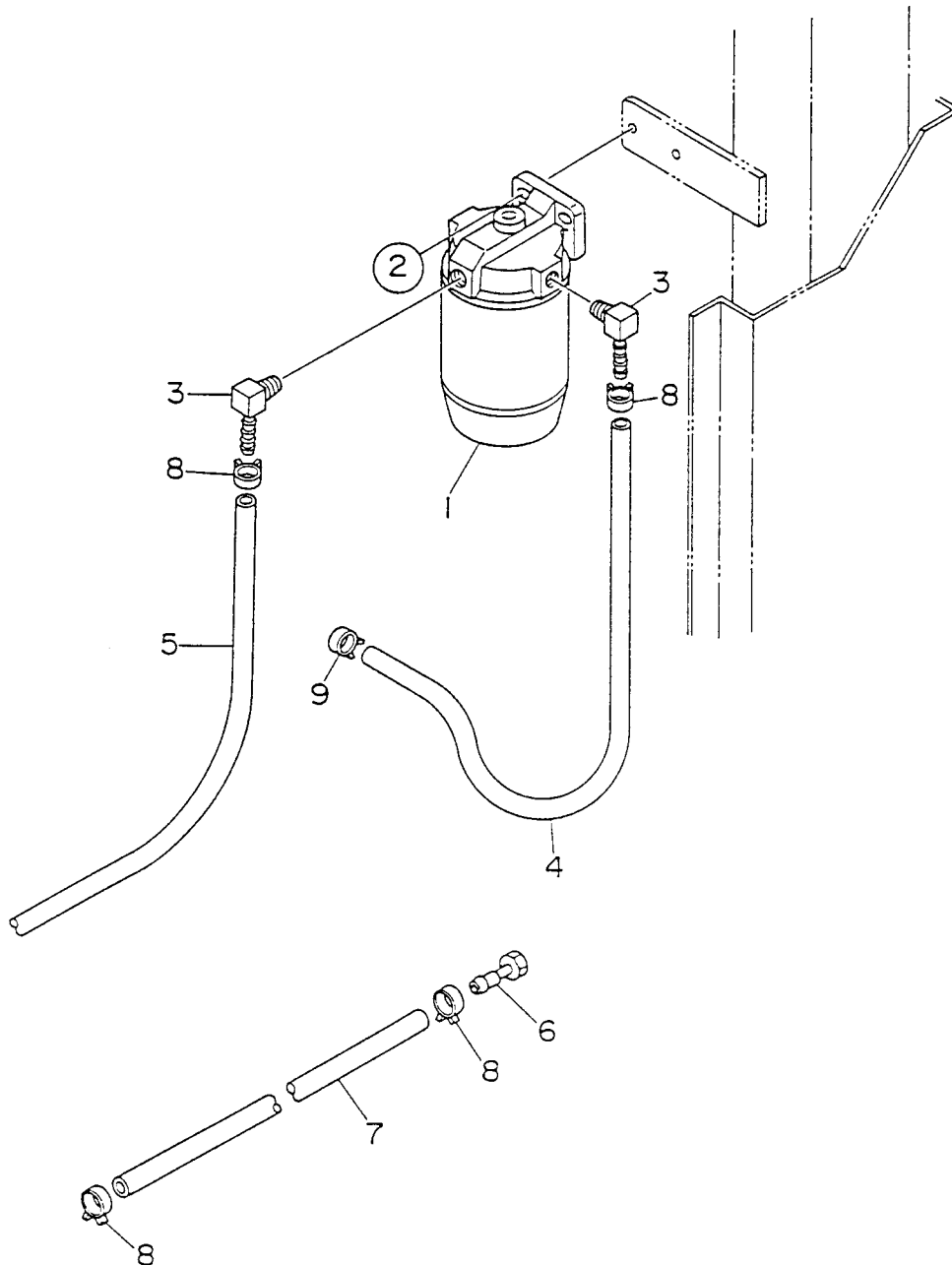
# DCA-125SSJU FUEL-WATER SEPARATOR ASSY.

FUEL-WATER SEPARATOR ASSY.S/N7500562~

<u>NO.</u>	<u>PART NO.</u>	<u>PART NAME</u>	<u>QTY.</u>	<u>REMARKS</u>
1	245R30	FUEL WATER SEPARATOR ASSY. ....	2	REPLACES 0602042273
2	0016908030	HEX. HEAD BOLT	4	
3	0602022784	ELBOW JOINT	4	
4	0605511396	VALVE .....	1	SK1031
5	M3435400004	VALVE BRACKET	1	
6	0016908020	HEX. HEAD BOLT	2	
7	0643004060	HEX. HEAD BOLT	2	
	004300400	LOCK WASHER	2	
	0043104000	PLAIN WASHER	2	
8	0602022776	HOSE JOINT	3	
9	0602022778	HOSE JOINT	2	
10	0602022774	ELBOW JOINT	1	
11	LGX200	FUEL FILTER .....	1	REPLACES 0602042492
12	M3368700004	FILTER BRACKET	1	
13	0016906020	HEX. HEAD BOLT	2	
14	0027104035	MACHINE SCREW	2	
15	0602022779	HOSE JOINT	2	
16	0191300420	FILTER HOSE	2	
17	0191300650	FILTER HOSE	1	
18	0191300510	FILTER HOSE	1	
19	0191300900	SUCTION HOSE	1	
20	0191302150	SUCTION HOSE	1	
21	0191300600	SUCTION HOSE	1	
22	0191303350	RETURN HOSE	1	
23	0602042601	RETURN PIPE .....	1	JOHN DEERE RE67050
24	0605515109	HOSE BAND	15	
25	0605515189	HOSE BAND	1	

# DCA-125SSJU FUEL-WATER SEPARATOR ASSY.

FUEL-WATER SEPARATOR ASSY.S/N7500283 TO S/N7500561



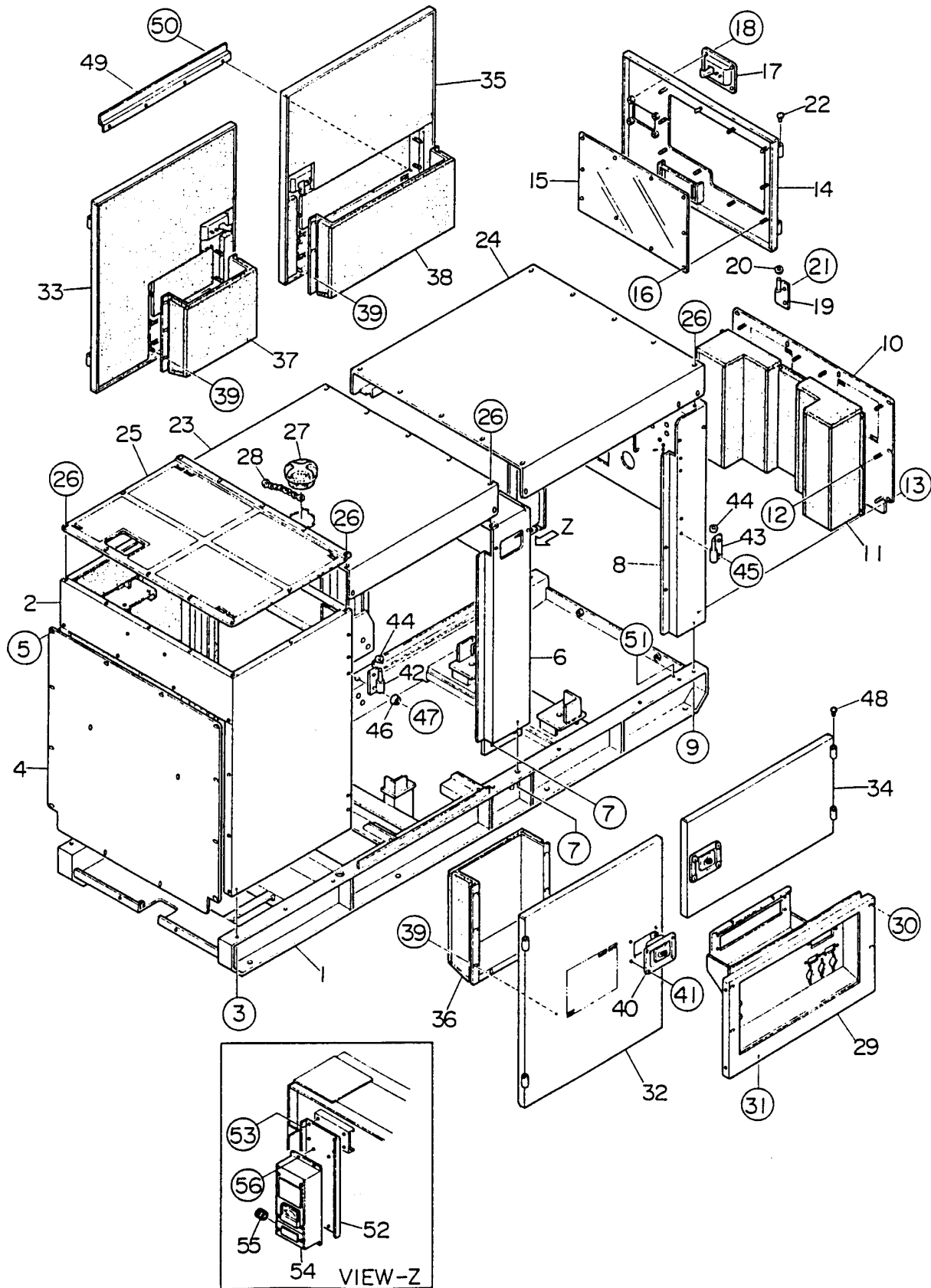
# DCA-125SSJU FUEL-WATER SEPARATOR ASSY.

FUEL-WATER SEPARATOR ASSY.S/N7500283 TO S/N7500561

<u>NO.</u>	<u>PART NO.</u>	<u>PART NAME</u>	<u>QTY.</u>	<u>REMARKS</u>
1	0602042284	WATER SEPARATOR .....	1 .....	215R
	0602042285	ELEMENT, WATER SEPARATOR .....	1 .....	
2	0016906030	HEX. HEAD BOLT .....	2 .....	
3	0602022784	ELBOW JOINT .....	2 .....	
4	0191300380	SUCTION HOSE .....	1 .....	
5	0191303350	SUCTION HOSE .....	1 .....	
6	0602042601	RETURN PIPE .....	1 .....	RE67050
7	0191303350	RETURN PIPE .....	1 .....	
8	0605515109	HOSE BAND .....	5 .....	RS8010
9	0605515189	HOSE BAND .....	1 .....	91004

# DCA-125SSJU ENCLOSURE ASSY.

ENCLOSURE ASSY.



# DCA-125SSJU ENCLOSURE ASSY.

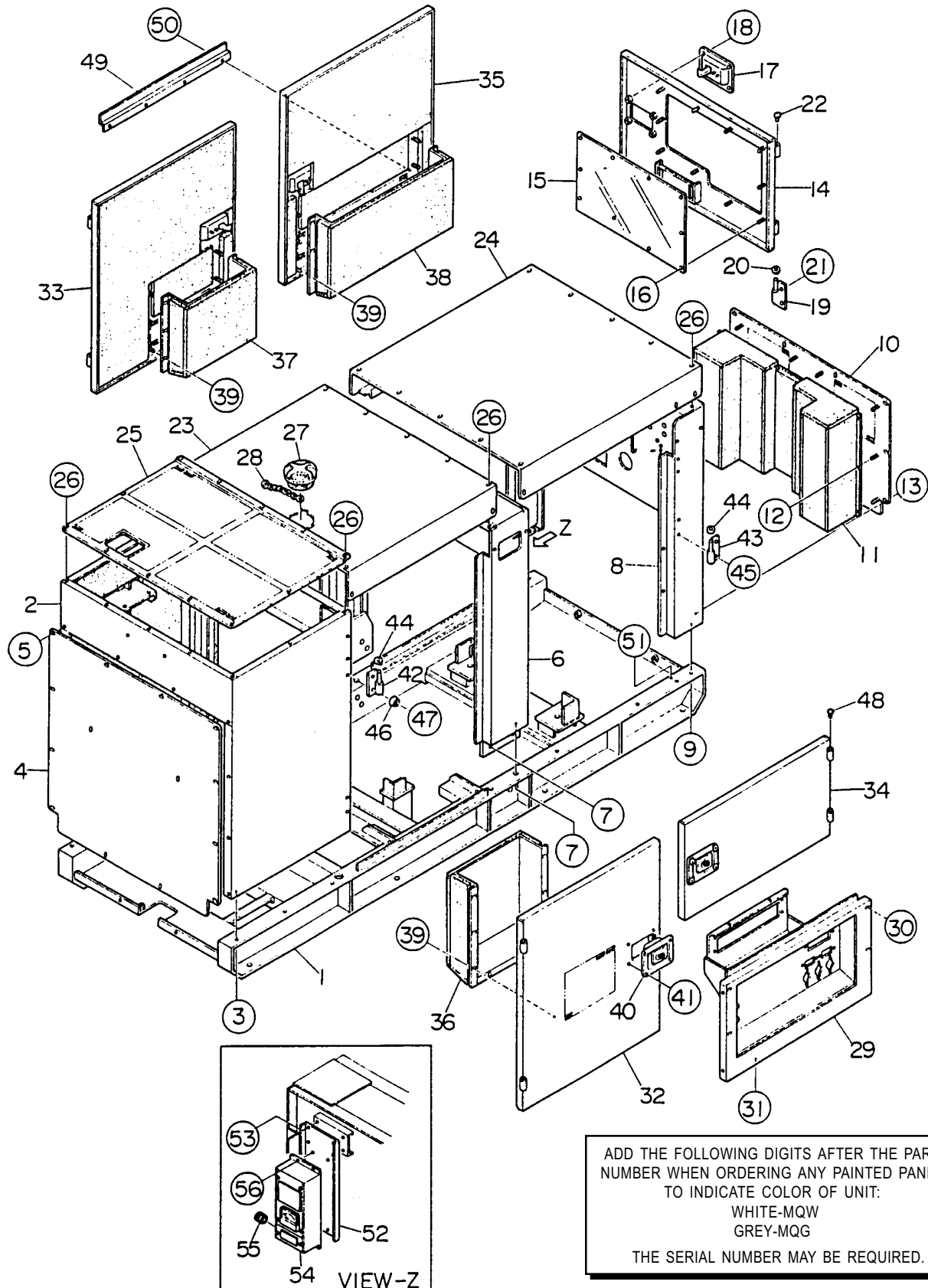
## ENCLOSURE ASSY.

<u>NO.</u>	<u>PART NO.</u>	<u>PART NAME</u>	<u>QTY.</u>	<u>REMARKS</u>
1	M3415000212	BASE .....	1	S/N7500308~
	M3415000202	BASE .....	1	S/N7500283 TO S/N7500307
2	M3423000602	FRONT FRAME .....	1	S/N7500308~
	M3495100503	ACOUSTIC SHEET .....	1	S/N7500308~
	M3423000302	FRONT FRAME .....	1	S/N7500283 TO S/N7500307
	M3493100203	ACOUSTIC SHEET .....	1	S/N7500283 TO S/N7500307
3	012210025	HEX. HEAD BOLT .....	6	REPLACES 0016910025
4	M3425200204	COVER, FRONT FRAME	1	
	M3493100304	ACOUSTIC SHEET	1	
5	011008020	HEX. HEAD BOLT .....	14	REPLACES 0016908020
6	M3435000123	CENTER FRAME .....	1	S/N7500562~
	M3495000113	CENTER FRAME .....	1	S/N7500283 TO S/N7500561
	M3493200004	ACOUSTIC SHEET	1	
7	0010114040	HEX. HEAD BOLT	12	
	00300140000	HEX. NUT	12	
	00400140000	LOCK WASHER	24	
	031114260	PLAIN WASHER .....	24	REPLACES 0041214000
8	M3445000022	REAR FRAME .....	1	S/N7500562~
	M3445000012	REAR FRAME .....	1	S/N7500283 TO S/N7500561
	M3493300204	ACOUSTIC SHEET	1	
9	012210025	HEX. HEAD BOLT .....	4	REPLACES 0016910025
	0040510000	TOOTHED WASHER .....	1	S/N7500562~
10	M3443300203	REAR COVER	1	
11	M3443300303	DUCT, REAR COVER	1	
	M3493300303	ACOUSTIC SHEET	1	
12	0207006000	HEX. NUT	12	
13	011008020	HEX. HEAD BOLT .....	10	REPLACES 0016908020
14	M3443200113	REAR DOOR	1	
15	M3443600104	WINDOW PLATE	1	
16	020106050	HEX. NUT .....	10	REPLACES 0207306000
	952404470	PLAIN WASHER .....	10	REPLACES 0041206000
17	B9114000002	DOOR HANDLE ASSY. ....	1	REPLACES M9113000002
18	0027106016	MACHINE SCREW .....	4	REPLACES 0021806015
	020106050	HEX. NUT .....	4	REPLACES 0030006000
19	M9110100204	HINGE	2	
20	M9116100004	WASHER	2	
21	011008020	HEX. HEAD BOLT .....	3	REPLACES 0016908020
22	0845031504	BLIND PLUG .....	2	REPLACES M9310000004
23	M3463100203	ROOF PANEL	1	
	M3493500203	ACOUSTIC SHEET	1	
24	M3463200102	ROOF PANEL	1	
	M3493500303	ACOUSTIC SHEET	1	

ADD THE FOLLOWING DIGITS AFTER THE PART  
NUMBER WHEN ORDERING ANY PAINTED PANEL  
TO INDICATE COLOR OF UNIT:  
WHITE-MQW  
GREY-MQG  
THE SERIAL NUMBER MAY BE REQUIRED.

# DCA-125SSJU ENCLOSURE ASSY.

ENCLOSURE ASSY.



ADD THE FOLLOWING DIGITS AFTER THE PART NUMBER WHEN ORDERING ANY PAINTED PANEL TO INDICATE COLOR OF UNIT:  
WHITE-MQW  
GREY-MQG  
THE SERIAL NUMBER MAY BE REQUIRED.

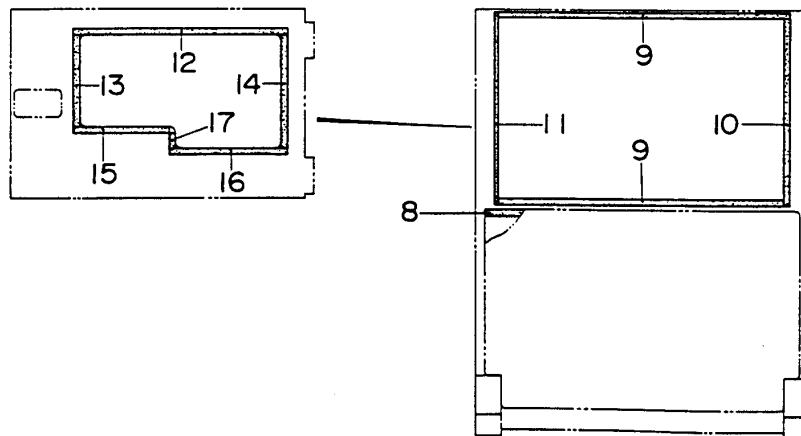
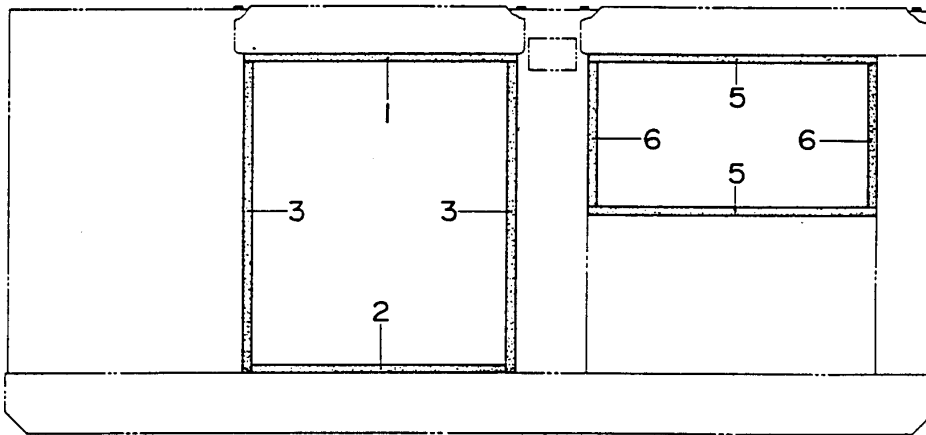
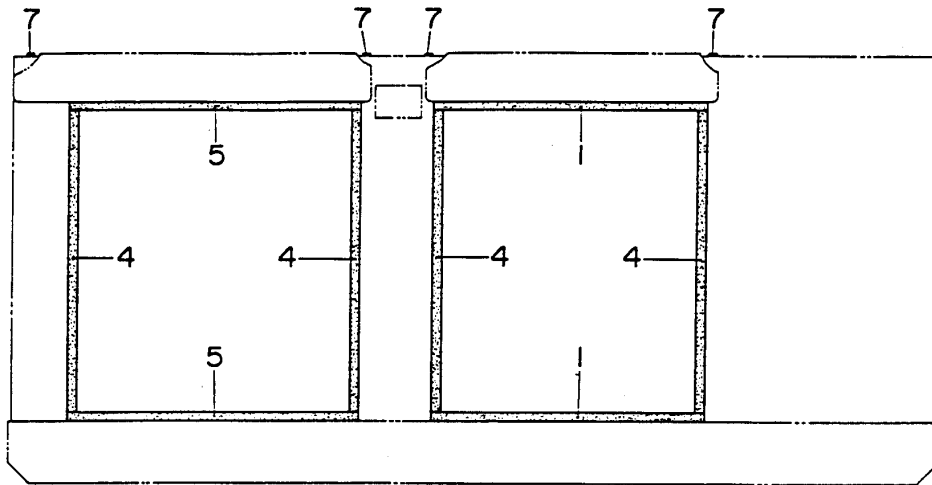
# DCA-125SSJU ENCLOSURE ASSY.

## ENCLOSURE ASSY.

<u>NO.</u>	<u>PART NO.</u>	<u>PART NAME</u>	<u>QTY.</u>	<u>REMARKS</u>
25	M3463500104	OVER COVER, FRONT FRAME	1	
26	011008020	HEX. HEAD BOLT .....	37	REPLACES 0016908020
27	1625165103	BONNET CAP .....	1	REPLACES M9310000103
28	1625165204	CHAIN ASSY. ....	1	REPLACES M1483600204
29	M3453200132	SPLASHER PANEL .....	1	S/N7500562~
	M3455200002	SPLASHER PANEL .....	1	S/N7500283 TO S/N7500561
	M3493401314	ACOUSTIC SHEET	1	
30	011208060	HEX. HEAD BOLT .....	4	REPLACES 0016908055
31	012210025	HEX. HEAD BOLT .....	2	REPLACES 0016910025
32	M3453000703	SIDE DOOR	1	
	M3493400704	ACOUSTIC KIT A.S. FRT DOOR (L)	1	
33	M3453000603	SIDE DOOR	1	
	M3493400804	ACOUSTIC KIT A.S. FRT DOOR (R)	1	
34	M3453000503	SIDE DOOR (L)	1	
	M3493401004	ACOUSTIC SHEET (L)	1	
35	M3453000403	SIDE DOOR (R)	1	
	M3493401104	ACOUSTIC KIT A.S. REAR DOOR (R)	1	
36	M3453300303	DUCT (L)	1	
	M3493400904	ACOUSTIC KIT A.S. FRONT DUCT (L)	1	
37	M3453300503	DUCT (R FRONT)	1	
	M3493401404	ACOUSTIC KIT A.S. FRONT DOOR DUCT	1	
38	M3453300203	DUCT (R)	1	
	M3493401204	ACOUSTIC KIT A.S. REAR DOOR DUCT	1	
39	0207006000	HEX. NUT	25	
40	B9114000002	DOOR HANDLE ASSY. ....	4	REPLACES M9113000002
41	0021806015	MACHINE SCREW	16	
	0060006000	HEX. NUT	16	
42	M9110100204	HINGE (L)	4	
43	M9110100304	HINGE (R)	4	
44	M9116100004	WASHER	8	
45	011008020	HEX. HEAD BOLT .....	9	REPLACES 0016908020
46	0601850097	DOOR STOPPER	8	
47	0027208025	MACHINE SCREW	8	
48	0845031504	BLIND PLUG .....	8	REPLACES M9310000004
49	M3453700004	DOOR BRACKET	1	
50	011106015	HEX. HEAD BOLT .....	4	REPLACES 0016906015
51	011008020	HEX. HEAD BOLT .....	1	REPLACES 0016908020
	0040508000	TOOTHED WASHER	1	
52	M13450000014	BRACKET, BATTERY CHARGER	1	
53	0016908025	HEX. HEAD BOLT	4	
54	LC125002	BATTERY CHARGER .....	1	REPLACES 0601823092
55	0601851795	GROMMET	1	
56	0021304015	MACHINE SCREW .....	4	REPLACES 0027104015

# DCA-125SSJU RUBBER SEAL ASSY.

RUBBER SEAL ASSY.



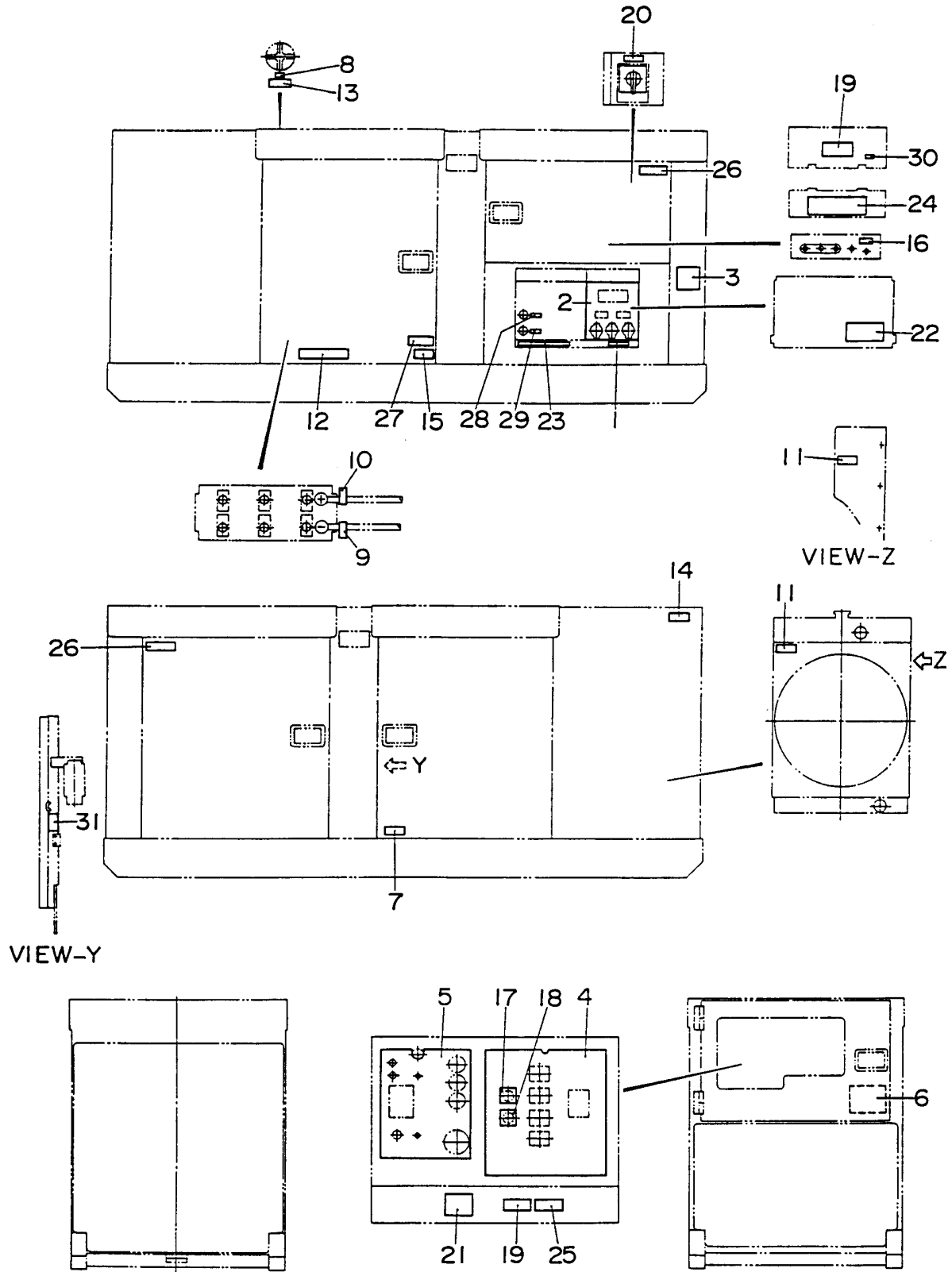
# DCA-125SSJU RUBBER SEAL ASSY.

## RUBBER SEAL ASSY.

<u>NO.</u>	<u>PART NO.</u>	<u>PART NAME</u>	<u>QTY.</u>	<u>REMARKS</u>
1	0228900890	RUBBER SEAL	3	
2	0229200810	RUBBER SEAL	1	
3	0228901020	RUBBER SEAL	2	
4	028900990	RUBBER SEAL	4	
5	0228900955	RUBBER SEAL	4	
6	0228900470	RUBBER SEAL	2	
7	0229501100	RUBBER SEAL	4	
8	0229201040	RUBBER SEAL	1	
9	0228800970	RUBBER SEAL	2	
10	0228800590	RUBBER SEAL	1	
11	0228800630	RUBBER SEAL	1	
12	0228100665	RUBBER SEAL	1	
13	0228100300	RUBBER SEAL	1	
14	0228100370	RUBBER SEAL	1	
15	0228100280	RUBBER SEAL	1	
16	0228100365	RUBBER SEAL	1	
17	0228100070	RUBBER SEAL	1	

# DCA-125SSJU NAMEPLATE AND DECALS

## NAMEPLATE AND DECALS



# DCA-125SSJU NAMEPLATE AND DECALS

## NAMEPLATE AND DECALS

<u>NO.</u>	<u>PART NO.</u>	<u>PART NAME</u>	<u>QTY.</u>	<u>REMARKS</u>
1	M1550000204	DECAL; NOTE .....	1	M15000020
2	M1550000703	DECAL; AUXILLIARY OUTPUT .....	1	M15000070
3	M3550000004	DECAL; NOTE .....	1	M35000000
4	M3550000102	DECAL; GENERATOR CONTROL .....	1	M35000010
5	M3552000013	DECAL; ENGINE OPERATING .....	1	M35200001
6	M3552000103	DECAL; OPERATING PROCEDURES .....	1	M35200010
7	M9500000004	DECAL; OIL DRAIN PLUG .....	1	M90000000
8	M9500100004	DECAL; WATER .....	1	M90010000
9	M9500300004	DECAL; - .....	1	M90030000
10	M9500300104	DECAL; + .....	1	M90030010
11	M9503000004	DECAL; WARNING MOVING PARTS .....	1	M90300000
12	M9503000103	DECAL; OIL CHECK .....	1	M90310010
13	M9503100004	DECAL; WARNING HOT COOLANT .....	1	M90310000
14	M9503200004	DECAL; WARNING ENGINE EXHAUST .....	1	M90320000
15	M9510100004	DECAL; CAUTION HOT PARTS .....	1	M91010000
16	M9520000004	DECAL; GROUND .....	1	M92000000
17	M9520000104	DECAL; AMMETER CHANGE-OVER SW. ..	1	M92000010
18	M9520000204	DECAL; VOLTMETER CHANGE-OVER SW.	1	M92000020
19	M9520100004	DECAL; WARNING ELECTRICAL SHOCK HAZARD .....	2	M92010000
20	M9520100204	DECAL; CAUTION .....	1	M92010020A
21	M9520100304	DECAL; SAFETY INSTRUCTIONS .....	1	M92010030
22	M9520100404	DECAL; DANGER HIGH VOLTAGE .....	1	M92010040
23	M9520100503	DECAL; WARNING .....	1	M92010050
24	M9520200003	DECAL; CONNECTION OF OUTPUT CABLE .....	1	M92020000
25	M9520200104	DECAL; OVER CURRENT RELAY .....	1	M92020010
26	B152000103	DECAL; CAUTION .....	2	B15200010
27	C95053000004	DECAL; CAUTION .....	1	C90530000
28	M9522000004	DECAL; WATER HEATER	1	
29	M9522000104	DECAL; BATTERY CHARGER	1	
30	9039209064	DECAL; START CONTACT .....	1	S-4468
31	M9508200004	DECAL; FUEL VALVE OPERATING .....	1	M90820000

**PAYMENT TERMS**

Terms of payment for parts are net 10 days.

**FREIGHT POLICY**

All parts orders will be shipped collect or prepaid with the charges added to the invoice. All shipments are F.O.B. point of origin. Multiquip's responsibility ceases when a signed manifest has been obtained from the carrier, and any claim for shortage or damage must be settled between the consignee and the carrier.

**MINIMUM ORDER**

The minimum charge for orders from Multiquip is \$15.00 net. Customers will be asked for instructions regarding handling of orders not meeting this requirement.

**RETURNED GOODS POLICY**

Return shipments will be accepted and credit will be allowed, subject to the following provisions:

1. A Returned Material Authorization must be approved by Multiquip prior to shipment.
2. To obtain a Return Material Authorization, a list must be provided to Multiquip Parts Sales that defines item numbers, quantities, and descriptions of the items to be returned.
  - a. The parts numbers and descriptions must match the current parts price list.
  - b. The list must be typed or computer generated.
  - c. The list must state the reason(s) for the return.
  - d. The list must reference the sales order(s) or invoice(s) under which the items were originally purchased.
  - e. The list must include the name and phone number of the person requesting the RMA.
3. A copy of the Return Material Authorization must accompany the return shipment.

4. Freight is at the sender's expense. All parts must be returned freight prepaid to Multiquip's designated receiving point.
5. Parts must be in new and resalable condition, in the original Multiquip package (if any), and with Multiquip part numbers clearly marked.
6. The following items are not returnable:
  - a. Obsolete parts. (If an item is listed in the parts price book as being replaced by another item, it is obsolete.)
  - b. Any parts with a limited shelf life (such as gaskets, seals, "O" rings, and other rubber parts) that were purchased more than six months prior to the return date.
  - c. Any line item with an extended dealer net price of less than \$5.00.
  - d. Special order items.
  - e. Electrical components.
  - f. Paint, chemicals, and lubricants.
  - g. Decals and paper products.
  - h. Items purchased in kits.
7. The sender will be notified of any material received that is not acceptable.
8. Such material will be held for 5 working days from notification, pending instructions. If a reply is not received within 5 days, the material will be returned to the sender at his expense.
9. Credit on returned parts will be issued at dealer net price at time of the original purchase, less a 15% restocking charge.
10. In cases where an item is accepted for which the original purchase document can not be determined, the price will be based on the list price that was effective twelve months prior to the RMA date.
11. Credit issued will be applied to future purchases only.

**PRICING AND REBATES**

Prices are subject to change without prior notice. Price changes are effective on a specific date and all orders received on or after that date will be billed at the revised price. Rebates for price declines and added charges for price increases will not be made for stock on hand at the time of any price change.

Multiquip reserves the right to quote and sell direct to Government agencies, and to Original Equipment Manufacturer accounts who use our products as integral parts of their own products.

**SPECIAL EXPEDITING SERVICE**

A \$20.00 to \$50.00 surcharge will be added to the invoice for special handling including bus shipments, insured parcel post or in cases where Multiquip must personally deliver the parts to the carrier.

**LIMITATIONS OF SELLER'S LIABILITY**

Multiquip shall not be liable here under for damages in excess of the purchase price of the item with respect to which damages are claimed, and in no event shall Multiquip be liable for loss of profit or good will or for any other special, consequential or incidental damages.

**LIMITATION OF WARRANTIES**

No warranties, express or implied, are made in connection with the sale of parts or trade accessories nor as to any engine not manufactured by Multiquip. Such warranties made in connection with the sale of new, complete units are made exclusively by a statement of warranty packaged with such units, and Multiquip neither assumes nor authorizes any person to assume for it any other obligation or liability whatever in connection with the sale of its products. A part from such written statement of warranty, there are no warranties, express, implied or statutory, which extend beyond the description of the products on the face hereof.



## **HERE'S HOW TO GET HELP**

*PLEASE HAVE THE MODEL AND SERIAL NUMBER  
ON-HAND WHEN CALLING*

### ***PARTS DEPARTMENT***

*800/427-1244 or 310/537-3700*

*FAX: 800/672-7877 or 310/637-3284*

### ***SERVICE DEPARTMENT***

*800/835-2551 or 310/537-3700*

*FAX: 310/638-8046*

### ***WARRANTY DEPARTMENT***

*800/835-2551 or 310/537-3700*

*FAX: 310/638-8046*

### ***MAIN***

*800/421-1244 or 310/537-3700*



#### **MULTIQUIP INC.**

18910 WILMINGTON AVE.  
CARSON, CALIFORNIA 90746  
310-537-3700  
800-421-1244  
FAX: 310-537-3927

#### **PARTS DEPARTMENT:**

800-427-1244  
FAX: 800-672-7877

#### **SERVICE DEPARTMENT:**

800-835-2551  
FAX: 310-638-8046

**E-mail: [mq@multiquip.com](mailto:mq@multiquip.com) • [www.multiquip.com](http://www.multiquip.com)**