

PARTS AND OPERATION MANUAL

MQ POWER DCA-220SSK PORTABLE GENERATOR FOR General Electric Equipment Rental (GEER)

© COPYRIGHT 2001, MULTIQIP INC.

2000 -S/N 3698950~
1999-S/N 3696501 TO 3698949

Revision #1(03/14/01)



MULTIQIP INC.
18910 WILMINGTON AVE.
CARSON, CALIFORNIA 90746
310-537-3700
800-421-1244
FAX:310-537-3927

PARTS DEPARTMENT:

800-427-1244
FAX: 800-672-7877

SERVICE DEPARTMENT:

800-835-2551
FAX:310-638-804

E-mail:mq@multiquip.com • www.multiquip.com



WARNING



CALIFORNIA — Proposition 65 Warning

Diesel engine exhaust and some of its constituents are known to the State of California to cause cancer, birth defects and other reproductive harm.

HERE'S HOW TO GET HELP

*PLEASE HAVE THE MODEL AND SERIAL NUMBER
ON-HAND WHEN CALLING*

PARTS DEPARTMENT

800/427-1244 or 310/537-3700

FAX: 800/672-7877 or 310/637-3284

SERVICE DEPARTMENT

800/835-2551 or 310/537-3700

FAX: 310/638-8046

WARRANTY DEPARTMENT

800/835-2551 or 310/537-3700

FAX: 310/638-8046

MAIN

800/421-1244 or 310/537-3700

FAX: 310/537-3927

TABLE OF CONTENTS

Here's How To Get Help	3
Table Of Contents	4
Parts Ordering Procedures	5
Rules for Safe Operation	6-9
Towing Safety Precaution	10
Trailer Safety Guidelines	11-17
Trailer Wiring Diagram	18
Electric Brake Troubleshooting	19
Hydraulic Brake Troubleshooting	20
Operation and Safety Decals	21-24
DCA 220 Specifications	25

MQPower DCA 220SSK AC Generator

General Information	26-28
Major Components	29
Dimensions	30-31
Control Panel Descriptions	32-33
Engine Operating Panel Descriptions	34-35
Output Terminal Panel Descriptions	36-37
Installation	38-39
Pre Set-up	40-43
Load Application	44
Generator Start-up Procedure, Manual	45-49
Generator Start-up Procedure, Auto	50
Generator Shut-Down Procedure	51
Maintenance	52-53
Generator Wiring Diagram	54
Engine Wiring Diagram	55
Engine Troubleshooting	56-57

Generator/Engine Troubleshooting	58
MPEC Troubleshooting	59
Explanation of Code in Remarks Column	60
Suggested Spare Parts	61
Generator Assembly	62-65
Control Panel Assembly	66-67
Control Box Assembly	68-71
Engine & Radiator Assembly	72-75
Engine Operating Panel Assembly	76-77
Governor Actuator Assembly	78-79
Output Terminal Assembly	80-81
Battery Assembly	82-83
Muffler Assembly	84-85
Fuel Water Separator Assembly S/N3698950~	86-87
Fuel Water Separator Assembly S/N3696501 TO S/N3698949	88-89
Jacket Water Heater Assembly	90-91
Enclosure Assembly	92-97
Rubber Seal Assembly	98-99
Name Plate And Decals	100-103
Terms and Condition of Sale — Parts	104

NOTE

***Specification and part
number are subject to
change without notice.***

- Dealer account number
- Dealer name and address
- Shipping address (if different than billing address)
- Return fax number
- Applicable model number
- Quantity, part number and description of each part
- Specify preferred method of shipment:
 - UPS Ground
 - UPS Second Day or Third Day*
 - UPS Next Day*
 - Federal Express Priority One (please provide us with your Federal Express account number)*
 - Airborne Express*
 - Truck or parcel post

**Normally shipped the same day the order is received, if prior to 2PM west coast time.*

Earn Extra Discounts when you order by FAX!

All parts orders which include complete part numbers and are received by fax qualify for the following extra discounts:

Number of line items ordered	Additional Discount
1-9 items	3%
10+ items**	5%

Get special freight allowances when you order 10 or more line items via FAX! **

- UPS Ground Service at no charge for freight
- PS Third Day Service at one-half of actual freight cost

No other allowances on freight shipped by any other carrier.

**Common nuts, bolts and washers (all items under \$1.00 list price) do not count towards the 10+ line items.

DISCOUNTS ARE SUBJECT TO CHANGE

Fax order discount and UPS special programs revised June 1, 1995

Extra Fax Discount for Domestic USA Dealers Only

Up to 5% extra savings!

UPS Special
For faxed orders only

Now! Direct TOLL-FREE access to our Parts Department!

Toll-free nationwide:

800-421-1244

Toll-free FAX:

800/6-PARTS-7 • 800-672-7877

RULES FOR SAFE OPERATION

CAUTION:



Failure to follow instructions in this manual may lead to serious injury or even death! This equipment is to be operated by trained and qualified personnel only! This equipment is for industrial use only.

The following safety guidelines should always be used when operating the DCA-220SSK portable generator:

GENERAL SAFETY

- **DO NOT** operate or service this equipment before reading this entire manual.



- This equipment should not be operated by persons under 18 years of age.



- **NEVER** operate this equipment without proper protective clothing, shatterproof glasses, steel-toed boots and other protective devices required by the job.

- **NEVER** operate this equipment when not feeling well due to fatigue, illness or taking medicine.



- **NEVER** operate this equipment under the influence of drugs or alcohol.



- **NEVER** use accessories or attachments, which are not recommended by MQ Power for this equipment. Damage to the equipment and/or injury to user may result.

- Manufacturer does not assume responsibility for any accident due to equipment modifications.

- Whenever necessary, replace nameplate, operation and safety decals when they become difficult read.

- Always check the machine for loosened threads or bolts before starting.

- **NEVER** touch the hot exhaust manifold, muffler or cylinder. Allow these parts to cool before servicing engine or generator.



- **High Temperatures** – Allow the engine to cool before adding fuel or performing service and maintenance functions. Contact with *hot* components can cause serious burns.

- The engine of this generator requires an adequate free flow of cooling air. Never operate the generator in any enclosed or narrow area where free flow of the air is restricted. If the air flow is restricted it will cause serious damage to the generator or engine and may cause injury to people. The generator engine gives off **DEADLY** carbon monoxide gas.

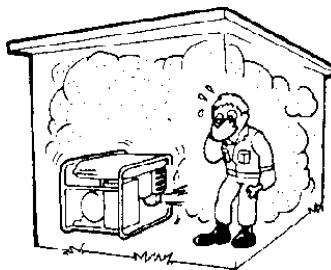

CAUTION:



Always refuel in a well-ventilated area, away from sparks and open flames.



- Always use extreme **CAUTION** when working with **flammable** liquids. When refueling, **stop the engine** and allow it to cool. **DO NOT** smoke around or near the machine. Fire or explosion could result from fuel vapors, or if fuel is spilled on a hot engine.

- **NEVER** operate the generator in an explosive atmosphere or near combustible materials. An explosion or fire could result causing severe *bodily harm or even death*.

- Topping-off to filler port is dangerous, as it tends to spill fuel.

RULES FOR SAFE OPERATION

CAUTION:

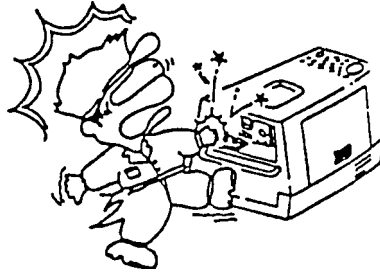

- **NEVER** touch output terminals during operation. This is extremely dangerous. Always stop the machine when contact with the output terminals.

CAUTION:

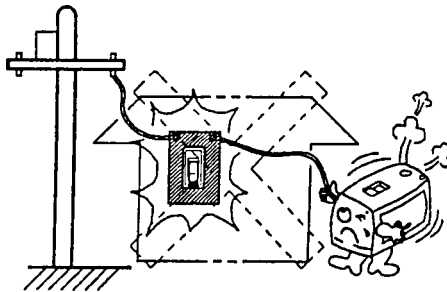

- **Backfeed** to a utility system can cause electrocution and/or property damage. Do not connect to any building's electrical system except through an approved device or after building main switch is opened.

CAUTION:



- **Never** use damaged or worn cables when connecting power tools or equipment to the generator. Make sure power connecting cables are securely connected to the generator's output terminals, insufficient tightening of the terminal connections may cause damage to the generator and electrical shock.

CAUTION:



DO NOT touch or open any of the below mentioned components while the generator is running. Always allow sufficient time for the engine and generator to cool before performing maintenance.

Radiator

1. **Radiator Cap** - Removing the radiator cap while the engine is hot will result in high pressurized, boiling water to gush out of the radiator, therefore causing severe scalding to any persons in the general area of the generator.

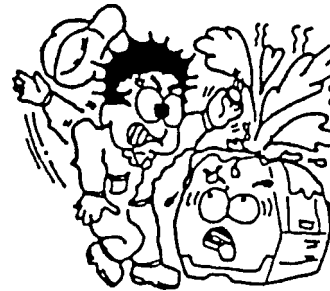

2. **Coolant Drain Plug** - Removing the coolant drain plug while the engine is hot will result in hot coolant to gush out of the coolant drain plug, therefore causing severe scalding to any persons in the general area of the generator.
3. **Engine Oil Drain Plug** - Removing the engine oil drain plug while the engine is hot will result in hot oil to gush out of the oil drain plug, therefore causing severe scalding to any persons in the general area of the generator.

Battery CAUTION:



Never over fill the battery with water above the upper limit.

The battery contains acids that can cause injury to the eyes and skin. To avoid eye irritation, always wear safety glasses. Use well insulated gloves when picking up the battery. Use the following guidelines when handling the battery:

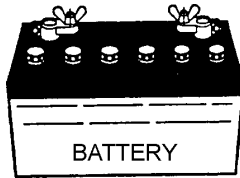

1. **DO NOT** drop the battery. There is the possibility of risk that the battery may explode.
 2. **DO NOT** expose the battery to open flames, sparks, cigarettes etc. The battery contains combustible gases and liquids. If these gases and liquids come in contact with a flame or spark, an explosion could occur.
 3. Always keep the battery charged. If the battery is not charged a buildup of combustible gas will occur.
 4. Always keep battery charging and booster cables in good working condition. Repair or replace all worn cables.
 5. Always recharge the battery in an open air environment, to avoid risk of a dangerous concentration of combustible gases.
 6. In case the battery liquid (dilute sulfuric acid) comes in contact with **clothing or skin**, rinse skin or clothing immediately with plenty of water.
 7. In case the battery liquid (dilute sulfuric acid) comes in contact with your **eyes**, rinse eyes immediately with plenty of water, then contact the nearest doctor or hospital, and seek medical attention.
- **NEVER** Run engine without air filter. Severe engine damage may occur.
 - Always service air cleaner frequently to prevent carburetor malfunction.
 - Always disconnect the battery before performing service on the generator.
 - Always be sure the operator is familiar with proper safety precautions and operations techniques before using generator.
 - Always store equipment properly when not in use. Equipment should be stored in a clean, dry location out of the reach of children.
 - **DO NOT** leave the generator running in the manual mode unattended.
 - **DO NOT** allow unauthorized people to operate this equipment.
 - Always read, understand, and follow procedures in Operator's Manual before attempting to operate equipment.
 - Refer to the ***Komatsu Engine Owner's Manual*** for engine technical questions or information.

Loading and Unloading (Crane)

- Before lifting, make sure the generator's lifting hook is secure and that there is no apparent damage to the generator itself (loose screws, nuts and bolts). If any part is loose or damaged, please take corrective action before lifting.
- Always drain fuel prior to lifting.
- Always make sure crane or lifting device has been properly secured to the hook of guard frame on generator.
- **NEVER** lift the machine while the engine is running.
- Use adequate lifting cable (wire or rope) of sufficient strength.
- When lifting the generator, always use the balanced center-point suspension hook and lift straight upwards.
- **NEVER** allow any person or animal to stand underneath the machine while lifting.
- When loading the generator on a truck, be sure to use the front and back frame bars as a means to secure the generator during transport.

RULES FOR SAFE OPERATION

Transporting

- Always shutdown engine before transporting.
- Tighten fuel tank cap securely.
- Drain fuel when transporting generator over long distances or bad roads.
- Always tie-down the generator during transportation by securing the generator.
- If generator is mounted on a trailer, make sure trailer complies with all local and state safety transportation laws. See page 10 for basic towing procedures.

Emergencies

- Always know the location of the nearest **fire extinguisher** and **first aid kit**. Know the location of the nearest telephone. Also know the phone numbers of the nearest **ambulance**, **doctor** and **fire department**.

Maintenance Safety

- **NEVER** lubricate components or attempt service on a running machine.
- Always allow the machine a proper amount of time to cool before servicing.
- Keep the machinery in proper running condition.
- Fix damage to the machine immediately and always replace broken parts.
- Dispose of hazardous waste properly. Examples of potentially hazardous waste are used motor oil, coolant, fuel, and fuel filters.
- **DO NOT** use plastic containers to dispose of hazardous waste.
- **DO NOT** pour waste, oil, coolant or fuel directly onto the ground, down a drain or into any water source

Towing Safety Precautions

CAUTION :



Check with your county or state safety towing regulations department before towing your generator.

To reduce the possibility of an accident while transporting the generator on public roads, always make sure the trailer (Figure 1) that supports the generator and the towing vehicle are in good operating condition and both units are mechanically sound.

The following list of suggestions should be used when towing your generator:

- Make sure the hitch and coupling of the towing vehicle are rated equal to, or greater than the trailer "gross vehicle weight rating" (GVWR).
- **ALWAYS** inspect the hitch and coupling for wear. **NEVER** tow a trailer with defective hitches, couplings, chains etc.
- Check the tire air pressure on both towing vehicle and trailer. Also check the tire tread wear on both vehicles.
- **ALWAYS** make sure the trailer is equipped with a "Safety Chain".

- **ALWAYS** attach trailer's safety chain to bumper of towing vehicle.
- **ALWAYS** make sure the vehicle and trailer directional, backup, brake, and trailer lights are connected and working properly.
- Remember the maximum speed unless otherwise posted for highway towing is **45 MPH**. Recommended off-road towing is not to exceed **10 MPH** or less depending on type of terrain.
- Place *chocked blocks* underneath wheel to prevent **rolling**, while parked.
- Place *support blocks* underneath the trailer's bumper to prevent **tipping**, while parked.
- Use the trailer's hand winch to adjust the height of the trailer, then insert locking pin to lock wheel stand in place, while parked.
- Avoid sudden stops and starts. This can cause skidding, or jackknifing. Smooth, gradual starts and stops will improve gas mileage.
- Avoid sharp turns to prevent rolling.
- Remove wheel stand when transporting.
- **DO NOT** transport generator with fuel in tank.

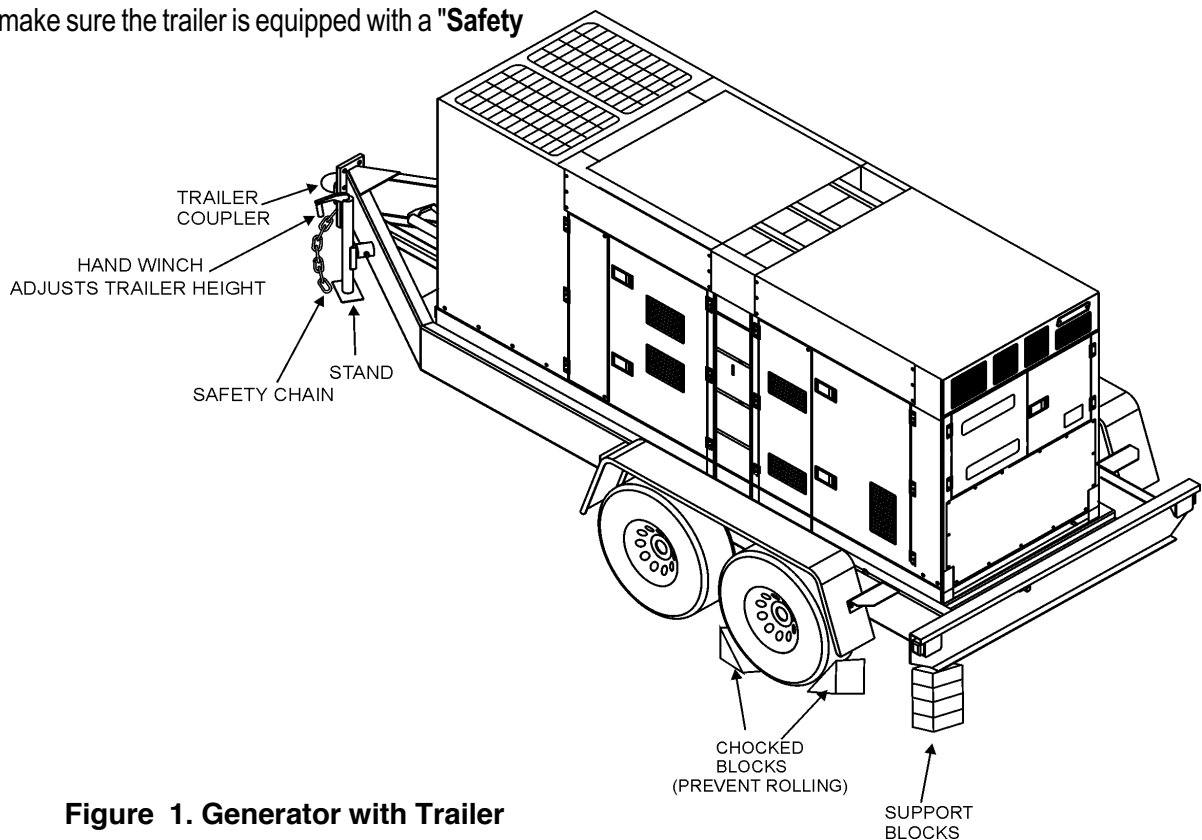

Figure 1. Generator with Trailer

CAUTION:



ALWAYS make sure the trailer is in good operating condition. Check the tires for proper inflation and wear. Also check the wheel lug nuts for proper tightness.

Explanation of Chart:

This section is intended to provide the user with trailer service and maintenance information. The service and maintenance guidelines referenced in this section apply a wide range of trailers. Remember periodic inspection of the trailer will ensure safe towing of the equipment and will prevent damage to the equipment and personal injury.

It is the purpose of this section to cover the major maintenance components of the trailer. The following trailer components will be discussed in this section:

- Brakes
- Tires
- Lug Nut Torquing
- Suspension
- Electrical
- Brake Troubleshooting Tables

Use the following definitions with reading Table 1.

1. **Fuel Cell** - Provides an adequate amount of fuel for the equipment in use. fuel cells must be empty when transporting equipment.
2. **Braking System** - System employed in stopping the trailer. Typical braking systems are electric, surge, hydraulic, hydraulic-surge and air.
3. **GVWR**- Gross Vehicle Weight Rating (GVWR), is the maximum number of pounds the trailer can carry, including the fuel cell (empty).
4. **Frame Length** - This measurement is from the ball hitch to the rear bumper (reflector).
5. **Frame Width** - This measurement is from fender to fender.
6. **Jack Stand** - Trailer support device with maximum pound requirement from the tongue of the trailer.
7. **Coupler** - Type of hitch used on the trailer for towing.
8. **Tire Size** - Indicates the diameter of the tire in inches (10,12,14, etc.), and the width in millimeters (175,185,205, etc.). The tire diameter must match the diameter of the tire rim.
9. **Tire Ply** - The tire ply (layers) number is rated in letters; 2-ply,4-ply,6-ply, etc.
10. **Wheel Hub** - Thr wheel hub is connected to the trailer's axle.
11. **Tire Rim** - Tires mounted on a tire rim. The tire rim must match the size of the tire.
12. **Lug Nuts** - Used to secure the wheel to the wheel hub. Always use a torque wrench to tighten down the lug nuts. See Table 4 and Figure 5 or lug nut tightening and sequence.
13. **Axle** - Indicates the maximum weight the axle can support in pounds, and the diameter of the axle expressed in inches (see Table 3). Please not that some trailers have a double axle. this will be shown as 2-6000 lbs., meaning two axles with a total weight capacity of 6000 pounds.
14. **Suspension** - Protects the trailer chassis from shocks transmitted through the wheels. Types of suspension used are leaf, Q-flex, and air ride.
15. **Electrical** - Electrical connectors (looms) are provided with the trailer so the brake lights and turn signals can be connected to the towing vehicle. See Figure 19 for proper wiring connections.
16. **Application** - Indicates which units can be employed on a particular trailer.

DCA-220SSK —TRAILER-SPECIFICATIONS

Table 1. Specifications

MODEL	APPLICATION	FUEL CELL	BRAKE SYSTEM	GVWR	FRAME LENGTH	FRAME WIDTH	JACK STAND
TRLR-10-15	TLG-12, DCA15, TLW-300	NO	NO	1900LBS	96"	50"	800LB. FULL TILT WHEEL
TRLR-10X	TLG-12, DCA15, TLW-300	NO	NO	1900LBS	96"	50"	800LB. FULL TILT WHEEL
TRLR-10XF	TLG-12, DCA15, TLW-300	51 GAL	NO	1900LBS	96"	50"	800LB. FULL TILT WHEEL
TRLR-225W	DCA-10	NO	NO	2200LBS	85"	42"	800LB. FULL TILT WHEEL
BLW-400	BLW-400	NO	ELECTRIC	2700LBS	W/MAST 154" W/O 124"	55" (78" TALL)	800LB. FULL TILT WHEEL
TRLR-15XF	DCA-15	41 GAL	NO	2700LBS	124"	55"	800LB. FULL TILT WHEEL
TRLR-50X	DCA-25	NO	NO	2700LBS	124"	55"	800LB. FULL TILT WHEEL
TRLR-50XF	DCA-25	41 GAL	NO	2700LBS	124"	55"	800LB. FULL TILT WHEEL
TRLR-25SBT	DCA-25	NO	NO	2990LBS	120"	66"	800LB. FULL TILT WHEEL
TRLR-70W	DCA-45, -60, 70	NO	SURGE	7000LBS	186"	77"	2000LB. FLAT PAD
TRLR-70X	DCA-45, -60, 70	OPT	SURGE	7000LBS	138"	66"	2000LB. FLAT PAD
TRLR-70XF	DCA-45, -60, 70	53 GAL	SURGE	7000LBS	138"	66"	2000LB. FLAT PAD
TRLR-100XF	DCA-100, 125	150 GAL	HYDRAULIC SURGE	7000LBS	190"	76"	2000LB. FLAT PAD
TRLR-85/125	DCA-85, 100, 125	145 GAL	HYDRAULIC	10000LBS	186"	77"	2000LB. FLAT PAD
TRLR-150XF	DCA-150, 180	200 GAL	HYDRAULIC SURGE	11160LBS	204"	84"	5000 LB. FLAT PAD
TRLR-220XF	DCA-220	250 GAL	HYDRAULIC SURGE	14000LBS	222"	83"	5000 LB. FLAT PAD
TRLR-300XF	DCA-300	250 GAL	HYDRAULIC SURGE	18000LBS	238"	83"	5000 LB. FLAT PAD
TRLR-400XF	DCA-400	350 GAL	ELECTRIC	18000LBS	238"	83"	5000 LB. FLAT PAD
TRLR-600XF	DCA-600, 800	550 GAL	AIR	30000LBS	384"	96"	5000 LB. FLAT PAD
TRLR-800SX	DCA-600, 800	550 GAL	AIR	30000LBS	384"	96"	5000 LB. FLAT PAD

DCA-220SSK —TRAILER-SPECIFICATIONS

Table 1. Specifications (Con't)

MODEL	COUPLER	TIRES	WHEELS	AXLE	HUBS	SUSPENSION	ELECTRICAL
TRLR-10-15W	2" BALL CLASS 2 ADJUSTABLE	175-13C	13"X4.50"	2200# 2X2	5 LUG	3 LEAF	4 WIRE LOOM W/ 4 POLE FLAT
TRLR-10X	2" BALL CLASS 2 ADJUSTABLE	175-13C	13"X4.5"	2200#2X2	5 LUG	3 LEAF	4 POLE FLAT
TRLR-10XF	2" BALL CLASS 2 ADJUSTABLE	175-13C	13"X4.5"	2200#2X2	5 LUG	3 LEAF	4 POLE FLAT
TRLR-225W	2" BALL CLASS 2 ADJUSTABLE	175-13B	13X4.5"	2200#2X2	5 LUG	Q FLEX	4 POLE FLAT
BLW 400	2" BALL CLASS 2 ADJUSTABLE	175-13C	13 X 4.5"	2200#2X2	5 LUG	3 LEAF	4 POLE FLAT
TRLR-15XF	2" BALL CLASS	B78-13LRC	13"X4.50"	3500# 2-1/2"	5 LUG	4 LEAF	4 POLE RUBBER FLAT
TRLR-50X	2" BALL CLASS	B78-13LRC	13"X4.50"	3500lbs. 2-3/8"	5 LUG	4 LEAF	4 POLE RUBBER FLAT
TRLR-50XF	2" BALL CLASS	B78-13LRC	13"X4.50"	3500lbs. 2-3/8"	5 LUG	4 LEAF	4 POLE RUBBER FLAT
TRLR-70W	2" BALL CLASS 3" ADJUSTABLE	205-14C BIAS (4)	14"X5"	3500lbs. 3"	5 LUG	5 LEAF	4 POLE RUBBER FLAT
TRLR-70X	2" BALL CLASS 3" ADJUSTABLE	205-14C BIAS (4)	14"X5"	3500lbs 3"	5 LUG	5 LEAF	4 POLE RUBBER FLAT
TRLR-70XF	2" BALL CLASS 3" ADJUSTABLE	205-14C BIAS (4)	14"X5"	3500lbs. 3"	5 LUG	5 LEAF	4 POLE RUBBER FLAT
TRLR-100XF	ADJUSTABLE 2-5/6 OPT 3" EYE	205-15C BIAS (4)	14"X5.5"	3500lbs 3"	5 LUG	5 LEAF	4 WIRE LOOM
TRLR-85/125	ADJUSTABLE 2-5/6 OPT 3" EYE	ST225/75R15D RADIAL (4)	14"x6"	(2)-6000lbs	6 LUG	7 LEAF	4 WIRE LOOM
TRLR-150XF	3" BALL EYE	750-16 E BIAS (4)	16"X7"	(2)-6000lbs	8 LUG	7 LEAF	4 WIRE LOOM
TRLR-220XF	3" EYE ADJUSTABLE	ST235/85R16E RADIAL(4)	16"X7"	(2)-7000lbs	8 LUG	Q FLEX	4 WIRE LOOM
TRLR-300XF	3" EYE ADJUSTABLE	ST235/85R16E RADIAL(6)	16"X7"	(2)-6000lbs	8 LUG	Q FLEX	4 WIRE LOOM
TRLR-400XF	3" EYE ADJUSTABLE	ST235/85R16E RADIAL(6)	16"X7"	(3)-7000lbs.	8 LUG	Q FLEX	4 WIRE LOOM
TRLR-600XF	5TH WHEEL	ST215/75R17.5H RADIAL (8)	16"X7"	(3)-10000lbs	8 LUG	7 LEAF	6 WIRE LOOM
TRLR-800AR	5TH WHEEL	ST215/75R17.5H RADIAL (8)	16"X7"	(3)-10000lbs	8 LUG	AIR-RIDE	6 WIRE LOOM

Brakes

If your trailer has a braking system, the brakes should be inspected the first 200 miles of operation. This will allow the brake shoes and drums to seat properly. After the first 200 mile interval, inspect the brakes every 3,000 miles. If driving over rough terrain, inspect the brakes more frequently.

Electric Brakes

Electrically actuated brakes (Figure 2) are similar to hydraulic brakes. The basic difference is that hydraulic brakes are actuated by an electromagnet.

Listed below are some of the advantages that electric brakes have over hydraulic brakes:

- Brake system can be manually adjusted to provide the corrected braking capability for varying road and load conditions
- Brake system can be modulated to provide more or less braking force, thus easing the brake load on the towing vehicle
- Brake system has very little lag time between the time the vehicle's brakes are actuated and the trailer's brakes are actuated
- Brake system can provide an independent emergency brake system

Remember in order to properly synchronize the tow vehicle's braking to the trailer's braking, can only be accomplished by road testing. Brake lockup, grabbiness or harshness is due to lack of synchronization between the tow vehicle and the trailer being towed or under-adjusted brakes.

Before any brake synchronizations adjustments can be made, the trailer brakes should be burnished-in by applying the brakes 20-30 times with approximately a 20 m.p.h. decrease in speed, e.g. 40 m.p.h. to 20 m.p.h. Allow ample time for brakes to cool between application. This allows the brake shoes to slightly be seated into the brake drum surface.

Figure 2 displays the major electric brake components that will require inspection and maintenance. Please inspect these components as required.

Electric Brake Adjustment

1. Place the trailer on jack stands. Make sure the jack stands are placed on secure level ground.
2. Check the wheel and drum for free rotation.
3. Remove the adjusting hole cover from the adjusting slot at the bottom brake backing plate.
4. With a screwdriver or standard adjusting tool, rotate the star wheel of the adjuster assembly to expand the brake shoes.
5. Adjust the brake shoes outward until the pressure of the lining against the wheel drum makes the wheel difficult to turn.
6. Rotate the star wheel in the opposite direction until the wheel rotates freely with slight lining drag.
7. Replace the adjusting hole cover and lower the trailer to the ground.
8. Repeat steps 1 through 6 on the remaining brakes.

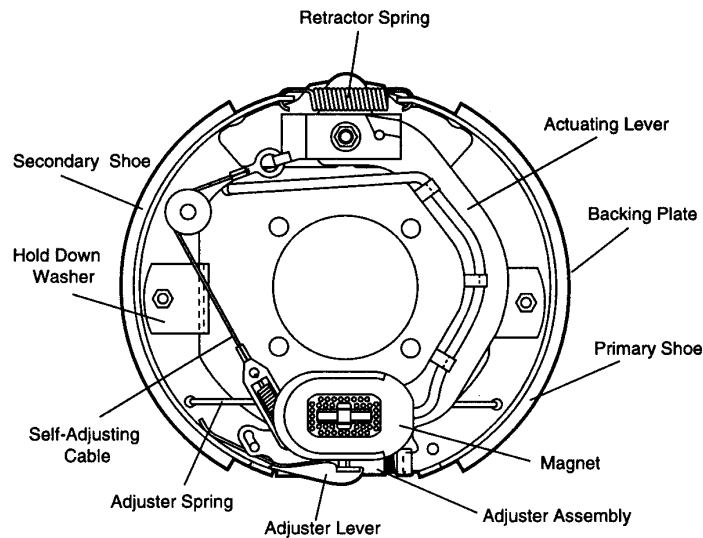

Figure 2. Electrical Brake Components

Hydraulic/Air/Surge Brakes

Hydraulic brakes (Figure 3) should not require any special attention with the exception of routine maintenance such as shoe and lining replacement. These brakes can be adjusted in the same manner as electric brakes. Brake lines should be periodically checked for cracks, kinks, or blockage.

Figure3 below displays the major hydraulic/air/surge brake components that will require inspection and maintenance. Please inspect these components as required using steps 1 through 6 as referenced in the electric brake adjustments section.

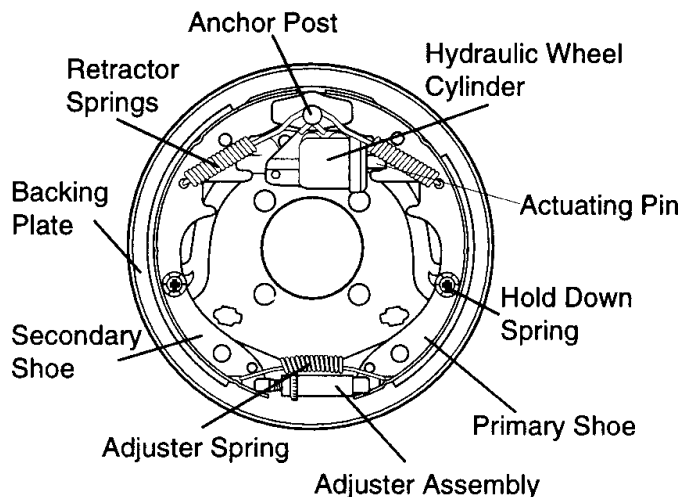

Figure 3. Hydraulic Brake Components

Tires/Wheels/Lug Nuts

Tires and wheels are a very important and critical components of the trailer. When specifying or replacing the trailer wheels it is important the wheels, tires, and axle are properly matched.

CAUTION:



DO NOT attempt to repair or modify a wheel. DO NOT install in inner tube to correct a leak through the rim. If the rim is cracked, the

air pressure in the inner tube may cause pieces of the rim to explode (break off) with great force and cause serious eye or bodily injury.

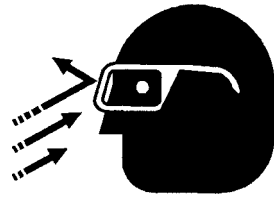

Tire Wear/Inflation

Tire inflation pressure is the most important factor in tire life. Pressure should be checked cold before operation DO NOT bleed air from tires when they are hot. Check inflation pressure weekly during use to insure the maximum tire life and tread wear.

Table 2 (Tire Wear Troubleshooting) will help pinpoint the causes and solutions of tire wear problems.

WEAR PATTERN		CAUSE	SOLUTION
	Center Wear	Over Inflation.	Adjust pressure to particular load per tire manufacturer.
	Edge Wear	Under Inflation.	Adjust pressure to particular load per tire manufacturer.
	Side Wear	Loss of camber or overloading.	Make sure load does not exceed axle rating. Align wheels.
	Toe Wear	Incorrect toe-in.	Align wheels.
	Cupping	Out-of-balance.	Check bearing adjustment and balance tires.
	Flat Spots	Wheel lockup & tire skidding.	Avoid sudden stops when possible and adjust brakes.

Suspension

The leaf suspension springs and associated components (Figure 4) should be visually inspected every 6,000 miles for signs of excessive wear, elongation of bolt holes, and loosening of fasteners. Replace all damaged parts (suspension) immediately. Torqued suspension components as detailed in Table 3.

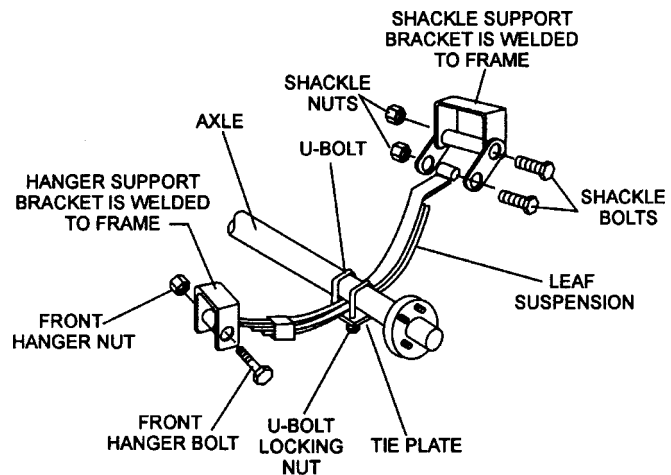
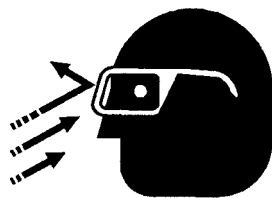
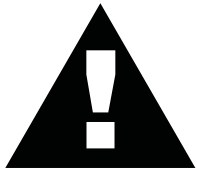

Figure 4. Major Suspension Components

CAUTION:



NOTE

ALWAYS wear safety glasses when removing or installing force fitted parts. Failure to comply may result in serious injury.

Table 3. Suspension Torque Requirements

Item	Torque (Ft.-Lbs.)
3/8" U-BOLT	MIN-30 MAX-35
7/16" U-BOLT	MIN-45 MAX-60
1/2" U-BOLT	MIN-45 MAX-60
SHACKLE BOLT SPRING EYE BOLT	SNUG FIT ONLY. PARTS MUST ROTATE FREELY. LOCKING NUTS OR COTTER PINS ARE PROVIDED TO RETAIN NUT-BOLT ASSEMBLY.
SHOULDER TYPE SHACKLE BOLT	MIN-30 MAX-50

Lug Nut Torque Requirements

It is extremely important to apply and maintain proper wheel mounting torque on the trailer. Be sure to use only the fasteners matched to the cone angle of the wheel. Proper procedure for attachment of the wheels is as follows:

1. Start all wheel lug nuts by hand.
2. Torque all lug nuts in sequence. See Figure 5. DO NOT torque the wheel lug nuts all the way down. Tighten each lug nut in 3 separate passes as defined by Table 4.
3. After first road use, retorque all lug nuts in sequence. Check all wheel lug nuts periodically.

Table 4. Tire Torque Requirements

Wheel Size	First Pass FTLBS	Second Pass FTLBS	Third Pass FTLBS
12"	20-25	35-40	50-65
13"	20-25	35-40	50-65
14"	20-25	50-60	90-120
15"	20-25	50-60	90-120
16"	20-25	50-60	90-120

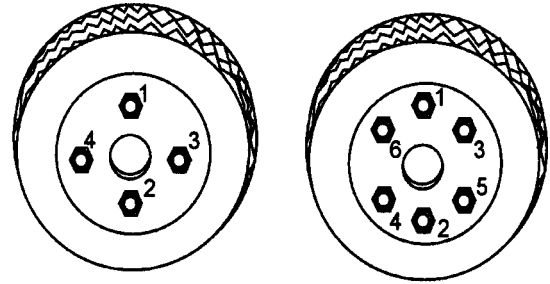

4-LUG NUTS

6-LUG NUTS

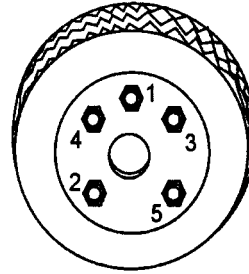

5-LUG NUTS

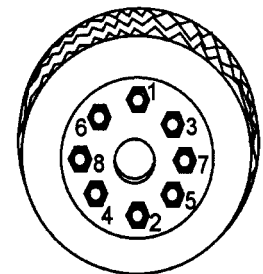

8-LUG NUTS

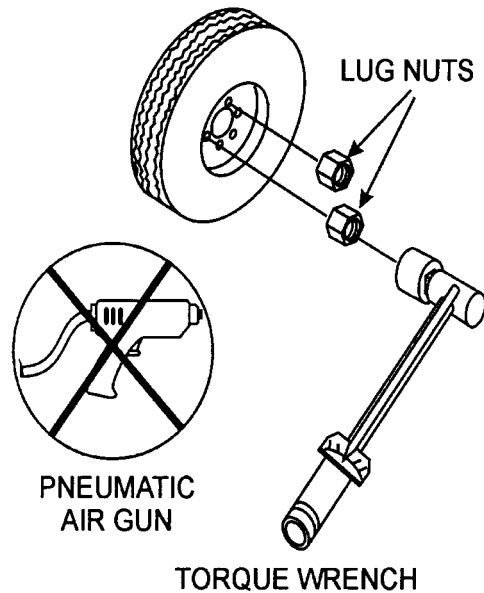
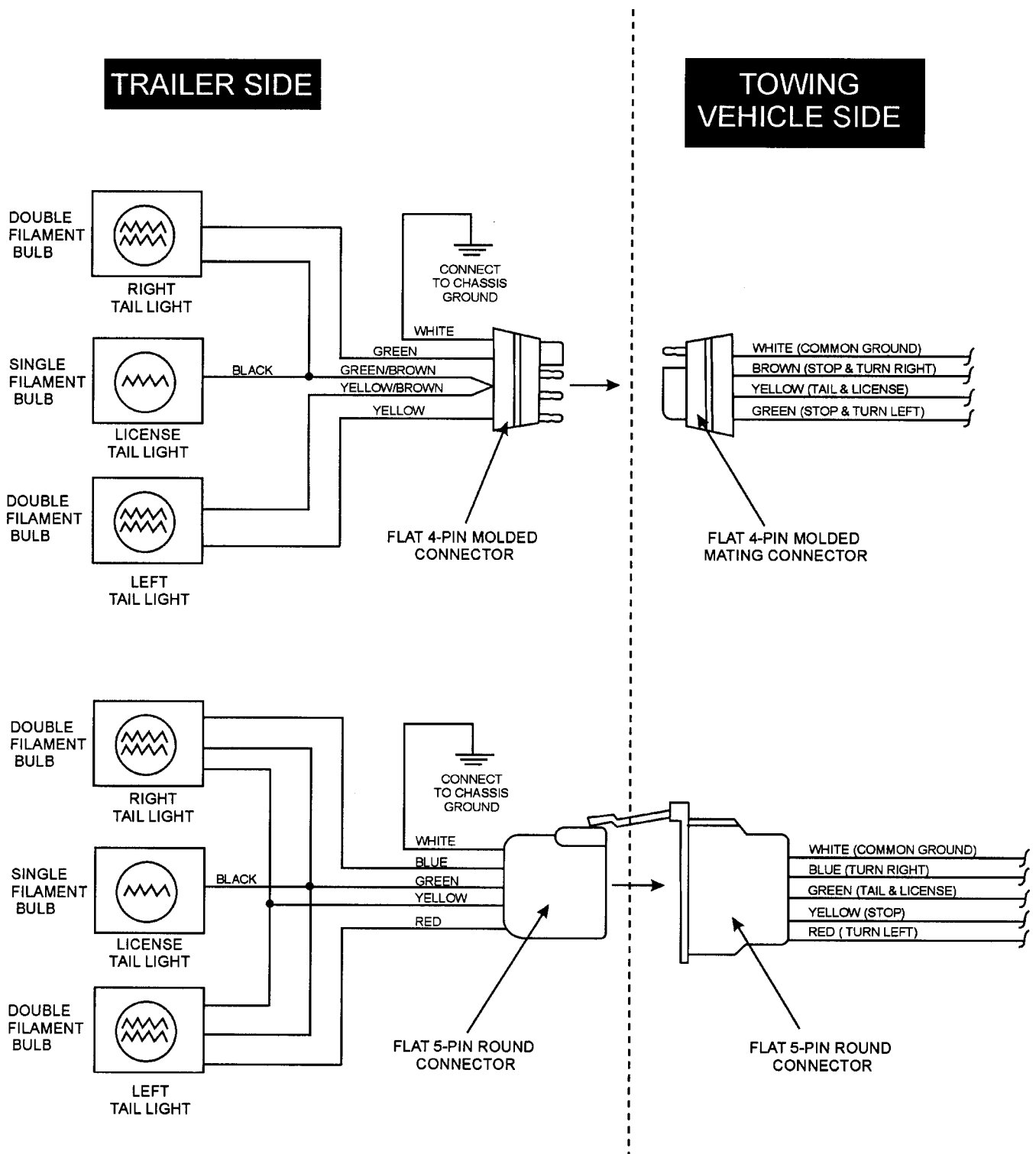

Figure 5. Wheel Lug Nuts Tightening Sequence

NOTE

NEVER use an pneumatic air gun to tighten wheel lug nuts.

DCA-220SSK — TRAILER SAFETY GUIDELINES



DCA-220SSK —TRAILER-BRAKE TROUBLESHOOTING

Table 5. Electric Brake Troubleshooting

Symptom	Possible Cause	Solution
No Brakes or Intermittent Brakes	Any open circuits or broken wires?	Find and correct.
	Any short circuits?	Find and correct.
	Faulty controller?	Test and correct.
	Any loose connections?	Find and repair.
	Ground wire secure?	Find and secure.
Weak Brakes or Brakes Pull to One Side	Grease or oil on magnets or linings?	Clean or replace.
	Connections corroded?	Clean and correct cause of corrosion.
	Brake drums scored or grooved?	Machine or replace.
	Brakes synchronized?	Correct.
Locking Brakes	Brake components loose, bent or broken?	Replace components.
	Brake drums out-of-round?	Replace.
Noisy Brakes	System lubricated?	Lubricate.
	Brake components correct?	Replace and correct.
Dragging Brakes	Bearings of the wheel adjusted?	Adjust.

DCA-220SSK —TRAILER-BRAKE TROUBLESHOOTING

Table 6. Hydraulic Brake Troubleshooting

Symptom	Possible Cause	Solution
No Brakes	Brake line broken or kinked?	Repair or replace.
Weak Brakes or Brakes Pull to One Side	Brake lining glazed?	Reburnish or replace.
	Trailer overloaded?	Correct weight.
	Brake drums scored or grooved?	Machine or replace.
	Tire pressure correct?	Inflate all tires equally.
	Tires unmatched on the same axle?	Match tires.
Locking Brakes	Brake components loose, bent or broken?	Replace components.
	Brake drums out-of-round?	Replace.
Noisy Brakes	System lubricated?	Lubricate.
	Brake components correct?	Replace and correct.
Dragging Brakes	Brake lining thickness correct or in right wrong position?	Install new shoes and linings.
	Enough brake fluid or correct fluid?	Replace rubber parts fill with dot4 fluid.

DCA-220SSK — OPERATION AND SAFETY DECALS

Machine Safety Decals

The DCA-220SSK generator is equipped with a number of safety decals. These decals are provided for operator safety and maintenance information. The illustration below and on the preceding pages shows the decals as they appear on the machine. Should any of these decals become unreadable, replacements can be obtained from your dealer.

GENERAL

HANDLING PROCEDURES

1. CHECK TO OPERATE
Prior to operating the engine, be sure to check the following items to prevent trouble and accidents:

- (1) Check lubricating oil, cooling water, and diesel fuel.
- (2) Check the tension of the fan-belt and charging generator drive belt.
- (3) Check the CIRCUIT BREAKER is turned "OFF".
- (4) Set the voltage change-over board to the rated voltage (only Dual voltage type).

2. STARTING AND OPERATING

- (1) Turn the battery switch to "ON" position.
- (2) Turn the STARTER SWITCH to "PREHEAT" position for 10 - 30 seconds.
Press the STARTER SWITCH to "START" POSITION to start the engine.
When the engine starts, release the STARTER SWITCH.
- (3) Warm-up the engine for about 5 minutes.
- (4) Rotate the THROTTLE HANDLE to "HIGH SPEED" and adjust the engine speed according to the following table:

No-load operating speed	No-load operating speed
50 Hz operating speed	Approx. 62.5 Hz (1875 rpm)
60 Hz operating speed	Approx. 62.5 Hz (1875 rpm)

- (5) Adjust the VOLTAGE REGULATOR to the rated voltage.
- (6) Turn on the CIRCUIT BREAKER to supply electric power to the load.

3. OPERATING PRECAUTIONS

- (1) When operating, do not turn the BATTERY SWITCH "OFF" to protect the charging generator and engine circuit against damage.
- (2) When the CIRCUIT BREAKER is tripped "OFF" for over current or short-circuit, check the trouble cause and repair defective parts.
The CIRCUIT-BREAKER cannot be reset unless it is once turned "OFF" and next turned "ON".

4. STOPPING THE ENGINE

- (1) Turn the Circuit Breaker to "OFF".
Rotate the THROTTLE HANDLE TO THE "Low Speed" side.
Cool down the engine for about 5 minutes.
- (2) Depress the STOP BUTTON.
After the engine stops completely, turn "OFF" STARTER SWITCH and BATTERY SWITCH.

S-2763

P/N 0800655603

CONTROL BOX GROUP

SAFETY INSTRUCTIONS

Improper operation of this machine can cause severe injury or death.

- Read the instruction manual carefully before operating or servicing.

This machine should only be operated by a person with sufficient knowledge and skill to ensure safe operation.

High voltage circuits are located inside the output terminal cover and control panel.

- Close the cover and control panel before operating.

Moving parts and hot surfaces are contained within the enclosure.

- Close all doors and lock them before operating.

C25100000

P/N C255100004



P/N 0800520100

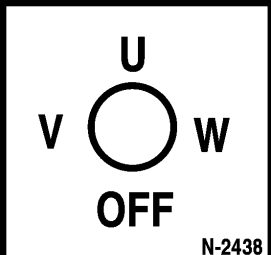

N-2438
P/N 0800520904

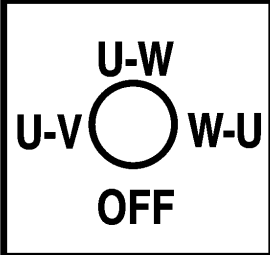

P/N 0800520814

WHISPERWATT 220



MQ POWER CORP.
WHISPERWATT 220
220 KVA AC GENERATOR
MODEL DCA-220SSK

C06110340

P/N C0561101603

CIRCUIT BREAKER
S-3031

P/N 08406 24504

PILOT LAMP
S-3033

P/N 0840624704

SETTING FOR OUTPUT VOLTAGE

(240V)

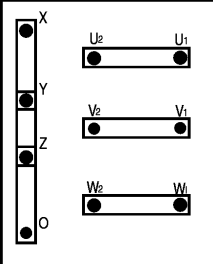

(480V)

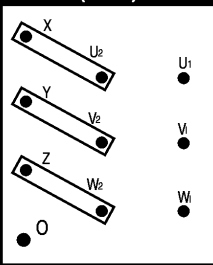

Tighten hexagon head bolts securely.

C0510000

P/N C0551000903

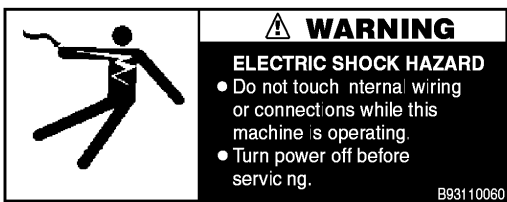

B93110060
P/N B9531100604

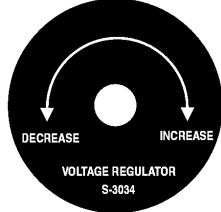

P/N 0840624804

ENGINE & RADIATOR GROUP

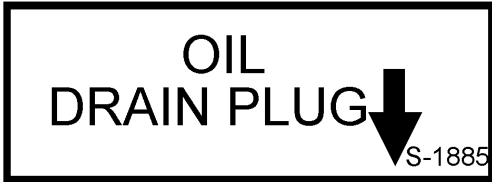

P/N 63606 20204



P/N 63606 10304

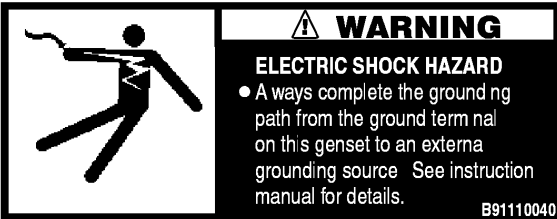

P/N B9511100404

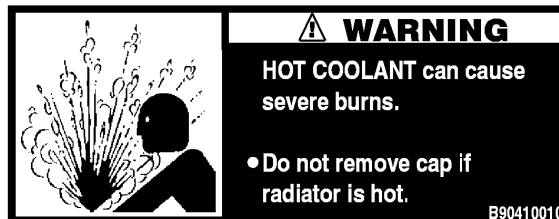

P/N B9504100104

ENGINE OPERATING PANEL GROUP



P/N 0840625004

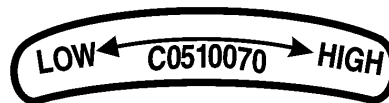

P/N C0551000704



P/N C0551000704



P/N C0551000804

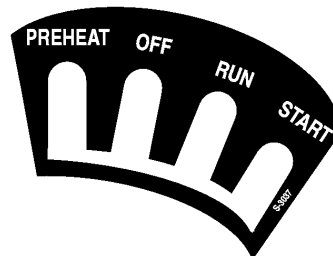

P/N 0840625104

ENGINE & RADIATOR GROUP

OUTPUT TERMINAL GROUP

GROUND

S-2635

P/N 0840614104

DANGER
HIGH VOLTAGE
S-2731

P/N 08040619904

240/139 VOLT

C15100040

P/N C1551000404



WARNING
ELECTRIC SHOCK HAZARD

- Do not touch output terminals while this machine is operating.
- Turn power off before servicing.

B93110050

P/N B9531100504



WARNING
ELECTRIC SHOCK HAZARD

- Always complete the grounding path from the ground terminal on this genset to an external grounding source. See instruction manual for details.

B91110040

P/N B9511100404

WARNING

- Before connecting this generator to any building's electrical system, a licensed electrician must install an isolation (transfer) switch.
- Serious injury or death may result without this transfer switch.

B91110030

P/N B9511100304

3-Phase output terminal
Keep the loads balancing when using plural single loads.

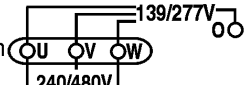

C05100040

P/N C0551000404

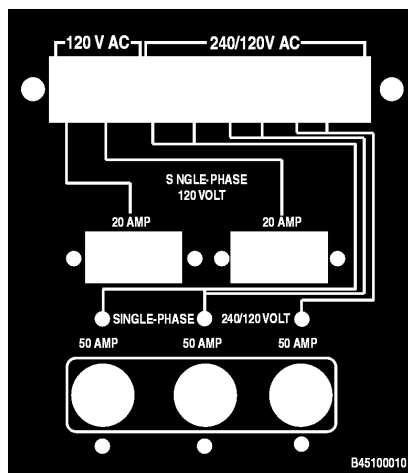

P/N B4551000103

BATTERY GROUP

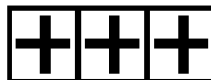

P/N 08006 89404

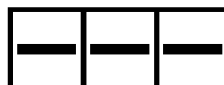

P/N 08006 89504

MUFFLER GROUP



WARNING

- Only operate machine in well ventilated areas.
- Do not inhale exhaust gases.

DANGEROUS GAS
Only qualified personnel should install, use, or service this equipment.

P/N B950420004

FUEL TANK GROUP



P/N 6360620004



P/N B9504500004



P/N 1320620904

ENCLOSURE GROUP

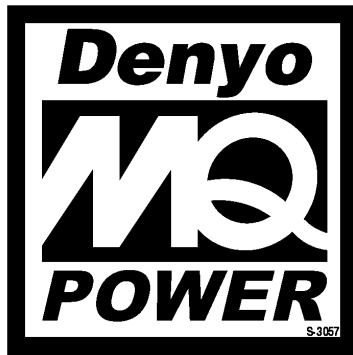

P/N 0840625902



P/N C0551000404

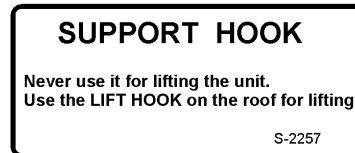

P/N 13206 21504

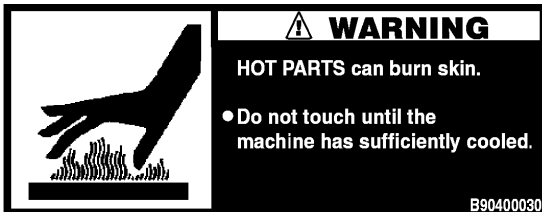

P/N B9504000304

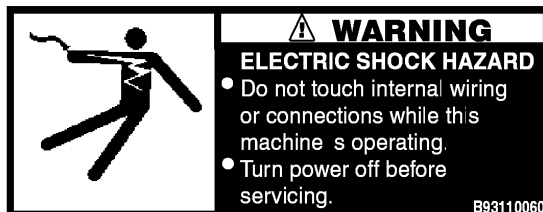

P/N B9531100604

DCA-220SSK SPECIFICATIONS

Table 7. Specifications					
Generator Specifications					
Model	DCA-220SSK				
Type	Revolving field, self ventilated, open protected type synchronous generator				
Armature Connection	Star with Neutral				
Phase	3				
Standby Output	242 KVA (193.6 KW)				
Prime Output	220 KVA (176 KW)				
Voltage	240V or 480V				
Frequency	60 Hz				
Speed	1800 rpm				
Power Factor	0.8				
Aux. AC Power	Single Phase, 60 Hz				
Voltage	120 V				
Output	4.8 KW (2.4 KW x 2)				
Engine Specifications					
Model	KOMATSU SA6D125E-2				
Type	4 Cycle, water-cooled, direct injection, turbo-charged				
No. of Cylinders	6 cylinders				
Bore x Stroke	4.9 in. x 5.9 in. (125 mm x 150 mm)				
Rated Output	273 HP/1800 rpm				
Displacement	671 cu. in. (11000 cc)				
Starting	Electric				
Coolant Capacity	11.1 gal. (42 liters)				
Lube Oil Capacity	10.4 gal. (40 liters)				
Fuel Consumption	<table border="1" style="width: 100%; border-collapse: collapse;"> <tr> <td style="text-align: center;">12.3 gal(46.6L)/hr at full load</td> <td style="text-align: center;">9.4 gal(35.6L)/hr at 3/4 load</td> </tr> <tr> <td style="text-align: center;">6.5gal(24.6L)/hr at 1/2 load</td> <td style="text-align: center;">4.0gal(15.1L)/hr at 1/4 load</td> </tr> </table>	12.3 gal(46.6L)/hr at full load	9.4 gal(35.6L)/hr at 3/4 load	6.5gal(24.6L)/hr at 1/2 load	4.0gal(15.1L)/hr at 1/4 load
12.3 gal(46.6L)/hr at full load	9.4 gal(35.6L)/hr at 3/4 load				
6.5gal(24.6L)/hr at 1/2 load	4.0gal(15.1L)/hr at 1/4 load				
Battery	12V- 150 AH x 2				
Fuel	#2 Diesel Fuel				

DCA-220SSK FAMILIARIZATION

Generator

The MQ Power Model DCA-220SSK is a 176 kW **generator** that is designed as a high quality portable (requires a trailer for transport) power source for telecom sites, lighting facilities, power tools, submersible pumps and other industrial and construction machinery.

Engine Control Panel

The "Engine Control Panel" is provided with the following:

- Tachometer
- Water Temperature Gauge
- Oil Pressure Gauge
- Charging Ammeter Gauge
- Engine Warning Lamp Module
- Engine Speed Switch
- Pre-Heat Button
- Pre-Heat Lamp
- Emergency Stop Button
- Battery Switch

Generator Control Panel

The "Generator Control Panel" is provided with the following:

- Output Voltage Adjustment Knob
- Frequency Meter (Hz)
- AC Ammeter (Amps)
- AC Voltmeter (Volts)
- Ammeter Change-Over Switch
- Voltmeter Change-Over Switch
- Panel Light
- Panel Light Switch
- MPEC Module
- Pilot Lamp

Output Terminal Panel

The "Output Terminal Panel" is provided with the following:

- Three 240/139V output receptacles, 50 amp
- Two 120V input receptacles, 20 amp
- 3 Load Circuit Breakers 265V @65 amps
- 2 Load GFCI Circuit Breakers 265V@ 20amps

Control Box

The "Control Box" is provided with the following:

- Main Circuit Breaker 600 amps
- Over-Current Relay
- High Idle Adjust Trimmer

Microprocessor Controlled Alarm System

The DCA-220SSK generator is equipped with various alarms and LED status indicators. These alarms and status indicators are provided to add safety to the generator when operating under normal conditions. The DCA-220SSK generator is designed to shutdown in the event of low oil, high coolant temperature, low battery and other operation conditions that may cause severe damage to the generator.

Open Delta Excitation System

The DCA-220SSK generator is equipped with the state of the art "**Open-Delta**" excitation system. The open delta system consist of an electrically independent winding wound among stationary windings of the AC output section.

There are four leads: A, B, C and D. During light loads, the power to the **Automatic Voltage Regulator (AVR)** is supplied from the leads parallel connections of B&C. When loads increase, the AVR switches and accepts power from leads A&D. The output of leads A&D increase proportionally with load. This of adding the voltages to each phase provides better voltage response during heavy loads.

The connections of the AVR to the AC output windings are for sensing only. No power is required from these windings.

The open-delta design provides virtually unlimited excitation current, offering maximum motor starting capabilities. The excitation does not have a "**fixed ceiling**" and responds according the demands of the required load.

Engine

The **DCA-220SSK** is powered by a 4 cycle, water cooled, turbocharged KOMATSU Model SA6D125E-2 *diesel* engine. This engine is designed to meet every performance requirement for the generator. Reference Table 7, page 26 for engine specifications.

In keeping with Multiquip's policy of constantly improving its products, the specifications quoted herein are subject to change without prior notice.

The basic controls and indicators for the DCA-220SSK generator are addressed on the following pages.

Electronic Governor System

The electronic governor system replaces the standard mechanical governor system. The frequency regulation improves from $\pm 3.0\%$ regulation with the mechanical governor to $\pm 0.25\%$ regulation with the electronic governor system.

Jacket Water Heater

The jacket water heater is a 1500-watt heater designed to keep the coolant warm in the engine block for fast starts and load acceptance. The heater is thermostatically controlled and once an acceptable engine temperature is achieved it will cycle on and off, operating only about 1/3 of the time, which makes it more efficient than the direct block type heater. It is designed to keep the engine coolant between 100 and 120 degrees fahrenheit.

Under normal conditions, 20 to 15 minutes is required to raise the engine temperature of a cold engine to 100 degrees fahrenheit.

CAUTION :



ALWAYS unplug the jacket water heater before servicing.

Battery Charger

The battery charger will operate in a 'BOOST' mode until the battery's current acceptance falls to 70% of the charger's rating. The charger will then go into a 'FLOAT' mode, where it discharges a lower voltage until an AC failure, or the battery is discharged.

NOTE:

The jacket water heater can be serviced if not functioning properly.

DCA-220SSK — WATER SEPARATOR FILTER

Water Separator Filter

The DCA-220SSK generator is equipped with a “Water Fuel Separator. This unit is designed to prevent dirt, rust, algae, varnishes and water from entering the fuel system.

This water separator system is designed around two filters connected in parallel (Figure 6). These two filters can be configured in a variety of ways to filter water from the fuel system.

For best results it is best to have both filters active (ON) at the same time or use only one filter, and use the other filter as a reserve, that way you can use the filters alternately every time the filter element is replaced.

CAUTION:

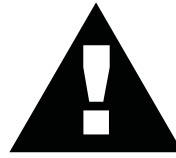

DO NOT turn the control valve while the generator is in operation. This may stop fuel flow to the generator if both filters are set to the OFF position.

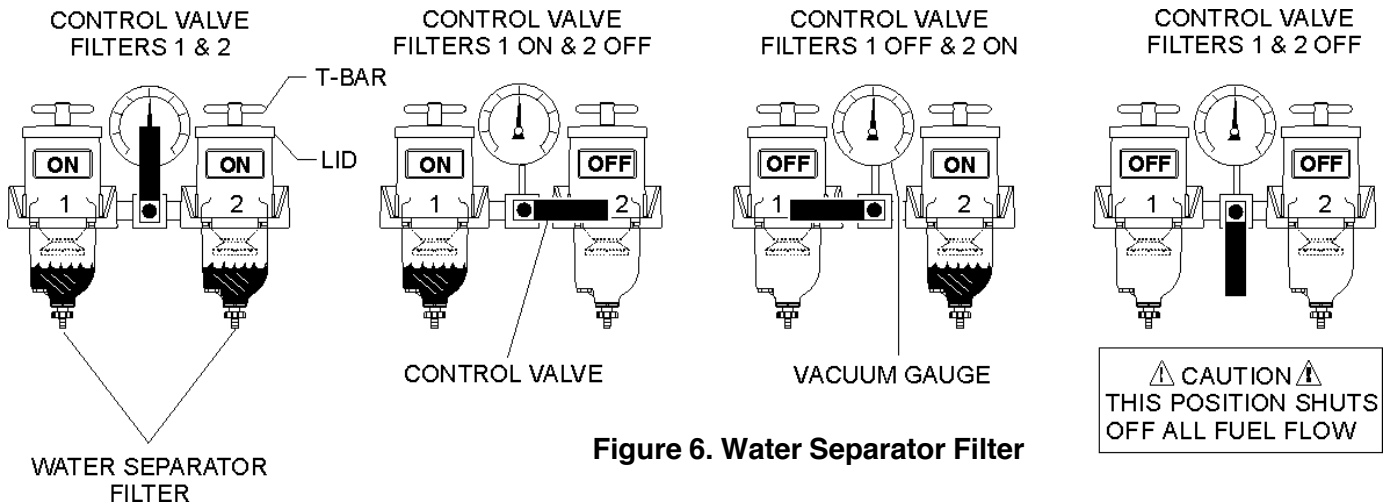

Figure 6. Water Separator Filter

Collection Bowl Water Drainage

Inspect or drain the water in the collection bowl daily. The collection bowl must be drained before contaminants reach the bottom of the turbine.

To drain the collection bowl perform the following:

1. Open the self-venting drain to evacuate contaminants with a suitable collection container in place.
2. Prime the unit by removing the filter lid and filling with clean fuel.
3. Replace the filter lid and snugly tighten the T-handle by hand only.

DCA-220SSK — MAJOR COMPONENTS

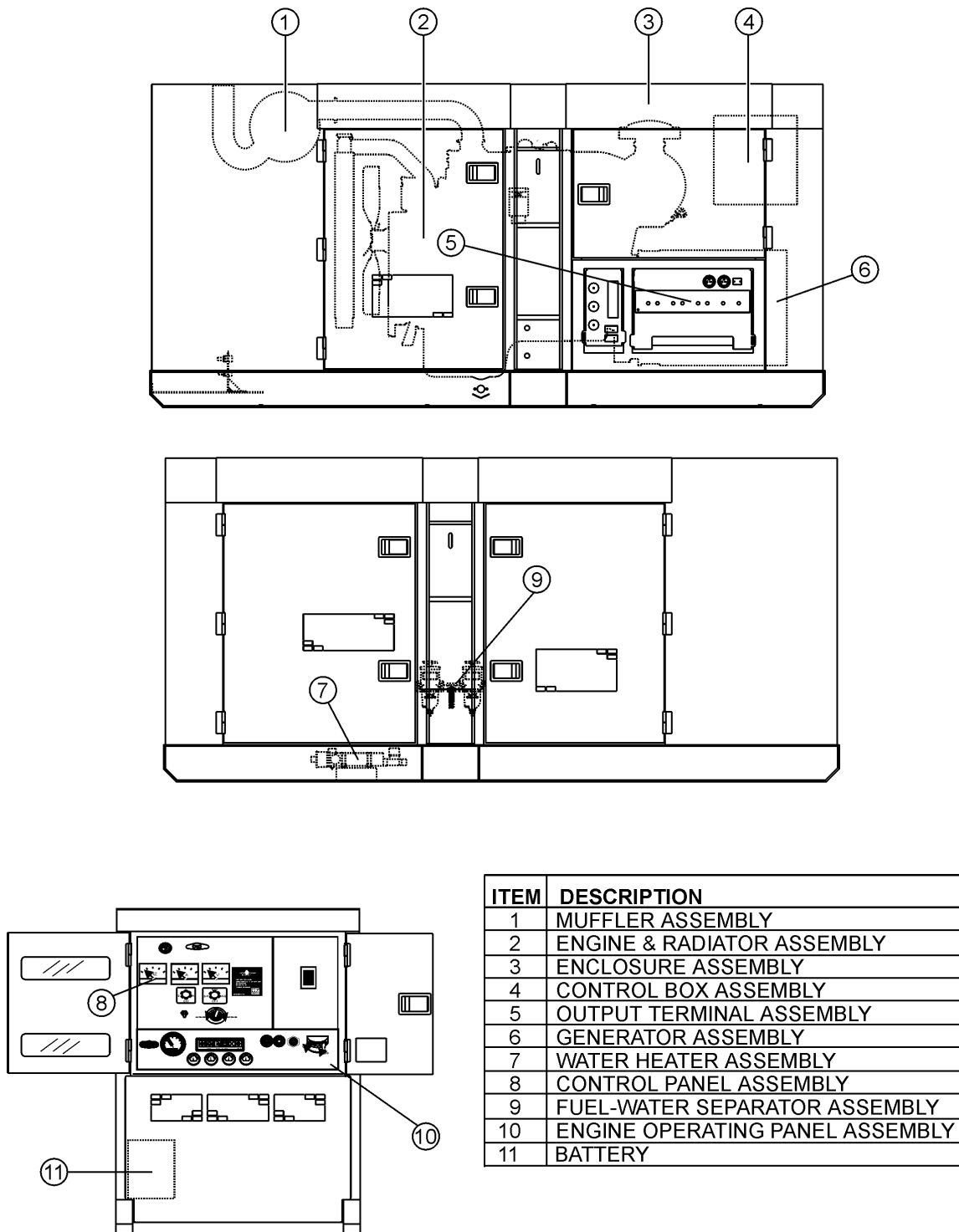
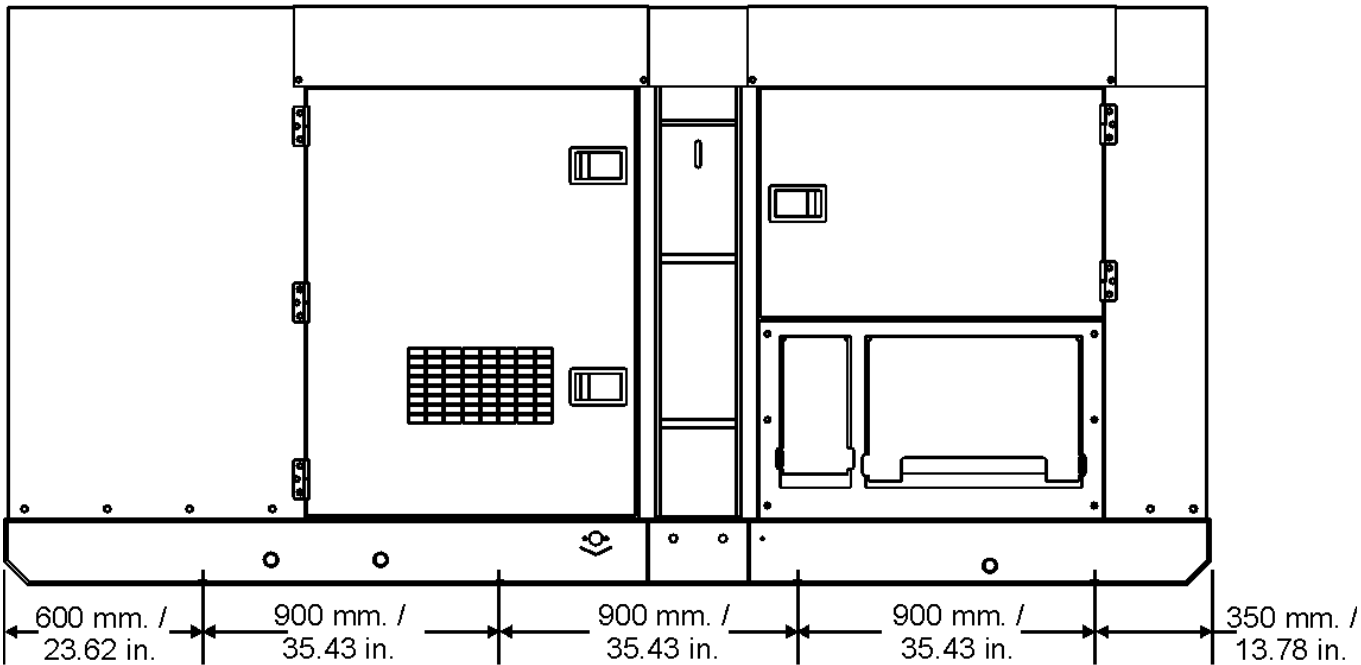

Figure 7. Major Components

DCA-220SSK — DIMENSIONS (TOP AND SIDE)

SIDE VIEW



(BOLT HOLE LOCATION)

TOP VIEW

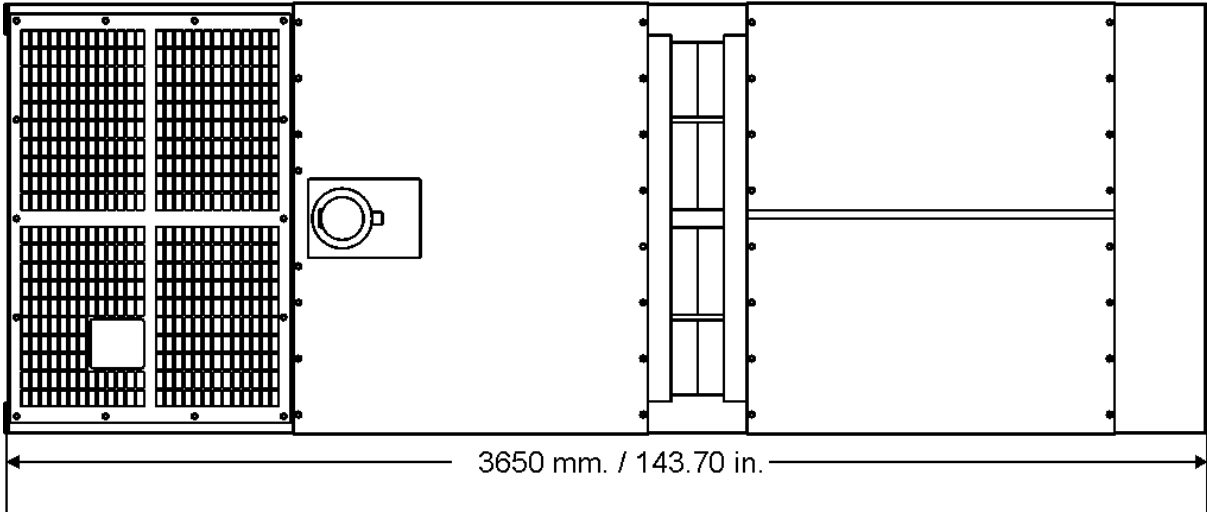

Figure 8a. Dimensions

DCA-220SSK — DIMENSIONS (FRONT AND REAR)

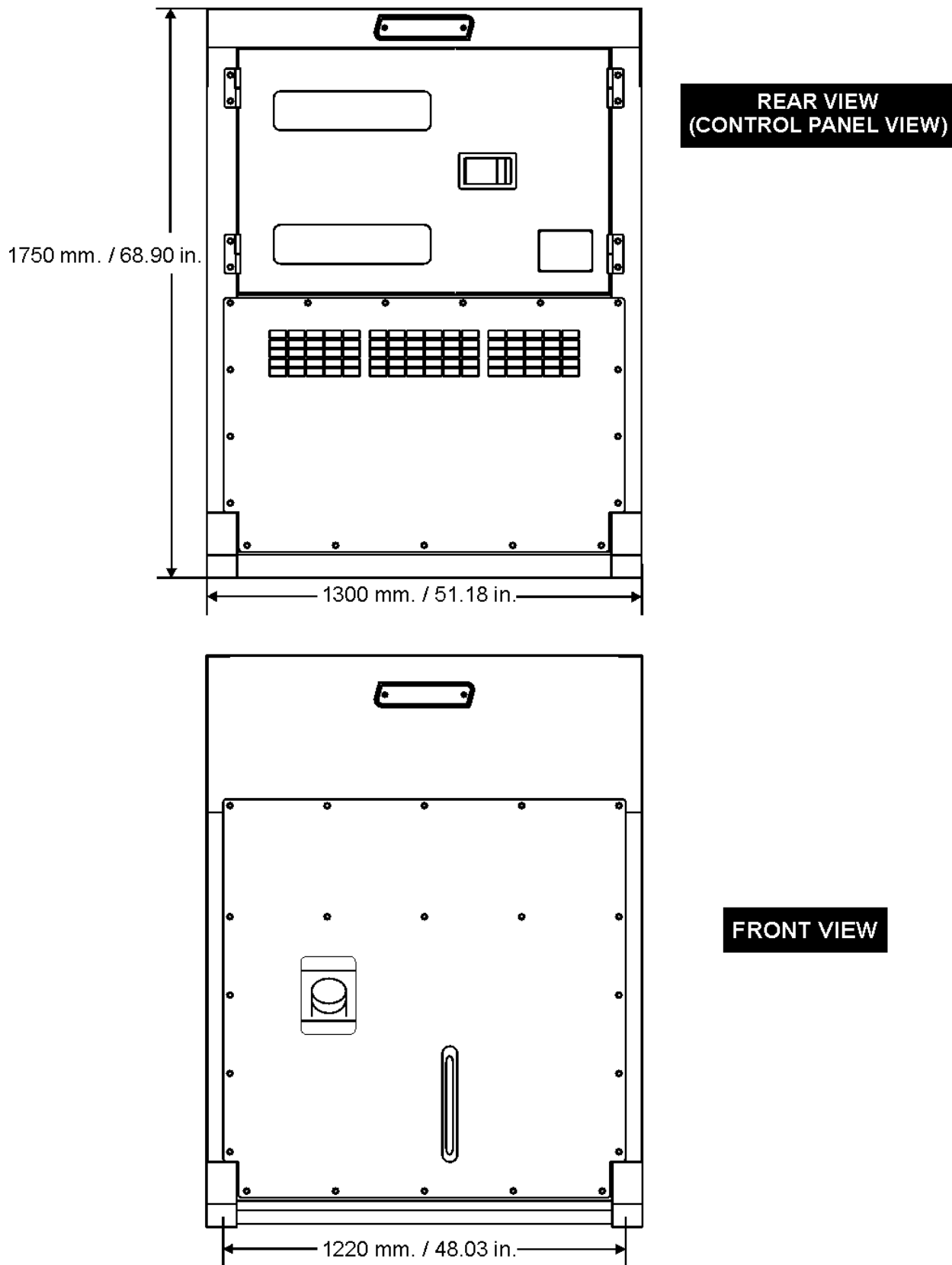
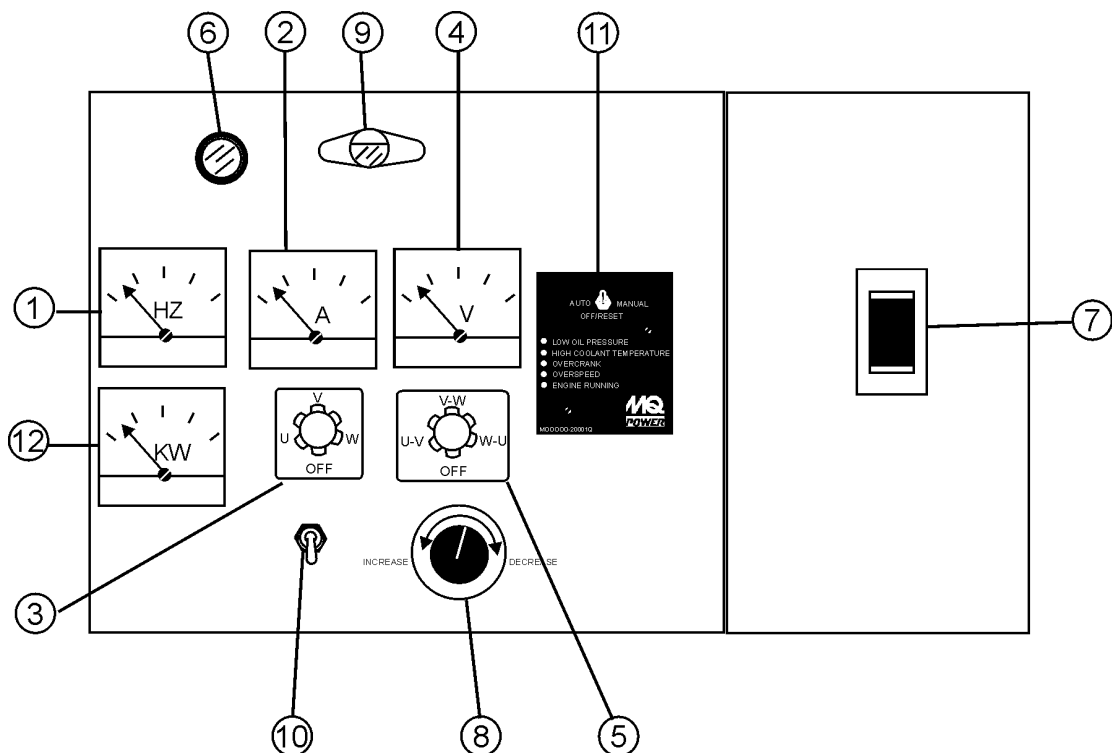

Figure 8b. Dimensions



1	FREQUENCY METER
2	AC AMMETER
3	AMMETER CHANGE-OVER SWITCH
4	AC VOLTMETER
5	VOLTMETER CHANGE-OVER SWITCH
6	PILOT LAMP
7	CIRCUIT BREAKER
8	VOLTAGE REGULATOR
9	PANEL LIGHT
10	PANEL LIGHT SWITCH
11	MICROPROCESSOR ENGINE CONTROLLER
12	KILOWATT METER

Figure 9. Control Panel

The definitions below describe the controls and functions of the DCA-220SSK " **Control Panel** "(Figure 9).

1. **Frequency Meter** – Indicates the output frequency in hertz (Hz). Normally 60 Hz ±1 Hz .
2. **AC Ammeter** – Indicates the amount of current the load is drawing from the generator.
3. **Ammeter Change-Over Switch** – This switch allows the AC ammeter to indicate the current flowing to the load connected to any phase of the output terminals, or to be switched off.
4. **AC Voltmeter** – Indicates the single phase output voltage present at the UNV terminals.
5. **Voltmeter Change-Over Switch** – This switch allows the AC voltmeter to indicate phase to phase voltage between any two phases of the output terminals or to be switched off.
6. **Pilot Lamp** – Indicates that the generator is working properly.
7. **Main Circuit Breaker** – This three-pole, 600 amp main breaker is provided to protect the UNV voltage output terminals from overload.
8. **Voltage Regulator Control** – Allows manual adjustment of the generator's output voltage.
9. **Panel Light** – Normally used in dark areas or at night time. When activated, panel lights will illuminate. When the generator is not in use be sure to turn the panel light switch to the OFF position.
10. **Panel Light Switch** – When activated will turn on control panel light.

11. **MPEC – Microprocessor Engine Control Module** – (MPEC) has a vertical row of status LED's (Figure 10), that when lit, indicate that an engine malfunction (fault), has been detected.



Figure 10. MPEC Module

When a fault has been detected the MPEC will evaluate the fault and all major faults will shutdown the generator.

During **cranking cycle** , The MPEC will attempt to crank the engine for 10 seconds before disengaging. If the

engine does not engage (start) by the third attempt, the engine will be shut-down by the MPEC's " Over Crank Protection" mode. If the engine engages at a speed (RPM's) that is not safe, the MPEC will shut-down the engine by initializing the "Over Speed Protection" mode.

Also the MPEC will shut-down the generator in the event of low oil pressure, high coolant temperature, low coolant level, and loss of magnetic pickup. These conditions can be observed by monitoring the LED status indicators on the front of the MPEC module.

- A. **Off/Manual/Auto Switch** – This switch controls the running of the generator. If this switch is left in the "OFF" position, the generator will not run. When this switch is set to the **manual** position, the generator will start immediately.

If the generator is to be connected to a building's AC power source via a transfer switch (isolation), place the switch in the **auto** position. In this position the generator will monitor the AC line output from the building's power source.

- B. **Low Oil Pressure** – Indicates the engine pressure has fallen below 15 psi. The oil pressure is detected using variable resistive values from the oil pressure sending unit. This is considered a **major** fault.
- C. **High Coolant Temperature** – Indicates the engine temperature has exceeded 215°F. The engine temperature is detected using variable resistive values from the temperature sending unit. This is considered a **major** fault.
- D. **Overcrank Shutdown** – Indicates the unit has attempted to start a pre-programmed number of times, and has failed to start. The number of cycles and duration are programmable. It is pre-set at 3 cycles with a 10 second duration. This is considered a **major** fault.
- E. **Overspeed Shutdown** – Indicates the engine is running at an unsafe speed. This is considered a **major** fault.
- F. **Engine Running** – Indicates that engine is running at a safe operating speed.
12. **Kilowatt Meter** - Indicat's the output power of the generator.
13. **High Idle Adjust Trimmer** - Used to adjust the engine speed.

DCA-220SSK — ENGINE OPERATING PANEL

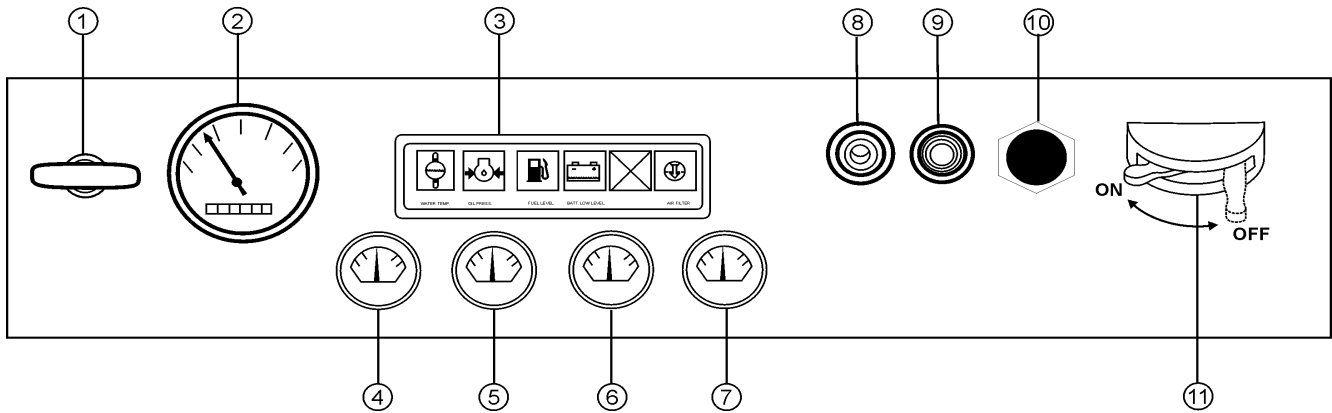

NO.	NAME
1	THROTTLE HANDLE
2	TACHOMETER
3	ENGINE WARNING DISPLAY LED
4	OIL PRESSURE GAUGE
5	WATER TEMPURATURE GAUGE
6	CHARGING AMMETER
7	FUEL LEVEL GAUGE
8	PREHEAT LAMP
9	PREHEAT BUTTON
10	EMERGENCY STOP BUTTON
11	BATTERY SWITCH

Figure 11. Engine Operating Panel

DCA-220SSK — ENGINE OPERATING PANEL

The definitions below describe the controls and functions of the DCA-220SSK " **Engine Operating Panel** "(Figure 11).

1. **Throttle Handle** - This handle controls the speed of the engine (low or high).
2. **Tachometer** – Indicates engine speed in RPM's for 60 Hz operation. This meter should indicate 1800 RPM's when the rated load is applied. In addition a built in hour meter will record the number of operational hours that the generator has been in use.
3. **Engine Warning Display Module** – This module display's the following engine failures:

A. **Overheat Lamp** – This lamp goes ON when the cooling water temperature rises abnormally. If the lamp goes ON during normal operation of the generator, the emergency shut-down device will stop the engine automatically.

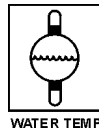

B. **Low Oil Pressure Lamp** – During normal operation of the generator this lamp should remain OFF. When the Auto-OFF/Reset-Manual switch is set to the "Manual" position to start the engine, the lamp will be lit. After the oil pressure rises after start-up the lamp will go OFF. If this lamp is ever lit (ON) during normal operation of the generator, the emergency shut-down device will stop the engine automatically.

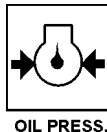

C. **Low Fuel Level Lamp** – When this lamp is ON, it is time to stop the engine and add fuel. Remember to let the engine cool before adding fuel.

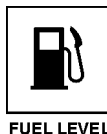

D. **Low Battery Fluid Lamp** – This lamp goes ON when the battery fluid is low. If this lamp goes ON during normal operation of the generator, stop the engine and fill the battery with distilled water to the specified level.

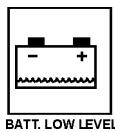

E. **Clogged Air Filter Lamp** – This lamp goes ON when the air filter is clogged. If this lamp goes ON during normal operation of the generator, stop the engine and replace the air filter.

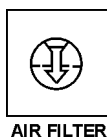

4. **Oil Pressure Gauge** – During normal operation this gauge be should read in the "GREEN" zone. When starting the generator the oil pressure mar read a little bit higher, but after the engine warms up the oil pressure should return to the green zone.

5. **Water Temperature Gauge** – During normal operation this gauge be should read in the "GREEN" zone.

6. **Charging Ammeter Gauge** – Indicates the current being supplied by the engine's alternator which provides current for generator's control circuits and battery charging system.

7. **Fuel Gauge** - Indicates amount of diesel fuel available.

8. **Pre-Heat Lamp** – Indicates that the glow plugs of the diesel engine are hot and the engine is ready to be started.



9. **Pre-Heat Button** – Press hold this button until the pre-heat lamp is lit (ON).



10. **Emergency Stop Button** – Push this button inward to stop the engine in the event of an emergency. **DO NOT** use this button as a means of stopping the engine.



11. **Battery Switch** – This switch should be set to the ON position during normal operation. When the engine has been stop, place this switch in the OFF position. **DO NOT** turn this switch during normal operation, it could cause damage to the electrical equipment.

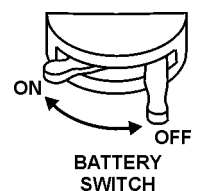

DCA-220SSK — OUTPUT TERMINAL PANEL

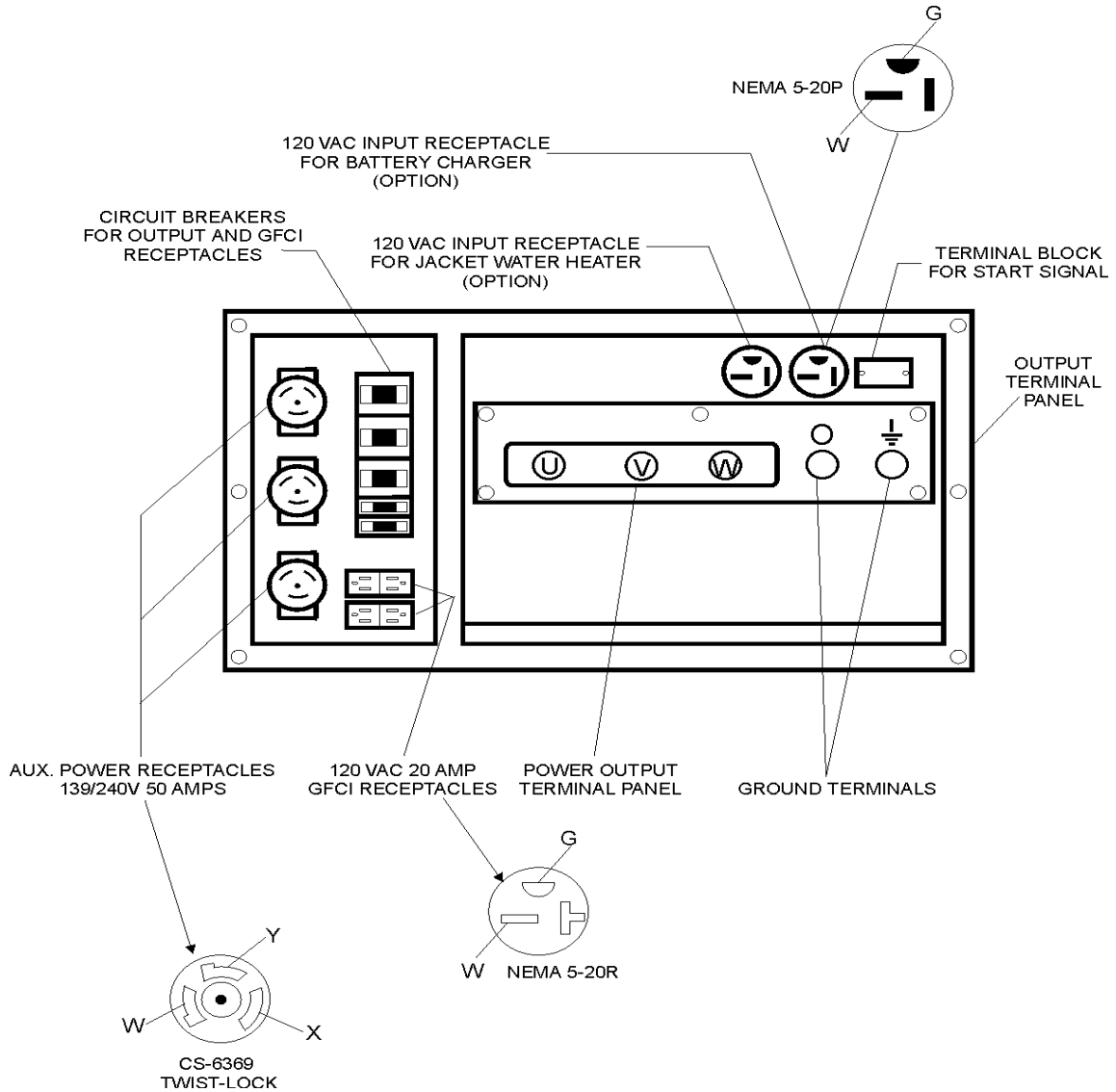
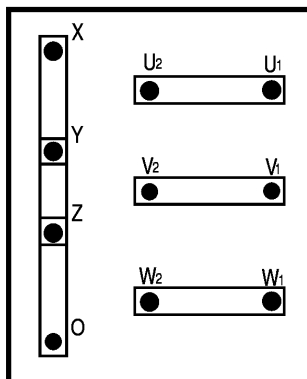

Figure 12. Output Terminal Panel

DCA-220SSK — OUTPUT TERMINAL VOLTAGE SELECTION

VOLTAGE CHANGE-OVER BOARD, 240V SET



VOLTAGE CHANGE-OVER BOARD, 480V SET

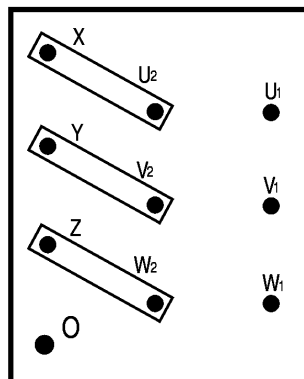

OUTPUT TERMINALS
3-PHASE, 240V

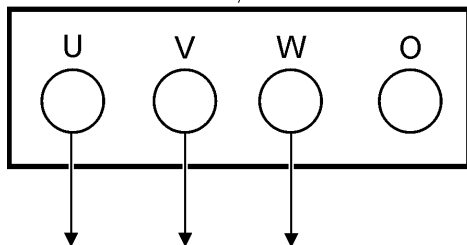

OUTPUT TERMINALS
3-PHASE, 480V

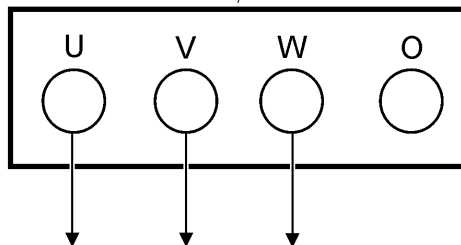

OUTPUT TERMINALS
2-PHASE, 240V

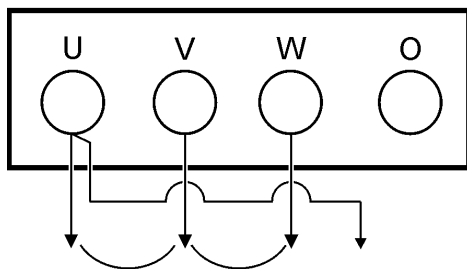

OUTPUT TERMINALS
2-PHASE, 480V

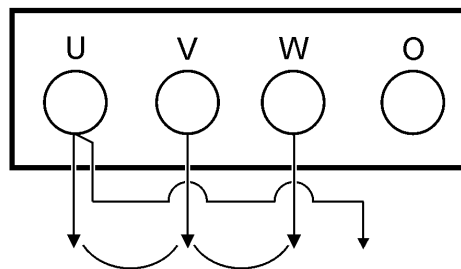

OUTPUT TERMINALS
SINGLE PHASE, 139V

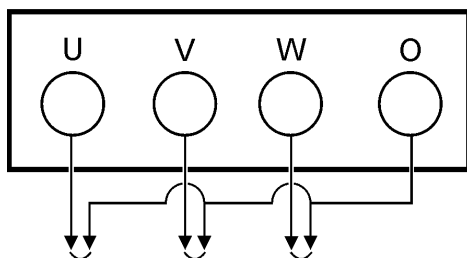

OUTPUT TERMINALS
SINGLE PHASE, 277V

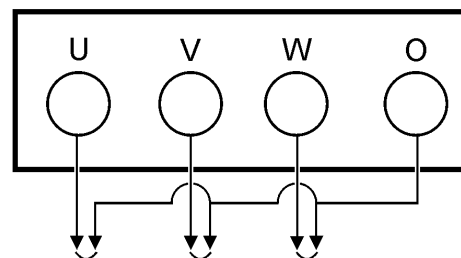

Figure 13. Output Terminal Voltage Selection

Outdoor Installation

Install the generator in a location where it will not be exposed to rain or sunshine. Make sure the generator is on secure level ground so it cannot slide or shift around. Also install the generator so the exhaust will not be discharged in the direction of nearby homes.

The installation site must be relatively free from moisture and dust. All electrical equipment should be protected from excessive moisture. Failure to do will result in deterioration of the insulation and will result in short circuits and grounding.

Foreign materials such as dust, sand, lint and abrasive materials have a tendency to cause excessive wear to the engine parts and alternator.

CAUTION :



Pay close attention to ventilation when operating the generator inside tunnels and caves. The engine exhaust contains noxious elements. Engine exhaust must be routed to a ventilated area.

Indoor Installation

Exhaust gases from diesel engines are extremely poisonous. Whenever an engine is installed indoors the exhaust fumes must be vented to the outside. The engine should be installed at least two feet from any outside wall. Using an exhaust pipe which is too long or too small can cause excessive back pressure which will cause the engine to heat excessively and possibly burn the valves.

CAUTION :

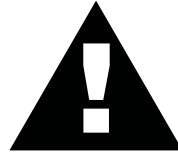

An electric shock may happen when vibrators are used. Pay close attention to handling when operating vibrators and always use rubber boots and gloves to insulate the body from electrical shock.

Generator Grounding

To guard against electrical shock and possible damage to the equipment, it is important to provide a good **EARTH** ground.

Article 250 (Grounding) of the National Electrical Code (NEC) provides guide lines for proper grounding and specifies that the cable ground shall be connected to the grounding system of the building as close to the point of cable entry as practical.

NEC articles 250-64(b) and 250-66 set the following grounding requirements:

1. Use one of the following wire types to connect the generator to earth ground.
 - a. Copper - 10 AWG (5.3 mm²) or larger.
 - b. Aluminum - 8 AWG (8.4 mm²) or larger.
2. When grounding the generator (Figure 14) connect the ground cable between the lock washer and the nut on the generator and tighten the nut fully. Connect the other end of the ground cable to earth ground.
3. NEC article 250-52(c) specifies that the earth ground rod should be buried a minimum of 8 ft. into the ground.

NOTE

When connecting the generator to any buildings electrical system **ALWAYS** consult with a licensed electrician.

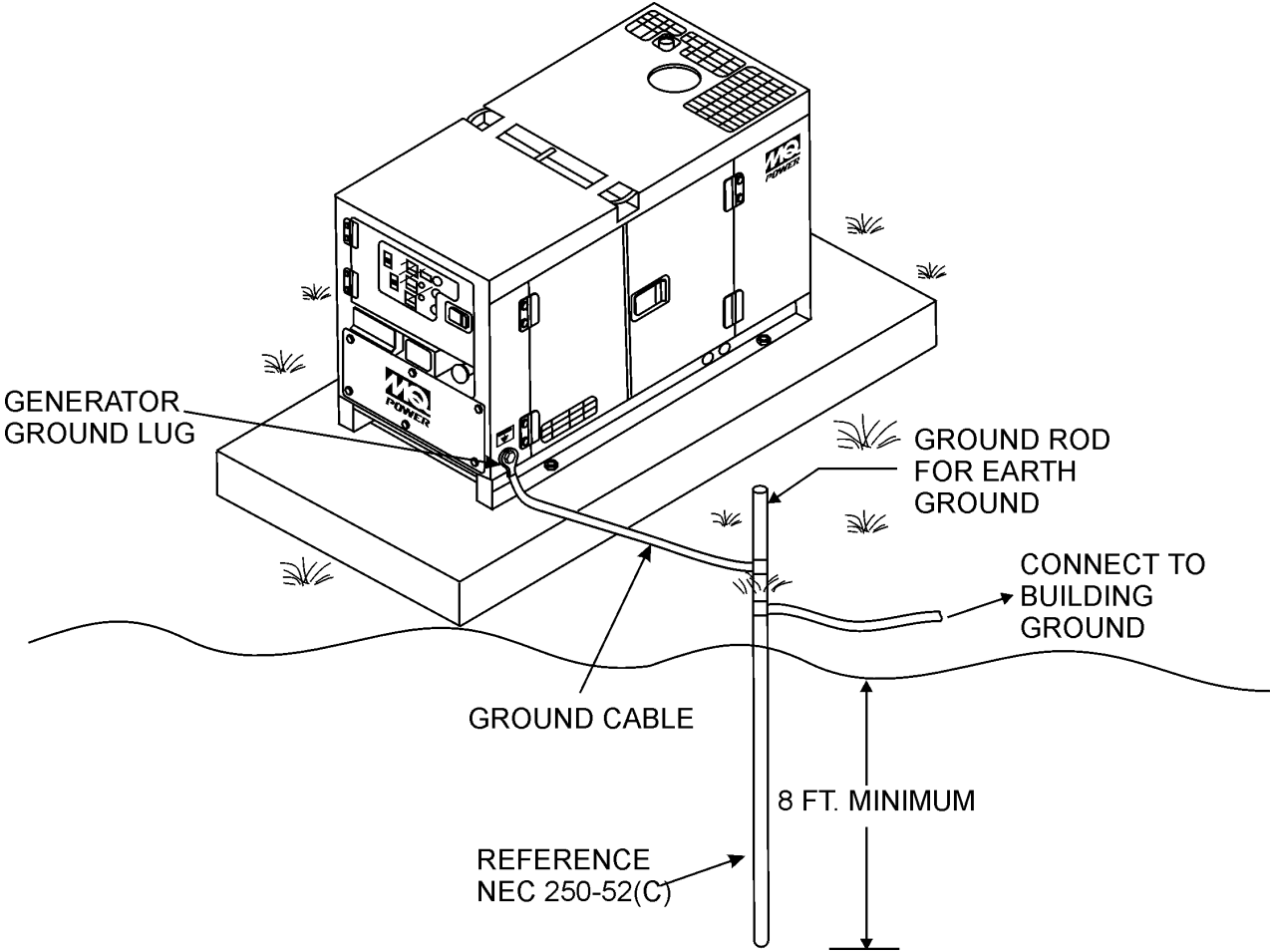

Figure 14. Typical Generator Grounding Application

General Inspection Prior to Operation

The DCA-220SSK generator has been thoroughly inspected and accepted prior to shipment from the factory. However, be sure to check for damaged parts or components, or loose nuts and bolts, which could have occurred in transit.

Extension Cable

When electric power is to be provided to various tools or loads at some distance from the generator, extension cords are normally used. Cables should be sized to allow for distance in length and amperage so that the voltage drop between the generator and point of use (load) is held to a minimum. Use the Cable Selection Guide (Table 8) as a guide for selecting proper cable size.

Circuit Breakers

To protect the generator from an overload, a 3-pole, 600 amp, **main** circuit breaker is provided to protect the UNV output terminals from overload. In addition two single-pole, 20 amp **GFCI** circuit breakers are provided to protect the GFCI receptacles from overload. Three 50 amp **load** circuit breakers have also been provided to protect the load side of the generator from overload. Make sure to switch **ALL** circuit breakers to the "OFF" position prior to starting the engine.

NOTE

ALWAYS consult with a licensed electrician for correct extension cord wire size.

Table 8. Cable Selection (60 Hz, Single Phase Operation)

Current in Amperes	Load In Watts		Maximum Allowable Cable Length			
	At 120 Volts	At 240 Volts	#10 Wire	#12 Wire	#14 Wire	#16 Wire
2.5	300	600	1000 ft.	600 ft.	375 ft.	250 ft.
5	600	1200	500 ft.	300 ft.	200 ft.	125 ft.
7.5	900	1800	350 ft.	200 ft.	125 ft.	100 ft.
10	1200	2400	250 ft.	150 ft.	100 ft.	
15	1800	3600	150 ft.	100 ft.	65 ft.	
20	2400	4800	125 ft.	75 ft.	50 ft.	

CAUTION: Equipment damage can result from low voltage.

Lubrication Oil

Fill the engine crankcase with lubricating oil through the filler hole, but do not overfill. Make sure the generator is level. With the dipstick inserted all the way, but without being screw into the filler hole, verify the oil level is maintained between the two notches (Figure 15) on the dipstick. See Table 9 for proper selection of engine oil.

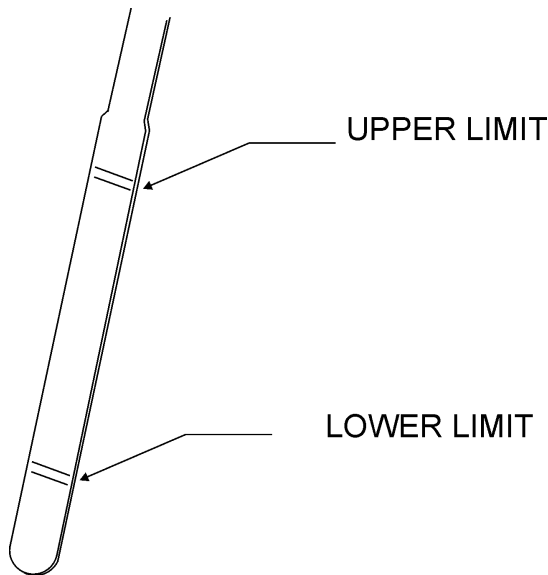

Figure 15. Engine Oil Dipstick

When checking the engine oil, be sure to check if the oil is clean and viscous. If the oil is not clean, drain the oil by removing the oil drain plug, and refill with the specified amount of oil as outlined in the **Komatsu Engine Owner's Manual**.

Fuel

Fill the fuel tank with clean and fresh **diesel fuel**. **DO NOT** fill the tank beyond capacity.

Pay attention to the fuel tank capacity when replenishing fuel. Refer to the fuel tank capacity listed on page 25, Specification Table 7.

The fuel tank cap must be closed tightly after filling. Handle fuel in a safety container. If the container does not have a spout, use a funnel. Wipe up any spilled fuel immediately.

CAUTION:

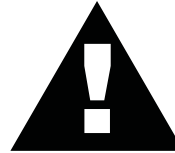

Never fill the fuel tank while the engine is running or in the dark. Diesel spillage on a hot engine can cause a fire or explosion. If diesel spillage occurs, wipe up the spilled diesel completely to prevent fire hazards.

Coolant

Use only drinkable tap water. If hard water or water with many impurities is used, the inside of the engine and radiator may become coated with deposits and cooling efficiency will be reduced.

An anticorrosion additive added to the water will help prevent deposits and corrosion in the cooling system. See the engine manual for further details.

Table 9. Recommended Motor Oil

Temperature Range	Type Oil
104° F ~ 23° F (40° C ~ -5° C)	SAE 30
23° F ~ 5° F (-5° C ~ -15° C)	SAE 20 or SAE 10W-30
Below 5° C (-15°)	SAE 10W or SAE 10W-30

CAUTION :



When adding coolant or antifreeze to the radiator, do not remove the radiator cap until the unit has completely cooled.

Day-to-day addition of coolant is done from the reserve tank. When adding coolant to the radiator, **DO NOT** remove the radiator cap until the unit has completely cooled. See Table 10 for engine, radiator, and reserve tank coolant capacities. Make sure the coolant level in the reserve tank is always between the "H" and the "L" markings.

Table 10. Coolant Capacity

Engine and Radiator	11.1 Gal. (42.0 Liters)
Reserve Tank	2 Quarts (1.9 Liters)

Operation in Freezing Weather

When operating in freezing weather, be certain the proper amount of antifreeze (Table 11) has been added.

Table 11. Anti-Freeze Operating Temperatures

Vol % Anti-Freeze	Freezing Point		Boiling Point	
	°C	°F	°C	°F
40	-24	-12	106	222
50	-37	-34	108	226

NOTE

When the anti-freeze is mixed with water, the anti-freeze mixing ratio must be less than 50%.

Cleaning the Radiator

The engine may overheat if the radiator fins become overloaded with dust or debris. Periodically clean the radiator fins with compressed air. Cleaning inside the machine is dangerous, so clean only with the engine turned off and the battery disconnected.

Air Cleaner

Periodic cleaning/replacement is necessary. Inspect it in accordance with the **Komatsu Engine Owner's Manual**.

Fan Belt Tension

A slack fan belt may contribute to overheating, or to insufficient charging of the battery. Inspect the fan belt for damage and wear and adjust it in accordance with the **Komatsu Engine Owner's Manual**.

The fan belt tension is proper if the fan belt bends 7 to 10 mm (Figure 16) when depressed with the thumb as shown below.

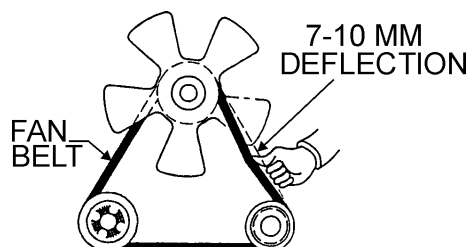

Figure 16. Fan Belt Tension

CAUTION :



Never place hands near the belts or fan while the generator set is running.

Battery

This unit is of negative ground. **DO NOT** connect in reverse. Always maintain battery fluid level between the specified marks. Battery life will be shortened, if the fluid level is not properly maintained. Add only distilled water when replenishment is necessary.

The battery is sufficiently charged if the specific gravity of the battery fluid is 1.28 (at 68° F). If the specific gravity should fall to 1.245 or lower, it indicates that the battery is dead and needs to be recharged or replaced.

Check to see whether the battery cables are loose. Poor contact may result in poor starting or malfunctions. Always keep the terminals firmly tightened. Coating the terminals with a thin film of grease will help to inhibit corrosion.

Battery Cable Installation

ALWAYS be sure the battery cables (Figure 17) are properly connected to the battery terminals as shown below. The **RED** cable is connected to the positive terminal of the battery, and the **BLACK** cable is connected to the negative terminal of the battery.

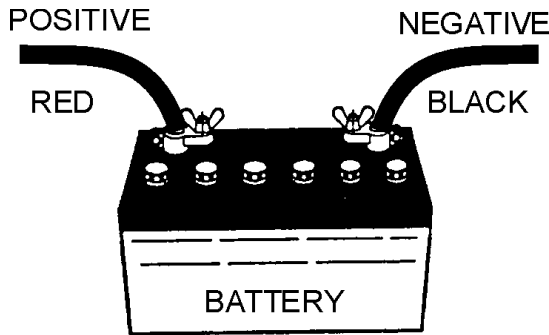

Figure 17. Battery Connections

CAUTION :



Inadequate battery connections may cause poor starting of the generator, and create other malfunctions.

Wiring

Inspect the entire generator for bad or worn electrical wiring or connections. If any wiring or connections are exposed (insulation missing) replace wiring immediately.

Piping and Hose Connection

Inspect all piping, oil hose, and fuel hose connections for wear and tightness. Tighten all hose clamps and check hoses for leaks.

If any hose (fuel or oil) lines are defective replace them immediately.

CAUTION :



If the battery cable is connected incorrectly, electrical damage to the generator will occur. Pay close attention to the polarity of the battery when connecting the battery.

When connecting battery do the following:

1. **DO NOT** connect the battery cables to the battery terminals when the **Off/Manual/Auto** switch is in either the manual or auto position (ON). **ALWAYS** make sure that the Off/Manual/Auto switch is in the OFF position when connecting the battery..
2. Place a small amount of grease around both battery terminals. This will ensure a good connection and will help prevent corrosion around the battery terminals.

Single Phase Load

Always be sure to check the nameplate on the generator and equipment to insure the wattage, amperage and frequency requirements are satisfactorily supplied by the generator for operating the equipment.

Generally, the wattage listed on the nameplate of the equipment is its rated output. Equipment may require 130—150% more wattage than the rating on the nameplate, as the wattage is influenced by the efficiency, power factor and starting system of the equipment.

NOTE

If wattage is not given on the equipment's name plate, approximate wattage may be determined by multiplying nameplate voltage by the nameplate amperage.

$$\text{WATTS} = \text{VOLTAGE} \times \text{AMPERAGE}$$

The power factor of this generator is 1.0. See Table 12. below when connecting loads.

Table 12. Power Factor By Load

Type Of Load	Power Factor
Single-phase induction motors	0.4 - 0.75
Electric heaters, incandescent lamps	1.0
Fluorescent lamps, mercury lamps	0.4 - 0.9
Electronic devices, communication equipment	1.0

Three Phase Load

When calculating the power requirements for 3-phase power use the following equation:

$$\text{KVA} = \frac{\text{VOLTAGE} \times \text{AMPERAGE} \times \sqrt{3}}{1000}$$

CAUTION:



Motors and motor-driven equipment draw much greater current for starting than during operation.

An inadequate size connecting cable which cannot carry the required load can cause a voltage drop which can burn out the appliance or tool and overheat the cable.

- When connecting a resistance load such as an incandescent lamp or electric heater, a capacity of up to the generating set's rated output (kW) can be used.
- When connecting a fluorescent or mercury lamp, a capacity of up to the generating set's rated output (kW) multiplied by 0.6 can be used.
- When connecting an electric drill or other power tools, pay close attention to the required starting current capacity.

When connecting ordinary power tools, a capacity of up to the generating set's rated output (kW) multiplied by 0.8 can be used.

CAUTION:



Before connecting this generator to any building's electrical system, a licensed electrician must install an isolation (transfer) switch. Serious injury or death may result without this transfer switch.

NOTE

If output (kVA) is not given on the equipment nameplate, approximate output may be determined by multiplying voltage by amperage by $\sqrt{3}$.

WARNING:



The engine's exhaust contains harmful emissions. **ALWAYS** ventilate the exhaust when operating inside tunnels, excavations or buildings. Direct exhaust away from nearby personnel.

Before Starting Engine

1. Check the lubricating oil level prior to starting the engine. Make sure the generator is level. The oil level must be maintained between two notches on the dipstick.
2. When there is not enough lubricating oil, fill the crankcase with high grade motor oil. Use a high quality detergent oil classified CC or higher (See Table 9 on page 41).
3. Check the coolant level in the radiator and subtank. Replenish with antifreeze as necessary. Always maintain the coolant level between the **FULL** and **LOW** markings on the coolant container. Be sure that the radiator cap is fastened securely.
4. Check the fuel level on the fuel gauge. If fuel is low, fill the fuel tank with clean fresh unleaded automotive diesel. If diesel spillage occurs, completely wipe up the spilled fuel immediately.

Before Starting

Generator and Control Panel

CAUTION:



NEVER start the engine with the *main*, *GFCI* or *load* circuit breakers in the **ON** position.

1. Be sure to disconnect the electrical load and switch the *main*, *load* and *G.F.C.I.* circuit breakers (Figure 18) to the "OFF" position prior to starting the engine.

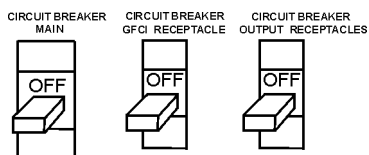

Figure 18. Main, GFCI and Load Circuit Breakers

Jacket Water Heater and Internal Battery Charger 120 VAC Output Receptacles

This generator is equipped with two 120 VAC, 20 amp output receptacles located on the output terminal panel, page 36, Figure 12.

The purpose of these receptacles is to provide power via commercial power to the jacket water heater and internal battery charger.

These receptacles will **ONLY** function when commercial power has been supplied to them (Figure 20). To apply commercial power to these receptacles, a power cord of adequate size will be required.

When using the generator in **hot** climates there is no reason to apply power to jacket water heater. However, if the generator will be used in **cold** climates it is always a good idea to apply power to the jacket water heater at all times. To apply power to the jacket water heater simply apply power to the jacket water heater receptacle via commercial power using an power cord of adequate size.

If the generator will be used daily, the battery should normally not require charging. If the generator will be idle (not used) for long periods of time, apply power to the battery charger receptacle via commercial power using an power cord of adequate size.

When connecting the generator to a isolation (transfer) switch, **ALWAYS** have power applied to the generator's internal battery charger. This will ensure that the engine will not fail due to a dead battery.

CAUTION:



ALWAYS have power applied to the generator's internal battery charger when connecting the generator to a isolation (transfer) switch. Remember before connecting this generator to any buildings electrical system, have a **licensed** electrician perform the installation of the transfer switch.

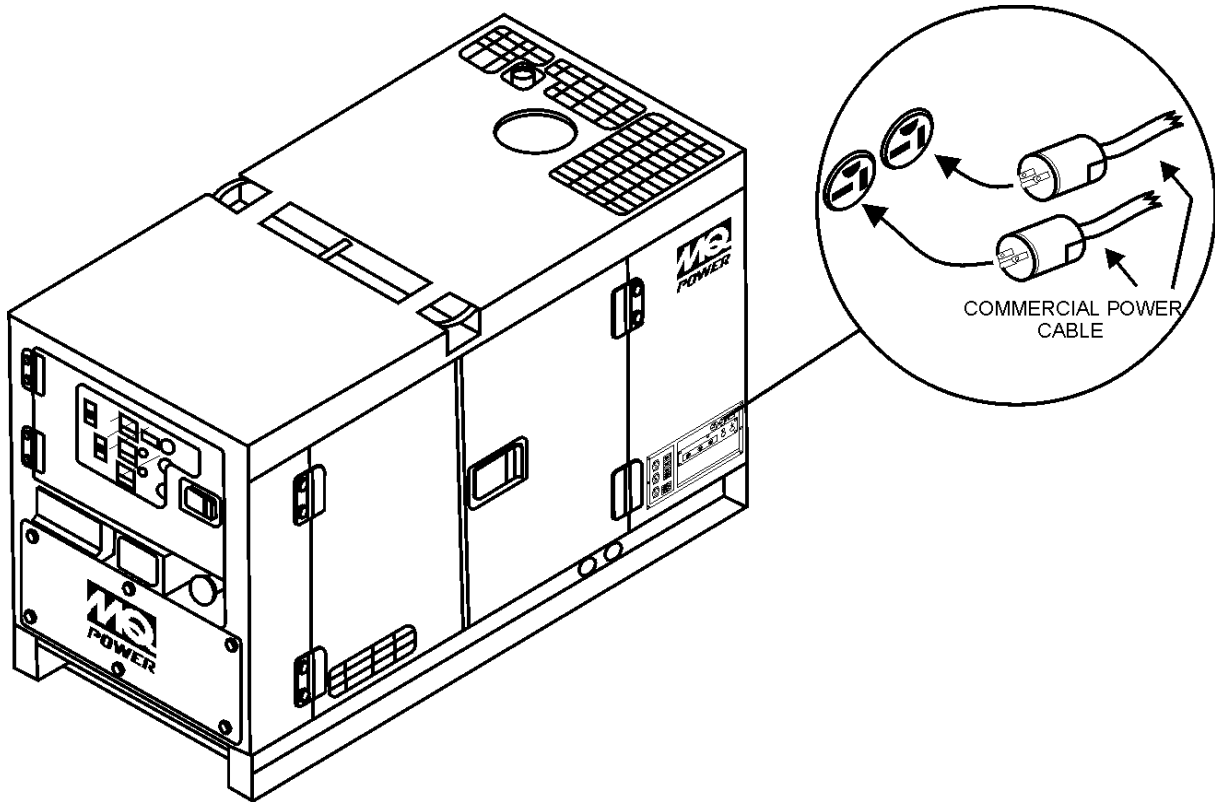

Figure 19. 120 VAC Accessory Receptacle/Cable

2. Once it is determined if commercial power is required, connect the load to the UNV terminals as shown in Figure 20. These terminals can be found on the output terminal panel, see page 36 Figure 12. To gain access to the output terminals lift the UNV cover. Make sure to tighten terminal nuts securely to prevent load wires from slipping out.
3. Connect the negative battery cable (BLACK) to the negative post on the battery (Figure 21).

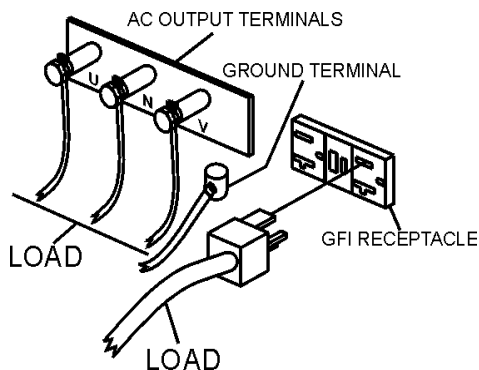

Figure 20. UNV Terminal Lugs (Load)

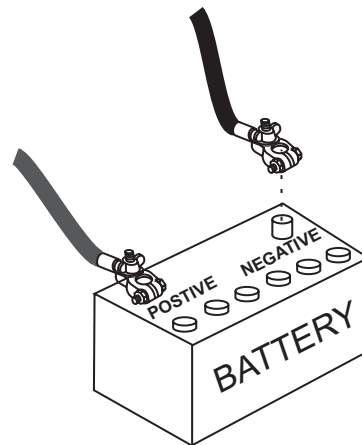

Figure 21. Battery Connections

DCA-220SSK — GENERATOR START-UP PROCEDURE (MANUAL)

4. Close all engine enclosure doors (Figure 22).

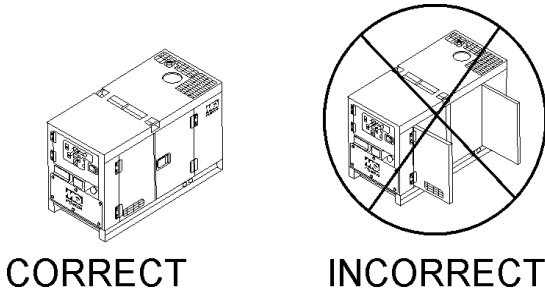

Figure 22. Engine Enclosure Doors

5. Set the battery ON/OFF switch (Figure 23) to the ON position.

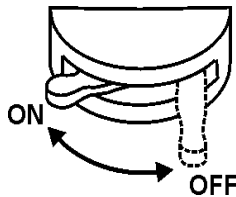

Figure 23. Battery ON/OFF Switch

6. When starting the generator in **COLD** weather conditions, press and hold the engine preheat button (Figure 24) until the pre-heat lamp (Figure 25) is lit (ON).



Figure 24. Engine Pre-Heat Button



Figure 25. Engine Pre-Heat Lamp

7. Place the Off/Manual/Auto switch (Figure 26) in the **MANUAL** position (down). Observe that the engine begins to crank.

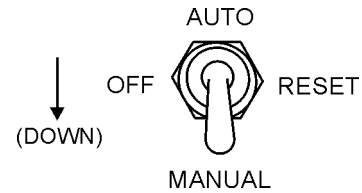

Figure 26. Off/Manual/Auto Switch (Manual)

8. After engine starts, verify that the "Engine Running" status LED (Figure 27) on the Microprocessor Engine Control Module (MPEC) display is "ON" (lit).



Figure 27. MPEC Engine Running Status LED

DCA-220SSK — GENERATOR START-UP PROCEDURE (MANUAL)

9. The generator's frequency meter (Figure 28) displays the 60 cycle output frequency in **HERTZ**.

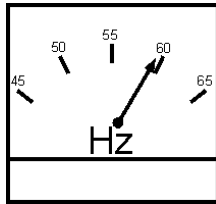

Figure 28. Frequency Meter (Hz)

10. The generator's voltage meter (Figure 29) displays the 120 VAC in **VOLTS**. If the voltage is not within the specified frequency tolerance, use the voltage adjustment control knob (Figure 30) to increase or decrease the desired voltage.

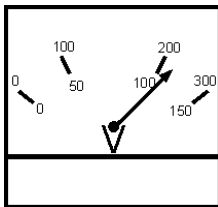

Figure 29. Voltage Meter (Volts)

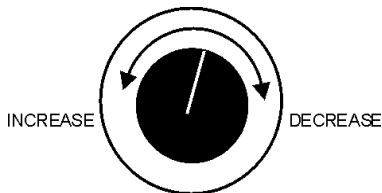

Figure 30. Voltage Adjust Control Knob

11. The ammeter (Figure 31) will indicate zero amps with no load applied. When a load is applied, this meter will indicate the amount of current that the load is drawing from the generator's alternator.

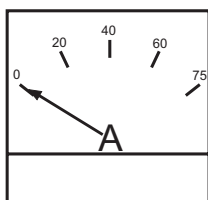

Figure 31. Ammeter (No Load)

12. The wattmeter (Figure 32) will indicate zero watts with no load applied. When a load is applied, this meter will indicate the output power of the generator with respect to the applied load.

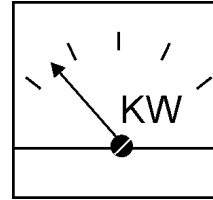

Figure 32. Kilowatt Meter

13. The engine oil pressure gauge (Figure 33) will indicate the oil pressure (kg/ cm²) of the engine. Under normal operating conditions the oil pressure should be approximately 25 psi.

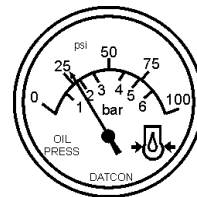

Figure 33. Oil Pressure Gauge

14. The coolant temperature gauge (Figure 34) will indicate the coolant temperature. Under normal operating conditions the coolant temperature should be between 165 and 215 degrees fahrenheit (Green Zone).

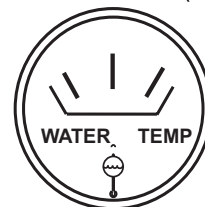

Figure 34. Coolant Temperature Gauge

15. Set the engine speed switch (Figure 35) to low to idle engine, set to high when a load is being applied.

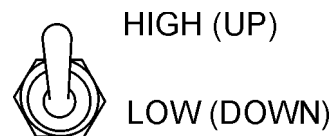

Figure 35. Engine Speed Switch

DCA-220SSK — GENERATOR START-UP PROCEDURE (MANUAL)

16. The tachometer (Figure 36) will indicate the speed of the engine when the generator is operating. Under normal operating conditions this speed should be approximately 1800 RPM's.

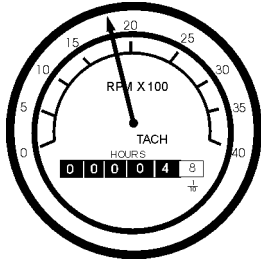

Figure 36. Engine Tachometer

17. If the engine speed is too high or low, use the high idle adjust trimmer (Figure 37) located in the control box to adjust the rated speed of the engine.

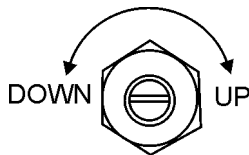

Figure 37. Engine Idle Adjust Trimmer

18. After the engine has been running for a few minutes, look at the status LED'S on the "MPEC" display (Figure 27) and check it for any abnormal conditions. If any abnormal conditions exist, shut down the engine and take corrective action to solve the problem.
19. If there are no abnormal problems shown on the "MPEC" LED display, turn the MAIN, GFCI and LOAD circuit breakers to their ON position (Figure 38).

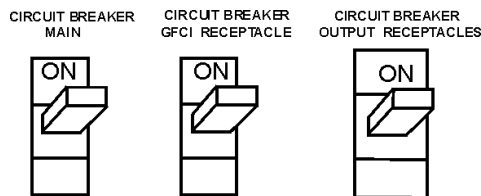

Figure 38. Main and GFCI Circuit Breakers

20. Observe the generator's ammeter (Figure 39) and verify that it reads the anticipated amount of current with respect to the load. Remember the ammeter will only display a current reading if the load is in use.

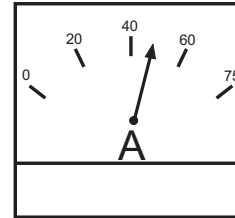

Figure 39. Ammeter (Load)

21. The generator will run until manually stopped or an abnormal condition occurs.

DCA-220SSK — GENERATOR START-UP PROCEDURE (AUTO)

CAUTION:



Before connecting this generator to any building's electrical system, a **licensed electrician** must install an isolation (transfer) switch. Serious ***injury*** or ***death*** may result without this transfer switch.

CAUTION:



When connecting the generator to a isolation (transfer) switch, **ALWAYS** have power applied to the generator's internal battery charger. This will ensure that the engine will not fail due to a dead battery.

Starting the generator in the "**AUTO**" mode is similar to starting the generator in the "**MANUAL**" mode, with a few exceptions.

CAUTION:



When running the generator in the **AUTO** mode, remember the generator can start up at any time without warning. **NEVER** attempt to perform any maintenance when the generator is in the auto mode.

When starting generator in Auto mode use the "Manual Start-up" procedure except where noted (see below).

1. Perform steps 1 through 6 (Before Starting, page 35-39) as outlined in the manual starting procedure.
2. Apply commercial power to the internal battery charger receptacle (to ensure good starting) via commercial power. An external power cord will be required.
3. Apply commercial power to the jacket water heater receptacle (not necessary for warm climates) via commercial power. An external power cord will be required.
4. Place the Off/Manual/Auto switch (Figure 40) in the **AUTO** position (up).

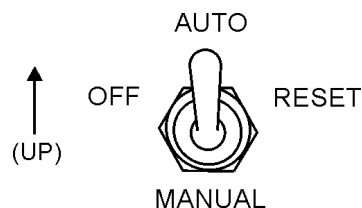

Figure 40. Off/Manual Auto Switch (AUTO)

5. Continue to follow the steps outline in the manual start-up procedure (start at step 9, page 38).

DCA-220SSK — GENERATOR SHUT-DOWN PROCEDURE

Engine Shutdown

To shut-down the generator use the following procedure:

1. Place both the **MAIN**, **GFCI** and **LOAD** circuit breakers to the "OFF position".
2. Set the engine speed switch (Figure 41) to the idle (low) position.

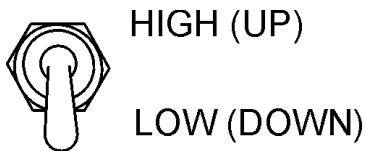

Figure 41. Engine Speed Switch

3. Let the engine cool by running it for 3-5 minutes with no load applied.
4. Place the Off/Manual/Auto Switch (Figure 42) in the "OFF/RESET" position

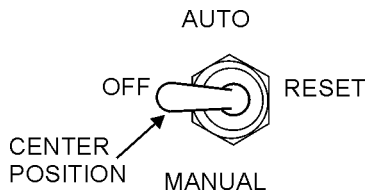

Figure 42. Off/Manual Auto Switch (OFF)

5. Verify that the "Engine Running" status LED (Figure 43) on the Microprocessor Engine Control Module (MPEC) display is "OFF" (not lit).

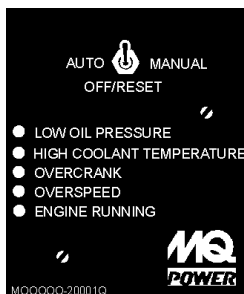

Figure 43. MPEC Engine Running Status LED (OFF)

6. Remove the load from the UNV terminal strip (Figure 20).

Emergency Stop

1. To stop the engine in the event of an emergency, **PUSH** the emergency stop button (Figure 44) inward. This button is located on the generator's engine operating panel, see page 26, Figure 5.



Figure 44. Emergency Stop Button

CAUTION:

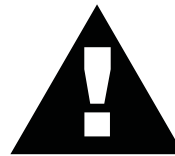

NEVER stop the engine suddenly except in an emergency. **DO NOT** use the emergency stop switch as a method of shutting down the engine. This switch is **ONLY** to be used in the event of an emergency.

General Inspection

Prior to each use, the generating set should be cleaned and inspected for deficiencies. Check for loose, missing or damaged nuts, bolts or other fasteners. Also check for fuel or oil leaks.

Engine Side, Fuel, Oil and Coolant (Refer to the Engine Instruction Manual).

Air Cleaner

Every 50 hours: Remove air cleaner element and clean heavy duty paper element with kerosene, or foam element with liquid detergent and hot water. Wrap foam element in a cloth and squeeze dry. For heavy duty paper element, wipe excess kerosene with towel

Fuel Addition

Add diesel fuel (the grade may vary according to season and locations). Always pour through the mesh filter.

Removing Water from the Tank

After prolonged use, water and other impurities accumulate in the bottom of the tank. Occasionally remove the drain cock and drain the contents. During cold weather, the greater the empty volume inside the tank, the easier it is for water to condense. This can be reduced by always keeping the tank as full as possible.

Air Removal

If air enters the fuel injection system of a diesel engine, starting becomes impossible. After running out of fuel, or after disassembling the fuel system, bleed the system according to the following procedure.

To restart after running out of fuel, turn the key switch to the "START" position for 15-30 seconds. Try again, if needed. This unit is equipped with an automatic air bleeding system.

Service Daily

If engine is operating in very dusty and dry grass conditions, a clogged air cleaner will result in high fuel consumption, loss of power and excessive carbon buildup in the combustion chamber.

Cleaning the Fuel Strainer

Clean the fuel strainer if it contains dust or water. Remove dust or water in the strainer cap and wash it in diesel. Securely fasten the fuel strainer cap so that fuel will not leak. Check the fuel strainer every 200 hours of operation or once a month.

Check Oil Level

Check the crankcase oil level prior to each use, or when the fuel tank is filled. Insufficient oil may cause severe damage to the engine. Make sure the generator is level. The oil level must be between the two notches on the dipstick as shown in Figure 15, page 41.

Generator Storage

For storage of the generator for over 30 days, the following is required:

- Drain the fuel tank completely.
- Completely drain the oil from the crankcase and refill with fresh oil.
- Clean all external parts of the generator with a cloth.
- Cover the generating set and store in a clean, dry place.

Water Separator Filter

Replace the water separator filter (Figure 45) every 500 hours if two filters are being used. If one filter is being used, replace every 250 hours.

The filters should also be replaced if the vacuum gauge indicates between 6 to 10 inches of mercury (in Hg).

6-10 in. Hg.
REPLACE WATER
SEPARATOR FILTER
IF GAUGE READS
IN THIS RANGE

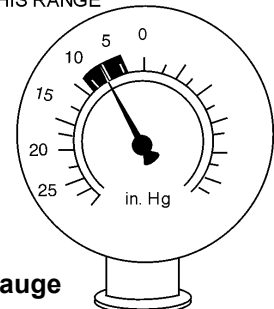

Figure 45. Water Separator Gauge

To replace the **water separator filter** element perform the following:

1. Remove the lid from the filter housing. Remove the element by holding the module handle and slowly pulling upward with a twisting motion.
2. Replace the lid gasket with the one supplied with the new filter element. Apply a coating of clean fuel or motor oil to seal prior to reassembly. Insert the new filter element with a slow downward twisting motion.
3. Fill the unit with clean fuel, then set the lid back on top of the filter housing, and tighten snugly using the T-bar handle.
4. Start the engine and check for any leaks. If any leaks occur with the engine running, turn the engine off and fix the leak.

INSPECTION / MAINTENANCE		10 Hrs DAILY	250 Hrs	500 Hrs	1000 Hrs
ENGINE	Check Engine Fluid Levels	X			
	Check Air Cleaner	X			
	Check Battery Acid Level	X			
	Check Fan Belt Condition	X			
	Check for Leaks	X			
	Check for Loosening of Parts	X			
	Check Water Separator	X			
	Check Blow-by Oil Mist Tank	X			
	Replace Engine Oil and Filter *1		X		
	Clean Air Filter		X		
	Drain Bottom of Fuel Tank		X		
	Clean Unit, Inside and Outside		X		
	Change Fuel Filter *2			X	
	Replace Water Separator Element *3		(X)	X	
	Clean RAdiator and Check Coolant Protection Level			X	
	Replace Air Filter Element				X
	Change Corrosion Resistor				X
Check all Hoses and Clamps				X	
Clean Inside of Fuel Tank				X	
GENERATOR	Measure Insulation Resistance Over 3M ohms		X		

*1 Replace engine oil and filter at 100 hours, first time only.

*2 Replace fuel filter at 250 Hours, first time only.

*3 Refer to the item "Water Separator Filter".

DCA-220SSK — GENERATOR WIRING DIAGRAM

DCA220SSK GENERATOR
WIRE DIAGRAM.
GEER 2000

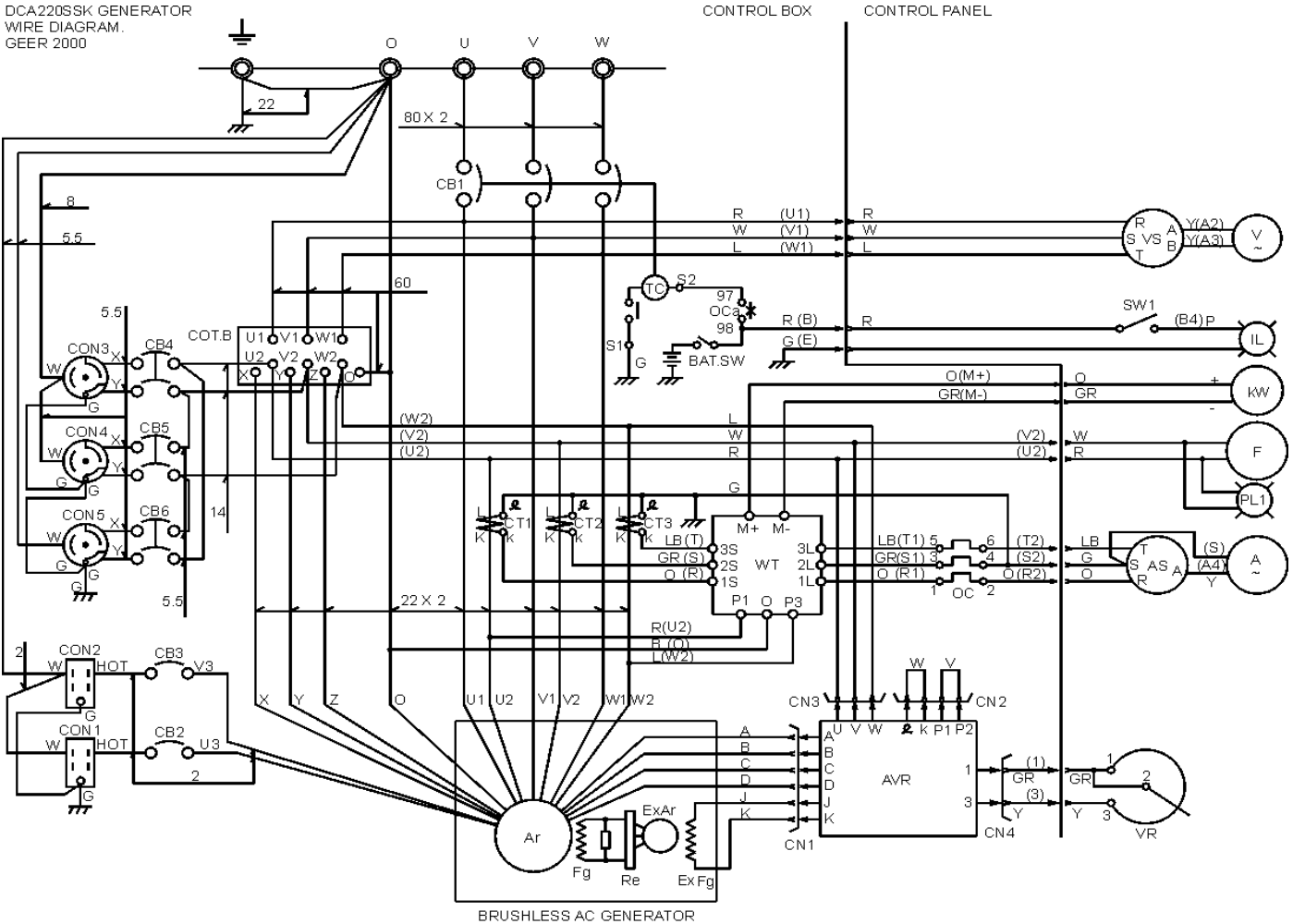

AVR CONNECTOR

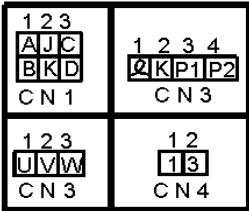

(VIEW FROM INSERTING WIRE SIDE)

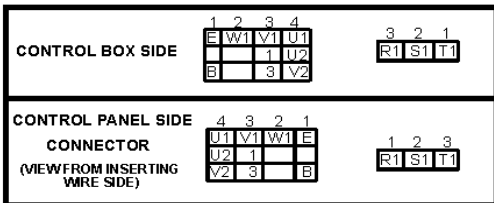

SETTING FOR OUTPUT VOLTAGE

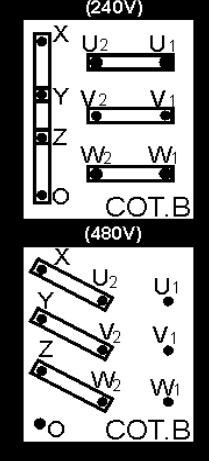

80:	80mm ²
60:	60mm ²
22:	22mm ²
14:	14mm ²
8:	8mm ²
5.5:	5.5mm ²
2:	2mm ²
NO MARK:	1.25mm ²

CODE/ WIRE COLOR	
B	BLACK
L	BLUE
BR	BROWN
G	GREEN
GR	GRAY
V	VIOLET
P	PINK
R	RED
W	WHITE
Y	YELLOW
LB	LIGHT BLUE
LG	LIGHT GREEN
O	ORANGE

MARK	NAME
Ar	MAIN GENERATOR ARMATURE WINDING
Fg	MAIN GENERATOR FIELD WINDING
ExAr	EXCITER ARMATURE WINDING
ExFg	EXCITER FIELD WINDING
AVR	AUTOMATIC VOLTAGE REGULATOR
VR	VOLTAGE REGULATING RHEOSTAT
Re	RECTIFIER
CT1~3	CURRENT TRANSFORMER (400/5A)
C B 1	CIRCUIT BREAKER (600A)
OC	OVER CURRENT RELAY
COT. B	VOLTAGE CHANGE-OVER BOARD
AS	AMMETER CHANGE-OVER SWITCH
A	AC AMMETER (0~400, 800A)
VS	VOLTMETER CHANGE-OVER SWITCH
V	AC VOLTMETER (0~600V)
F	FREQUENCY METER (45~65HZ)
PI1	PILOT LAMP
CB2, 3	AUX. CIRCUIT BREAKER (20A)
CB4~6	AUX. CIRCUIT BREAKER (50A)
CON1, 2	AUX POWER RECEPTACLE (20A)
CON3~5	AUX POWER RECEPTACLE (50A)
IL	PANEL LIGHT
SW1	PANEL LIGHT SWITCH
kW	WATTMETER -20 ~200 KW
WT	WATT-METER TRANSDUCER

DCA-220SSK — ENGINE WIRING DIAGRAM

DCA220SSK ENGINE WIRE DIAGRAM
GEER 2000

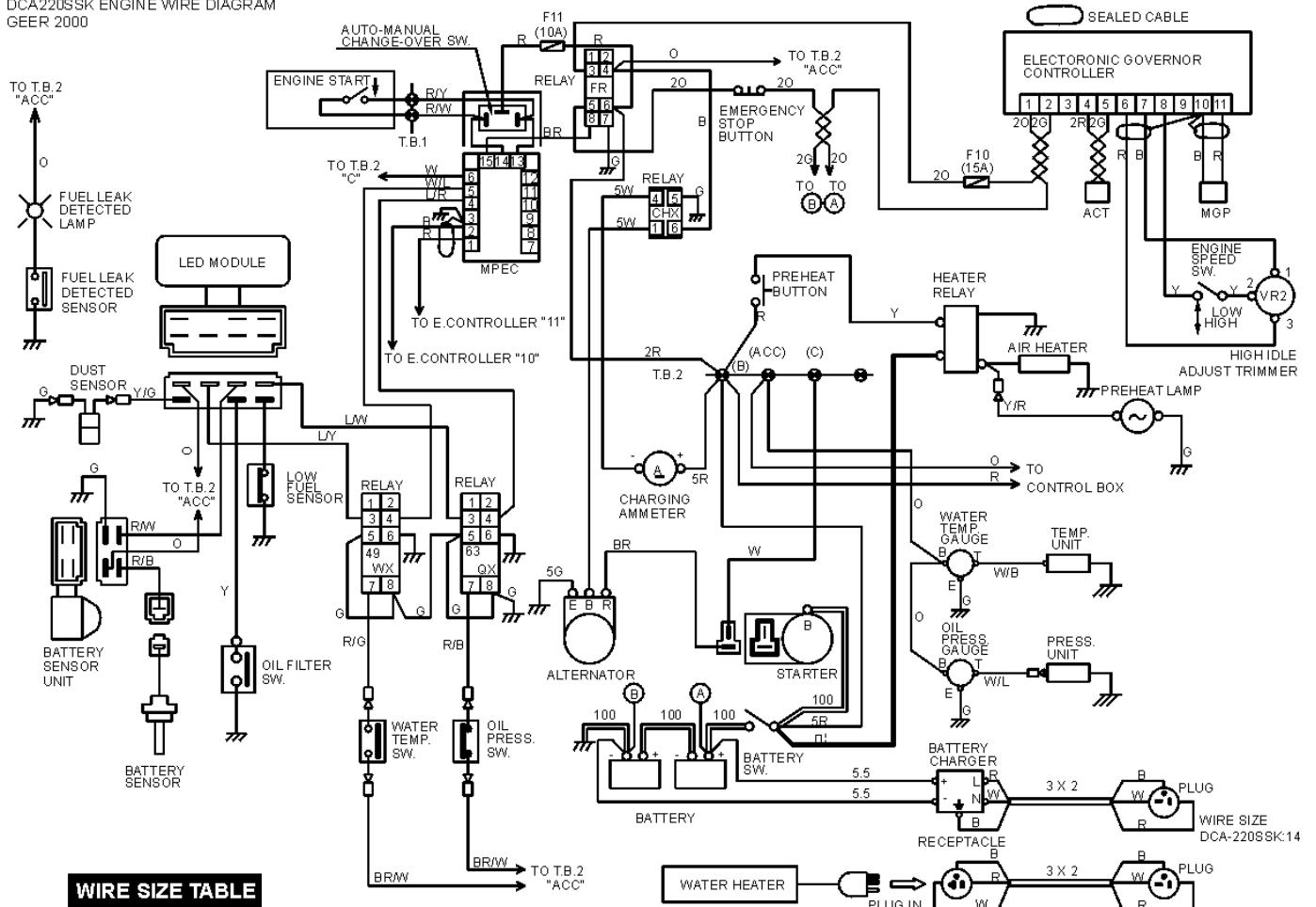

100:	100mm ²
38:	38mm ²
22:	22mm ²
14:	14mm ²
5:	5mm ²
2:	2mm ²
NO MARK:	2 mm ²

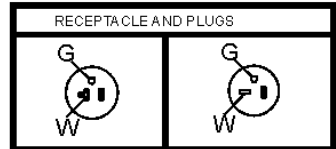

CODE/ WIRE COLOR			
B	BLACK	R	RED
L	BLUE	W	WHITE
BR	BROWN	Y	YELLOW
G	GREEN	LB	LIGHT BLUE
GR	GRAY	LG	LIGHT GREEN
V	VIOLET	O	ORANGE
P	PINK		

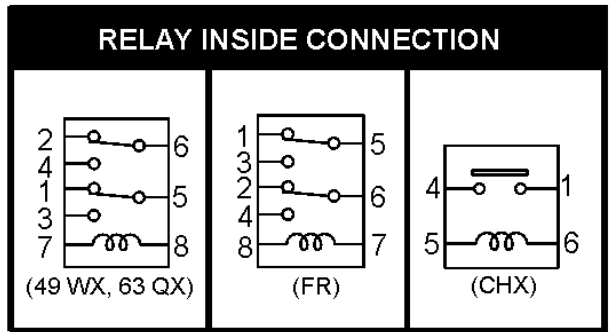

DCA-220SSK — TROUBLESHOOTING (ENGINE)

Practically all breakdowns can be prevented by proper handling and maintenance inspections, but in the event of a breakdown, use the tables shown for

diagnosis based on the Engine Troubleshooting (Table 13). If the problem cannot be remedied, consult our company's business office or service plant.

TABLE 13. ENGINE TROUBLESHOOTING

SYMPTOM	POSSIBLE PROBLEM	SOLUTION
Engine does not start.	No fuel?	Replenish fuel.
	Air in the fuel system?	Bleed system.
	Water in the fuel system?	Remove water from fuel tank.
	Fuel pipe clogged?	Clean fuel pipe.
	Fuel filter clogged?	Clean or change fuel filter.
	Excessively high viscosity of fuel or engine oil at low temperature?	Use the specified fuel or engine oil.
	Fuel with low cetane number?	Use the specified fuel.
	Fuel leak due to loose injection pipe retaining nut?	Tighten nut.
	Incorrect injection timing?	Adjust.
	Fuel cam shaft worn?	Replace.
	Injection nozzle clogged?	Clean injection nozzle.
	Injection pump malfunctioning?	Repair or replace.
	Seizure of crankshaft, camshaft, piston, cylinder liner or bearing?	Repair or replace.
	Compression leak from cylinder?	Replace head gasket, tighten cylinder head bolt, glow plug and nozzle holder.
	Improper valve timing?	Correct or replace timing gear.
	Piston ring and liner worn?	Replace.
Excessive valve clearance?	Adjust.	
Starter does not run.	Battery discharged?	Charge battery.
	Starter malfunctioning?	Repair or replace.
	Key switch malfunctioning?	Repair or replace.
	Wiring disconnected?	Connect wiring.

DCA-220SSK — TROUBLESHOOTING (ENGINE)

TABLE 13. ENGINE TROUBLESHOOTING (CONTINUED)

SYMPTOM	POSSIBLE PROBLEM	SOLUTION
Engine revolution is not smooth.	Fuel filter clogged or dirty?	Clean or change.
	Air cleaner clogged?	Clean or change.
	Fuel leak due to loose injection pipe retaining nut?	Tighten nut.
	Injection pump malfunctioning?	Repair or replace.
	Incorrect nozzle opening pressure?	Adjust.
	Injection nozzle stuck or clogged?	Repair or replace.
	Fuel over flow pipe clogged?	Clean.
	Governor malfunctioning?	Repair.
Either white or blue exhaust gas is observed.	Excessive engine oil?	Reduce to the specified level.
	Piston ring and liner worn or stuck?	Repair or replace.
	Incorrect injection timing?	Adjust.
	Deficient compression?	Adjust top clearance.
Either black or dark gray exhaust gas is observed.	Overload?	Lessen the load.
	Low grade fuel used?	Use the specified fuel.
	Fuel filter clogged?	Clean or change.
	Air cleaner clogged?	Clean or change.
	Deficient nozzle injection?	Repair or replace the nozzle.
Deficient output.	Incorrect injection timing?	Adjust.
	Engine's moving parts seem to be seizing?	Repair or replace.
	Uneven fuel injection?	Repair or replace the injection pump.
	Deficient nozzle injection?	Repair or replace the nozzle.
	Compression leak?	Replace head gasket, tighten cylinder head bolt, glow plug and nozzle holder.

DCA-220SSK — TROUBLESHOOTING (GENERATOR/ENGINE)

Practically all breakdowns can be prevented by proper handling and maintenance inspections, but in the event of a breakdown, use the tables shown for diagnosis based on the Engine and Radiator Troubleshooting (Table 14) and MPEC Troubleshooting on next page (Table 15). If the problem cannot be remedied, consult our company's business office or service plant.

TABLE 14. ENGINE & GENERATOR TROUBLESHOOTING

SYMPTOM	POSSIBLE PROBLEM	SOLUTION
Engine fails to start and starter does not rotate.	Dead battery?	Replace battery.
	Defective starter switch?	Replace switch.
	Fuse F5 burned out?	Replace fuse.
Engine fails to start and starter rotates.	Broken pre-heat circuit?	Check pre-heat circuit.
	No fuel?	Add fuel.
	Defective wiring?	Check wiring.
Engine starts and remains at low speed.	Clogged fuel strainer?	Clean or replace.
	Clogged air cleaner?	Clean or replace.
	Disconnected wiring?	Check and repair wiring.
Engine speed rises and no voltage is present in AC power source.	No voltage present in AC power source?	Replace rectifier (RE1).
	Defective rotor?	Replace rotor.
	Defective voltmeter?	Replace voltmeter.
	Disconnected wiring?	Check and repair wiring.
	Layer short-circuit in armature winding?	Replace armature.
Engine speed rises and AC power voltage is too low or cannot be used.	Defective circuit breaker (protector)?	Replace circuit breaker (protector).
	Layer short-circuit, broken wires in armature winding?	Repair or replace armature.
Engine speed rises and battery discharges too soon.	Defective engine regulator?	Replace regulator.
	Defective wiring?	Repair or replace wiring.
Engine speed rises and engine seems overloaded.	Defective alternator?	Repair or replace alternator.
	Damaged alternator bearing?	Replace alternator bearings.

TABLE 15. MPEC TROUBLESHOOTING

Sympton	Possible Cause	Solution
Low oil pressure light is on.	Low oil level?	Fill oil level.
	Oil pressure sending unit failure?	Replace oil pressure sending unit.
	Time delay malfunction in MPEC?	Refer to dealer.
	Wire shorted?	Inspect/repair wire.
Low coolant level light is on.	Low coolant level?	Fill coolant level.
	Sending unit failure?	Replace sending unit.
	Low battery voltage?	Replace/charge battery.
High coolant temperature light is on.	Fan belt tension incorrect?	Tighten/replace fan belt.
	Air flow is not circulation through radiator?	Clean/repair radiator grill.
	Doors open?	Close doors.
	Exhaust leaking?	Replace/repair gaskets or faulty part.
	Generator being overloaded?	Check/reduce load.
	Thermostat failure?	Replace thermostat.
	Air intake blocked?	Clear all air intakes.
Overcrank light is on.	Temperature switch failure?	Replace temperature switch.
	No or low Fuel?	Fill fuel level.
Overspeed light is on.	MPEC needs to be calibrated?	Refer to dealer.
	RPM engine speed too high?	Adjust RPM.
	Governor actuator needs to be adjusted?	Adjust governor actuator.
	Governor controller needs to be adjusted?	Adjust governor controller.
Loss of MPU light(s) or on.	MPEC needs to be calibrated?	Refer to dealer.
	Magnetic pick up out of adjustment?	Adjust magnetic pick up.
	Magnetic pick up dirty?	Clean magnetic pick up.

EXPLANATION OF CODE IN REMARKS COLUMN

How to read the marks and remarks used in this parts book.

Items Found In the “Remarks” Column

Serial Numbers-Where indicated, this indicates a serial number range (inclusive) where a particular part is used.

Model Number-Where indicated, this shows that the corresponding part is utilized only with this specific model number or model number variant.

Items Found In the “Items Number” Column

All parts with same symbol in the number column, *, #, +, %, or ■, belong to the same assembly or kit.

Note: If more than one of the same reference number is listed, the last one listed indicates newest (or latest) part available.

DCA-220SSK — SUGGESTED SPARE PARTS

DCA-220SSK W/KOMATSU S6D125E-2 DIESEL ENGINE

1 to 5 Units

Qty.	P/N	Description
5	6125817032	AIR FILTER
10	6003118293	FUEL FILTER
10	6002111231	OIL FILTER
5	6004111020	CARTRIDGE, CORROSION RESISTOR
1	0601805950	MAIN CIRCUIT BREAKER
1	0602115008	PILOT LAMP, ENGINE TROUBLE
2	0601810204	BULB
2	0412122262	ENGINE FAN BELT
2	6008711170	OIL SWITCH
1	6151619320	RADIATOR HOSE (UPPER)
1	6151619330	RADIATOR HOSE (LOWER)
1	0845500104	FUEL CAP
1	0601820625	AUTOMATIC VOLTAGE REGULATOR
1	0601807030	MAIN CIRCUIT BREAKER
1	0601840073	VOLTAGE REGULATOR (RHEOSTAT)
1	0601840121	KNOB, VOLTAGE REGULATOR
1	0601810072	PILOT LAMP
2	0601810261	BULB, PILOT LAMP
1	TR60110235100	CAP, RADIATOR
1	0602122200	UNIT, OIL PRESSURE
1	0602123204	UNIT, WATER TEMPERATURE
1	0602121052	CHARGING AMMETER
5	R30P	ELEMENT, WATER SEPARATOR S/N3696501 TO S/N3698949
1	LGX500	FUEL CONDITIONER S/N3698950~
10	R2010PMOR	ELEMENT, WATER SEPARATOR S/N3698950~

DCA-220SSK — GENERATOR ASSY.

GENERATOR ASSY.

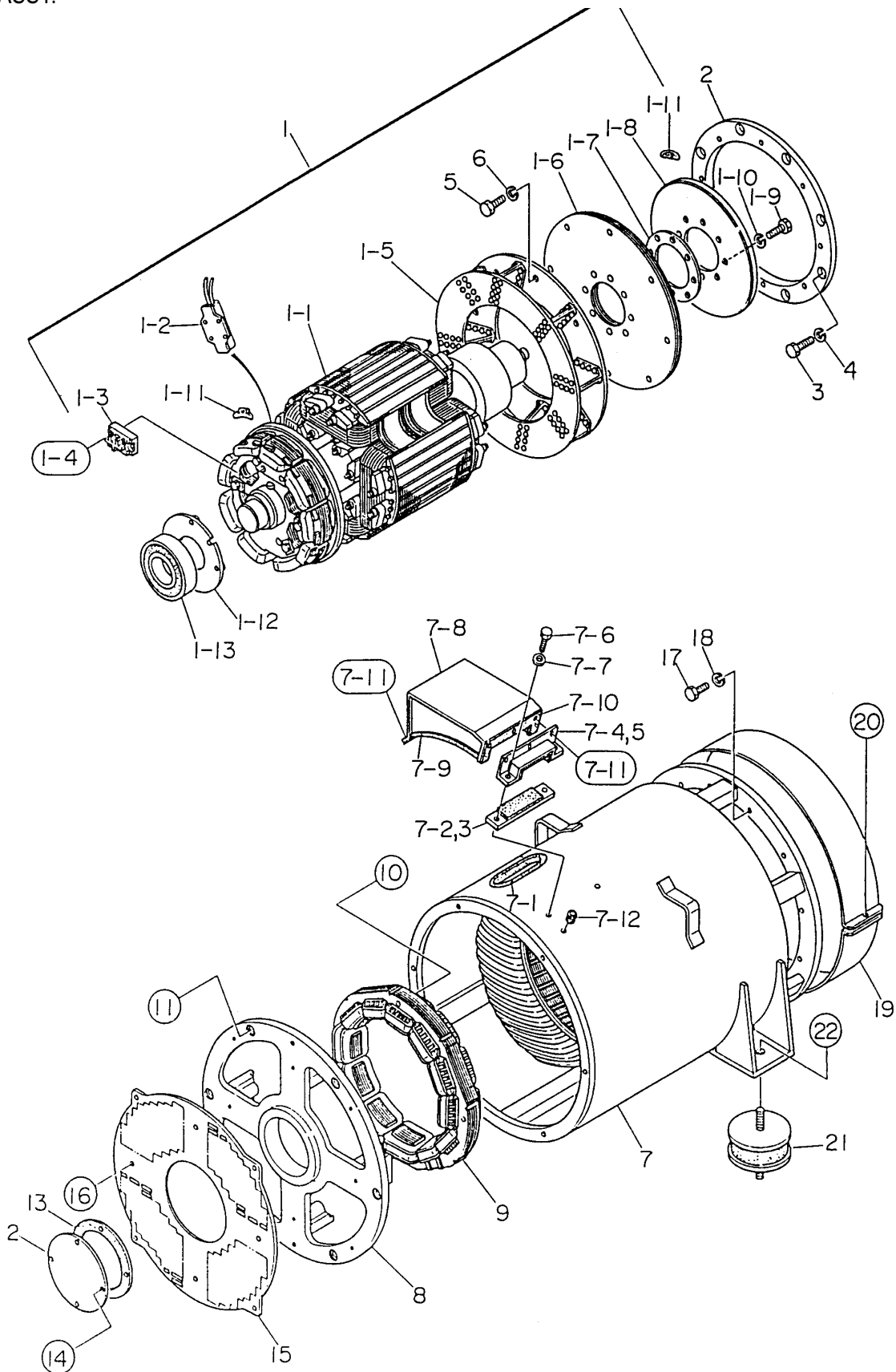

DCA-220SSK — GENERATOR ASSY.

GENERATOR ASSY.

<u>NO</u>	<u>PART NO</u>	<u>PART NAME</u>	<u>QTY.</u>	<u>REMARKS</u>
1	C1110100202	ROTOR ASSY.	1	INCLUDES ITEMS W/*
1-1*		FIELD ASSY.	1	
1-2*	0601842334	RESISTOR	1	SMRK 80W 100K OHM
1-3*	0601823282	RECTIFIER	1	RM507C24
1-4*	0018205020	HEX. SOCKET HEAD CAP SCREW	2	
	0040005000	LOCK WASHER	2	
	0041205000	PLAIN WASHER	2	
1-5*	8171070002	FAN	1	
1-6*	8171611003	COUPLING DISK	9	
1-7*	C1164200004	WASHER, COUPLING HUB	1	
1-8*	8171015003	BALANCING PLATE	1	
1-9*	0012116045	HEX. HEAD BOLT	8	
1-10*	0042616000	LOCK WASHER	10	
1-11*	0601000209	BALANCING WEIGHT KIT	1	
1-12*	C1112500004	BEARING FLANGE	1	
1-13*	0071906314	BEARING	1	6314DDUC3
2	8171614003	COUPLING RING	1	
3	0012112035	HEX. HEAD BOLT	8	
4	0042512000	LOCK WASHER	8	
5	0012112040	HEX. HEAD BOLT	8	
6	0042512000	LOCK WASHER	8	
7	C1130100103	STRATOR ASSY.	1	INCLUDES ITEMS W/%
7-1%	0226100420	RUBBER SEAL	1	
7-2%	8171323004	CLAMPER	1	
7-3%	0223300120	RUBBER SEAL	1	
7-4%	8171323103	CLAMPER	1	
7-5%	0221200300	RUBBER SEAL	1	
7-6%	0010110035	HEX. HEAD BOLT	2	
7-7%	0041210000	PLAIN WASHER	2	
7-8%	C1132200003	COVER	1	
7-9%	0226000510	RUBBER SEAL	2	
7-10%	0225000470	RUBBER SEAL	1	
7-11%	0017106016	HEX. HEAD BOLT	6	
7-12%	0601850144	GROMMET	1	
8	C1154000002	END BRACKET	1	
9	C1138000003	FIELD ASSY. EXCITER	1	
10	0012110065	HEX. HEAD BOLT	4	
	0042610000	LOCK WASHER	4	
	0041210000	PLAIN WASHER	4	
11	0017112045	HEX. HEAD BOLT	6	
12	C1154400004	COVER, BEARING	1	
13	C1154300004	GASKET, BEARING	1	
14	0010106060	HEX. HEAD BOLT	4	
	0040006000	LOCK WASHER	4	
	0041206000	PLAIN WASHER	4	
15	C1154400103	SUCTION COVER	1	

DCA-220SSK — GENERATOR ASSY.

GENERATOR ASSY.

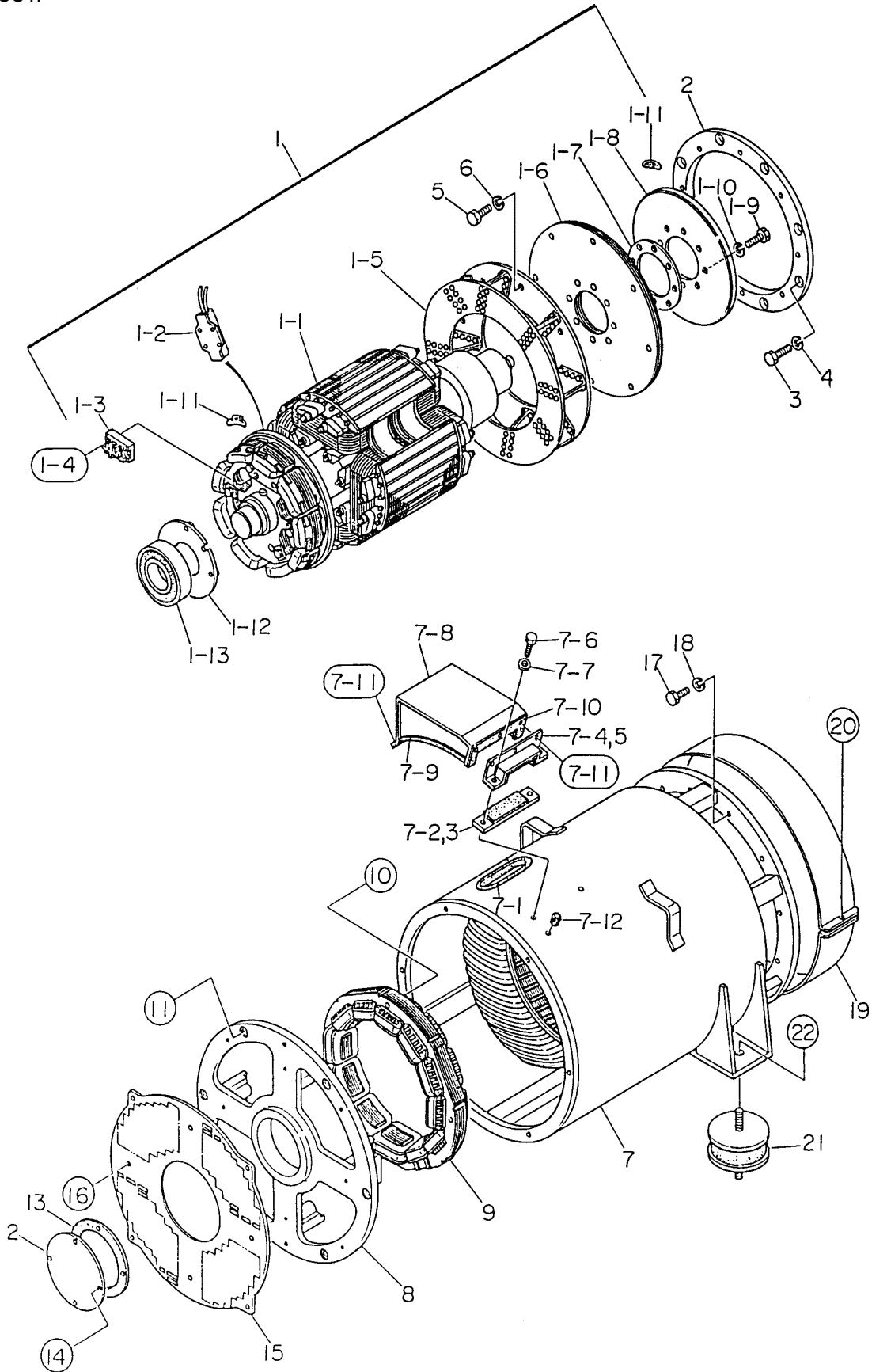

GENERATOR ASSY.

<u>NO</u>	<u>PART NO</u>	<u>PART NAME</u>	<u>QTY.</u>	<u>REMARKS</u>
16	0017106016	HEX. HEAD BOLT	8	
17	0012112035	HEX. HEAD BOLT	12	
18	0042512000	LOCK WASHER	12	
19	C1132300114	COVER, FAN	1	
20	0010106030	HEX. HEAD BOLT	1	
	0041206000	PLAIN WASHER	1	
	0600815000	NUT	1.....	USN6001
21	0605000012	RUBBER SUSPENSION	2.....	EA1013
22	003002000	HEX. NUT	4	
	004002000	LOCK WASHER	4	

DCA-220SSK — CONTROL PANEL ASSY.

CONTROL PANEL ASSY.

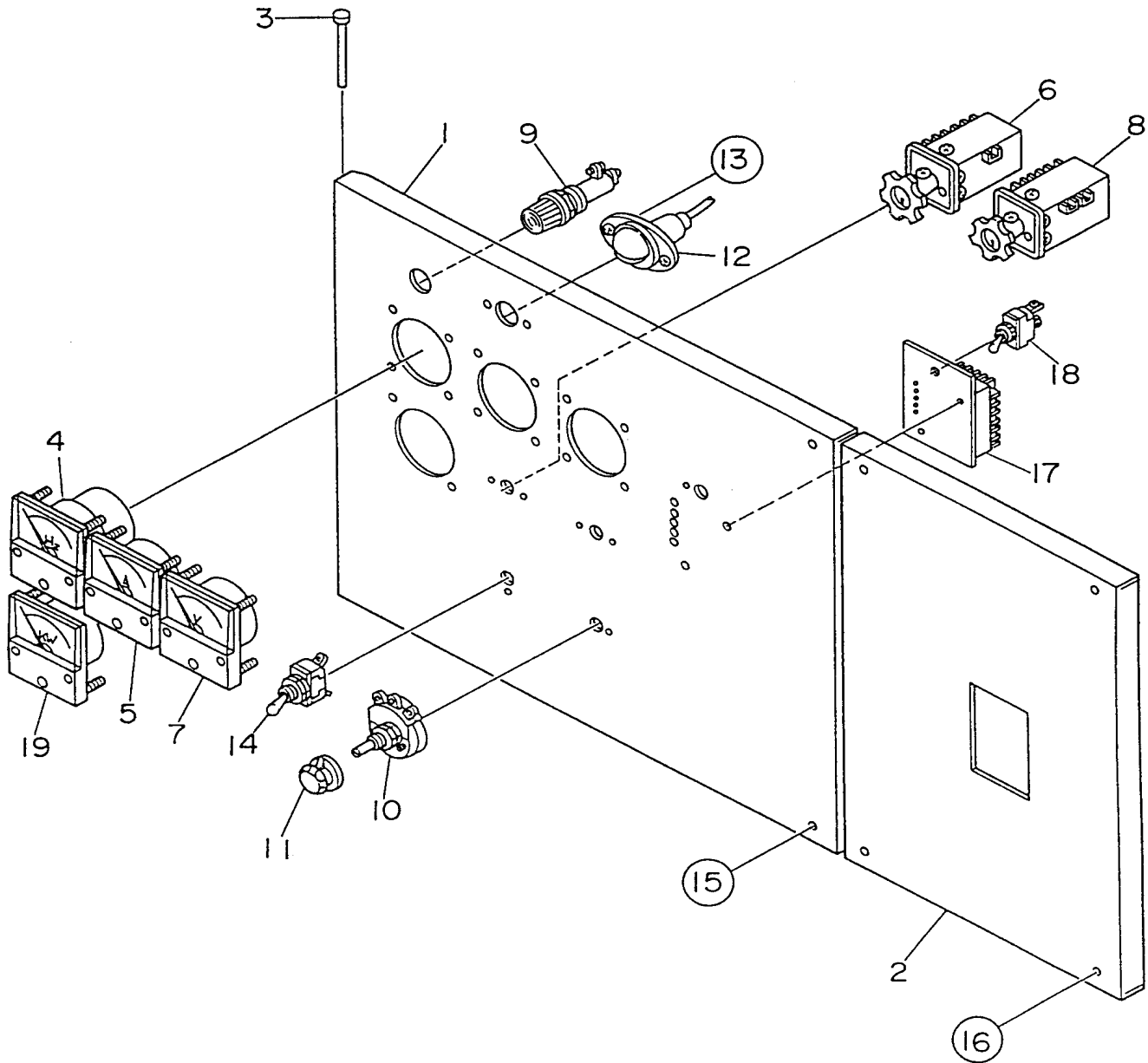

DCA-220SSK — CONTROL PANEL ASSY.

CONTROL PANEL ASSY.

<u>NO.</u>	<u>PART NO.</u>	<u>PART NAME</u>	<u>QTY.</u>	<u>REMARKS</u>
1	C1225000003	CONTROL PANEL	1	S/N3698950~
1	C1224000503	CONTROL PANEL	1	S/N3696501 TO S/N3698949
2	C1224000603	CONTROL PANEL	1	
3	0605011211	PIN	2	
4	0601807622	FREQUENCY METER	1	RSC80F 45 ~65HZ 200V
5	0601806980	AC AMMETER	1	RSS80 0 ~400A 0 ~800A
6	0601801040	CHANGE-OVER SWITCH ,AMMETER	1	SL2 AS
7	0601806887	AC VOLTMETER	1	RSR80 0 ~600V
8	0601801041	CHANGE OVER SWITCH, VOLTMETER	1	SL 2 VS
9	0601810072	PILOT LAMP	1	LP132DC 220V
	0601810261	BULB	1	CT13W
10	0601840073	RHEOSTAT (VOLTAGE REGULATOR)	1	RA20A2SE102BJ 2W 1K 0HM
11	0601840121	KNOB	1	
12	0601810161	PANEL LIGHT	1	V325070
	0601810214	BULB	1	
13	0207004000	HEX. NUT	2	
14	0601830710	SWITCH, PANEL LIGHT	1	S301T
15	C9221100004	HEX. HEAD BOLT	2	
	0040008000	LOCK WASHER	2	
	0041208000	PLAIN WASHER	2	
	0080200007	SNAP RING	2	
16	0017108040	HEX. HEAD BOLT	4	
17	ECU9988N	ENGINE CONTROLLER	1	S/N3698950~ REPLACES 0602202545
17	ECU88N	ENGINE CONTROLLER	1	S/N 696501 TO S/N3698949 REPLACES 0601827395
17-1	0601831340	SWITCH	1	S/N3696501 TO S/N3698949
18	0601830765	SWITCH	1	S/N3698950~
19	0601808716	AC WATTMETER	1	S/N3698950~ PXK 80A 20 ~ 200KW

DCA-220SSK — CONTROL BOX ASSY.

CONTROL BOX ASSY.

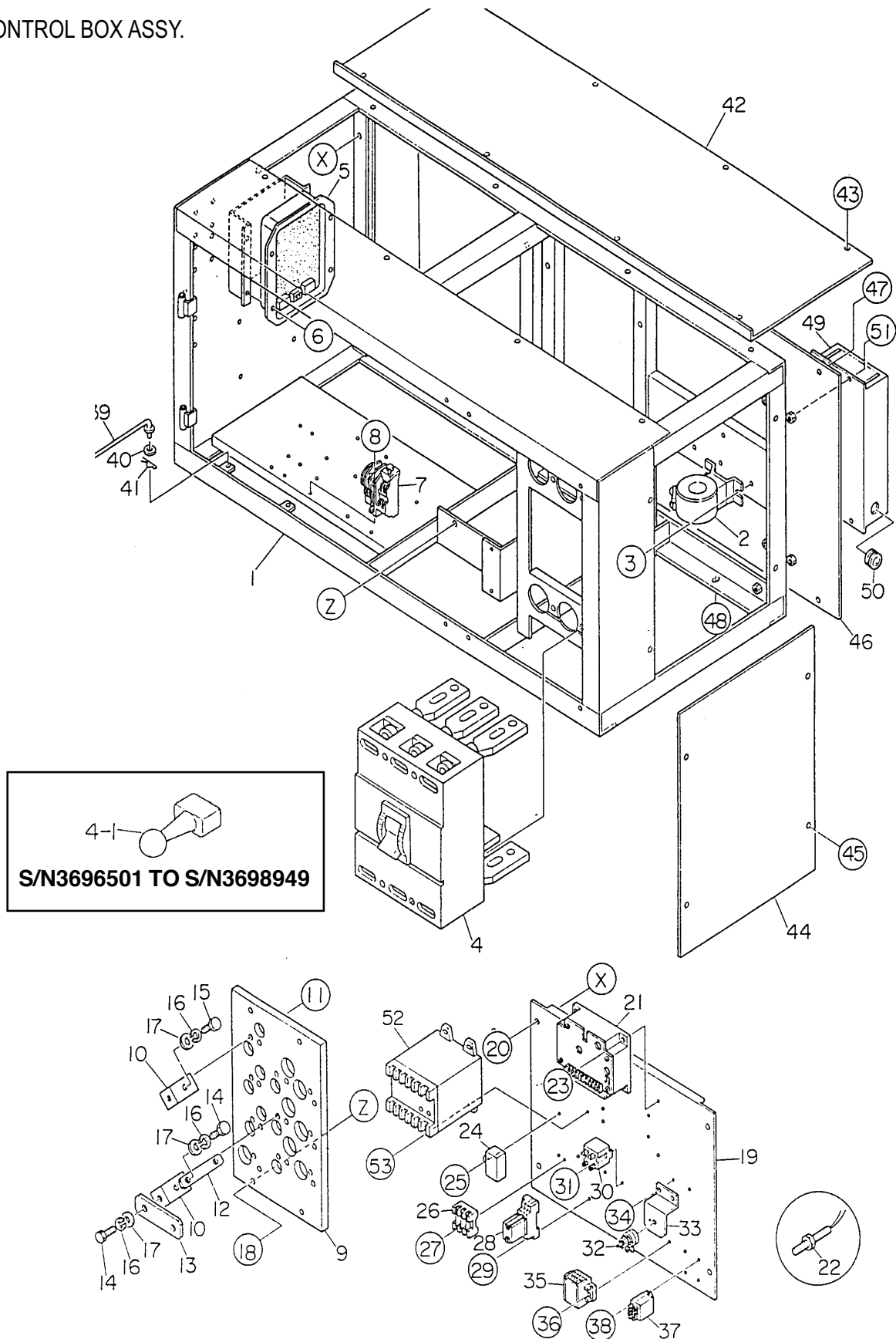

DCA-220SSK — CONTROL BOX ASSY.

CONTROL BOX ASSY.

<u>NO.</u>	<u>PART NO.</u>	<u>PART NAME</u>	<u>QTY.</u>	<u>REMARKS</u>
1	C1214000422	CONTROL BOX	1	
2	0601806133	CURRENT TRANSFORMER	3	CT5MRN 400/5A
3	0027106016	MACHINE SCREW	6	
4	0601807364	CIRCUIT BREAKER	1	XE600NS 600A
4-1	0601802525	HANDLE, CIRCUIT BREAKER	1	S/N3696501 TO S/N3698949
5	0601820625	AUTOMATIC VOLTAGE REGULATOR	1	NTA5A2T
6	0027105016	MACHINE SCREW	4	
7	0601820892	OVER CURRENT RELAY	1	THN20HZ
8	0027104016	MACHINE SCREW	2	
9	C1274000103	CHANGE- OVER BOARD, VOLTAGE	1	
10	8181852104	CHANGE TERMINAL	10	
11	011606025	HEX. HEAD BOLT	20	REPLACES 0017106025
12	C0277200004	TERMINAL PLATE	3	
13	8181853104	CHANGE PLATE	6	
14	8131852504	HEX. HEAD BOLT	13	
15	012210020	HEX. HEAD BOLT	13	REPLACES 0801831804
16	0040010000	LOCK WASHER	26	
17	0041410000	PLAIN WASHER	26	
18	011208030	HEX. HEAD BOLT	4	S/N3698950~ REPLACES 0017108030
18	0017110030	HEX. HEAD BOLT	4	S/N3696501 TO S/N3698949
19	C1262500014	SET PANEL, ELECTRIC PARTS	1	S/N3698950~
19	C1262500004	SET PANEL, ELECTRIC PARTS	1	S/N3696501 TO S/N3698949
20	011008020	HEX. HEAD BOLT	4	REPLACES 0017108020
21	DYN110654000024	CONTROLLER	1	REPLACES 0602202598
22	DYNT11100	SPEED SENSOR	1	REPLACES 0602120497
23	0027104020	MACHINE SCREW	4	
24	0602201911	UNIT, BATTERY SENSOR	1	C7038A00-00
25	0027106016	MACHINE SCREW	1	
26	0601806671	FUSE (LEFT)	1	F106515A
	0601802149	FUSE (RIGHT)	1	F106510A
	0601802218	HOLDER, FUSE	1	
27	0027104020	MACHINE SCREW	2	
28	LY2US23VDC	RELAY	1	S/N 3698950~ REPLACES 0601827655
28	LY2DC24V	RELAY	1	S/N3696501 TO S/N3698949; REPLACES 0601823732
	PTF08A	SOCKET	1	REPLACES 0601823109
	PYCA1	HOLDER	1	REPLACES 0601823109

DCA-220SSK — CONTROL BOX ASSY.

CONTROL BOX ASSY.

<u>NO.</u>	<u>PART NO.</u>	<u>PART NAME</u>	<u>QTY.</u>	<u>REMARKS</u>
29	0027104020	MACHINE SCREW	2	
30	0601823706	RELAY	1	HE1A DC
31	0027104014	MACHINE SCREW	2	
32	0601840009	RHEOSTAT	1	RA20A2SE502BJ 2W 5K OHM
33	C3262600004	BRACKET	1	
34	0017106016	HEX. HEAD BOLT	2	
35	0601815402	TERMINAL BOARD	1	
36	0027104020	MACHINE SCREW	2	
37	0601824542	RELAY	2	HH62S DC24V
38	0027103010	MACHINE SCREW	4	
39	3871824004	STOPPER, CONTROL PANEL	1	
40	0041206000	PLAIN WASHER	1	
41	505015300	SNAP PIN	1	REPLACES 0605010502
42	C1214500004	COVER, CONTROL BOX	1	
43	011008020	HEX. HEAD BOLT	8	REPLACES 0017108020
44	C1214300004	SIDE PANEL, CONTROL BOX	1	
45	011008020	HEX. HEAD BOLT	4	REPLACES 0017108020
46	C1215400004	PANEL, CONTROL BOX	1	
47	0017110025	HEX. HEAD BOLT	8	
48	0017110025	HEX. HEAD BOLT	4	
49	LC245002	BATTERY CHARGER	1	REPLACES 0601823090
50	0601850263	GROMMET	2	
51	0017105016	HEX. HEAD BOLT	4	
52	0601808504	TRANSDUCER	1	S/N3698950~
53	0027105020	MACHINE SCREW	4	S/N3698950~

DCA-220SSK — ENGINE & RADIATOR ASSY.

ENGINE & RADIATOR ASSY.

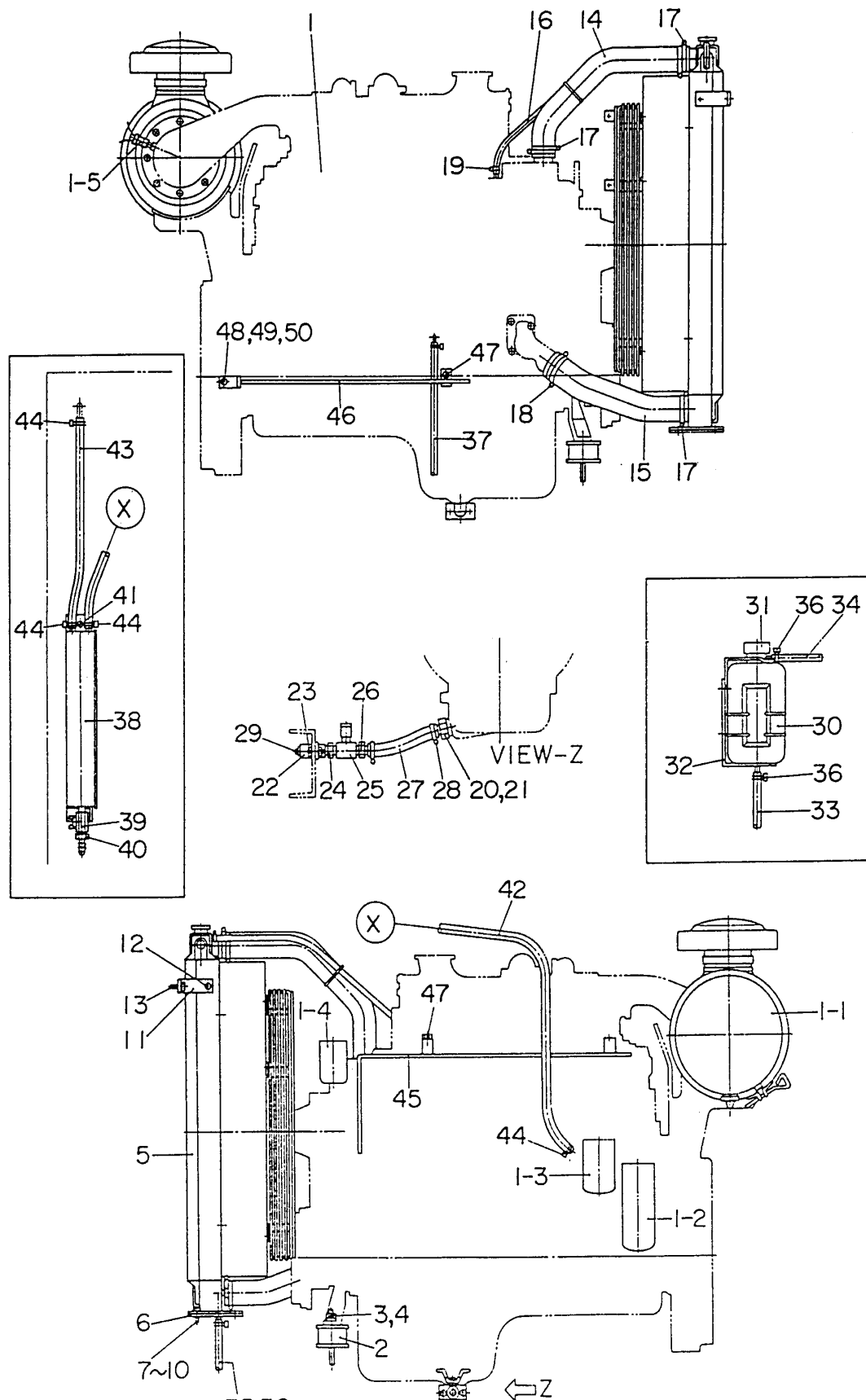

DCA-220SSK — ENGINE & RADIATOR ASSY.

ENGINE & RADIATOR ASSY.

<u>NO.</u>	<u>PART NO.</u>	<u>PART NAME</u>	<u>QTY.</u>	<u>REMARKS</u>
1	C1925200024	ENGINE	1	KOMATSU S6D125E-2
1-1	6125817032	ELEMENT, AIR CLEANER	1	REPLACES 0602040156
1-2	6002111231	CARTRIDGE, FUEL FILTER	1	REPLACES 0602041146
1-3	6003118293	CARTRIDGE, OIL FILTER	1	REPLACES 0602042146
1-4	6004111151	CARTRIDGE, CORROSION RESISTOR	1	REPLACES 0602045143
1-5	0602040678	DUST SENSOR	1	
2	0605000011	RUBBER SUSPENSION	2	
3	0030016000	HEX. NUT	4	
4	0040016000	LOCK WASHER	4	
5	6152619720	RADIATOR	1	REPLACES 0602011946
6	6152619170	RUBBER SHEET	2	REPLACES 0605000490
7	0010112050	HEX. HEAD BOLT	4	
8	0030012000	HEX. NUT	4	
9	0040012000	LOCK WASHER	4	
10	0041212000	PLAIN WASHER	8	
11	8195123104	BRACKET, RADIATOR	2	
12	0017112025	HEX. HEAD BOLT	2	
13	0017110025	HEX. HEAD BOLT	2	
14	6152621520	RADIATOR HOSE	1	REPLACES 0602014513
15	6152611531	RADIATOR HOSE	1	REPLACES 0602014641
16	0726120911	RADIATOR HOSE	1	REPLACES 0602014541
17	0728100809	HOSE BAND	6	REPLACES 0602014067
18	0728100909	HOSE BAND	2	REPLACES 0602014056
19	0728001920	HOSE BAND	2	REPLACES 0602014058
20	3972054104	DRAIN JOINT	1	
21	3972054304	PACKING	1	
22	C9601000104	DRAIN JOINT	1	
23	011208025	HEX. HEAD BOLT	2	REPLACES 0017108025
24	0131508000	NIPPLE, 3/4	1	
25	0603325017	VALVE	1	
26	0602022294	HOSE JOINT	1	

DCA-220SSK — ENGINE & RADIATOR ASSY.

ENGINE & RADIATOR ASSY.

<u>NO.</u>	<u>PART NO.</u>	<u>PART NAME</u>	<u>QTY.</u>	<u>REMARKS</u>
27	0265800240	DRAIN HOSE	1	
28	0605515074	HOSE BAND	2	
29	0132008000	PLUG, 3/4	1	
30	0802081003C	RESERVE TANK	1	REPLACES 0802081003
31	0802010900	CAP, RESERVE TANK	1	REPLACES 0602010900
32	C1317100103	BRACKET, RESERVE TANK	1	
33	0199601300	HOSE	1	
34	0193601300	HOSE	1	
35	0193600550	HOSE	1	
36	0605515013	HOSE BAND	4	
37	0194800750	HOSE	1	
38	C1325100003	OIL MIST TANK	1	S/N3698950~
39	0603325011	VALVE	1	
40	0602022293	HOSE JOINT	1	S/N3698950~
40	0603320111	U BOLT	1	S/N3696501 TO S/N3698949
41	011008020	HEX. HEAD BOLT	2	S/N3698950~ REPLACES 0017108020
41	0207008000	HEX. NUT	2	S/N3696501 TO S/N3698949
42	0268202300	HOSE	1	S/N3698950~
42	C1327100103	BREATHER PIPE	1	S/N3696501 TO S/N3698949
43	0268200650	HOSE	1	
44	0605515074	HOSE BAND	4	S/N3698950~
44	0605515073	HOSE BAND	2	S/N3696501 TO S/N3698949; HS10
45	C1358300814	CLAMPER ROD	1	
46	C1358300104	CLAMPER ROD	1	
47	012210020	HEX. HEAD BOLT	3	REPLACES 0017110020
48	0010016030	HEX. HEAD BOLT	1	
49	0040016000	LOCK WASHER	1	
50	0041216000	PLAIN WASHER	1	

DCA-220SSK — ENGINE OPERATING PANEL ASSY.

ENGINE OPERATING PANEL ASSY.

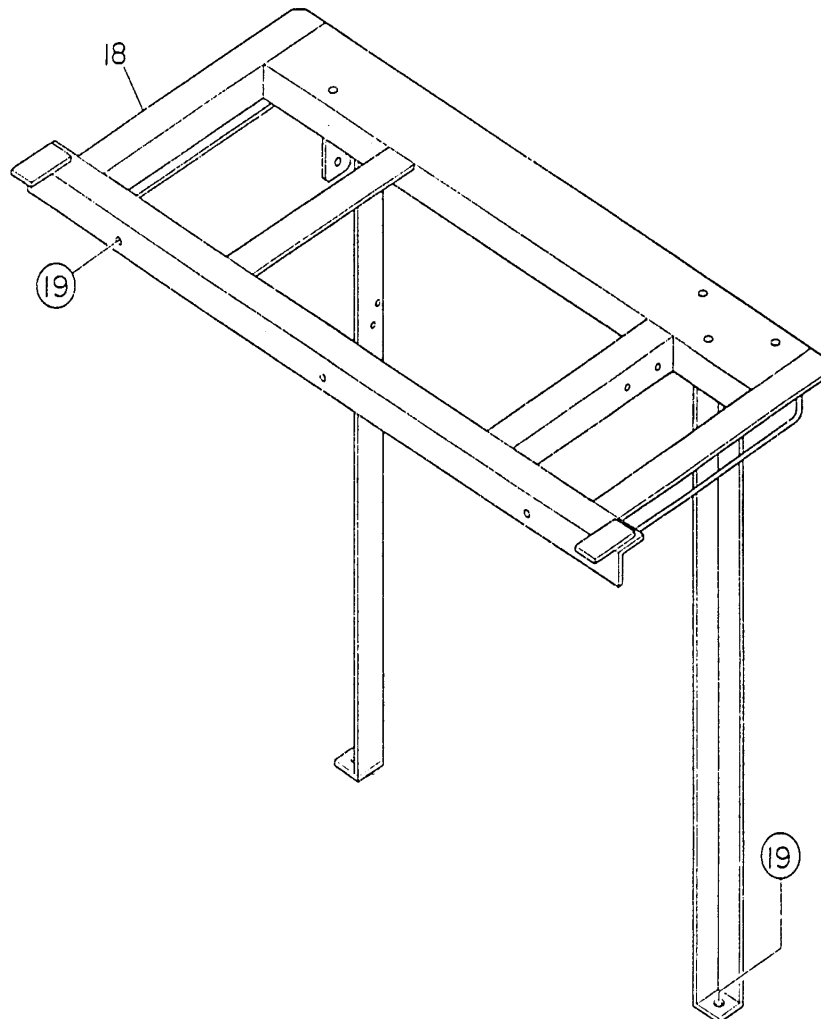
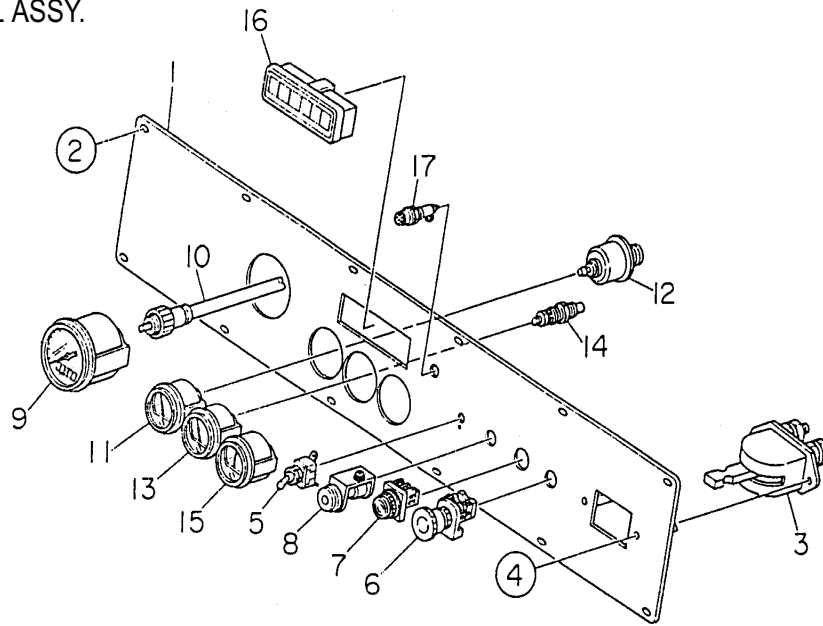

DCA-220SSK — ENGINE OPERATING PANEL ASSY.

ENGINE OPERATING PANEL ASSY.

<u>NO.</u>	<u>PART NO.</u>	<u>PART NAME</u>	<u>QTY.</u>	<u>REMARKS</u>
1	C1353100003	OPERATING PANEL	1	
2	0019106016	HEX. HEAD BOLT	12	
3	0602101000	BATTERY SWITCH	1	9827300090
4	0021008080	MACHINE SCREW	2	
	020108060	HEX. NUT	2	REPLACES 0030008000
	0040008000	LOCK WASHER	2	
	031108160	PLAIN WASHER	4	REPLACES 0041208000
5	0601830710	ENGINE SPEED SWITCH	1	S301T
6	0601831557	EMERGENCY STOP BUTTON	1	AR22V2R01R
7	0601830448	PREHEAT BUTTON	1	AH25FB10
8	6008153730	PREHEAT LAMP	1	REPLACES 0602102055
9	0602120054	TACHOMETER	1	25000KX4110
10	0602120178	CABLE, TACHOMETER	1	62100KX0700 L=2700
11	0602122060	OIL PRESSURE GAUGE	1	42000KX1410
12	0602122200	UNIT, OIL PRESSURE	1	53000AC0101
13	0602123061	WATER TEMPERATURE GAUGE	1	40000KX0910
14	0602123206	UNIT, WATER TEMPERATURE	1	751400KS0600
15	0602121022	CHARGING AMMETER	1	43000KV0300
16	0602115014	MONITOR	1	V3376600000
17	0602103091	DETECTOR LAMP, FUEL LEAK	1	REPLACES 0602103090
	0601810244	BULB	1	
18	C1484000212	SUPPORT LEG	1	
19	012010030	HEX. HEAD BOLT	5	REPLACES 0017110030

DCA-220SSK — GOVERNOR ACTUATOR ASSY.

GOVERNOR ACTUATOR ASSY.

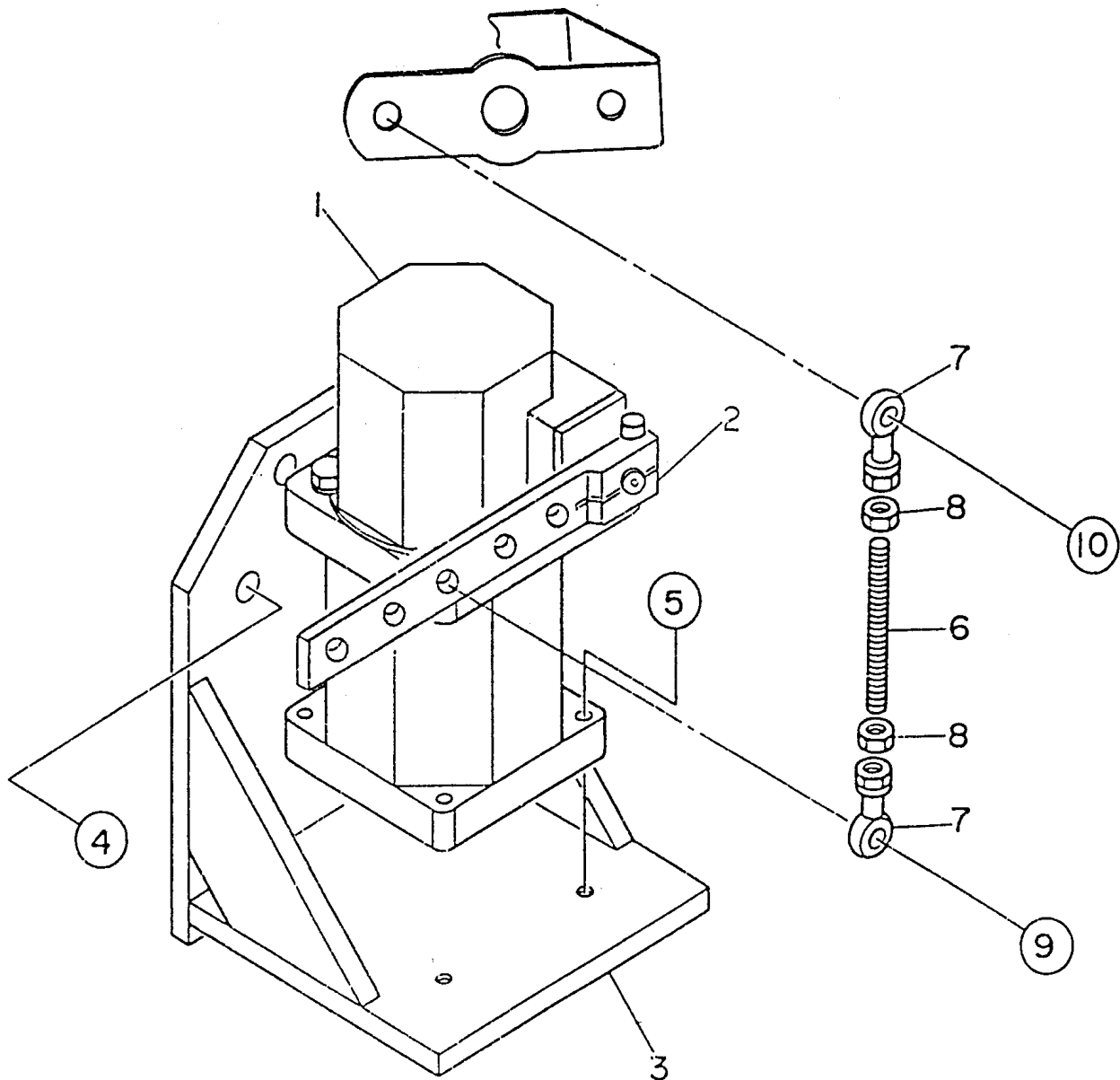

DCA-220SSK — GOVERNOR ACTUATOR ASSY.

GOVERNOR ACTUATOR ASSY.

<u>NO.</u>	<u>PART NO.</u>	<u>PART NAME</u>	<u>QTY.</u>	<u>REMARKS</u>
1	DYNC11024000	ACTUATOR	1	REPLACES 0602150091
2	DYNC182	LEVER	1	REPLACES 0602211090
3	C1356200004	BRACKET, ACTUATOR	1	
4	0012310030	HEX. HEAD BOLT	4	
	0041210000	PLAIN WASHER	4	S/N3696501 TO S/N3698949
5	0010306035	HEX. HEAD BOLT	4	
	0207006000	HEX. NUT	4	
	952404470	PLAIN WASHER	4	REPLACES 0041206000
	0040006000	LOCK WASHER	4	
6	0602211091	ROD	1	
7	0602180190	BALL JOINT, 1/4-28	2	
8	0602211092	HEX. NUT	2	
9	011606025	HEX. HEAD BOLT	1	REPLACES 0010106025
	0207006000	HEX. NUT	1	
	952404470	PLAIN WASHER	1	REPLACES 0041206000
10	011606025	HEX. HEAD BOLT	1	REPLACES 0010106025
	0207006000	HEX. NUT	1	
	031110160	PLAIN WASHER	4	REPLACES 0041210000

DCA-220SSK —OUTPUT TERMINAL ASSY.

OUTPUT TERMINAL ASSY.

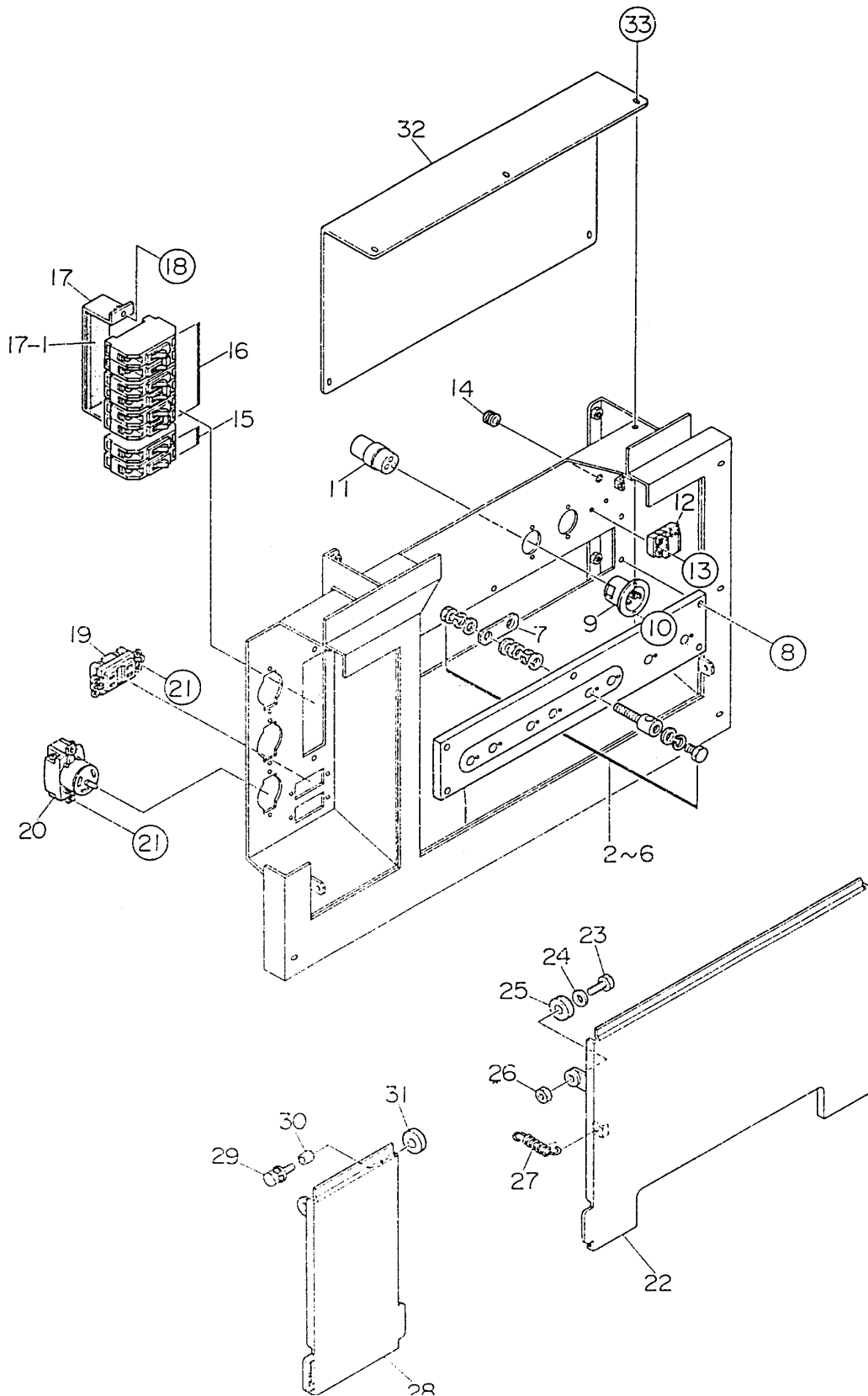

DCA-220SSK —OUTPUT TERMINAL ASSY.

OUTPUT TERMINAL ASSY.

<u>NO.</u>	<u>PART NO.</u>	<u>PART NAME</u>	<u>QTY.</u>	<u>REMARKS</u>
1	C1231700003	SET BOARD, OUTPUT TERMINAL	1	
2	C1278500004	OUTPUT TERMINAL	8	S/N3698950~
2	0801030304	OUTPUT TERMINAL	8	S/N3696501TO S/N3698949
3	0801830904	HEX. HEAD BOLT	8	S/N3698950~
3	0801830804	HEX. HEAD BOLT	8	S/N3696501 TO S/N3698949
	030220510	LOCK WASHER	8	S/N3698950~
				REPLACES 0040020000
	0041420000	PLAIN WASHER	8	S/N3698950~
4	0039316000	HEX. NUT	16	
5	0040016000	LOCK WASHER	16	
6	0041416000	PLAIN WASHER	24	
7	3461860504	TERMINAL PLATE	3	
8	0019108040	HEX. HEAD BOLT	5	
	030208200	LOCK WASHER	5	REPLACES 0042308000
	031108160	PLAIN WASHER	5	REPLACES 0042408000
9	0601811189	RECEPTACLE	2	HBL5378C 125V 20A
10	0027103010	MACHINE SCREW	4	
11	0601812537	ADAPTER	1	HBL5369C 125V 20A
12	0601815324	TERMINAL BOARD	1	
13	0027104020	MACHINE SCREW	2	
14	0601850275	GROMMET	1	
15	0601804887	CIRCUIT BREAKER	2	KM51B 265V 20A
				REPLACES 0601805313
16	0601805840	CIRCUIT BREAKER	3	KM52265V 50A
17	C1261600204	BRACKET, CIRCUIT BREAKER	1	
17-1	0223300200	RUBBER CUSHION	1	
18	011206020	HEX. HEAD BOLT	2	REPLACES 0017106020
19	0601812597	RECEPTACLE	2	GF530EM
				REPLACES 0601812598
20	0601811034	RECEPTACLE	2	CS6369
				REPLACES 0601812565
21	0027104016	MACHINE SCREW	10	
	0030004000	HEX. NUT	10	
	031104080	PLAIN WASHER	10	REPLACES 0041204000
22	C1237100113	COVER, OUTPUT TERMINAL	1	
23	0019112045	HEX. HEAD BOLT	2	
24	0042412000	PLAIN WASHER	2	
25	0805015604	STAY RUBBER	2	
26	0205012000	HEX. NUT	2	
27	0845043704	SPRING	2	
28	C0237101504	COVER	1	
29	014210040	HEX. HEAD BOLT	2	REPLACES 0017110040
30	0845054204	COLLAR	2	
31	0805015604	STAY RUBBER	1	
32	C1237100214	COVER	1	
33	011008020	HEX.HEAD BOLT	7	REPLACES 0017108020

DCA-220SSK — BATTERY ASSY.

BATTERY ASSY.

<u>NO.</u>	<u>PART NO.</u>	<u>PART NAME</u>	<u>QTY.</u>	<u>REMARKS</u>
1	0168614551	BATTERY	2	145G51
2	0805000804	BATTERY SHEET	2	
3	0805000904	BATTERY BAND	2	
4	0805002904	BATTERY BOLT	4	
5	0037808000	WING NUT	4	
6	0041208000	PLAIN WASHER	4	
8	C1347600004	BATTERY CABLE	1	
9	C1347600104	BATTERY CABLE	1	
10	C1347600504	BATTERY CABLE	1	
11	C1347600304	BATTERY CABLE	1	
12	C1347200104	EARTH CABLE	1	
13	0347010030	HEX. HEAD BOLT	4	
14	0208110000	HEX.NUT	4	
15	0845040414	TERMINAL CAP (+)	2	
16	0845041304	TERMINAL CAP (-)	2	
17	0602220203	BATTERY SENSOR	1	REPLACES 0602220204
18	0010110020	HEX. HEAD BOLT	1	
	0040010000	LOCK WASHER	1	
	031110160	PLAIN WASHER	1	REPLACES 0041610000
19	0040510000	TOOTHED WASHER	1	

DCA-220SSK — MUFFLER ASSY.

MUFFLER ASSY.

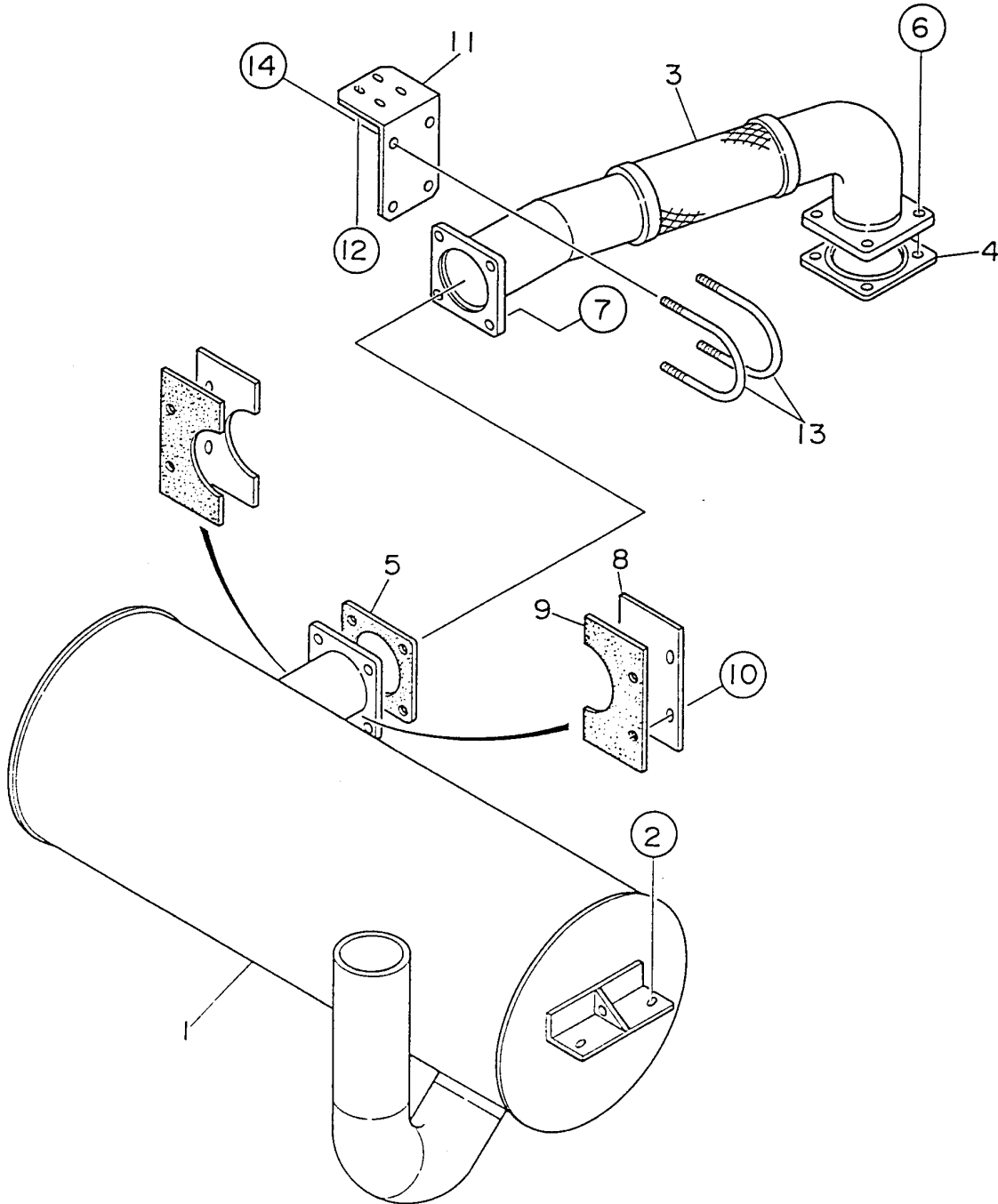

DCA-220SSK — MUFFLER ASSY.

MUFFLER ASSY.

<u>NO.</u>	<u>PART NO.</u>	<u>PART NAME</u>	<u>QTY.</u>	<u>REMARKS</u>
1	C1331100702	MUFFLER	1	
2	0019210025	HEX. HEAD BOLT	4	
3	C1334000403	EXHAUST PIPE	1	
4	150115751	GASKET	1	REPLACES 0602320142
5	C1334200304	GASKET	1	
6	0010312050	HEX. HEAD BOLT	4	
	0030312000	HEX. NUT	4	
	0040012000	LOCK WASHER	4	
	031112230	PLAIN WASHER	8	REPLACES 0041212000
7	0010312055	HEX. HEAD BOLT	4	
	0030312000	HEX NUT	4	
	0040012000	LOCK WASHER	4	
	031112230	PLAIN WASHER	8	REPLACES 0041212000
8	C1331300104	COVER	2	
9	C1334200104	SHEET	2	
10	011008020	HEX. HEAD BOLT	4	REPLACES 0017108020
11	C1334300104	BRACKET	1	
12	011008020	HEX. HEAD BOLT	4	REPLACES 0017108020
13	0603320129	U BOLT	2	
14	0207010000	HEX. NUT	4	

DCA-220SSK — FUEL WATER SEPARATOR ASSY.

FUEL WATER SEPARATOR ASSY.

S/N3698950~

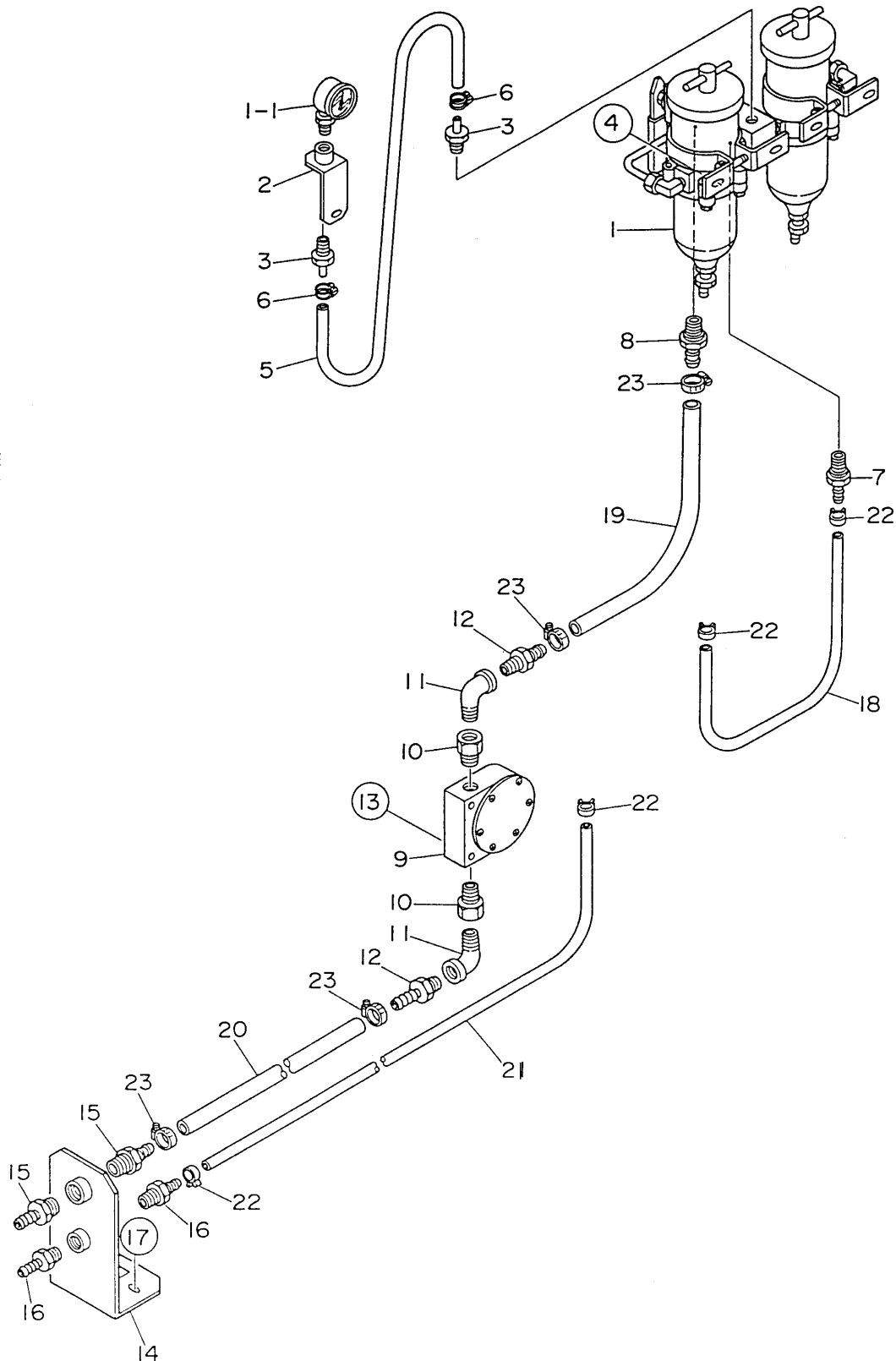

DCA-220SSK — FUEL WATER SEPARATOR ASSY.

FUEL WATER SEPARATOR ASSY. S/N3698950~

<u>NO.</u>	<u>PART NO.</u>	<u>PART NAME</u>	<u>QTY.</u>	<u>REMARKS</u>
1	75500FGX	WATER SEPARATOR	1	REPLACES 0602042270
	R2010PMOR	ELEMENT, WATER SEPARATOR	2	
1-1	RK19476	PRESSURE GAUGE	1	REPLACES 0602130190
2	C036870004	BRACKET, PRESSURE GAUGE	1	
3	C9202000604	HOSE JOINT	2	
4	011008020	HEX. HEAD BOLT	4	REPLACES 0017108020
5	0191000620	HOSE	1	
6	0605515013	HOSE BAND	2	
7	91108H6	HOSE JOINT	1	REPLACES 0602022787
8	91108H10	HOSE JOINT	1	REPLACES 0602022786
9	LGX500	FUEL CONDITIONER	1	REPLACES 0602042490
10	C9202000304	ADAPTER	2	
11	0130206000	STREET ELBOW, 1/2	2	
12	0602022293	HOSE JOINT	2	
13	0017106040	HEX. HEAD BOLT	2	
14	C4368700104	BRACKET	1	
15	0602022284	HOSE JOINT	2	
16	0602022203	HOSE JOINT	2	
17	0017110025	HEX. HEAD BOLT	2	
18	0191300800	SUCTION HOSE	1	
19	0191500600	SUCTION HOSE	1	
20	0191501600	SUCTION HOSE	1	
21	0191302600	RETURN HOSE	1	
22	0605515109	HOSE BAND	4	
23	0605515074	HOSE BAND	4	

DCA-220SSK — FUEL WATER SEPARATOR ASSY.

FUEL WATER SEPARATOR ASSY.

S/N3696501 TO S/N3698949

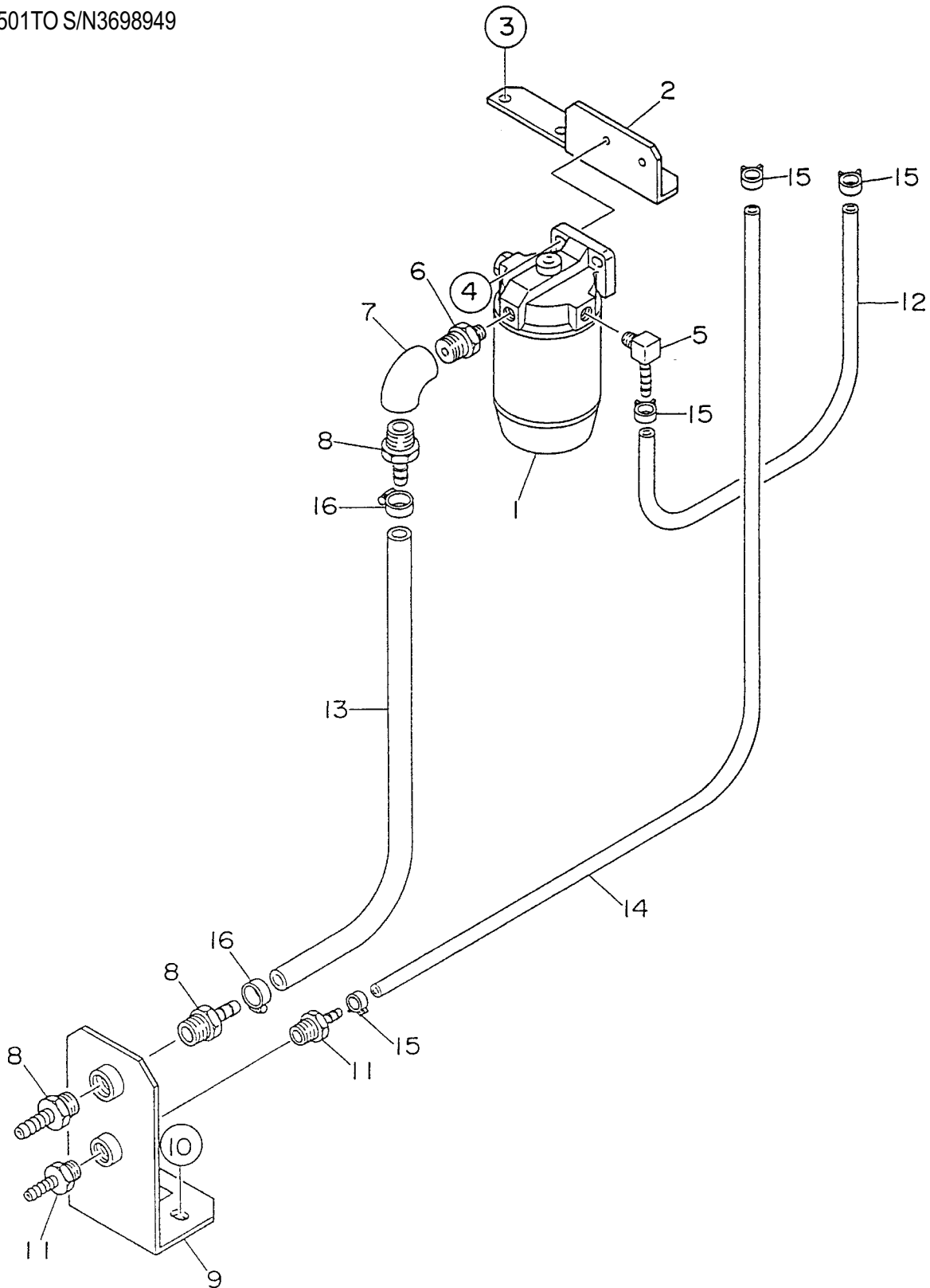

DCA-220SSK — FUEL WATER SEPARATOR ASSY.

FUEL WATER SEPARATOR ASSY. S/N3696501 TO S/N3698949

<u>NO.</u>	<u>PART NO.</u>	<u>PART NAME</u>	<u>QTY.</u>	<u>REMARKS</u>
1	230R	WATER SEPARATOR	1	REPLACES 0602042286
	R30P	ELEMENT, WATER SEPARATOR	1	REPLACES 0602042287
2	C1368700004	BRACKET, WATER SEPARATOR	1	
3	0017110025	HEX. HEAD BOLT	2	
4	0017108030	HEX.HEAD BOLT	2	
5	0603306495	ELBOT JOINT	1	
6	C9202000004	JOINT	1	
7	0130008000	ELBOW JOINT, 3/4	1	
8	0602022284	HOSE JOINT	3	
9	C4368700104	BRACKET	1	
10	0017110025	HEX. HEAD BOLT	2	
11	0602022203	HOSE JOINT	2	
12	0191300600	SUCTION HOSE	1	
13	0191502800	SUCTION HOSE	1	
14	0191302600	RETURN HOSE	1	
15	0605515109	HOSE BAND	4	
16	0605515074	HOSE HAND	2	

DCA-220SSK-JACKET WATER HEATER ASSY.

JACKET WATER HEATER ASSY.

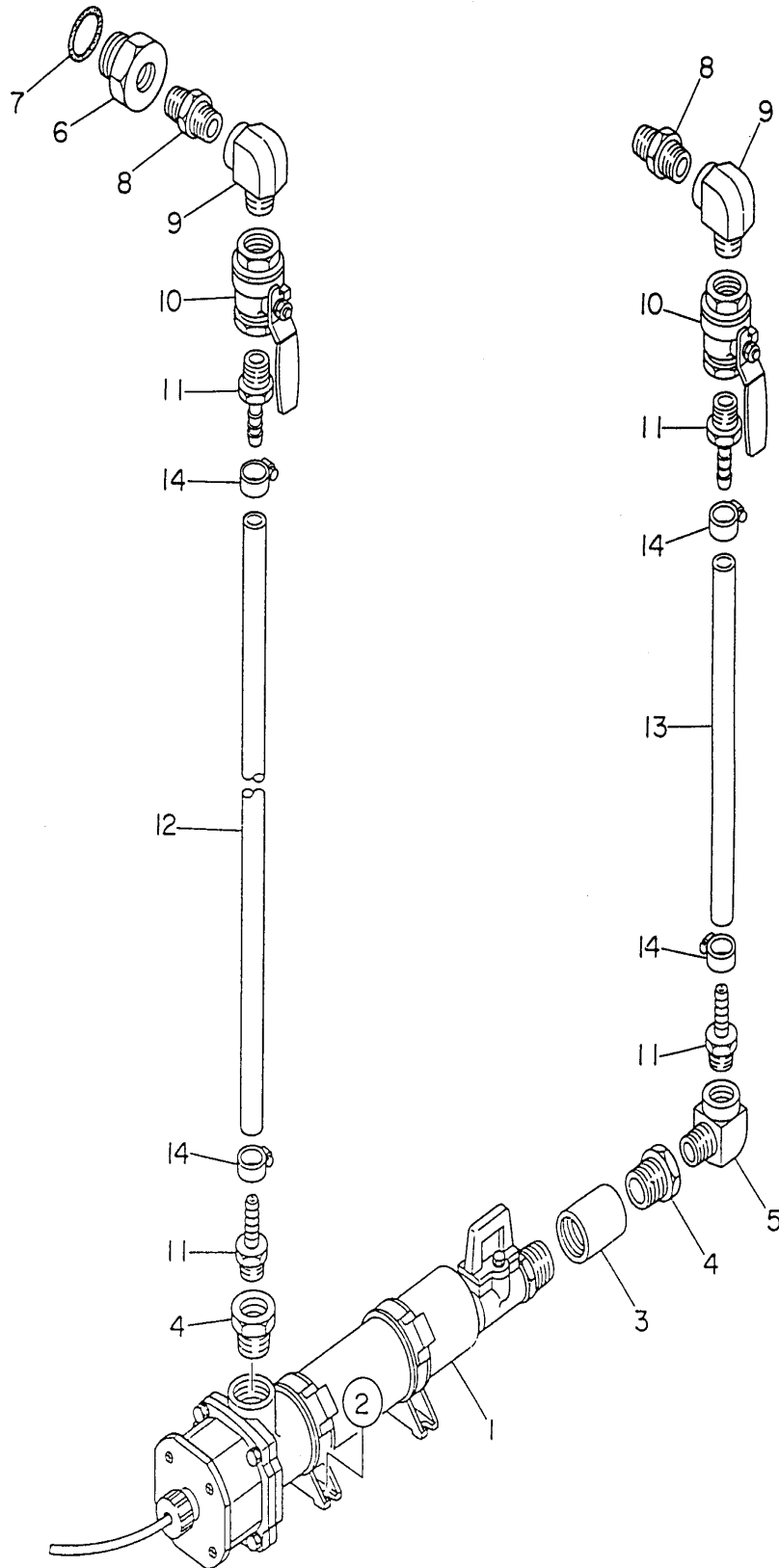

DCA-220SSK-JACKET WATER HEATER ASSY.

JACKET WATER HEATER ASSY.

<u>NO.</u>	<u>PART NO.</u>	<u>PART NAME</u>	<u>QTY.</u>	<u>REMARKS</u>
1	SB1151100000	WATER HEATER	1	REPLACES 0602014293
2	011206020	HEX. HEAD BOLT	4	REPLACES 0017106020
3	0603307690	SOCKET	1	NPT1
4	0603306892	BUSHING	1	NPT1X3/8
5	0603306293	STREET ELBOW	1	3/8
6	C1322700004	ADAPTER	1	
7	6150211190	O RING	1	REPLACES 0602021157
8	0603306312	NIPPLE	2	
9	0603306223	STREET ELBOW	2	
10	0603325076	VALVE	2	
11	0602022292	HOSE JOINT	4	
12	C1322700104	HOSE	1	S/N3698950~
12	0265700700	HOSE	1	S/N3696501 TO S/N3698949
13	C1322700204	HOSE	1	S/N3698950~
13	0265700600	HOSE	1	S/N3696501 TO S/N3698949
14	0605515074	HOSE BAND	4	

DCA-220SSK — ENCLOSURE ASSY.

ENCLOSURE ASSY.

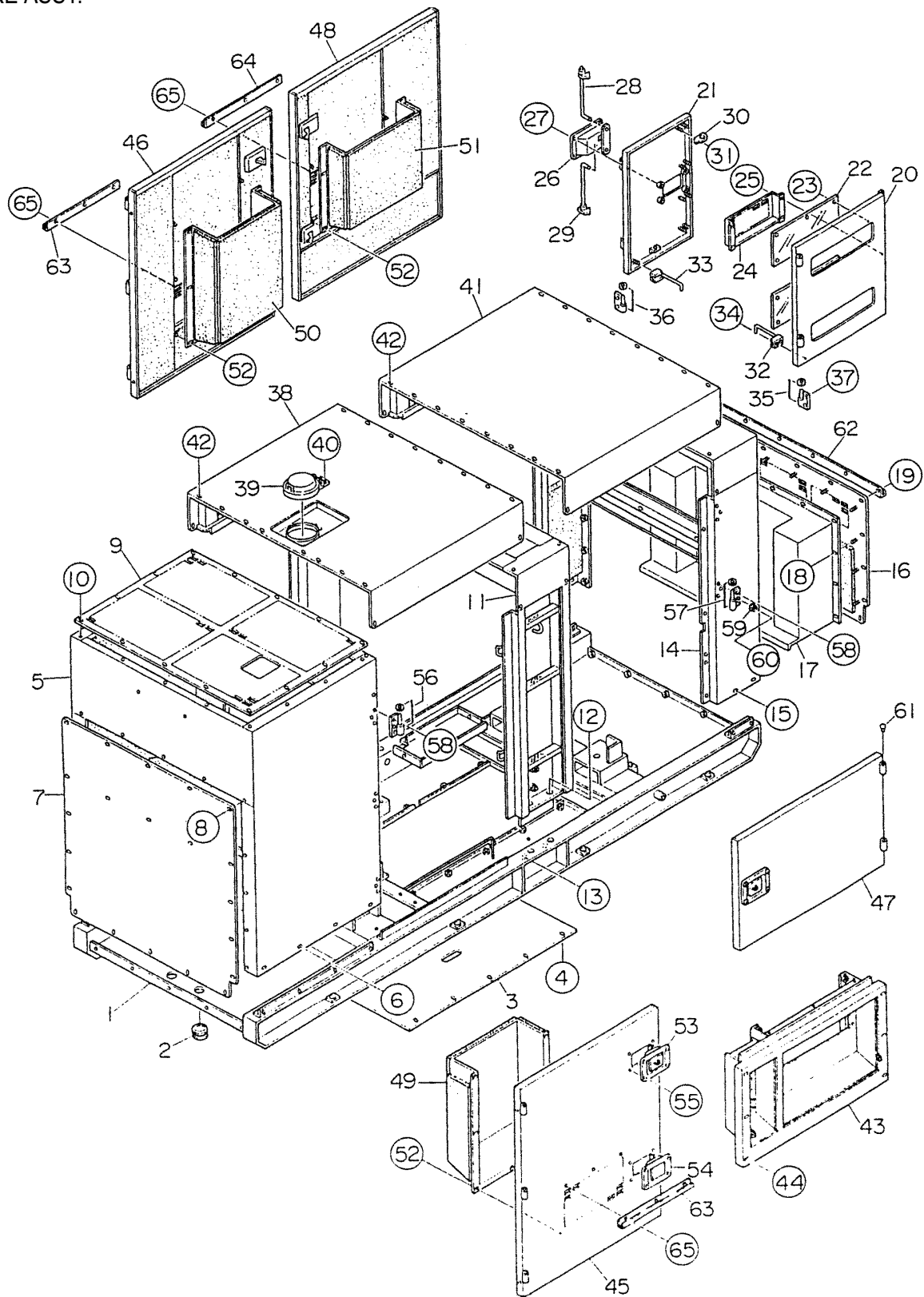

DCA-220SSK — ENCLOSURE ASSY.

ENCLOSURE ASSY.

<u>NO.</u>	<u>PART NO.</u>	<u>PART NAME</u>	<u>QTY.</u>	<u>REMARKS</u>
1	C1415000022	BASE	1	S/N3699127 TO S/N3699149 S/N3699620 TO S/N3699636
1	C1415000012	BASE	1	S/N3698950 TO S/N3699126
1	C1415000002	BASE	1	S/N3696501 TO S/N3698949
	C1494000104	LINING	2	
2	0601851733	GROMMET	2	
3	C3414100004	FLOOR PANEL	1	
4	011008020	HEX. HEAD BOLT	10	REPLACES 0019208020
5	C1425000002	FRONT FRAME	1	S/N3698950~
	C1495100003	LINING	1	S/N3698950~
5	C1424000602	FRONT FRAME	1	S/N3696501 TO S/N3698949
	C1494100403	LINING	1	S/N3696501 TO S/N3698949
6	0019210025	HEX. HEAD BOLT	8	
7	C1425200004	COVER, FRONT FRAME	1	
	8175924104	LINING	1	
8	011008020	HEX. HEAD BOLT	21	REPLACES 0019208020
9	C1424200503	COVER, FRONT FRAME	1	
10	011008020	HEX. HEAD BOLT	14	REPLACES 0019208020
11	C1435000002	CENTER FRAME	1	S/N3698950~
11	C1434000202	CENTER FRAME	1	S/N3696501 TO S/N3698949
12	0010114050	HEX. HEAD BOLT	4	
	020114110	HEX. NUT	4	REPLACES 0030014000
	030214350	LOCK WASHER	4	REPLACES 0040014000
	031114260	PLAIN WASHER	8	REPLACES 0041214000
13	0010120050	HEX. HEAD BOLT	4	
	0030020000	HEX. NUT	4	
	030220510	LOCK WASHER	4	REPLACES 0040020000
	0041220000	PLAIN WASHER	8	
14	C1444000412	REAR FRAME	1	
	C1494300504	LINING	2	
15	0019210025	HEX. HEAD BOLT	4	
16	C1444300403	COVER, REAR FRAME	1	
	C1494300304	LINING	1	
17	C1444300303	DUCT	1	
	C1494300404	LINING	1	
18	020108060	HEX. NUT	12	REPLACES 0207008000
19	011008020	HEX. HEAD BOLT	17	REPLACES 0019208020
20	C1444200103	DOOR, REAR FRAME	1	
21	8175143303	DOOR, REAR FRAME	1	
22	8225147004	WINDOW PLATE	2	
23	020106050	HEX. NUT	12	REPLACES 0037906000
24	B9114500104	DOOR POCKET	1	
25	0207006000	HEX. NUT	4	

ADD THE FOLLOWING LETTERS AFTER THE PART NUMBER WHEN ORDERING ANY PAINTED PANEL TO INDICATE COLOR OF UNIT:

MQW- WHITE
MQG-GREY

THE SERIAL NUMBER MAY BE REQUIRED.

DCA-220SSK — ENCLOSURE ASSY.

ENCLOSURE ASSY.

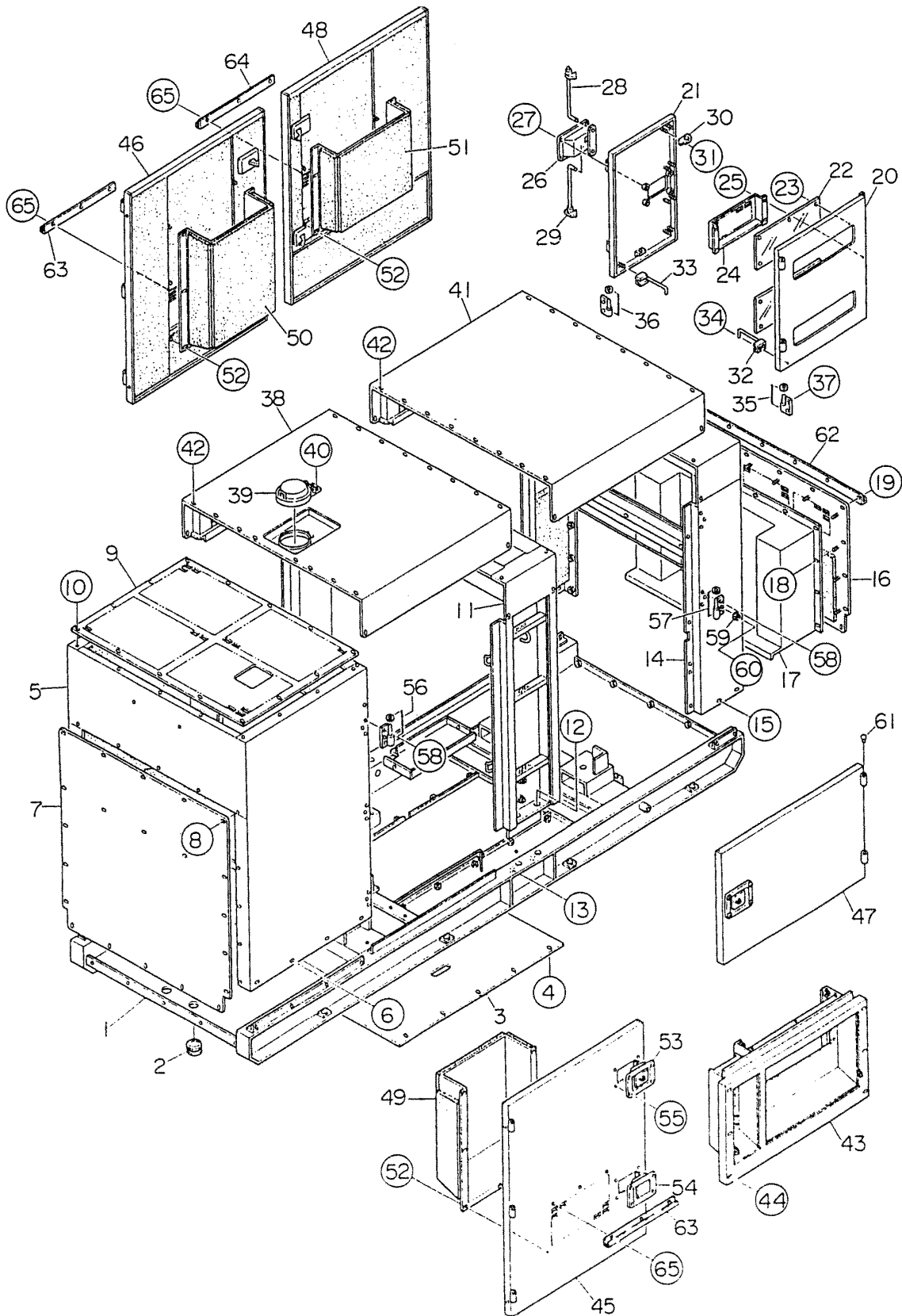

DCA-220SSK — ENCLOSURE ASSY.

ENCLOSURE ASSY.

<u>NO.</u>	<u>PART NO.</u>	<u>PART NAME</u>	<u>QTY.</u>	<u>REMARKS</u>
26	B9114000102	DOOR HANDLE	1	
27	0021806016	MACHINE SCREW	4	
	020106050	HEX. NUT	4	REPLACES 0030006000 S/N3698950 TO S/N3699126
28	8175146204	DOOR ROD	1	
29	8175146304	DOOR ROD	1	
30	0845050704	STAY	4	
31	0205006000	HEX. NUT	8	
	0042306000	LOCK WASHER	8	
	0042406000	PLAIN WASHER	8	
32	0805011304	STOPPER, DOOR	1	
33	0805011204	STOPPER, DOOR	1	
34	0207006000	HEX. NUT	4	
35	M911060204	HINGE	2	REPLACES 0845047104
	0845045004	WASHER	2	
36	M9110100304	HINGE	2	REPLACES 0845047204
	0845045004	WASHER	2	
37	011008020	HEX. HEAD BOLT	6	REPLACES 0019208020
38	C1465100002	ROOF PANEL	1	S/N3698950~
	C1495500004	LINING	1	S/N3698950~
38	C1464100102	ROOF PANEL	1	S/N3696501 TO S/N3698949
	C1494500204	LINING	1	S/N3696501 TO 3698949
39	0800251701	FILLER COVER	1	
40	0025006016	MACHINE SCREW	2	
	0042306000	LOCK WASHER	2	
	0042406000	PLAIN WASHER	2	
41	C1464200002	ROOF PANEL	1	
	C1494500004	LINING	1	
42	011008020	HEX. HEAD BOLT	40	REPLACES 0019208020
	C0044508019	SEAL WASHER	40	S/N3699127 TO S/N3699149 S/N3699620 TO S/N3699636
43	C1455200002	SPLASHER PANEL	1	
44	0019108065	HEX.HEAD BOLT	6	S/N3696501 TO S/N3699126
44	0019108070	HEX. HEAD BOLT	6	S/N3699127 TO S/N3699149 S/N3699620 TO S/N3699636
	030208200	LOCK WASHER	6	REPLACES 0042308000
	031108160	PLAIN WASHER	6	REPLACES 0042408000
	0044508019	SEAL WASHER	6	S/N3699127 TO S/N3699149 S/N3699620 TO S/N3699636

ADD THE FOLLOWING LETTERS AFTER THE PART NUMBER WHEN ORDERING ANY PAINTED PANEL TO INDICATE COLOR OF UNIT:

MQW- WHITE
MQG-GREY

THE SERIAL NUMBER MAY BE REQUIRED.

DCA-220SSK — ENCLOSURE ASSY.

ENCLOSURE ASSY.

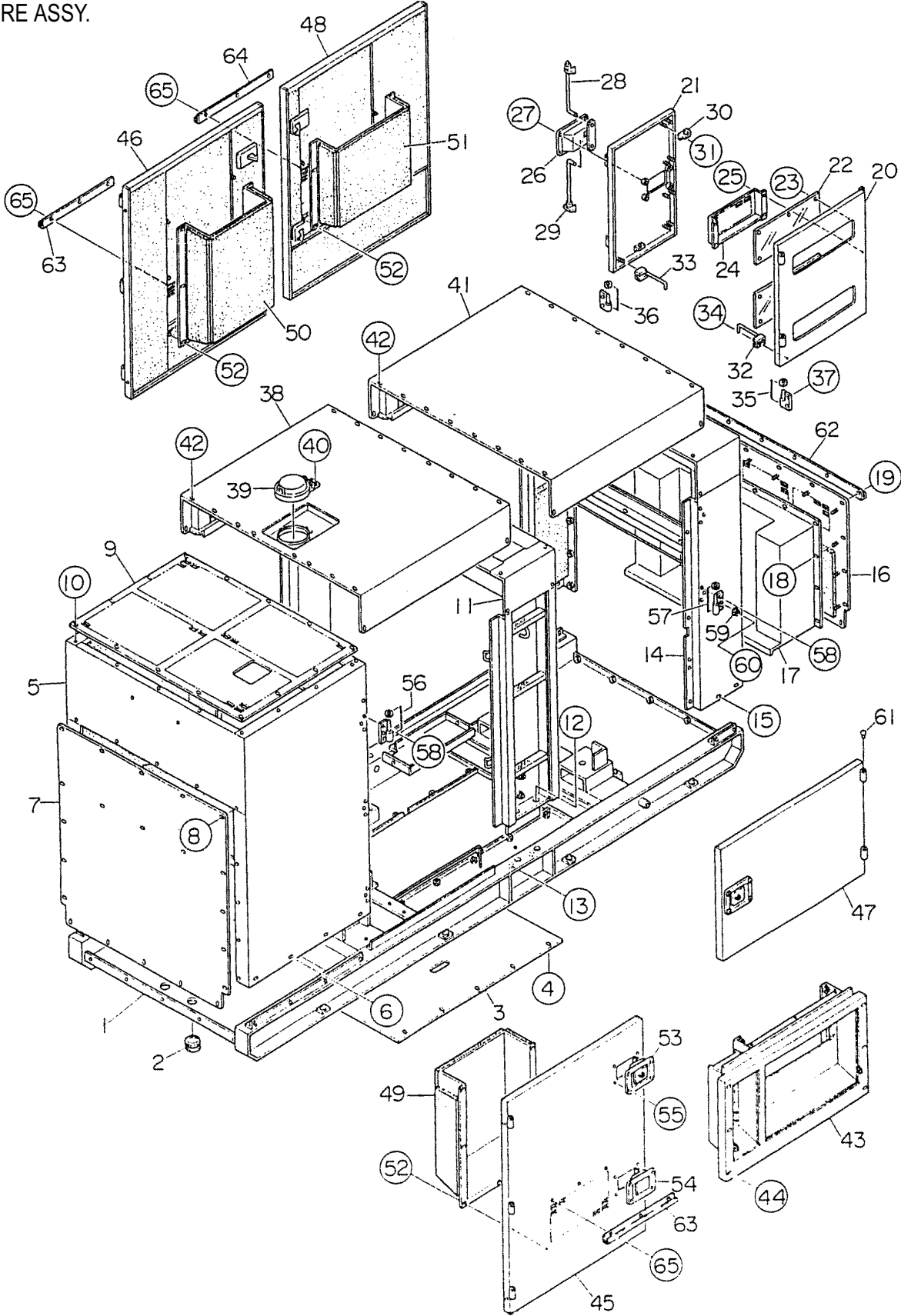

DCA-220SSK — ENCLOSURE ASSY.

<u>NO.</u>	<u>PART NO.</u>	<u>PART NAME</u>	<u>QTY.</u>	<u>REMARKS</u>
45	C1454000903	SIDE DOOR	1	S/N3696501 TO 3699126
45	C1455000503	SIDE DOOR	1	S/N3699127 TO S/N3699149 S/N3699620 TO S/N3699636
	C1494401604	LINING	1	
46	C1454001003	SIDE DOOR	1	S/N3696501 TO S/N3699126
46	C1455000603	SIDE DOOR	1	S/N3699127 TO S/N3699149 S/N3699620 TO S/N3699636
	C1494401704	LINING	1	
47	C1454001203	SIDE DOOR	1	
	C1494401804	LINING	1	
48	C1454001103	SIDE DOOR	1	S/N3696501 TO S/N3699126
48	C1455000703	SIDE DOOR	1	S/N3699127 TO S/N3699149 S/N3699620 TO S/N3699636
	C1494401904	LINING	1	
49	C1454300604	DUCT	1	
	C1494402904	LINING	1	
50	C1454300604	DUCT	1	
	C1494402104	LINING	1	
51	C1454300704	DUCT	1	
	C1494402004	LINING	1	
52	020108060	HEX. NUT	19	REPLACES 0207008000
53	B9114000002	DOOR HANDLE	4	
	C9312500004	RUBBER SEAL	4	S/N3699127 TO S/N3699149 S/N3699620 TO S/N3699636
54	0825007362	DOOR HANDLE	3	
	C931250004	RUBBER SEAL	3	S/N3699127 TO S/N3699149 S/N3699620 TO S/N3699636
55	0021806016	MACHINE SCREW	28	
	020106050	HEX. NUT	28	REPLACES 0030006000 S/N3696501 TO S/N3699126
56	0845046904	HINGE	6	
	0845045004	WASHER	6	
57	0845047004	HINGE	5	
	0845045004	WASHER	5	
58	011008020	HEX. HEAD BOLT	25	REPLACES 0019208020
59	0601850097	STOPPER	10	
60	011208025	MACHINE SCREW	10	REPLACES 0021008025
61	0845031504	CAP	15	
62	C1445500004	COVER BRACKET	1	S/N3699127 TO S/N3699149 S/N3699620 TO S/N3699636
63	C1455600104	DOOR BRACKET	2	S/N3699127 TO S/N3699149 S/N3699620 TO S/N3699636
64	C1455600004	DOOR BRACKET	1	S/N3699127 TO S/N3699149 S/N3699620 TO S/N3699636
65	0021906016	MACHINE SCREW	9	S/N3699127 TO S/N3699149 S/N3699620 TO S/N3699636

ADD THE FOLLOWING LETTERS AFTER THE PART NUMBER WHEN ORDERING ANY PAINTED PANEL TO INDICATE COLOR OF UNIT:

MQW- WHITE
MQG-GREY

THE SERIAL NUMBER MAY BE REQUIRED.

DCA-220SSK-RUBBER SEAL ASSY.

RUBBER SEALS ASSY.

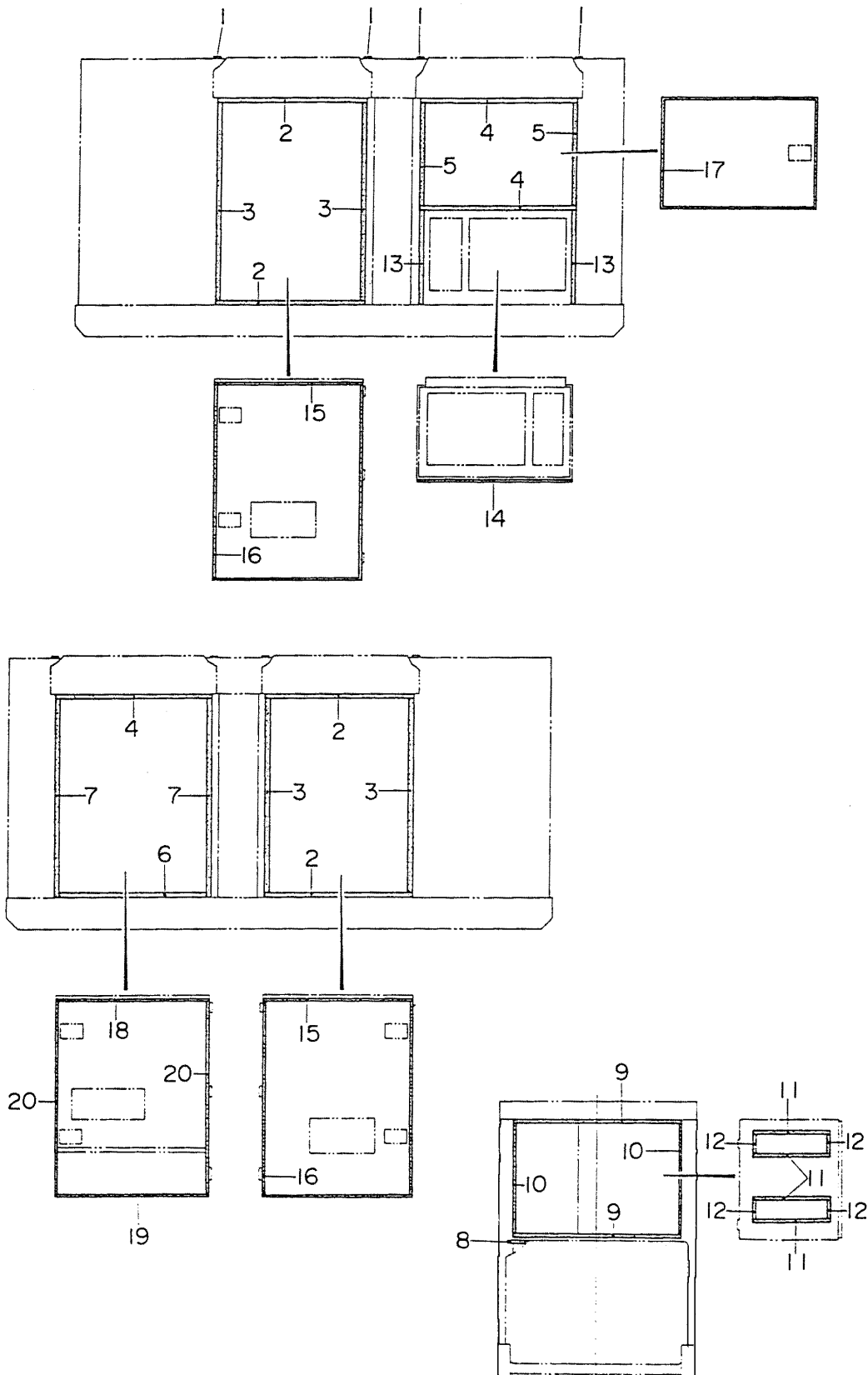

DCA-220SSK-RUBBER SEAL ASSY.

RUBBER SEALS ASSY.

<u>NO.</u>	<u>PART NO.</u>	<u>PART NAME</u>	<u>QTY.</u>	<u>REMARKS</u>
1	0229201300	RUBBER SEAL	4	
2	0228901010	RUBBER SEAL	4	
3	0228901250	RUBBER SEAL	4	
4	0228901050	RUBBER SEAL	3	
5	0228900650	RUBBER SEAL	2	
6	0229200950	RUBBER SEAL	1	
7	0228901280	RUBBER SEAL	2	
8	0229201200	RUBBER SEAL	1	
9	0228801100	RUBBER SEAL	2	
10	0221200760	RUBBER SEAL	2	
11	0228100510	RUBBER SEAL	4	
12	0228100120	RUBBER SEAL	4	
13	0229200600	RUBBER SEAL	2	S/N3699127 TO S/N3699149 S/N3699620 TO S/N3699636
14	0229201040	RUBBER SEAL	1	S/N3699127 TO S/N3699149 S/N3699620 TO S/N3699636
15	0226900990	RUBBER SEAL	2	S/N3699127 TO S/N3699149 S/N3699620 TO S/N3699636
16	0226903525	RUBBER SEAL	2	S/N3699127 TO S/N3699149 S/N3699620 TO S/N3699636
17	0226903440	RUBBER SEAL	1	S/N3699127 TO S/N3699149 S/N3699620 TO S/N3699636
18	0226901030	RUBBER SEAL	1	S/N3699127 TO S/N3699149 S/N3699620 TO S/N3699636
19	0220301030	RUBBER SEAL	1	S/N3699127 TO S/N3699149 S/N3699620 TO S/N3699636
20	0226901270	RUBBER SEAL	2	S/N3699127 TO S/N3699149 S/N3699620 TO S/N3699636

DCA-220SSK-DECALS ASSY.

DECALS ASSY.

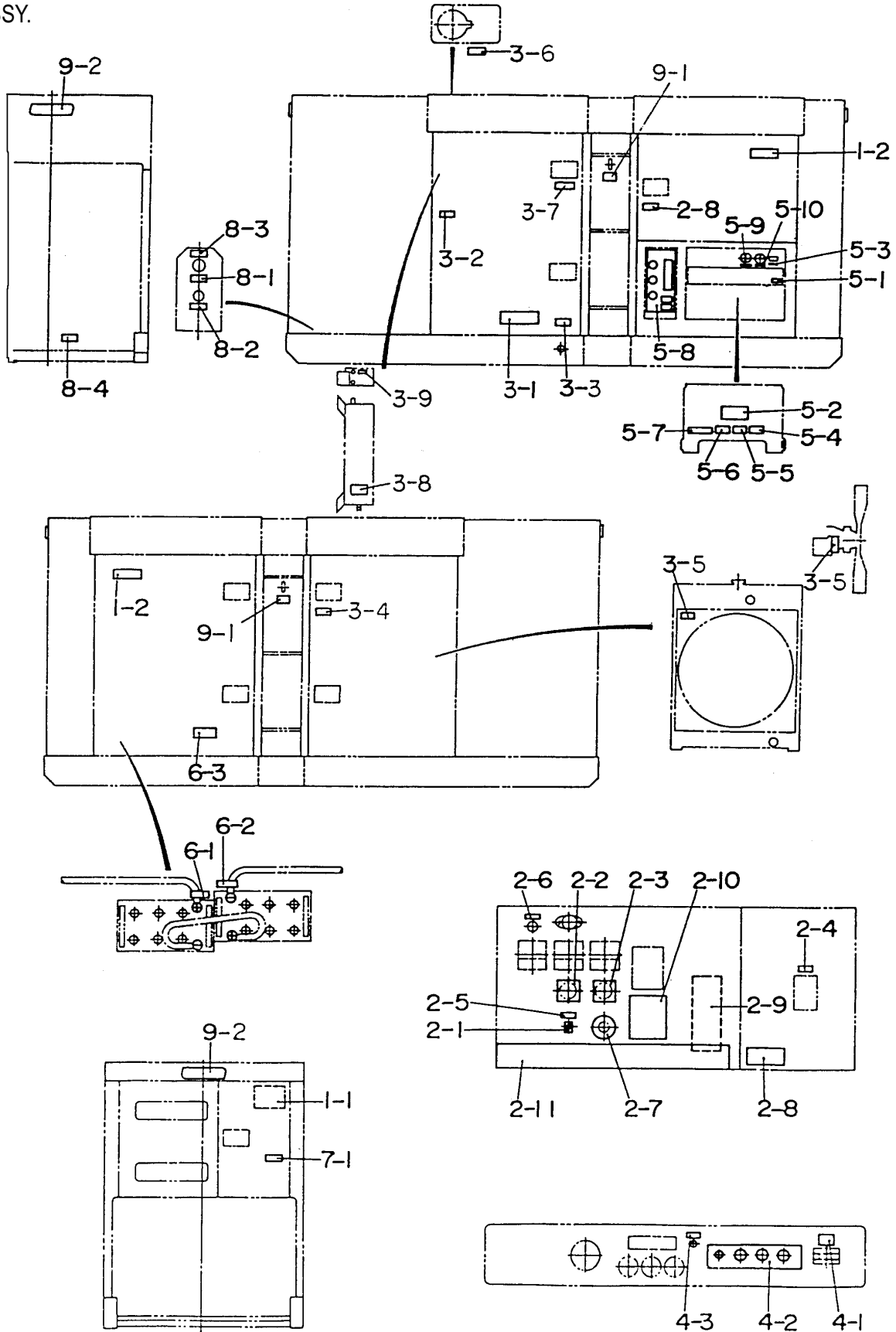

DECALS ASSY.

<u>NO.</u>	<u>PART NO.</u>	<u>PART NAME</u>	<u>QTY.</u>	<u>REMARKS</u>
1-1	C1552000403	DECAL; HANDLING PROCEDURES	1	C15200040
1-2	B1552000103	DECAL; CAUTION	2	B15200010
<u>CONTROL BOX GROUP</u>				
2-1	0800520100	DECAL; ON-OFF	1	AT-202
2-2	0800520904	PLATE; AMMETER CHANGE- OVER SWITCH	1	N- 2438
2-3	0800520814	PLATE; VOLTMETER CHANGE- OVER SWITCH	1	N- 2439
2-4	0840624504	DECAL; CIRCUIT BREAKER	1	S- 3031
2-5	0840624604	DECAL; PANEL LIGHT SWITCH	1	S- 3032
2-6	0840624704	DECAL; PILOT LAMP	1	S- 3033
2-7	0840624804	DECAL; VOLTAGE REGULATOR	1	S- 3034
2-8	B9531100604	DECAL; WARNING ELECTRIC SHOCK HAZARD	2	B9311 0060
2-9	C0551000903	DECAL; SETTING FOR OUTPUT VOLTAGE	1	C0510 0090
2-10	C2551000004	DECAL; SAFETY INSTRUCTIONS	1	C2510 0000
2-11	C0561101603	DECAL; WHISPERWATT 220	1	C1611 0160
<u>ENGINE & RADIATOR GROUP</u>				
3-1	1320610603	DECAL; WATER - OIL	1	S/N 3698950~ S- 1760
3-2	6360610304	DECAL; WATER	1	S- 1880
3-3	6360620204	DECAL; OIL DRAIN PLUG	1	S- 1885
3-4	B9504000304	DECAL; CAUTION HOT PARTS	1	S/N 3698950~ B9040 0040
3-5	B9504000404	DECAL; WARNING MOVING PARTS	2	B9040 0040
3-6	B9504100104	DECAL; WARNING HOT COOLANT	1	B9041 0010
3-7	C9542200004	DECAL; BLOW-BY OIL MIST DRAIN DAILY	1	S/N 3698950~ C9422 0000
3-8	C9542200104	DECAL; BLOW-BY OIL MIST TANK	1	S/N 3698950~ C9422 0010
3-9	C9542200204	DECAL; INLET	1	C9422 0020
<u>ENGINE OPERATING PANEL GROUP</u>				
4-1	C0551000504	DECAL; BATTERY SWITCH	1	C0510 0050
4-2	C1552000013	DECAL; OPERATING PANEL	1	C1520 0001
4-3	C1552000104	DECAL; FUEL LEAK DETECTED	1	C1520 0010
<u>OUTPUT TERMINAL GROUP</u>				
5-1	0840614104	DECAL; GROUND	1	S- 2635
5-2	0840619904	DECAL; DANGER HIGH VOLTAGE	1	S- 2731
5-3	9039209064	DECAL; START CONTACT	1	S- 4468
5-4	B9511100304	DECAL; WARNING	1	B9111 0030
5-5	B9511100404	DECAL; WARNING ELECTRIC SHOCK HAZARD	1	B9111 0040
5-6	B9531100504	DECAL; WARNING ELECTRIC SHOCK HAZARD	1	B9311 0050
5-7	C0551000404	DECAL; 3- PHASE OUTPUT TERMINAL	1	C0510 0040

DCA-220SSK-DECALS ASSY.

DECALS ASSY.

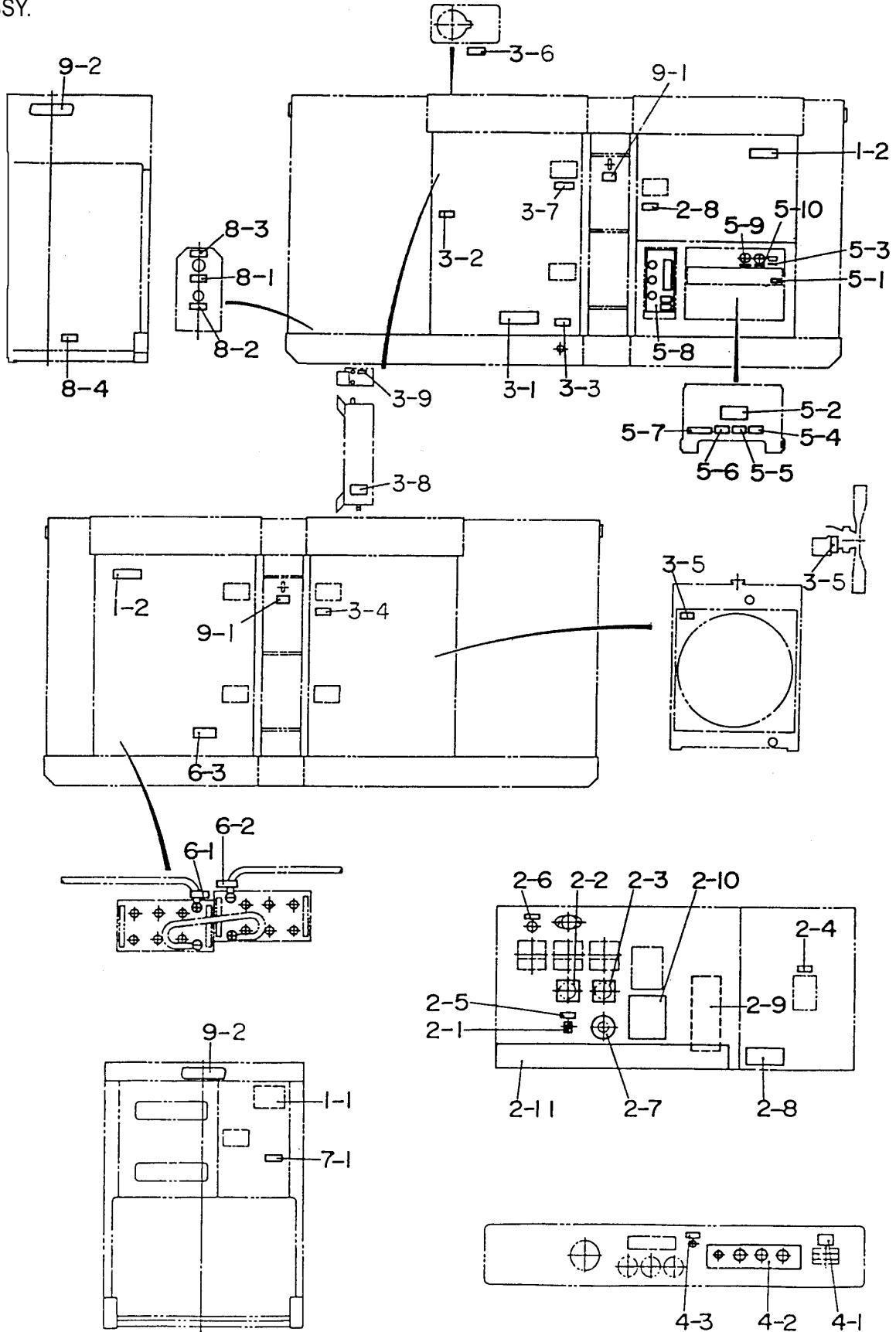

DCA-220SSK-DECALS ASSY.

DECALS ASSY.

<u>NO.</u>	<u>PART NO.</u>	<u>PART NAME</u>	<u>QTY.</u>	<u>REMARKS</u>
5-8	C0551001503	DECAL; RECEPTACLE & CIRCUIT BREAKER	1	C0510 0150
5-9	C1552000204	DECAL; WATER HEATER	1	C1520 0020
5-10	C1552000304	DECAL; BATTERY CHARGER	1	C1520 0030
<u>BATTERY GROUP</u>				
6-1	0800689404	DECAL; +	1	S- 2090
6-2	0800689504	DECAL; -	1	S- 2091
6-3	C9595300004	DECAL; CAUTION	1	C9053 0000
<u>MUFFLER GROUP</u>				
7-1	B9504200004	DECAL; WARNING ENGINE EXHAUST	1	B9042 0000
<u>FUEL PIPING GROUP</u>				
8-1	0800688404	DECAL; FUEL INLET	1	S- 1344
8-2	0800688504	DECAL; FUEL OUTLET	1	S- 1345
8-3	1320620904	DECAL; DIESEL FUEL	1	S- 1756
8-4	B9504500004	DECAL; WARNING DIESEL FUEL	1	B9045 0000
<u>BONNET GROUP</u>				
9-1	1320621504	DECAL; SUPPORT HOOK	2	S- 2257
9-2	0600500090	EMBLEM	2	
	0021106016	MACHINE SCREW	4	

PAYMENT TERMS

Terms of payment for parts are net 10 days.

FREIGHT POLICY

All parts orders will be shipped collect or prepaid with the charges added to the invoice. All shipments are F.O.B. point of origin. Multiquip's responsibility ceases when a signed manifest has been obtained from the carrier, and any claim for shortage or damage must be settled between the consignee and the carrier.

MINIMUM ORDER

The minimum charge for orders from Multiquip is \$15.00 net. Customers will be asked for instructions regarding handling of orders not meeting this requirement.

RETURNED GOODS POLICY

Return shipments will be accepted and credit will be allowed, subject to the following provisions:

1. A Returned Material Authorization must be approved by Multiquip prior to shipment.
2. To obtain a Return Material Authorization, a list must be provided to Multiquip Parts Sales that defines item numbers, quantities, and descriptions of the items to be returned.
 - a. The parts numbers and descriptions must match the current parts price list.
 - b. The list must be typed or computer generated.
 - c. The list must state the reason(s) for the return.
 - d. The list must reference the sales order(s) or invoice(s) under which the items were originally purchased.
 - e. The list must include the name and phone number of the person requesting the RMA.
3. A copy of the Return Material Authorization must accompany the return shipment.

4. Freight is at the sender's expense. All parts must be returned freight prepaid to Multiquip's designated receiving point.
5. Parts must be in new and resalable condition, in the original Multiquip package (if any), and with Multiquip part numbers clearly marked.
6. The following items are not returnable:
 - a. Obsolete parts. (If an item is listed in the parts price book as being replaced by another item, it is obsolete.)
 - b. Any parts with a limited shelf life (such as gaskets, seals, "O" rings, and other rubber parts) that were purchased more than six months prior to the return date.
 - c. Any line item with an extended dealer net price of less than \$5.00.
 - d. Special order items.
 - e. Electrical components.
 - f. Paint, chemicals, and lubricants.
 - g. Decals and paper products.
 - h. Items purchased in kits.
7. The sender will be notified of any material received that is not acceptable.
8. Such material will be held for 5 working days from notification, pending instructions. If a reply is not received within 5 days, the material will be returned to the sender at his expense.
9. Credit on returned parts will be issued at dealer net price at time of the original purchase, less a 15% restocking charge.
10. In cases where an item is accepted for which the original purchase document can not be determined, the price will be based on the list price that was effective twelve months prior to the RMA date.
11. Credit issued will be applied to future purchases only.

PRICING AND REBATES

Prices are subject to change without prior notice. Price changes are effective on a specific date and all orders received on or after that date will be billed at the revised price. Rebates for price declines and added charges for price increases will not be made for stock on hand at the time of any price change.

Multiquip reserves the right to quote and sell direct to Government agencies, and to Original Equipment Manufacturer accounts who use our products as integral parts of their own products.

SPECIAL EXPEDITING SERVICE

A \$20.00 to \$50.00 surcharge will be added to the invoice for special handling including bus shipments, insured parcel post or in cases where Multiquip must personally deliver the parts to the carrier.

LIMITATIONS OF SELLER'S LIABILITY

Multiquip shall not be liable here under for damages in excess of the purchase price of the item with respect to which damages are claimed, and in no event shall Multiquip be liable for loss of profit or good will or for any other special, consequential or incidental damages.

LIMITATION OF WARRANTIES

No warranties, express or implied, are made in connection with the sale of parts or trade accessories nor as to any engine not manufactured by Multiquip. Such warranties made in connection with the sale of new, complete units are made exclusively by a statement of warranty packaged with such units, and Multiquip neither assumes nor authorizes any person to assume for it any other obligation or liability whatever in connection with the sale of its products. A part from such written statement of warranty, there are no warranties, express, implied or statutory, which extend beyond the description of the products on the face hereof.

PARTS AND OPERATION MANUAL

HERE'S HOW TO GET HELP

*PLEASE HAVE THE MODEL AND SERIAL NUMBER
ON-HAND WHEN CALLING*

PARTS DEPARTMENT

800/427-1244 or 310/537-3700

FAX: 800/672-7877 or 310/637-3284

SERVICE DEPARTMENT

800/835-2551 or 310/537-3700

FAX: 310/638-8046

WARRANTY DEPARTMENT

800/835-2551 or 310/537-3700

FAX: 310/638-8046

MAIN

800/421-1244 or 310/537-3700

FAX: 310/537-3927

Manufactured for Multiquip Inc.
by
DENYO MANUFACTURING, CO., USA



MULTIQUIP INC.

POST OFFICE BOX 6254

CARSON, CA 90749

310-537-3700 • 800-421-1244

FAX: 310-537-3927

E-MAIL: mq@multiquip.com

WWW: multiquip.com

Atlanta • Boise • Dallas • Houston • Newark
Quebec, Canada • Manchester, UK • Rio De Janeiro, BR • Guadalajara, MX