

# APPLICATION & INSTALLATION MANUAL

## MQ POWER Industrial Generator Sets

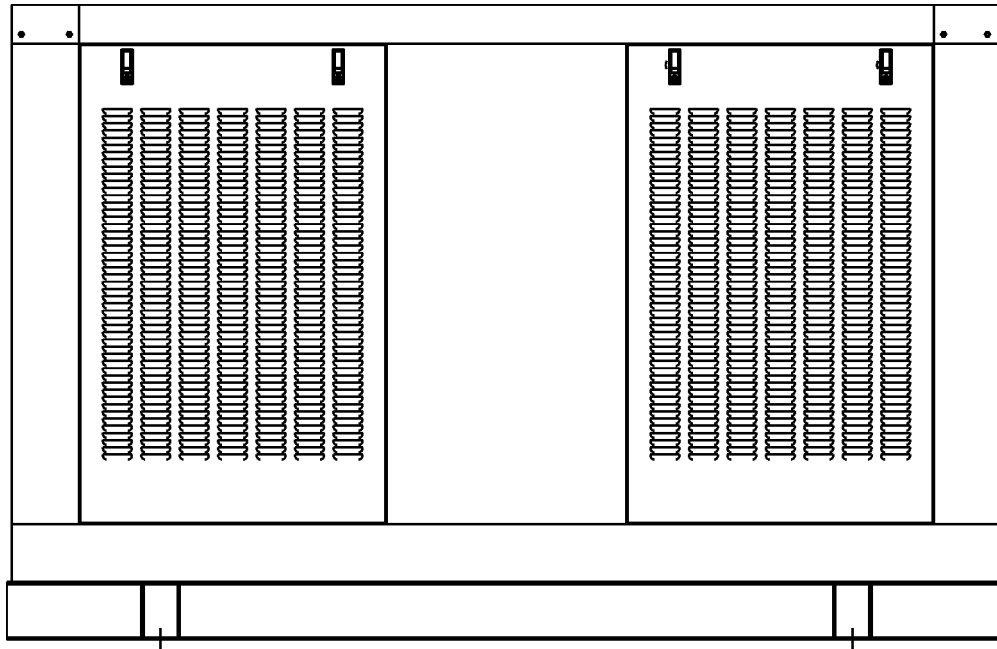

© COPYRIGHT 2004, MULTIQIP INC.

Revision #1 (02/27/04)



### MQPOWER

*A Division of Multiquip Inc.*

POST OFFICE BOX 6254

CARSON, CA 90749

310-537-3700 • 800-421-1244

FAX: 310-632-2656

E-MAIL: [mqpower@multiquip.com](mailto:mqpower@multiquip.com)

WWW: [www.mqpower.com](http://www.mqpower.com)

### PARTS DEPARTMENT:

800-427-1244

FAX: 800-672-7877

### SERVICE DEPARTMENT:

800-835-2551

FAX: 310-638-8046



# **WARNING**



**CALIFORNIA — Proposition 65 Warning**

**Diesel engine exhaust and some of its constituents are known to the State of California to cause cancer, birth defects and other reproductive harm.**

### **DISCLAIMER STATEMENT**

MQ Power publishes the technical information in this manual as an aid to its customers and to the public. The information included in this manual is based on sound engineering principles, research, extensive field experience, and technical judgments. This mater is subject to change in light of developments in technology and field experience. Use or adoption of the information contained in this manual is voluntary. MQ Power disclaims any warranties or guaranties, express or implied, in connection with the information in this manual.

## **HERE'S HOW TO GET HELP**

PLEASE HAVE THE MODEL AND SERIAL  
NUMBER *ON-HAND* WHEN CALLING

### ***MULTIQUIP'S MAIN PHONE NUMBERS***

800-421-1244      FAX: 310-537-3927  
310-537-3700

### ***PARTS DEPARTMENT***

800-427-1244      FAX: 800-672-7877  
310-537-3700      FAX: 310-637-3284

### ***MAYCO PARTS***

800-306-2926      FAX: 800-672-7877  
310-537-3700      FAX: 310-637-3284

### ***SERVICE DEPARTMENT***

800-478-1244      FAX: 310-537-4259  
310-537-3700

### ***MQ POWER SERVICE DEPARTMENT***

800-835-2551      FAX: 310-638-8046  
310-537-3700

### ***TECHNICAL ASSISTANCE***

800-478-1244      FAX: 310-631-5032

### ***WARRANTY DEPARTMENT***

800-421-1244, EXT. 279      FAX: 310-537-1173  
310-537-3700, EXT. 279

Proposition 65 California Warning ..... 2  
 Here's How To Get Help ..... 3  
 Table Of Contents ..... 4  
 Safety Message Alert Symbols ..... 6-7  
 Important Safety Instructions ..... 8-13  
 Introduction ..... 14  
 Installation Overview ..... 15-16

## Application

Genset Sizing ..... 17-21  
 Determining Load Characteristics ..... 22-26  
 Environmental Consideration — dB(A) ..... 27-32

## Mechanical Installation

Mounting Foundation ..... 33-34  
 Mounting Genset ..... 35  
 Mounting — Vibration Isolators ..... 36  
 Fuel System ..... 37-41  
 Exhaust System ..... 42-45  
 Battery System ..... 46-47  
 Installing New Battery ..... 48-49  
 Testing Battery ..... 50-51  
 Charging Battery ..... 52-55

## Ventilation and Cooling

Ventilation and Cooling ..... 56-57  
 Mounted Radiator Cooling ..... 58-59  
 Remote Radiator Cooling ..... 60-61  
 Hot Well Cooling ..... 62  
 Heat Exchanger Cooling ..... 63  
 Coolant Treatment ..... 64

## Electrical Installation

DC Control Wiring ..... 65  
 Control Box Back Panel ..... 66-67  
 AC Electrical Connections ..... 68-71  
 System Grounding ..... 72  
 Equipment Grounding ..... 73  
 Electrical Distribution System ..... 74  
 Pre-Start Preparation ..... 75

## Appendix

Installation Checklist ..... 76  
 Table 19, Main-Line Circuit Breakers ..... 77  
 Table 20, Engine Specifications ..... 78-81  
 Table 21, Dimension and Weights ..... 82-83  
 Table 22, Generator Specifications ..... 84-85

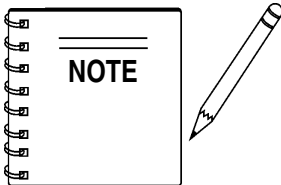

*All specifications in this manual are subject to change without notice.*



# SAFETY MESSAGE ALERT SYMBOLS

## FOR YOUR SAFETY AND THE SAFETY OF OTHERS!

Safety precautions should be followed at all times when installing or operating this equipment. Failure to read and understand the Safety Messages and Installation Instructions could result in injury to yourself and others.

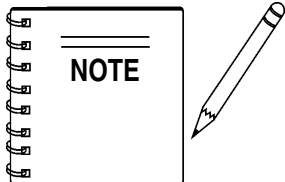

This genset Installation Manual has been developed to provide complete instructions for the safe implementation of MQ Power Gensets for field installation. Depending on the power plant you have selected, please refer to the

engine manufacturers instructions for data relative to its safe operations.

**Before installing any MQ Power Genset, ensure that all authorized personnel has read and understands all installation or operating instructions referenced in this manual.**

## SAFETY MESSAGE ALERT SYMBOLS

The three (3) Safety Messages shown below will inform you about potential hazards that could injure you or others. The Safety Messages specifically address the level of exposure to the operator, and are preceded by one of three words: **DANGER**, **WARNING**, or **CAUTION**.

### **DANGER**

You **WILL** be **KILLED** or **SERIOUSLY INJURED** if you **DO NOT** follow these directions.

### **WARNING**

You **CAN** be **KILLED** or **SERIOUSLY INJURED** if you **DO NOT** follow these directions.

### **CAUTION**

You **CAN** be **INJURED** if you **DO NOT** follow these directions.

Potential hazards associated with MQ Power Gensets field installation will be referenced with Hazard Symbols which appear throughout this manual, and will be referenced in conjunction with Safety Message Alert Symbols.

## HAZARD SYMBOLS

### **Lethal Exhaust Gases**



Engine exhaust gases contain poisonous carbon monoxide. This gas is colorless and odorless, and can cause death if inhaled. **NEVER** operate this equipment in a confined area or enclosed structure that does not provide ample free flow air.

### **Explosive Fuel**

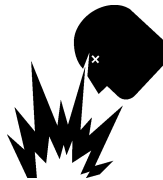

Diesel fuel is extremely flammable, and its vapors can cause an explosion if ignited. **DO NOT** start the engine near spilled fuel or combustible fluids. **DO NOT** fill the fuel tank while the engine is running or hot. **DO NOT** overfill tank, since spilled fuel could ignite if it comes into contact with hot engine parts or sparks from the ignition system. Store fuel in approved containers, in well-ventilated areas and away from sparks and flames. **NEVER** use fuel as a cleaning agent.

### **Burn Hazards**



Engine components can generate extreme heat. To prevent burns, **DO NOT** touch these areas while the engine is running or immediately after operations. **NEVER** operate the engine with heat shields or heat guards removed.

### **Rotating Parts**

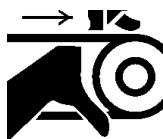

**NEVER** operate equipment with covers, or guards removed. Keep fingers, hands, hair and clothing away from all moving parts to prevent injury.

# SAFETY MESSAGE ALERT SYMBOLS



## Accidental Starting



**OFF** **ALWAYS** place the ignition switch or genset starting device in the **OFF** position, remove key and/or disconnect the battery before servicing the engine or equipment.



## Respiratory Hazard

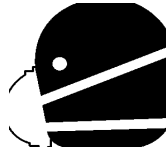

**ALWAYS** wear approved respiratory protection.



## Over Speed Conditions



**NEVER** tamper with the factory settings of the engine governor or settings. Personal injury and damage to the engine or equipment can result if operating in speed ranges above maximum allowable.



## Sight and Hearing hazard

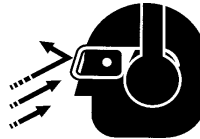

**ALWAYS** wear approved eye and hearing protection.



## Guards and Covers In Place

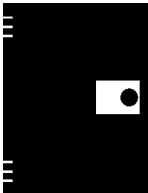

**NEVER** operate the genset without guards and covers in place.



## Equipment Damage Messages

Other important messages are provided throughout this manual to help prevent damage to your genset, other property, or the surrounding environment.

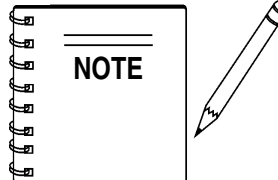

This MQ Power Genset, other property, or the surrounding environment could be damaged if you **DO NOT** follow instructions.

# IMPORTANT SAFETY INSTRUCTIONS

**SAVE THESE INSTRUCTIONS** — This manual contains important safety instructions for MQ Power Industrial generators that should be followed during installation, operation, and maintenance of the engine-generator set.

## CAUTION

Failure to follow instructions in this manual may lead to serious injury or even death! This equipment is to be operated by trained and qualified personnel only! This equipment is for industrial use only.

### GENERAL SAFETY

■ **DO NOT** install, operate, or service this equipment before reading this entire manual along with the operation manual.



■ **NEVER** operate this equipment without proper protective clothing, shatterproof glasses, steel-toed boots and other protective devices required by the job.

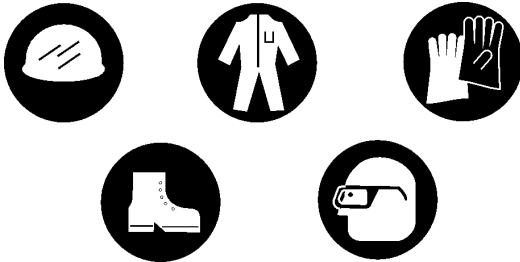

■ **NEVER** operate this equipment when not feeling well due to fatigue, illness or taking medicine.



■ **NEVER** operate this equipment under the influence of drugs or alcohol.



■ **NEVER** touch the hot exhaust manifold, muffler or cylinder. Allow these parts to cool before servicing engine or generator.



■ **High Temperatures** – Allow the engine to cool before adding fuel or performing service and maintenance functions. Contact with *hot* components can cause serious burns.

■ The engine of this generator requires an adequate free flow of cooling air. Never operate the generator in any enclosed or narrow area where free flow of the air is restricted. If the air flow is restricted it will cause serious damage to the generator or engine and may cause injury to people. The generator engine gives off **DEADLY** carbon monoxide gas.

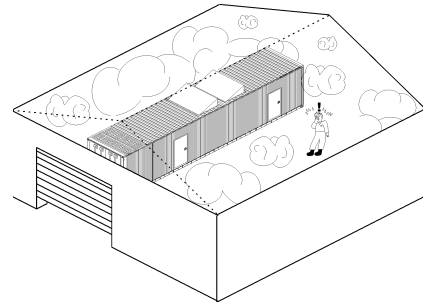

**NEVER** operate the genset in a restricted air flow environment!

## DANGER

■ **DO ALWAYS** refuel in a well-ventilated area, away from sparks and open flames. Fire or explosion could result from fuel vapors, causing severe bodily harm even **death!**

## DANGER

■ **DO NOT** smoke around or near the machine. Fire or explosion could result from fuel vapors, or if fuel is spilled on a hot engine, causing severe bodily harm even **death!**



## DANGER

■ **ALWAYS** use extreme caution when working with **flammable** liquids. When refueling, **stop the engine** and allow it to cool.



■ **NEVER** operate the generator in an explosive atmosphere or near combustible materials. An explosion or fire could result causing severe *bodily harm or even death!*

■ Topping-off to filler port is dangerous, as it tends to spill fuel.

# IMPORTANT SAFETY INSTRUCTIONS

## GENERAL SAFETY

### ⚠ CAUTION

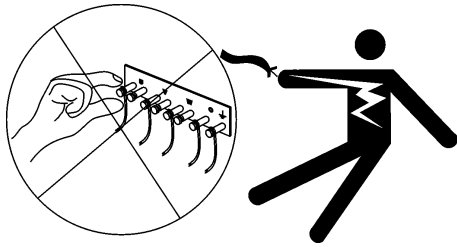

■ **NEVER** touch output terminals during operation. This is extremely dangerous. Always stop the machine and disconnect the battery when contact with the output terminals is necessary.

### ⚠ DANGER

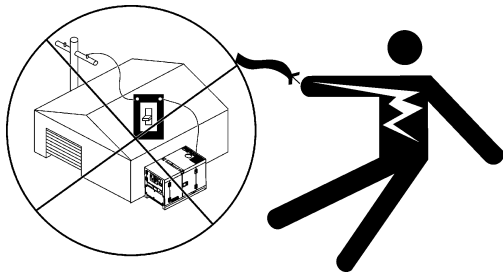

■ **NEVER** connect the generator to house wiring. This is illegal and very dangerous. Electrical shock could occur causing damage to the generator and bodily harm even **death!**

### ⚠ DANGER

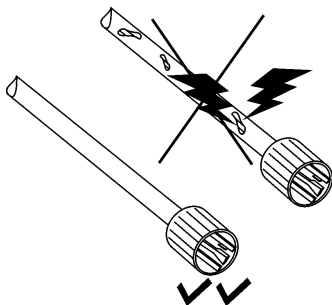

■ **NEVER** use damaged or worn cables when connecting power tools or equipment to the generator. Make sure power connecting cables are securely connected to the generator's output terminals, insufficient tightening of the terminal connections may cause arcing and damage the generator. Touching worn or frayed electrical cables may cause electrical shock, which could result in severe bodily harm or even **death!**

## RADIATOR

### ⚠ CAUTION

■ **DO NOT** touch or open any of the components mentioned below while the generator is running. Always allow sufficient time for the engine and generator to cool before performing maintenance.

1. **Radiator Cap** - Removing the radiator cap while the engine is hot will result in high pressurized, boiling water or coolant to gush out of the radiator, causing severe scalding to any persons in the general area of the generator.

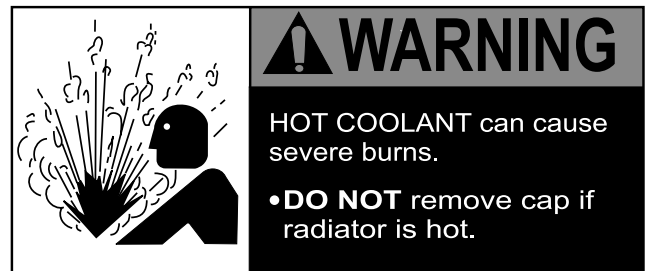

2. **Coolant Drain Plug** - Removing the coolant drain plug while the engine is hot will result in hot coolant to drain out of the coolant drain plug, and could cause severe scalding to any persons in the general area of the generator.
3. **Engine Oil Drain Plug** - Removing the engine oil drain plug while the engine is hot will result in hot oil to drain out of the oil drain plug, and could cause severe scalding to any persons in the general area of the generator.

# IMPORTANT SAFETY INSTRUCTIONS

## Operation Safety

- **ALWAYS** be sure the operator is familiar with proper safety precautions and operations techniques before using generator.
- **DO NOT** allow unauthorized people near equipment.
- **ALWAYS** wear ear protection when working in a loud environment. 
- **NEVER** run engine without air filter. Engine damage will occur.
- **DO NOT** leave the generator running in the MANUAL mode unattended.
- **NEVER** use accessories or attachments, which are not recommended by MQ Power for this equipment. Damage to the equipment and/or injury to user may result.
- Manufacturer does not assume responsibility for any accident due to equipment modifications.
- **ALWAYS** check the machine for loosened parts or bolts before starting.

## Emergencies

Always be prepared for an emergency such as fire, personnel injury, or other emergency situation. It is important to identify all possible emergency situations and to provide adequate prevention methods and response methods.

- Install the appropriate fire extinguishers in convenient locations. Consult the local fire department for the correct type of extinguisher to use. **DO NOT** use foam on electrical fires. Use extinguishers that are rated ABC by NFPA.

- **ALWAYS** know the location of the nearest **fire extinguisher**.



- **ALWAYS** know the location of the nearest **first aid kit**.



- **ALWAYS** provide an emergency escape route in the event of an emergency.

- In emergencies **always** know the location of the nearest phone or **keep a phone on the job site**. Also know the phone numbers of the nearest **ambulance**, **doctor** and **fire department**. This information will be invaluable in the case of an emergency.

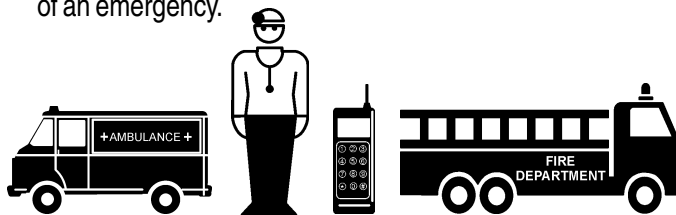

## Maintenance Safety

When performing maintenance on MQ Power generator sets, it is important to prevent automatic start-up of the unit by a remote contact closure by disconnecting the engine battery before servicing.



Always disconnect the battery cable negative (first) before performing service on the generator. Reconnect battery cable negative (last) after service is complete.

- Keep the machinery in proper running condition.
- **NEVER** lubricate components or attempt service on a running machine.
- Always allow the machine a proper amount of time to cool before servicing.
- Fix damage to the machine immediately and always replace broken parts.
- Dispose of hazardous waste properly. Examples of potentially hazardous waste are used motor oil, coolant, fuel, and fuel filters.
- **DO NOT** use plastic containers to dispose of hazardous waste.
- **DO NOT** pour waste, oil, coolant or fuel directly onto the ground, down a drain, or into any water source
- Whenever necessary, replace nameplate, operation and safety decals when they become difficult read.
- Never leave rags or tools on or near the generator-set.
- Refer to the **Volvo Engine Owner's Manual** for engine technical questions or information.

# IMPORTANT SAFETY INSTRUCTIONS

## Battery Safety

The battery is a major component of the engine-generator set. The genset will not start without a properly maintained battery. Disconnecting the battery prevents the engine from starting. Always observe the following safety guidelines when interaction with the battery is necessary:

1. Wear full eye protection and protective clothing when handling battery.
2. In case the battery liquid (dilute sulfuric acid) comes in contact with **clothing or skin**, rinse skin immediately with plenty of water and discard clothing.
3. In case the battery liquid (dilute sulfuric acid) comes in contact with your **eyes**, rinse eyes immediately with plenty of water for fifteen minutes, then contact the nearest doctor or hospital, and seek medical attention.
4. Spilled electrolyte is to be washed down with an acid neutralizing agent. A common practice is to use a solution of one pound (500 grams) bicarbonate of soda to one gallon (4 liters) of water. The bicarbonate of soda solution is to be added until the evidence of reaction (foaming) has ceased. The resulting liquid is to be flushed with water and the area dried.
5. **DO NOT** expose the battery to open flames, sparks, cigarettes etc. The battery contains combustible gases and liquids. If these gases and liquids come in contact with a flame or spark, an explosion could occur.
6. **DO NOT** drop the battery. There is the possibility of risk that the battery may explode.
7. **ALWAYS** discharge static electricity from the body before touching batteries by first touching a grounded metal surface.
8. **ALWAYS** keep the battery charged. If the battery is not charged a buildup of combustible gas will occur.
9. **ALWAYS** keep battery charging and booster cables in good working condition. Repair or replace all worn cables.
10. **ALWAYS** recharge the battery in an open air environment, to avoid risk of a dangerous concentration of combustible gases.
11. Only use a battery that is in proper working condition. Replace battery as recommended by manufacturer.

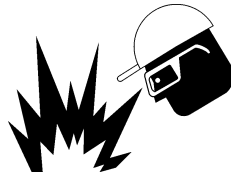

## CAUTION

The battery contains electrolyte which is a dilute sulfuric acid that is harmful to the skin and eyes. Electrolyte is electrically conductive and very corrosive.

## CAUTION

The installation of the engine-generator set must provide enough ventilation to ensure that gases generated by vented batteries during charging, or caused by equipment malfunction are removed. **Lead-acid batteries present a risk of fire because they generate hydrogen gas.**

## CAUTION

If using a serviceable battery, never over fill the battery with water above the upper limit.

## WARNING

Always disconnect a battery charger from its AC source before disconnecting the battery cables. Failure to do so can result in voltage spikes high enough to damage the genset DC control circuits and charger.

## WARNING

Make certain the battery is well-ventilated before servicing. Arcing can ignite explosive hydrogen gas given off by batteries, causing severe personal injury. Arcing can occur when the cable is removed or reattached, or when negative (-) battery cable is connected and a tool used to connect or disconnect positive (+) battery cable touches the frame or other grounded metal that is part of the set. Always remove negative (-) cable first, and reconnect it last. Make certain hydrogen gas from the battery, engine fuel, and other explosive fumes are fully dissipated. This is especially important if the battery has been connected to a battery charger.

# IMPORTANT SAFETY INSTRUCTIONS

## FIRE PROTECTION

The design, selection, and installation of fire protection systems is beyond the scope of this manual because of the wide range of factors to consider. In general, every possible measure should be taken to prevent fire hazards and to protect property and people. Consider the following:

- A protection system must comply with the requirements of the authority having jurisdiction. This could include the building inspector, fire marshal, or insurance carrier.
- In general, the generator room will be required to have a one hour fire resistance rating. If the generator set will be in a Level 1 (life safety) application, as defined by NFPA 110, generator room construction will have a two hour resistance rating.
- The generator room should not be used for storage purposes.
- Generator rooms should be classified as hazardous locations (as defined by the NEC) solely by reason of the engine fuel.
- The authority having jurisdiction will usually classify the engine as a low heat appliance when use is only brief, infrequent periods.
- The authority having jurisdiction may specify the quantity, type, and sizes of approved portable fire extinguishers required for the generator room.
- Install the appropriate fire extinguishers in convenient locations. Consult the local fire department for the correct type of extinguisher to use. **DO NOT use foam on electrical fires.** Use extinguishers that are rated ABC by NFPA.
- Use dry chemical, foam, or carbon dioxide (CO<sub>2</sub>) fire extinguishers on battery fires.
- A manual **EMERGENCY STOP** station outside the generator room or remote from a generator set in an outside enclosure is recommended for shutting down the generator set in the event of a fire or other type of emergency.
- The authority having jurisdiction may have more stringent restrictions on the amount of fuel that can be stored inside the building than published in national standards.
- Fuel tanks located inside buildings and above the lowest story or basement should be diked in accordance with NFPA standards.

- The genset should be exercised periodically under at least 30% load until it reaches stable operating temperatures and run under nearly full load at least once a year to prevent fuel from accumulating in the exhaust system.
- Properly store fuel, batteries, and other fire hazardous material.
- The genset should be inspected regularly for fire hazards.
- When open bottom generator is used, it is recommended the assembly be installed over noncombustible materials and located in such a manner such that it prevents a combustible materials from accumulating under the generator set.
- Installation should provide a safe easy method to clean up spilled engine fluids.
- Post **NO SMOKING** signs near generator set, battery storage, and fuel storage areas.

# IMPORTANT SAFETY INSTRUCTIONS

## Lifting the Generator Set

- Before lifting, make sure the generator's lifting devices are secure and that there is no apparent damage to the generator itself (loose screws, nuts and bolts). If any part is loose or damaged, please take corrective action before lifting.
- Always drain fuel prior to lifting.
- Always make sure crane or lifting device has been properly secured to the hook of guard frame on generator.
- **NEVER** lift the machine while the engine is running.
- Use adequate lifting cable (wire or rope) of sufficient strength.
- When lifting the generator, always use the balanced center-point suspension hook and lift straight upwards.
- **NEVER** allow any person or animal to stand underneath the machine while lifting. Make sure the lifting path of the generator set is clear before moving.
- When loading the generator on a truck, be sure to use the front and back frame bars as a means to secure the generator during transport.
- Do not lift the generator set by the lifting eyes attached to the engine and/or alternator. These lifting eyes are only used during generator assembly and are not capable of supporting the entire weight of the genset.
- A four-point lifting method is necessary to lift the genset. To maintain generator balance during lifting, the lifting apparatus must utilize the four skid lifting holes. One method of lifting the genset uses an apparatus of hooks and cables joined at a single rigging point. The use of spreader bars is necessary with this method to avoid damage to the set during the lifting procedure. The spreader bars should be slightly wider than the genset skid so the set is not damaged by lifting cables and only vertical force is applied to the skid while lifting. The genset may also be lifted by placing bars through the skid lifting holes and attaching hooks to the end of the bars. Be sure all lifting equipment is properly sized for the weight of the genset.

## Transporting

- Always shutdown engine before transporting.
- Never transport generator with air intake doors open.
- Tighten fuel tank cap securely.
- Drain fuel when transporting generator over long distances or bad roads.
- Always tie-down the generator during transportation by securing the generator.
- If generator is mounted on a trailer, make sure trailer complies with all local and state safety transportation laws. See the operation manual for towing procedures.
- The transporting vehicle/trailer must be sized for the dimension and weight of the genset. Consult the set dimensional drawing or contact the factory for information (weight, dimensions) pertinent to planning transport. The overall height of a generator set in transit (including vehicle/trailer) must not exceed 13.5 ft (4.1 m) unless special hauling permits are obtained (check Federal, State, and local laws prior to transporting). Larger units (above 1000 kW) should be transported on low-boy-type trailers with a deck height of 25 in. (635 mm) or less to meet clearance requirements. Large (unboxed) generators with radiators should be loaded with the radiator facing the rear to reduce wind resistance while in transit. Radiators with free-wheel fans must have the fan secured to prevent rotation that might introduce flying objects to the radiator core or fan blades.
- Even the heaviest of units is capable of movement during shipment unless properly secured. Fasten the set to the vehicle/trailer bed with properly sized chain routed through the mounting holes of the skid. Use chain tighteners to remove slack from the mounting chain. Cover the entire unit with a heavy-duty tarpaulin and secure tarpaulin to the genset or trailer as circumstances dictate.

## Introduction

Engine-Generator sets provide emergency power in the event of utility power failure, provide power where utility power is not available and can provide an alternative power means in areas where utility power may be more expensive.

Part of the reason for the growing emphasis on emergency/standby power systems is the proliferation of electronic computers in data processing, process control and life support systems, and any other system that requires a continuous, uninterrupted flow of electrical energy. Generator sets must be applied in such a way as to provide reliable, electrical power of the *quality* and *capacity* required.

## About This Manual

This manual provides specific recommendations for installation of MQ Power's Industrial generator sets (gensets). This manual will contain the following information:

1. **Application** — This section provides information on sizing the correct generator set, determining load characteristics, and environmental considerations.
2. **Mounting Recommendations** — This section provides mounting recommendations such as typical fastening, footing, foundations, proper space requirements, and vibration isolation.
3. **Mechanical Connections** — This section provides typical information regarding the fuel system, battery system, exhaust system, proper ventilation, and proper cooling.
4. **Ventilation and Cooling** — This section shows different installation methods for ventilating and cooling the genset.
5. **Electrical Connections** — This section provides the location of electrical connection points for DC Controls, AC electrical connections, and system & equipment grounding.
6. **Pre-Start Preparation** — Checklist of items or procedures needed to prepare the generator set for operation.

## Safety Considerations

The Multiquip power genset have been carefully designed to provide safe and efficient service when properly installed, maintained, and operated. However, the overall safety and reliability of the complete system is dependent on many factors outside the control of the generator set manufacturer. This manual is provided to illustrate recommended electrical and mechanical guidelines for a safe and efficient installation.

All systems external to the generator (fuel, exhaust, electrical, etc.) must comply with all applicable codes. Make certain all required inspections and test have been completed and all code requirements have been satisfied before certifying the installation is complete and ready for service.

Always remember: **SAFETY FIRST!!!** Safety involves two aspects: safe operation of the generator set itself (and its accessories) and reliable operation of the system. Reliable operation of the system is related to safety because equipment affecting life and health, such as life-support equipment in hospitals, emergency lighting, building ventilators, elevators, and fire pumps may depend upon the generator set.

In North America, many safety (and environmental) issues related to generator set applications are addressed by the following standards of the National Fire Protection Association (NFPA):

- Flammable and Combustible Liquids Code — NFPA 30
- National Fuel Gas Code — NFPA 54
- National Electrical Code — NFPA 70
- Health Care Facilities Code — NFPA 99
- Life Safety Code — NFPA 101
- Emergency and Standby Power Systems — NFPA 110

Many national, state, and local codes incorporate the above standards (and others) by reference. Each of these standards and the codes that reference them are periodically updated, requiring continual review. Compliance with all applicable codes is the responsibility of the facility design engineer. For example, some areas may have certificate-of-need, zoning permit, building permit, or other site specific requirements. Be sure to check with all local governmental authorities before designing the generator set installation.

## Overview

These installation recommendations apply to typical installations with standard model gensets. Whenever possible, these recommendations also cover factory designed options or modifications. However, because of the large amount of variables involved with any installation, it is not possible to provide specific recommendations for every possible situation.

This manual *does not* provide complete application information for selecting a genset or designing the complete installation. *This manual is a reference tool only.* If there are any questions not answered by this manual, contact your nearest MQ Power dealer or distributor for assistance.

## Application and Installation

A standby power system must be carefully planned and correctly installed for proper operation. This involves two essential elements of application and installation.

### Application

Application, as it applies to genset installations refers to the design of the complete standby power system that usually includes power distribution equipment, transfer switches, ventilation equipment, and mounting pads. This also includes cooling, exhaust, and fuel systems.

Each system must be correctly designed so the complete system will function as intended. Application and design is an engineering function generally done by specifying engineers or other trained specialists. Specifying consulting engineers are responsible for the design of the complete standby system and for selecting the materials and products to be used.

### Installation

Installation refers to the actual setup and assembly of the standby power system. The installers, usually

## Selection and Application

Generator set size and site location should be considered in the preliminary design and budget estimate. The generator size should be selected according to the required load. Choosing a mounting site located inside the building or outside in a shelter or housing will help determine how the genset will be installed and what specific issues need to be addressed.

## Sizing

It is important to assemble a reasonably accurate load schedule as soon as possible for budgeting project costs. If all the load equipment information needed for sizing is not available early in the design planning, estimates and assumptions will have to be made in order to account for all needed power during a preliminary calculation. When all the information becomes available, it is important to recalculate the sizing requirements to ensure reliable operation.

Large motor loads, uninterrupted power supplies (UPS), variable frequency drives, and medical diagnostic imaging equipment have a considerable effect on the generator set sizing and should be considered closely. The required power to start a motor can be considerably larger than the power required to maintain the load.

## Fuel Requirements

Diesel engine generator sets are recommended for emergency/standby applications. Premium No. 2-D Grade diesel fuel is recommended for performance and engine life.

On-site fuel storage must be provided. The storage life for diesel fuel is up to two years when stored properly. Proper supply tank sizing should allow fuel turnover based on scheduled exercise and test periods. Do not provide a fuel tank that is too large to avoid condensation mixing with the fuel. A microbicide may be required if fuel turnover is low or conditions promote the growth of microbes in the fuel.

Always consider emissions requirements when designing the fuel and exhaust system. Refer to the Fuel System section for more information.

## Cold Climates and Derating Factors

Extreme temperature and high elevation effect the efficiency of the engine-generator set. Always take into account derating factors of climate and elevation when sizing a generator set.

Use Premium No.1-D Grade diesel fuel when the ambient temperature is below freezing. Fuel heating may be required to prevent fuel filters from clogging when temperatures fall below the cloud point of the fuel at approximately 20°F (-6°C) for No. 2-D and -15°F (-26°C) for No. 1-D.

## Location

Location of the generator set will determine the cost effectiveness of an installation. The generator set can be located inside a building or outside the building with a shelter or weather-protective housing. The location will help determine the layout of the fuel tanks, louvers, ventilation ducts, accessories, etc.

## Indoor and Outdoor Locations

Consider the following when deciding where to locate the generator set:

- Safety considerations
- Noise. See page 26-30 for environmental considerations.
- Ambient temperature
- Mounting
- Fuel, exhaust, ventilation, and cooling systems
- Location of the distribution switchboard and transfer switch
- Branch circuits for coolant heaters, battery charger, etc.
- Security from flooding, fire, icing, and vandalism
- Containment of accidentally spilled or leaked fuel or engine fluids

## Outdoor Locations

- Airborne noise
- Type of housing. Weather and silenced acoustic housings available
- Security Fences and sight barriers
- Property Line Distances
- Engine exhaust. Engine exhaust must be routed away from vents and building openings.

## Indoor Locations

- Dedication of room for the generator sets only. For emergency power systems, codes may require the generator room be dedicated for that purpose only. Also consider the effect of the large ventilation air flows would have on other equipment in the same room.
- Fire rating of the room construction. Most codes specify a 1 or 2 hour rating. Check with the local fire authority for code guidelines.
- Working space. Working space around electrical equipment is usually specified by code. There should be at least four feet (1200 mm) of clearance around each generator set. The generator should be accessible for service without removing the set or any accessories.
- Type of cooling system. A factory-mounted radiator is recommended. Whenever possible.
- Ventilation. Large volumes of air flow are involved. Room ventilation fans might be required for heat exchanger or remote radiator configurations.
- Engine exhaust. The engine exhaust outlet should be as high as practical on the downwind side of the building and away from vents and building openings.
- Fuel storage and piping. Codes may restrict fuel storage inside buildings. It is important to consider a safe method for refueling the fuel tank. Check with the local fire authority for code guidelines.

## Generator Set Sizing Calculations

The generator set must be sized to supply the maximum starting (power surge) demands and the steady-state running loads of the connected equipment.

It is important to have the correct generator to meet the demands of the starting kVA (SkVA), starting kW (SkW), running kVA (RkVA) and running kW (RkW). A value for generator kW (GkW) is also obtained when nonlinear loads are included in the sizing calculation.

Once the starting and running loads have been determined, it is typical to add a margin factor of up to 25% for future expansion or to select a generator set of the next largest standard rating. A large connected load that does not run during usual power outages, such as a fire pump, can serve as part of a margin factor. For a fuel efficiency standpoint, the running load should stay within approximately 50 to 80% of the generator kW rating. To avoid "wet stacking" the running load should not be less than 30 percent of the generator set rating.

It may be necessary to oversize a generator set in applications where the voltage and frequency dip performance specifications are more stringent than usual, particularly when large motors are started across-the-line or UPS equipment is involved. Applications that involve any of the following nonlinear loads may also make it necessary to oversize the generator set or the generator:

- Static Uninterrupted Power Supplies (UPS)
- Battery Charging Rectifiers (Telecommunications)
- Variable Frequency Drives (VFD)
- Medical Diagnostic Imaging Equipment

The use of closed-transition autotransformer starters for reduced voltage starting of large motor loads will reduce the size of the generator set required relative to across-the-line starting. Resistor-type reduced-voltage motor starting may actually increase the size of the generator set required due to high starting power factors. Wound rotor motors are the easiest type of motor for a generator set to start.

The first step is to create a reasonably accurate schedule of connected loads as early in the preliminary design as possible. A sample load schedule sheet can be found below on Table 1.

## Genset Sizing Procedure

When calculating the generator size needed for the application, consider the following procedure:

- Step 1. Prepare a load schedule
- Step 2. Enter loads in step sequence on the worksheet
- Step 3. Enter individual load characteristics on the worksheet
- Step 4. Find the load step totals
- Step 5. Select a generator set

### Step 1. Prepare a Load Schedule

All the loads that will be connected to the generator set should be recorded on the load schedule. Identify each load as to type, power rating, and quantity. See Table 1 below for the loads listed (in *italics*) for an example calculation.

Table 1. Load Schedule				
Load#	Load Description	Type of Load	Power Rating	Load QTY.
		Examples: Lighting.....kW Static UPS.....kVA Variable Speed Drives.....HP Telecom DC Rectifiers.....kVA Motors.....HP		
1	<i>Water Pumps #1 &amp; #2</i>	<i>Motor, Nema Code letter G, former starter (80% Tap)</i>	<i>100 HP</i>	2
2	<i>Water Pumps #3</i>	<i>Motor, Nema Code letter G, former starter (80% Tap)</i>	<i>100 HP</i>	1
3	<i>Fluorscent Lighting</i>	<i>Lighting</i>	<i>10 HP</i>	1

## Generator Set Sizing Calculations (Continued)

### Step 2. Create a Generator Set Worksheet

- a. When creating a worksheet, number a worksheet for each sequenced load step. The number block is in the upper right hand corner of the worksheet. Worksheet #1 will coincide with Load Step #1, Worksheet #2 will coincide with Load Step #2, and etc.. The *step sequence guidelines* will provide additional information to be followed here. The worksheets need not have load step numbers unless starting is sequential.
- b. Enter the individually assigned load numbers (load schedule) onto the appropriate generator set sizing worksheet. That is, all the load numbers for load step #1 should be entered on worksheet #1, for load step #2 on worksheet #2, and etc.
- c. For each load, enter the *Load QTY* marked on the load schedule in the column labeled *QTY* on the worksheet.

Figure 1 on page 18 is an example load calculation for an application involving a two-step load starting sequence. Because the application is a two-step load starting sequence, it requires two worksheets as shown. The entries are in *italics*.

### Step Sequence Guidelines

- **Single Step, Simultaneous Starting** — One commonly used approach is to assume that all connected loads will be started simultaneously in a single step, regardless of the number of transfer switches used. This approach assures that the genset is properly sized to meet the entire load demand and is the most conservative method.
- **Single Step, with Diversity Factor** — This is similar to simultaneous starting in a single step, except that an estimated diversity factor, of perhaps 80 percent, is applied to reduce the starting kVA (SkVA) and starting kW (SkW) totals to account for whatever automatic starting controls may be provided with the load equipment.
- **Multiple Step Sequence** — Sequenced starting of loads (where possible) will often permit the most precise load demand for selecting a generator.

A step sequenced start may be approximated, for example, by dividing the loads into blocks each served by a separate transfer switch and then using the standard time delay on transfer to stagger connection of each block onto the generator set. However, once all of the loads have been brought up on line with the genset, the load equipment may be frequently started and stopped by automatic controls. In such cases, the genset will have to be sized to start the largest motor last, with all other connected loads on line.

Consider the following when controls or delays are provided to step sequence the loads onto the generator set:

- Start the largest motor first. Use only when on a manual starting system.
- Load the UPS last. UPS equipment is typically frequency sensitive, especially to the rate of change of frequency. A pre-loaded genset will be more stable in accepting the UPS load.

Generator Set Sizing Worksheet										Load Step # 1		
Load #	Individual Load Characteristics						Load Step Totals					
	SkVA	SkW	RkVA	RkW	GkW	QTY	skVA	skW	RkVA	RkW	GkW	
	Enter RkW total from previous load step --->							—				
	Enter RkVA, RkW, and GkW totals from previous load step -->							—	—	—	—	—
1.	377.6 <sup>a</sup>	113.3 <sup>b</sup>	89 <sup>d</sup>	81.9 <sup>c</sup>	81.9 <sup>e</sup>	2	755.2 <sup>f</sup>	228 <sup>f</sup>	178 <sup>f</sup>	163.8 <sup>f</sup>	163.8 <sup>e-f</sup>	
3.	—	—	—	—	—	1	10.5 <sup>g</sup>	10 <sup>g</sup>	10.5 <sup>g</sup>	10 <sup>g</sup>	10 <sup>e</sup>	
—	—	—	—	—	—	—	—	—	—	—	—	
Load Step Totals ----->							<b>765.7</b>	<b>238</b>	<b>188.5</b>	<b>173.8</b>	<b>173.8</b>	

Generator Set Sizing Worksheet										Load Step # 2		
Load #	Individual Load Characteristics						Load Step Totals					
	SkVA	SkW	RkVA	RkW	GkW	QTY	skVA	skW	RkVA	RkW	GkW	
	Enter RkW total from previous load step --->							173.8				
	Enter RkVA, RkW, and GkW totals from previous load step -->							188.5	173.8	173.8	173.8	
2.	—	—	—	—	—	1	89 <sup>h</sup>	81.9 <sup>h</sup>	89 <sup>h</sup>	81.9 <sup>h</sup>	163.8 <sup>h</sup>	
—	—	—	—	—	—	—	—	—	—	—	—	
—	—	—	—	—	—	—	—	—	—	—	—	
Load Step Totals ----->							<b>89</b>	<b>255.7</b>	<b>277.5</b>	<b>255.7</b>	<b>337.6</b>	

**Figure 1. Genset Sizing Worksheets (Example Two-Step Loading Application)**

**NOTES:**

- a. For the two 100 HP motors, SkVA = HP x NEMA Code Letter Multiplier (Table 6) = 100 x 5.9 x 0.64 = 377.6
- b. SkW = SkVA x SPF = 377.6 x 0.3 = 113.3
- c. RkW = HP x 0.746 / 0.91 = 81.9
- d. RkVA = RkW / RPF = 81.9 / 0.92 = 89
- e. A GkW total will need to be found because Load #2 is a nonlinear load. Therefore, enter values for GkW for the linear loads. GkW= RkW for linear loads.
- f. These values are twice the values in the *individual load characteristics* columns because QTY is 2 for Load #1.
- g. For the fluorescent lighting, RkW = SkW. SPF and RPF both = 0.95
- h. For the 100 HP VFD motor: GkW = RkW x generator sizing factor = 81.9 x 2.0 = 163.8; SkW = RkW; and SkVA = RkVA.

## Generator Set Sizing Calculations (Continued)

### Step 3. Enter Individual Load Characteristics

- a. Calculate the values for SkVA, SkW, RkVA, and RkW and then enter the values on the worksheets. See *determining load characteristics* on page 20 for instructions on how to calculate the values for various types of loads.
- b. If the load quantity (QTY) is one, enter the values for SkVA, SkW, RkVA, and RkW directly onto the columns under the *load step totals* heading.
- c. If the load quantity is greater than one, enter the values for SkVA, SkW, RkVA, and RkW in the columns under the *individual load characteristics* heading. Then multiply each load entry by the number under QTY and enter the products under the *load step totals* heading for SkVA, SkW, RkVA, and RkW.
- d. If nonlinear loads are included, calculate a GkW value for each nonlinear load and enter it under the GkW column. Follow the guidelines in part C above for multiple nonlinear loads.
- e. In order to obtain a total GkW in applications that include linear as well as nonlinear loads, enter the values for RkW for all the linear loads under GkW as well ( $RkW = GkW$  for linear loads only).

### Step 4. Enter Individual Load Characteristics

Now all the loads on the *load schedule* should be listed on the *generator set sizing worksheets*, all the load characteristics should be calculated and entered on the worksheets, and the worksheets numbered in load step sequence.

Referring back to Figure 1, find the load step totals as follows:

- a. Starting with worksheet #1 (Load Step #1), add the entries in each column under the *load step totals* heading and enter the sums on the *load step totals* line.
- b. On worksheet #2 enter the *load step totals* from worksheet #1 as instructed on the worksheet.
- c. Repeat steps a and b as necessary through all the worksheets.
- d. Go back through all the worksheets and highlight or circle the highest load step total of SkVA, SkW, RkVA, RkW, and GkW. Generator set selection will be based on these values.

## Generator Set Sizing Calculations (Continued)

### Step 5. Select a Generator Set

#### a. Establish the minimum size required

- i. At this point the addition of future loads should be considered. The RkW and RkVA values that were highlighted or circled in Step 4 (previous page) should be multiplied by a factor representing your best judgement.
- ii. Referring to the genset specification sheets, pick the generator set model having a kW/kVA rating that meets the highest RkW and RkVA totals highlighted or circled in Step 4. Use the values calculated for RkW and RkVA in sub-step i above if the future addition of load was factored in.
- iii. In addition to the specification sheet, the motor starting curve should be referenced. Make sure to take into account any derating factors such as high altitudes or ambient temperature.

#### b. In applications where it is necessary to limit transient voltage dip to approximately 10 to 20 percent of nominal voltage, multiply the SkVA highlighted or circled in Step 4 by at least 1.25. Repeat the selection steps above.

*A transient voltage dip of approximately 20 to 40% can be expected when the genset selected is only slightly greater than the maximum SkVA. The actual transient voltage dip is a function of several factors and is difficult to determine accurately.*

- c. In applications where GkW has been determined (Step 4) and where GkW is greater than the kW rating of the generator set that has been selected, an alternator (AC generator) must be picked for the set which has a kW rating equal to or greater than GkW.
  - i. See the alternator data sheet for the alternator temperature rise. Compare GkW to the alternator kW rating at the appropriate voltage. The greater the voltage, the greater the kW rating.
  - ii. If GkW is too high for the alternator selected to meet the temperature rise specifications (if any), find the alternator data sheet for the alternator specified for the next lower temperature rise. Compare GkW to the alternator kW rating at the appropriate voltage. Repeat the procedure with the any other models. If there are no generator temperature rise specifications that have to be met, consider comparing GkW to the kW rating at the higher temperature rise rating of 125°C.
  - iii. If none of the alternators available for the generator set has a kW rating sufficient to meet GkW, refer to the specification sheet for the next larger size generator set and repeat the selection process.

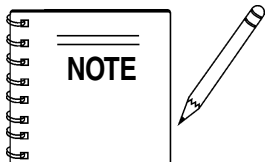

The running load should not be less than 30 percent of the generator set rating.

# GENSET SIZING — DETERMINING LOAD CHARACTERISTICS

## Determining Load Characteristics

### Lighting

For all types of lighting loads:

RkW = The sum of the rated watts of all lamps and ballasts.

Typical ballast wattages are defined by Table 2:

LAMP	BALLAST
48 inch T-12, 40 W, Preheat	10 W
48 inch T-12, 40 W, Rapid Start	14 W
High Output 40 W Fluorescent	25 W
Mercury, 100 W	18-35 W
Mercury, 400 W	25-65 W

For all types of lighting loads, except for high intensity discharge (HID), use the following:

$$SkW = RkW$$

Due to the starting characteristics of HID lighting, assume that

$$SkW = 0.75 \times RkW$$

Unless otherwise known, assume the following starting and running power factors (SPF and RPF, respectively, see Table 3 below) for the following types of lighting:

Type of Lighting	SPF	RPF
Fluorescent	0.95	0.95
Incandescent	1.00	1.00
High Intensity Discharge	0.85	0.90

Then the following can be calculated:

$$RkVA = \frac{RkW}{RPF}$$

$$SkVA = \frac{SkW}{SPF}$$

### Single-Phase Induction Motor

For 1Ø motors, use the SkVA, SkW, RkVA, and RkW values in Table 4 below that correspond to the motor nameplate horsepower and type.

HP	RkW	RkVA	SkVA	SkW
Split Phase				
1/6	0.3	0.5	3.5	2.8
1/4	0.4	0.6	4.8	3.8
1/3	0.5	0.7	5.6	4.5
1/2	0.7	0.9	7.7	6.1
Capacitor Start / Induction Run				
1/6	0.3	0.5	2.6	2.0
1/4	0.4	0.6	3.3	2.6
1/3	0.5	0.7	3.9	3.1
1/2	0.7	0.9	5.3	4.25
3/4	1.0	1.25	7.1	5.7
1	1.2	1.6	9.5	7.6
1-1/2	1.6	2.0	14.25	11.4
2	2.2	2.7	19	15.2
3	3.3	4.1	28.5	22.8
Capacitor Start / Capacitor Run				
1/6	0.3	0.5	2.8	2.3
1/4	0.4	0.6	3.8	3.0
1/3	0.5	0.7	3.6	2.9
1/2	0.7	0.9	5.9	4.7
3/4	1.0	1.25	8.0	6.4
1	1.2	1.6	10.6	12.7
1-1/2	1.6	2.0	16.0	12.7
2	2.2	2.7	21.2	17.0
3	3.3	4.1	31.8	25.5
Permanent Split Capacitor (PSC)				
1/6	0.3	0.5	1.0	0.8
1/4	0.4	0.6	1.5	1.2
1/3	0.5	0.7	2.0	1.6
1/2	0.7	0.9	3.0	2.4

# GENSET SIZING — DETERMINING LOAD CHARACTERISTICS

## Three-Phase Induction Motors

Calculate RkW as follows:

$$RkW = \frac{\text{Nameplate HP} \times 0.746}{\text{EFF}}$$

If EFF (motor running efficiency) of the motor is not known, refer to Table 5 and use the value corresponding to the motor horsepower.

Calculate RkVA as follows:

$$RkVA = \frac{RkW}{\text{RPF}}$$

If RPF (running power factor) is unknown, refer to Table 5 and use the value corresponding to the motor horsepower.

Calculate SkVA as follows:

1. If the NEMA motor code letter is unknown, refer to Table 4 and select the SkVA value corresponding to the code letter and the horsepower. The factors used to generate these values are shown in Table 5.
2. If the NEMA motor code letter is unknown, refer to Table 7 and select the SkVA value in bold letters that corresponds to the motor horsepower. The bold letters show the values for the NEMA code letters that are typical for standard motors.
3. If the motor is rated greater than 500 HP and the NEMA motor code is known, calculate SkVA as follows:

$$skVA = \text{Nameplate HP} \times \text{NEMA Code Letter Multiplying Factor}$$

4. If the motor is rated more than 500 HP and the NEMA motor code is not known, assume a NEMA code letter of G and calculate SkVA as follows:

$$skVA = \text{Nameplate HP} \times 5.9$$

where 5.9 is the multiplying factor corresponding to NEMA code letter G in Table 5.

## NEMA Code Letter Multiplying Factor

Use Table 5 below to calculate the starting kVA. DO NOT confuse the NEMA (National Electrical Manufacturers Association) *motor code* and *design letters*.

The code letter refers to the ratio of locked rotor kVA to HP, whereas the design letter has to do with the ratio of torque to speed.

Table 5. NEMA Code Letter Multiplying Factor

A	2.0
B	3.3
C	3.8
D	4.2
E	4.7
F	5.3
G	5.9
H	6.7
J	7.5
K	8.5
L	9.5
M	10.6
N	11.8
P	13.2
R	15.0
S	16.0
T	19.0
U	21.2
V	23.0

# GENSET SIZING — DETERMINING LOAD CHARACTERISTICS

## Determining Load Characteristics (continued)

5. If reduced voltage motor starting is used, determine SkVA as in Steps 1, 2, 3, or 4 on previous page, and then multiply the value by the appropriate multiplying factor in Table 5. Thus the following formula:

$$\mathbf{SkVA} = \text{skVA} \times \text{skVA multiplying factor}$$

Calculate SkW as follows:

$$\mathbf{skW} = \text{skVA} \times \text{SPF}$$

1. If SPF (Starting Power Factor) is unknown, refer to Table 4 and use the value corresponding to the motor horsepower. *If a resistor-type reduced voltage motor starting is used, use the value for SPF in Table 6 below.*
2. Multiply SkW by 0.5 for motors with low inertia loads (i.e., centrifugal fans, compressors and pumps) where starting torque requirements are low.

Table 6. Reduced Voltage Starting Methods and Characteristics

Starting Method	% Full Voltage Applied	% Full Voltage kVA	% Full Voltage Torque	SkVA Multiplying Factor	SPF
Full Voltage	100	100	100	1.0	—
Reduced Voltage Autotransformer	80	64	64	0.64	—
	65	42	42	0.42	—
	50	25	25	0.25	—
Series Reactor	80	80	64	0.80	—
	65	65	42	0.65	—
	50	50	25	0.50	—
Series Resistor	80	80	64	0.80	0.60
	65	65	42	0.65	0.70
	50	50	25	0.50	0.80
Star Delta	100	33	33	0.33	—
Part Winding (Typical)	100	60	48	0.6	—
Wound Rotor Motor	100	160*	100*	1.6*	—

\*— These are percents or factors of running current, which depend on the value of the series resistances added to the rotor windings.

# GENSET SIZING — DETERMINING LOAD CHARACTERISTICS

## Three Phase NEMA Motor Code Table

Table 7 lists the 3Ø motor starting kVA, starting power factor, and motor factors. Do not confuse the NEMA (National Electrical Manufacturers Association) motor Code and design letters. The code letter refers to the ratio of locked rotor kVA to HP, whereas the design letter refers to the ratio of torque to speed.

Table 7. Three Phase Motor SkVA, SPF, EFF, and RPF

HP	NEMA Motor Code Letters												Motor Factors		
	A	B	C	D	E	F	G	H	J	K	L	N	SPF	EFF	RPF
1/4	0.5	0.8	0.9	1.0	1.2	1.3	1.5	1.7	1.9	2.1	2.4	<b>2.9</b>	0.82	62.8	0.55
1/2	1.0	1.7	1.9	2.1	2.4	2.6	3.0	3.3	3.8	4.2	4.7	<b>5.9</b>	0.82	62.8	0.55
3/4	1.5	2.5	2.8	3.2	3.6	4.0	4.5	5.0	5.7	6.4	7.1	<b>8.9</b>	0.78	69.3	0.64
1	2	3	4	4	5	5	6	7	8	8	9	<b>12</b>	0.76	73.0	0.70
1-1/2	3	5	6	6	7	8	9	10	11	13	<b>14</b>	18	0.72	76.9	0.76
2	4	7	8	8	9	11	12	13	15	17	<b>19</b>	24	0.70	79.1	0.79
3	6	10	11	13	14	16	18	20	23	<b>25</b>	28	35	0.66	82.5	0.82
5	10	15	19	21	24	26	30	33	<b>38</b>	42	47	59	0.61	83.8	0.85
7-1/2	15	25	28	32	36	40	45	<b>50</b>	57	64	71	89	0.56	85.1	0.87
10	20	33	38	42	47	53	59	<b>67</b>	75	85	95	118	0.53	85.9	0.87
15	30	50	57	64	71	79	<b>89</b>	100	113	127	142	177	0.49	86.9	0.88
20	40	67	75	85	95	106	<b>119</b>	134	151	170	190	236	0.46	87.6	0.89
25	50	84	94	106	119	132	<b>149</b>	167	189	212	237	295	0.44	88.0	0.89
30	60	100	113	127	142	159	<b>178</b>	201	226	255	285	354	0.42	88.4	0.89
40	80	134	151	170	190	212	<b>238</b>	268	302	340	380	475	0.39	88.9	0.90
50	100	167	189	212	237	265	<b>297</b>	335	377	425	475	590	0.36	89.6	0.90
60	120	201	226	255	285	318	<b>357</b>	402	453	510	570	708	0.36	89.6	0.90
75	150	251	283	318	356	397	<b>446</b>	502	566	637	712	885	0.34	90.0	0.90
100	200	335	377	425	475	530	<b>595</b>	670	755	849	949	1180	0.31	90.5	0.91
125	250	418	471	531	593	662	<b>743</b>	837	943	1062	1187	1475	0.29	90.9	0.91
150	300	502	566	637	712	794	<b>892</b>	1004	1132	1274	1424	1770	0.28	91.2	0.91
200	400	669	754	849	949	1059	<b>1189</b>	1339	1509	1699	1899	2360	0.25	91.7	0.91
250	500	836	943	1061	1186	1324	<b>1486</b>	1674	1886	2124	2374	2950	0.24	92.0	0.91
300	600	1004	1131	1274	1424	1589	<b>1784</b>	2009	2264	2549	2849	3540	0.22	92.3	0.92
350	700	1171	1320	1486	1661	1853	<b>2081</b>	2343	2641	2973	3323	4130	0.19	93.1	0.92
400	800	1338	1508	1698	1898	2118	<b>2378</b>	2678	3018	3398	3798	4720	0.19	93.1	0.92
500	1000	1673	1885	2123	2373	2648	<b>2973</b>	3348	3773	4248	4748	5900	0.17	93.8	0.92

# GENSET SIZING — DETERMINING LOAD CHARACTERISTICS

## Synchronous Motors

Although starting requirements for synchronous motors are lower, it is recommended to determine starting requirements in the same manner as induction motors previously covered.

## Variable Frequency Drives

Variable Frequency Drives are nonlinear loads for which a calculation of GkW is made, in addition to RkW, RkVA, SkW, and SkVA.

Calculate RkW as follows:

$$RkW = \frac{\text{Drive Output HP} \times 0.746}{EFF}$$

Assume 0.9 for EFF (drive running efficiency) unless otherwise known.

Calculate RkVA as follows:

$$RkVA = \frac{RkW}{RPF}$$

Assume 0.9 for RPF (running power factor) unless otherwise known.

Since these drives are all current limiting:

$$SkW = RkW$$

$$SkVA = RkVA$$

Calculate GkW using the following formula, assuming a generator *sizing factor of 2* unless otherwise known.

$$GkW = 2.0 \times RkW$$

When sizing for a pulse width modulated (PWM) drive, consult the drive manufacturer to verify that the drive limits harmonic current is less than 10 percent THD on a high impedance source (e.g. a generator set), assume a sizing factor of 1.4.

Using these factors for GkW results in selecting a generator reactance low enough to limit voltage distortion caused by nonlinear loads to approximately 10 to 15%.

## Static UPS

Uninterrupted power supplies are nonlinear loads for which a calculation of GkW will be made, in addition to RkW, RkVA, SkW, and SkVA.

Calculate RkW as follows:

$$RkW = \frac{(\text{Output kVA} + \text{Battery Charging kVA}) \times RPF}{EFF}$$

In the equation above:

1. Output kVA is the nameplate kVA capacity of the UPS
2. Battery charging kVA is that required for battery charging, and can range from zero to fifty (0-50%) percent of the UPS kVA rating.
3. If the RPF (Running Power Factor) for the UPS is unknown, assume 0.9 RPF.
4. If the EFF (Running Efficiency) for the UPS is unknown, assume 0.85 EFF.

Unless otherwise known:

$$SkW = RkW$$

$$SPF = RPF$$

$$RkW = \frac{RkW}{RPF}$$

$$SkVA = \frac{SkW}{SPF}$$

Calculate GkW as follows:

For 3 Pulse UPS:

$$GkW = 2.50 \times RkW$$

For 6 Pulse UPS:

$$GkW = 1.40 \times RkW$$

For 12 Pulse UPS:

$$GkW = 1.15 \times RkW$$

## Telecom DC Rectifiers and Battery Charging Equipment

Telecom DC Rectifiers and battery charging equipment are nonlinear loads and similar to static UPS and should be sized using the same method.

# ENVIRONMENTAL CONSIDERATIONS — dB(A)

## Noise Consideration

Because noise effects the surrounding environment, it is important to consider noise factors when installing a genset. The following is a brief approach to evaluating noise sources and noise level reduction.

Noise requires a source, a path, and a receiver. In a standby system, the genset is the source, the path is air or air and a structure which transmits the noise vibrations, and the receiver is a person in the vicinity (including the operator).

Since little prevention can be done with the source or the receiver, the treatment method is manipulate the pathway of noise.

The three main components of noise from an engine-generator set are:

1. Engine exhaust (low frequency sound)
2. Engine moving parts (low and high frequency sound)
3. Radiator discharge air (high frequency sound).

## Noise Laws and Regulations

There are many state and local codes establishing maximum noise levels. Most noise regulations specify the maximum allowable noise level at the property line. Table 8 is an example of typical maximum allowable noise levels. OSHA has specific noise regulations where persons working in a generator room will be required to wear ear protection.

## Noise Level Measurement and Decibel / dB(A) Units

To measure noise properly, the subjective response of human hearing is substituted by an objective measurement of sound measured by a meter. The unit of measurement for sound is the decibel (dB). The decibel is a convenient number on a logarithmic scale expressing the ratio of two sound pressures, comparing the actual pressure to a reference pressure.

Noise regulations are written in terms of "decibels 'A' scale" or dB(A). This term means the sound pressure level has been adjusted to duplicate how the imperfect human ear hears noise. The human ear can only hear within a range of frequencies. The dB(A) weighted scale tries to simulate human loudness perception. Loudness is dependent on sound pressure level (amplitude) and frequency. See Figure 2 for a dB(A) comparison.

Decibel tests are conducted in a "free field". A free field is a sound field in which the effects of obstacles or boundaries on sound propagated in the field are negligible. A "reverberant field" is a sound field in which the effects of obstacles or boundaries on sound propagated in the field are not negligible.

Accurate noise measurements require the microphone to be placed outside the "near field". The near field is defined as the region within one wavelength or two times the largest dimension of the noise source, whichever is greater. Noise cannot be measure accurately for compliance with specifications calling for measurements within the near field.

Noise measurements should be made using a sound level meter and octave band analyzer. The microphones should be placed in a circle of 23 feet (7 meters) radius centered on the generator set.

Table 8. Typical Criteria for Outside Noise Levels

Noise Zones	Peak Day dB(A)	Peak Night dB(A)	Continuous Day dB(A)	Continuous Night dB(A)
Urban — Residential	62	52	57	47
Suburban — Residential	57	47	52	42
Very Quite Suburban or Rural Residential	52	42	47	37
Urban — Nearby Industry	67	57	62	52
Heavy Industry	72	62	67	57

# ENVIRONMENTAL CONSIDERATIONS — dB(A)

## Comparison Chart dB(A)

Figure 2 below provides a comparison of dB(A) levels for daily noises and the typical range of generator sets. Open generator sets are unboxed units where the path of noise is unobstructed. Acoustic housing enclose the genset to impede and absorb the path of noise.

For applications that require even quieter operation, see the WhisperWatt™ product line for dB(A) levels as low as 62. If quieter levels are required, please contact an MQ Power dealer.

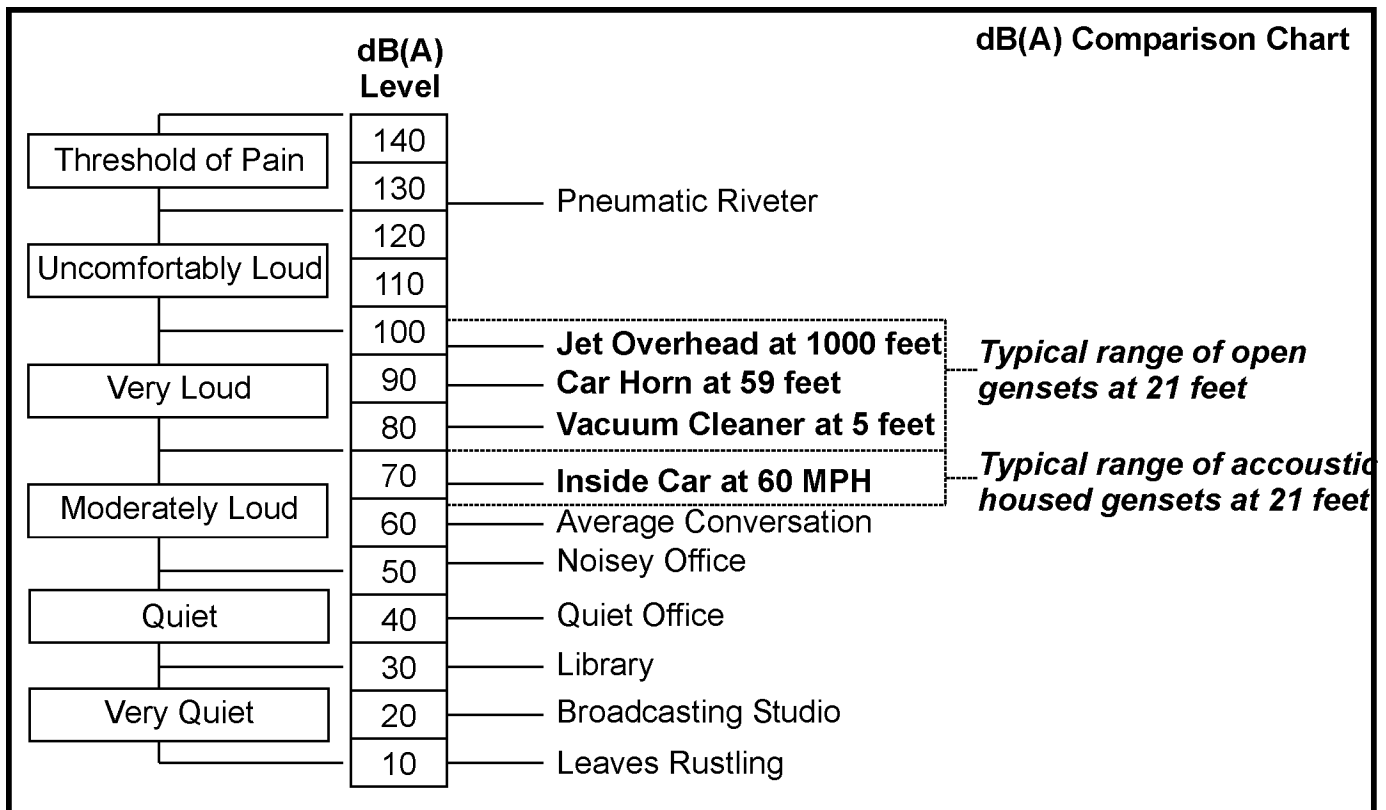

Figure 2. dB(A) Comparison Chart

# ENVIRONMENTAL CONSIDERATIONS — dB(A)

## Adding Additional Sound Sources

The noise level at a given location is the sum of the noise levels from all sources, including reflecting sources. For example, the noise level in a free field along side of two identical generator sets would be double the noise level of either set when both sets are running. A doubling of the noise level is represented as an increase of approximately 3 dB(A). In this case, if the noise level from either set is measured as 70 dB(A), the expected result of the combined generators would be 73 dB(A) when both units are running.

Figure 3 below estimates the noise level from multiple noise sources:

1. To find the difference in dB(A) between two of the sources (any pair), locate the dB(A) difference value on the horizontal scale as shown by the horizontal arrow. Add this value to the larger dB(A) value of the pair.
2. Repeat Step 1 between the value just determined and the next value. Keep repeating the process until all noise sources have been accounted for.

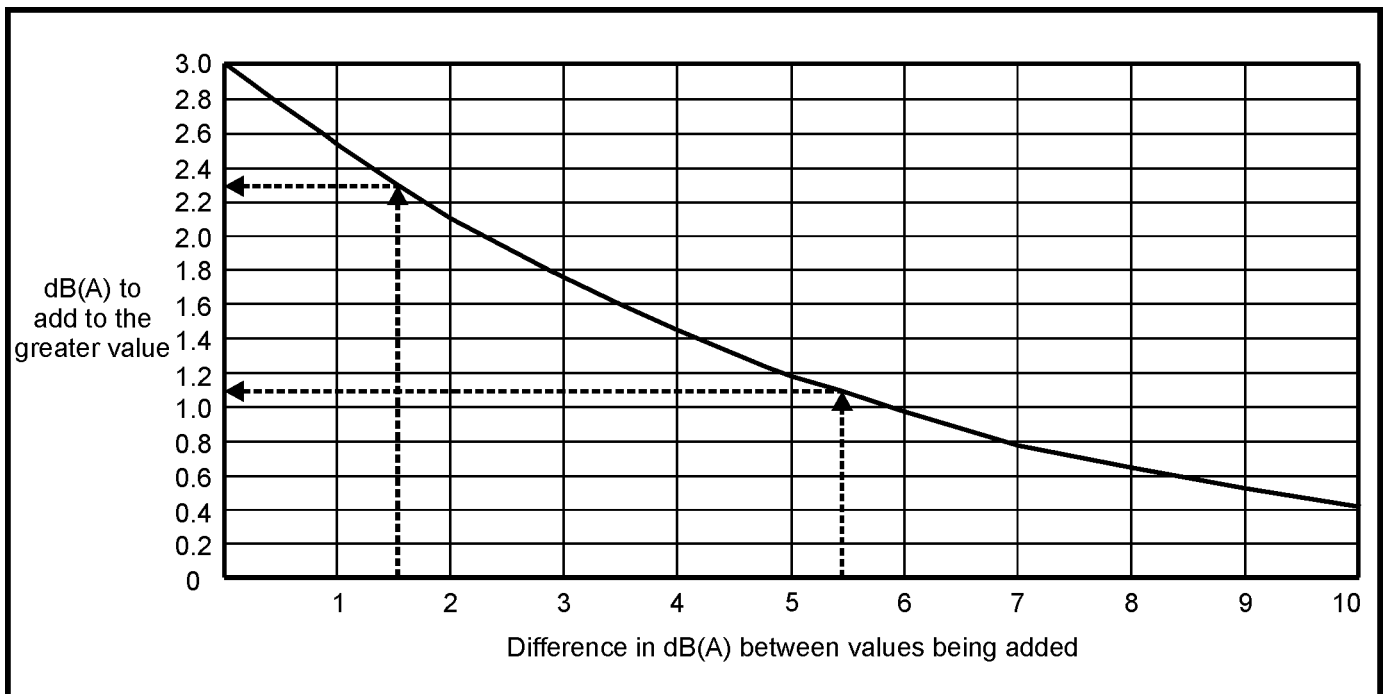

Figure 3. dB(A) Comparison Chart

Alternatively, the following formula can be used to add sound pressure levels measured in dB(A):

$$dB(A)_{total} = 10 \times \log_{10} \left( 10 \left( \frac{dB(A)_1}{10} \right) + 10 \left( \frac{dB(A)_2}{10} \right) + \dots + 10 \left( \frac{dB(A)_n}{10} \right) \right)$$

## ENVIRONMENTAL CONSIDERATIONS — dB(A)

### Effects of Distance

As the distance between a noise source and receiver increases, the sound level decreases. If a second sound measurement is taken twice as far from the source, the second reading will be approximately 6 dB(A) less than the first reading. If the sound pressure level (SPL<sub>1</sub>) of a source at distance d<sub>1</sub> is known, the sound pressure level (SPL<sub>2</sub>) at distance d<sub>2</sub> can be found as follows:

$$SPL_2 = SPL_1 - 20 \times \log_{10} \left( \frac{d_2}{d_1} \right)$$

If the sound pressure level (SPL<sub>1</sub>) at 21 meters (d<sub>1</sub>) is 100 dB(A), then at 7 meters (d<sub>2</sub>) the sound pressure level (SPL<sub>2</sub>) will thus be:

$$SPL_2 = 100 \text{ dB(A)} - 20 \times \log_{10} \left( \frac{21}{7} \right)$$

$$SPL_2 = 100 - 20 \times 0.477$$

$$SPL_2 = 90.46 \text{ dB(A)}$$

It should be noted the background noise level must be at least 10 dB(A) below the noise level of the generator set, the installation must approximate a free field environment and the generator set must be equipped with a critical grade muffler.

Figure 4 below can be used as an alternative to the formula for estimating the sound level at various distances (such as to the property line). For instance, as shown by the dashed arrows, if the noise rating of the generator set is 95 dB(A) at 7 meters, the noise level 100 meters away will be approximately 72 dB(A).

When using Figure 4, draw a line parallel to the slanted lines from the known dB(A) value on the vertical scale line to the vertical line for the specified distance. Then draw a horizontal line back to the vertical scale line and read the new dB(A) value.

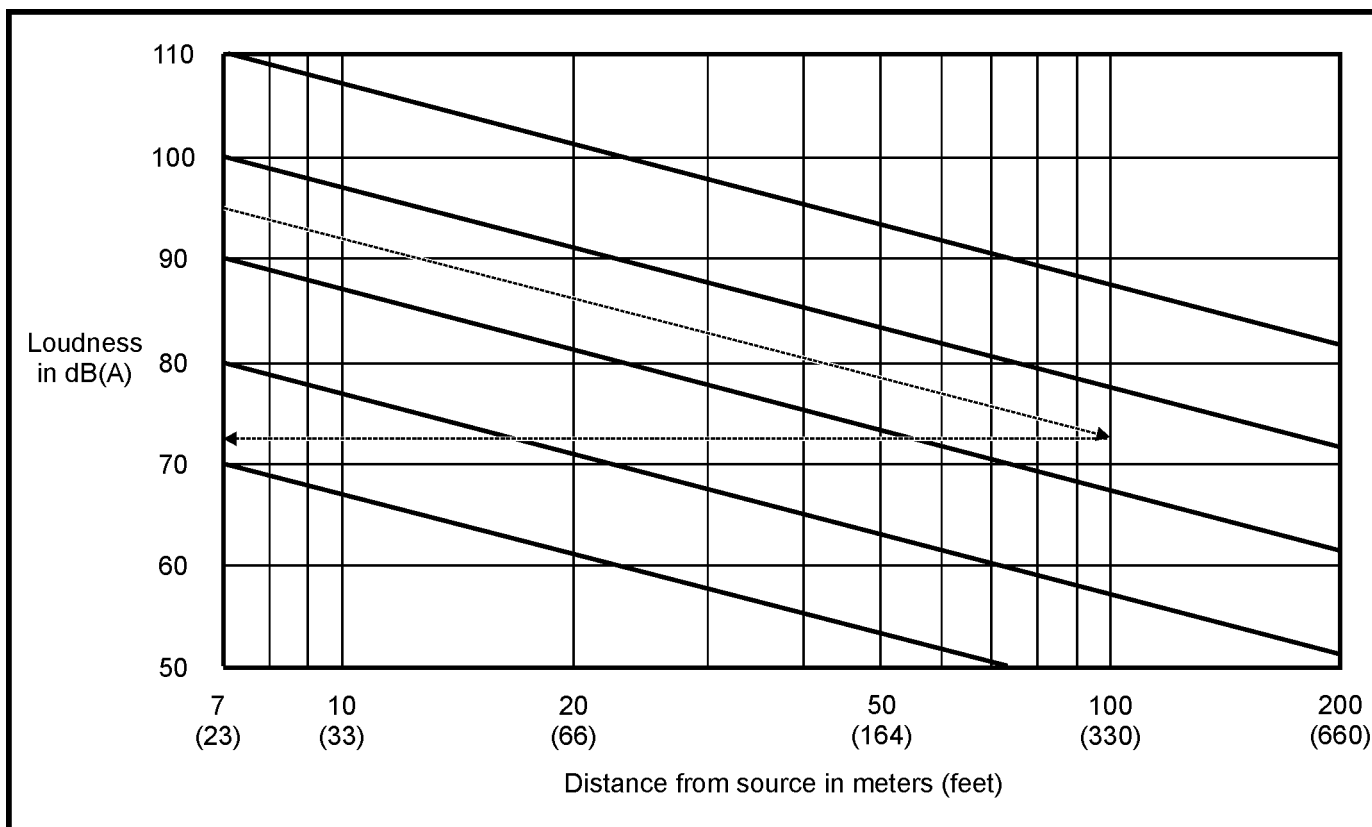

Figure 4. Distance Effects on dB(A)

# ENVIRONMENTAL CONSIDERATIONS — dB(A)

## Reducing Noise

### *Structure-Borne Noise*

Structure-borne noise is transmitted or generated as vibrations in structures. Vibrating structures create sound pressure waves (noise) in the surrounding air. Connections to a genset can cause vibrations in the building structure, creating noise. Typically, these include the skid anchors, radiator discharge air duct, exhaust piping, coolant piping, fuel lines, and wiring conduit. Also, the walls of a genset housing can vibrate and cause noise.

The following will help reduce structure-borne noise:

1. Mounting a genset on spring-type vibration isolators effectively reduces vibration transmission. See the Mounting section of this manual for details.
2. Flexible connections to exhaust pipe, fuel line, air duct, coolant pipe (remote radiator or heat exchanger systems), and wiring conduit effectively reduce vibration transmission. Flexible connections are required when the genset is mounted on vibration isolators.
3. See Figure 5 for typical measures in reducing noise.

## Reducing Noise

### *Airborne Noise*

Airborne noise is usually the most dominant type of noise. Airborne noise has a directional characteristic, particularly at the high end of the frequency range. Table 9 shows ways of minimizing airborne noise.

The following will help reduce airborne noise:

1. Redirect noise away from receivers. Vertical radiator or exhaust outlets point the noise away from people at grade level and keep them out of the path of noise.
2. Line-of-sight barriers are effective in reducing noise. A sound barrier wall will reduce noise by blocking the sound path of travel. Making noise travel through a 90 degree bend in a duct reduces high frequency noise.
3. Cover enclosure walls, ceiling, and air duct with sound absorbing (acoustic) material.
4. Remote radiators with low speed fans can be used both to reduce the level of noise at the source and to isolate it.
5. Critical grade mufflers are recommended whenever noise control is a concern. The objectionable portion of engine exhaust noise falls within the range of 125 to 1,000 hertz. Regardless of the grade of muffler selected, its effective (peak) attenuation should be within this frequency range. Typical noise attenuating ratings of mufflers are as follows:

Table 9. Noise Attenuated Muffler Ratings

Industrial Muffler	12-18 dB(A)
Residential Muffler	18-25 dB(A)
Critical Muffler	25-35 dB(A)

## ENVIRONMENTAL CONSIDERATIONS — dB(A)

### Acoustic Material

Consider the following when selecting acoustic material:

1. **DO NOT** use fiberglass as an acoustic material. Fiberglass is a poor selection of acoustic material because of its low density, poor flame retardant, and cleanability.
2. Foam is least likely to deteriorate due to abrasion and has good aesthetics. However, foam is difficult to clean and not all foams are fire retardant.
3. A concrete block enclosure is an excellent barrier in regards to noise reduction. The blocks may be filled with sand to make the wall more dense. However, concrete housing tends to become hot and superior cooling methods will be required for proper engine performance.

### Acoustic Material

Figure 5 below illustrates installation methods for reducing noise level to achieve a quieter operating generator set.

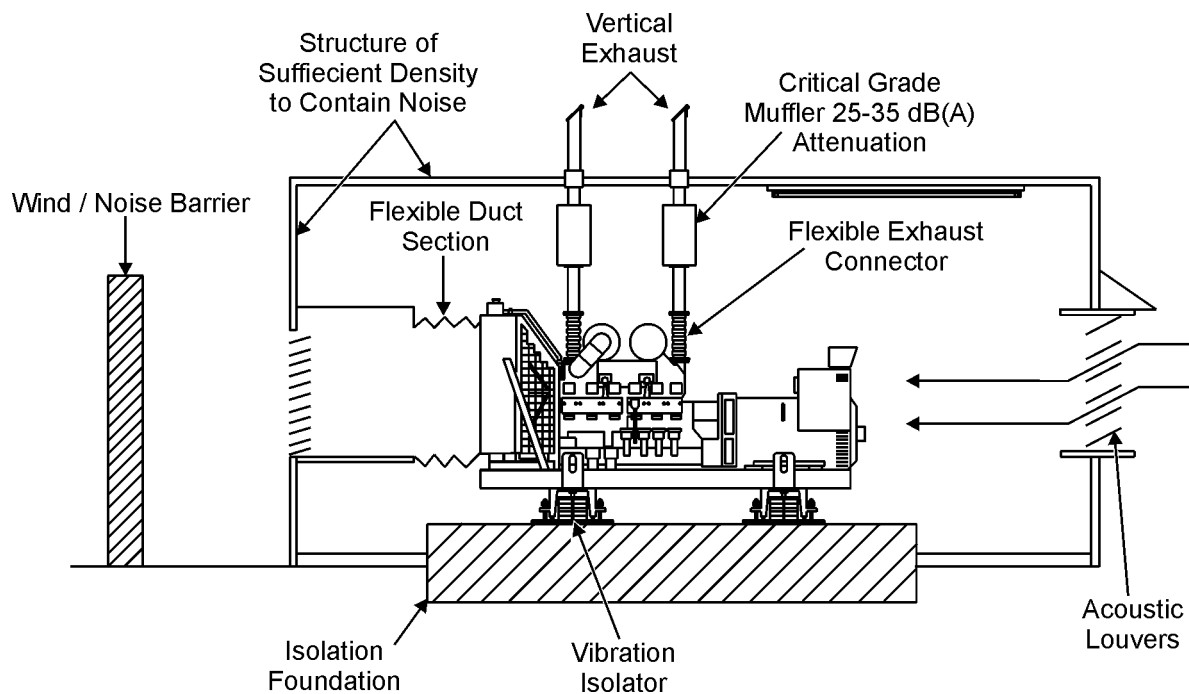

Figure 5. Reducing Noise

## Mounting

Mounting the generator set is a critical part of the installation. A proper foundation must be able to support the weight of the generator set and its accessories, resist dynamic loads, and not transmit excessive noise and vibration. Foundations can be located on the floor, roof, indoors, or outdoors.

Generator sets are typically mounted on a steel skid that provides support. Vibration isolators are recommended between the skid and the foundation to provide stable operation and avoid installation damage. Bolting the generator set directly to the floor or foundation can result in excessive noise and vibration, and possible damage to the genset and floor foundation. See *Vibration Isolators* on page 36 for details.

## Access to Set

Whenever choosing a generator site location, always allow room for service personnel and operators to gain the proper access to the unit. Always provide adequate lighting around the unit.

## Mounting on a Slab Floor

When mounting the genset on a concrete slab floor, a concrete pad should be poured on top of the floor. The concrete pad should be reinforced concrete with a 28 day compressive strength of at least 2500 psi (173 kPa), however 3000 psi is recommended. It should be at least 6 inches (150 mm) deep and extend at least 6 inches (150 mm) beyond the generator skid on all sides. Type J or L bolts may be used to anchor the skid or vibration isolators to the pad. Where allowed, drill-in anchors can be used.

## Mounting on a Sub-Base Fuel Tank

When mounting the genset on a subbase fuel cell, the vibration isolators may be installed between the genset and the fuel tank. The fuel tank must be able to support the weight of the genset and resist the dynamic loads. It is recommended that the tank be mounted with air space between the bottom of the tank and the floor underneath to reduce corrosion and permit visual inspections for leaks.

Another method is to size the isolator to support the weight of the engine-generator accessories, subbase fuel cell, and fuel. Isolators should be mounted underneath the tank.

## Mounting on a Vibration Isolating Foundation

When mounting the genset on a foundation to reduce the transmission of vibrations to the building, the weight (W) of the foundation should be at least 2 times the weight of the genset itself to resist dynamic loading. Figure 6 illustrates a typical vibration isolating foundation.

Consider the following when mounting on a vibration isolating foundation:

- The foundation should extend at least 6 inches beyond the skid on all sides. This determines the length (L) and width (w) of the foundation.
- Calculate the height (h) of the foundation necessary to obtain the required weight (W) by using the following formula:

$$\text{height of foundation} = h = \frac{W}{d \times L \times w}$$

where *d* is the density of concrete, typically 145 lbs / ft<sup>3</sup> (2322 kg/ m<sup>3</sup>)

- For convenience in general servicing such as radiator, fan belt, and oil filter maintenance, the surface of the mounting base should be at least 6 inches (152 mm) above the floor.
- The foundation must extend below the frost line to prevent heaving.
- The foundation should be reinforced concrete with a 28 day compressive strength of at least 2500 psi (173 kPa), however 3000 psi is recommended.
- The total weight (TW) of the genset, fuel, and foundation usually results in a soil bearing load (SBL) of less than 2000 lbs / ft<sup>2</sup> (96 kPa). Although this is within the load bearing capacity of most soils, always find out the allowable soil bearing load by checking the local code and the soil analysis report of the building. The soil bearing load can be calculated by using the following formula:

$$\text{Soil Bearing Load} = \text{SBL} = \frac{\text{TW}}{L \times w}$$

where "L" and "w" are the length and width of the foundation.

- Type J or L bolts should be used to anchor the skid or vibration isolators to the foundation.

## Mounting Foundation

Figure 6 below shows the typical foundation installation.

Figure 7 below shows the typical footing on a foundation in soil with a low load bearing capacity.

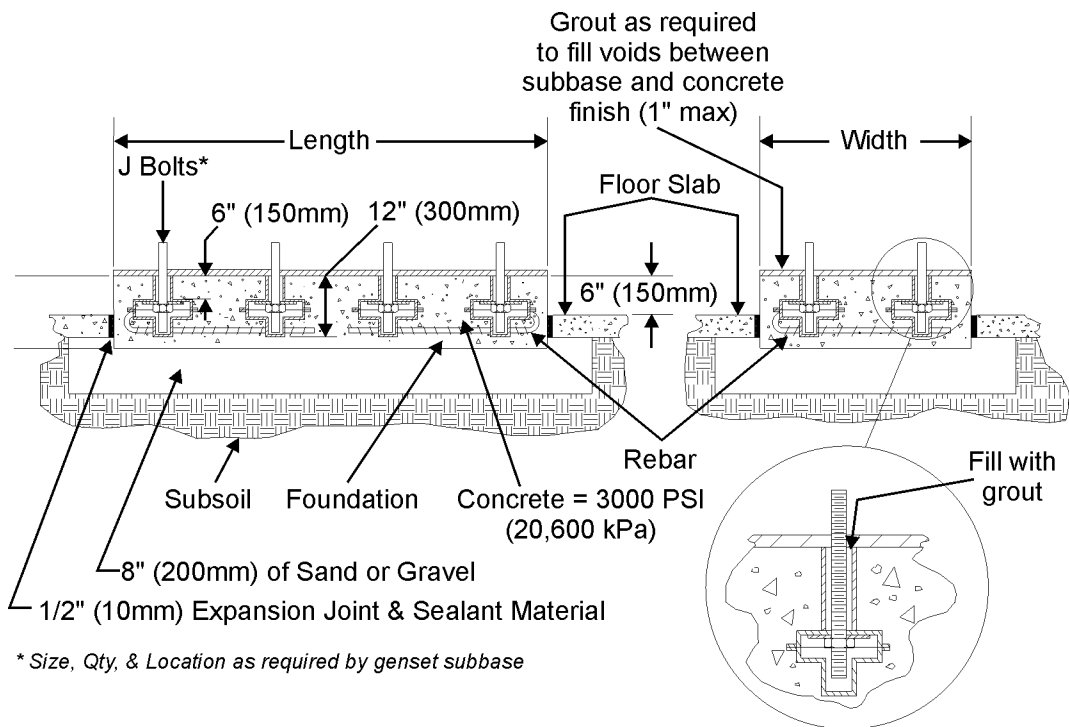

**Figure 6. Typical Foundation**

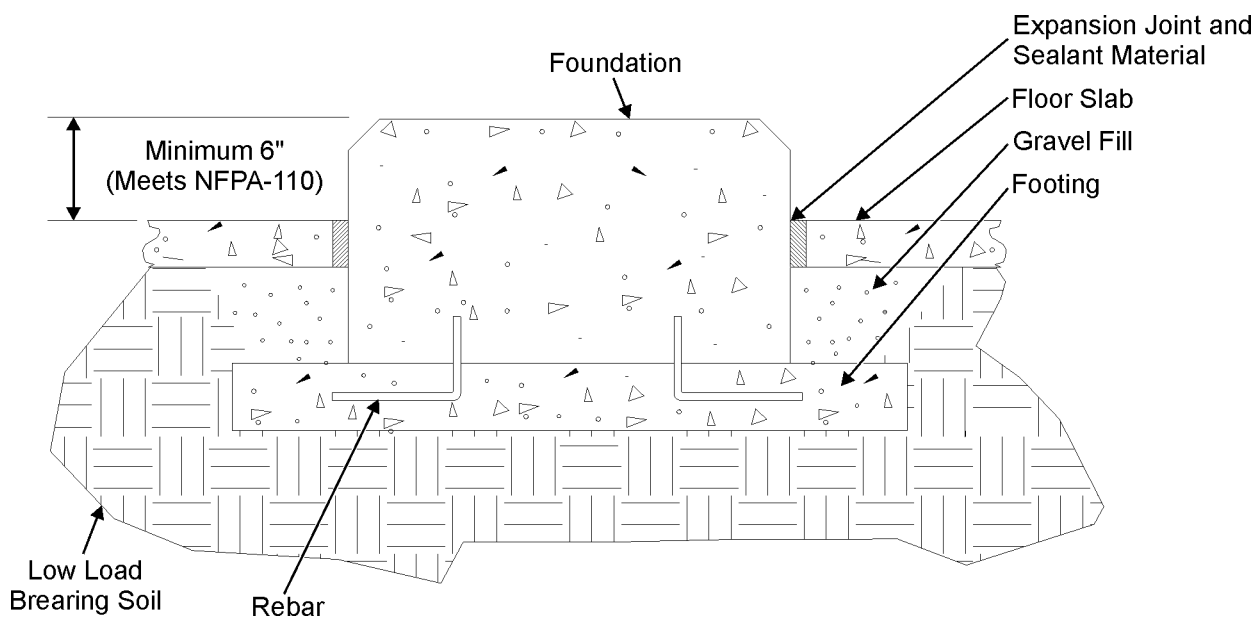

**Figure 7. Typical Footing**

# MOUNTING THE GENERATOR SET

## General Information

Generator set installations must be engineered so the generator set will function properly under the expected load conditions. Use these instructions as a general guide only. Follow the instructions of the consulting engineer when locating or installing any components. The complete installation must comply with all local, state, and federal building codes, fire ordinances, and other applicable regulations.

Always consider the following prior to installation:

- Level mounting surface
- Adequate cooling air
- Adequate fresh induction air
- Discharge or circulated air
- Discharge of exhaust gases
- Electrical connections
- Accessibility for operation and servicing
- Noise levels
- Vibration isolation

## Location

The generator set location is decided mainly by related systems such as ventilation, wiring, fuel, and exhaust. The set should be located as near as possible to the main power distribution panel.

The generator set should be installed in a protected location that is guarded against vandalism, theft, and unauthorized tampering.

Always provide an optimal installation site that is away from extreme ambient temperatures and that will provide maximum protection against adverse weather conditions.



### WARNING

Incorrect installation or service can result in severe personal injury or death, and/or equipment damage. Only qualified service personnel should be allowed to perform electrical and mechanical component installation.



### DANGER

**NEVER** install genset over combustible materials. Locate genset such that combustible material can not accumulate under the assembly. The possibility exists of fire or explosion, causing damage to the equipment and or severe bodily harm even death!

## Mounting

Mount the generator set on a substantial and level base such as a concrete pad described previously in the Foundation section. Provide properly sized mounting bolts to secure the vibration isolators to the skid using flat or bevel washers and hexagonal nut for each bolt. (See Figure 8 below.)

The isolators should be located as shown on the genset outline drawing.

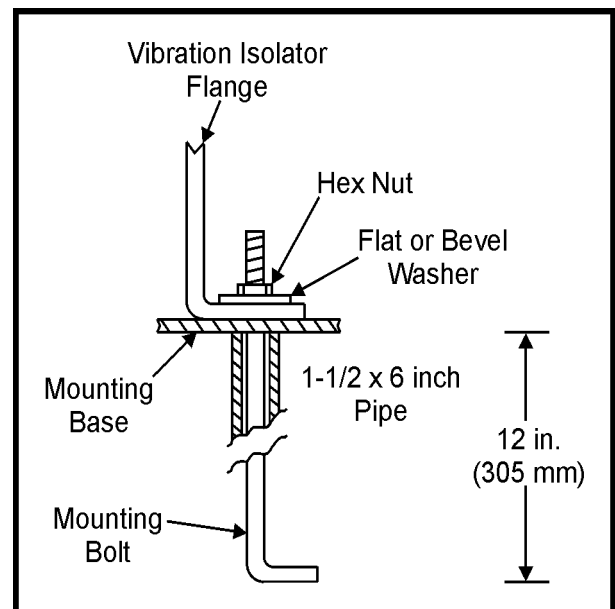
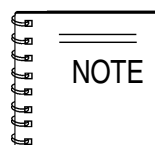

Figure 8. Bolt Diagram

## Vibration Isolators

Steel spring isolators can provide up to 98% reduction in the force of vibration transmission. Locate the vibration isolator between the genset skid and foundation in accordance with the installation drawing. The installation may require 4, 6, 8, or 12 vibration isolators.



Always consult local air quality authorities before completing your construction plans. In most instances, standby power units must be registered with the local air pollution control district.

# MOUNTING — VIBRATION ISOLATORS

## Vibration Isolators

### Installation and Adjustment Procedure

1. Place the vibration isolators on the genset support structure. The isolators should be shimmed or grouted to ensure that all of the isolator bases are within 0.25 inch (6 mm) elevation of each other. The surface the isolator bases rest on must also be flat and level. (See Figure 9 to the right.)
2. Loosen the snubber lock nuts so that the top plate of the isolator is free to move vertically and horizontally. Be sure the top plate is correctly aligned with the base and springs.
3. Place the genset onto the isolators while aligning the skid's mounting with the threaded isolator hole. The top plates will move down and approach the base of the isolator as the weight of the generator is applied.
4. Once the genset is in position, the isolators may require adjusting so that the set is level. The isolators are adjusted by inserting the leveling bolt through the skid and into the isolator (the leveling bolt's locking nut should be threaded up towards the bolt head). The leveling bolt will adjust the clearance between the top plate and the isolator base. A nominal clearance of 0.25 inch (6 mm) or greater is desired. This will provide sufficient clearance for the rocking that occur during start-up and shutdown. If the 0.25 inch clearance is not present, turn the leveling bolt until the desired clearance is achieved.

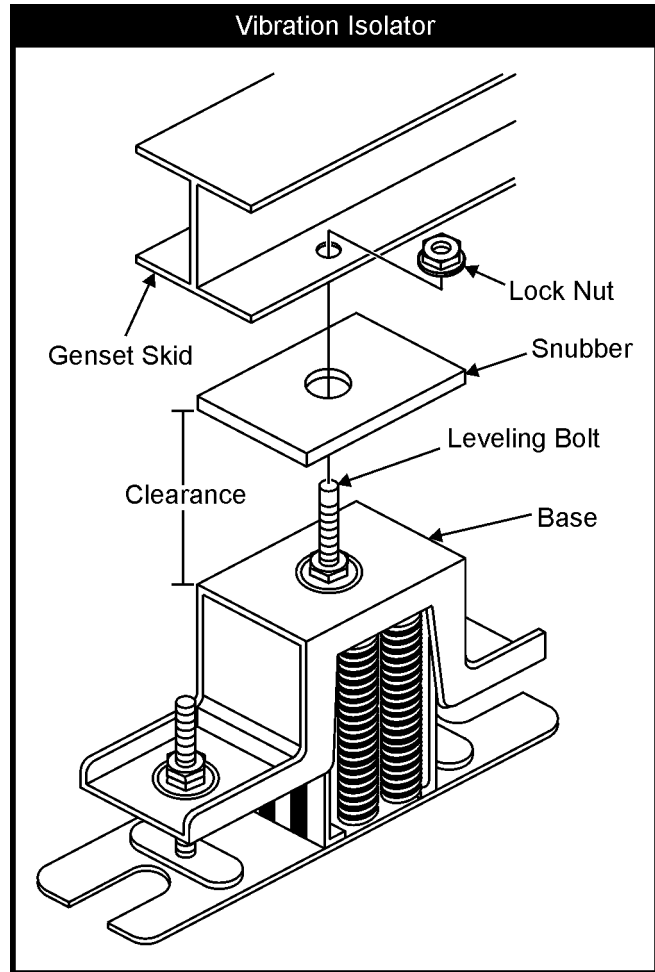
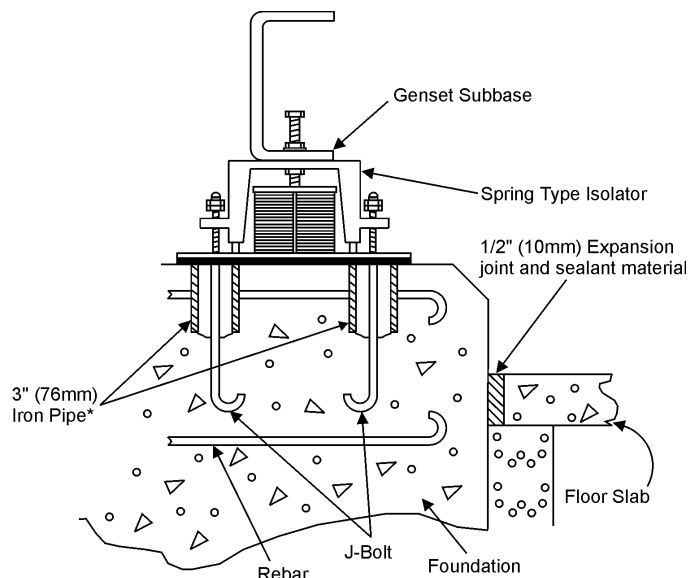

Figure 9. Vibration Isolator

### Set mounted radiator-cooled generator sets:

Make sure radiator skid and engine/alternator skid are level with each other after adjusting isolators. Improper fan belt alignment may occur if the unit is not level.

5. Adjust the leveling bolts until the set is level and sufficient clearance still remains. The clearance on all isolators should be roughly equal. Once all isolators have been set, lock the leveling bolt in place with the lock nut.
6. The snubber nuts must remain loose and therefore provide better isolation between the genset and support structure.



\*Use of expansion bolts also acceptable

Figure 10. Vibration Isolator Installation

## MECHANICAL CONNECTIONS

### Introduction

After considering all applicable codes and laws and finding a suitable location site for the generator set, the installer should consider the mechanical connections that will be necessary to make during installation. The four (4) systems that could require mechanical connections are the following:

- Fuel system
- Exhaust system
- Ventilation system
- Cooling system

### Fuel System Installation

Proper installation of the fuel system is essential in obtaining proper genset performance, safe working conditions, and preventing property and environmental damage.

When planning an installation, check state and local codes regarding fuel storage and handling. Piping and fuel system components must conform to these regulations. Most applications in the United States require that storage tanks, day tanks, and subbase fuel tanks be UL listed. The UL listing indicates that the tank has conformed to a series of construction and testing standards. In addition, most tanks must conform to National Fire Protection Association (NFPA) construction and installation requirements. The three NFPA codes that apply to day tanks and subbase fuel tanks are NFPA 30, Flammable and Combustible Liquids Code; NFPA 37, Standard for Installation and Use of Stationary Combustible Engine and Gas Turbines and NFPA 110, Standard for Emergency and Standby Power Systems.

The main components of a typical diesel fuel system are the fuel storage tank, fuel lines, transfer fuel tanks or day tanks and auxiliary fuel pumps or lift pumps. Fuel storage tanks may be located indoors or outdoors, providing they meet local code requirements. The fuel supply tank should be located near the diesel engine to enable the engine mounted fuel transfer pump to operate within its capability. Fuel filters and sediment or fuel/water separators must be easily accessible for regular and scheduled maintenance. It is important to have a clean installation, making every effort to prevent entrance of moisture, dirt or contaminants of any kind. Clean all fuel system components before installing.

Use only compatible metal fuel lines to avoid electrolysis when fuel lines must be buried. Buried fuel lines must be protected from corrosion. Use a *flexible* section of tubing between the engine and fuel supply line to prevent vibration damage.

Refer to the generator set manual for outline drawings and detailed information.

### Diesel Fuel

MQ Power Industrial generator-sets use ASTM No. 2 Diesel fuel. If an alternate diesel fuel is required, consult the appropriate engine manual.



## WARNING

**NEVER** use galvanized or copper fuel lines and fittings for fuel tank connection. Condensation in the tank and fuel lines combines with the sulfur in diesel fuel to produce sulfuric acid. The molecular structure of the copper or galvanized lines reacts with the acid and contaminates the fuel, which can clog filters and damage the engine fuel injection pump.

# MECHANICAL INSTALLATION — FUEL SYSTEM

## Supply Tank

Locate the supply fuel tank as close as possible to the generator set and within the five (5') foot (1.5 m) lift capacity of the engine fuel pump. Any fuel tank transfer pump capacity and supply piping should be sized on the basis of the maximum fuel flow rating. Refer to the generator set data sheet for detailed fuel consumption data.

If the main fuel tank is installed below the lift capabilities of the standard engine fuel pump, a transfer tank (referred to as a day tank) and auxiliary pump also be required. If an overhead main fuel tank is installed, a transfer tank and float valve will be required to prevent fuel head pressures from being placed on the fuel system components.

## DANGER

Fuel leaks create fire and explosion hazards which can result in severe personal injury or **death!** Always use flexible tubing between engine and fuel supply to avoid line failure and leaks due to vibration. The fuel system must meet applicable codes.

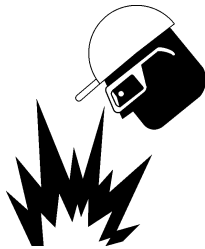

## Subbase Tank

Base mounted or subbase fuel tanks are used to store fuel directly underneath the engine-generator set, eliminating the need for a remote main fuel supply tank and/or auxiliary fuel transfer pumps. This mounting arrangement offers the convenience of having a fuel supply tank mounted at the generator.

These tanks have been designed to be contained in a rectangular base on which the engine-generator set is mounted. Generally, these tanks only increase the height of the generator set since the tank base is usually matched to the generator skid dimension. For many installations, this type of tank offers advantages over above ground and below ground tanks due to stringent environmental laws making it difficult or impossible to gain necessary approvals.

Subbase fuel tanks are available with the UL142 listing under the special purpose tank category of NFPA. These tanks are available in various capacities and designs. When a subbase fuel tank is used, the tank should be designed with a stub-up area on the generator-end of the tank.

This feature allows for an open area on the tank assembly whereby electrical terminations can be brought up underneath the engine-generator for final termination (refer to Electrical Connections section).

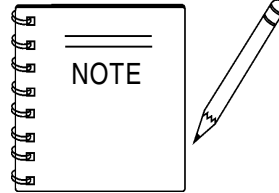

Using oversized subbase fuel tanks, where the tank is larger than the skid of the generator, can cause difficulty in completing final electrical connections. The tank should be designed with a stub-up area on the generator-

end of the tank. However, depending on the placement of the engine-generator on the tank, feeder terminations may not rise in a close proximity to the circuit breaker. This could require the feeder conductors to enter the circuit breaker enclosure from the side or top, necessitating special fittings and/or hardware. Be sure to check with the local inspection authority before proceeding

## Day Tank

Fuel day tanks are used when the engine fuel pump does not have the capacity to draw the fuel from the supply tank; or the supply tank is overhead and presents problems of high fuel head pressure for the system.

In high ambient conditions, the day tank temperature might need to be considered. War fuel returning from the engine fuel injection pump should not be returned to the day tank if possible. As fuel temperature increases, fuel density and lubricity decrease, reducing maximum power output and lubrication of fuel handling parts such as pumps and injectors. This *may* be avoided by returning the fuel back to the supply tank rather than the day tank.

## Supply Tank Lower than Engine Installation

If a supply tank is lower than the engine, the day tank is installed near the generator set and within the engine fuel pump lift capability, but below the fuel injection system. Install an auxiliary fuel pump as close as possible to the supply tank to pump fuel from the supply tank to the day tank. A float switch in the day tank controls operation of the auxiliary fuel pump.

The supply tank top must be below the day tank top to prevent siphoning from the fuel supply to the day tank. Provide a return line from the engine injection system return connection to the day tank (near the top). Provide a day tank overflow line to supply tank in case the float switch fails to shut off the fuel transfer pump.

## DANGER

Failure to provide an overflow line to the supply tank from the day tank can cause spilled fuel, safety hazards, and damage to equipment. Wipe up any spilled fuel immediately. Spilled fuel if ignited can cause a fire or explosion, causing damage to the equipment and severe bodily harm even **death!**

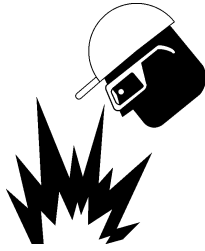

### Supply Tank Higher than Engine Installation

If a supply tank is higher than the engine, the day tank is installed near the generator set, but below the fuel injection system. Fuel lines should at least be as large as the fuel pump inlet. The engine fuel return line must enter the day tank.

Include a shut-off valve in the fuel line between the fuel supply tank and the day tank to stop fuel flow when the generator set is not in use and the battery is disconnected (Off Mode).

### Engine Fuel Connections

Identification tags are attached to the fuel supply line and fuel return line connections by the factory. Flexible lines for connecting between the engine and stationary fuel line are supplied as standard equipment.

## WARNING

Fuel leaks and spills can cause environmental contamination. Make sure the area surrounding the fuel tanks and lines will prevent fuel from entering soil, sewers, and water.

# MECHANICAL INSTALLATION — FUEL SYSTEM

## Diesel Fuel Supply

Consider the following when installing a diesel fuel supply system:

- Fuel supply tank construction, location, installation, venting, piping, testing, and inspection must comply with all applicable codes. In addition, see NFPA Standards No. 30 and No. 37.
- Fuel supply tanks must be adequately vented to prevent pressurization, have provisions for manually draining or pumping out water and sediment, and have at least a five percent expansion space to prevent fuel spillage when the fuel heats up and expands.
- The fuel lift pump, day tank transfer pump, or float valve seat should be protected from fuel supply tank debris by a pre-filter or sediment bowl with a 100 to 120 mesh element.
- The supply tank must hold enough fuel to run the genset for the prescribed number of hours (NFPA No. 110 Class designation) without refueling. Tank sizing calculation should be based on the hourly fuel consumption rates on the genset specification sheet.
- For emergency power systems, codes might not permit the fuel supply to be used for any other purpose, or may specify a drawdown level for other equipment that guarantees the fuel supply for emergency power use.
- The cetane rating of No. 2 heating oil is not high enough for dependable starting of diesel engines in extreme cold weather climates. Therefore, separate supply fuel tanks for emergency power and building heating systems may have to be provided.
- Approved flexible fuel hose must be used for connections at the engine to prevent damage from genset movement and vibration.
- Diesel fuel lines should be black iron pipe. Cast iron and aluminum pipe and fittings must NOT be used because they are porous and can leak.
- Galvanized fuel lines, fittings, and tanks SHOULD NOT be used because the galvanized coating reacts with the sulfuric acid that forms when the sulfur in the fuel combines with tank condensation, resulting in debris that can clog fuel pumps and filters.
- Although copper has been used for diesel fuel lines in the past, black iron pipe is preferred. Diesel fuel polymerizes (thickens) in copper tubing during long

periods of standby. This can cause the fuel injectors to clog.

- Refer to the engine specification sheet for the maximum fuel inlet and return restrictions, the maximum fuel flow, and the fuel consumption. Then refer to Table 10 for the minimum hose and pipe sizes for connections to a supply tank or day tank that is relatively close to the set at approximately the same elevation. Hose and pipe size should be based on the maximum fuel flow rather than the fuel consumption (*The maximum fuel flow can be twice the full-load fuel consumption*). It is highly recommended that the fuel inlet and return restrictions be checked before the set is placed into service.
- Separate fuel return lines to the day tank or supply tank must be provided for each generator set in a multiple-set installation to prevent the return lines of idle set from being pressurized. Also, a fuel return line must NOT include a shut-off device. Engine damage will occur if the engine is run when the fuel line is shut off.
- A day tank is required whenever pipe friction and/or supply tank elevation, either below the fuel pump inlet or above the fuel injectors, would cause an excessive fuel inlet or return restriction.
- For critical start applications, where gensets are paralleled or must satisfy emergency start-time requirements, it is recommended that a fuel tank or reservoir be located such that the lowest possible fuel level is not less than 6 inches (150 mm) above the fuel pump inlet. This will prevent air from accumulating in the fuel line while the genset is in standby, eliminating the period during start-up when the air has to be purged.

Table 10. Minimum Fuel Supply / Return Hose and Pipe Sizes

Maximum GPH Fuel Flow	Fuel Supply Line				Fuel Return Line			
	0-10 Feet (0-3 Metres)		10-50 Feet (3-15 Metres)		0-10 Feet (0-3 Metres)		10-50 Feet (3-15 Metres)	
	Flex Hose Size	Pipe I.D. Inches (mm)	Flex Hose Size	Pipe I.D. Inches (mm)	Flex Hose Size	Pipe I.D. Inches (mm)	Flex Hose Size	Pipe I.D. Inches (mm)
0-15	No. 6	5/16 (7.9)	No. 8	13/32 (10.3)	No. 4	3/16 (4.8)	No. 6	5/16 (7.9)
16-20	No. 8	13/32 (10.3)	No. 10	1/2 (12.7)	No. 4	3/16 (4.8)	No. 6	5/16 (7.9)
21-80	No. 10	1/2 (12.7)	No. 12	5/8 (15.9)	No. 8	13/32 (10.3)	No. 10	1/2 (12.7)
81-100	No. 12	5/8 (15.9)	No. 16	7/8 (22.3)	No. 8	13/32 (10.3)	No. 10	1/2 (12.7)
101-160	No. 16	7/8 (22.3)	No. 16	7/8 (22.3)	No. 10	1/2 (12.7)	No. 12	5/8 (15.9)
160<	No. 16	7/8 (22.3)	No. 16	7/8 (22.3)	No. 12	5/8 (15.9)	No. 12	5/8 (15.9)

Based on four straight fittings, two 90° fittings, and minimal fuel lift height

## Fuel Storage Regulations

Use extreme care when using, transporting, and storing fuel. Every measure should be taken to protect personnel and the environment from the dangers of fuel. Fuel supply tank design and installation in North America is controlled by regulations that are generally written for fire protection and environmental protection. It is very important to adopt safe methods of storing fuel and to meet all applicable codes and laws.

## Fire Protection

Fire protection regulations adopt by reference one or more of the National Fire Protection Association (NFPA) standards. These standards cover the maximum amount of fuel that can be stored inside buildings, fuel piping systems, the design and construction of fuel tanks, fuel tank locations, drainage provisions, etc. Local fire marshals may have more restrictive requirements or interpretations of requirements than national standards.

## Environmental Protection

Environmental protection regulations exist at both federal and state levels. Different sets of regulations apply to underground versus above-ground fuel storage tanks. These regulations cover design and construction standards, registration, tank testing, leak detection, closure requirements, preparation of spill prevention plans and provisions for financial responsibility and trust fund coverage.

In some cases, exemptions from regulation are granted for underground and above ground diesel storage tanks serving on-site emergency gensets where the capacity of the facility storage tanks is 1,320 gallons or less, no single tank has a capacity in excess of 660 gallons, and the fuel is consumed at the facility (not dispensed).

Federal regulation of above ground storage tanks exempts facilities where the storage capacity of diesel fuel is 1,320 gallons or less in non-buried storage provided no single container has a capacity in excess of 660 gallons and where underground tanks are used only for on-site emergency gensets.

OSHA Standards for Flammable and Combustible Liquids, exempts above ground installations made in accordance with NFPA 37. Exemption status from state regulation must be verified before installation.

## Environmental Protection (continued)

Even when an installation is exempt from regulation, it should be recognized that cleanup expenses may be very costly for even small amounts of fuel spillage from leaks, overfilling, etc. The trend in diesel fuel storage for on-site gensets, both indoors and outdoors, has been towards Underwriter Laboratories Listed above ground dual-wall subbase tanks with leak detection.

Additional references include:

- **UL 142, Steel Above-ground Tanks for Flammable and Combustible Liquids** — This safety standard covers design, construction, and testing requirements for third-party certification.
- **Uniform Fire Code, Western Fire Chiefs Association and International Conference of Building Officials** — This standard covers piping, valves, fittings, stationary storage tanks (above ground and underground; inside, under, and outside buildings), etc.
- **API 1615, Installation of Underground Petroleum Product Storage Systems, American Petroleum Institute (API)** — This standard covers pre-installation site analysis, material, and equipment requirements, removal and disposal of used storage systems, excavation, cathodic protection, detection of releases, piping, backfilling and vapor recovery.

# MECHANICAL INSTALLATION — EXHAUST SYSTEM

## Exhaust System Installation

A proper exhaust system installation will ensure safe working conditions and maximum engine efficiency. All MQ Power-KD Series, standby, engine-generators have factory-designed mufflers, exhaust connectors and rain caps available for each model. For best performance and ease of mounting, it is recommended the factory components be used whenever practical. Refer to Table 11 for a complete listing of factory recommended exhaust silencers for each model. A properly installed exhaust system routes engine exhaust to a safe location where the exhaust can dissipate with fresh air. The exhaust system disperses engine exhaust fumes, soot, and noise away from people, vents and buildings. It is essential to the performance of the engine-generator set that the installed exhaust system does not exceed the engine manufacturer's maximum exhaust backpressure limit. Pressure drop of exhaust system includes losses due to piping, silencer and termination. High backpressure can cause a decrease in engine efficiency or increase in fuel consumption, overheating, and may result in a complete shut down of the engine-generator. Potential damage could result. Refer to Table 11 for backpressure limits for each model generator set.

## Field Installing A Generator Exhaust System

All work should be completed by qualified persons familiar with the installation, construction and operation of generator sets. All work should be completed in accordance with the National Fire Protection Association (NFPA), Uniform Building Code (UBC) and other state or local codes.

Some generators require little or no engine exhaust component installation. In most cases, if the generator set is equipped with a manufacturer's installed, weather protective enclosure, the engine exhaust system is generally already mounted and plumbed within or on top of the generator enclosure. There is little or no site work that has to take place. Check with the engine-generator manufacturer for specific details.

## WARNING



**DO NOT** use exhaust heat to warm a room, compartment, or storage area.

## WARNING



Weight applied to the engine manifold can result in turbocharger damage. Support the muffler and exhaust piping so no weight or stress is applied to the engine exhaust elbow.

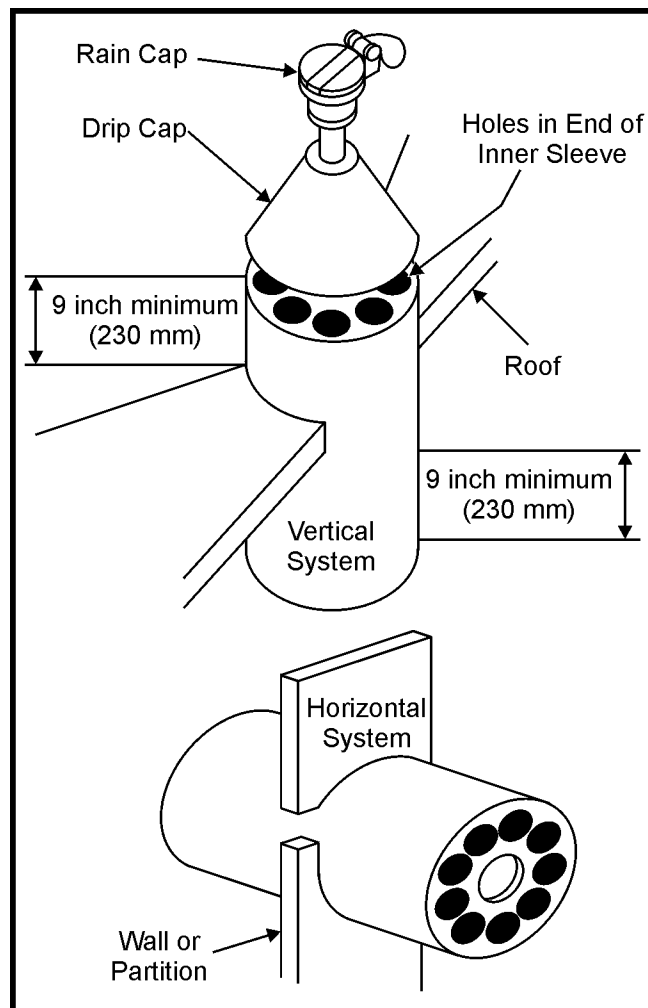

Figure 11. Mounting Exhaust Thimble

## DANGER

Inhalation of exhaust gases can result in severe personal injury or **death!**

Use extreme care during installation to provide a tight exhaust system. Terminate exhaust pipe away from enclosed or sheltered areas, windows, doors, and vents.



## MECHANICAL INSTALLATION — EXHAUST SYSTEM

If the engine-generator is not equipped with a factory mounted exhaust system, such as a unit mounted inside a building or room, the installation of the engine exhaust system has to be planned very carefully. When installing an exhaust system on an open or un-housed generator, **consider the following recommendations:**

1. After a thorough review of the exhaust installation requirements, select the engine silencer, piping and exhaust fittings based on the engine manufacturer's maximum exhaust backpressure limits.
2. Use flexible, corrugated stainless steel exhaust tubing, 12 to 18 inches (305 - 457 mm) in length, to connect the exhaust silencer to the engine exhaust outlet. This tube or flex connector allows for thermal expansion and engine vibration.
3. Be sure to support the exhaust system (muffler, piping, etc.) to minimize the total weight applied to the engine exhaust manifold and exhaust outlet elbow or turbocharger connection.
4. Exhaust piping should conform to NFPA 37, Stationary Engines and Gas Turbines design practices, and any applicable local codes.
5. Avoid sharp bends in the exhaust piping by using sweeping, long radius elbows and provide adequate support for muffler and all associated piping.
6. Pitch a horizontal run of exhaust pipe **DOWNWARD** to allow moisture condensation to drain away from the engine. If an exhaust pipe must be turned **UPWARD**, install a condensation trap at the point where the rise begins. See Figure 12.
7. Shield or insulate exhaust piping if there is any possibility of personal contact. Allow at least 12 inches (305 mm) of clearance where piping passes close to a combustible wall or partition.
8. Use an approved, insulated & ventilated, metal thimble where exhaust pipes pass through a combustible wall or partition.
9. Always pipe exhaust gases to the outside of any building or room. Route the engine exhaust away from any building air inlets to avoid engine exhaust fumes from entering the building fresh air intake. Some codes specify that the exhaust outlet terminate at least 10-feet (3 meters) from the property line, 3-feet (1 meter) from an exterior wall or roof, 10-feet from openings into buildings and at least 10-feet above any adjoining grade.
10. The installation of a rain cap is required for the discharge end of the exhaust system piping, if the piping is vertical. The rain cap clamps onto the end of the pipe and opens from the exhaust discharge force from the generator set while running. When the generator set is stopped, the rain cap automatically closes, protecting the exhaust system from rain, snow, etc.
11. Once the exhaust system has been installed, it is important to regularly inspect the exhaust system both visually and audibly to see that the entire system remains sealed against leakage and safe for operation.



### WARNING

**DO NOT** use flexible tubing to form bends or to compensate for misaligned piping.

- Reduce corrosion from condensation by installing the muffler as close as practical to the engine.
- Support mufflers and piping by noncombustible hangers or supports. **DO NOT** use the engine exhaust outlet for support. Weight on the engine exhaust outlet can cause damage to the engine exhaust manifold or reduce the life of a turbocharger.
- Schedule 40 black iron pipe is recommended for exhaust piping.
- Pipe bend radius should be as long as practical.
- **NEVER** use exhaust tubing and piping of smaller diameter than the exhaust outlet. Verify the back pressure limitation of the engine, and use exhaust tubing and piping of the appropriate size throughout the exhaust system.
- **DO NOT** use piping that is larger than necessary to avoid corrosion from condensation. This also reduces the exhaust gas velocity available for dispersing the exhaust gases up and into the outdoor wind stream.
- Keep exhaust pipe diameter changes to a minimum to avoid friction loss.
- A genset should not be connected to an exhaust system servicing other equipment, including other gensets. Soot, corrosive condensation, and high exhaust gas temperatures can damage idle equipment served by a common exhaust system.

## MECHANICAL INSTALLATION — EXHAUST SYSTEM

- Thermally insulate exhaust piping and mufflers as required to prevent burns from accidental contact, prevent activation of fire detection devices and sprinklers, reduce corrosion due to condensate, and reduce the amount of heat radiated to the generator room.

### WARNING

Engine exhaust manifolds and turbocharger housing, unless approved by the engine manufacturer, must never be insulated. This can result in material temperatures that can destroy the manifold and turbocharger.

- Exhaust piping must be routed at least 12 inches (305 mm) from combustible construction. Use approved thimbles where exhaust piping must pass through combustible walls or ceilings.
- Exhaust pipe (steel) expands approximately 0.0076 inches per foot of pipe for every 100°F rise in exhaust gas temperature above room temperature (1.14 mm per 100°C rise). It is recommended that flexible, corrugated stainless steel tubing be used to take up expansion in long, straight runs of pipe.
- Horizontal runs of exhaust piping should slope downwards, away from the engine, to the outdoors or to a condensation trap.
- A condensation drain trap and plug should be provided where piping turns to rise vertically. See Figure 12.
- A rain cap should be used if the exhaust outlet is vertical.
- The exhaust system must terminate outdoors at a location where engine exhaust will disperse away from buildings, animals, and building air intakes. In addition, the exhaust must not be allowed to blacken walls or windows with soot.
- It is highly recommended that the exhaust system be carried up as high as practical on the downwind side of buildings and that it is discharged straight up to maximize dispersal.

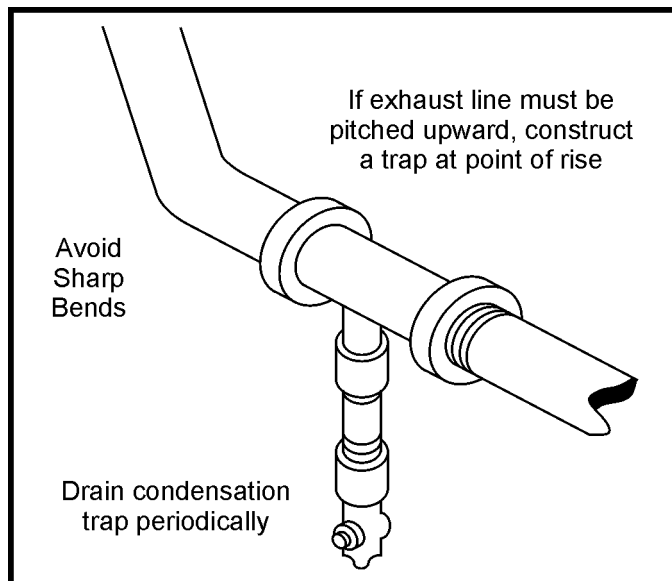
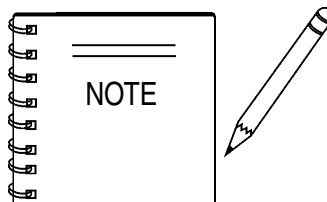

Figure 12. Condensation Trap



Some codes specify that the exhaust outlet terminate at least 10 feet (3 meters) from the property line, 3 feet (1 meter) from an exterior wall or roof, 10 feet from openings into buildings, and at least 10 feet above the adjoining grade.

### WARNING

Exhaust back pressure must not exceed the allowable back pressure of the engine. Excessive exhaust back pressure reduces engine power, engine life, and may lead to high exhaust temperatures and smoke.

### WARNING

Exhaust pipes are very hot and they can cause severe personal injury or death from direct contact or from fire hazard. Shield or insulate exhaust pipes if there is danger of personal contact or when routed through walls or near other combustible materials.

# MECHANICAL INSTALLATION — EXHAUST SYSTEM

## Exhaust System Installation Reference Data

The following Tables are provided for reference when installing the exhaust system.

MQ Power Generator Model Number	Silencer Manufacturer Name	Silencer Model Number	Inlet/Outlet Diameter Inches (MM)	Maximum Allowable Back-Pressure Inches-WC	Total Weight of Silencer lbs. (Kg.)
KD75V	COWL	TS30TR	3 (76.2)	20	34 (15.42)
KD100V	COWL	TS30TR	3 (76.2)	28	34 (15.42)
KD115V	COWL	TS40TR	4 (101.6)	28	50 (22.67)
KD150V	COWL	TS40TR	4 (101.6)	28	50 (22.67)
KD175V	COWL	TS45TR	4.5 (114.3)	40	60 (27.21)
KD200V	COWL	TS45TR	4.5 (114.3)	40	60 (27.21)
KD250V	COWL	TS60TR	6 (152.4)	28	94 (42.63)
KD300V	COWL	TS60TR	6 (152.4)	40	94 (42.63)
KD350V	COWL	TS60TR	6 (152.4)	40	94 (42.63)
KD400V	COWL	TS60TR	6 (152.4)	40	94 (42.63)
KD450V	COWL	TS80TR	8 (203.2)	28	180 (81.64)
KD500V	COWL	TS80TR	8 (203.2)	28	180 (81.64)

**Table 12. Cross-Sectional Areas of Openings of Various Diameter**

Diameter of Muffler Inlet (Inches)	Area of Muffler Inlet (FT <sup>2</sup> )	Diameter of Muffler Inlet (Inches)	Area of Muffler Inlet (FT <sup>2</sup> )
2	0.0218	5	0.1363
2.5	0.0341	6	0.1963
3	0.0491	8	0.3491
3.5	0.0668	10	0.5454
4	0.0873	12	0.7854

**Table 13. Equivalent Lengths of Pipe Fittings (Feet)**

Type of Fitting	Nominal Diameter (Inches)									
	2	2.5	3	3.5	4	5	6	8	10	12
Standard Elbow	5.3	6.4	8.1	9.6	11	14	16	21	26	32
Medium Elbow	4.6	5.4	6.8	8	9	12	14	18	22	26
Long Radius Elbow	3.5	4.2	5.2	6	7	9	11	14	17	20
45° Elbow	1.5	2	2.3	2.6	3	4	4.5	6	8	9
Standard Tee	13	14	17	19	22	27	34	44	56	67
18 Inch Flexible Tube	3	3	3	3	3	3	3	3	3	3
24 Inch Flexible Tube	4	4	4	4	4	4	4	4	4	4

**Table 14. Heat Losses from Uninsulated Exhaust Pipes and Mufflers**

Pipe Diameter Inches (mm)	Heat From Pipe BTU/MIN-FOOT (kj/Min-Metre)	Heat From Muffler BTU/MIN (kj/Min)
1.5 (38)	47 (162)	297 (313)
2 (51)	57 (197)	490 (525)
2.5 (64)	70 (242)	785 (828)
3 (76)	84 (291)	1,100 (1,160)
3.5 (98)	96 (332)	1,408 (1,485)
4 (102)	108 (374)	1,767 (1,864)
5 (127)	132 (457)	2,500 (2,638)
6 (152)	156 (540)	3,550 (3,745)
8 (203)	200 (692)	5,467 (5,768)
10 (254)	249 (862)	8,500 (8,968)
12 (305)	293 (1,014)	10,083 (10,638)

## Purpose of the Battery

The major function of the battery is to *supply current to start the engine*. The current required to crank the genset engine varies by model. Cranking current is dependent upon the engine stroke and bore, the number of cylinders, engine/starter ratio, circuit resistance, temperature, engine oil viscosity, and the accessory loads. A four-cylinder engine could require as much cranking current as an eight-cylinder engine with greater displacement. All of these factors are considered when an original equipment battery is specified by the engine manufacturer.

## How Batteries Work

When two unlike materials such as the battery positive and negative plates are immersed in sulfuric acid (the electrolyte), a battery is created and a voltage is developed. The voltage developed depends on the types of materials used in the plates and the electrolyte used. Electrical energy is produced by the chemical reaction between the different materials and the electrolyte. When the chemical reaction starts electrical energy flows from the battery as soon as there is a circuit between the battery positive and negative terminals.

Lead-acid storage battery voltage is determined by the materials used in its construction. The chemicals used are:

- Lead dioxide ( $\text{PbO}_2$ ) — the material on the positive
- Sponge lead ( $\text{Pb}$ ) — the material on the negative grid
- Sulfuric acid ( $\text{H}_2\text{SO}_4$ ) — the electrolyte

The battery also supplements the DC load requirements whenever the load excess the charging system's ability to deliver the necessary power. Charging systems will carry the electrical load under normal conditions. However, if the engine is at idle speed, the battery may have to supply a portion of the accessory load. The battery must supply the genset's electrical load requirements if the charging system fails.

The battery can also act as a voltage stabilizer in the charging system. Occasionally, very high transient voltages are generated in the electrical system. This may occur in the making or breaking of a circuit in the system. The battery partially absorbs and reduces these peak voltages thereby protecting sold-state components from damage.

## MQ Power Batteries

MQ Power Industrial Gensets use a heavy duty commercial grade, lead acid type, low water-loss batteries. These batteries do not need to be serviced (such as adding water), and when properly maintained only need to be replaced after the pro-rata date (usually 36 months).

Batteries are sized to meet or exceed engine manufacturer's ampere/hour starting requirements and comply with NFPA-110 requirements for engine cycle-cranking.

## Low Water-loss Batteries

A low water-loss battery is designed to relieve the consumer of routine maintenance requirements such as adding water during the service life of the battery. Low water-loss batteries produce very little gas at normal charging voltages and, therefore, the rate of water loss is very low. MQ Power battery rate of water loss is low enough that the venting systems can be completely sealed, except for small vent holes, and water additions are not necessary for the life of the battery.

The advantages of low water-loss batteries when compared to conventional batteries are:

- Do not require servicing
- Does not require activation and boost-charging prior to installation
- Greater overcharge resistance
- Reduced terminal corrosion
- Elimination of overfilling and possible addition of harmful impurities

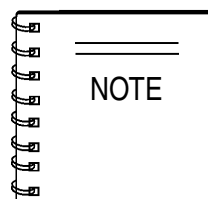

When replacing a genset battery, a battery at least equivalent to, and preferably greater than the original battery ratings is recommended.

# MECHANICAL INSTALLATION — BATTERY SYSTEM

## ENGINE STARTING SYSTEM

### *Battery Starting Systems*

Battery starting systems for generator sets are 12 volt or 24 volt DC (Figure 13). When installing a battery system to start a generator set, consider the following:

- See the Battery Safety Instructions on page 9.
- Batteries must have enough capacity to provide the cranking motor current indicated on the genset specification sheet. The batteries may be either lead-acid or nickel-cadmium. Refer to the dealer for approved battery brand names.
- A high output engine-driven alternator and automatic voltage regulator are provided with the genset to recharge the batteries during operation.
- For most emergency power systems, a float-type battery charger, powered by the normal power source (commercial power), must be provided to keep the batteries fully charged during standby. See the battery charger section for more information.
- Local codes or site conditions may require battery heaters to maintain a minimum battery temperature of 50°F (10°C) if the battery is subject to freezing temperatures.

- Standard gensets include battery racks and battery cables.
- Battery cable resistance must not result in a voltage drop between the battery and the starter motor of more than 1 volt for 12 volt systems or more than 2 volts for 24 volt systems.

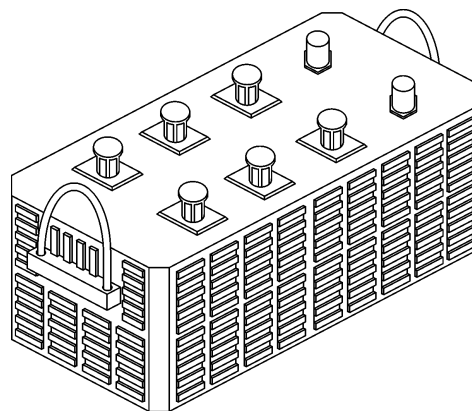

Figure 13. Typical Lead Acid Type Battery

## **WARNING**

Electrolyte is an acid and must be handled with caution. Servicing instruction from the electrolyte manufacturer must **ALWAYS** be followed to ensure safety. Serious injury can result from careless handling and non-compliance to safety handling instructions.

Overfilling the battery may cause the electrolyte to overflow resulting in corrosion to nearby components. Immediately wash off any spilled electrolyte (battery acid). Additionally, when connecting the positive (+) cable to the battery's positive (+) terminal post, **DO NOT** allow contact of the wrench or any metallic part to come in contact with the battery's negative (-) terminal post. This may result in an electrical short circuit or an explosion.



# MECHANICAL INSTALLATION — NEW BATTERY

## New Battery Installation

Before handling battery, refer to page 9 for *battery safety instructions*.

Replacement batteries should equal or exceed the specified battery ratings. Replacing the original battery with one that has a lower capacity may result in poor performance and shorter life. If the replacement battery has considerably less capacity than the specified battery rating, it may not crank the engine at cold temperatures. Difficulty may also be experienced in cranking high compression engines when they are hot. The *hot start* condition can impose a cranking load on the battery equal to loads experienced at cold temperatures.

A premium battery with higher capacity than the specified battery rating will provide a safety factor that will result in longer battery service.

If the electrical load of the vehicle has been increased by the addition of accessories, and engine cranking occurs frequently, a larger alternator may be required. A larger alternator will provide increased output at low speed operation and will improve battery performance.

A replacement battery **MUST** have the same voltage and polarity specified. Be sure the replacement battery is dimensionally correct and compatible for the battery rack. To insure a perfect fit for the replacement battery, it should be the same BCI Group Size as the original battery.

## Preparation of Charged and Wet Batteries

*All batteries should be fully charged and in proper working order before installation.*

If a charged and wet replacement battery is being installed, be sure the specific gravity is at least 1.250 or higher and the battery voltage is at least 2.1 volts per cell. If the specific gravity is below 1.250, or the voltage is below 2.1 volts per cell, the battery should be charged.

### CAUTION

If it should become necessary to dilute concentrated sulfuric acid to a lower specific gravity **ALWAYS** pour the acid into the distilled water — do this slowly — **NEVER** pour water into acid.

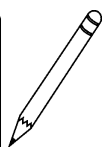
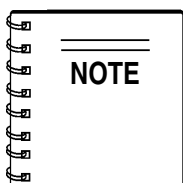

Use only **distilled** water in the battery. Tap water can **reduce** the operating life of the battery.

## Preparation of Dry Charged & Charged and Moist Batteries

*Dry charged and charged and moist batteries must be activated as described below before they can be used:*

### Dry Charged Batteries — Activation

1. Fill each cell of the battery to the top of the separators with the correct battery-grade electrolyte as specified in the manufacturer's instructions. Using higher or lower specific gravity electrolyte than that recommended can impair battery performance. Filling each cell to the top of the separators allows for expansion of the electrolyte as the battery is boost charged.
2. When a manufacturer recommends filling gravities of 1.265 or higher, boost charge 12-volt batteries at 15 amps (12-volt heavy duty batteries at 30 amps) until the specific gravity of the electrolyte is 1.250 or higher and the electrolyte temperature is at least 60°F (15.5°C) are reached. (In tropical climates, lower filling specific gravities are recommended.  
If the ambient temperature is 32°F (0°C) or less, it is imperative that the above instruction be followed.
3. After boost charge, check level of electrolyte in all cells. If required, add additional electrolyte to bring all levels to the bottom of the vent wells. **DO NOT OVERFILL.** If the battery requires top-off while in service, add water. **NEVER ADD ACID** to a battery.

Following the above instructions will insure proper activation of the battery and result in satisfactory performance.

Dry charged batteries may be placed in service immediately after activation. However, to insure superior performance, the following additional steps are recommended:

Check the specific gravity of all cells. Under good storage conditions, the specific gravity upon activating a dry-charged battery will drop approximately 0.010 points and the temperature will rise 7° to 10°F (4° to 5.6°C) within twenty minutes of activation. A battery under these conditions requires little boost charging. However, should the specific gravity drop 0.030 points or more, with a corresponding increase in temperature, the negative plates become oxidized and the battery should be **FULLY RECHARGED** before use. Also, the battery should be recharged if one or more cells gas violently after the addition of electrolyte.

# MECHANICAL INSTALLATION — NEW BATTERY

## Dry Charged Batteries (continued)

After electrolyte is added, check the open circuit terminal voltage of the battery. If a 12-volt battery reads less than 10 volts, this is an indication of either a reverse cell, an "Open" circuit, or a shorted cell, and the battery should be replaced. When a dry charged battery has been activated and not put into service, it must be maintained, handled, and kept charged like any other wet battery.

## Charged and Moist Batteries — Activation

The activation characteristics of the charge and moist batteries differ from conventional dry charged batteries in initial fill level, specific gravity readings, and initial testing procedures.

These batteries are activated the same as dry charged batteries except each cell is filled to the bottom of the vent well. It is only necessary to let it stand 10 minutes after electrolyte is added. The specific gravity will typically fall to a range of 1.200 to 1.230 (corrected to 80°F [26.7°C]). This does not indicate low performance capability. After several days of charge and discharge in normal vehicle service, the specific gravity will rise and level out at a full charge value of 1.245 to 1.255.

To determine the performance capability of these batteries during initial activation, they should be given a load test following the 10 minute soak period.

The battery should not be load tested unless the electrolyte temperature is at least 60°F (15.5°C). Apply a test load equal to 1/2 the *cold cranking performance* at 0°F (-17.8°C). Read the voltage at 15 seconds and remove the load. If the battery temperature is 70°F (21°C) or higher and the voltage reading is 9.6 volts or more, the minimum required voltage is 9.5 for 12-volt batteries.

If the voltage readings are below the minimum values, charge the battery at a slow charge rate and retest. If the battery fails the second test, reject it.

## Removing Old Battery

Before removing the old battery, carefully note the location of the positive battery terminal and mark the polarity on the positive cable. By doing this, you will avoid installing the new battery reversed (which could damage the electrical system). Remove the *ground* cable connector first. This precaution will avoid damage to wiring, and/or the battery, by accidental "grounds" with tools.

Use the proper size box, or pen end wrench, when removing battery cables.

Inspect the battery tray for possible damage or corrosion. Be sure the tray and hold-down are mechanically sound and free from corrosion. Corroded parts may be cleaned with water (to which some household ammonia or baking soda has been added) and scrubbed with a stiff brush. Cleaned parts should be dried and painted. Do not paint the battery or terminals. Clean and tighten the *ground* connection. Tighten the starter relay and starter connections too.

## Cables

Battery cables must carry large starting currents with a minimum loss of voltage, since engine cranking speed is dependent on the voltage available at the starting motor.

Examine the cables to insure the insulation is intact and the terminal connectors and bolts are not corroded. Replace all unserviceable parts. Also consider replacing cables that have temporary terminal ends bolted on. Temporary or emergency terminals should be replaced with new cables as soon as possible. As the acid corrodes terminals and cables, their resistance increases and the voltage loss between the battery and the starter increases. This increase in resistance due to corrosion also restricts the flow of charging current to the battery. This condition will eventually cause the battery to become undercharged and the plates will become sulfated.

## Installation

Be sure the battery has been charged as described in this section. If using an MQ Power battery, charge the battery as described in the low water-loss battery installation on page 50 if needed.

Make sure the battery is level in the battery rack. Be sure there are no foreign objects lying in the tray that may cause damage to the bottom of the battery container. The hold-down should be tightened snugly, but not to the point where the battery cracks or distorted.

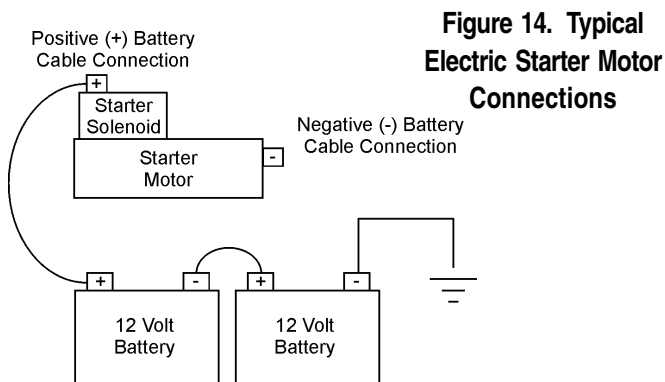

## Battery Testing

Before conducting any battery tests, refer to page 9 for *battery safety instructions*.

Low water-loss batteries of the latest design may incorporate flame-arrester vents to reduce the possibility of explosions caused by external sparks. Therefore, during charging and testing, the flame-arrester vents should remain in place.

Refer to the *low water loss battery testing chart* Figure 14.

### Step One (1) - Visual Inspection (See Flow Chart, Figure 15 on next page)

- a. Visually inspect the battery for container, cover, or terminal damage that may have caused leakage of electrolyte or internal damage. If serious damage is found, replace the battery.
- b. Check the condition and the size of the battery cables. Check for corrosion on the battery terminals and cable terminations. Corrosion on side terminal batteries may not be evident until the cables have been removed. Replace badly corroded cables or cables with defective terminations. Make certain the ground cable is making a good connection where it is grounded. Check the connection of the cable to the starter relay/or solenoid. Proceed to step two.

### Step Two (2) - Electrolyte Levels and State of Charge

Although these batteries are designed to preclude the need to add water, the volume of reserve electrolyte above the plates may eventually be depleted. In most cases, this will signal the end of the battery's useful life. Since many have sealed covers in place of filler caps, it may not be possible to check the electrolyte levels by looking directly into the cells. However, many low water loss batteries are contained in translucent plastic cases which may allow electrolyte levels to be seen. Other models utilize built-in hydrometers which also serve as electrolyte level indicators. If electrolyte levels can be seen and found to be low, check for a charging system malfunction.

If the electrolyte level is below the top of the plates in any cell, add water before proceeding further if vents are removable; if water cannot be added, replace the battery.

The battery must be at an adequate state of charge in order for the following load test to be valid. If the battery does not contain a built-in hydrometer, the state-of charge can be estimated with an accurate voltmeter.

### Step Two (continued)

- a. If the stabilized open circuit voltage is below 12.4 volts, charge the battery (or check battery charger connection). A stabilized voltage reading is assumed after the battery has remained on open circuit for a minimum of 4 hours or, preferably, overnight. When a hydrometer reading can be taken, a value of 1.225 @ 80°F (26.7°C) can be used instead of the 12.4 voltage reading. If the battery has a built-in hydrometer, follow the instructions of the manufacturer. After the battery is charged, proceed to step 2.c.
- b. If the state-of-charge of a battery cannot be determined, it must be charged. After the battery is charge, proceed to step 2.c.
- c. Remove surface charge by attaching load test leads to the terminals and applying a load equal to 1/2 of the cold cranking amps at 0°F (-17.8°C) rating of the battery for 15 seconds. Manufacturers may prescribe specific methods. Follow specific instructions when they are available. Proceed to step 3.
- d. If the stabilized voltage of the battery was 12.4 or above when it was first examined, or the built-in hydrometer indicated the battery was charge, proceed to step 3.

### Step Three (3) - Load Procedure

The load test is conducted to determine if the battery has adequate electrical performance or if it has to be replaced. This procedure is valid only if the battery is at or above the state of charge specified in step 2.

- a. Connect the voltmeter and load test leads to the battery terminals; be sure the load switch is in the "Off" position. Proceed to step 3.b.
- b. Apply a load test equal to 1/2 of the cold cranking rating of the battery at 0°F (-17.8°C). Read voltage after fifteen (15) seconds with the load connected. Remove load. Estimate or measure the battery temperature and compare voltage reading with the voltage chart (see Figure 14). If the voltage is less than the minimum specified, replace the battery. If the voltage meets or exceeds the specified minimum, return the battery to service.

# BATTERY SYSTEM — BATTERY TESTING CHART

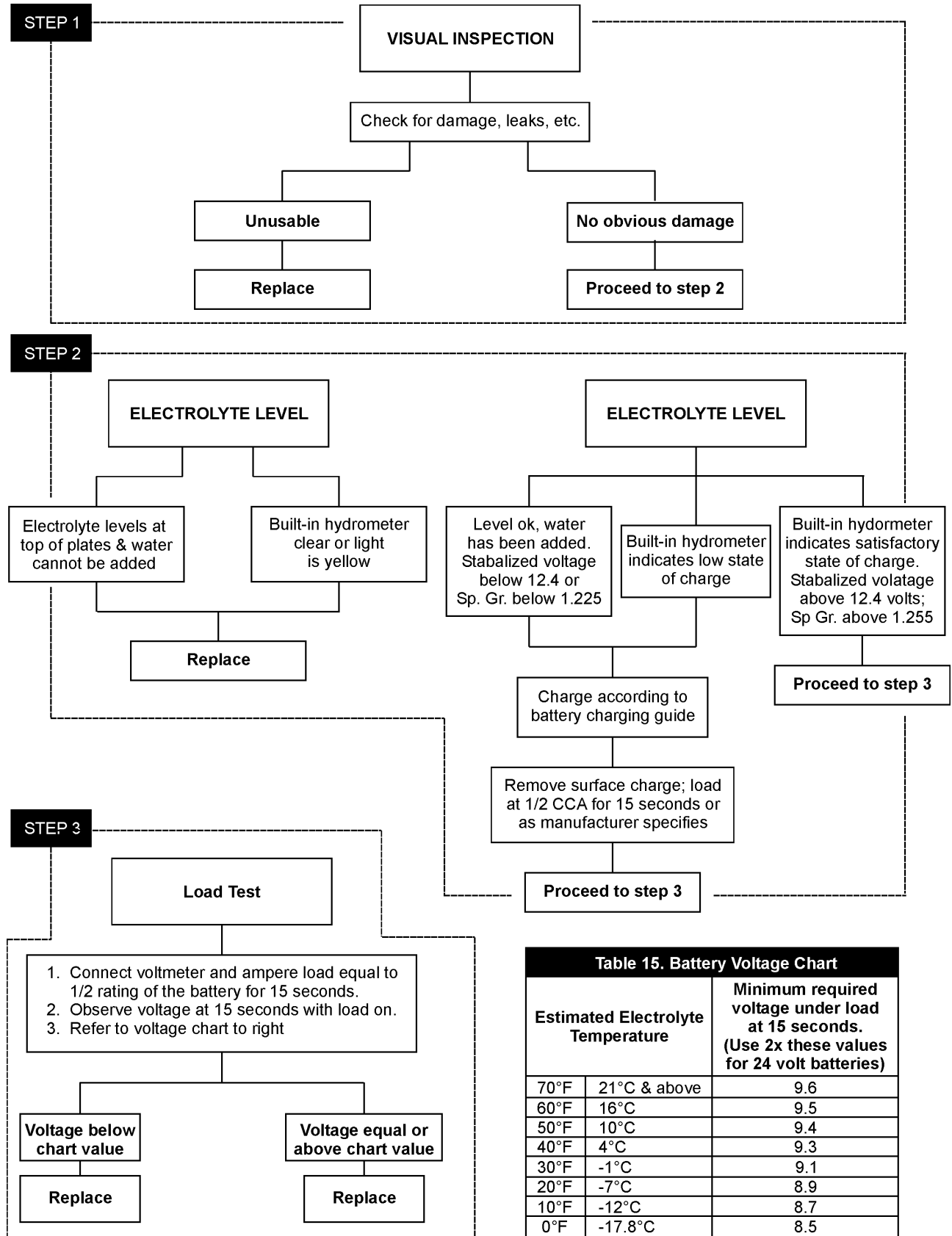

**Table 15. Battery Voltage Chart**

Estimated Electrolyte Temperature		Minimum required voltage under load at 15 seconds. (Use 2x these values for 24 volt batteries)
70°F	21°C & above	9.6
60°F	16°C	9.5
50°F	10°C	9.4
40°F	4°C	9.3
30°F	-1°C	9.1
20°F	-7°C	8.9
10°F	-12°C	8.7
0°F	-17.8°C	8.5

Figure 15. Battery Testing Chart

## BATTERY SYSTEM — CHARGING BATTERY

### Charging Low Water-loss Batteries

Before charging the battery, refer to page 9 for *battery safety instructions*.

Do not allow untrained personnel charge a battery until they have been thoroughly instructed in the step-by-step procedures of charging and all safety precautions.

Battery chargers operate automatically or should include a charge duration control of some type. This control is a timer which the operator sets.

Follow the manufacturer's instructions on the charger. If, when charging the battery, violent gassing or spewing of electrolyte occurs, or the battery case feels hot (125°F/52°C), halt charging to avoid damaging the battery.

Always turn the charger to the "Off" position (if not automatic) before connecting the leads to the battery. If there is any doubt about the charger being off, disconnect the charger from the power source.

If the battery does not indicate it is charged after the proper amount of charge time recommended, the charge should be repeated. If the battery is still uncharged after two charges, the battery should be replaced.

For best results, batteries should be charged while the electrolyte is at room temperature (55-85°F/13-30°C). A battery that is extremely cold or has remained in a completely discharged condition may not accept current for several hours after starting the charger.

Since age, capacity, state of charge, and type of batteries vary, *time* and *attention* must be given to batteries during any charging process.

If a battery is to be recharged overnight (16 hours), a timer or voltage controlled (16.0 volts) charger is recommended. If the charger does not have such controls, a 3 amp rate should be used for batteries of 80 minutes or less reserve capacity, and 5 amps for batteries with 80 to 125 minutes reserve capacity. Batteries over 125 reserve minutes should be charged at the specified slow charge rate.

### Battery Storage

Low water-loss batteries have excellent shelf life due to their low self-discharge rates. One of their major advantages is they normally can be installed without charging if good stock rotation and inventory controls are maintained.

The batteries must be kept in an upright position. It is possible for electrolyte to escape through the vents if the batteries are turned on their sides or top. Batteries should be stored in a cool, dry place. Storage above 80°F (26.7°C) increases self-discharge. If batteries are discharged, the electrolyte may freeze when stored below 20°F (-7°C). It is advantageous to store fully charged batteries at low temperatures, because the self-discharge rate drops as the temperature decreases.

Batteries in stock should be recharged when the open circuit voltage falls to 12.2 volts or when indicated by the built-in hydrometer as specified by the manufacturer.

# BATTERY SYSTEM — BATTERY CHARGER

## Battery Charger Introduction

The following section will cover the optional battery chargers offered for Industrial Generators with 12 or 24 Volt systems.

MQ Power battery chargers offer accurate, completely automatic charging of lead-acid and nickel-cadmium batteries. The battery charger's output voltage automatically adjusts to changing input, load, battery and ambient conditions. The result is fast battery charging without overcharging and consequent loss of battery electrolyte.

Standard features include AC line compensation, precision voltage regulation, current limiting, automatic dual-rate charging, ammeter and temperature compensation.

## Auto Boost Feature

After a battery has been discharged or when AC power is restored following a power failure, the charger operates in the high-rate constant current mode until the battery voltage rises to the preset boost level. Once this boost level is reached, the charger operates in constant voltage boost mode until the battery's current acceptance falls to less than 70% of the charger's rated output. The charger then reverts to the lower float voltage, where it operates until another battery discharge or AC failure occurs.

## Temperature Compensation

All batteries have a negative temperature coefficient. The battery charger is equipped with temperature compensation to assure correct charging in all conditions. Float voltage increases slightly as ambient temperature decreases, and decrease as ambient temperature increases.

## Current Limiting & Overload Protection

The charger is electronically current limited. When the charger is operating into a fully discharged battery, or is otherwise overloaded, charging voltage reduces so that the charger's rated output power in watts is not exceeded. The charger will operate satisfactorily into a short circuit indefinitely. In addition, AC and DC fuses are used for overload protection.

## Indicators and Adjustments

The battery charger has a 2.5" scale DC ammeter located on the outside of the battery charger aluminum enclosure. There is also an internal adjustment for float voltage. This also adjusts the boost voltage which is set at 5% higher than the float voltage.

## Operation

Apply AC power to the charger (Figure 16). Charger should start immediately. The charger will automatically recharge and maintain the battery with no further attention from the user.

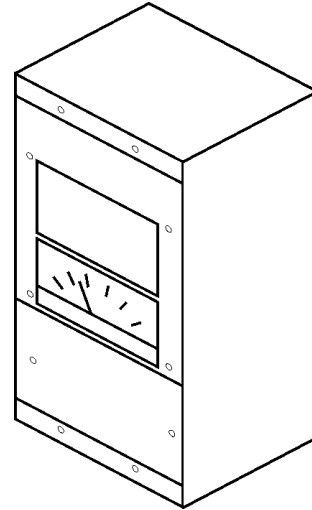

Figure 16. LC Battery Charger

Table 16. System Battery Specifications

Input Voltage	115VAC $\pm$ 10%
Input Frequency	57-63Hz
Output Voltage	12 or 24VDC (nominal)
Float Voltage	Adjustable
Boost Voltage	5% Above Float Voltage
Maximum Output Current	3.0 Amps
Output Voltage Regulation	$\pm$ 1%
Operating Temperature Range	-10°C to 50°C
Humidity Range	5% to 95% Non-condensing
Housing	Clear Anodized Aluminum

Table 17. Standard Factory Volt Setting

Float (12V — 24V)	13.3 — 26.6
Boost (12V — 24V)	14.0 — 28.0

# BATTERY SYSTEM — BATTERY CHARGER

## FC & FCA Battery Charger

In addition to the LC battery charger, a variation of full featured battery chargers are offered. The FC & FCA battery chargers have all of the standard features previously listed, and also include the following:

- Comprehensive alarm system that meets NFPA requirements.
- Soft start that ensures smooth start-up.
- AC & DC breakers (20 & 25 amp units).
- DC voltmeter.
- Separate internal adjustment for float & boost voltages.
- Separate internal adjustment for low and high DC alarms.
- Alarm indicators and remote contacts.
- Output Voltage increases to 10 Amps.

All battery chargers are unfiltered and are UL listed with the standard 120 input voltage. See the following paragraphs for details on each battery charger for 12 (or 24) volt systems.

## LC12(24)-500-2 Battery Charger

This is the most basic battery charger model. It provides 12 (24) VDC at 3.0 amps, 120 VAC 60 Hz single phase, automatic dual rate, temperature compensated, and no alarms.

## FC12(24)-10-2011U Battery Charger

This battery charger provides more output current than the basic charger. It provides 12 (24) VDC 10 amp, 120 VAC 60 Hz single phase, automatic dual rate, temperature compensated, and no alarms.

## FCA12(24)-10-2411U Battery Charger

This is a full featured battery charger. It provides 12 (24) VDC 10 amp, 120 VAC 60 Hz single phase, automatic dual rate, and is temperature compensated. In addition, it contains the following alarms:

- AC On LED
- AC Fail LED & Form C contact
- Charger Fail LED & Form C contact
- Low Battery Voltage LED & Form C contact
- High Battery Voltage LED & Form C contact

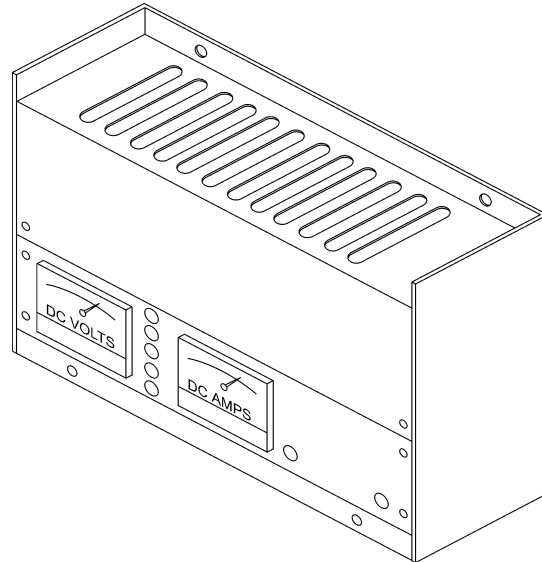

Figure 17. FC/FCA Battery Charger

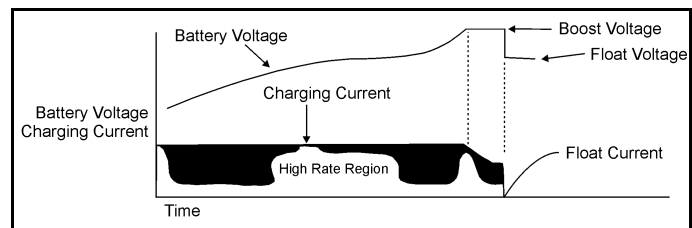

Figure 18. Charging Current Graph

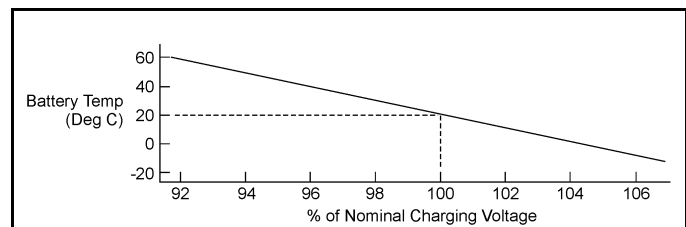

Figure 19. Temperature Compensation Graph

# BATTERY SYSTEM — BATTERY CHARGER SAFETY

## Battery Charger Installation

All work should be completed by qualified persons familiar with the installation, construction and operation of generator sets. All work should be completed in accordance with the National Electric Code (NEC), Uniform Building Code (UBC) and other state or local codes.

If the battery charger installation is to be completed on-site, consider the following recommendations:

1. Select a suitable mounting location for the battery charger. If indoors, the charger can be installed in a NEMA 1 or NEMA 2 enclosure. If outdoors, the charger must be installed in a NEMA 3R, outdoor enclosure.
2. Mount the battery charger as close to the engine starting batteries as possible.
3. If the battery charger is to be generator set mounted, the charger should be shock mounted to reduce engine vibration. Failure to do so could cause premature battery charger failure.
4. Verify the correct operational voltage for the charger and ensure the feeder providing power to the charger is protected by an appropriately sized, UL approved, circuit protection device.
5. All wiring and conduits should be sized and installed per NEC requirements.
6. AC voltage input terminations should match the voltage requirements of the battery charger. Ensure the DC output voltage of the charger matches the battery charging system of the engine-generator set.
7. Final DC wire terminations can be made by fitting the battery charger B+ (positive) to the B+ (positive) terminal on the engine electric starter mechanism. The battery charger ground (negative) should be fitted to the same lug where the engine starting battery ground cable is routed.
8. Secure all final battery charger connections (AC and DC) prior to energizing the circuit protection device feeding AC power to the charger.
9. Energize AC power and check the battery charger for proper operation.



## WARNING

Always be sure that the ground terminal provided on the battery charger is connected to a grounded wiring system.

## Battery Charger Safety

The following safety precautions should always be used with MQ Power battery chargers.

- **DO NOT** operate if battery charger is dropped or otherwise damaged.
- **DO NOT** expose charger to rain or snow.
- **DO NOT** disassemble charger. Return to factory for service and repairs. Incorrect assembly may result in a risk of electric shock or fire.
- **ALWAYS** de-energize and disconnect the AC input and the battery from the charger if contact with the battery charger is necessary. Failure to do so may result in electric shock.
- During normal operation, batteries may produce explosive hydrogen gas. **NEVER** smoke, use an open flame, or create sparks near the battery or charger.



## WARNING

Changing the factory-set potentiometer voids the warranty. Contact the factory if the setting on the charger is incorrect.

If the charger is not working correctly, first check the following:

1. Is AC power available to the charger?
2. Is the charger connected to a battery of the correct voltage? (The charger must be connected to a battery for it to operate at the correct voltage.)
3. Is the charger damaged? (Check for debris, particularly metal, inside the charger enclosure.)
4. If the charger appears not to be working check the battery's state of charge. If the battery is fully charged it is sometimes normal for the charger to indicate zero current flow. Also check the battery for shorted or open cells.
5. If the battery is being overcharged or undercharged, check whether the output voltage settings have been tampered with. The potentiometers should be covered with either white adhesive paper dots or a hard red varnish.
6. If charger is still not working properly, call the factory for assistance.

# MECHANICAL INSTALLATION — VENTILATION AND COOLING

## Engine Cooling

Liquid-cooled engines are cooled by pumping coolant ( a mixture of water and antifreeze) through passages in the engine cylinder block and heads by means of an engine-driven pump. The engine, pump, and radiator (or liquid-to-liquid heat exchanger) form a closed-loop, pressurized cooling system. The most common genset configuration has a mounted radiator and engine-driven fan to cool the coolant and ventilate the generator room. Alternate methods for cooling the coolant include a mounted liquid to liquid heat exchanger, a remote radiator, or a remote liquid-to-liquid heat exchanger. These alternate methods are covered later in this section.

## Ventilation and Cooling

Generator Sets create considerable heat that must be removed by proper ventilation. Outdoor installations rely on natural air circulation but indoor installations need properly sized and positioned vents for adequate air flow.

## Vents and Ducts

For indoor installations, locate vents so incoming air passes through the immediate area of the installation before exhausting. Install the air outlet higher than the air inlet to allow for convection air movement.

Size the vents and ducts (Figure 21) so they are large enough to allow the required flow rate of air. The "free area" of ducts must be as large as the exposed area of the radiator.

Wind will restrict free airflow if it blows directly into the air outlet vent. If possible, locate the outlet vent so the effects of wind are eliminated. See Figure 20.

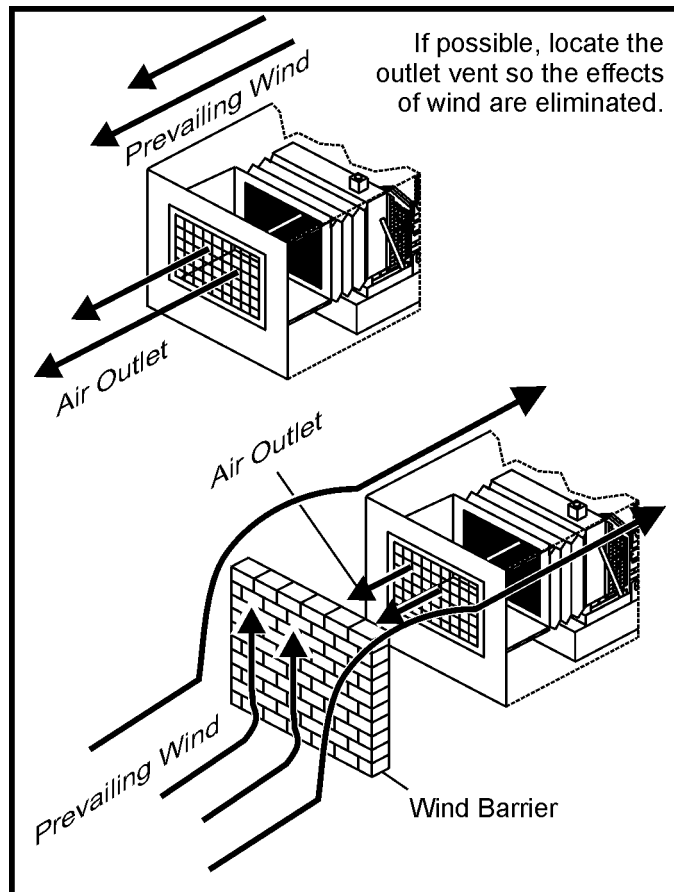

Figure 20. Wind Barrier

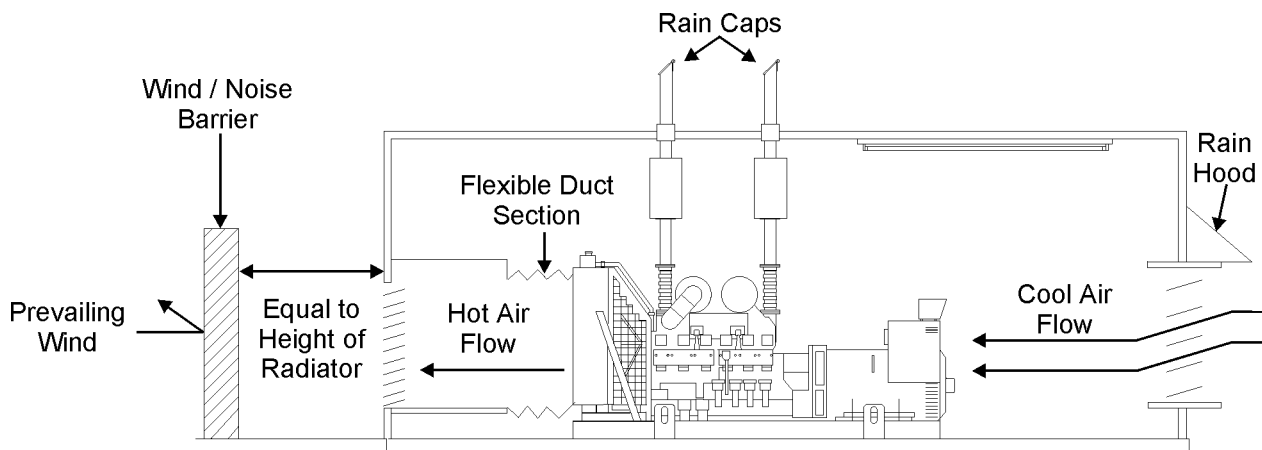

Figure 21. Wind Barrier Installation

## MECHANICAL INSTALLATION — VENTILATION AND COOLING

For outdoor installations, weather and silenced housings are available for the industrial generator. Housed industrial units typically do not use ventilation louvers. However, louvers are another ventilation option and can be found on MQ Power Studio generators and will be referenced in this manual for information purposes.

### **Louvers**

Louvers are automatic ventilation doors that open when the engine engages and close while not in use. Louvers protect the genset and equipment room from the outside environment. Their operation of opening and closing should be controlled by operation of the genset.

In cooler climates movable or discharge louvers are used. These louvers allow the air to be recirculated back to the equipment room. This enables the equipment room to be heated while the genset engine is still cold, increasing the engine efficiency.

## MECHANICAL INSTALLATION — MOUNTED RADIATOR COOLING

### Factory Mounted Radiator Ventilation

Ventilation of the generator set is necessary to remove the heat and fumes dissipated by the engine, generator, battery, and its accessories as well as provide combustion air.

When the genset has a factory mounted radiator (Figure 22), the fan draws air over the set and pushes it through the radiator which has flanges for connecting a duct to the outdoors.

Consider the following when installing a factory mounted radiator genset:

- See the genset specification sheet for the design airflow through the radiator, allowable airflow restriction, and minimum air inlet and outlet opening areas. *The allowable air flow restriction must not be exceeded.* The static pressure (air flow restriction) should be measured to make sure the system is not too restrictive, especially when ventilating air is supplied and discharged through ducts, restrictive grilles, screens, and louvers.
- Refer to the ASHRAE (American Society of Heating, Refrigeration and Air Conditioning Engineers) publications for recommendations on duct design if air ducts are required. Note that the inlet duct must handle combustion air flow, ventilating air flow, and must be sized accordingly.
- Louvers and screens over air inlet and outlet openings restrict air flow and vary widely in performance. A louver assembly with narrow vanes, for example, tends to be more restrictive than one with wide vanes. The effective open area specified by the louver or screen manufacturer should be used.

- The airflow through the radiator is usually sufficient for generator room ventilation.
- The radiator fan will cause a slight negative pressure in the room. Therefore it is recommended that combustion equipment such as the building heating boilers not be located in the same room as the genset. If this is unavoidable, it is necessary to determine if there will be detrimental effects, such as backdraft. If so, means such as extra large room inlet openings and/or ducts, pressurized fans, etc. may be required to reduce the negative pressure to acceptable levels.
- Other than recirculating radiator discharge air into the generator room in colder climates, all ventilating air must be discharged directly to the outdoors. It must not be used to heat any space other than the generator room.
- A flexible duct connector must be provided at the radiator to take up genset movement, vibration, and transmission of noise.
- Ventilating air inlet and discharge openings should be located or shielded to minimize fan noise and the effects of wind on airflow.

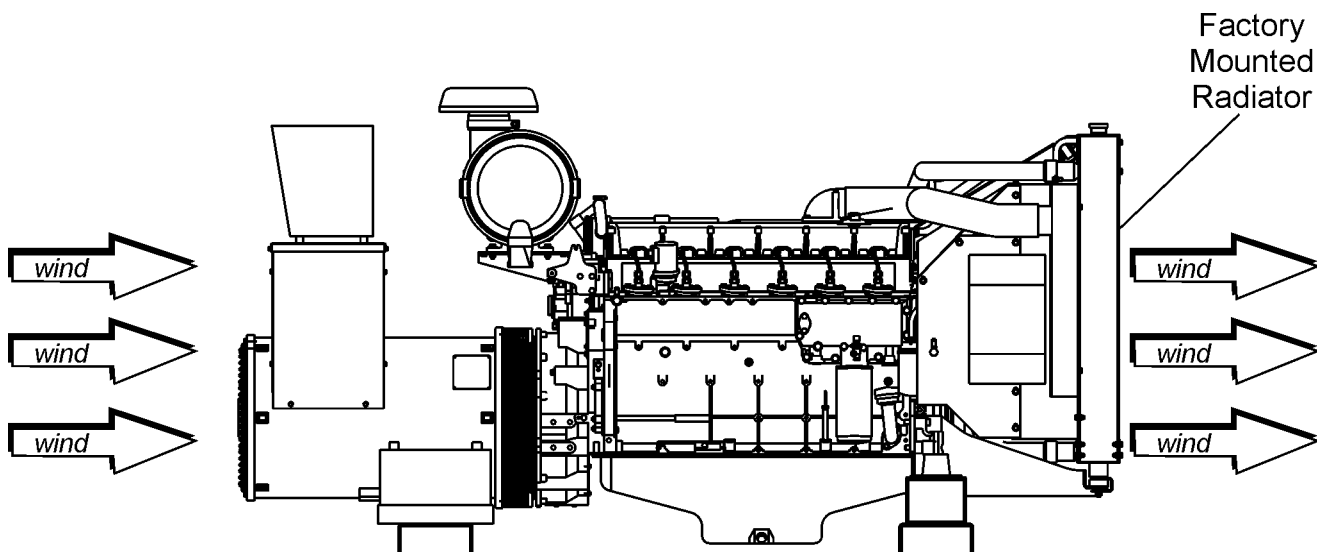

Figure 20. Factory Mounted Radiator

# MECHANICAL INSTALLATION — MOUNTED RADIATOR COOLING

## Mounted Radiator Cooling System

A generator set with a factory-mounted radiator is an integral cooling and ventilating system. This is the recommended configuration involving the least amount of auxiliary equipment, piping, control wiring, and coolant.

Mounted radiator cooling system uses a set mounted radiator and engine pusher fan to cool engine water. Air travels from the generator end of the set, across the engine, and out through the radiator. An integral discharge duct adapter flange surrounds the radiator grill.

A primary consideration for mounted radiator installations is the necessity of moving large quantities of air through the generator room.

## Radiator Set Requirements

Radiator set cooling air is drawn past the rear of the set by a pusher fan that blows air through the radiator (See Figure 23). Locate the air inlet to the rear of the genset. Make the inlet vent opening 1-1/2 to 2 times larger than the radiator area to ensure proper cooling.

Locate the cooling air outlet (as close as possible) directly in front of the radiator. The outlet opening must be at least as large as the radiator area. Length and shape of the air outlet duct should offer minimum restriction to airflow.

The radiator has an air discharge duct adapter flange. Attach a canvas or sheet metal duct to the flange and the air outlet opening using screws and nuts so duct can be removed for maintenance purposes. The duct prevents circulation of heated air. Before installing the duct, remove the radiator core guard.

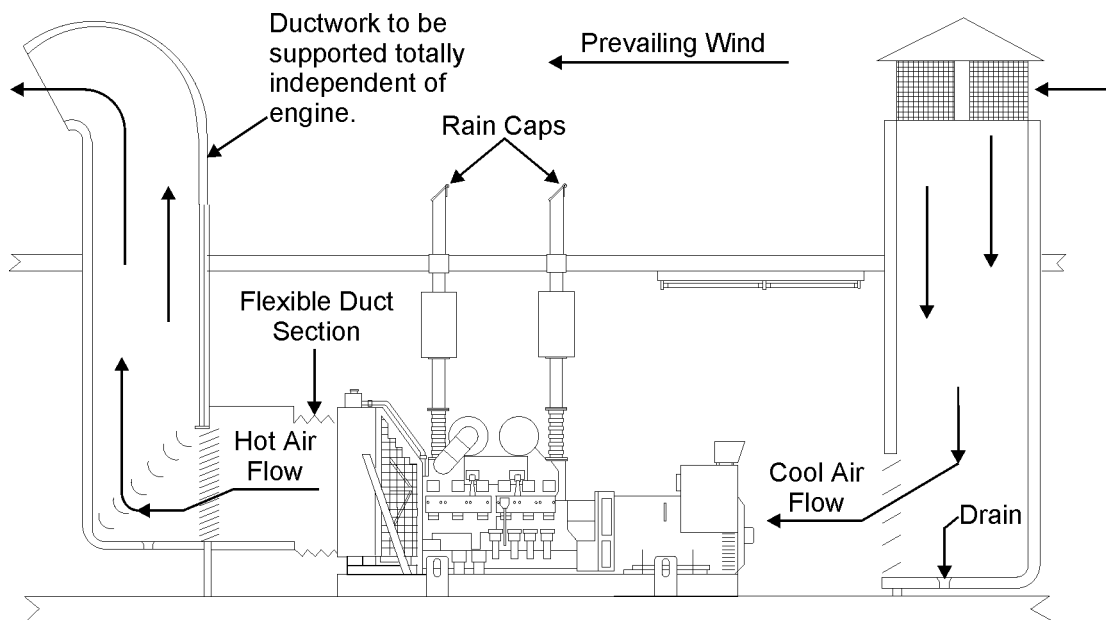

Figure 21. Duct Air Installation

## MECHANICAL INSTALLATION — REMOTE RADIATOR COOLING

### Remote Radiator Cooling (optional)

Remote radiator cooling substitutes a remote mounted radiator and an electrically driven fan for the set mounted components (see Figure 24). Removal of the radiator and the fan from the set reduces noise levels without forcing dependence on a continuous cooling water supply. The remote radiator installation must be completely protected against freezing conditions.

Application of a remote radiator to cool the engine requires proper design. Consider the following:

- It is recommended that the radiator and fan be sized on the basis of a maximum radiator top tank temperature of 200°F (93°C) and a 115% cooling capacity to allow for fouling. Refer to the *heat rejected to coolant* and *coolant flow rate* specifications for radiator sizing.
  - The capacity of the radiator top tank or auxiliary tank must be equivalent to at least 15% of the total volume of coolant in the system to provide a coolant "drawdown capacity" (10%) and space for thermal expansion (5%). Drawdown capacity is the volume of coolant that can be lost by slow, undetected leaks and the normal relieving of the pressure cap before air is drawn into the coolant pump. Space for thermal expansion is created by the fill neck when a cold system is being filled.
  - To reduce radiator fin fouling, radiators have a more open fin spacing (nine fins or less per inch) should be considered for dirty environments.
  - Coolant friction head external to the engine (pressure loss due to pipe, fitting, and radiator friction) and coolant static head (height of liquid column measured from crankshaft center line) must not exceed the maximum allowable values on the genset specification sheet.
- Radiator hose 6 to 18 inches (152 to 457 mm) long, complying with SAE 20R1, or equivalent standards, should be used to connect coolant piping to the engine to absorb genset movement and vibration.
  - It is highly recommended that the radiator hoses be clamped with two premium grade "constant-torque" hose clamps at each end to reduce the risk of sudden loss of engine coolant due to a hose slipping off from being under pressure. *Major damage can occur to an engine if it is run without coolant in the block.*
  - A coolant drain valve should be located at the lowest part of the system.
  - Depending on the amount of coolant in the system, ball or gate valves are recommended. Globe valves are too restrictive. This will isolate the engine so the entire system does not have to be drained before servicing the engine.
  - To obtain the *net power* available from the genset, add the fan load indicated on the genset specification sheet to the power rating of the set and subtract the power consumed by the remote radiator fan, ventilating fans, coolant pumps, and other accessories required for the genset to run.

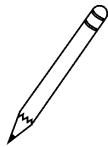
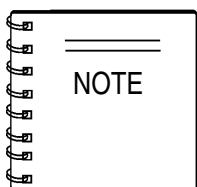

Excessive coolant static head (pressure) can cause the coolant pump shaft seal to leak.

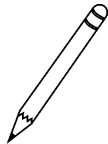
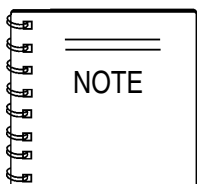

Excessive coolant friction head (pressure loss) will result in insufficient engine cooling.

# MECHANICAL INSTALLATION — REMOTE RADIATOR COOLING

## Remote Radiator Cooling

Figure 24 below shows a typical installation of a remote radiator type cooling system.

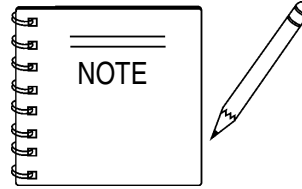

The coolant flow is provided by the engine mounted pump

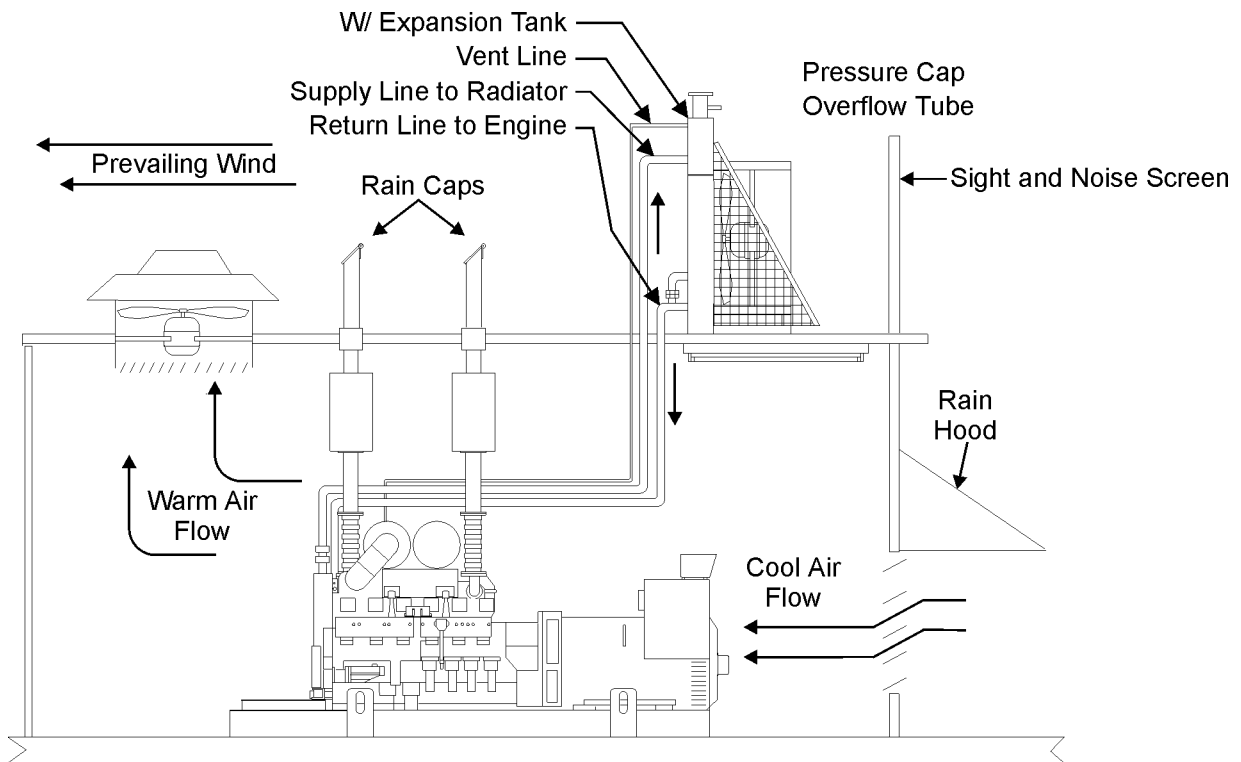

Figure 24. Remote Radiator Installation

# MECHANICAL INSTALLATION — HOTWELL COOLING

## Hot Well Installation

Figure 25 below shows a typical installation of a remote radiator with a hot well cooling system.

A remote radiator with a hot well can be used if the elevation of the radiator above the crankshaft center line exceeds the allowable coolant static head on the genset. Refer to the generator specification sheet. In a hot well system, the engine coolant pump circulates coolant between engine and hot well and an auxiliary pump circulates coolant between hot well and radiator. A hot well system requires a careful design and proper installation. In addition to the considerations under the remote radiator, consider the following:

- The bottom of the hot well should be above the engine coolant outlet.
- Coolant flow through the hot well / radiator circuit should be approximately the same as coolant flow through the engine. The radiator and the auxiliary pump must be sized accordingly. The pump head must be sufficient enough to overcome the sum of the static and friction heads in the hot well / radiator circuit. *One foot of pump head is equivalent to 0.43 PSI of coolant friction head (pressure loss) or one foot of coolant static head (height of liquid column).*
- The liquid holding capacity of the hot well should not be less than the sum of the following volumes:
  - 1/4 of the coolant volume pumped per minute through the engine (e.g., 25 gallons if the flow is 100 gpm), plus
  - 1/4 of the coolant volume pumped per minute through the radiator (e.g., 25 gallons if the flow is 100 gpm), plus
  - Volume required to fill the radiator and piping, plus
  - Five percent (5%) of the total system volume

- Careful design of the inlet and outlet connections and baffles is required to minimize coolant turbulence and maximize blending of engine and radiator coolant flows.
- Coolant must be pumped to the bottom tank of the radiator and returned from the top tank, otherwise the pump will not be able to completely fill the radiator.
- The auxiliary pump must be lower than the low level of coolant in the hot well so it is always primed.
- The radiator should have a vacuum relief check valve to allow drain down to the hot well.
- The hot well should have a high volume breather cap to allow the coolant level to fall as the auxiliary pump fills the radiator and piping.
- To obtain the *net power* available from the genset, add the fan load indicated on the genset specification sheet to the power rating of the set and subtract the power consumed by the remote radiator fan, ventilating fans, coolant pumps, and other accessories required for the genset to run.

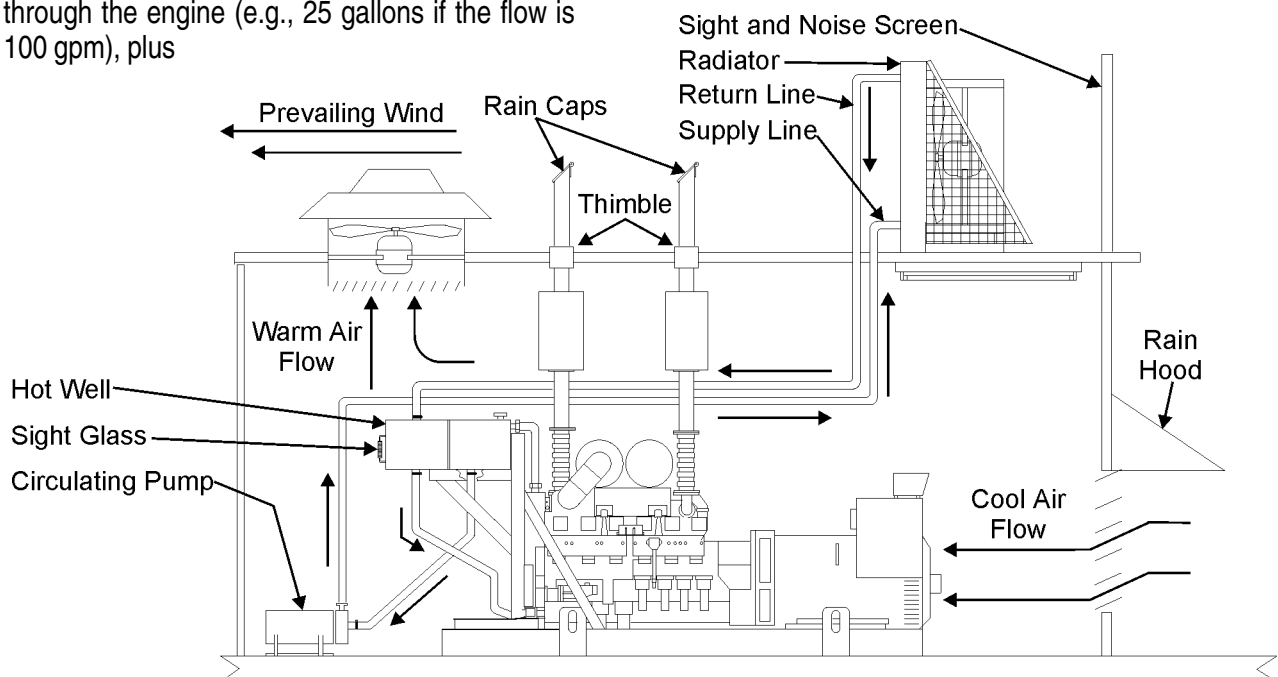

Figure 25. Hot Well Installation

# MECHANICAL INSTALLATION — HEAT EXCHANGER COOLING

## Heat Exchanger

A heat exchanger installation uses a shell and tube type heat exchanger instead of the standard radiator and fan (see Figure 26). Engine jacket and coolant circulates through the shell side of the two heat exchangers while the cooling water is pumped through the tubes. Engine coolant and raw water do not mix. This type of cooling separation is necessary because raw water can contain scale forming lime or other impurities.

This system can reduce set enclosure airflow requirements and noise levels. Proper operation depends on a constant supply of raw water for heat removal. Adjust the flow to maintain the proper engine jacket water coolant temperature and the coolant temperature. The engine coolant side of the system can be protected from freezing; the raw water side cannot be protected.

The engine, pump, and liquid-to-liquid heat exchanger form a closed, pressurized cooling system. The engine coolant and raw cooling water do not mix. Consider the following:

- The installation will require a powered ventilating system.
- To obtain the net power available from the genset, add the fan load indicated on the specification sheet to the power rating of the set and subtract the power consumed by the remote radiator fan, ventilating fans, coolant pumps, and other accessories required for the genset to run.

- A pressure reducing valve must be provided if water source pressure exceeds the heat exchanger pressure rating.
- The heat exchanger and water piping must be protected from freezing if the ambient temperature can fall below 32°F (0°C).
- A thermostatic water valve (nonelectric) is recommended to modulate water flow in response to coolant temperature and normally closed battery powered shut-off valve to shut off the water when the set is not being used. (Always leave water on if a standby application)
- There must be sufficient raw water flow to remove the heat rejected to coolant indicated on the specification sheet. Note that a gallon of water absorbs approximately 8 BTU each 1°F rise in temperature (specific heat). Also, it is recommended that the raw water leaving the heat exchanger not exceed 140°F (60°C). Use the following formula:

$$\text{Raw Water Required (gpm)} = \frac{\text{Heat Rejected } \left( \frac{\text{Btu}}{\text{min}} \right)}{\text{Temp Rise } (\Delta^{\circ}\text{F}) \times \text{Specific Heat } \left( \frac{8 \text{ Btu}}{^{\circ}\text{F-Gallon}} \right)}$$

If a set rejects 19,200 Btu per minute and the raw water inlet temperature is 80°F, the raw water required is:  
 $[19,200 / (60 \times 8)] = 40 \text{ gpm}$

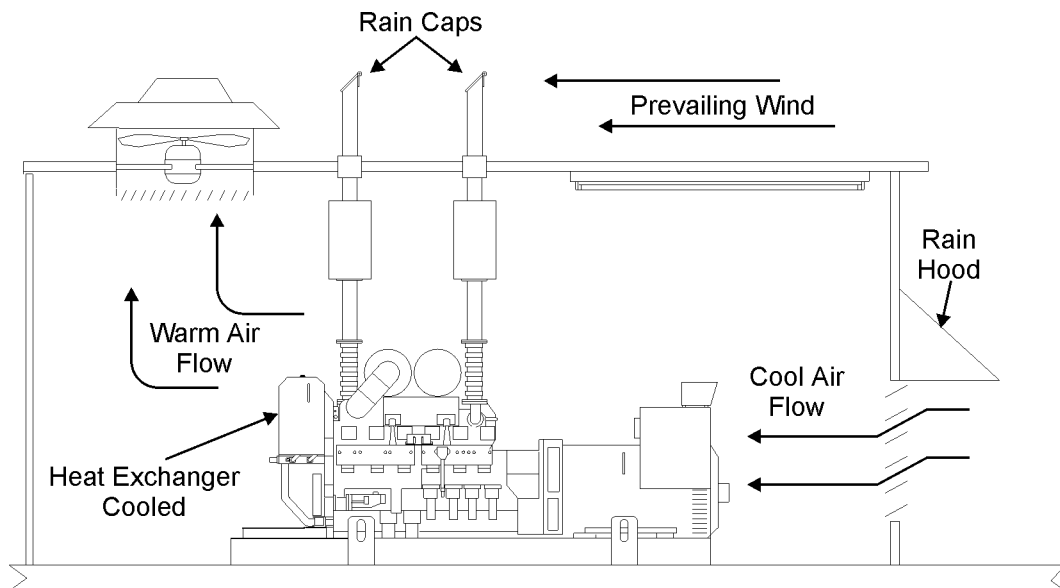

Figure 26. Heat Exchanger Installation

## Coolant Treatment

Antifreeze (ethylene or propylene glycol base) and water are mixed to lower the freezing point of the cooling system and to raise the boiling point. Refer to Table 18 to determine the concentration ethylene or propylene glycol necessary for protection against the coldest ambient expected. Antifreeze/water mixture percentages in the range of 30/70 to 60/40 are recommended for most applications.

Propylene glycol based antifreeze is less toxic than ethylene based antifreeze, offers superior liner protection, and eliminates some fluid spillage and disposal reporting requirements.

Replaceable coolant filters and treating elements minimize coolant system fouling and corrosion. They are compatible with most antifreeze formulations.

## Coolant Heaters

An optional water jacket heater can be installed to keep the engine warm for starting under adverse weather conditions. Thermostatically controlled engine coolant heaters are usually recommended to accurately control coolant temperature. For Level 1 emergency power systems, NFPA 110 requires that engine coolant be kept at a minimum 90°F (32°C).

Connect the heater to a power source that will be on when the engine is NOT running (such as commercial power or other independent powers source).

**Table 18. Freezing and Boiling Points Vs. Concentration of Antifreeze**

Mixture Base		Mixture Percentages (Antifreeze/Water)					
		0/100	30/70	40/60	50/50	60/40	95/5
Ethylene Glycol	Freezing Point	32°F (0°C)	4°F (-16°C)	-10°F (-23°C)	-34°F (-36°C)	-65°F (-54°C)	8°F (-13°C)
	Boiling Point	212°F (100°C)	220°F (104°C)	222°F (106°C)	226°F (108°C)	230°F (110°C)	345°F (174°C)
Propylene Glycol	Freezing Point	32°F (0°C)	10°F (-12°C)	-6°F (-21°C)	-27°F (-33°C)	-56°F (-49°C)	-70°F (-57°C)
	Boiling Point	212°F (100°C)	216°F (102°C)	219°F (104°C)	222°F (106°C)	225°F (107°C)	320°F (160°C)

# ELECTRICAL INSTALLATION — DC CONTROL WIRING

## Control Wiring

The genset control box, which is located on top of the alternator housing, contains connection points for remote control and monitor options (see Figure 27 below). These connection points are located on the terminal block within the electronics box.

### CAUTION

Stranded copper wire must be used for all customer connections to the electronics box. Solid copper wire may break due to vibration.

## Remote Control / Monitor Connections

Customer remote control / monitor connections are attached to terminal block TB1. Optional equipment such as a remote annunciator panel, sensing devices used to monitor genset operation, remote start/stop switches, etc. are attached to this terminal block. Driver signals for customer supplied relays are also provided for several alarm and shutdown conditions.

### CAUTION

When making connections to TB1 for customer control / monitor control functions, be sure the battery power is disconnected from the terminal block by removing the 5 amp control power fuse.

## Terminal Block Wiring

Due to the wide variety of devices that can be attached to the relay outputs of terminal blocks, the electrical contractor must determine the gauge of *stranded copper* wire that is to be used at the relay connections.

## Switched B+

Fused at 20 amps. See relay connection description.

## Digital Connections

Digital connections to the genset controller should be terminated directly to the controller with the following requirements:

- 18 gauge twisted pair cable with an overall shield
- Overall cable should include the number of twisted pairs as indicated on the customer connection diagram
- Network cable **SHOULD NOT** be run in the same conduit as the AC power output conductors
- Length should be 1000 feet maximum

### CAUTION

Always run control circuit wiring in a separate metal conduit from AC power cables to avoid inducing currents that could cause problems within the control circuits

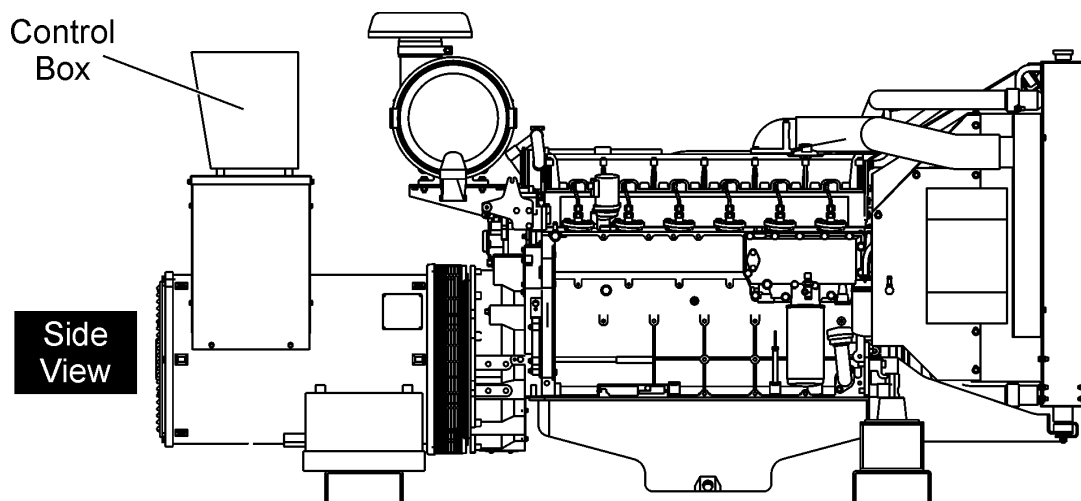

Figure 27. Control Box Location

# DC CONTROL WIRING — CONTROL BOX BACK PANEL

## Control Box

The control box contains the following:

### ■ Digital Control Module

There are two available digital control modules available for industrial generator sets:

- ICS-30™
- ICS-50™

Reference your supplied digital control manual for detailed information.

### ■ Control Box Back Panel Components

The Control Box back panel is shown in Figure 28 and contains the following components:

- Standard Electronic Governor
- TB1 Terminal Block
- Control Relays
- Fuses

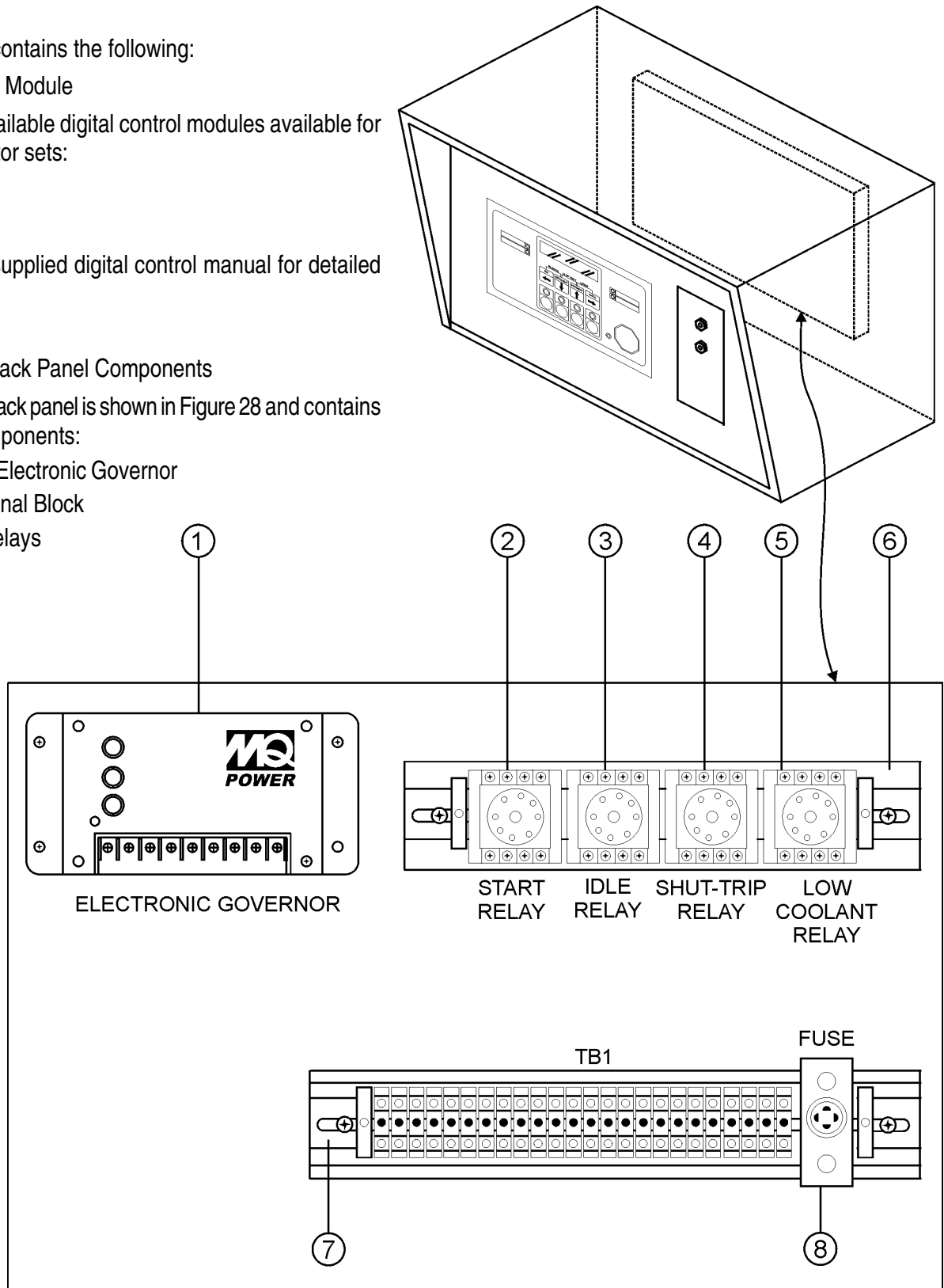

Figure 28. Inner Control Box Panel

## DC CONTROL WIRING — CONTROL BOX BACK PANEL

The definitions below describe the components of the "Control Box" back panel (Figure 26).

1. **Electronic Governor (Standard)** – This electronic speed control exhibits fast and precise response to transient load changes. When used in conjunction with a proportional electric actuator, the governor offers closed loop governing.

Either isochronous or droop governing modes can be selected. The engine's idle speed is variable and selected by a simple switch closure. Engine exhaust smoke during start-up can be minimized when the starting fuel adjustment is optimally set.

2. **Start Relay (K2)** – This relay interfaces with the engine (75-150kW) and electronic governor controller (if present) for start and stop functions of the generator.

3. **Idle Relay (K4)** – This optional relay is installed to interface with the voltage regulator sensing circuits when the optional idle switch is used.

4. **Shunt Trip Relay (K5)** – This relay optional relay is installed to trip the main output circuit breaker under fault conditions. This circuit can be wired to the genset controller to trip the breaker or a shutdown condition.

This relay can also be wired to an external (customer supplied) circuit for external trip control of the breaker.

5. **Low Coolant Level Relay (K3)** – This relay is installed to interface with the low coolant level switch to the genset controller.

6. **Relay DIN Rail** – This rail holds all the relays used for DC controls.

7. **Terminal Block One (TB1)** – This terminal block is used for DC control wiring. See the generator set wire diagram for details.

8. **Control Power Fuse** – This fuse protects terminal block one (TB1) from overcurrent. Remove this fuse when servicing TB1.

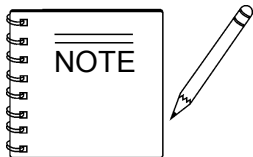

The control box back panel can vary between models depending on customer specifications and DC controls used.

# AC ELECTRICAL CONNECTIONS

## Overview

This section provides the procedure that is used to connect the AC electrical system of the Industrial generator set.

As with all servicing, disconnect the battery charger and the battery cables (negative [-] first) to prevent accidental starting before working on unit.

### CAUTION

Always disconnect a battery charger from its AC source before disconnecting the battery cables. Failure to do so can result in voltage spikes high enough to damage the DC control circuits.

### DANGER

Accidental starting of the generator set while working on it can cause severe personal injury or even **death**. Prevent accidental starting by disconnecting the starting battery cables (negative [-] first).

### WARNING

Each of the operations described in this section should be done only by persons trained and experienced in electrical maintenance. Improper procedures may result in property damage, bodily injury, or even death.

### WARNING

Backfeed to a utility system can cause property damage, personal injury, or even **death**! **DO NOT** connect to any buildings electrical system except through an approved device and after the building main switch is opened. When connecting to a building's electrical system, always have a licensed electrician perform the installation.

Connecting the genset AC electrical system involves the following:

- Installation of a transfer switch (standby applications only)
- Generator voltage connections
- Load connections
- Standard and optional AC equipment connections (e.g. control box heater, coolant heater, etc.)

Local regulations often require that wiring connections be made by a licensed electrician, and that the installation be inspected and approved before operation. All connections, wire sizes, materials used, etc. must conform to the requirements of all electrical codes in effect at the installation site.

### DANGER

Improper wiring can cause a fire or electrocution, resulting in property damage, severe injury, or even **death**!

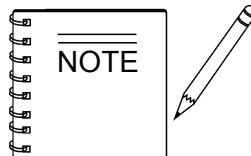

*Before starting the genset, verify that all electrical connections are secure, and that all wiring is complete. Replace and secure any access panels that have been removed during installation.*

*Check that the load cables from the genset are properly connected.*

## Transfer Switch

In a standby application, a transfer switch (Figure 29) must be used for switching the load from the normal power source to the genset. Either a manual or automatic transfer switch may be used. Follow the installation instructions provided with the transfer switch when connecting the load and control wiring. Only a licensed electrician should perform the installation of a transfer switch.

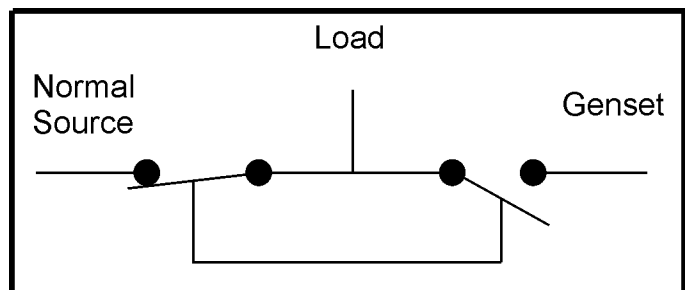

Figure 29. Typical Transfer Switch

## AC WIRING

### Generator Voltage Connections

The generator output voltage and maximum current rating are specified on the generator set nameplate. Line-to-neutral voltage is always the lower voltage shown and the line-to-line voltage is the higher rating.

The generators are available at the voltages shown in the wiring diagram of the genset. The genset is connected at the factory to produce a specified voltage per customer order.

Before shipping, the factory tests the generator set at the specified voltage. The generator may be connected at the factory to produce a specified voltage per customer order.

### Load Connections (Connecting the Load)

All loads are connected to the generator by bolting the *stranded* load wires to the appropriate terminals on the generator output circuit breaker. The terminals are marked for identification to indicate the line and neutral connections.

### Load Balancing

When connecting loads to the generator set, balance the loads so the current flow from each line terminal is about the same. This is especially important if both single phase and three phase loads are connected. ***Unbalanced loading of a genset causes unbalanced phase voltages.***

Any combination of 1Ø and 3Ø loading can be used as long as each line current is about the same, within 10% of the median value and no line current exceeds the nameplate rating of the generator. Check the current flow from each line after connections by observing the control panel ammeter.

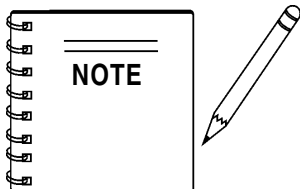

*Correct grounding in standby systems that are solidly grounded is a function of the transfer switch equipment used (solid neutral or switched neutral).*

## Grounding

The following is a brief description of system and equipment grounding of permanently installed AC generators within a facility wiring system. It is important to follow the requirements of the local and county electrical codes.

### System Grounding

System grounding is the intentional grounding of the neutral point of a wye-connected generator, the corner of a delta-connected generator, or the neutral point of one phase winding of a delta-connected generator, depending on the system voltage required in the application. It is common to ground the neutral point of a wye-connected generator and bring out the neutral (grounded circuit conductor) in a 3Ø four-wire system.

*A corner-grounded delta system has a grounded circuit conductor that is not a neutral and a "wild leg" that must be identified by orange color coding and connected to the middle pole of the 3Ø equipment.*

### System Grounding Methods

#### *Solid Grounding*

This method is typically used and required by the National Electrical Code (NEC) on all low voltage systems (600 volts and below) with a grounded circuit conductor (most often a neutral).

The system is grounded with a direct connection by a conductor (the grounding electrode conductor) with no intentional impedance to earth (grounding electrode).

#### *Ungrounded*

Ungrounded systems are special applications where no intention of connection is made between the AC generator system and earth. Occasionally used on 3Ø three-wire systems (no grounded circuit conductor) operating at 600 volts or below, where continuity of power with one ground fault is required or desirable, and qualified service electricians are on site. An example would be a critical process industry.

Emergency Standby Generator Systems (600 Volts and below)  
The National Electric Code (NEC) requires the engine-generator be provided with phase overcurrent protection such as fuses or circuit breakers. In some applications, ground fault protection may be also be required.

## Generator Main Line Circuit Breaker

- a) **Generator-Mounted Main Line Circuit Breaker (MCB)** - Industry practice is to provide a molded-case circuit breaker, sized to protect the generator feeder conductors against overcurrent, and provide provisions for a disconnecting means, to meet National Electric Code (NEC) requirements.
- b) **Neutral Conductors** – The ampacity of the neutral conductor is generally permitted to be equal to or greater than the calculated maximum single-phase unbalance of the load. Where a significant portion of the load is non-linear, the neutral conductor should be sized in accordance with anticipated neutral current but never less than 100 percent rated.

## Sizing A Generator Main Line Circuit Breaker

Sizing a generator main line circuit breaker is typically the result of electrical engineering review of generator load schedules and design calculations for a feeder and its overcurrent device, keeping in mind that the primary purpose of the generator main line circuit breaker is to protect the feeder conductors as per the National Electric Code (NEC).

MQ Power offers several factory-mounted circuit breaker options per model, based on generator output voltage and current ampacity. Unless specified otherwise, these circuit breakers, both thermal-magnetic and electronic trip types, are factory sized for the maximum output current of each engine-generator, with regards to their respective voltage connection. The circuit breakers are mounted on the engine-generator so as to meet code requirements which stipulate the overcurrent protective device be located within 25-feet of the generator output terminals.

It should be noted too, when sizing a main line circuit breaker, that feeder ampacity and overcurrent device ratings should be calculated by summing the total of load currents of all branch circuits being supplied by the engine-generator, multiplied by any applicable demand factors allowed by National Electric Code (NEC). In any event, the minimum size of the generator main line circuit breaker should be at least equal to the ampacity rating of the feeder conductors (or the next largest standard rating).

## Field Installing A Generator Main Line Circuit Breaker

All work should be completed by qualified persons familiar with the installation, construction and operation of generator sets. All work should be completed in accordance with the National Electric Code (NEC), Uniform Building Code (UBC) and other state or local codes.

### **WARNING**

**DO NOT** attempt to field install a main line circuit breaker while the engine-generator is capable of starting and running. Serious injury or death could result. Make sure the generator control is in the **OFF** position, then disconnect the engine starting battery by lifting the cables (ground cable first). It is advisable to use "Lock-Out" tags accordingly.

When installing a main line circuit breaker **NOT** factory supplied by MQ Power, it is code required that the circuit breaker be UL listed. The overcurrent protective device should be installed with the correct voltage, current and short-circuit interruption ratings that are appropriate for the generator output. The interrupting capacity of the circuit breaker must be equal to or greater than the amount of fault current that can be delivered at the point in the system where the circuit breaker is applied.

Once the circuit breaker has been properly sized and the appropriate cable and lugs have been determined, the circuit breaker should be mounted on the engine-generator in a suitable location. The circuit breaker should be mounted on the engine-generator so as to minimize vibrations produced by the engine while running.

## Connection Of Generator Leads For Correct Voltage Output

It is required of the installer to connect the generator main stator leads (12-lead generator) in a configuration required to meet the system voltage output requirement. Refer to the MQ Power reconnection diagram to review the various voltage connection configurations. Once the voltage selection and correct wiring configuration has been completed, the wiring is terminated at the circuit breaker input lugs and/or bus bar.

## Electrical Terminations

Most engine-generators, whether located indoor or outdoors are usually mounted on a concrete pad and typical electrical terminations are brought up underneath the engine-generator for final termination. This cable entry or “stub-up” underneath the generator set provides for easy termination of the feeder conductors and makes for a clean, professional looking installation. Check code compliance before proceeding.

- a) **Separately Mounted Fuel Tank** - When a separately mounted fuel tank is used, the electrical stub-up underneath the generator set is simplified because of the open bottom design of the generator skid. The final cable terminations rise from the stub-up entry location underneath the engine-generator, in a close proximity to the circuit breaker enclosure. When code required, these feeders should be provided in suitable and properly sized conduits that attach to the circuit breaker enclosure. The feeder cables then connect directly to the output lugs and/or bus bars provided on the main line circuit breaker.
  
- b) **Subbase Mounted Fuel Tank** - When a subbase fuel tank is used (refer to Fuel System section), the tank should be designed with a stub-up area on the generator-end of the tank. This feature allows for an open area on the tank assembly whereby electrical terminations can be brought up underneath the engine-generator for final termination, just like the open bottom design generator skid. (This feature is standard for all MQ Power subbase tanks and is typically a purchasable option from most tank manufacturers) When code required, the feeder conductors should be provided in suitable and properly sized conduits that attach to the circuit breaker enclosure. The feeder cables then connect directly to the output lugs and/or bus bars provided on the main line circuit breaker.
  
- c) **Oversize Subbase Tank** - Specification requirements sometimes require an oversized tank to meet specific generator run-time demands. This can cause difficulty in completing final electrical connections. The tank should be designed with a stub-up area on the generator-end of the tank. However, depending on the placement of the engine-generator on the tank, feeder terminations may not rise in a close proximity to the circuit breaker enclosure. This could require the feeder conductors to enter the circuit breaker enclosure from the side or top, necessitating special fittings and/or hardware.

If the engine-generator is fitted with a weatherproof outdoor enclosure, it may be required to penetrate the side of the generator housing to facilitate final cable terminations. This will likely require special conduit, fittings and hardware. The feeder conductors would enter the housing on the side where the circuit breaker is mounted. The feeder conductors would enter the circuit breaker enclosure from the bottom, top or side as necessary, to complete final cable terminations. Check with the local inspection authority before proceeding.

**Closed Bottom Generator** - If the engine-generator is closed bottom, such as in a sound attenuated design, the bottom floor of the engine-generator must be cut to allow for a bottom entry electrical stub-up. If this is not possible, it may be required to route the feeder conductors on the outside of the engine-generator to reach the circuit breaker enclosure. This will likely require special conduit, fittings and hardware. The feeder conductors would enter the housing on the side where the circuit breaker is mounted. The feeder conductors would enter the circuit breaker enclosure from the bottom, top or side as necessary, to complete final cable terminations. Check with the local inspection authority before proceeding.

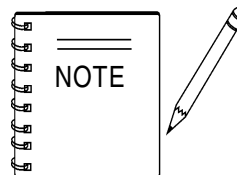

Refer to National Electric Code (NEC) Table 210.24 for specific circuit breaker current ratings for various size conductors.

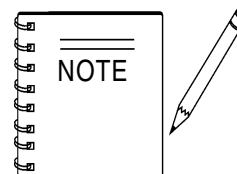

Refer to Table 19 “Main Line Circuit Breaker Sizing Information” for a complete listing of MQ Power generator main line circuit breakers available from the factory. This table details information about circuit breaker ampacity ratings, interrupt capacity, quantity of conductors per phase & size of output lugs available for each breaker, for each model MQ Power Standby Generators.

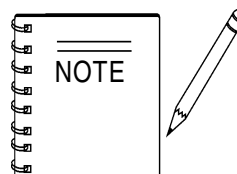

Refer to Figure XX “Voltage Connection Diagram” for a complete listing of output voltage connections available for each MQ Power Standby Generators.

# AC ELECTRICAL CONNECTIONS — SYSTEM GROUNDING

## System Grounding (continued)

Figure 30 below illustrates a typical system grounding for a 3-pole and 4-pole Automatic Transfer Switch (ATS).

### 3-Pole ATS

In the 3-pole ATS, note the generator neutral is connected to the ATS and is NOT bonded to ground at the generator. A neutral to ground bonding jumper is factory installed in all industrial gensets. Remove the jumper from the alternator saddle box to meet electrical codes and grounding requirements if required.

### 4-Pole ATS

In the 4-pole ATS system, a grounding electrode conductor and a bonding jumper are used to connect the generator neutral to ground. In some installations, a current transformer (CT) may be required for ground fault monitoring.

## **⚠ DANGER**

Bonding and grounding must be performed properly. All metallic parts that could become energized under abnormal conditions must be properly grounded. Failure to do so can cause electric current to flow, causing severe injury or death!

Typical requirements for bonding and grounding are given in the National Electrical Code, Article 250. All connections, wire sizes, etc. must conform to the requirements of the electrical codes in effect at the installation site.

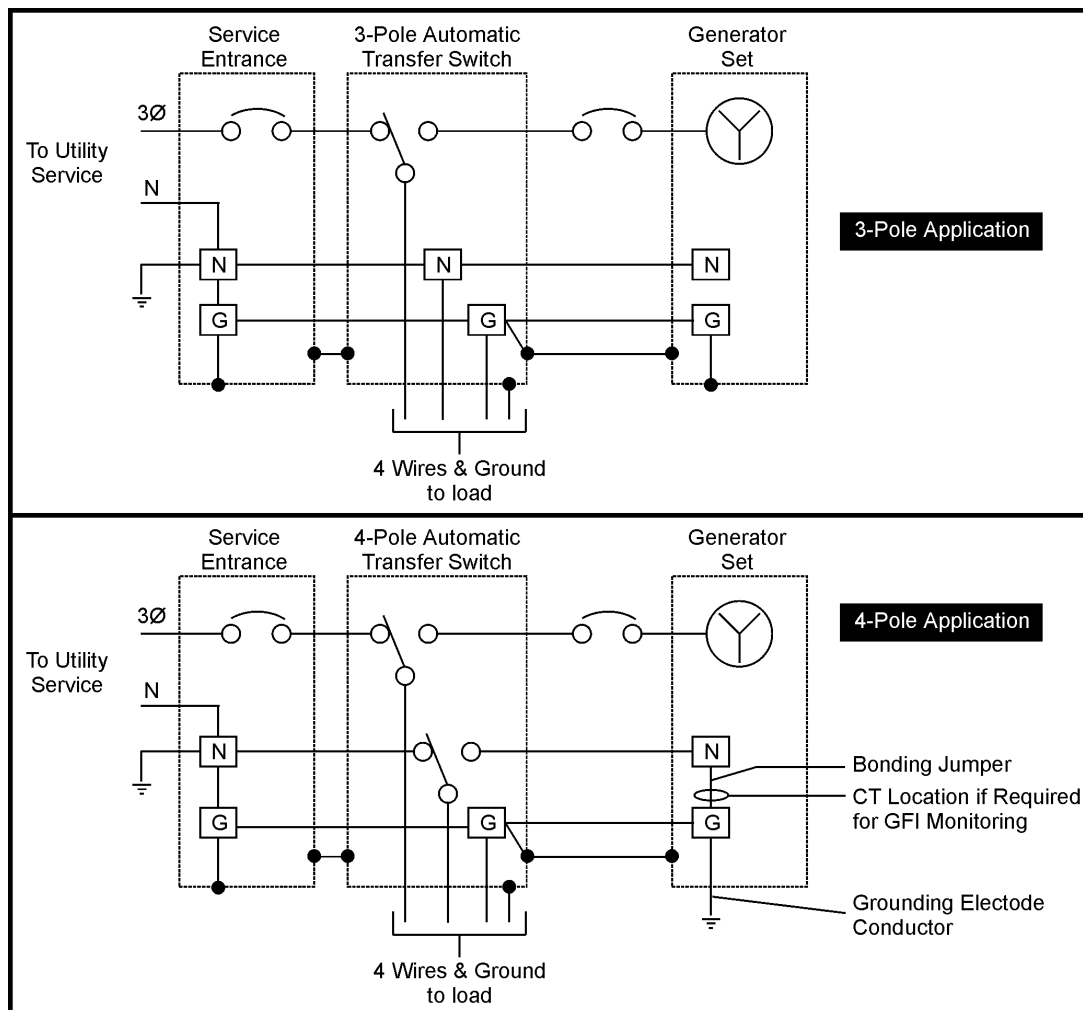

Figure 30. Typical System Grounding



# ELECTRICAL DISTRIBUTION SYSTEM

## Electrical Distribution System

Figure 32 below is a one-line diagram of a typical electrical distribution system that incorporates an emergency generator set.

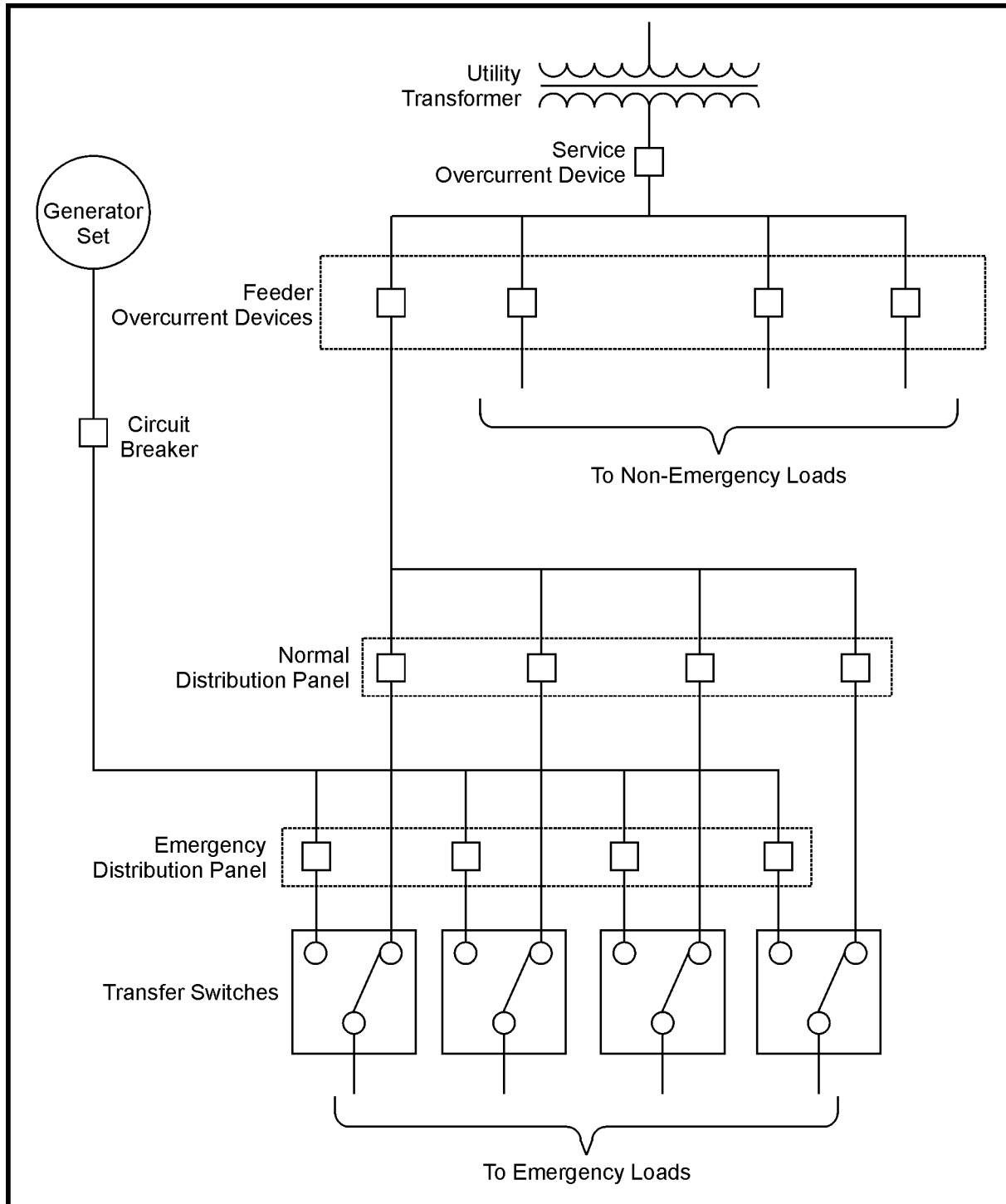

Figure 32. Typical Electrical Distribution System



For genset inspection, start-up and operational procedures, refer to the MQ Power Operators manual for the genset in use.

## General

Before attempting the initial start of the generator set, be sure it is serviced and ready for operation. Perform the following:

- Check ventilation and exhaust systems
- Check all mechanical connections
- Check the lubrication system for leaks
- Check control configuration options

## Ventilation

Verify all vents and ducts are open and free from any obstructions. Verify dampers, if used, operate properly.

## Exhaust System

Check the exhaust system for proper installation. Verify there is at least 12 inches (305 mm) clearance between exhaust pipes and combustible materials, all connections are tight, and the exhaust will not disperse near doors, windows, vents, or other openings.

## Mechanical Checks

Check the generator set for loose or damaged components and repair or replace as required.

## Digital Control

Configure digital control as specified in digital control manual.

## Electrical System

Verify all electrical connections are secure and wiring is complete and inspected. Replace and secure any access panels that may have been removed during installation.

## Battery Connections

The battery cables are supplied with the generator set. Service batteries, if necessary, as specified in the battery section of this manual. Install battery. Connect battery charger and jacket water heater if equipped.

## WARNING

Make sure the Run/Off/Manual switch is in the OFF position before connecting the battery cables. Failure to do so will result in immediate starting of the genset when connecting the generator set.

## Starting

After the installation is complete, make sure the lubricating system is primed and the system is working properly. Routine inspections are recommended.

Refer to the specified genset Operation manual for important safety precautions and recommended procedures for starting the genset. Only use the start-up procedures outlined in the "Genset Operation Manual" when starting of the genset is required. This is important to verify proper operation. Start the genset as outlined in the operation manual and verify all engine and generator display readings are accurate values.

# APPENDIX — INSTALLATION CHECKLIST

## INSTALLATION CHECKLIST

### General

- Genset wattage capacity is sufficient to handle maximum anticipated load.
- At least three (3) feet of clearance is provide around entire genset for servicing and ventilation.
- Genset is located in an area not subject to flooding.
- All operators have been thoroughly briefed on correct operating and exercise procedures.
- All operators have been thoroughly briefed on preventive maintenance procedures.
- All operators have read and understand all Safety Precautions and know how to react in an emergency.

### Genset Support

- Floor, roof, or earth on which the genset is mounted is strong enough and will not allow shifting or movement. Observe local codes on soil bearing capacity due to freezing and thawing.
- Genset is properly supported and retained to approved base which is separate and independent of the surface on which it rests. Vibration isolators are installed appropriately based on size requirements.
- Supporting base is large enough and exceeds 12 inches on all sides of genset.
- Genset is securely fastened to foundation or subbase fuel tank.

### Cooling Air Flow

- Cooling system is efficient, properly cools the engine, and ventilates genset area.
- Genset air inlet is faced into direction of strongest prevailing winds.
- Air inlet openings are unrestricted and at least 1-1/2 times larger than air outlet area.
- Cooling air outlet is on downwind side of building (if not, wind barrier is constructed).
- Proper ducting material (sheet metal, canvas) is used between radiator and air outlet.

### Diesel Fuel System

- Fuel tanks meet or exceed all local, state, and national codes.
- Fuel lines are properly installed, supported, and protected against damage.
- Flexible fuel lines is installed between main fuel supply line and genset to protect against vibration, expansion, and contraction.

- Fuel line shut-off valves are installed to prevent fuel flow in case of leaks.
- External fuel pumps are connected and operated to be turned "on" when genset is started and turned "off" when genset is shutdown.
- Fuel system is properly primed.
- No fuel leaks exist in supply line or engine fuel system.

### Exhaust System

- Exhaust piping is not restricted by tight bends and allowed to flow at maximum velocity.
- Condensation drain is installed at appropriate area.
- Exhaust system is tight and leakproof.
- Exhaust is routed safely outdoors to a well ventilated area away from people and building vents
- Operators are thoroughly briefed on the dangers of carbon monoxide gas, preventing the buildup of this gas in inhabited areas.
- Areas around the genset are well ventilated. No possibility of exhaust fumes entering building doors, windows, or intake fans.
- Exhaust piping passing through walls or ceilings have approved fireproof materials and are in compliance with all codes.
- Exhaust piping is large enough to prevent back pressure on engine.

### AC and DC Wiring

- Wire sizes, insulation, conduits, and connection methods all meet applicable codes.
- AC and DC wires are separated in their own conduit to prevent electrical induction.
- All load, line, and generator connections are proper and correct.
- Genset and equipment are correctly grounded.

### Genset Pre-start

- All laws and codes are meet and all certificates received.
- Genset engine is properly serviced with oil and coolant.
- Batteries are properly installed, serviced, and charged.
- Battery charger and engine coolant heater are connected and operational.
- All genset covers and safety shields are installed properly.
- All fuel and coolant shut-off valves are operational.
- Fuel system is primed.
- Operators have read the instruction manual.

# APPENDIX — MAIN-LINE CIRCUIT BREAKER

**TABLE 19. FACTORY RECOMMENDED  
MAIN LINE CIRCUIT BREAKERS - KD SERIES GENERATORS**

Generator Model	Cutler Hammer Model No.	Generator Output (Voltage)	Generator Output (Amps)	Breaker Frame Size (Amps)	Breaker Trip Rating (Amps)	Interrupting Rating RMS (Sym Amps)	Cable Size (kcmil) {Note 1}	Max. No. Cables Per Phase	Type Of Connection {Note 2}	Torque Rating Of Lugs
KD75V	JG3250	240V - 1Ø	250	250	250	18,000	#4 ~ 350	1	Aluminum Lugs	TBD
		208V - 3Ø	260					1		
		240V - 3Ø	226					1		
	FJ3125	480V - 3Ø	113	225	125	14,000	#4 ~ 1/0	1		
KD100V	KG3300	240V - 1Ø	275	400	300	18,000	250 ~ 500	1	Aluminum Lugs	TBD
	KG3350	208V - 3Ø	347		350			1		
	KG3300	240V - 3Ø	301		300			1		
		FG3150	480V - 3Ø	150	225	150	14,000	#4 ~ 1/0	1	
KD115V	KG3350	240V - 1Ø	313	400	350	18,000	250 ~ 500	1	Aluminum Lugs	TBD
	KG3400	208V - 3Ø	399		400		3/0 ~ 250	2		
	KG3350	240V - 3Ø	346		350		250 ~ 500	1		
		JG3225	480V - 3Ø	173	250	175	14,000	#4 ~ 350	1	
KD150V	KG3350	240V - 1Ø	333	400	350	18,000	250 ~ 500	1	Aluminum Lugs	TBD
	LG3600	208V - 3Ø	520		600		600	400 ~ 500		
	LG3450	240V - 3Ø	451	250	450	14,000	#4 ~ 4/0	2		
	JG3225	480V - 3Ø	226		225		#4 ~ 350	1		
KD175V	LG3600	240V - 1Ø	542	600	600	18,000	400 ~ 500	2	Aluminum Lugs	TBD
	LG3601	208V - 3Ø	607					2		
	LG3602	240V - 3Ø	526					2		
		KG3300	480V - 3Ø	263	400	300	14,000	250 ~ 500		
KD200V	MDL3700	208V - 3Ø	694	800	700	65,000	3/0 ~ 400	3	Aluminum Lugs	TBD
	LG3600	240V - 3Ø	601	600	600	18,000	400 ~ 500	2		
	KG3300	480V - 3Ø	301	400	300	14,000	250 ~ 500	1		
KD250V	NG31000	208V - 3Ø	867	1,200	1,000	18,000	3/0 ~ 400	3	Aluminum Lugs	TBD
	MDL3800	240V - 3Ø	752	800	800	65,000		3		
	KG3400	480V - 3Ø	376	400	400	14,000		2		
KD300V	NG31000	208V - 3Ø	1041	1,200	1,000	18,000	3/0 ~ 400	3	Aluminum Lugs	TBD
		240V - 3Ø	902					3		
		LG3500	480V - 3Ø	453	600	500	14,000	3/0 ~ 350		
KD350V	NG31200	208V - 3Ø	1214	1,200	1,200	18,000	4/0 ~ 500	4	Aluminum Lugs	TBD
	NG31000	240V - 3Ø	1052		1,000		3/0 ~ 400	3		
		LG3600	480V - 3Ø	526	600	600	14,000	4/0 ~ 500		
KD400V	RD316T33W	208V - 3Ø	1388	2,500	1,600	125,000	500 ~ 1000	4	Aluminum Lugs	TBD
	NG31200	240V - 3Ø	1203	1,200	1,200	18,000	4/0 ~ 500	4		
	LG3600	480V - 3Ø	601	600	600	14,000	400 ~ 500	2		
KD450V	RD316T33W	208V - 3Ø	1561	2,500	1,600	125,000	500 ~ 1000	4	Aluminum Lugs	TBD
		240V - 3Ø	1353					4		
		MDL3700	480V - 3Ø	677	800	700	50,000	3/0 ~ 400		
KD500V	RD320T33W	208V - 3Ø	1735	2,500	2,000	125,000	#2 ~ 600	6	Aluminum Lugs	TBD
		240V - 3Ø	1503		1,600	125,000	500 ~ 1000	4		
		MDL3800	480V - 3Ø	752	800	800	50,000	3/0 ~ 400		

- NOTES: 1. Refer to National Electric Code (NEC) for specific conductor sizes based on current and temperature ratings.  
2. Lug sizes are given for standard circuit breaker setup. All lugs listed are made of aluminum and are compatible with both aluminum and copper conductors.

# APPENDIX — ENGINE SPECIFICATIONS

## TABLE 20. MQ POWER INDUSTRIAL ENGINE SPECIFICATIONS

Generator	KD75V	KD100V	KD115V	KD150V	KD175V	KD200V
Diesel Engine Model	Volvo TD520GE	Volvo TAD520GE	Volvo TD720GE	Volvo TAD720GE	Volvo AD741GE	
Engine RPMs	1800					
Engine Design	Four Cycle Diesel Water Cooled					
Displacement (liters)	4.76	4.76	7.15	7.15	7.28	
Number of Cylinders	4			6		
Bore x Stroke (millimeters)	108 x 130				107 x 135	
Horsepower at Rated Speed	115	140	187	212	310	
Governor Type	Electronic					
Frequency Regulation	0.25% Of Mean Value For Constant Loads From No Load To Full Load					
<b>Fuel System</b>						
Fuel Injection Pump Make / Type	BOSCH / Direct Injection					
Recommended Fuel Type	ASTM-D975 #2 Diesel					
Maximum Fuel Flow (gal/hr)	118.90				34.30	
Maximum Suction Head Allowable (feet)	4.90				6.60	
Gallons Per Hour (at full load)	6.10	7.10	8.90	10.41	14.70	
Gallons Per Hour (at 3/4 load)	4.60	5.30	6.70	7.87	11.10	
Gallons Per Hour (at 1/2 load)	3.10	3.70	4.60	5.47	7.40	
Gallons Per Hour (at 1/4 load)	1.90	2.30	2.90	3.12	3.70	
<b>Engine Electrical System</b>						
Battery Voltage	12VDC				24VDC	
Battery Type	1 x Type 4D				2 x Type 4D	
Battery Cold Cranking Amps - Each Battery	1,000 Amps For 30-Seconds At 0°F					
Starting System	DC Electric Starter Motor Negative Ground					
Belt-Driven Battery Charging Alternator	55 Ampere				60 Ampere	

# APPENDIX — ENGINE SPECIFICATIONS

## TABLE 20. MQ POWER INDUSTRIAL ENGINE SPECIFICATIONS

GENERATOR	KD75V	KD100V	KD115V	KD150V	KD175V	KD200V
<b>Engine Exhaust System</b>						
Exhaust Manifold Type	Dry Manifold					
Exhaust Flow At Rated Output (cfm)	618	699	918	1,105	1,511	1,511
Exhaust Temperature At Rated Output (°F)	986	838	941	811	1,031	1,031
Maximum Allowable Backpressure (in/wc)	20.0	28.0	28.0	28.0	40.0	40.0
Heat Rejection To Exhaust (BTU/min)	4,379	4,646	6,597	6,881	10,773	10,773
<b>Engine Lubrication System</b>						
Type Of System	Full Pressure Lubrication					
Total Oil Capacity With Filter (gallons)	3.4	3.4	5.3		7.7	
Oil Filter Design	Full Flow					
Oil Cooler	Integral					
Oil Pressure At Rated Speed/Temp (psi)	64	64	65		44 ~ 73	
<b>Engine Cooling System</b>						
Standard Radiator Design	Skid-Mount; Horizontal Discharge					
Ambient Temperature Rating	104°F (40°C) With 50/50% Mixture Glycol & Water					
Total System Coolant Capacity (gallons)	2.7	3.3	3.2	3.7	6.9	
Coolant Flow (gal/min)	54	54	58	58	65	
Radiator Cooling Air (cfm)	3,810	3,810	4,870	6,570	5,510	
Maximum Heat Rejection To Coolant (btu/min)	3,168	3,230	4,766	4,828	7,621	
Maximum External Coolant System Restriction (psi)	5.1	5.1	5.1	5.1	6.5	6.5
Maximum Static Pressure Head (psi)	14.50	14.50	14.50	14.50	7.25	7.25
Maximum Top Tank Temperature (°F)	230	221	230	221	217	217

# APPENDIX — ENGINE SPECIFICATIONS

## TABLE 20. MQ POWER INDUSTRIAL ENGINE SPECIFICATIONS

Generator	KD250V	KD300V	KD350V	KD400V	KD450V	KD500V
Diesel Engine Model	Volvo TAD1031GE	Volvo TAD1240GE	Volvo TAD1241GE	Volvo TAD1242GE	Volvo TAD1631GE	
Engine RPMs	1800					
Engine Design	Four Cycle Diesel Water Cooled					
Displacement (liters)	9.6	12.13			16.12	
Number of Cylinders	6					
Bore x Stroke (millimeters)	121 x 140	131 x 150			144 x 165	
Horsepower at Rated Speed	390	449	514	585	743	
Governor Type	Electronic					
Frequency Regulation	0.25% Of Mean Value For Constant Loads From No Load To Full Load					
<b>Fuel System</b>						
Fuel Injection Pump Make / Type	BOSCH / Direct Injection					
Recommended Fuel Type	ASTM-D975 #2 Diesel					
Maximum Fuel Flow (gal/hr)	39.60	145.0			56.80	
Maximum Suction Head Allowable (feet)	6.60				9.80	
Gallons Per Hour (at full load)	20.50	23.80		28.40	36.80	
Gallons Per Hour (at 3/4 load)	15.30	17.90		21.30	27.60	
Gallons Per Hour (at 1/2 load)	10.20	11.90		14.20	18.40	
Gallons Per Hour (at 1/4 load)	5.10	6.00		7.10	9.20	
<b>Engine Electrical System</b>						
Battery Voltage	24VDC					
Battery Type	2 x Type 4D					
Battery Cold Cranking Amps - Each Battery	1,000 Amps For 30-Seconds At 0°F					
Starting System	DC Electric Starter Motor Negative Ground					
Belt-Driven Battery Charging Alternator	60 Ampere					

# APPENDIX — ENGINE SPECIFICATIONS

## TABLE 20. MQ POWER INDUSTRIAL ENGINE SPECIFICATIONS

GENERATOR	KD75V	KD100V	KD115V	KD150V	KD175V	KD200V
<b>Engine Exhaust System</b>						
Exhaust Manifold Type	Dry Manifold					
Exhaust Flow At Rated Output (cfm)	2,225	2,430	2,543	3,002	4,117	4,117
Exhaust Temperature At Rated Output (°F)	1,040	869	914	1,049	1,035	1,035
Maximum Allowable Backpressure (in/wc)	40.2	40.0	40.2	40.2	28.1	28.1
Heat Rejection To Exhaust (BTU/min)	16,719	15,355	17,402	17,402	27,410	27,4410
<b>Engine Lubrication System</b>						
Type Of System	Full Pressure Lubrication					
Total Oil Capacity With Filter (gallons)	9.5	9.2			16.9	
Oil Filter Design	Full Flow					
Oil Cooler	Integral					
Oil Pressure At Rated Speed/Temp (psi)	44 ~ 73	58 ~ 80			44 ~ 73	
<b>Engine Cooling System</b>						
Standard Radiator Design	Skid-Mount w/ Horizontal Discharge					
Ambient Temperature Rating	104°F (40°C) With 50/50% Mixture Glycol & Water					
Total System Coolant Capacity (gallons)	5.6	6.3	6.3	9.2		
Coolant Flow (gal/min)	92	95	95	166		
Radiator Cooling Air (cfm)	6,570	9,430	12,500	14,408		
Maximum Heat Rejection To Coolant (btu/min)	6,540	8,417	8,132	9,838	13,364	
Maximum External Coolant System Restriction (psi)	6.5	8.7	8.7	8.7	6.5	
Maximum Static Pressure Head (psi)	7.25	7.25	7.25	7.25	7.00	
Maximum Top Tank Temperature (°F)	217	217	217	217	217	

# APPENDIX — DIMENSIONS AND WEIGHTS

**TABLE 21. MQ POWER GENERATOR DIMENSIONS & WEIGHTS**

Generator	KD75V	KD100V	KD115V	KD150V	KD175V	KD200V
<b>Skid Mount Open Unit (inches)</b>						
Length	75	93	95	102	101	109
Width	49	49	49	49	57	57
Height	50	50	51	51	59	59
Generator Wet Weight (lbs)	2,337	2,392	3,147	3,178	3,928	4,033
<b>Outdoor Housed Unit (inches)</b>						
Length	85	93	105	105	115	115
Width	49	49	49	49	57	57
Height	61	61	67	67	74	74
Generator Wet Weight (lbs)	2,403	2,460	3,058	3,079	4,067	4,172
<b>Sound Attenuated Unit (inches)</b>						
Length	119	119	139	139	164	164
Width	49	49	49	49	56	56
Height	61	61	67	67	74	74
Generator Wet Weight (lbs)	TBD	TBD	3,620	3,620	TBD	TBD

# APPENDIX — DIMENSIONS AND WEIGHTS

## TABLE 21. MQ POWER GENERATOR DIMENSIONS & WEIGHTS

Generator	KD250V	KD300V	KD350V	KD400V	KD450V	KD500V
<b>Skid Mount Open Unit (inches)</b>						
Length	126	126	131	131	142	141
Width	57	57	57	57	61	61
Height	65	63	63	63	70	70
Generator Wet Weight (lbs)	4,884	5,536	6,032	6,042	7,129	7,129
<b>Outdoor Housed Unit (inches)</b>						
Length	131	131	131	131	145	145
Width	57	57	57	57	61	61
Height	104	104	104	104	113	113
Generator Wet Weight (lbs)	5,007	5,701	6,197	6,207	7,387	7,387
<b>Sound Attenuated Unit (inches)</b>						
Length	166	166	166	166	184	184
Width	56	56	56	56	61	61
Height	104	104	104	104	113	113
Generator Wet Weight (lbs)	6,085	6,779	7,275	7,285	TBD	TBD

# APPENDIX — GENERATOR SPECIFICATIONS

## TABLE 22. MQ POWER INDUSTRIAL GENERATOR SPECIFICATIONS

Generator	KD75V	KD100V	KD115V	KD150V	KD175V	KD200V
Standby Power Output Rating	75 KW (93.75 KVA)	100 KW (125 KVA)	115 KW (144 KVA)	150 KW (187.5 KVA)	175 KW (219 KVA)	200 KW (250 KVA)
Prime Power Output Rating	68 KW (85 KVA)	90 KW (112.5 KVA)	116 KW (144 KVA)	135 KW (169 KVA)	158 KW (197.5 KVA)	180 KW (225 KVA)
Design	Synchronous, Revolving Field, Self-Ventilated, Drip-Proof, Single Bearing					
Number Of Poles	4-Pole Design					
Generator RPM	1800					
Insulation Class	Class H					
Excitation System	Brushless With Automatic Voltage Regulator					
Armature Connection	Wye or Delta					
Power Factor	0.8					
Frequency	60 Hertz					
<b>Generator Output Single Phase (1Ø)</b>						
Voltage Output -	120,127,139,240,254,277 Broad Range Reconnectable					
Amperage Output - 120/240VAC	250	275	313	333	542	633
<b>Generator Output Three Phase (3Ø)</b>						
Voltage Output -	208,220,240,416,440,480 Broad Range Reconnectable					
Amperage Output - 120/208VAC	260	347	399	520	607	694
Amperage Output - 120/240VAC	226	301	346	451	526	601
Amperage Output - 277/480VAC	113	150	173	226	263	301
Voltage Regulation (No Load To Full Load)	±1.0%					
<b>Environmental Operation</b>						
Control Panel Operation (ICS-30 Control)	0°C ~ +50°C					
Control Panel Storage Temperature	-20°C ~ +70°C					
Cooling System Rating	104°F (40°C) With 50/50% Mixture Glycol & Water					

# APPENDIX — GENERATOR SPECIFICATIONS

## TABLE 22. MQ POWER INDUSTRIAL GENERATOR SPECIFICATIONS

Generator	KD250V	KD300V	KD350V	KD400V	KD450V	KD500V
Standby Power Output Rating	250 KW (312.5 KVA)	300 KW (375 KVA)	350 KW (437.5 KVA)	400 KW (500 KVA)	450 KW (562.5 KVA)	500 KW (625 KVA)
Prime Power Output Rating	225 KW (281 KVA)	270 KW (337.5 KVA)	315 KW (394 KVA)	360 KW (450 KVA)	400 KW (500 KVA)	450 KW (562.5 KVA)
Design	Synchronous, Revolving Field, Self-Ventilated, Drip-Proof, Single Bearing					
Number Of Poles	4-Pole Design					
Generator RPM	1800					
Insulation Class	Class H					
Excitation System	Brushless With Automatic Voltage Regulator					
Armature Connection	Wye or Delta					
Power Factor	0.8					
Frequency	60 Hertz					
<b>Generator Output Single Phase (1Ø)</b>						
Voltage Output -	120,127,139,240,254,277 Broad Range Reconnectable					
<b>Generator Output Three Phase (3Ø)</b>						
Voltage Output -	208,220,240,416,440,480 Broad Range Reconnectable					
Amperage Output - 120/208VAC	867	1,041	1,214	1,388	1,561	1,735
Amperage Output - 120/240VAC	752	902	1,052	1,203	1,353	1,503
Amperage Output - 277/480VAC	376	453	526	601	677	752
Voltage Regulation (No Load To Full Load)	±1.0%					
<b>Environmental Operation</b>						
Control Panel Operation (ICS-30 Control)	0°C ~ +50°C					
Control Panel Storage Temperature	-20°C ~ +70°C					
Cooling System Rating	104°F (40°C) With 50/50% Mixture Glycol & Water					

# APPLICATION & INSTALLATION MANUAL

## **HERE'S HOW TO GET HELP**

PLEASE HAVE THE MODEL AND SERIAL  
NUMBER *ON-HAND* WHEN CALLING

### **MULTIQUIP'S MAIN PHONE NUMBERS**

800-421-1244      FAX: 310-537-3927  
310-537-3700

### **PARTS DEPARTMENT**

800-427-1244      FAX: 800-672-7877  
310-537-3700      FAX: 310-637-3284

### **MAYCOPARTS**

800-306-2926      FAX: 800-672-7877  
310-537-3700      FAX: 310-637-3284

### **SERVICE DEPARTMENT**

800-478-1244      FAX: 310-537-4259  
310-537-3700

### **MQPOWER SERVICE DEPARTMENT**

800-835-2551      FAX: 310-638-8046  
310-537-3700

### **TECHNICAL ASSISTANCE**

800-478-1244      FAX: 310-631-5032

### **WARRANTY DEPARTMENT**

800-421-1244, EXT. 279      FAX: 310-537-1173  
310-537-3700, EXT. 279



#### **MQPOWER**

A Division of Multiquip Inc.  
POST OFFICE BOX 6254  
CARSON, CA 90749  
310-537-3700 • 800-421-1244  
FAX: 310-632-2656  
E-MAIL: [mqpower@multiquip.com](mailto:mqpower@multiquip.com)  
WWW: [www.mqpower.com](http://www.mqpower.com)

#### **PARTS DEPARTMENT:**

800-427-1244  
FAX: 800-672-7877

#### **SERVICE DEPARTMENT:**

800-835-2551  
FAX: 310-638-8046