

OPERATION AND PARTS MANUAL

STOW

A DIVISION OF MULTIQUIP INC.

MODEL G-4.5R

PORTABLE AC GENERATOR

(GASOLINE ENGINE)

S/N 5498030 AND BELOW
S/N 5498031 AND ABOVE

Revision #2 (10/28/04)

**THIS MANUAL MUST ACCOMPANY
THE EQUIPMENT AT ALL TIMES.**



WARNING

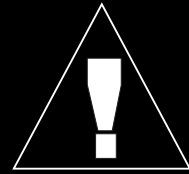

CALIFORNIA — Proposition 65 Warning

Engine exhaust and some of its constituents are known to the State of California to cause cancer, birth defects and other reproductive harm.

HERE'S HOW TO GET HELP

PLEASE HAVE THE MODEL AND SERIAL
NUMBER *ON-HAND* WHEN CALLING

STOW MAIN OFFICE

Post Office Box 6254

Carson, Ca 90749

Email: stow@multiquip.com

Internet: www.stowmfg.com

888-252-STOW

FAX: 310-537-1986

PARTS DEPARTMENT

800-427-1244

310-537-3700

FAX: 800-672-7877

FAX: 310-637-3284

SERVICE DEPARTMENT

800-421-1244

310-537-3700

FAX: 310-537-4259

TECHNICAL ASSISTANCE

800-478-1244

FAX: 310-631-5032

WARRANTY DEPARTMENT

800-421-1244, EXT. 279

310-537-3700, EXT. 279

FAX: 310-537-1173

SALES DEPARTMENT

310-661-4242

877-289-7869 (877-BUY-STOW)

FAX: 310-604-9237

© COPYRIGHT 2004, STOW CONSTRUCTION EQUIPMENT

STOW Construction Equipment and the STOW logo are registered trademarks of STOW and may not be used, reproduced, or altered without written permission. All other trademarks are the property of their respective owners and used with permission.

This manual **MUST** accompany the equipment at all times. This manual is considered a permanent part of the equipment and should remain with the unit if resold.

The information and specifications included in this publication were in effect at the time of approval for printing. Illustrations are based on the *G-2.9R Portable AC Generator*. STOW Construction Equipment reserves the right to discontinue or change specifications, design or the information published in this publication at any time without notice and without incurring any obligations.

**To find the latest revision of this
publication, visit our website at:
www.stowmfg.com**



STOW G-4.5R — AC Portable Generator

Here's How To Get Help	3
Table Of Contents	4
Parts Ordering Procedures	5
Dimensions	6
Specifications	7
Safety Alert Message Symbols	8-9
Rules for Safe Operation	10-12
Operation and Safety Decals (S/N 5498030 & Below)	14
Operation and Safety Decals (S/N 5498031 & Above)	15
General Information	16
Load Application	17
Controls and Indicators	18-21
Generator Refueling	22
Installation	23-24
Pre-Inspection	25
Pre-Inspection (Engine)	26
Initial Start-up (Engine)	27
Initial Start-up (Engine/Operation)	28-29
Preparation For Long Term Storage	30
Maintenance	32-33
Wiring Diagram (S/N S/N 5498030 & Below)	34
Wiring Diagram (S/N 5498031 & Above)	35
Troubleshooting (Engine)	36-37
Troubleshooting (Generator)	38
Explanation Of Codes In Remarks Column	40
Suggested Spare Parts	41

Generator Component Drawings

Nameplate and Decals (S/N 5498030 & Below)	42-43
Nameplate and Decals (S/N 5498031 & Above)	44-45
Generator Assembly	46-47
Control Box Assembly (S/N 5498030 & Below)	48-49
Control Box Assembly (S/N 5498031 & Above)	50-51
Pipe Frame Assembly (S/N 5498030 & Below)	52-53
Pipe Frame Assembly (S/N 5498031 & Above)	54-55

ROBIN EX270D20110 Engine (EPA)

Crankcase Assembly	56-57
Crankshaft, Piston Assembly	58-59
Governor Assembly	60-61
Intake and Exhaust Assembly	62-63
Air Cleaner Assembly	64-65
Cooling Starting Assembly	66-67
Fuel Lubricant Assembly	68-69
Flywheel Assembly	70-71
Electric Device Assembly	72-73
Terms and Conditions Of Sale — Parts	74

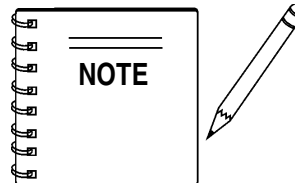

As a continuing effort to update our parts book, contact the STOW literature department for the latest revision of your "Operation and Parts Manual"

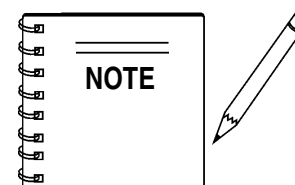

Specification and part number are subject to change without notice.

PARTS ORDERING PROCEDURES

When ordering parts, please supply the following information:

- Dealer account number
- Dealer name and address
- Shipping address (if different than billing address)
- Return fax number
- Applicable model number
- Quantity, part number and description of each part
- Specify preferred method of shipment:
 - ✓ FedEx or UPS Ground
 - ✓ FedEx or UPS Second Day or Third Day
 - ✓ FedEx or UPS Next Day
 - ✓ Federal Express Priority One
 - ✓ DHL
 - ✓ Truck

Note: Unless otherwise indicated by customer, all orders are treated as "Standard Orders", and will ship within 24 hours. We will make every effort to ship "Air Shipments" the same day that the order is received, if prior to 2PM west coast time. "Stock Orders" must be so noted on fax or web forms.



Here's how to get help...

Please have the model and serial number on hand when calling.

STOW MAIN OFFICE

18910 Wilmington Ave. 800-421-1244
 Carson, CA 90746 FAX: 310-537-3927
 Email: stow@stowmfg.com
 Internet: www.stowmfg.com

SALES DEPARTMENT

310-661-4242 Fax: 310-604-9237
 877-289-7869 (877-BUY-STOW)

PARTS DEPARTMENT

800-427-1244 FAX: 800-672-7877
 310-537-3700 FAX: 310-637-3284

SERVICE DEPARTMENT

800-421-1244 FAX: 310-537-4259
 310-537-3700

TECHNICAL ASSISTANCE

800-478-1244 FAX: 310-631-5032

WARRANTY DEPARTMENT

800-421-1244, EXT. 279 FAX: 310-537-1173
 310-537-3700, EXT. 279

Place Your Parts Order Via Web or Fax For Even More Savings!

(Domestic USA Dealers Only)

Extra Discounts!

All parts orders which include complete part numbers and are received by our automated web parts order system, or by fax qualify for the following extra discounts:

Ordered via	Standard orders	Stock orders (\$750 list and above)
Fax	3%	10%
Web	5%	10%

Special freight allowances when you order 10 or more line items via Web or Fax! **

FedEx Ground Service **at no charge for freight**

No other allowances on freight shipped by any other carrier.

**Common nuts, bolts and washers (all items under \$1.00 list price) do not count towards the 10+ line items.

NOTE: DISCOUNTS ARE SUBJECT TO CHANGE

STOW

A DIVISION OF MULTIQUIP INC.
STOW CONSTRUCTION EQUIPMENT
 A DIVISION OF MULTIQUIP INC.

POST OFFICE BOX 6254 CARSON, CA 90749
 888-252-STOW [888-252-7869] 310-537-3700
 FAX: 310-537-1986 FAX: 800-556-1986
 E-MAIL: stow@multiquip.com INTERNET: www.stowmfg.com

Direct TOLL-FREE access to our Parts Department:

Toll-free nationwide — 800-427-1244

Toll-free FAX — 800-6-PARTS-7 (800/672-7877)

STOW G-4.5R — DIMENSIONS

S/N5498030 AND BELOW

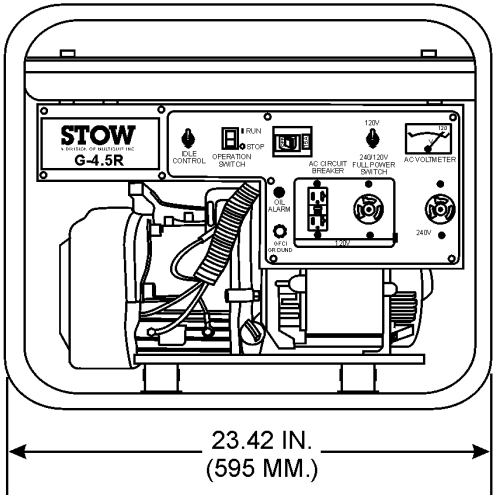

S/N5498031 AND ABOVE

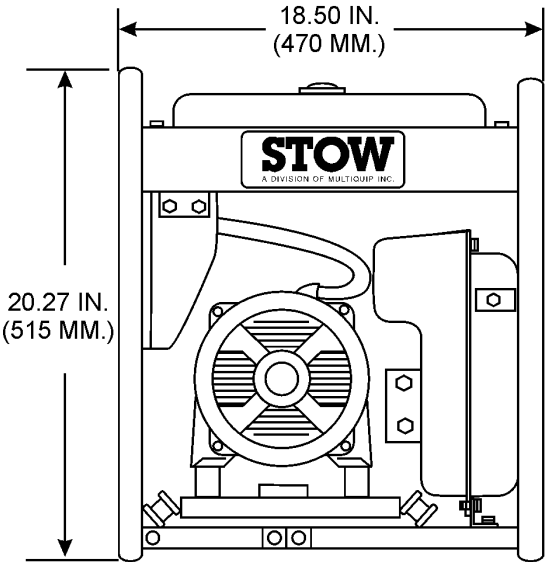
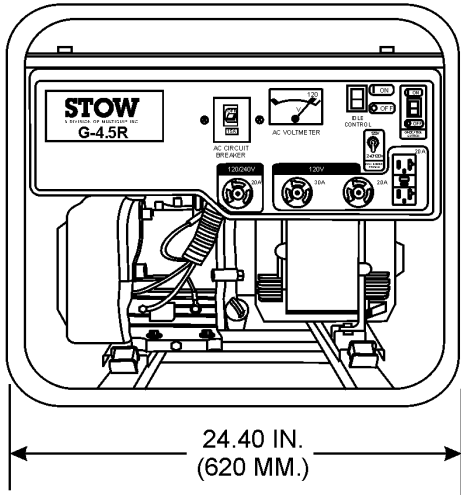

S/N5498030 AND BELOW

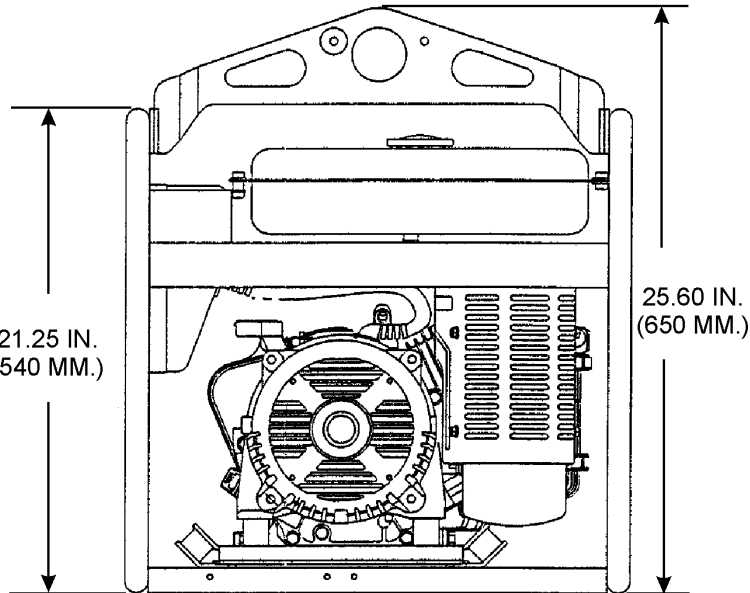

S/N5498031 AND ABOVE

Figure 1. Dimensions

Table 1. Specifications

MODEL		G-4.5R
GENERATOR	Type	2-Pole, Brushless Type Revolving Field
	Frequency (Hz)	60
	Continuous Output (kW)	3.70
	Maximum Output (kW)	4.5
	Voltages (VAC)	120/240
	Max/Continuous Amps 120 VAC	37.5/30.8
	Max/Continuous Amps 240 VAC	18.75/15.4
	Rated Speed (RPM)	3600
	Power Factor	1.0
	Dimension (L x W x H) in. (mm)	23 X 18.5 X 20.25 (595 X 470 X 515)
	Dry Net Weight lbs. (kg) Includes Engine	149 (68)
	ENGINE	Model
Type		Air-cooled, 4-stroke, Single Cylinder, Overhead Camshaft, Gasoline Engine
Displacement (cc)		265
Continuous Output (kW/min)		5.1 @3600
Maximum Output (kW/min)		9.0 @4000
Fuel Tank Capacity Gal. (L)		4.2 (19)
Fuel		Non-leaded Automobile Gasoline
Lube Oil Capacity Qts. (L)		1.16 (1.1)
Speed Control Method		Centrifugal Fly-weight Type
Starting Method		Recoil Start
Dimension (L x W x H) in. (mm)		13.97 X 16.5 X 16.14 (355 X 420 X 410)
Dry Net Weight lbs. (kg)		46.3 (21)

Effects of Altitude and Heat

The maximum output of the engine listed above is applicable to supplying electrical power for continuous service at ambient conditions in accordance with SAE Test cord J607. The above ambient conditions are at standard sea level, with a barometric reading of 29.92 inches and a temperature of 60 degrees fahrenheit.

Generally, the engine output power will decrease 3 1/2% for each 1000 feet of altitude above sea level, and 1% for each 10° F fahrenheit above the standard temperature of 60° F

STOW G-4.5R — SAFETY MESSAGE ALERT SYMBOLS

FOR YOUR SAFETY AND THE SAFETY OF OTHERS!

Safety precautions should be followed at all times when operating this equipment. Failure to read and understand the Safety Messages and Operating Instructions could result in injury to yourself and others.

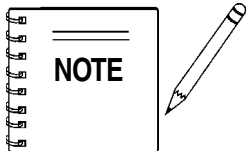
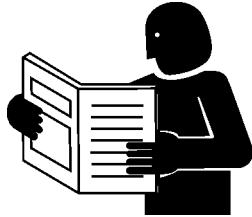

This Owner's Manual has been developed to provide complete instructions for the safe and efficient operation of the **STOW Model G-4.5R Portable Generator**. Refer to the engine manufacturers instructions for data relative to its safe operation.

Before using this generator, ensure that the operating individual has read and understands all instructions in this manual.

SAFETY MESSAGE ALERT SYMBOLS

The three (3) Safety Messages shown below will inform you about potential hazards that could injure you or others. The Safety Messages specifically address the level of exposure to the operator, and are preceded by one of three words: **DANGER**,

DANGER

You **WILL** be **KILLED** or **SERIOUSLY INJURED** if you **DO NOT** follow these directions.

WARNING

You **CAN** be **KILLED** or **SERIOUSLY INJURED** if you **DO NOT** follow these directions.

CAUTION

You **CAN** be **INJURED** if you **DO NOT** follow these directions.

HAZARD SYMBOLS

Potential hazards associated with the operation of a **STOW G-4.5R Portable Generator** will be referenced with Hazard Symbols which appear throughout this manual, and will be referenced in conjunction with Safety Message Alert Symbols.

WARNING Lethal Exhaust Gas Hazards

Engine exhaust gases contain poisonous carbon monoxide. This gas is colorless and odorless, and can cause death if inhaled. **NEVER** operate this equipment in a confined area or enclosed structure that does not provide ample free flow air.



WARNING Explosive Fuel Hazards

Gasoline is extremely flammable, and its vapors can cause an explosion if ignited. **DO NOT** start the engine near spilled fuel or combustible fluids.



DO NOT fill the fuel tank while the engine is running or hot. **DO NOT** overfill tank, since spilled fuel could ignite if it comes into contact with hot engine parts or sparks from the ignition system. Store fuel in approved containers, in well-ventilated areas and away from sparks and flames.

WARNING Burn Hazards

Engine components can generate extreme heat. To prevent burns, **DO NOT** touch these areas while the engine is running or immediately after operations. Never operate the engine with heat shields or heat guards removed.



WARNING Respiratory Hazards

ALWAYS wear approved *respiratory* protection when required.



STOW G-4.5R — SAFETY MESSAGE ALERT SYMBOLS



CAUTION

Rotating Parts Hazards

NEVER operate equipment with covers, or guards removed. Keep fingers, hands, hair and clothing away from all moving parts to prevent injury.



CAUTION

Equipment Damage Hazards

Other important messages are provided throughout this manual to help prevent damage to your portable generator, other property, or the surrounding environment.



CAUTION

Accidental Starting Hazards

ALWAYS place the power source, circuit breakers or **ON/OFF** switch in the **OFF** position, when the generator is not in use, unless connected to transfer switch.



CAUTION

Eye and Hearing Hazards

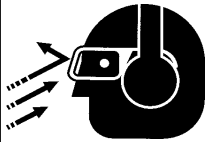

ALWAYS wear approved eye and hearing protection.

STOW G-4.5R — RULES FOR SAFE OPERATION

DANGER

Read this manual!

Failure to follow instructions in this manual may lead to serious injury or even death! This equipment is to be operated by trained and qualified personnel only! This equipment is for industrial use only.

The following safety guidelines should always be used when operating the STOW G-4.5R Portable Generator:

GENERAL SAFETY

■ **DO NOT** operate or service this equipment before reading this entire manual.



■ This equipment should not be operated by persons under 18 years of age.

■ **NEVER** operate this equipment without proper protective clothing, shatterproof glasses, steel-toed boots and other protective devices required by the job.



■ **NEVER** operate this equipment when not feeling well due to fatigue, illness or taking medicine.



■ **NEVER** operate this equipment under the influence of **drugs** or **alcohol**.



■ **ALWAYS** wear proper respiratory (mask), hearing and eye protection equipment when operating the generator.



■ Whenever necessary, replace nameplate, operation and safety decals when they become difficult read.

■ Manufacturer does not assume responsibility for any accident due to equipment modifications.

■ **NEVER** use accessories or attachments, which are not recommended by STOW for this equipment. Damage to the equipment and/or injury to user may result.

■ **NEVER** touch the hot exhaust manifold, muffler or cylinder. Allow these parts to cool before servicing engine or generator.



■ The engine section of this generator requires an adequate free flow of cooling air. **NEVER** operate the generator in any enclosed or narrow area where free flow of the air is restricted. If the air flow is restricted it will cause serious damage to the generator or engine and may cause injury to people. Remember the generator's engine gives off **DEADLY** carbon monoxide gas.

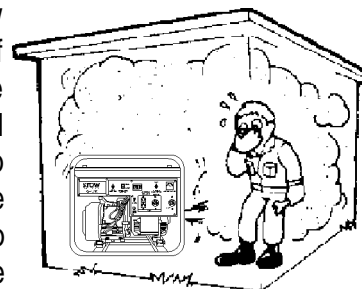

■ **ALWAYS** refuel in a well-ventilated area, away from sparks and open flames.

■ **ALWAYS** use extreme caution when working with **flammable** liquids. When refueling, **stop the engine** and allow it to cool. **DO NOT smoke** around or near the machine. Fire or explosion could result from fuel vapors, or if fuel is spilled on a hot engine.



■ **NEVER** operate the generator in an explosive atmosphere or near combustible materials. An explosion or fire could result causing severe **bodily harm or even death**.



■ **NEVER** disconnect any "**emergency or safety devices**". These devices are intended for operator safety. Disconnection of these devices can cause severe injury, bodily harm or even death! Disconnection of any of these devices will void all warranties.

STOW G-4.5R — RULES FOR SAFE OPERATION

- **ALWAYS** be sure the operator is familiar with proper safety precautions and operation techniques before using generator.
- **NEVER** leave the generator unattended, turn off engine when unattended.
- Unauthorized equipment modifications will void all warranties.
- **ALWAYS** ensure generator is on level ground before use.
- **DO NOT** place hands or fingers inside generator engine compartment when engine is running.
- **NEVER** run engine without air cleaner. Severe engine damage may occur.
- **NEVER** change or adjust the engine speed which has been set at the factory prior to shipping.



Power Cord Safety

- **NEVER** let power cables or cords *lay in water*.
- **NEVER** *stand in water* while AC power from the generator is being transfer to a load.
- **NEVER** use a defective or frayed power cable. Check the cable for cuts in the insulation.
- **NEVER** use a extension cord that is frayed or damaged where the insulation has been cut.
- **ALWAYS** make certain that proper power or extension cord has been selected for the job See Table 4.

Grounding Safety

- **ALWAYS** make sure that electrical circuits are properly *grounded* per the **National Electrical Code** (NEC) and local codes before operating generator. Severe *injury* or *death!* by electrocution can result from operating an ungrounded generator.
- **ALWAYS** make sure generator is properly grounded to a suitable earth ground (**GROUND ROD**). See installation section in this manual.
- **NEVER** use *gas piping* as an electrical ground.

Maintenance Safety

- **NEVER** lubricate components or attempt service on a running machine.
- **High Temperatures** – Always stop engine and allow the engine to cool before adding fuel, oil or performing service and maintenance functions. Contact with **hot!** components can cause serious burns. 
- Keep the machinery in proper running condition.
- Fix damage to the machine immediately and replace any broken parts immediately.
- **ALWAYS** replace any worn or damaged warning decals.
- **ALWAYS** store equipment properly when it is not being used. Equipment should be stored in a clean, dry location out of the reach of children and un-authorized personnel.
- The electrical voltage required to operate the generator can cause severe injury or even death through physical contact with live circuits. Turn all circuit breakers **OFF** before performing maintenance on the generator.
- Dispose of hazardous waste properly. Examples of potentially hazardous waste are used motor oil, fuel and fuel filters.
- **DO NOT** use food or plastic containers to dispose of hazardous waste.
- **DO NOT** pour waste, oil or fuel directly onto the ground, down a drain or into any water source.
- Removing the engine oil drain plug while the engine is hot will result in hot oil to gush out of the oil drain plug, therefore causing severe scalding to any persons in the general area of the generator. 

STOW G-4.5R — RULES FOR SAFE OPERATION

DANGER-ELECTROCUTION HAZARDS

During operation of this generator, there exists the possibility of **electrocution, electrical shock or burn**, which can cause **severe bodily harm** or even **DEATH!**



To avoid these hazards:

NEVER use **damaged** or **worn** cables when connecting equipment to the generator. Make sure power connecting cables are securely connected to the generator's output receptacles, incorrect connections may cause damage to the generator and electrical shock.

NEVER grab or touch a live power cord with wet hands, the possibility exist of electrical shock, electrocution, and even **death!**

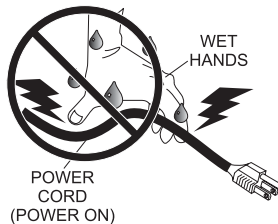

NEVER insert any objects into the output receptacles during operation. This is extremely dangerous. **ALWAYS** turn-off the generator and place all circuit breakers in the "OFF" position when contact with the output receptacles is required. There exist the possibility of **electrocution, electrical shock or burn, which can cause severe bodily harm or even death!**

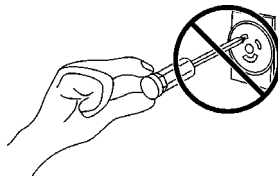

Backfeed to a utility system can cause **electrocution** and or property damage. **NEVER** connect the generator to a building's electrical system without a transfer switch or other approved device. All installations should be performed by a **licensed electrician** in accordance with all applicable laws and electrical codes. Failure to do so could result in electrical shock or burn causing serious injury or even death!

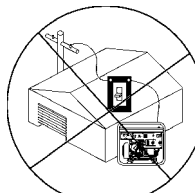

Emergencies

■ **ALWAYS** know the location of the nearest **fire extinguisher**.

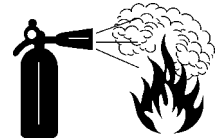

■ **ALWAYS** know the location of the nearest **first aid kit**.



■ In emergencies **always** know the location of the nearest phone or **keep a phone on the job site**. Also know the phone numbers of the nearest **ambulance, doctor** and **fire department**. This information will be invaluable in the case of an emergency.

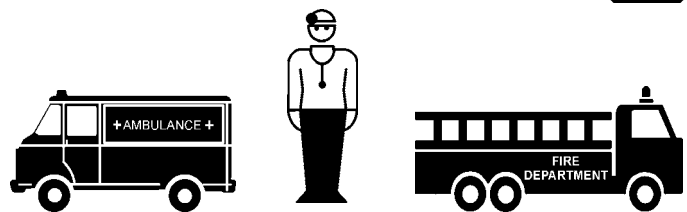

OPERATION AND SAFETY DECALS (S/N 5498030 AND BELOW)

Machine Safety Decals

The G-4.5R portable generator is equipped with a number of safety decals (Figures 2A and 2B). These decals are provided for operator safety and maintenance information. The illustration below shows these decals as they appear on the machine. Should any of these decals become unreadable, replacements can be obtained from your dealer.



P/N A3562000003

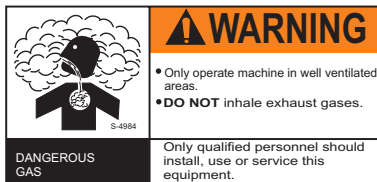

P/N 8700611804



P/N 1980680004



CONTACT
STOW PARTS DEPT.



P/N 8700611904

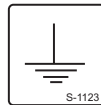

P/N 0800628504

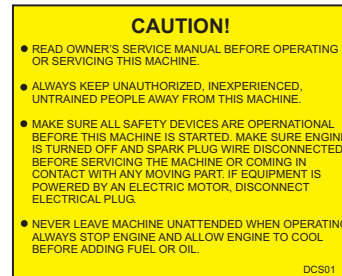

P/N 0820610304



P/N 7900636004

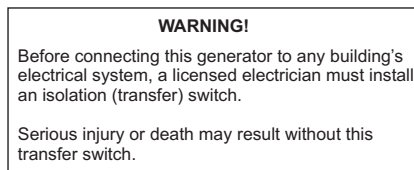

P/N 0820610404

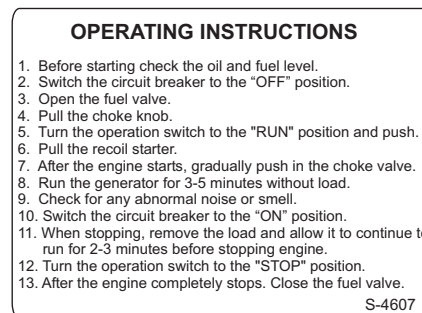

P/N 7900638204

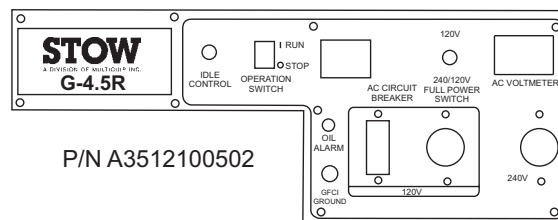

P/N A3512100502

Figure 2A. Operation and Safety Decals (S/N 5498030 and Below)

OPERATION AND SAFETY DECALS (S/N 5498031 AND ABOVE)



P/N A4561000203



P/N 8700611804

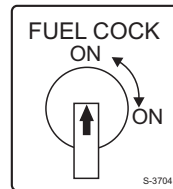

P/N 1980680004



CONTACT STOW PARTS DEPT.



P/N 8700611904

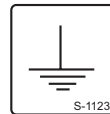

P/N 0800628504



P/N 35137



P/N 7900636004

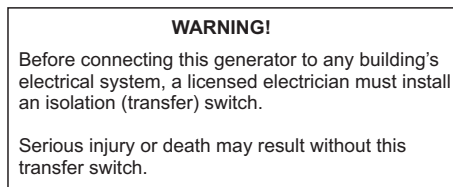

P/N 0820610404

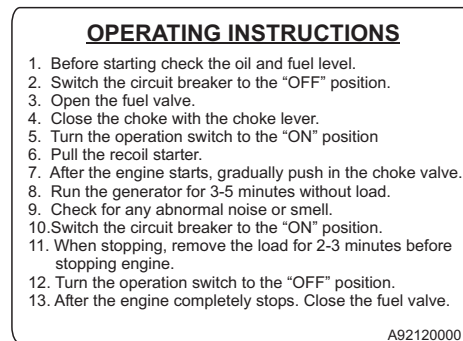

P/N A92120000

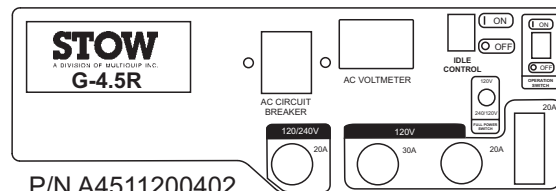

P/N A4511200402

Figure 2B. Operation and Safety Decals (S/N 5498031 and Above)

STOW G-4.5R — GENERAL INFORMATION

STOW G-4.5R Familiarization

General Inspection Prior to Operation

This generator has been thoroughly inspected and accepted prior to shipment from the factory. However, be sure to check for damaged parts or components, or loose nuts and bolts, which could have become dislodged in transit.

The **STOW Model G-4.5R** generator has been designed as a portable lightweight power source for 60 Hz (single-phase) vibrators, lighting facilities, power tools, submersible pumps and other industrial and construction machinery.

This generator is powered by a 9.0 HP **ROBIN** air-cooled gasoline engine. The alternator, a brushless revolving-field type, is permanently aligned to the engine through rigid coupling.

The generator is mounted on rubber vibration isolators that have a steel base backplate which is attached to the protective steel pipe carrying frame. The protective carrying frame is made of steel tubing and fully wraps around the generator to protect against damage.

This portable generator is supplied with a electrical **control panel**. The control panel includes items as listed below.

Control Panel

The generator control panel has the following components:

- NEMA 5-20R, GFCI duplex receptacle, (120V, 20 amps)
- NEMA L5-20R, twist-lock receptacle (125V, 20 amps)
- NEMA L5-30R, twist-lock receptacle (125V, 30 amps)
- NEMA L6-20R, twist-lock receptacle (250V, 20 amps), (S/N 5498030 and below)
- NEMA L14-20R, twist-lock receptacle (125/250V, 20 Amps), S/N 5498031 and above.
- Circuit breaker, 2-pole, 15 amps
- AC Voltmeter
- Operation Switch
- Idle Control Switch
- Full Power Switch
- Oil Alarm Lamp (S/N 5498030 and below)
- Ground Terminal (S/N 5498030 and below)

Circuit Breaker

To protect the generator from an overload, a 2-pole, 15 amp circuit breaker is provided on the control panel. Make sure to switch this circuit breaker to the "OFF" position prior to starting the engine.

Excitation System

The STOW G-4.5R generator uses a magnet attached to a flywheel to produce AC voltage from a lamp coil beneath the flywheel. As the magnet passes the coil it produces approximately 19-22 AC volts.

This voltage (19-22 VAC) is then sent to the control box that contains three rectifying diodes:

- Excitation (diode 1)
- Battery (diode 2)
- Slow Down (diode 3)

The AC voltage will pass through the excitation diode that converts the voltage to DC power.

This DC power is then sent to the excitation windings housed within the main windings commonly called the "stator".

This voltage is then transferred into the rotor through induction. The rotor contains two diodes within it which rectify the DC voltage and send it out through the main windings, as AC voltage.

Engine

The four-cycle air-cooled **ROBIN** gasoline engine is designed to meet every performance requirement of this generator. Reference Table 1, for engine specifications.

Figures 3A through 3D shows the basic controls and indicators for the G-4.5R generator.

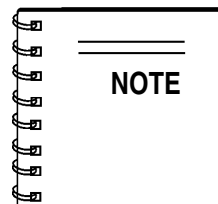

In keeping with **STOW's** policy of constantly improving its products, the specifications quoted herein are subject to change without prior notice.

STOW G-4.5R — LOAD APPLICATION

Single Phase Load

Always be sure to check the nameplate on the generator and equipment to insure the wattage, amperage and frequency requirements are satisfactorily supplied by the generator for operating the equipment.

Generally, the wattage listed on the nameplate of the equipment is its rated output. Equipment may require 130—150% more wattage than the rating on the nameplate, as the wattage is influenced by the efficiency, power factor and starting system of the equipment.



If wattage is not given on the equipment's name plate, approximate wattage may be determined by multiplying nameplate voltage by the nameplate amperage.

$$\text{WATTS} = \text{VOLTAGE} \times \text{AMPERAGE}$$

The power factor of this generator is 1.0 See Table 2 below when connecting loads.

Type Of Load	Power Factor
Single-phase induction motors	0.4 - 0.75
Electric heaters, incandescent lamps	1.0
Fluorescent lamps, mercury lamps	0.4 - 0.9
Electronic devices, communication equipment	1.0
Common power tools	0.8

To determine the running wattage for your load, multiply the running wattage as indicated by steps 1, 2, and 3 below:

1. **INCANDESCENT LOADS**
Lights, heaters and similar appliances.
Total the running wattage and multiply by 1.
Example:
29 light bulbs @ 100W each = 2.9 KW
use a 3 KW generator.
2. **SMALL MOTORS**
Drills and other small power tools.
Total the running wattage and multiply by 2.
Example:
A 1 inch drill runs at 1 KW
use a 2 KW generator.
3. **LARGE MOTORS**
Submersible pumps, table saws etc.
Total the running wattage and multiply by 3.
Example:
A conveyor belt runs at 8 KW
use a 24 KW generator.

CAUTION

Motors and motor-driven equipment draw much greater current for starting than during operation. **Always** use an adequate size **extension cable** which can carry the required load.

Extension Cables

When electric power is to be provided to various tools or loads at some **distance** from the generator, extension cords are normally used. **Cables should be sized to allow for distance in length and amperage so that the voltage drop between the generator and point of use (load) is held to a minimum.** Use the cable selection chart (Table 2) as a guide for selecting proper cable size.

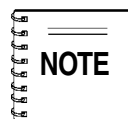

The idle control device is operated at a minimum load capacity of 100W. If the load capacity is less than 100W, place the idle control switch in the **OFF** position.



When using a combination of dual receptacles, total load **should not exceed** the rated capacity of the generator.

STOW G-4.5R — CONTROLS AND INDICATORS

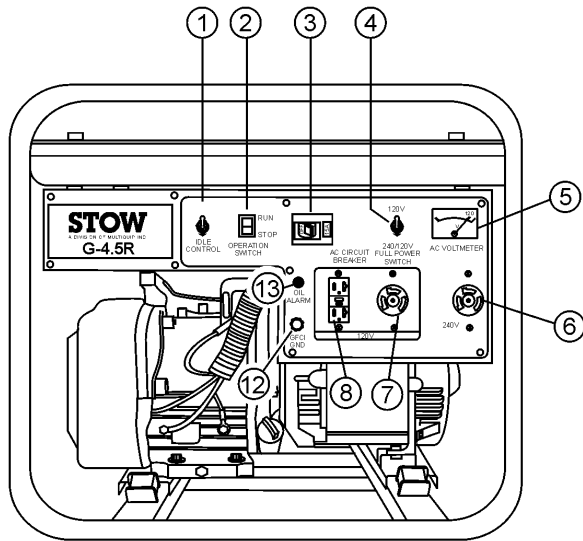

S/N5498030 AND BELOW

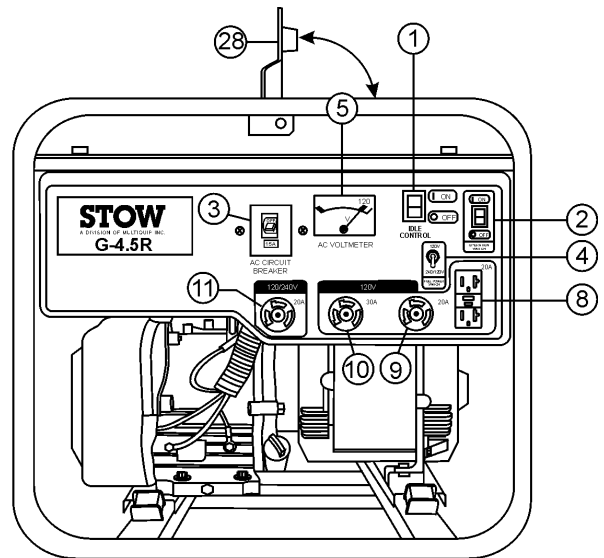

S/N5498031 AND ABOVE

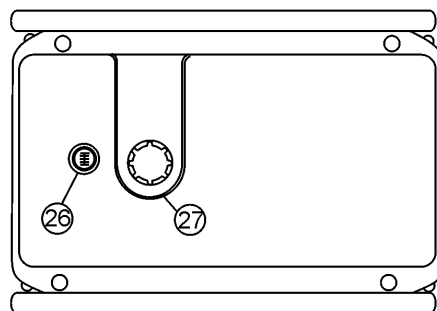
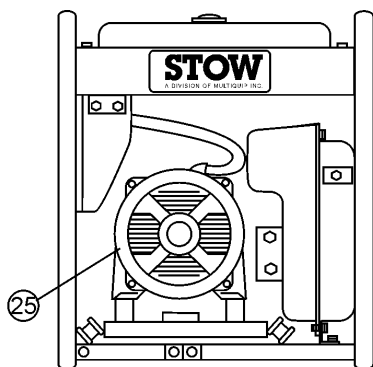
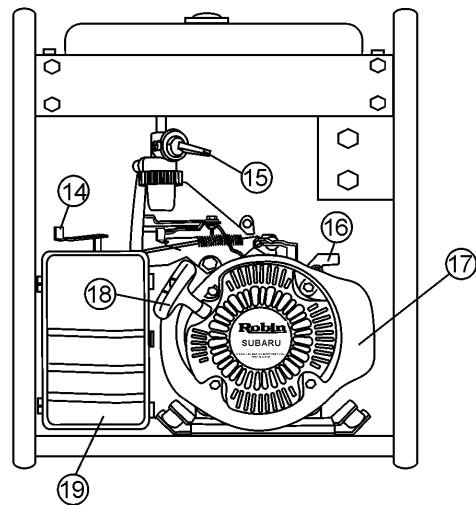
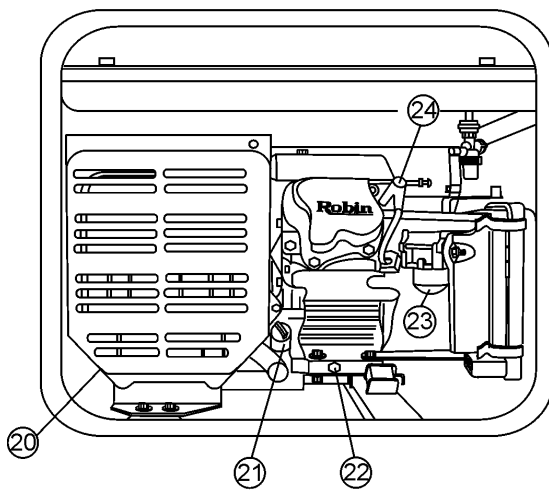

Figure 3A. Generator Controls and Components

STOW G-4.5R — CONTROLS AND INDICATORS

1. **Idle Control Switch** – This unit is provided with an automatic idle control for noise suppression and reduced fuel consumption. The automatic idle control automatically engages under a no-load condition. With the automatic idle control switched “ON”, the engine revolutions will automatically drop to about 2600 rpm (low-speed operation) within 3 seconds after the load stops. When the operation is resumed, the engine speed is automatically increased to about 3600 rpm (high-speed operation) as soon as the load is connected.
2. **Operation Switch** – Place this *rocker* switch in the "RUN" position (up) for normal operation. To turn-off the generator place this switch in the "STOP" position (down).
3. **Main Circuit Breaker** – This 2-pole 15 amp breaker protects the generator from short circuiting or overloading. When starting the generator *always* have the circuit breaker placed in the "OFF" position.
4. **Full Power Switch** – This generator is provided with a full power switch. Figures 3B and 3C show simplified wiring diagrams of the dual voltage system. When the full power switch is in the 120 volt (up) position, you can take up **full rated power** of the generator at 120 volts from the GFCI duplex receptacle, 120 volts at the 120 volt twist-lock receptacle, or a combination of both receptacles as long as the total load does not exceed the generator's capacity.

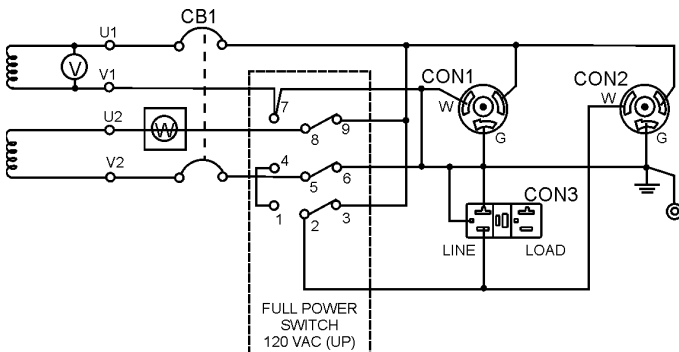

Figure 3B. Full Power Switch 120VAC (Up) Simplified Wiring Diagram

When the full power switch is in the 240 volt (down) position, you can take up to half of the rated power of the generator at 120 volts from the GFCI receptacle and up to half of the rated power of the generator at 120 volts from the twist-lock 120 volt receptacle; or full rated power of the generator at 240 volts from the twist-lock 240 volt receptacle.

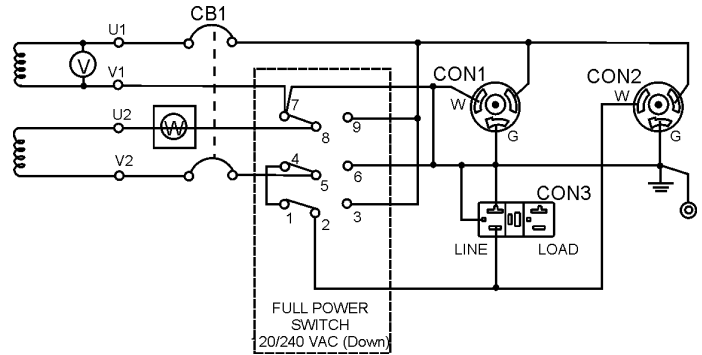
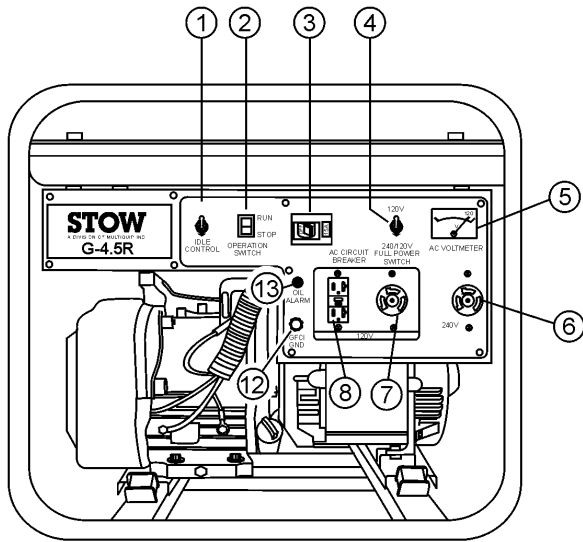

Figure 3C. Full Power Switch 120/240 VAC (Down) Simplified Wiring Diagram

NOTE When the full **power switch** is in the 120 volt position, the 240V receptacle cannot be used.

5. **AC-Voltmeter** – This voltmeter indicates (with a mark) the rated 60 Hz, single phase output voltage. In addition the voltmeter can also be used as a diagnostic tool. If the voltmeter indicator (needle) is below the rated voltage, engine problems may exist (low/high RPM's). To prevent damage to the generator or power tools turn the generator **OFF** and consult your authorized **STOW** service dealer.
6. **240 VAC Receptacle, 20 Amps** – This receptacle will provide 240V when the full power switch is placed in the 240/120 volt position (down). Applies to units with S/N 5498030 and below.
7. **120 VAC Receptacle, 30 Amps** – This receptacle will provide 120V when the full power switch is placed in either the 120 or 240 volt position. Applies to units with S/N 5498030 and below.
8. **GFCI Receptacle, 20 Amps** – This receptacle will provide 120V at all times no matter the position of the full power switch. Applies to all units.
9. **120 VAC Receptacle, 30 Amps** – This receptacle will provide 120V when the full power switch is placed in either the 120 or 240 volt position. Applies to units with S/N 5498031 and above.
10. **120 VAC Receptacle, 20 Amps** – This receptacle will provide 120V when the full power switch is placed in either the 120 or 240 volt position. Applies to units with S/N 5498031 and above.
11. **240 VAC Receptacle, 20 Amps** – This receptacle will provide 240V when the full power switch is placed in the 240/120 volt position (down). Applies to units with S/N 5498031 and above

STOW G-4.5R — CONTROLS AND INDICATORS



S/N5498030 AND BELOW

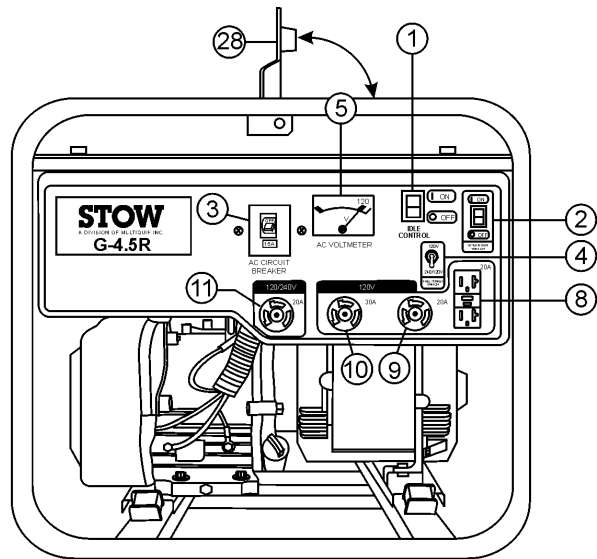

S/N5498031 AND ABOVE

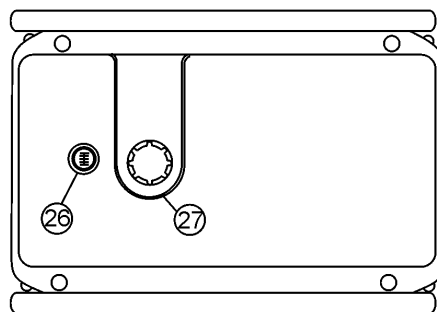
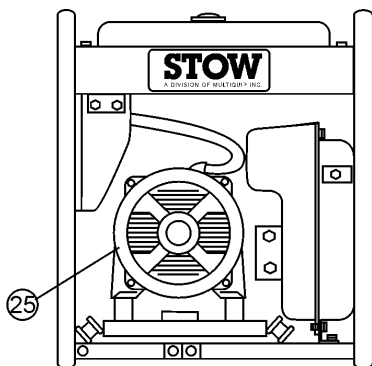
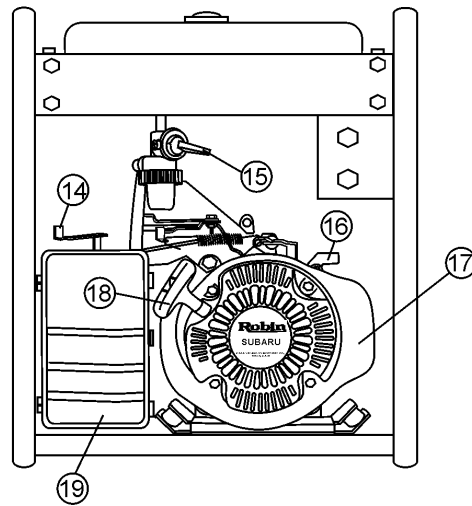
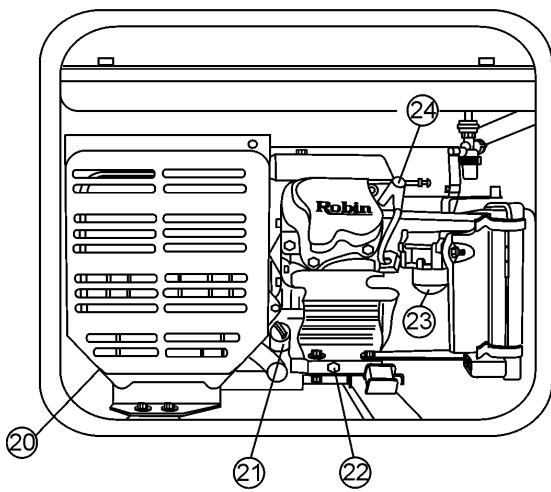
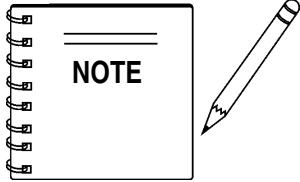

Figure 3D. Generator Controls and Components (continued)

STOW G-4.5R — CONTROLS AND INDICATORS

12. **GFCI Ground** – This ground connection point should be connect to a good earth ground (ground rod).
13. **Oil Alarm Indicator** – This indicator will light in the event of low oil. Applies to units with S/N 5498030 and below.



This **ROBIN** engine is equipped with a low oil shutdown capability. A built in sensor will automatically turn off the engine should the oil level fall below a safe operating condition. Make sure the generator is placed on level

ground. Placing the generator on level ground will ensure that the low oil sensor will function properly.

14. **Choke Lever** – Used for starting the engine. **Close** the choke lever when starting a cold engine or in cold weather conditions. The choke enriches the fuel mixture. **Open** the choke lever if starting a warm engine or in warm weather conditions.
15. **Fuel Cock Lever** – Turn this lever **downward** to **start** (down) the flow of fuel to the carburetor. Turn **upward** to **stop** (up) the flow of fuel.
16. **Throttle Lever** – Used to adjust engine RPM speed. This unit is set at the factory and is not adjustable.
17. **Engine** – This generator uses a 9.0 HP **ROBIN** air-cooled, 4-stroke, single cylinder, overhead camshaft gasoline engine. Engine uses unleaded fuel.
18. **Recoil Starter (Pull Rope)** – Used for manual-starting of the engine. Pull the starter grip until resistance is felt, then pull briskly and smoothly.
19. **Air Cleaner** – Prevents dirt and other debris from entering the fuel system. Remove wing-nut on top of air filter cannister to gain access to filter element. **NEVER** run the engine without an air cleaner.
20. **Muffler/Heat Shield** – Used to reduce noise and emissions. **NEVER** touch this **heat shield** when the generator is in use. Always allow time for the generator to cool down before performing maintenance.
21. **Oil Dipstick/ Filler Cap** – Remove the filler cap dipstick when checking the engine oil level. Add engine oil through this filler port. See Table 4 for recommended type engine oil.
22. **Oil Drain Plug** – Remove this plug to drain engine oil from the crankcase.
23. **Spark Plug** – Provides spark to the ignition system. Set spark plug gap to 0.6 - 0.7 mm (0.024 - 0.028 inch). Clean spark plug once a week
24. **Carburetor Fuel Cup** – Inspect the fuel cup weekly for water and dirt. Clean as referenced in the maintenance section of this manual.
25. **Generator Housing** – Contains the rotor, rectifier field coil assembly, armature, bearings and other components that make up generator assembly.
26. **Fuel Gauge** – Read this gauge to determine when fuel is **low**.
27. **Fuel Gauge/Tank** – Remove this cap to add unleaded gasoline to the fuel tank. **Replenish** with **clean unleaded** gasoline. Make sure cap is tightened securely. **DO NOT** over fill. Fuel tank capacity is 5 gallons (19 liters).
28. **Lifting Bail Eye** – Attach a rope or chain to this lifting eye when lifting of the generator is required. Never stand underneath the generator while it is being lifted. Place lifting eye in down position when not in use. Applies to units with S/N 5498031 and above.

STOW G-4.5R — GENERATOR REFUELING

DANGER

Adding fuel to the tank should be done only when the engine is stopped and has had an opportunity to cool down. In the event of a fuel spill, **DO NOT** attempt to start the engine until the fuel residue has been completely wiped up, and the area surrounding the engine is dry. If generator is placed in a truck bed with a plastic liner, **REMOVE** generator from truck bed and place on ground (Figure 4) to refuel. This possibility exist of **fire** or **explosion** due to static electricity.

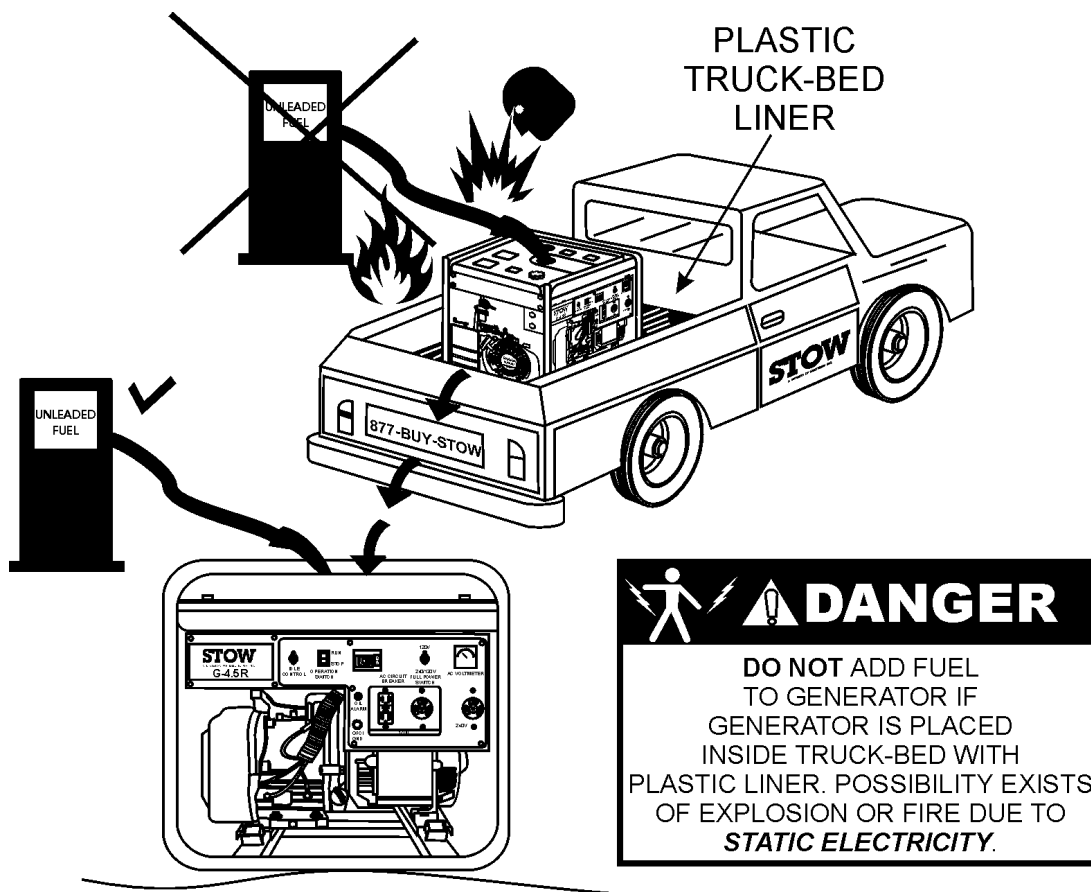



Figure 4. Generator Refueling

Outdoor Installation

Install the generator in a area that is free of **debris**, **bystanders**, and **overhead obstructions**. Make sure the generator is on secure level ground so that it cannot slide or shift around. Also install the generator in a manner so that the exhaust will not be discharged in the direction of nearby homes.

The installation site must be relatively free from moisture and dust. All electrical equipment should be protected from excessive moisture. Failure to do will result in deterioration of the insulation and will result in short circuits and grounding.

Foreign materials such as dust, sand, lint and abrasive materials have a tendency to cause excessive wear to engine and alternator parts.

 CAUTION	
Pay close attention to ventilation when operating the generator inside tunnels and caves. The engine exhaust contains noxious elements.	

Mounting

The generator should always be mounted on a flat level surface to isolate vibration of the generator when it is running. **DO NOT** place the generator on slopes, the possibility exists that the generator could slide.

Indoor Installation

Exhaust gases from gasoline engines are extremely poisonous. Whenever an engine is installed indoors the exhaust fumes must be vented to the outside. The engine should be installed at least two feet from any outside wall. Using an exhaust pipe which is too long or too small can cause excessive back pressure which will cause the engine to heat excessively and possibly burn the valves.

Eliminate the danger of deadly carbon monoxide gas. Remember that exhaust fumes from any gasoline engine are very poisonous if discharged in a closed room, but harmless if allowed to mix with the outside air. If the generator is installed indoors, you must make provisions for venting the engine exhaust to the outside of the building.

Generator Grounding

To guard against electrical shock and possible damage to the equipment, it is important to provide a good **EARTH** ground. Always use the ground terminal on the generator to ground the generator.

Article 250 (Grounding) of the National Electrical Code (NEC) provides guide lines for proper grounding and specifies that the cable ground shall be connected to the grounding system of the building as close to the point of cable entry as practical.

NEC articles 250-64(b) and 250-66 set the following grounding requirements:

1. Use one of the following wire types to connect the generator to earth ground.
 - a. Copper - 10 AWG (5.3 mm²) or larger.
 - b. Aluminum - 8 AWG (8.4 mm²) or larger.
2. When grounding the generator (Figure 3) connect the ground cable between the lock washer and the nut on the generator and tighten the nut fully. Connect the other end of the ground cable to earth ground.
3. NEC article 250-52(c) specifies that the earth ground rod should be buried a minimum of 8 ft. into the ground.

STOW G-4.5R — INSTALLATION

Connecting the Ground

The nut and ground terminal on the generator should always be used to connect the generator to a suitable ground. The ground cable should be #8 size wire minimum.

At the generator, connect the terminal of the ground cable between the lock washer and the nut (Figure 5) and tighten the nut fully. Connect the other end of the ground cable to a suitable earth ground (ground rod).

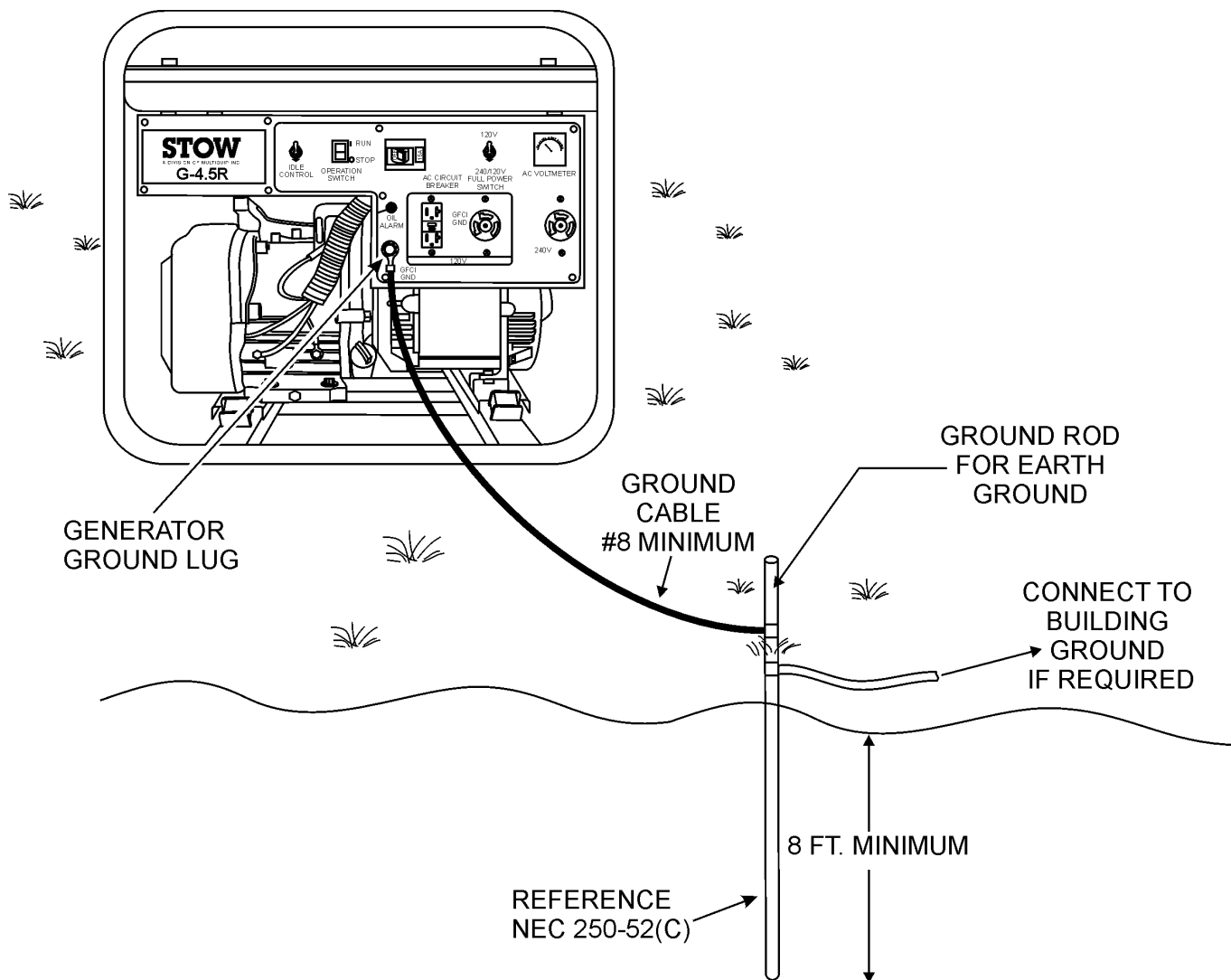

Figure 5. Generator Grounding

General Inspection Prior to Operation

Ground Power Tools

When using power tools or electrical equipment requiring AC power from the generator, make sure connecting (power tool) cable (Figure 6) has a ground as shown in Figure.

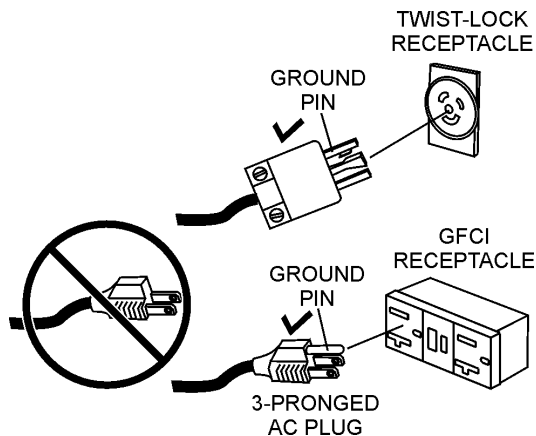
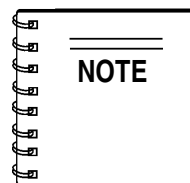

Figure 6. Ground Cables/Plugs

Extension Cable

When electric power is to be provided to various tools or loads at some distance from the generator, extension cords are normally used. Cables should be sized to allow for distance in length and amperage so that the voltage drop between the generator and point of use (load) is held to a minimum. Use the cable selection chart (Table 3) as a guide for selecting proper cable size.



Never! use power tools or equipment that do not have a ground capability, the possibility exists of **electrocution, electrical shock or burn**, which can cause **severe bodily harm** or even **DEATH!**

Main Circuit Breaker

To protect the generator from an overload always place the main circuit breaker in the "OFF" position prior to starting the engine.

Table 3. Cable Selection (60 Hz, Single Phase Operation)

Current in Amperes	Load In Watts	Maximum Allowable Cable Length				
		At 120 Volts	#10 Wire	#12 Wire	#14 Wire	#16 Wire
2.5	300		1000 ft.	600 ft.	375 ft.	250 ft.
5	600		500 ft.	300 ft.	200 ft.	125 ft.
7.5	900		350 ft.	200 ft.	125 ft.	100 ft.
10	1200		250 ft.	150 ft.	100 ft.	
15	1800		150 ft.	100 ft.	65 ft.	
20	2400		125 ft.	75 ft.	50 ft.	

CAUTION: Equipment damage can result from low voltage.

STOW G-4.5R — PRE-INSPECTION (ENGINE)

CAUTION

NEVER operate the generator in a confined area or enclosed area structure that does not provide ample **free flow of air**.



ALWAYS wear approved eye and hearing protection before operating the generator.

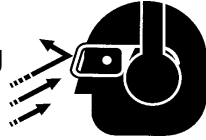

Before Starting

1. Read safety instructions at the beginning of manual.
2. Clean the generator, removing dirt and dust, particularly the engine cooling air inlet, carburetor and air cleaner.
3. Check the air filter for dirt and dust. If air filter is dirty, replace air filter with a new one as required.
4. Check carburetor for external dirt and dust. Clean with dry compressed air.
5. Check fastening nuts and bolts for tightness.



Engine Oil Check

1. To check the engine oil level, place the generator on secure level ground with the engine stopped.
2. Remove the filler dipstick from the engine oil filler hole (Figure 7) and wipe clean.

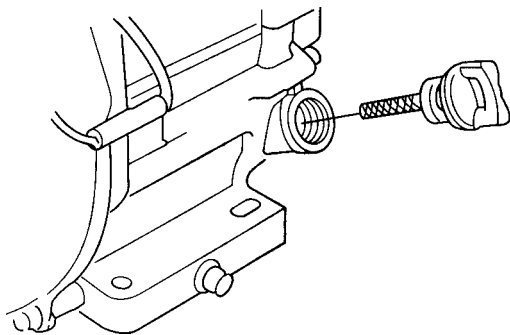

Figure 7. Engine Oil Dipstick (Removal)

3. Insert and remove the dipstick without screwing it into the filler neck. Check the oil level shown on the dipstick.
4. If the oil level is low (Figure 8), fill to the edge of the oil filler hole with the recommended oil type (Table 4). Maximum oil capacity is 1.16 quarts (1.1 liters)

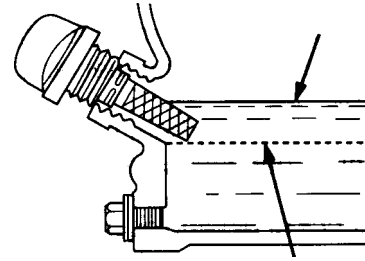

Figure 8. Engine Oil Dipstick (Oil Level)

Table 4. Oil Type

Season	Temperature	Oil Type
Summer	25°C or Higher	SAE 10W-30
Spring/Fall	25°C~10°C	SAE 10W-30/20
Winter	0°C or Lower	SAE 10W-10

DANGER EXPLOSIVE FUEL

Motor fuels are highly flammable and can be dangerous if mishandled. **DO NOT** smoke while refueling. **DO NOT** attempt to refuel the generator if the engine is **hot!**, **running or in the dark**.



Fuel Check

1. Close the fuel cock before filling the fuel tank.
2. Remove the fuel cap located on top of fuel tank.
3. Read the fuel gauge located on top of the fuel tank (Figure 9) to determine if the fuel level is low. If fuel is low, replenish with **clean unleaded fuel**.

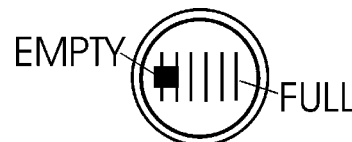

Figure 9. Fuel Gauge

4. When refueling, be sure to use a strainer for filtration. **DO NOT** top-off fuel. **DO NOT** fill the tank beyond capacity. Wipe up any spilled fuel **immediately!**

STOW G-4.5R — INITIAL START-UP (ENGINE)

CAUTION

DO NOT attempt to operate this generator until the Safety, General Information and Inspection sections of this manual have been **read and thoroughly understood**.



DO NOT attempt to operate this generator until the Safety, General Information and Inspection sections of this manual have been **read and thoroughly understood**.

This section is intended to assist the operator with the **initial start-up** of the trash generator. It is extremely important that this section be read carefully before attempting to use the generator in the field.

Before Starting the Engine

1. Be sure to **disconnect all electrical loads** from the generator prior to starting the engine.
2. **NEVER start** the engine with the **main circuit breaker** in the "ON" position. Place the main circuit breaker (Figure 10) in the **OFF** position.

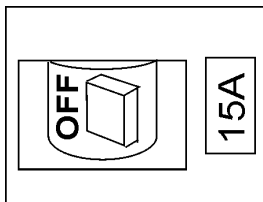

Figure 10. Main Breaker (OFF Position)

Starting the Engine

1. Place the engine **fuel valve lever** (Figure 11) to the "ON" position."

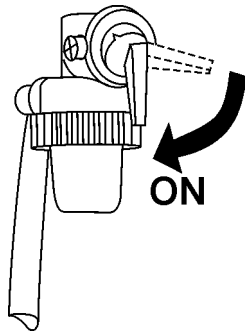

Figure 11. Engine Fuel Valve Lever (ON Position)

2. Place the **choke lever** (Figure 12) in the "**CLOSED**" position if starting a **cold** engine.

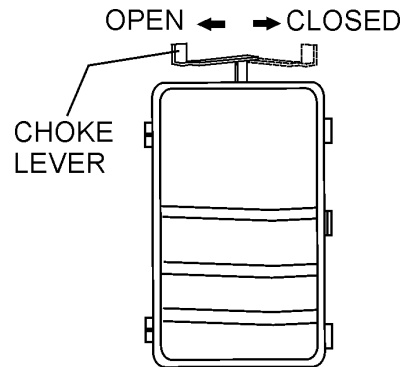
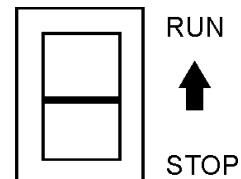

Figure 12. Choke Lever

3. Place the **choke lever** (Figure 12) in the "**OPEN**" position if starting a **warm engine** or the **temperature is warm**.
4. Place the **operation switch** (Figure 13) in the "**RUN**" position.



OPERATION SWITCH

Figure 13. Operation Switch (RUN)

5. Grasp the starter grip (Figure 14) and slowly pull it out. The resistance becomes the hardest at a certain position, corresponding to the compression point. Pull the starter grip briskly and smoothly for starting.

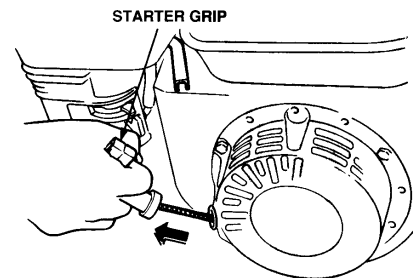

Figure 14. Starter Grip

CAUTION

DO NOT pull the starter rope all the way to the end.
DO NOT release the starter knob after pulling. Allow it to rewind as soon as possible.

STOW G-4.5R — INITIAL START-UP ENGINE/OPERATION

- If the engine has started, slowly return the choke lever (Figure 12) to the **"OPEN"** position. If the engine has not started repeat steps 1 through 6.
- Before the generator is placed into operation, run the engine for 3-5 minutes. Check for abnormal smells, fuel leaks, and noises that would associate with loose components.
- Place** the **idle control switch** (Figure 15) in the **"OFF"** (down) position. This will allow the engine run at speed about 3600 RPM's

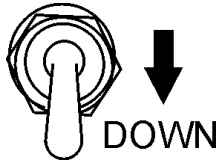
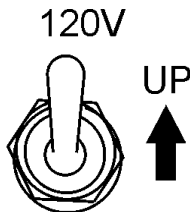

Figure 15. Idle Control Switch (Down)

NOTE Placing the **idle control switch** in the down position allows the engine to operate at a maximum speed of about 3600 RPM's. When the idle control switch is place in the up position (**ON**), the generator will run at idle speed (2200 RPM's) until a load is applied, at that time the engine speed will increase to 3600 RPM's as long as the load is being applied. When the load is not in use, the engine speed will drop back to the idle mode after about 3 seconds.

- Place** the **full power switch** (Figure 16) in the **"120V"** (Up) position.



240/120V

Figure 16. Full Power Switch (Up)

- Refer to the AC voltmeter (Figure 17) on the control box. The voltage indicated on the voltmeter should be 120 VAC with no load applied.

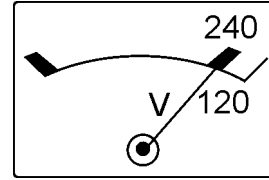

Figure 17. AC Voltmeter (120VAC)

- If desired, verify with a voltmeter (Figure18) that 120 VAC is present at the GFCI receptacle and the twis-lock receptacles as shown below.

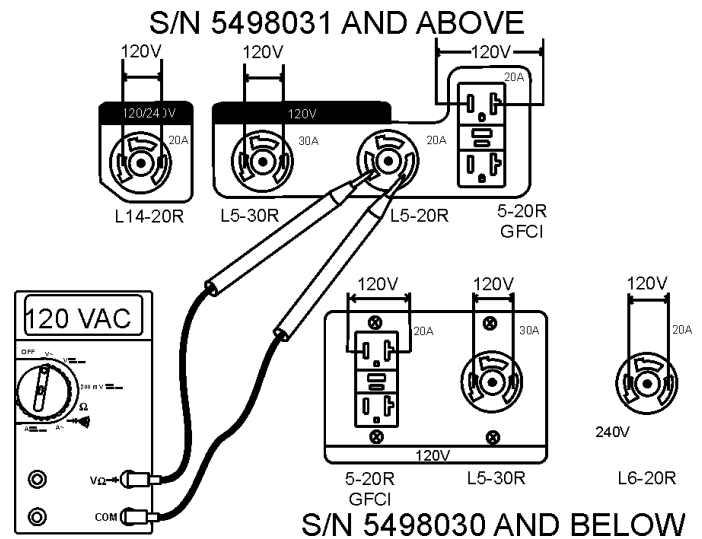

Figure 18. 120 VAC Receptacles

NOTE The **240V receptacle** on either unit is not operational (no voltage) when the full power switch is in the 120V position. This receptacle is active (voltage) only when the full power switch is in the 240V position.

- Place** the **full power switch** (Figure 19) in the **"240/120V"** (Down) position.

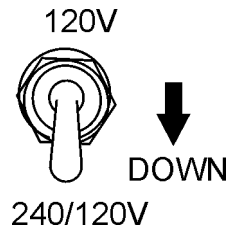

Figure 19. Full Power Switch (Down)

STOW G-4.5R — INITIAL START-UP ENGINE/OPERATION

- Refer to the AC voltmeter (Figure 20) on the control box. The voltage indicated on the voltmeter should be 240 VAC with no load applied. If desired, verify with a voltmeter that 240V is present at the NEMA L6-20R (S/N 5498030 and below) and the NEMA L14-20R (S/N 5498031 and above) twist-lock receptacles. In addition verify that 120 VAC is present at all other twist-lock receptacles on either unit.

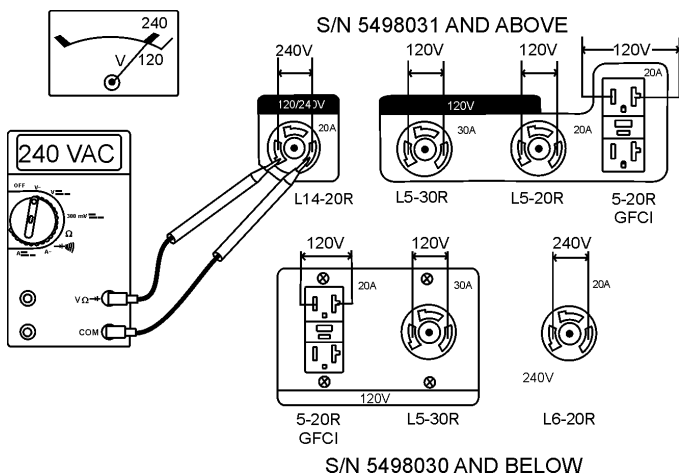
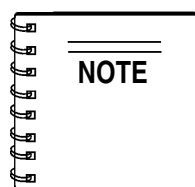

Figure 20. 240/120 VAC Receptacles



When the **full power switch** is in the 240V (down) position, up to half of the rated power of the generator is available at the 120V duplex receptacle or any twist-lock receptacle on either

unit; or full rated power can be obtained at the 240V receptacle. Remember, when using a combination of dual receptacles, **total load should not exceed the rated capacity of the generator.**

Connecting the Load

- Connect the load to the desired voltage output receptacle.
- Place the idle control switch (Figure 21) in the **ON** position (Up).

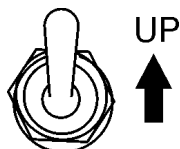

Figure 21. Idle Control Switch (Up)

- Place the main circuit breaker (Figure 22) in the **ON** position.

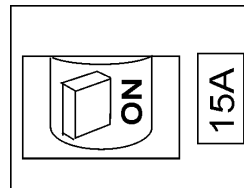

Figure 22. Main Circuit Breaker (ON)

Stopping The Engine

Normal Shutdown

- Place the **main circuit breaker** (Figure 11) in the **OFF** position.
- Remove the load from the generator, and let the engine run at idle for 3-5 minutes with the idle control switch in the **ON** position (Up)
- Place the **operation switch** (Figure 23) in the **STOP** position.

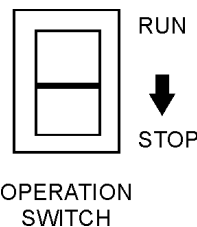

Figure 23. Operation Switch (Stop)

- Place the engine **fuel valve lever** (Figure 24) to the "OFF" position."

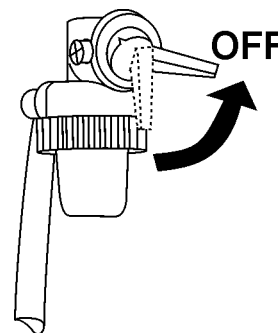

Figure 24. Engine Fuel Valve Lever (OFF Position)

Emergency Showdown

- Place the **operation switch** (Figure 23) in the **STOP** position.

STOW G-4.5R — PREPARATION FOR LONG -TERM STORAGE

Generator Storage

For storage of the generating set for over 30 days, the following is required:

- Drain the fuel tank completely, or add STA-BIL to the fuel.
- Run the engine until the gasoline in the carburetor is completely consumed.
- Completely drain the oil from the crankcase and refill with fresh oil.
- Remove the spark plug, pour 2 or 3 cc of SAE 30 oil into the cylinder and crank slowly to distribute the oil.
- Slowly rotate the engine a few times with the starter Rope and install a new plug.
- Pull out the starter rope slowly and stop at the compression point.
- Clean all external parts of the generating set with a cloth.
- Cover the generating set and store in a clean, dry place.

STOW G-4.5R — MAINTENANCE (ENGINE)

Use Table 5 as a general maintenance guideline when servicing your engine. For more detail engine maintenance information, refer to the engine owner's manual supplied with your engine.

Table 5. Engine Maintenance Schedule							
DESCRIPTION (3)	OPERATION	BEFORE	FIRST MONTH OR 10 HRS.	EVERY 3 MONTHS OR 25 HRS.	EVERY 6 MONTHS OR 50 HRS.	EVERY YEAR OR 100 HRS.	EVERY 2 YEARS OR 200 HRS.
Engine Oil	CHECK	X					
	CHANGE		X				
Air Cleaner	CHECK	X					
	CHANGE			X (1)			
All Nuts & Bolts	Re-tighten If Necessary	X					
Spark Plug	CHECK-CLEAN				X		
	REPLACE						X
Cooling Fins	CHECK				X		
Spark Arrester	CLEAN					X	
Fuel Tank	CLEAN					X	
Fuel Filter	CHECK					X	
Idle Speed	CHECK-ADJUST					X (2)	
Valve Clearance	CHECK-ADJUST						X (2)
Fuel lines	CHECK	Every 2 years (replace if necessary) (2)					

(1) Service more frequently when used in **DUSTY** areas.

(2) These items should be serviced by your service dealer, unless you have the proper tools and are mechanically proficient. Refer to the ROBIN Shop Manual for service procedures.

(3) For commercial use, log hours of operation to determine proper maintenance intervals.

STOW G-4.5R — MAINTENANCE (ENGINE)

Maintenance

Perform the scheduled maintenance procedures as defined by Table 6 and below:

DAILY

- Thoroughly remove dirt and oil from the engine and control area. Clean or replace the air cleaner elements as necessary. Check and retighten all fasteners as necessary. Check the gearbox for oil leaks. Repair or replace as needed.

WEEKLY

- Remove the fuel filter cap and clean the inside of the fuel tank.
- Remove or clean the filter at the bottom of the tank.
- Remove and clean the spark plug (Figure 25), then adjust the spark gap to 0.024 ~0.028 inch (0.6~0.7 mm). This unit has electronic ignition, which requires no adjustments.

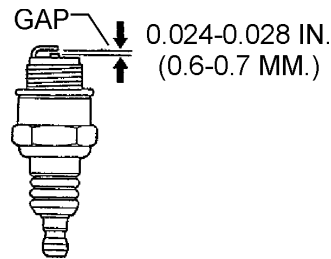

Figure 25. Spark Plug Gap

ENGINE OIL

- Drain the engine oil when the oil is **warm** as shown in Figure 26.
- Remove the oil drain bolt and sealing washer and allow the oil to drain into a suitable container.
- Replace engine oil with recommended type oil as listed in Table 4. For engine oil capacity, see Table 1 (engine specifications). **DO NOT** overfill.
- Install drain bolt with sealing washer and tighten securely.

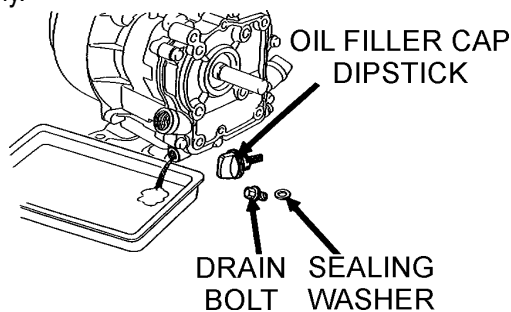

Figure 26. Engine Oil (Draining)

Cleaning the Fuel Strainer

Clean the fuel strainer if it contains dust or water. Remove dust or water in the strainer cap and wash it in gasoline. Securely fasten the fuel strainer cap so that fuel will not leak. Check the fuel strainer every 200 hours of operation or once a month.

! DANGER

DO NOT use gasoline as a cleaning solvent, because that would create a risk of fire or explosion.

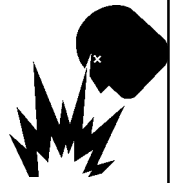

ENGINE AIR CLEANER

- Remove the air cleaner cover and foam filter element as shown in Figure 27.
- Tap the paper filter element (Figure 27) several times on a hard surface to remove dirt, or blow compressed air [not exceeding 30 psi (207 kPa, 2.1 kgf/cm²)] through the filter element from the air cleaner case side. **NEVER** brush off dirt. Brushing will force dirt into the fibers. Replace the paper filter element if it is excessively dirty.

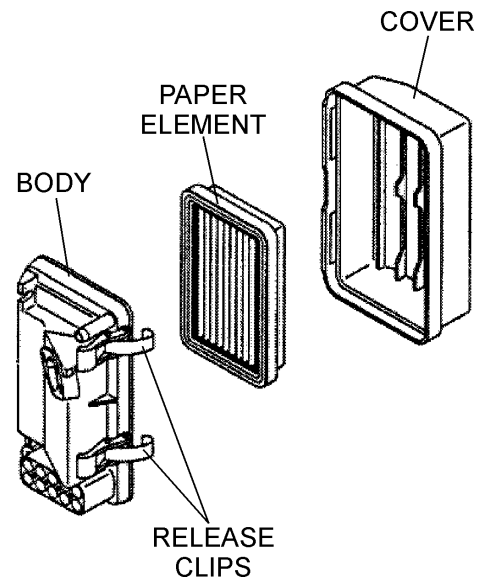

Figure 27. Engine Air Cleaner

STOW G-4.5R — WIRING DIAGRAM (S/N 5498030 AND BELOW)

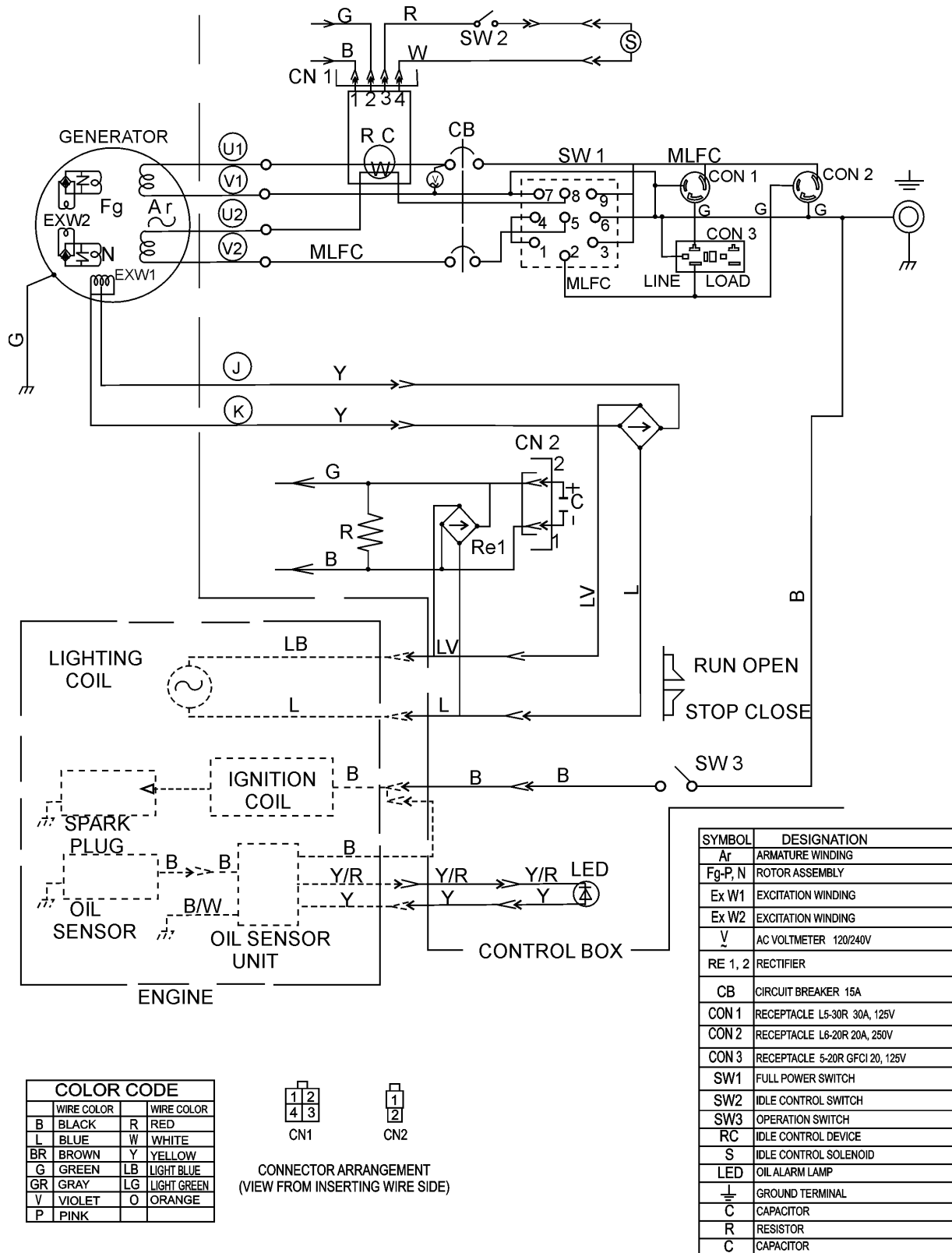

Figure 28. Generator/Engine Wiring Diagram (S/N 5498030 and Below)

STOW G-4.5R — WIRING DIAGRAM (S/N 5498031 AND ABOVE)

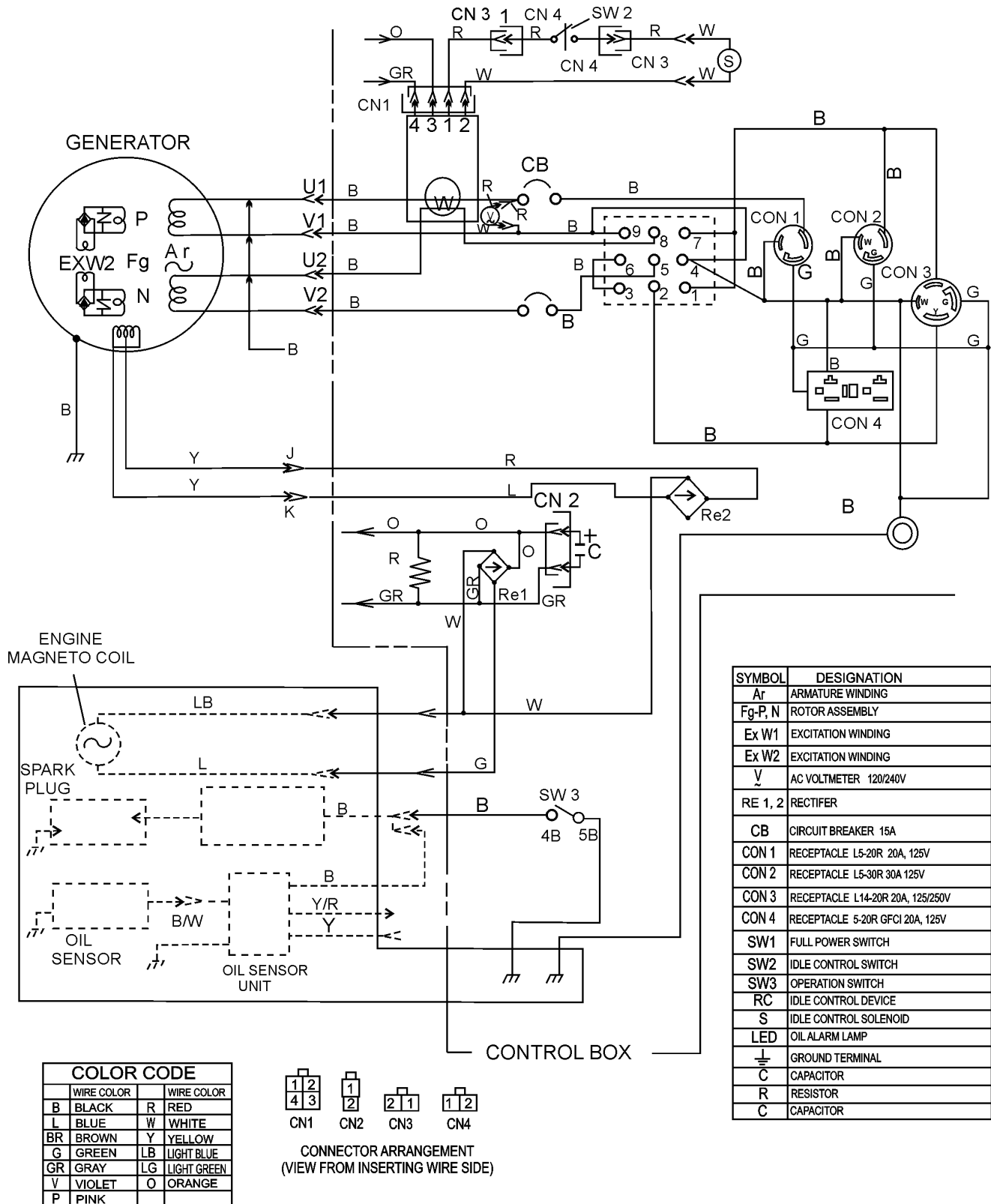

Figure 29. Generator/Engine Wiring Diagram (S/N 5498031 and Above)

STOW G-4.5R — TROUBLESHOOTING (ENGINE)

Practically all breakdowns can be prevented by proper handling and maintenance inspections, but in the event of a breakdown, please take a remedial action following the

diagnosis based on the Engine Troubleshooting (Table 6) information shown below and on the preceding page. If the problem cannot be remedied, please leave the unit just as it is and consult our company's business office or service plant.

TABLE 6. ENGINE TROUBLESHOOTING

SYMPTOM	POSSIBLE PROBLEM	SOLUTION
Poor starting	Inspect carburetor to see if fuel is reaching it?	Check fuel line
	No Fuel?	Add Fuel
	Water in fuel tank?	Flush or replace fuel tank.
	Fuel filter clogged?	Replace fuel filter
	Stuck carburetor?	Check float mechanism.
	Spark plug is red?	Spark plug is fouled. Check transistor ignition unit.
	Spark plug is blue-white?	Insufficient compression, injected air leaking. Carburetor jets are clogged (overflow).
	No spark present at tip of spark plug?	Transistor ignition unit broken, high voltage cord cracked or broken. Start/Stop switch broken. Replace spark plug if fouled.
	No oil?	Add oil as required.
	Oil pressure alarm lamp blinks upon starting?	Check Automatic shutdown circuit "oil sensor".
Insufficient power output "no compression"	Engine will not turn over?	Replace cylinder and piston and if necessary axel joint.
	Cylinder head connecting bolts loose?	Tighten cylinder head connecting bolts.
	Cylinder head gasket damaged?	Replace cylinder head gasket.
	Malfunction of valve seat?	Re-seat valves.
	Spark plug is loose?	Replace spark plug.
	Worn piston rings?	Replace piston rings.
Insufficient power output "compression"	Malfunction in air-cleaner system, air filter clogged?	Clean or replace air filter.
	Air leaking in from interface between carburetor and cylinder head?	Tighten bolts between carburetor and cylinder head. Replace cylinder head gasket.
	Malfunction in fuel system?	Clean or replace fuel filter. Clean or replace carburetor. Check carburetor float.

STOW G-4.5R — TROUBLESHOOTING (ENGINE)

TABLE 6. ENGINE TROUBLESHOOTING (CONTINUED)

SYMPTOM	POSSIBLE PROBLEM	SOLUTION
Insufficient power output "compression" and overheats	Malfunction in blower?	Check or replace blower.
	Air in-take filter clogged?	Clean or replace air in-take filter.
Burns to much fuel	Over accumulation of exhaust products?	Clean and check valves. Check muffler, replace if necessary.
	Wrong spark plug?	Replace spark plug with manufactures suggested type spark plug.
Exhaust color is continously "WHITE"	Lubricating oil is wrong viscosity?	Replace lubricating oil with correct viscosity.
	Worn rings?	Replace rings
Exhaust color is continously "BLACK"	Air cleaner clogged?	Clean or replace air cleaner.
	Choke valve has not been set to the correct position?	Adjust choke valve to the correct position.
	Carburetor defective, seal on carburetor broken?	Replace carburetor or seal.
	Poor carburetor adjustment "engine runs too rich?"	Adjust carburetor.

STOW G-4.5R — TROUBLESHOOTING (GENERATOR)

Practically all generator breakdowns can be prevented by proper handling and maintenance inspections, but in the event of a breakdown, please take a remedial action following the

diagnosis based on the Generator Troubleshooting (Table 7) information shown below and on the preceding page. If the problem cannot be remedied, please leave the unit just as it is and consult our company's business office or service plant.

TABLE 7. GENERATOR TROUBLESHOOTING

SYMPTOM	POSSIBLE PROBLEM	SOLUTION
Low voltage	Engine speed too low?	Raise engine speed to rated RPM.
Low voltage. Engine speed normal 3650 RPM (unloaded), 2500 RPM (idle)	AC voltmeter not working?	Replace AC voltmeter.
	Control box internal wiring malfunction?	Check control box wiring.
	Defective ignition coil?	Check red and green ignition wires. Replace ignition wires if necessary.
	Rotor winding malfunction?	Check or replace rotor.
	Stator winding malfunction?	Check or replace stator.
	Breaker malfunction?	Check or replace CB1.
Voltage output too high.	Engine speed too high?	Lower engine speed to rated RPM.
Voltage output too high. Engine speed normal 3650 RPM (unloaded), 2500 RPM (idle)	Control box internal wiring malfunction	Check control box wiring.
Circuit breaker will not turn on "NO LOAD"	Defective circuit breaker?	Replace circuit breaker.
Circuit breaker will turn on "LOADED" but trips immediately.	Overload?	Reduce load or replace breaker.
	Load circuit is shorted?	Check load circuit for short.
Does not accelerate from low to high "NO LOAD"	Stuck solenoid?	Check solenoid.
Does not accelerate from low to high "LOAD ACTIVE"	Control box internal wiring defective?	Check control box wiring.
Does not decelerate no "VOLTAGE OUTPUT".	Defective rotor windings?	Check or replace rotor.
	Defective solenoid?	Check or replace solenoid.
	Defective idle control device?	Check or replace idle control device.
	Defective solenoid?	Check or replace idle control device.
Does not decelerate but has "VOLTAGE OUTPUT".	Control box wiring malfunction?	Check control box wiring, replace any defective components.
	Defective solenoid?	Check or replace solenoid.
	Idle control device malfunction?	Check or replace idle control device.

STOW G-4.5R — EXPLANATION OF CODE IN REMARKS COLUMN

How to read the marks and remarks used in this parts book.

Items Found In the “Remarks” Column

Serial Numbers-Where indicated, this indicates a serial number range (inclusive) where a particular part is used.

Model Number-Where indicated, this shows that the corresponding part is utilized only with this specific model number or model number variant.

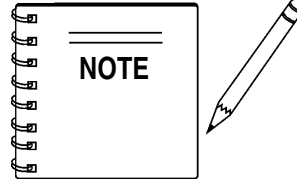

The contents of this catalog are subject to change without notice.

Items Found In the “Items Number” Column

All parts with same symbol in the number column, *, #, +, %, or <, belong to the same assembly or kit.

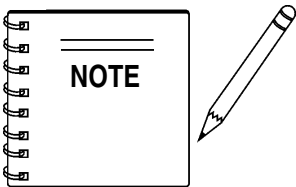

If more than one of the same reference number is listed, the last one listed indicates newest (or latest) part available.

STOW G-4.5R — SUGGESTED SPARE PARTS

G-4.5R 1 TO 3 UNITS WITH ROBIN EX270D20110 ENGINE

1 to 3 Units

Qty.	P/N	Description
1	0810106004	CAP, FUEL TANK, S/N 5498030 AND BELOW
1	A9924800014	CAP, FUEL TANK, S/N 5498031 AND ABOVE
1	0810107103	FUEL FILTER, TANK, S/N 5498030 AND BELOW
1	A9924800004	FUEL FILTER, FUEL TANK, S/N 5498031 AND ABOVE
3	0650140150	SPARK PLUG
3	2793260907	ELEMENT, AIR CLEANER
1	2795011008	ROPE, RECOIL STARTER

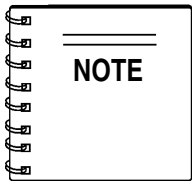

Part numbers on this
Suggested Spare Parts
List may supercede/
replace the P/N shown in
the text pages of this
book.

STOW G-4.5R — NAME PLATE AND DECALS (S/N 5498030 AND BELOW)

NAMEPLATE AND DECALS (S/N 5498030 AND BELOW)

<u>NO.</u>	<u>PART NO.</u>	<u>PART NAME</u>	<u>QTY.</u>	<u>REMARKS</u>
1	A3512100502	DECAL; CONTROL PANEL	1	A21220080
2	1630680104	DECAL; FUEL COCK	1	S-1407
3		NAMEPLATE	1	CONTACT STOW PARTS DEPT.
4	0800628504	DECAL; GROUND	1	S-1123
5	8700611804	DECAL; WARNING DANGEROUS GAS	1	S-4984
6	8700611904	DECAL; DANGER ELECTRICAL SHOCK HAZ.	1	S-4985
7	7900638204	DECAL; OPERATING INSTRUCTIONS	1	S-4607
8	7900636004	DECAL; CAUTION OPER. AT 3600 RPM ONLY	1	S-4461
9	0820610404	DECAL; WARNING	1	S-3627
10	0820610304	DECAL; CAUTION	1	3311
11	A3562000003	DECAL; STOW	1	A36200000

STOW G-4.5R — NAME PLATE AND DECALS (S/N 5498030 AND ABOVE)

NAMEPLATE AND DECALS (S/N 5498031 AND ABOVE)

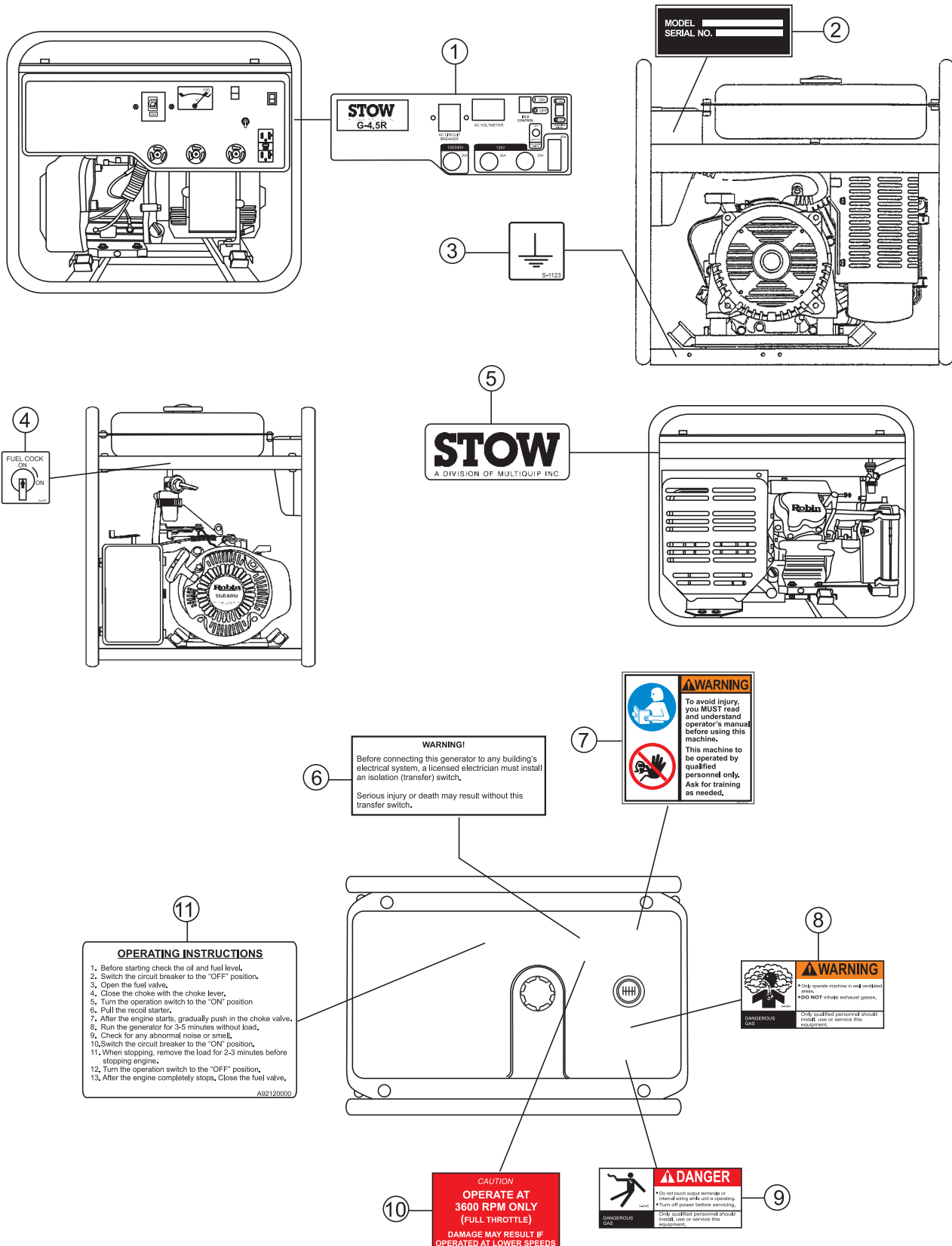

STOW G-4.5R — NAME PLATE AND DECALS (S/N 5498030 AND ABOVE)

NAMEPLATE AND DECALS (S/N 5498031 AND ABOVE)

<u>NO.</u>	<u>PART NO.</u>	<u>PART NAME</u>	<u>QTY.</u>	<u>REMARKS</u>
1	A4511200402	DECAL; CONTROL PANEL	1	A41120040
2		NAMEPLATE	1	CONTACT STOW PARTS DEPT.
3	0800628504	DECAL; GROUND	1	S-1123
4	1630680104	DECAL; FUEL COCK	1	S-1407
5	A4561000203	DECAL; STOW	1	
6	0820610404	DECAL; WARNING	1	S-3627
7	35137	DECAL; WARNING READ MANUAL	1	
8	8700611804	DECAL; WARNING DANGEROUS GAS	1	S-4984
9	8700611904	DECAL; DANGER ELECTRICAL SHOCK HAZ.	1	S-4985
10	7900636004	DECAL; CAUTION OPER. AT 3600 RPM ONLY	1	S-4461
11	A92120000	DECAL; OPERATING INSTRUCTIONS	1	

STOW G-4.5R — GENERATOR ASSY.

GENERATOR ASSY.

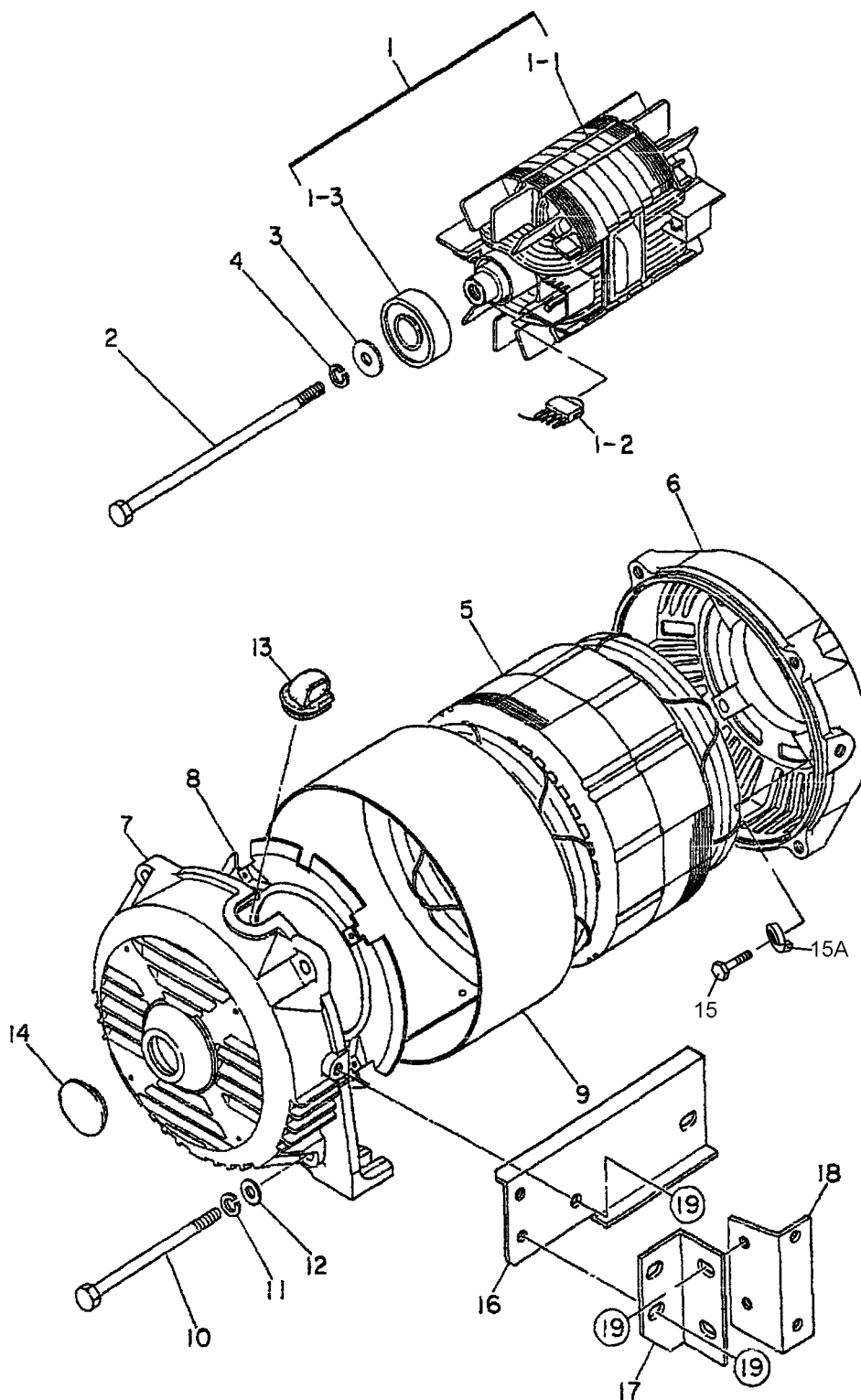

STOW G-4.5R — GENERATOR ASSY.

GENERATOR ASSY.

<u>NO</u>	<u>PART NO</u>	<u>PART NAME</u>	<u>QTY.</u>	<u>REMARKS</u>
1	A3110200003	ROTOR ASSY.	1	INCLUDES ITEMS W/*
1-1*	7661080003	FIELD COIL ASSY.	1	
1-2	0601823213	RECTIFIER	2	D3SB 80
1-2	0601822638	SURGE ABSORBER	2	TNR 15G431K
1-3*	0071706304	BEARING	1	6304 2RU NYCM
2	7661017104	SET BOLT, ROTOR	1	
3	0801086104	SET WASHER, BEARING	1	
4	0040010000	SPRING WASHER	1	
5	A3136001203	ARMATURE ASSY.	1	
6	A3155100002	END BRACKET (C SIDE)	1	
7	A3155000002	END BRACKET (B SIDE)	1	
8	7875021523	GUIDE PANEL, AIR	1	
9	7661331003	COVER	1	
10	7661344204	SET BOLT, STATOR	4	
11	0040008000	SPRING WASHER	4	
12	0041208000	PLAIN WASHER	4	
13	7871329514	GROMMET	1	
14	0601851760	CAP	1	
15	0013608025	HEX. HEAD BOLT	4	S/N 5498030 AND BELOW
15	0013608025	HEX. HEAD BOLT	4	S/N 5498031 AND ABOVE
15A	0040008025	SPRING WASHER	4	S/N 5498030 AND BELOW
15A	0040008000	SPRING WASHER	4	S/N 5498031 AND ABOVE
16	A3332400304	MUFFLER BRACKET	1	S/N 5498030 AND BELOW
17	A3332400204	MUFFLER BRACKET	1	S/N 5498030 AND BELOW
18	A3332400104	MUFFLER BRACKET	1	S/N 5498030 AND BELOW
19	0017108020	HEX. HEAD BOLT	6	S/N 5498030 AND BELOW

STOW G-4.5R — CONTROL BOX ASSY. (S/N 549830 AND BELOW)

CONTROL BOX ASSY. (S/N 549830 AND BELOW)

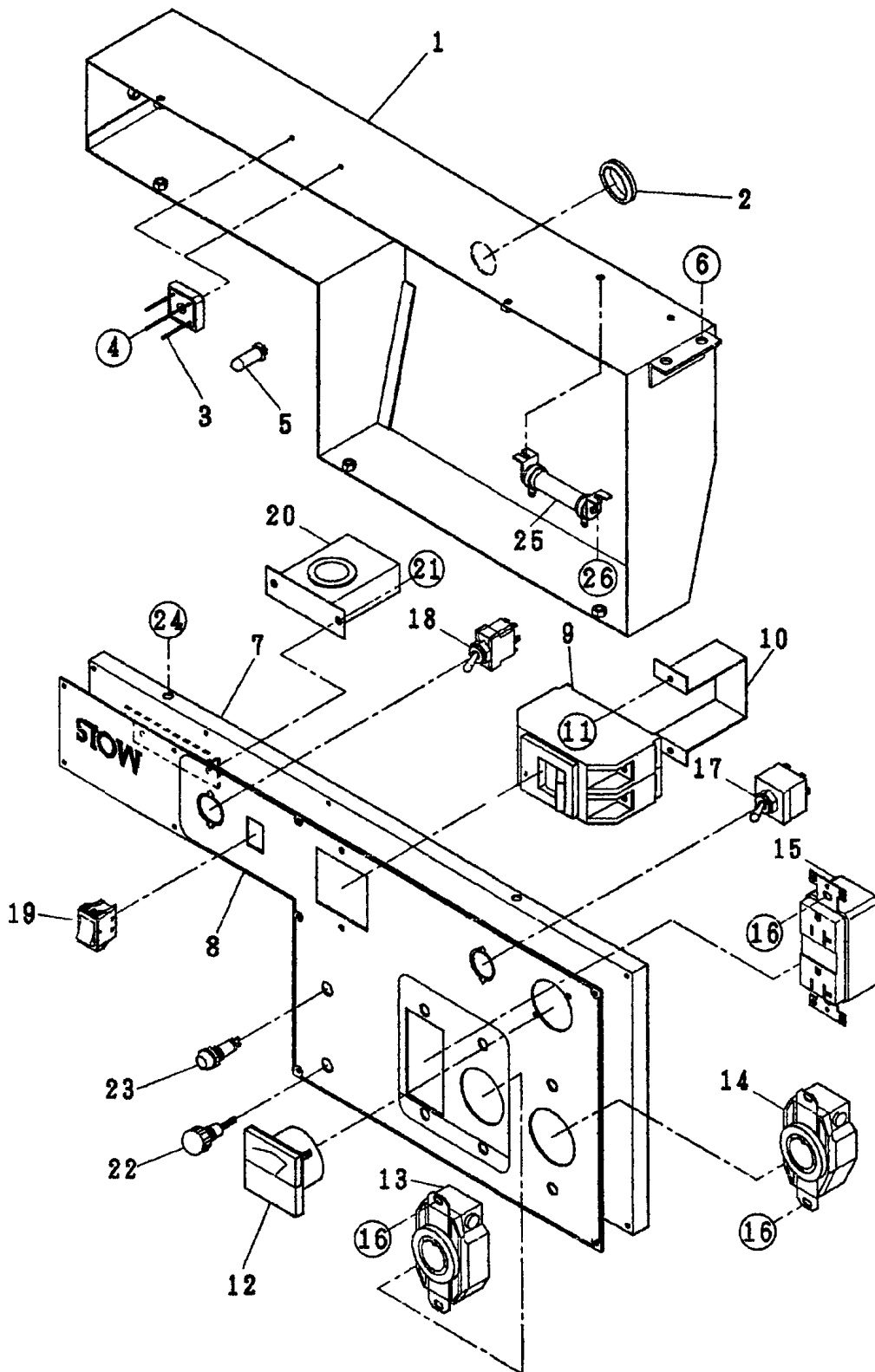

STOW G-4.5R — CONTROL BOX ASSY. (S/N 549830 AND BELOW)

CONTROL BOX ASSY. (S/N 549830 AND BELOW)

<u>NO</u>	<u>PART NO</u>	<u>PART NAME</u>	<u>QTY.</u>	<u>REMARKS</u>
1	A3215000303	CONTROL BOX	1	
2	0601850215	GROMMET	1	
3	0601823204	RECTIFIER	2	S5VB60
4	0027103012	MACHINE SCREW	2	
5	A3262800004	CONDENSER	1	
6	0017106016	HEX. HEAD BOLT	4	
7	A3225000603	CONTROL PANEL	1	
8	A3512100502	NAME PLATE	1	A31210050
9	0601802651	CIRCUIT BREAKER	1	KM-2 :15A
10	4341817004	BRACKET, CIRCUIT BREAKER	1	
11	0021004010	MACHINE SCREW	2	
12	0601806819	AC VOLTMETER	1	DE450-011 : 0 ~ 120/240V
13	0601811035	RECEPTACLE	1	L5-30R : 125V, 30A
14	0601811032	RECEPTACLE	1	L6-20R : 250V, 20A
15	0601812598	RECEPTACLE	1	5-20R : 125V, 20A
16	0021004010	MACHINE SCREW	6	
17	0601830737	SWITCH, FULL POWER	1	ET330D12
18	0601830727	SWITCH, IDLE CONTROL	1	ET115A12
19	0601831600	SWITCH, OPERATION	1	JW-M11RKK
20	0601823853	SLOW DOWN UNIT	1	ND80B
21	0027104010	MACHINE SCREW	2	
22	0601815109	GROUND TERMINAL	1	
23	0601810553	ALARM LAMP, OIL	1	D121091SR :12V
24	0017105010	HEX. HEAD BOLT	5	
25	0601842426	RESISTOR	1	40W, 400
26	0027104012	MACHINE SCREW	2	
26	0207004000	HEX.NUT	2	

STOW G-4.5R — CONTROL BOX ASSY. (S/N 549831 AND ABOVE)

CONTROL BOX ASSY. (S/N 549831 AND ABOVE)

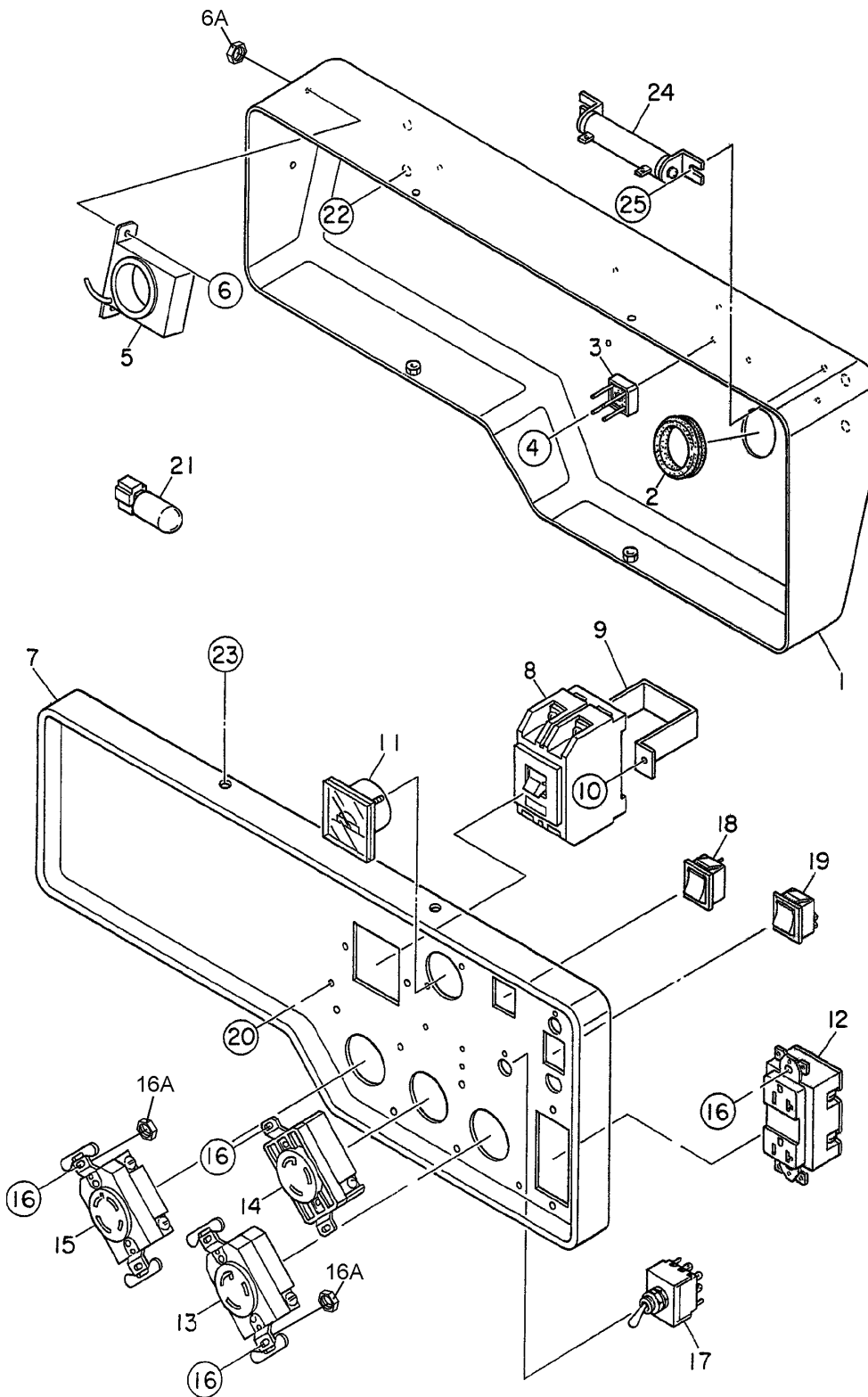

STOW G-4.5R — CONTROL BOX ASSY. (S/N 549831 AND ABOVE)

CONTROL BOX ASSY. (S/N 549831 AND ABOVE)

<u>NO</u>	<u>PART NO</u>	<u>PART NAME</u>	<u>QTY.</u>	<u>REMARKS</u>
1	A3214000003	CONTROL BOX	1	
2	0601850102	GROMMET	1	
3	0601823204	RECTIFIER	2	S5VB60
4	0027103012	MACHINE SCREW	2	
5	0601823853	SLOW-DOWN UNIT	1	ND-80
6	0027104010	MACHINE SCREW	2	
6A	0207004000	HEX NUT	2	
7	A3224000003	CONTROL PANEL	1	
8	0601802651	CIRCUIT BREAKER.....	1	KM-2 :15A
9	4341817004	BRACKET, CIRCUIT BREAKER	1	
10	0021004010	MACHINE SCREW	2	
11	0601806819	AC VOLTMETER	1	DE450-011 : 0 ~ 120/240V
12	0601812598	RECEPTACLE	1	5-20R : 125V, 20A
13	0601812592	RECEPTACLE	1	L5-20R : 125V, 20A
14	0601811035	RECEPTACLE	1	L5-30R : 125V, 30A
15	0601814010	RECEPTACLE	1	L14-20R :125/250V, 30A
16	0021004010	MACHINE SCREW	8	
16A	0207004000	HEX NUT	8	
17	0601830737	SWITCH, FULL POWER	1	ET330D12
18	0601831620	SWITCH, IDLE CONTROL	1	C1550WA
19	0601831620	SWITCH, OPERATION	1	C1550WA
20	0021004015	MACHINE SCREW	1	
20A	0207004000	HEX NUT	1	
21	A3262800004	CONDENSER ASSY. 50V @ 1000 μ F	1	VR1H102MHA
22	0017106016	HEX. HEAD BOLT	4	
23	0017105010	HEX. HEAD BOLT	4	
24	0601842426	RESISTOR	1	40W, 400 OHMS
25	0027104010	MACHINE SCREW	2	

STOW G-4.5R — PIPE FRAME ASSY. (S/N 549830 AND BELOW)

PIPE FRAME ASSY. (S/N 549830 AND BELOW)

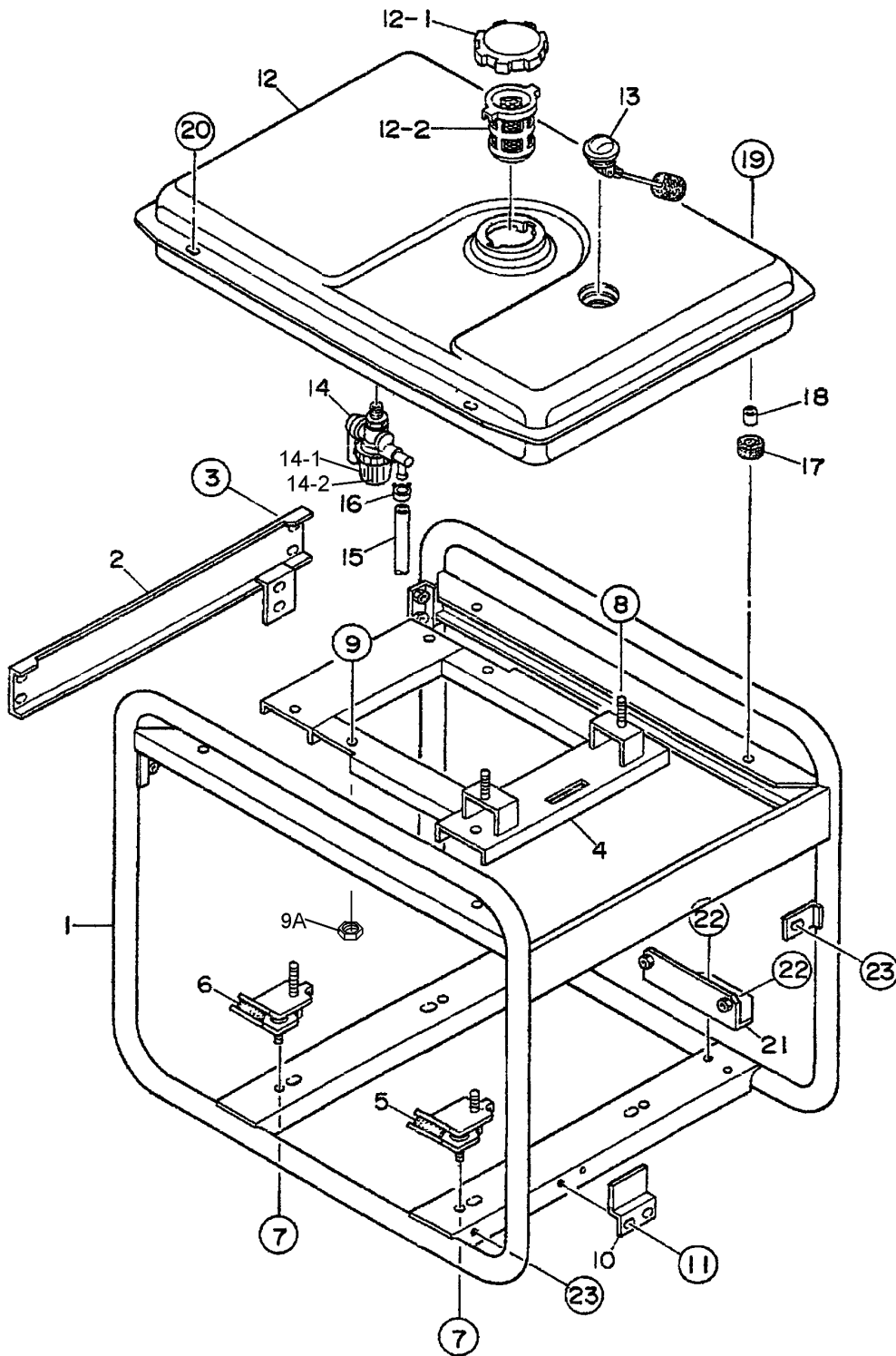

STOW G-4.5R — PIPE FRAME ASSY. (S/N 549830 AND BELOW)

PIPE FRAME ASSY. (S/N 549830 AND BELOW)

<u>NO</u>	<u>PART NO</u>	<u>PART NAME</u>	<u>QTY.</u>	<u>REMARKS</u>
1	A3418000112	PIPE FRAME	1	
2	A3485500004	SUPPORT, PIPE FRAME	1	
3	0017106016	HEX. HEAD BOLT	4	
4	A3305100103	ENGINE BASE	1	
5	A9312601704	RUBBER SUSPENSION	2	
6	7935416004	RUBBER SUSPENSION	2	
7	0207008000	HEX. NUT	8	
8	0207008000	HEX. NUT	2	
9	0017108040	HEX. HEAD BOLT	2	
9A	0207008000	HEX. NUT	2	
10	A3305200104	STOPPER	1	
11	0017106016	HEX. HEAD BOLT	2	
12	A3365000102	FUEL TANK	1	
12-1	0810106004	CAP, FUEL TANK	1	
12-2	0810107103	FUEL FILTER	1	
13	0602125034	FUEL GUAGE	1 CJ-58A
14	0605510026	FUEL STRAINER	1	
14-1	0642007810	CUP, FILTER FUEL STRAINER	1	
14-2	0642006410	PACKING, FUEL STRAINER CUP	1	
15	0605513169	HOSE	1	
16	0605515105	HOSE BAND	2	
17	7855525514	RUBBER CUSION	2	
18	7855525604	COLLAR	2	
19	0017108030	HEX. HEAD BOLT	2	
20	0017108020	HEX. HEAD BOLT	2	
21	A3332400004	BRACKET	1	
22	0017106016	HEX. HEAD BOLT	4	
23	0019206016	HEX. HEAD BOLT	2	

STOW G-4.5R — PIPE FRAME ASSY. (S/N 549831 AND ABOVE)

PIPE FRAME ASSY. (S/N 549830 AND ABOVE)

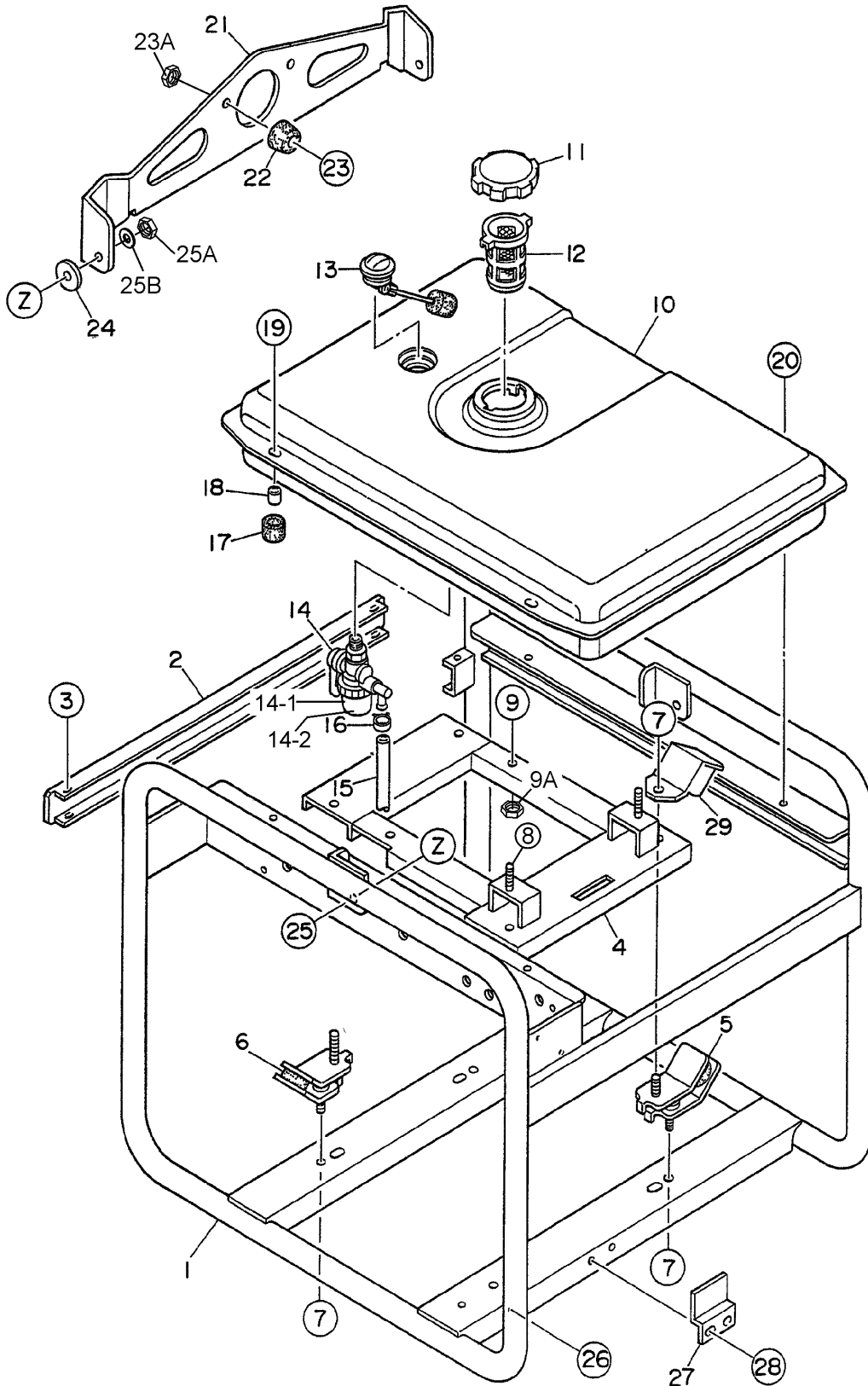

STOW G-4.5R — PIPE FRAME ASSY. (S/N 549831 AND ABOVE)

PIPE FRAME ASSY. (S/N 549830 AND ABOVE)

<u>NO</u>	<u>PART NO</u>	<u>PART NAME</u>	<u>QTY.</u>	<u>REMARKS</u>
1	A4417000002	PIPE FRAME	1	
2	A3417100004	BRACKET	1	
3	0017106016	HEX. HEAD BOLT	4	
4	A3304100003	ENGINE BASE	1	
5	A9312601704	RUBBER SUSPENSION	2	
6	7935416004	RUBBER SUSPENSION	2	
7	0207008000	HEX. NUT	8	
8	0207008000	HEX. NUT	2	
9	0017108040	HEX. HEAD BOLT	2	
9A	0207008000	HEX. NUT	2	
10	A4364000002	FUEL TANK	1	
11	A9924800014	CAP, FUEL TANK	1	
12	0810107103	FUEL FILTER	1	
13	0602125034	FUEL GUAGE	1 CJ-58A
14	0605510026	FUEL STRAINER	1	
14-1	0642007810	CUP, FILTER FUEL STRAINER	1	
14-2	0642006410	PACKING, FUEL STRAINER CUP	1	
15	0605513194	HOSE	1	
16	0605515062	HOSE BAND	2	
17	7855525514	RUBBER CUSION	2	
18	7855525604	COLLAR	2	
19	0017108030	HEX. HEAD BOLT	2	
20	0017108020	HEX. HEAD BOLT	2	
21	A9117200103	HANGER	1	
22	0601850097	STOPPER	1	
23	0021008025	MACHINE SCREW	1	
23A	0207008000	HEX NUT	1	
24	A9311100004	PLASTIC WASHER	2	
25	0011308025	HEX HEAD BOLT	2	
25A	0037908000	HEX NUT	2	
25B	0042108000	WASHER, FLAT	2	
26	0019206016	HEX HEAD BOLT	1	
27	A3305200104	STOPPER	1	
28	0017106016	HEX HEAD BOLT	2	
29	A3414500004	COVER		

ROBIN EX270D20110—CRANKCASE ASSY.

CRANKCASE ASSY..

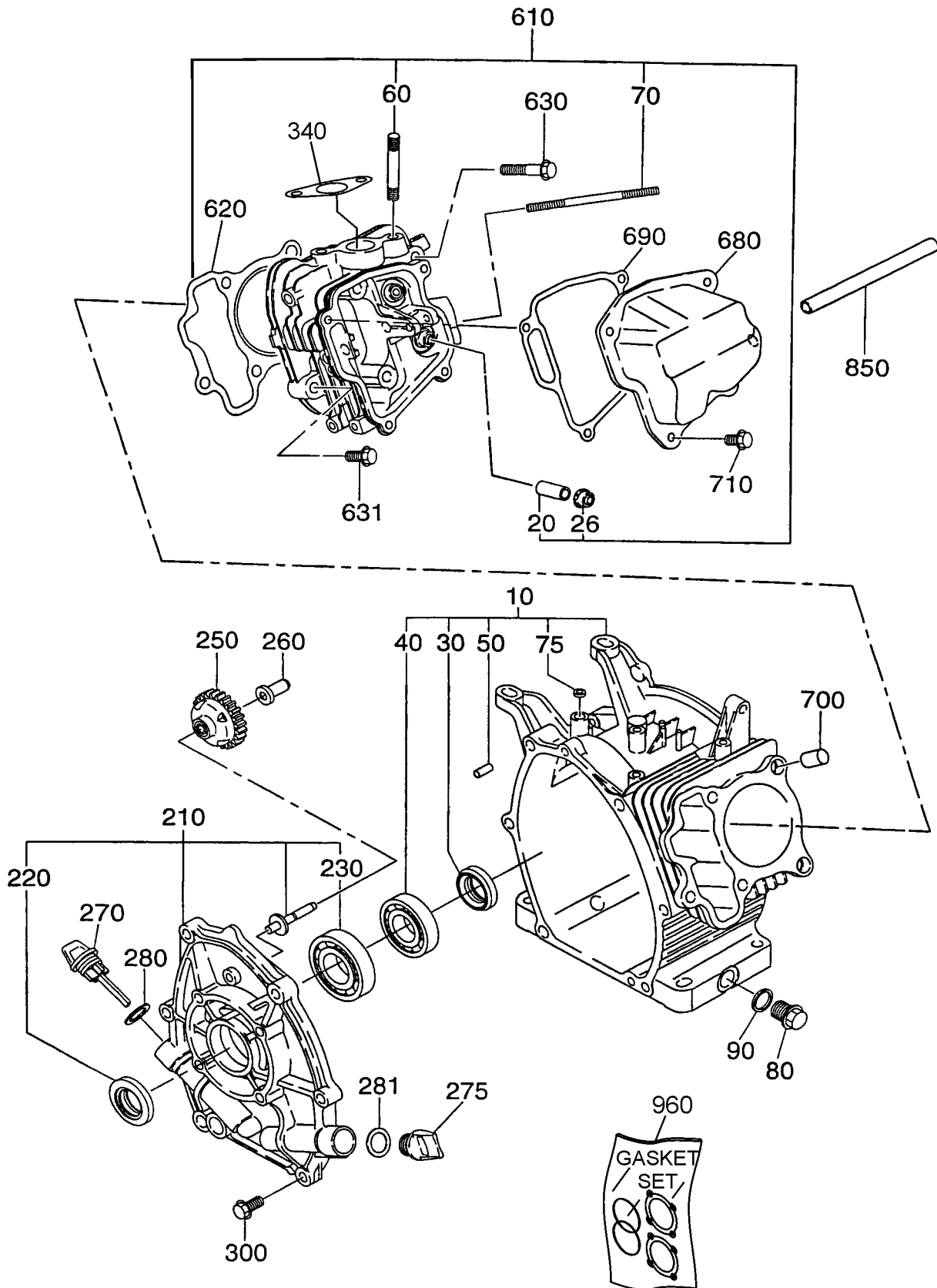

ROBIN EX270D20110— CRANKCASE ASSY.

CRANKCASE ASSY.

<u>NO</u>	<u>PART NO</u>	<u>PART NAME</u>	<u>QTY.</u>	<u>REMARKS</u>
10	2791010251	CRANKCASE ASSY.	1	INCLUDES ITEMS W/*
20%	2371420203	VALVE GUIDE	2	
26%	2771601001	STEM SEAL	1	
30*	0440300110	OIL SEAL	1	
46*	0600300341	BALL BEARING	1	
50*	2771501103	PIPE KNOCK	2	
60%	0105080250	STUD	2	
70%	0105060410	STUD	2	
75	0440060020	OIL SEAL	1	
80	0401140020	PLUG	2	
90	0211140020	GASKET	2	
210	2791100121	MAIN BEARING COVER	1	INCLUDES ITEMS W/+
220+	0440300160	OIL SEAL	1	
230+	0600300370	BALL BEARING	1	
250	2774500421	GOVERNOR GEAR	1	
260	2774190103	GOVERNOR SLEEVE	1	
275	2796500103	FILLER PLUG	1	
280\$	0213200050	GASKET	1	
281	0213200050	GASKET	1	
300	0010408350	FLANGE BOLT	7	
340\$	2773520103	GASKET, MUFFLER 26D 9DX58P 0.2T	1	
610	2791300111	CYLINDER HEAD ASSY	1	INCLUDES ITEMS W/%
620\$	2791500123	GASKET HEAD	1	
630	0110080240	FLANGE BOLT	4	
631	0010408350	FLANGE BOLT	1	
680	2771550101	ROCKER COVER	1	
690\$	2771600103	GASKET, ROCKET COVER	1	
700	2771501103	PIPE KNOCK	2	
710	0110060020	FLANGE BOLT	4	
850	0851080000	RUBBER PIPE	1	
960	2799900107	GASKET SET	1	INCLUDES ITEMS W/\$

ROBIN EX270D20110 — CRANKSHAFT AND PISTON ASSY.

CRANKSHAFT AND PISTON ASSY.

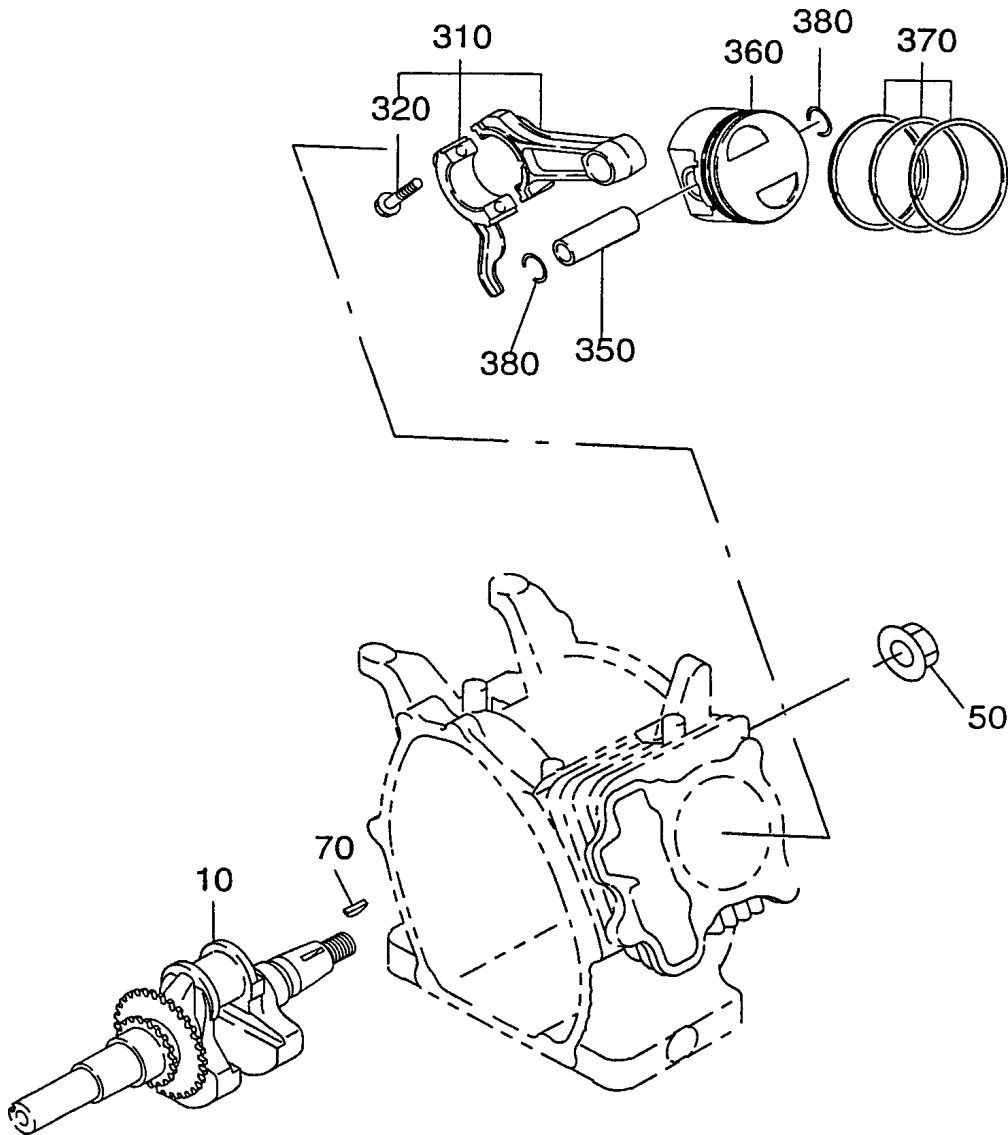

ROBIN EX270D20110 — CRANKSHAFT AND PISTON ASSY.

CRANKSHAFT AND PISTON ASSY.

<u>NO</u>	<u>PART NO</u>	<u>PART NAME</u>	<u>QTY.</u>	<u>REMARKS</u>
10	2792120131	CRANKSHAFT CP	1	
50	0180180010	FLANGE NUT	1	
70	0323030010	WOODRUFF KEY	1	
310	2792250120	CONNECTING ROD ASSY.	1	INCLUDES ITEM W/*
320*	2792300103	CONNECTING ROD BOLT	2	
350	2792330103	PISTON PIN	1	
360	2792340103	PISTON, STANDARD	1	
360	2792340303	PISTON OVERSIZE 0.25 MM	1	
360	2792340403	PISTON OVERSIZE 0.50 MM	1	
370	2792351107	PISTON RING SET, STANDARD	1	
370	2792351207	PISTON RING SET, 0.25 MM	1	
370	2792351307	PISTON RING SET, STANDARD	1	
380	0565180010	CLIP	2	

ROBIN EX270D20110 — GOVERNOR ASSY.

GOVERNOR ASSY.

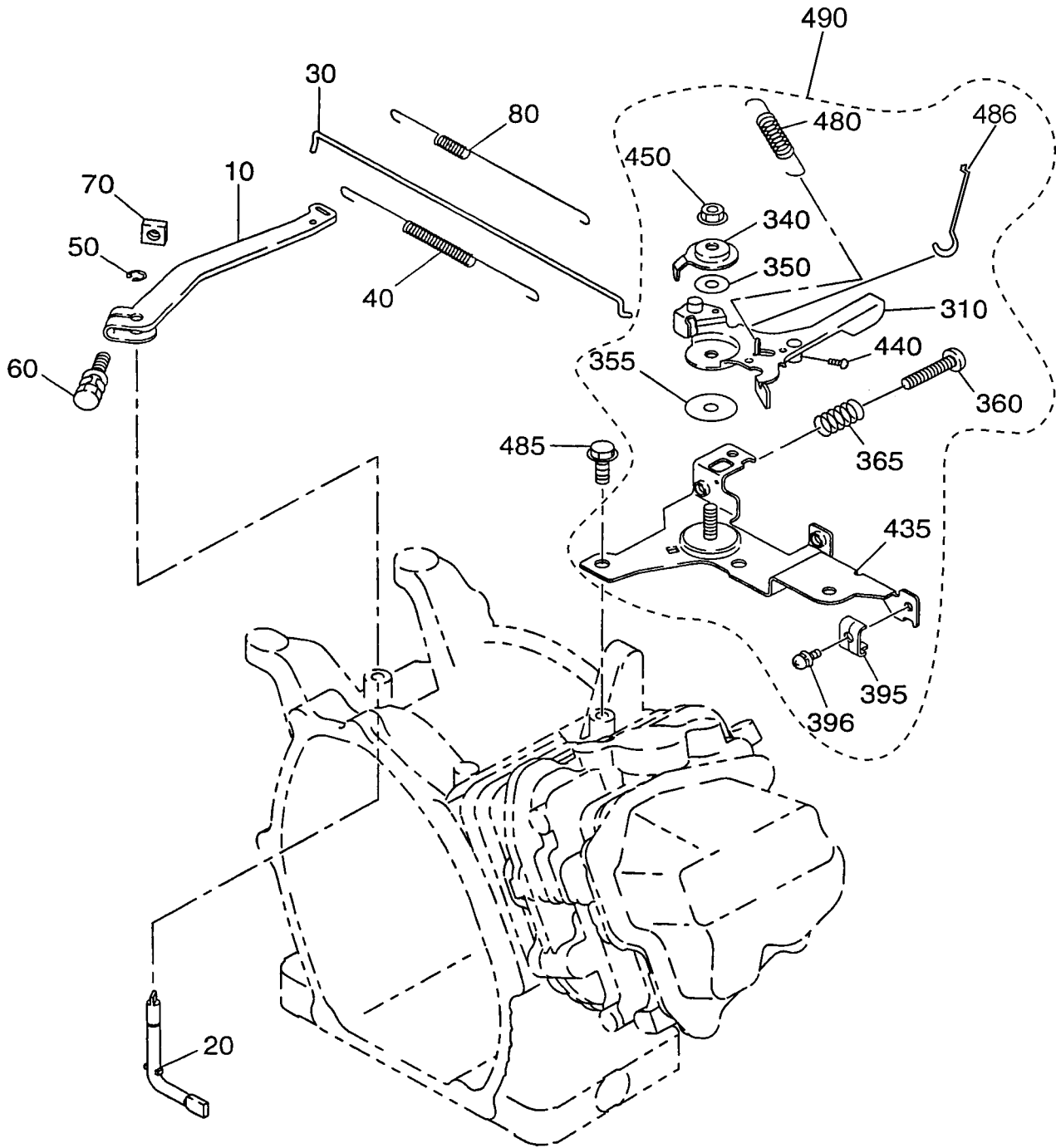

ROBIN EX270D20110 — GOVERNOR ASSY.

GOVERNOR OPERATION ASSY.

<u>NO</u>	<u>PART NO</u>	<u>PART NAME</u>	<u>QTY.</u>	<u>REMARKS</u>
10	2794230113	GOVERNOR LEVER	1	
20	2774220133	GOVERNOR SHAFT	1	
30	2794270101	GOVERNOR ROD CP	1	
40	2774280113	ROD SPRING	1	
50	0031305000	CLIP	1	
60	0130060240	BOLT & WASHER ASSY.	1	
70	0186060020	NUT	1	
80	2794250223	GOVERNOR SPRING	1	
310*	2774330301	SPEED CONTROL LEVER	1	
340*	2774350103	STOP PLATE	1	
350*	0200060170	WASHER	1	
355*	0217060070	FRICTION WASHER	1	
360*	0140060180	SCREW	1	
365*	2374500423	SPRING, ADJUST	1	
370	0021706000	NUT	1	
435*	2774600101	SPEED CONT. BRKT CP	1 CAN ONLY BE PURCHASED W/ITEM 490
395*	2774390203	CLAMP	1	
396*	0131050030	SCREW AND WASHER ASSY.	1	
440*	0043104080	SCREW	1	
450*	0023506000	SELF LOCK NUT	1	
480*	2774510103	RETURN SPRING	1	
485	0110060020	FLANGE BOLT	2	
486	2774370103	LINK ROD	1	
490	2774600303	SPEED CONTROL ASSY.	1 INCLUDES ITEMS W/*

ROBIN EX270D20110 — INTAKE AND EXHAUST ASSY.

INTAKE AND EXHAUST ASSY.

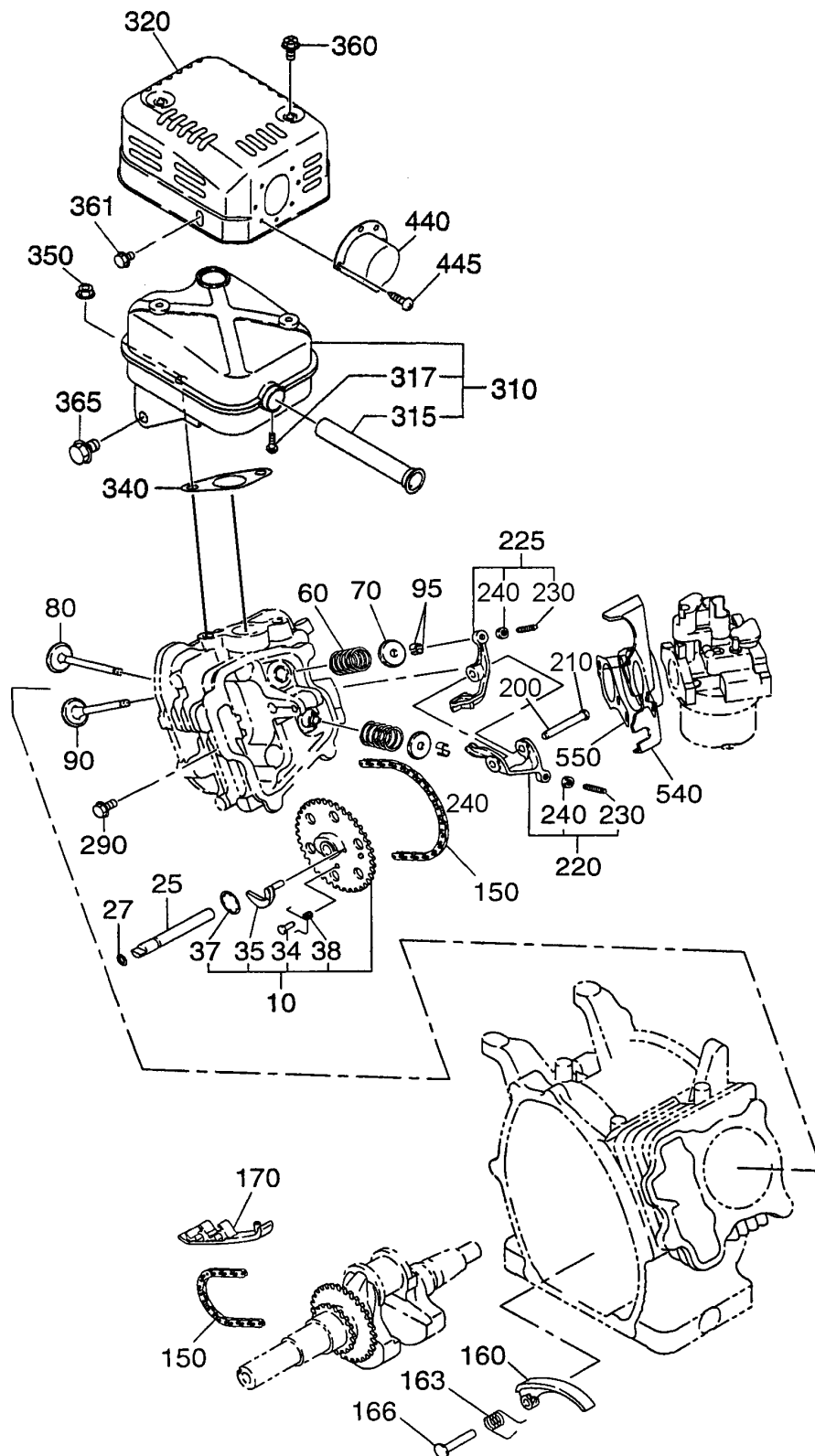

ROBIN EX270D20110 — INTAKE AND EXHAUST ASSY.

INTAKE AND EXHAUST ASSY.

<u>NO.</u>	<u>PART NO.</u>	<u>PART NAME</u>	<u>QTY.</u>	<u>REMARKS</u>
10	2793160101	CAMSHAFT CP	1	INCLUDES ITEMS W/*
25	2773510103	PIN, CAMSHAFT, 9DX78.5L	1	
27	0240060010	O RING, 5.8DX9.6DX1.9T	1	
34*	2773860103	SPRING PIN, 4DX7.5DX11L	1	
35*	2793640103	RELEASE LEVER	1	
37*	2773650103	CLIP, 13.8DX20.3DX0.4T	1	
38*	2773870103	RETURN SPRING	1	
60	2793360103	VALVE SPRING, 17DX2.3DX27L N=5.8	2	
70	2693370103	SPRING RETAINER	2	
80	2793340113	INTAKE VALVE, 28.5DX5.5DX67.8L	1	
90	2793350113	EXHAUST VALVE, 26.5DX5.5DX67.8L	1	
95	13210KA031	COLLET VALVE	4	
150	2793560111	TIMING CHAIN CP, 100 LINK	1	
160	2773691103	TENTIONER	1	
163	2773710103	SPRING, TENTIONER	1	
166	2773690203	PIN, TENTIONER, 6DX13DX34L	1	
170	2773691313	CHAIN GUIDE	1	
200	2773500123	PIN, ROCKER, 6DX9DX41L	1	
210	0031305000	CLIP	1	
220	2773620100	ROCKER ARM ASSY. IN	1	INCLUDES ITEMS W/#
225	2773620200	ROCKER ARM ASSY. EX	1	INCLUDES ITEMS W/#
230#	0149050020	ADJUST SCREW, M5X0.5X23L	1	
240#	0170050030	NUT, M5X0.5X4.1H	1	
290	0110060020	FLANGE BOLT, M6X1.0X12L	1	
310	2793020111	MUFFLER, CP	1	
315	2793760101	SPARK ARRESTOR	1	
317	0150040060	TAPPING SCREW	1	
320	2793420111	MUFFLER COVER CP	1	
340	2773520103	GASKET, MUFFLER 26D 9DX58P 0.2T	1	
350	9802008280	FLANGE NUT	2	
360	0152060090	TAPPING BOLT, M6X1.0X10L	2	
361	0110060010	FLANGE BOLT, M6X1.0X8L	1	
365	0110080150	FLANGE BOLT, M8X1.25X12L	1	
440	2773700103	DEFLECTOR	1	
445	0150040060	TAPPING SCREW	2	
540	2793290113	INSULATOR	1	
550	2793590123	GASKET, INSULATOR	1	

ROBIN EX270D20110 — AIR CLEANER ASSY.

AIR CLEANER ASSY.

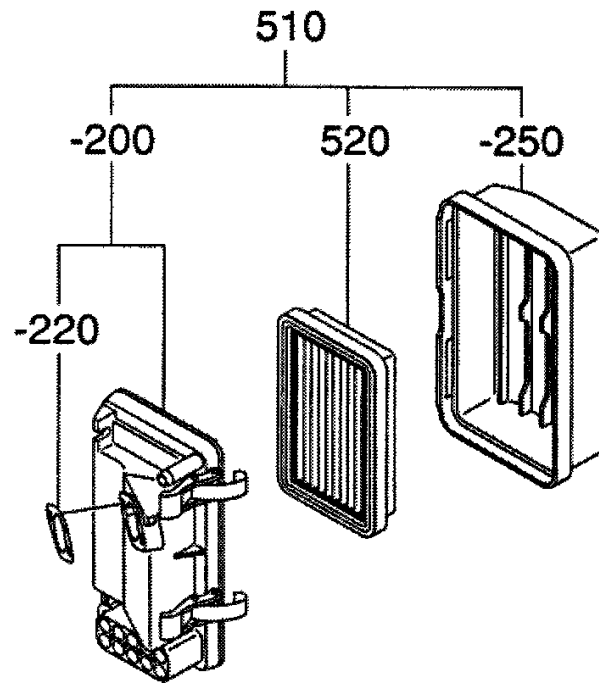

ROBIN EX270D20110 — AIR CLEANER ASSY.

AIR CLEANER ASSY.

<u>NO.</u>	<u>PART NO.</u>	<u>PART NAME</u>	<u>QTY.</u>	<u>REMARKS</u>
510	2793262030	AIR CLEANER ASSY. LOW PROFILE	1	INCLUDES ITEMS W/*
510-200*	2793263308	BODY CP	1	
510-220*	2793265008	GASKET	1	
510-250*	2793264508	COVER, LOW PROFILE	1	
520*	2793260907	ELEMENT ASSY.	1	

ROBIN EX270D20110 — COOLING STARTING ASSY.

COOLING STARTING ASSY.

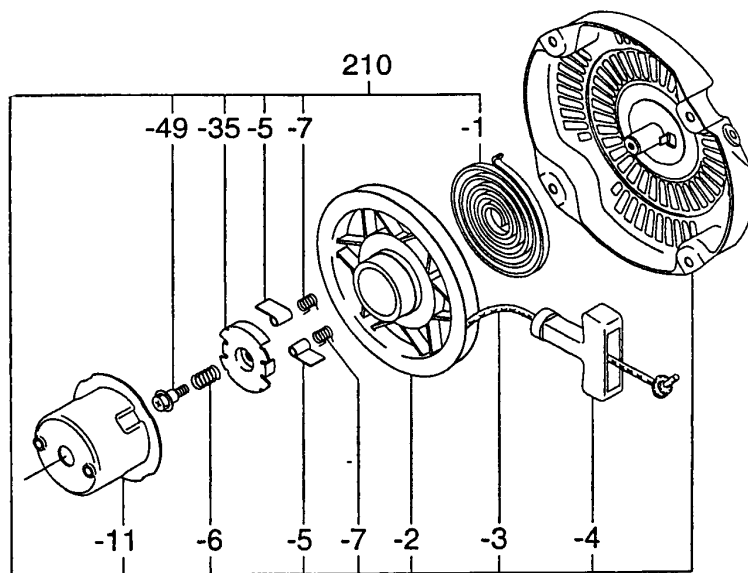
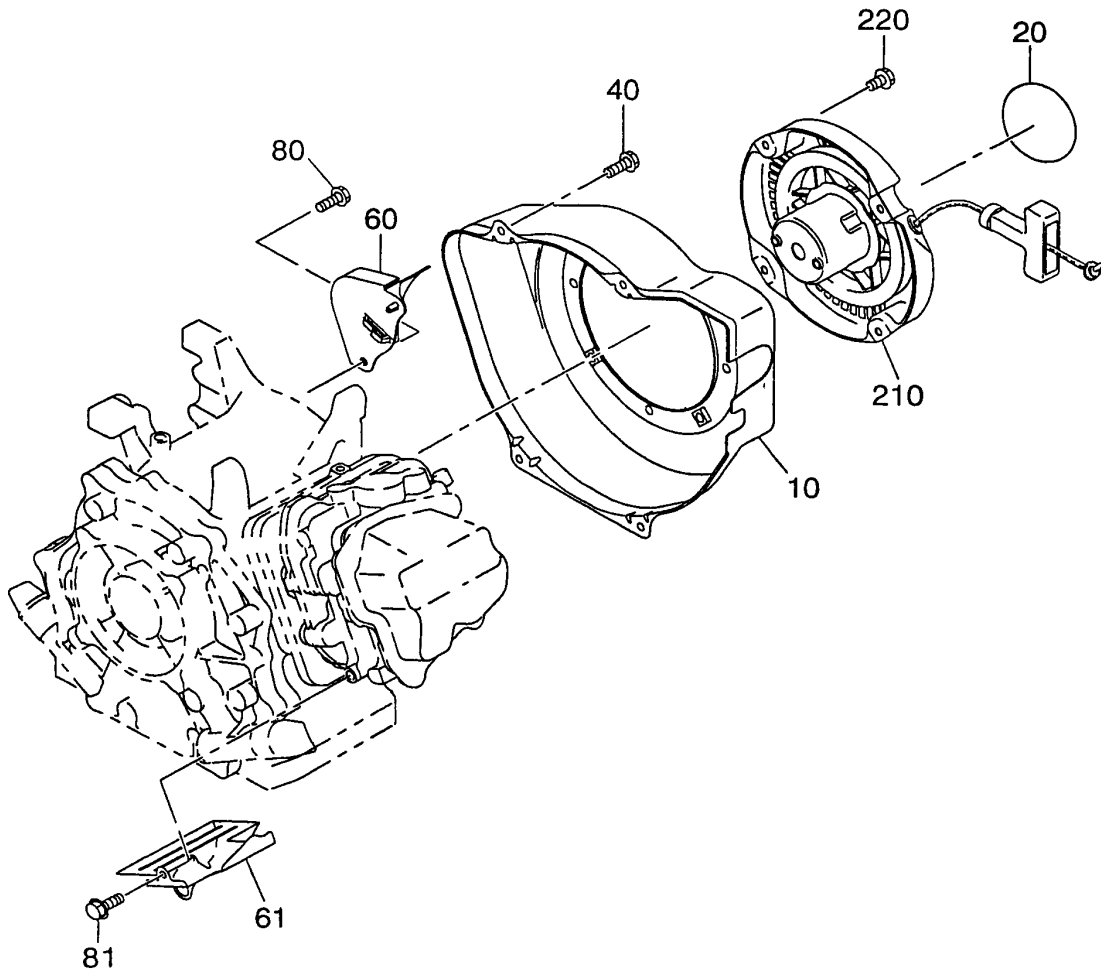

ROBIN EX270D20110 — COOLING STARTING ASSY.

COOLING STARTING ASSY.

<u>NO</u>	<u>PART NO</u>	<u>PART NAME</u>	<u>QTY.</u>	<u>REMARKS</u>
10	2795120111	BLOWER HOUSING CP, YELLOW	1	
20	0732005140	LABEL, TRADEMARK 64D	1	
40	0110060030	FLANGE BOLT	4	
60	2795271111	BAFFLE 1, CASE CP	1	
61	2795270213	BAFFLE 2, HEAD	1	
80	0016508120	BOLT	1	
81	0110060020	FLANGE BOLT	1	
210	2795020200	RECOIL STARTER ASSY.	1	INCLUDES ITEM W/*
210-1*	2265071608	SPIRAL SPRING	1	
210-2*	2795012008	REEL	1	
210-3*	2795011008	STARTER ROPE	1	
210-4*	2265070108	STARTER KNOB	1	
210-5*	2795012508	RATCHET	2	
210-6*	2265073108	FRICTION SPRING	1	
210-7*	2265075208	RATCHET SPRING	2	
210-11*	2795014508	STARTER PULLEY	1	
210-35*	2265074108	FRICTION PLATE	1	
210-49*	2265075308	CENTER SCREW	1	
220	0110060010	FLANGE BOLT	4	

ROBIN EX270D20110 — CARBURETOR ASSY.

FUEL LUBRICANT ASSY.

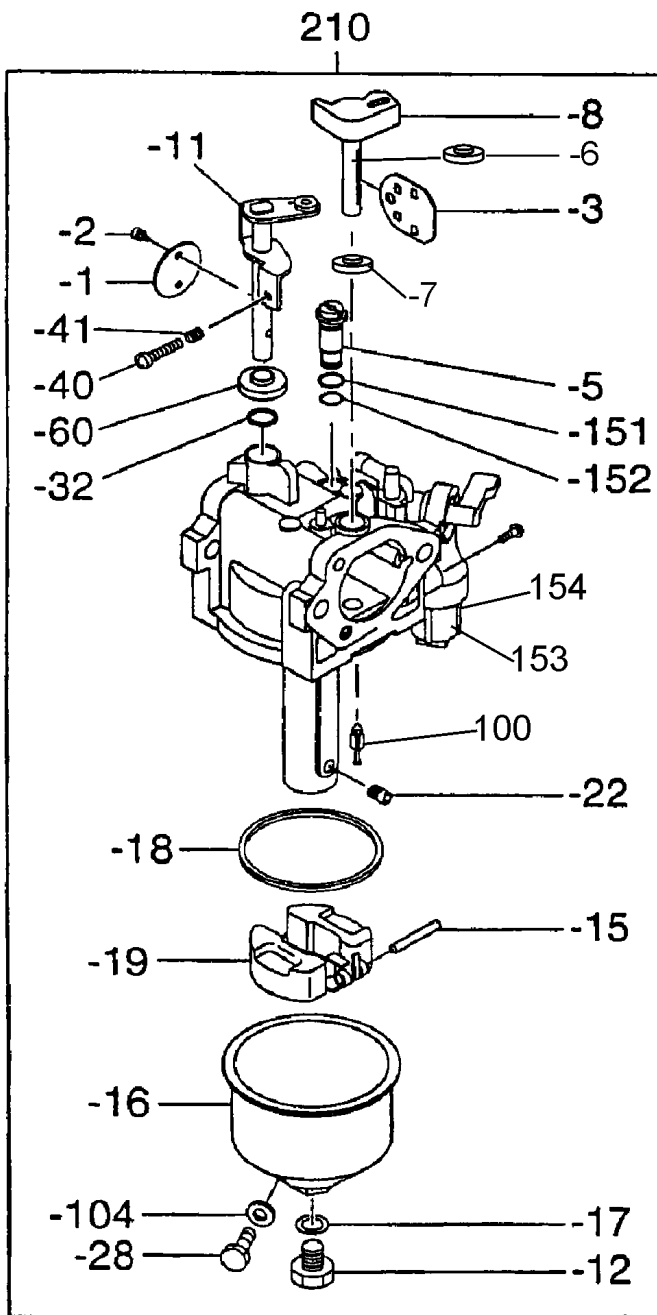

ROBIN EX270D20110 — CARBURETOR ASSY.

FUEL LUBRICANT ASSY.

<u>NO</u>	<u>PART NO</u>	<u>PART NAME</u>	<u>QTY.</u>	<u>REMARKS</u>
210	2796230100	CARBURETOR ASSY.	1	INCLUDES ITEM W/*
210-1*	2796253508	VALVE THROTTLE	1	
210-2*	2516245008	SCREW	2	
210-3*	2796252508	VALVE CHOKE	1	
210-5*	2796242008	JET SLOW	1	
210-6*	2796256308	COLLAR, UPPER, LOW PROFILE	1	
210-7*	2796256408	COLLAR, LOWER, LOW PROFILE	1	
210-8*	2796252008	SHAFT CHOKE	1	
210-11*	2796253008	SHAFT SUB ASSY., THROTTLE	1	
210-12*	2516245308	SCREW	1	
210-15*	2796251508	PIN FLOAT LEVER	1	
210-16*	2796255008	CHAMBER FLOAT	1	
210-17*	2796235008	GASKET	1	
210-18*	2796254008	GASKET CHAMBER	1	
210-19*	2796250508	FLOAT SUB ASSY.	1	
210-22*	2796240008	JET MAIN	1	
210-22*	2796240108	JET MAIN	1	
210-28*	2796235508	SCREW DRAIN	1	
210-32*	2796256108	BUSH	1	
210-40*	2796235308	SCREW ADJUSTING	1	
210-41*	2796244508	SPRING	1	
210-60*	2796256208	COLLAR	1	
210-100	2796250008	VALVE, ASSY.	1	
210-104*	2796255208	GASKET	1	
210-121*	2516248008	CAP	1	
210-151*	2796245208	O-RING	1	
210-152*	2796245108	O-RING	1	
210-153*	0652007810	FILTER CUP	1	
210-154*	0642006410	PACKING, FILTER CUP	1	

ROBIN EX270D20110 — FLYWHEEL ASSY.

FLYWHEEL ASSY.

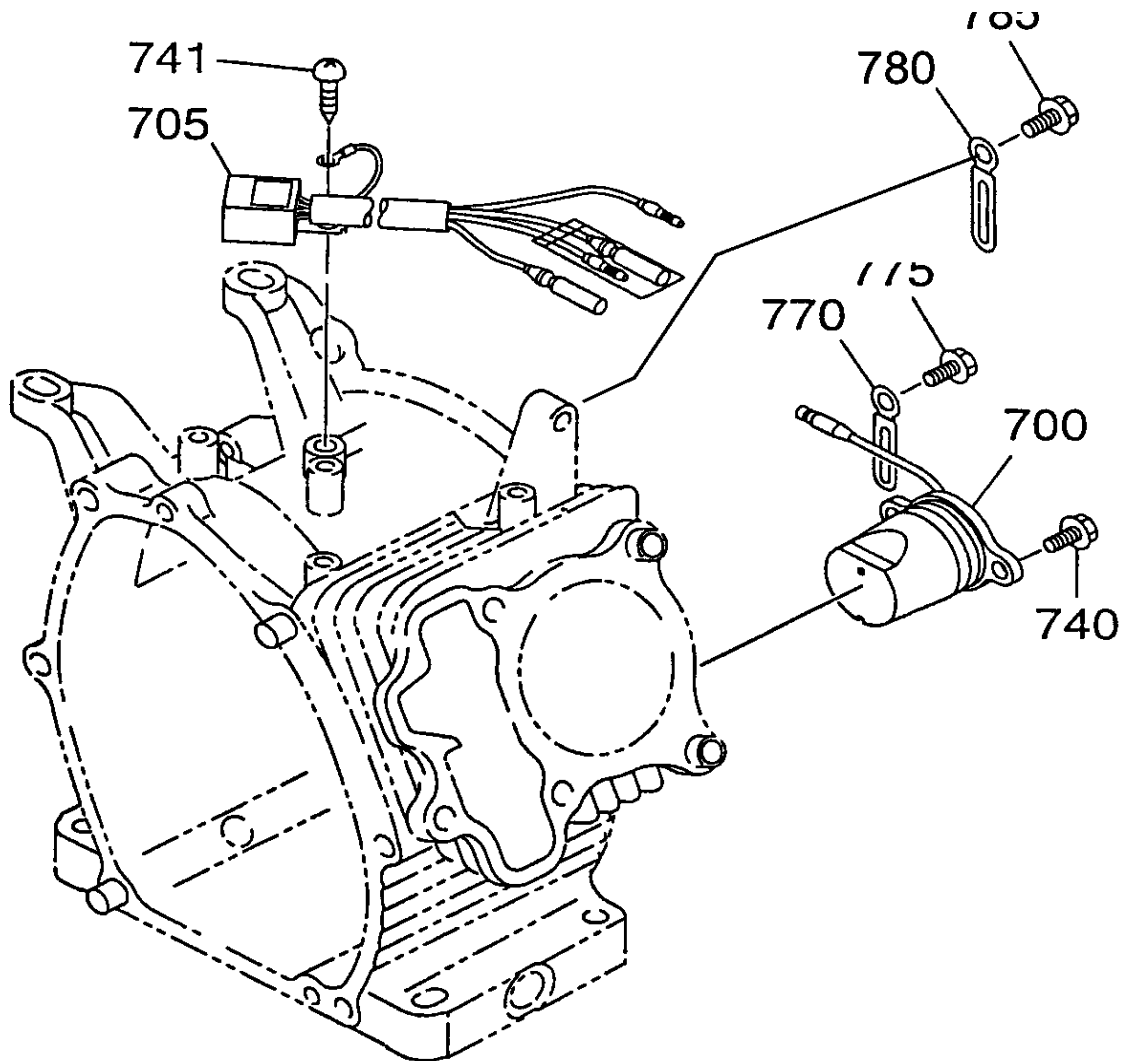

ROBIN EX270D20110 — FLYWHEEL ASSY.

FLYWHEEL ASSY.

<u>NO</u>	<u>PART NO</u>	<u>PART NAME</u>	<u>QTY.</u>	<u>REMARKS</u>
10	2797923001	FLYWHEEL CP	1	
11	2797943001	IGNITION COIL CP	1	
30	0011406250	BOLT & WASHER ASSY.	2	
50	27773102H1	WIRE 2 CP, W/OIL SENSOR	1	
60	0660000371	SWITCH ASSY.	1	
70	0150040090	TAPPING SCREW	2	
100	0650140150	SPARK PLUG	1.....	NGK BR6HS
110	0655000270	SPARK PLUG CAP	1	

ROBIN EX270D20110 — ELECTRIC DEVICE ASSY.

ELECTRIC DEVICE ASSY.

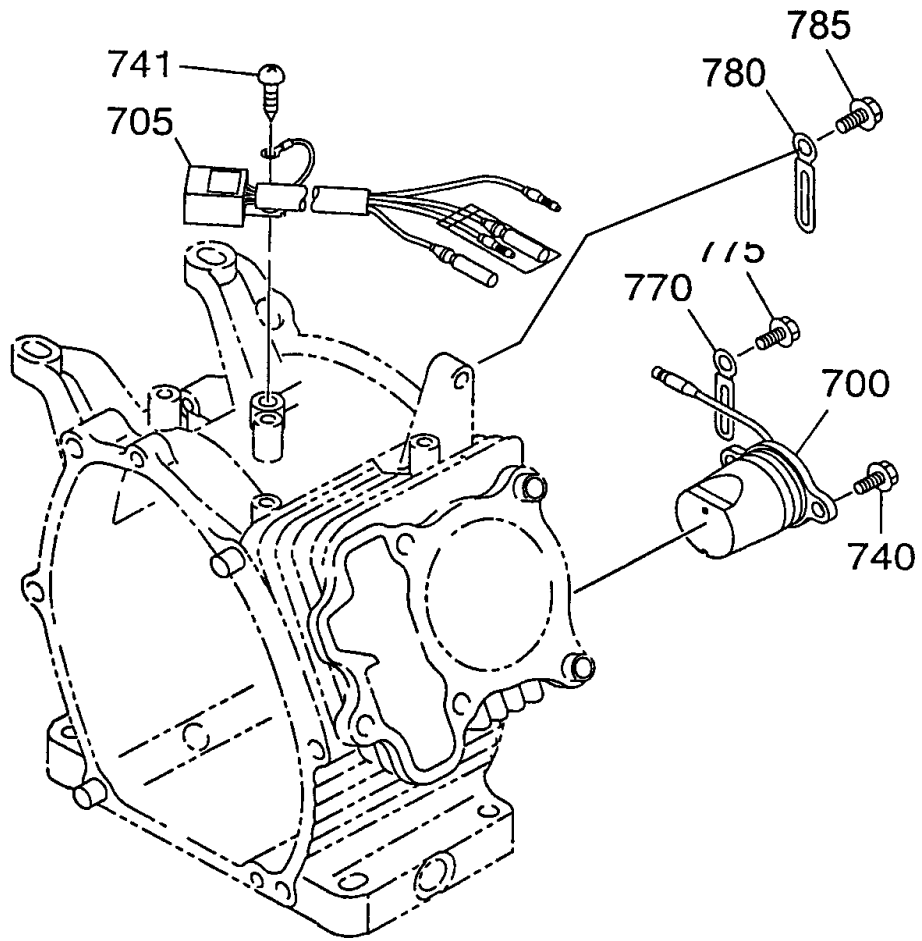

ROBIN EX270D20110 — ELECTRIC DEVICE ASSY.

ELECTRIC DEVICE ASSY.

<u>NO</u>	<u>PART NO</u>	<u>PART NAME</u>	<u>QTY.</u>	<u>REMARKS</u>
700	2797630131	OIL SENSOR CP	1	
705	KU31107001	FLOAT, C/U CP3	1	
740	0011406160	BOLT & WASHER ASSY.	2	
740	0011406160	BOLT & WASHER ASSY.	2	
741	0150040090	TAPPING BOLT	1	
770	2147900601	CLAMP CP	1	
775	0110060020	FLANGE BOLT	1	
780	2797550103	CLAMP	1	
785	0152060050	TAPPING BOLT	1	

STOW

A DIVISION OF MULTIQUIP INC.

Terms and Conditions of Sale STOW Construction Equipment

PAYMENT TERMS

Terms of payment for unit sales are 2% 15 days net 30 days from date of invoice unless otherwise specifically stated on our invoice. Parts invoices have terms of net 10 days. **Minimum parts billing is \$15.00 net.**

Applicable discounts will be computed on merchandise value only. Late charges will be assessed at prevailing rates. Cash discounts cannot be taken on current billings if any previously billed amounts are past due.

FREIGHT POLICY

Freight policy is established to offer customers every advantage possible. Due to bulk freight ratings on some equipment and other shipping considerations, freight policies differ by equipment type. Actual back freight may be charged for shipments originating from other than specified FOB warehouses. **See Freight Policy for details.**

All STOW domestic sales are FOB nearest available designated MQ/STOW warehouse. Export orders are ex-works factory located in Carson, CA or Boise, ID.

Additions to orders already shipped cannot be accepted for freight minimums.

Should STOW elect to make partial shipments of an order originally complying with the "freight allowed" requirements, transportation charges will be absorbed by STOW on any subsequent shipment applying to that order.

All other orders will be shipped collect or prepaid with charges added to the invoice. STOW's responsibility ceases when a signed manifest has been obtained from the carrier, and any claim for shortage or damage must be settled between the consignee and the carrier.

Parts: FOB Carson, California or Boise, Idaho. **See Freight Policy for details and additional discounts.**

DROP SHIPMENTS

STOW reserves the right to refuse Drop Shipments outside the normal service area of the purchasing dealer.

FIELD WAREHOUSES

Field Warehouses are currently located in California, Georgia, Idaho, Iowa, and New Jersey

SPECIAL EXPEDITING SERVICE

The higher of a \$35.00 surcharge or actual costs will be added to the invoice for special handling, including bus shipments, or in cases where STOW personnel must personally deliver the equipment or parts to the carrier.

RETURNED GOODS POLICY

Return shipments may be accepted and credit allowed, subject to the following provisions.

1. A Returned Material Authorization (RMA) must be approved by STOW prior to shipment. Approvals for returned goods must be with just cause and are at the sole discretion of STOW. A copy of the Authorization must accompany the shipment to the designated Warehouse.
2. Parts being returned must be listed as currently supplied on the current parts list.
3. Parts must be in new and resalable condition in the original package, with part numbers clearly marked.
4. Units and accessories must be current models in the latest price list and in new and resalable condition.
5. Special order items are not returnable for credit.
6. Credit on returned parts and units will be issued at actual dealer net price at time of purchase less 15% restocking charge.
7. All returned shipments are to be made to the STOW designated receiving point, freight prepaid at the sender's expense.

The sender will be notified of any material received that does not meet the above provisions. Such material will be held for 30 days from notification pending instructions. If a reply is not received within 30 days, the material will be returned to the sender at his expense with no credit issued.

PRICING, REBATES AND SPECIFICATIONS

Every effort will be made to provide adequate notice of changes; however, prices and equipment specifications are subject to change without notice.

Price changes are effective on a specific date and all orders received on or after that date will be billed at the revised price.

Rebates for price reductions and added charges for price increases will not be made for stock in dealer inventory at the time of a price change. STOW reserves the right to quote and sell direct to Government agencies and to Original Equipment Manufacturer accounts who use our products as integral parts of their own products.

LIMITATION OF SELLER'S LIABILITY

STOW shall not be liable hereunder for damages in excess of the purchase price of the item with respect to which damages are claimed and in no event shall STOW be liable for loss of profit or good will or for any other special, consequential or incidental damages.

LIMITATION OF WARRANTIES

There are no warranties, express or implied, made by STOW hereunder on Products manufactured or distributed by it except the warranty against defects in material and workmanship on new Products to the original purchaser, as set forth in the STOW New Product Limited Warranty.

STOW

A DIVISION OF MULTIQUIP INC.

Atlanta • Boise • Newark • Quebec, Canada
Manchester, UK • Rio de Janeiro, BR • Puebla, MX

STOW CONSTRUCTION EQUIPMENT

POST OFFICE BOX 6254
CARSON, CALIFORNIA 90749
310-661-4242 • 877-BUY-STOW
FAX: 310-604-9237
E-MAIL: stow@stowmfg.com
www.stowmfg.com

OPERATION AND PARTS MANUAL

HERE'S HOW TO GET HELP

PLEASE HAVE THE MODEL AND SERIAL
NUMBER *ON-HAND* WHEN CALLING

PARTS DEPARTMENT

800-427-1244 FAX: 800-672-7877

310-537-3700 FAX: 310-637-3284

SERVICE DEPARTMENT

800-478-1244 FAX: 310-537-4259

310-537-3700

TECHNICAL ASSISTANCE

800-478-1244 FAX: 310-631-5032

WARRANTY DEPARTMENT

800-421-1244, EXT. 279 FAX: 310-537-1173

310-537-3700, EXT. 279

SALES DEPARTMENT

310-661-4242 FAX: 310-604-9237

877-289-7869 (877-BUY-STOW)

Manufactured for MULTIQUIP INC.
by
DENYO MANUFACTURING CO., JAPAN

STOW
A DIVISION OF MULTIQUIP INC.

STOW CONSTRUCTION EQUIPMENT

A DIVISION OF MULTIQUIP INC.

POST OFFICE BOX 6254

CARSON, CA 90749

310-537-3700 • 888-252-STOW [888-252-7869]

FAX: 310-537-1986 • FAX: 800-556-1986

E-MAIL: stow@multiquip.com • WWW: stowmfg.com

PARTS DEPARTMENT:

800-427-1244

FAX: 800-672-7877

SERVICE DEPARTMENT/TECHNICAL ASSISTANCE:

800-478-1244

FAX: 310-631-5032