

# OPERATION AND PARTS MANUAL

# MQ POWER DCA-125SSJU2 WHISPERWATT™ GENERATOR (FEMA)



PARTS LIST NO. 3870300064A  
FROM S/N 7500508~

Revision #1 (06/03/03)



**MULTIQUIP INC.**

18910 WILMINGTON AVE.  
CARSON, CALIFORNIA 90746  
310-537-3700  
800-421-1244  
FAX: 310-537-3927

E-mail: [mq@multiquip.com](mailto:mq@multiquip.com) • [www.multiquip.com](http://www.multiquip.com)

**PARTS DEPARTMENT:**

800-427-1244  
FAX: 800-672-7877

**SERVICE DEPARTMENT:**

800-835-2551  
FAX: 310-638-8046



# **WARNING**



## **CALIFORNIA--Proposition 65 Warning**

**Engine exhaust and some of its constituents are known to the State of California to cause cancer, birth defects and other reproductive harm.**

## **HERE'S HOW TO GET HELP**

*PLEASE HAVE THE MODEL AND SERIAL  
NUMBER ON-HAND WHEN CALLING*

### ***PARTS DEPARTMENT***

*800-427-1244 or 310-537-3700*

*FAX: 800-672-7877 or 310-637-3284*

### ***SERVICE DEPARTMENT***

*800-421-1244*

*FAX: 310- 537-4259*

### ***TECHNICAL ASSISTANCE***

*800-478-1244*

*FAX: 310- 631-5032*

### ***WARRANTY DEPARTMENT***

*888-661-4279, or 310-661-4279*

*FAX: 310- 537-1173*

**MQ POWER DCA-125SSJU2  
AC GENERATOR (FEMA)**

Here's How To Get Help ..... 2  
 Parts Ordering Procedures ..... 3  
 Table Of Contents ..... 4  
 Parts Ordering Procedures ..... 5  
 Specifications ..... 6  
 Dimensions (Top, Side and Front) ..... 7  
 Safety Message Alert Symbols ..... 8-9  
 Rules for Safe Operation ..... 10-12  
 Installation ..... 14-15  
 Generator Decals ..... 16-17  
 General Information ..... 18  
 Major Components ..... 19  
 Generator Control Panel ..... 20  
 Engine Operating Panel ..... 22-23  
 Output Terminal Panel Familiarization ..... 24-26  
 Load Application ..... 27  
 Generator Outputs ..... 28-29  
 Guage Reading ..... 29  
 Output Terminal Panel Connections ..... 30-31  
 Pre-Setup ..... 32-35  
 Generator Start-up Procedure (Manual) ..... 36-38  
 Generator Start-up Procedure (Auto Mode) ..... 39  
 Generator Shut-down Procedure ..... 40  
 Maintenance ..... 42-43  
 Generator Wiring Diagram ..... 44  
 Engine Wiring Diagram (MPEC Controller) ..... 45  
 Engine Troubleshooting ..... 46-47  
 Generator Troubleshooting ..... 48  
 Engine Controller Troubleshooting (MPEC) ..... 49  
 Explanation of Codes in Remarks Column ..... 50  
 Suggested Spare Parts ..... 51

**COMPONENT DRAWINGS**

Name Plate And Decals ..... 52-53  
 Generator Assembly ..... 54-57  
 Control Box Assembly ..... 58-61  
 Engine & Radiator Assembly ..... 62-65  
 Engine Operating Panel Assembly ..... 66-67  
 Output Terminal Assembly ..... 68-69  
 Battery Assembly ..... 70-71  
 Muffler Assembly ..... 72-73  
 Enclosure Assembly ..... 74-77  
 Rubber Seal Assembly ..... 78-79  
 Fuel Tank Assembly ..... 80-81  
 Battery Charger Assembly ..... 82-83  
 Camlock Panel Assembly ..... 84-85  
 Terms and Condition of Sale — Parts ..... 86

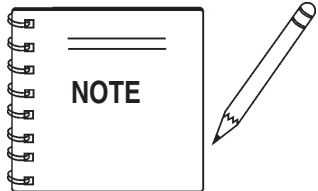

*Specification and part number are subject to change without notice.*

# PARTS ORDERING PROCEDURES

## When ordering parts, please supply the following information:

- Dealer account number
- Dealer name and address
- Shipping address (if different than billing address)
- Return fax number
- Applicable model number
- Quantity, part number and description of each part
- Specify preferred method of shipment:
  - ✓ FedEx or UPS Ground
  - ✓ FedEx or UPS Second Day or Third Day
  - ✓ FedEx or UPS Next Day
  - ✓ Federal Express Priority One
  - ✓ DHL
  - ✓ Truck

*Note: Unless otherwise indicated by customer, all orders are treated as "Standard Orders", and will ship within 24 hours. We will make every effort to ship "Air Shipments" the same day that the order is received, if prior to 2PM west coast time. "Stock Orders" must be so noted on fax or web forms.*



## Here's how to get help...

*Please have the model and serial number on hand when calling.*

### Parts Department

800-427-1244 Fax: 800-672-7877  
310-537-3700 Fax: 310-637-3284

### Mayco Parts

800-306-2926 Fax: 800-672-7877  
310-537-3700 Fax: 310-637-3284

### Service Department

800-478-1244 Fax: 310-537-4259  
310-537-3700

### MQ Power Service Department

800-835-2551 Fax: 310-638-8046  
310-537-3700

### Warranty Department

800-421-1244, Ext. 279 Fax: 310-537-1173  
310-537-3700, Ext. 279

### Multiquip's Main Phone Numbers

800-421-1244 Fax: 310-537-3927  
310-537-3700

## Place Your Parts Order Via Web or Fax For Even More Savings!

### Extra Discounts!

All parts orders which include complete part numbers and are received by our automated web parts order system, or by fax qualify for the following extra discounts:

Ordered via	Standard orders	Stock orders (\$750 list and above)
Fax	3%	10%
Web	5%	10%

### Special freight allowances when you order 10 or more line items via Web or Fax! \*\*

FedEx Ground Service **at no charge for freight**  
No other allowances on freight shipped by any other carrier.

NOTE: DISCOUNTS ARE SUBJECT TO CHANGE



**MULTIQUIP INC.**  
18910 WILMINGTON AVENUE  
POST OFFICE BOX 6254  
CARSON, CALIFORNIA 90749  
310-537-3700 • 800-421-1244  
FAX: 310-537-3927  
E-MAIL: mq@multiquip.com  
WWW: multiquip.com

**Direct TOLL-FREE access  
to our Parts Department:**

Toll-free nationwide — 800-427-1244

# DCA-125SSJU2 — SPECIFICATIONS

<b>Table 1. Generator Specifications</b>		
<b>Model</b>	<b>DCA-125SSJU2</b>	
<b>Type</b>	Revolving field, self ventilated, drip proof single bearing	
<b>Armature Connection</b>	Star with Neutral/Zig Zag	
<b>Voltage 3-Phase</b>	208, 220, 240, 416, 440, 480V switchable	
<b>Voltage Single-Phase</b>	120, 127, 139, 240, 254, 277V switchable	
<b>Standby Output</b>	137.5 KVA (110 KW)	
<b>Prime Output</b>	125 KVA (100 KW)	
<b>Frequency</b>	60 Hz	
<b>Speed</b>	1800 rpm	
<b>Power Factor</b>	0.8	
<b>Sound Level dB (A) Full Load at 23 feet</b>	67	
<b>Insulation</b>	Class F	
<b>Engine Specifications</b>		
<b>Model</b>	<b>JOHN DEERE 6068TF250</b>	
<b>Type</b>	4 Cycle, water-cooled, direct injection, turbo-charged	
<b>No. of Cylinders</b>	6 cylinders	
<b>Bore x Stroke</b>	(106 mm x 127 mm)	
<b>Rated Output</b>	150 HP/1800 rpm	
<b>Displacement</b>	410 cu. in. (6724 cc)	
<b>Starting</b>	Electric	
<b>Coolant Capacity</b>	10.3 gal. (39 liters)	
<b>Lube Oil Capacity</b>	4.5 gal. (17 liters)	
<b>Fuel Consumption</b>	7.5 gal (28.4 liters)/hr at <b>full load</b>	5.7 gal (21.6 liters)/hr at <b>3/4 load</b>
	4.0 gal (15 liters)/hr at <b>1/2 load</b>	2.3 gal (8.7 liters)/hr at <b>1/4 load</b>
<b>Battery</b>	12V- 150 AH x1	
<b>Fuel</b>	#2 Diesel Fuel	

# DCA-125SSJU2 — DIMENSIONS (TOP, SIDE, REAR)

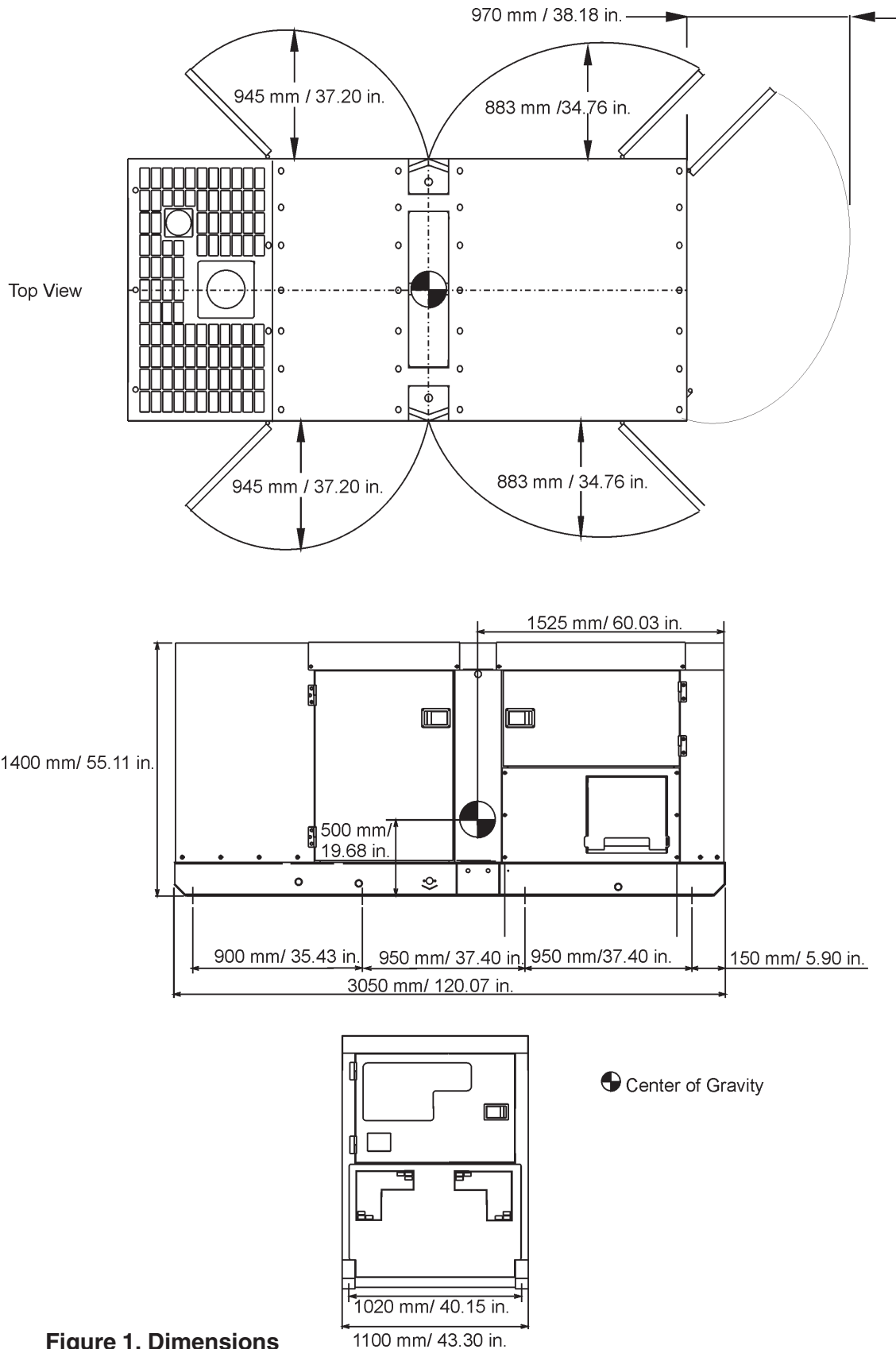
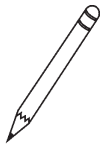
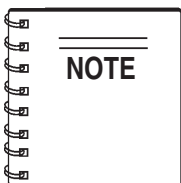

**Figure 1. Dimensions**

# DCA-125SSJU2 — SAFETY MESSAGE ALERT SYMBOLS

## FOR YOUR SAFETY AND THE SAFETY OF OTHERS!

Safety precautions should be followed at all times when operating this equipment. Failure to read and understand the Safety Messages and Operating Instructions could result in injury to yourself and others.



This Owner's Manual has been developed to provide complete instructions for the safe and efficient operation of the MQ Power *Model DCA125SSJU2 WHISPERWATT™ GENERATOR*.

**Before using this GENERATOR, ensure that the operating individual has read and understands all instructions in this manual.**

## SAFETY MESSAGE ALERT SYMBOLS

The three (3) Safety Messages shown below will inform you about potential hazards that could injure you or others. The Safety Messages specifically address the level of exposure to the operator, and are preceded by one of three words: **DANGER**, **WARNING**, or **CAUTION**.



**DANGER:** You **WILL** be **KILLED** or **SERIOUSLY** injured if you **DO NOT** follow directions.



**WARNING:** You **CAN** be **KILLED** or **SERIOUSLY** injured if you **DO NOT** follow directions.



**CAUTION:** You **CAN** be injured if you **DO NOT** follow directions.

Potential hazards associated with trowel operation will be referenced with "**Hazard Symbols**" which appear throughout this manual, and will be referenced in conjunction with Safety "**Message Alert Symbols**".

## HAZARD SYMBOLS



### Lethal Exhaust Gases



Engine exhaust gases contain poisonous carbon monoxide. This gas is colorless and odorless, and can cause death if inhaled. **NEVER** operate this equipment in a confined area or enclosed structure that does not provide ample free flow air.



### Explosive Fuel



Diesel fuel is extremely flammable, and its vapors can cause an explosion if ignited. **DO NOT** start the engine near spilled fuel or combustible fluids. **DO NOT** fill the fuel tank while the engine is running or hot. **DO NOT** overfill tank, since spilled fuel could ignite if it comes into contact with hot engine parts or sparks from the ignition system. Store fuel in approved containers, in well-ventilated areas and away from sparks and flames. **NEVER** use fuel as a cleaning agent.



### Burn Hazards



Engine components can generate extreme heat. To prevent burns, **DO NOT** touch these areas while the engine is running or immediately after operations. **NEVER** operate the engine with heat shields or heat guards removed.



### Rotating Parts



**NEVER** operate equipment with covers, or guards removed. Keep **fingers, hands, hair** and **clothing** away from all moving parts to prevent injury.

# DCA-125SSJU2 — SAFETY MESSAGE ALERT SYMBOLS



## Accidental Starting



**OFF** **ALWAYS** place the engine ON/OFF switch in the **OFF** position, when the trowel is not in use.



## Respiratory Hazard



**ALWAYS** wear approved respiratory protection.



## Over Speed Conditions



**NEVER** tamper with the factory settings of the engine governor or settings. Personal injury and damage to the engine or equipment can result if operating in speed ranges above maximum allowable.



## Sight and Hearing hazard

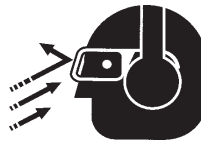

**ALWAYS** wear approved eye and hearing protection.

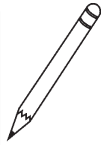
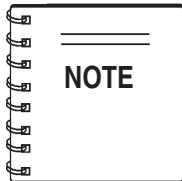

This **generator**, other property, or the surrounding environment could be damaged if you do not follow instructions.



## Equipment Damage Messages

Other important messages are provided throughout this manual to help prevent damage to your trowel, other property, or the surrounding environment.

# DCA-125SSJU2 — RULES FOR SAFE OPERATION

## CAUTION:



Failure to follow instructions in this manual may lead to serious injury or even death! This equipment is to be operated by trained and qualified personnel only! This equipment is for industrial use only.

The following safety guidelines should always be used when operating the **DCA-125SSJU2 Generator**:

### GENERAL SAFETY

- **DO NOT** operate or service this equipment before reading this entire manual.



- This equipment should not be operated by persons under 18 years of age.

- **NEVER** operate this equipment without proper protective clothing, shatterproof glasses, steel-toed boots and other protective devices required by the job.



- **NEVER** operate this equipment when not feeling well due to fatigue, illness or taking medicine.



- **NEVER** operate this equipment under the influence of drugs or alcohol.



- **NEVER** use accessories or attachments, which are not recommended by MQ Power for this equipment. Damage to the equipment and/or injury to user may result.

- Manufacture does not assume responsibility for any accident due to equipment modifications.

- Whenever necessary, replace nameplate, operation and safety decals when they become difficult read.

- **ALWAYS** check the machine for loosened threads or bolts before starting.

- **NEVER** operate the generator in an explosive atmosphere or near combustible materials. An explosion or fire could result causing severe **bodily harm or even death**.

- **NEVER** touch the hot exhaust manifold, muffler or cylinder. Allow these parts to cool before servicing engine or generator.

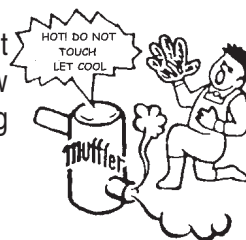

- **High Temperatures** – Allow the engine to cool before performing service and maintenance functions. Contact with **hot!** components can cause serious burns.

- The engine of this generator requires an adequate free flow of cooling air. **NEVER** operate the generator in any enclosed or narrow area where free

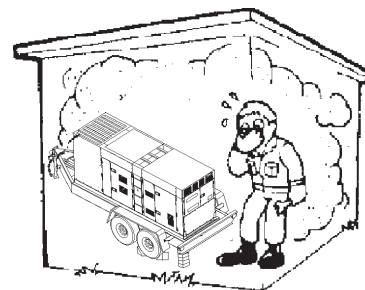

flow of the air is restricted. If the air flow is restricted it will cause serious damage to the generator or engine and may cause injury to people. The generator engine gives off **DEADLY** carbon monoxide gas.

- **ALWAYS** make sure generator is properly grounded.

- **NEVER** use gas piping as an electrical ground.

- **DO NOT** place hands or fingers inside generator engine compartment when engine is running.

- **ALWAYS** make sure generator installation is accordance with **national and local electrical codes**.

- **ALWAYS** have a qualified electrician perform the generator wiring installation.

- **NEVER** power cables or cords **lay in water**.

- **NEVER stand in water** while AC power from the generator is being transfer to a load.

- **NEVER** use a defective or frayed power cable. Check the cable for cuts in the insulation.

- **NEVER** use a extension cord that is frayed or damaged where the insulation has been cut.

- **ALWAYS** make certain that proper extension cord has been selected for the job See Table 4.

- The electrical voltage required to operate the generator can cause severe injury or even death through physical contact with live circuits. Turn all circuit breakers **OFF** before performing maintenance on the generator.

# DCA-125SSJU2 — RULES FOR SAFE OPERATION

■ **ALWAYS** make sure that electrical circuits are properly **grounded** per the **National Electrical Code (NEC)** and local codes before operating generator. Severe **injury** or **death!** by electrocution can result from operating an ungrounded generator.

■ **ALWAYS** be sure the operator is familiar with proper safety precautions and operations techniques before using generator.

■ **ALWAYS** store equipment properly when it is not being used. Equipment should be stored in a clean, dry location out of the reach of children.

■ **ALWAYS** read, understand, and follow procedures in Operator's Manual before attempting to operate equipment.



## DANGER:



**Never** use damaged or worn cables when connecting equipment to the generator. Make sure power connecting cables are securely connected to the generator's output terminals, insufficient tightening of the terminal connections may cause damage to the generator and electrical shock.



## DANGER:



**NEVER** grab or touch a live power cord with wet hands, the possibility exists of electrical shock, electrocution, and even **death!**

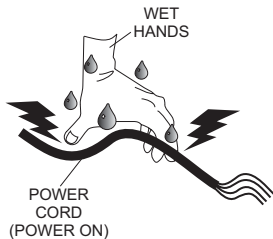

## DANGER:

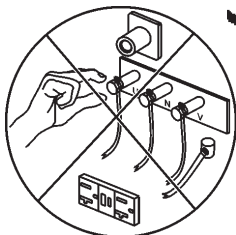

■ **NEVER** touch output terminals during operation. This is extremely dangerous. **ALWAYS** stop the machine and place the circuit breaker in the "OFF" position when contact with the output terminals is required. There exists the possibility of **electrocution, electrical shock or burn, which can cause severe bodily harm or even death!**

## DANGER:

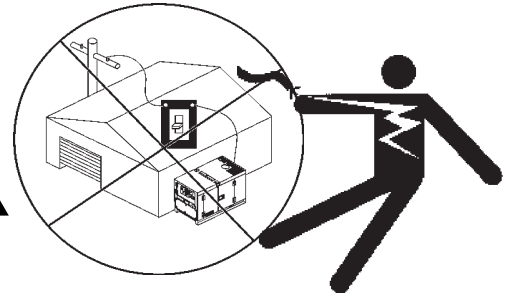
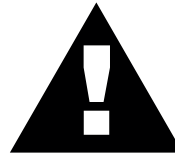

■ Backfeed to a utility system can cause **electrocution** and or property damage. **DO NOT** connect to any building's electrical system except through an approved device or after building main switch is opened. **ALWAYS** have a licensed electrician perform the installation

## CAUTION:



**DO NOT** touch or open any of the below mentioned components while the generator is running. Always allow sufficient time for the engine and generator to cool before performing maintenance.

### Radiator

1. **Radiator Cap** - Removing the radiator cap while the engine is hot will result in high pressurized, boiling water to gush out of the radiator, causing severe scalding to any persons in the general area of the generator.
2. **Coolant Drain Plug** - Removing the coolant drain plug while the engine is hot will result in hot coolant to gush out of the coolant drain plug, therefore causing severe scalding to any persons in the general area of the generator.
3. **Engine Oil Drain Plug** - Removing the engine oil drain plug while the engine is hot will result in hot oil to gush out of the oil drain plug, therefore causing severe scalding to any persons in the general area of the generator.

### Maintenance Safety

■ **NEVER** lubricate components or attempt service on a running machine.

■ **ALWAYS** allow the machine a proper amount of time to cool before servicing.



■ Keep the machinery in proper running condition.

■ Fix damage to the machine immediately and always replace broken parts.

# DCA-125SSJU2 — RULES FOR SAFE OPERATION

- **NEVER** Run engine without air filter. Severe engine damage may occur.
- **ALWAYS** service air cleaner frequently to prevent engine malfunction.
- **ALWAYS** disconnect the **negative battery terminal** before performing service on the generator.
- **ALWAYS** be sure the operator is familiar with proper safety precautions when operating the generator set.
- **ALWAYS** store equipment properly when not in use.
- **DO NOT** leave the generator running in the **manual mode** unattended.
- **DO NOT** allow unauthorized people to operate this equipment.
- **ALWAYS** read, understand, and follow procedures in Operator's Manual before attempting to operate equipment.
- Refer to the **John Deere Engine Manual** for engine technical questions or information.

## DANGER:



Pay close attention to ventilation when operating the generator inside tunnels and caves. The engine exhaust contains noxious elements. Engine exhaust must be routed to a ventilated area.



## Generator Grounding

To guard against electrical shock and possible damage to the equipment, it is important to provide a good **EARTH** ground.

Article 250 (Grounding) of the **National Electrical Code** (NEC) provides guide lines for proper grounding and specifies that the cable ground shall be connected to the grounding system of the building as close to the point of cable entry as practical.

**ALWAYS** be sure to use the ground terminal (green wire) when connecting a load to the UVWO output terminals.

## Battery

The battery contains acids that can cause injury to the eyes and skin. To avoid eye irritation, **always** wear safety glasses. Use well insulated gloves when picking up the battery. Use the following guidelines when handling the battery:

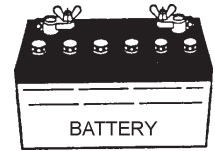

1. **DO NOT** drop the battery. There is the possibility of risk that the battery may explode.
2. **DO NOT** expose the battery to open flames, sparks, cigarettes etc. The battery contains combustible gases and liquids. If these gases and liquids come in contact with a flame or spark, an explosion could occur.
3. **ALWAYS** keep the battery charged. If the battery is not charged a buildup of combustible gas will occur.
4. **ALWAYS** keep battery charging and cables in good working condition. Repair or replace all worn cables.
5. **ALWAYS** recharge the battery in an vented air environment, to avoid risk of a dangerous concentration of combustible gases.
6. In case the battery liquid (dilute sulfuric acid) comes in contact with **clothing or skin**, rinse skin or clothing immediately with plenty of water.
7. In case the battery liquid (dilute sulfuric acid) comes in contact with your **eyes**, rinse eyes immediately with plenty of water, then contact the nearest doctor or hospital, and seek medical attention.

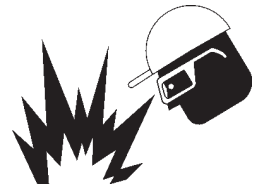

## Emergencies

- **ALWAYS** know the location of the nearest **fire extinguisher** and **first aid kit**.



- In emergencies **always** know the location of the nearest phone or **keep a phone on the job site**. Also know the phone numbers of the nearest **ambulance**, **doctor** and **fire department**. This information will be invaluable in the case of an emergency.





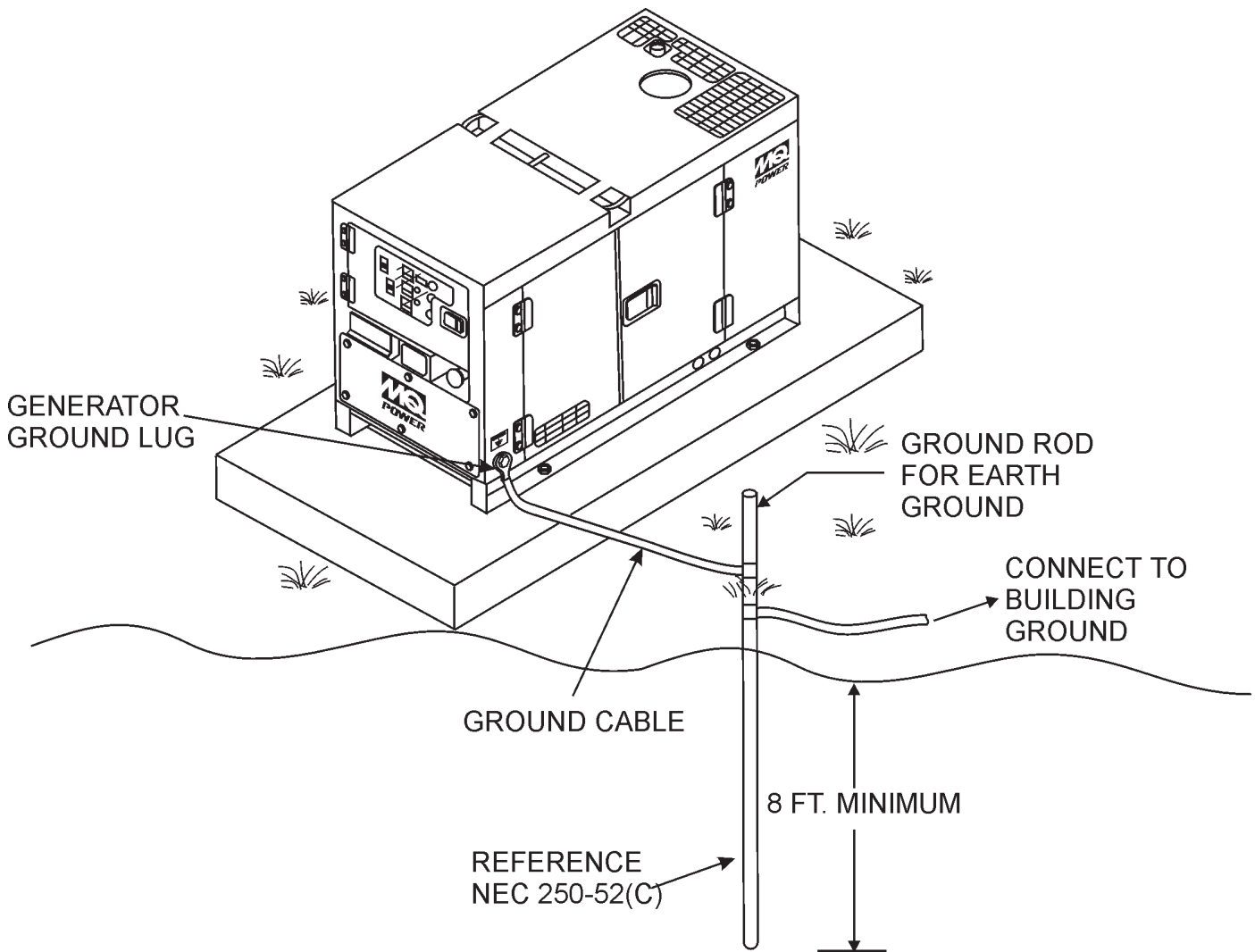

Figure 2. Typical Generator Grounding Application

## Outdoor Installation

Install the generator in a area that is free of debris, bystanders, and overhead obstructions. Make sure the generator is on secure level ground so that it cannot slide or shift around. Also install the generator in a manner so that the exhaust will not be discharged in the direction of nearby homes.

The installation site must be relatively free from moisture and dust. All electrical equipment should be protected from excessive moisture. Failure to do will result in deterioration of the insulation and will result in short circuits and grounding.

Foreign materials such as dust, sand, lint and abrasive materials have a tendency to cause excessive wear to engine and alternator parts.

## CAUTION:



Pay close attention to ventilation when operating the generator inside tunnels and caves. The engine exhaust contains noxious elements. Engine exhaust must be routed to a ventilated area.

## Indoor Installation

Exhaust gases from diesel engines are extremely poisonous. Whenever an engine is installed indoors the exhaust fumes must be vented to the outside. The engine should be installed at least two feet from any outside wall. Using an exhaust pipe which is too long or too small can cause excessive back pressure which will cause the engine to heat excessively and possibly burn the valves.

## Mounting

The generator must be mounted on a solid foundation (such as concrete) and set firmly on the foundation to isolate vibration of the generator when it is running. The generator must set at least 6 inches above the floor or grade level (in accordance to NFPA 110, Chapter 5-4.1). **DO NOT** remove the metal skids on the bottom of the generator. They are to resist damage to the bottom of the generator and to maintain alignment.

## Generator Grounding

To guard against electrical shock and possible damage to the equipment, it is important to provide a good **EARTH** ground.

Article 250 (Grounding) of the National Electrical Code (NEC) provides guide lines for proper grounding and specifies that the cable ground shall be connected to the grounding system of the building as close to the point of cable entry as practical.

NEC articles 250-64(b) and 250-66 set the following grounding requirements:

1. Use one of the following wire types to connect the generator to earth ground.
  - a. Copper - 10 AWG (5.3 mm<sup>2</sup>) or larger.
  - b. Aluminum - 8 AWG (8.4 mm<sup>2</sup>) or larger.
2. When grounding the generator (Figure 2) connect the ground cable between the lock washer and the nut on the generator and tighten the nut fully. Connect the other end of the ground cable to earth ground.
3. NEC article 250-52(c) specifies that the earth ground rod should be buried a minimum of 8 ft. into the ground.

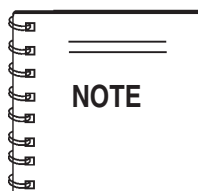

When connecting the generator to any buildings electrical system **ALWAYS** consult with a licensed electrician.

# DCA-125SSJU2 — GENERATOR DECALS

The DCA-125SSJU2 generator is equipped with a number of safety decals (Figure 3). These decals are provided for operator safety and maintenance information. The illustration below and on the preceding page show the decals as they appear on the machine. Should any of these decals become unreadable, replacements can be obtained from your dealer.

**OPERATING PROCEDURES**

**Manual Starting**

1. Check the engine oil, coolant, and fuel levels. Replenish if necessary.
2. Place all Generator Circuit Breakers in the "OFF" position and close all doors.
3. Check that the Voltage select switch (or the Voltage change-over board) is present at desired voltage. (In case of generator having multiple voltage ratings.)
4. Set the Engine speed switch to the "LOW" position.
5. Turn the Auto-Off/Reset-Manual switch to the "Manual" position to start the engine. If the engine fails to start in the specified number of attempts, the overcrank lamp will indicate and the Auto-Off/Reset-Manual switch must be returned to the "Off/Reset" position before proceeding.
6. When the engine is ready for starting during cold weather operating conditions, push the intake heater button for approximately 30 seconds. Start engine using the Auto-Off/Reset-Manual switch to the "Manual" position. As soon as the engine starts, release the button. If the engine still does not start, utilize the water heater until water is warm. (If additional water heater is supplied.)
7. After starting, allow the engine to run for 1 or 2 minutes to warm-up. At temperatures below freezing, this time period must be extended to 2 to 4 minutes.
8. When the engine starts, immediately check for abnormal noise, vibration, fluid leakage or any indication of a problem. Check the control panel gauges. If all is normal, let the engine remain at the "Low" position for a short time, depending on the ambient conditions, warm up.
9. After sufficient warm-up time has elapsed, set the Engine speed switch to the "High" position and the unit is ready for operation.
10. Check the No-Load speed as shown in the table below.  
80% operation—Approx. 60 Ors (1000rpm)
11. Adjust the Voltage Regulator to the specified voltage.

**Manual Stopping**

1. Place the Generator Circuit Breakers in the "OFF" position.
2. Set the Engine speed switch to the "LOW" position, and allow the unit to cool for a few minutes.
3. Turn the Auto-Off/Reset-Manual switch, to the "Off/Reset" position.

**Auto Starting/Stopping**

1. With the Auto/Manual switch in the Auto position, the Auto Starting/Stopping controller monitors remote start contacts. Closure of this remote start contacts will begin engine cranking. When the contacts are opened cranking will stop or if running the engine will stop. All functions to the Automatic shutdown System work as in Manual Starting/stopping.
2. For cold weather conditions utilize the water heater until water is warm. If the engine still does not start, please operate as in Manual Starting.

**Emergency Stopping**

1. Place the Generator Circuit Breakers in the "OFF" position.
2. Turn the Auto-Off/Reset-Manual switch to the "Off/Reset" position.

M35200010

**P/N M3552000103**

**SAFETY INSTRUCTIONS**

Improper operation of this machine can cause severe injury or death.

- Read the instruction manual carefully before operating or servicing.

This machine should only be operated by a person with sufficient knowledge and skill to ensure safe operation.

High voltage circuits are located inside the output terminal cover and control panel.

- Close the cover and control panel before operating.

Moving parts and hot surfaces are contained within the enclosure.

- Close all doors and lock them before operating.

M92010030

**P/N M9520100304**

**OIL DRAIN PLUG** ↓

M9000000

**P/N M950000004**

**OVER CURRENT RELAY**

If it is Impossible to reset the CIRCUIT BREAKER, open the control panel and push the RESET BUTTON as below.

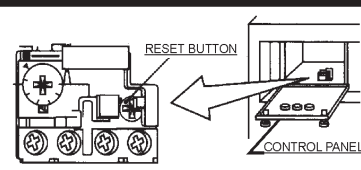

M92020010

**P/N M9520200104**

**FUEL DRAIN PLUG** ↓

M90050010

**P/N M9500500104**

**WATER • OIL CHECK AND FILL DAILY**

M90300010

**P/N M9503000103**

**Denyo**

**MQ**

**POWER**

M920100000

**P/N M9510200002**

+++

P/N M9500300104

---

P/N M9500300004

**DIESEL FUEL**

M90050000

**P/N M9500500004**

Figure 3. Generator Decals

# DCA-125SSJU2 — GENERATOR DECALS

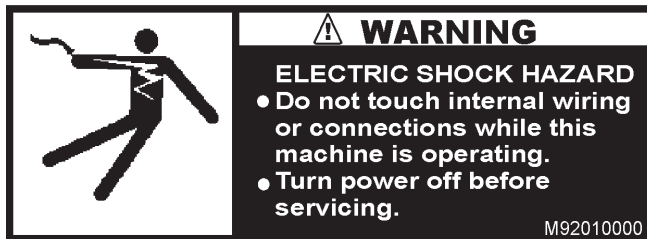

P/N M9520100004

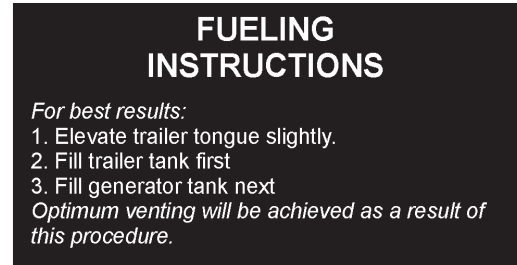

P/N TBD

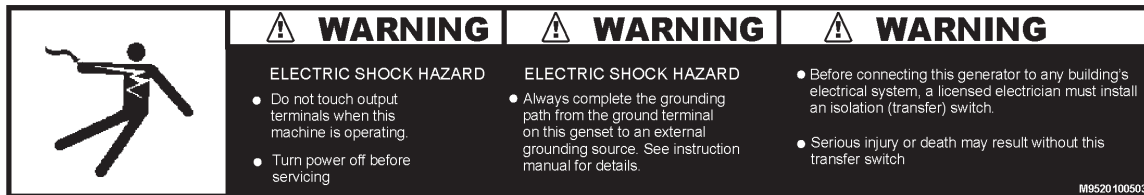

P/N M9520100503

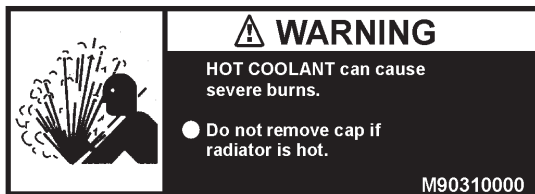

P/N M9503100004

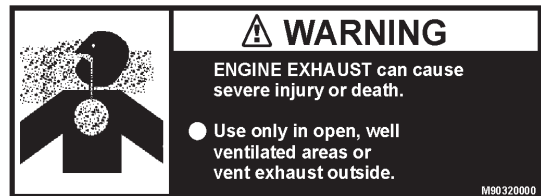

P/N M9503200004



P/N M9520100404



P/N M9520100204

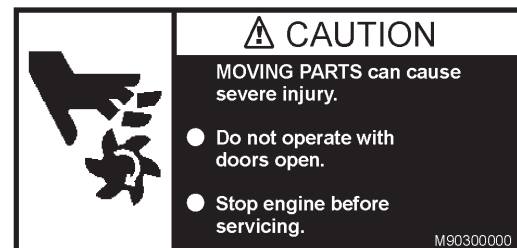

P/N M9503000004

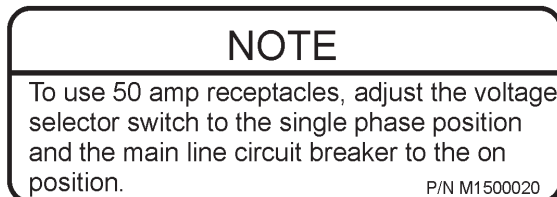

P/N M1550000204

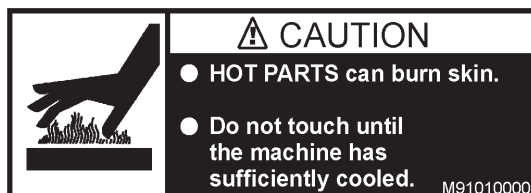

P/N M9510100004

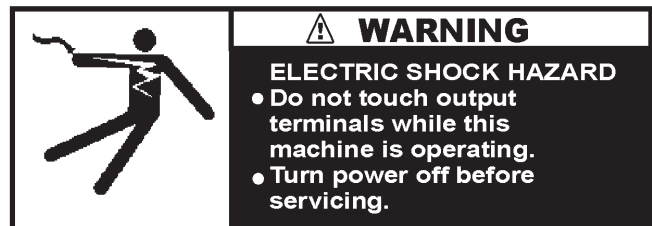

P/N M9520100503

Figure 3. Generator Decals (Continued)

## DCA-125SSJU FAMILIARIZATION

### Generator

The MQ Power Model DCA-125SSJU2 is a 100 kW **generator** (Figure 4) that is designed as a high quality portable (requires a trailer for transport) power source for telecom sites, lighting facilities, power tools, submersible pumps and other industrial and construction machinery.

### Engine Operating Panel

The "Engine Operating Panel" is provided with the following:

- Tachometer
- Water Temperature Gauge
- Oil Pressure Gauge
- Charging Ammeter Gauge
- Engine Speed Switch
- Cold Starting Button
- Panel Light
- Panel Light Switch
- Auto ON/OFF Engine Controller

### Generator Control Panel

The "Generator Control Panel" is provided with the following:

- Output Voltage Adjustment Knob
- Frequency Meter (Hz)
- AC Ammeter (Amps)
- AC Voltmeter (Volts)
- Ammeter Change-Over Switch
- Voltmeter Change-Over Switch
- Voltage Regulator
- Over-Current Relay

### Output Terminal Panel

The "Output Terminal Panel" is provided with the following:

- Three 250 VAC output receptacles (CS-6369), 50 amps
- Three auxiliary circuit breakers, 250V @ 50 amps
- Two 125 VAC output receptacles, (GFCI), 20 amps
- Two GFCI circuit breakers, 120V @ 20amps
- Five output terminal lugs (3Ø power)

### Control Box

The "Control Box" is provided with the following:

- 3-Pole, 300 amp Main Circuit Breaker
- Automatic Voltage Regulator
- Current Transformer
- Emergency Relay

### Open Delta Excitation System

The DCA-125SSJU2 generator is equipped with the state of the art "**Open-Delta**" excitation system. The open delta system consist of an electrically independent winding wound among stationary windings of the AC output section.

There are four connections of the open delta A, B, C and D. During steady state loads, the power from the voltage regulator is supplied from the parallel connections of A to B, A to D, and C to D. These three phases of the voltage input to the voltage regulator are then rectified and are the excitation current for the exciter section.

When a heavy load, such as a motor starting or a short circuit occurs, the automatic voltage regulator (AVR) switches the configuration of the open delta to the series connection of B to C. This has the effect of adding the voltages of each phase of provide higher excitation to the exciter section and thus better voltage response during the application of heavy loads.

The connections of the AVR to the AC output windings are for sensing only. No power is required from these windings.

The open-delta design provides virtually unlimited excitation current, offering maximum motor starting capabilities. The excitation does not have a "**fixed ceiling**" and responds according the demands of the required load.

### Engine

The **DCA-125SSJU2** is powered by a 4 cycle, water cooled, turbocharged **John Deere** Model 6068TF250 **diesel** engine. This engine is designed to meet every performance requirement for the generator. Reference Table 1 for engine specifications.

In keeping with MQ Power's policy of constantly improving its products, the specifications quoted herein are subject to change without prior notice.

### Mechanical Governor System

The mechanical governor system control the RPM of the engine. When the engine demands increase or decrease, the mechanical governor system regulates the frequency variation to  $\pm 5\%$ . The electronic governor option increases frequency variation to  $\pm 0.25\%$ .

### Extension Cables

When electric power is to be provided to various tools or loads at some distance from the generator, extension cords are normally used. Cables should be sized to allow for distance in length and amperage so that the voltage drop between the generator and point of use (load) is held to a minimum. Use the cable selection chart (Table 4) as a guide for selecting proper extension cable size.

# DCA-125SSJU2 —MAJOR COMPONENTS

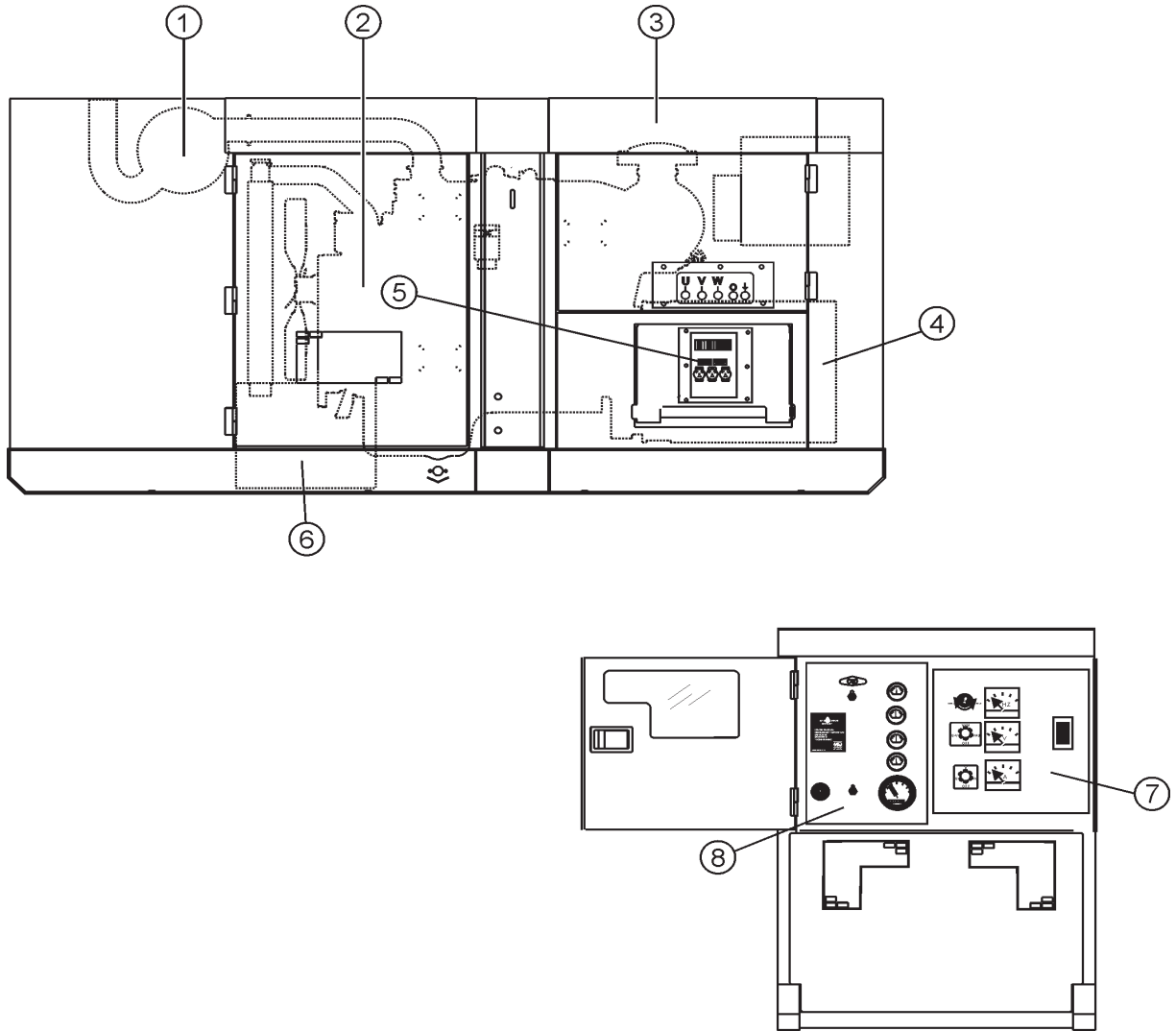
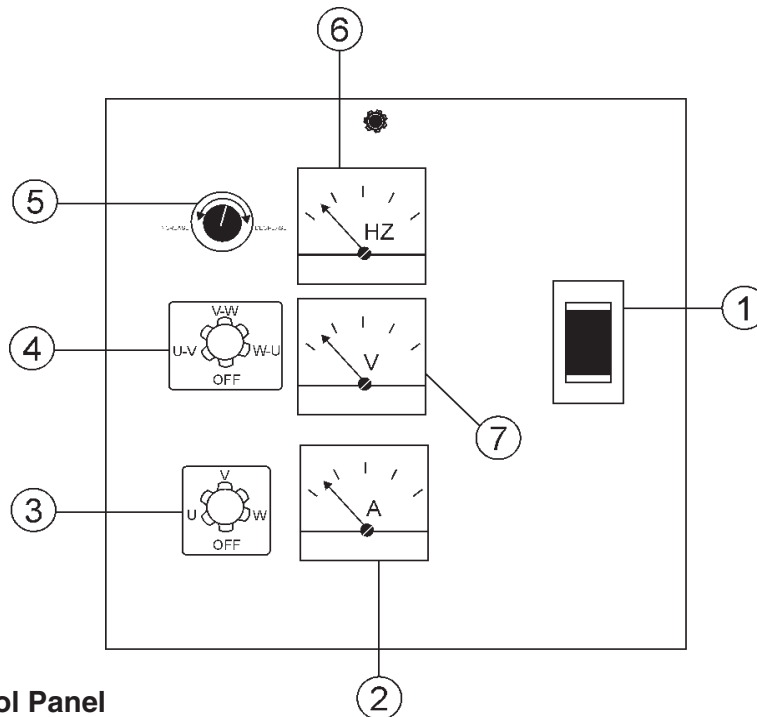

Figure 4. Major Components

Table 2. Generator Major Components	
ITEM NO.	DESCRIPTION
1	Muffler Assembly
2	Engine Assembly
3	Enclosure Assembly
4	Generator Assembly
5	Output Terminal Assembly
6	Battery Assembly
7	Generator Control Panel Assembly
8	Engine Operating Panel Assembly

# DCA-125SSJU2 — GENERATOR CONTROL PANEL



**Figure 5. Generator Control Panel**

The definitions below describe the controls and functions of the DCA-125SSJU2 "**Generator Control Panel**" (Figure 5).

1. **Main Circuit Breaker** – This three-pole, 300 amp main breaker is provided to protect the **UVWO** output terminals from overload.
2. **AC Ammeter** – Indicates the amount of current the load is drawing from the generator per leg selected by the ammeter phase-selector switch.
3. **Ammeter Change-Over Switch** – This switch allows the AC ammeter to indicate the current flowing to the load connected to any phase of the output terminals, or to be switched off. This switch does not effect the generator output in any fashion, it is for current reading only.
4. **Voltmeter Change-Over Switch** – This switch allows the AC voltmeter to indicate phase to phase voltage between any two phases of the output terminals or to be switched off.
5. **Voltage Regulator Control** – Allows  $\pm 15\%$  manual adjustment of the generator's output voltage.
6. **Frequency Meter** – Indicates the output frequency in hertz (Hz). Normally 60 Hz  $\pm 1$  Hz .
7. **AC Voltmeter** – Indicates the output voltage present at the **UVWO** terminals.

Located behind the generator control panel is the **Generator Control Box**. This box contains some of the necessary electronic components required to make the generator function.

The "**Control Box**" is equipped with the following major components:

- Over-Current Relay
- Voltage Rectifier
- Starter Relay
- Engine Controller (Computer Controlled)
- Current Transformer
- Voltage Selector Switch

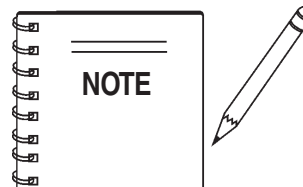

Remember the **overcurrent relay** monitors the current flowing from the **UVWO** output terminals to the load.

In the event of a short circuit or over current condition, it will automatically trip the main 300 amp breaker.

To restore power to the **UVWO** output terminals, press the **reset** button on the overcurrent relay and place the **main** circuit breaker in the **closed** position (**ON**).



# DCA-125SSJU2 — ENGINE OPERATING PANEL

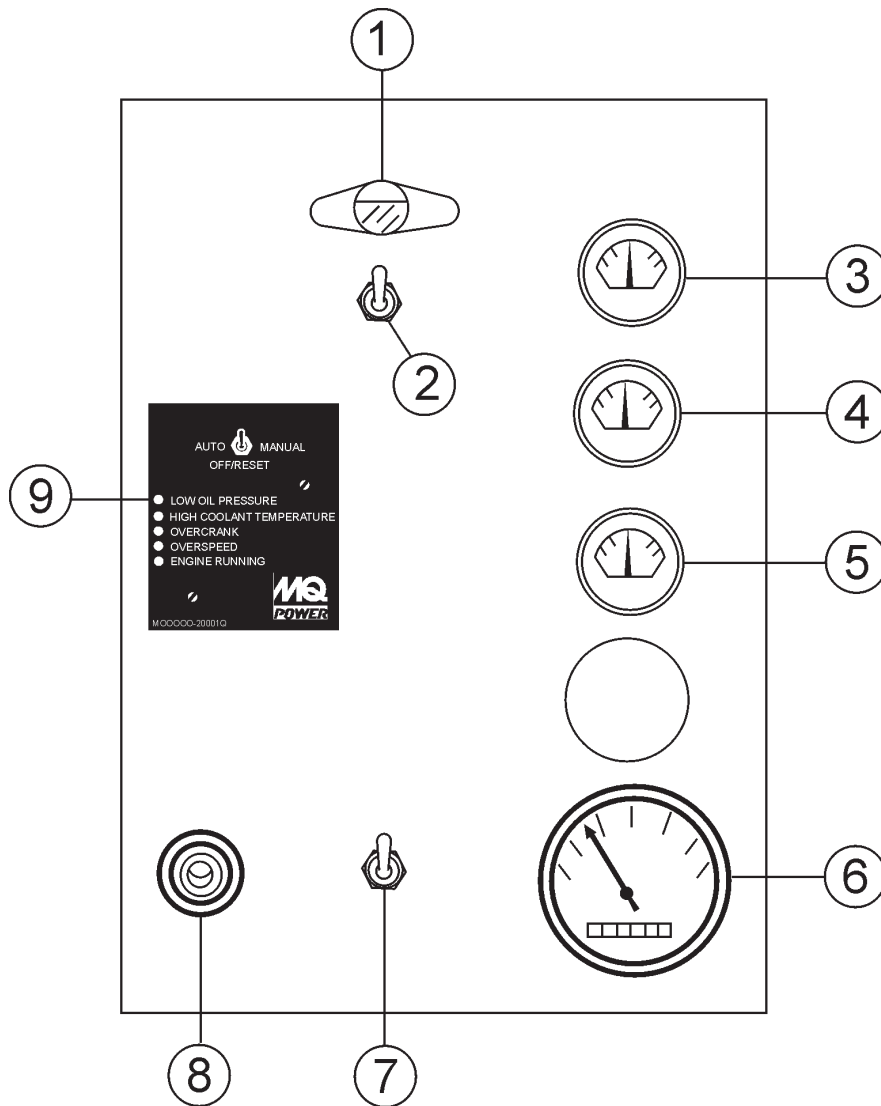

Figure 6. Engine Operating Panel From S/N 7500508

# DCA-125SSJU2 — ENGINE OPERATING PANEL

The definitions below describe the controls and functions of the DCA-125SSJU2 "**Engine Operating Panel**" (Figure 6).

1. **Panel Light** – Normally used in dark areas or at night time. When activated, panel lights will illuminate. When the generator is not in use be sure to turn the panel light switch to the **OFF** position.
2. **Panel Light Switch** – When activated will turn on control panel light.
3. **Oil Pressure Gauge** – During normal operation this gauge be should read between 42 to 71 psi. When starting the generator the oil pressure mar read a little bit higher, but after the engine warms up the oil pressure should return to the green zone.
4. **Water Temperature Gauge** – During normal operation this gauge be should read between 165° and 203°F.
5. **Charging Ammeter Gauge** – Indicates the current being supplied by the engine's alternator which provides current for generator's control circuits and battery charging system.
6. **Tachometer** – Indicates engine speed in RPM's for 60 Hz operation. This meter should indicate 1800 RPM's when the rated load is applied. In addition a built in hour meter will record the number of operational hours that the generator has been in use.
7. **Engine Speed Switch** - This switch controls the speed of the engine (low or high).
8. **Cold Starting Button** – Used to warm the engine glow plugs in cold weather conditions. Press and hold the engine cold starting button until the button illuminates.



9. **Auto On/Off Engine Controller** – This controller has a vertical row of status LED's (inset), that when lit, indicate that an engine malfunction (fault), has been detected. When a fault has been detected the engine controller will evaluate the fault. Any **major** fault will cause the controller to shutdown the generator.



During **cranking cycle**, The MPEC will attempt to crank the engine for 10 seconds before disengaging. If the engine does not engage (start) by the third attempt, the engine will be shutdown by the engine controller's "**Over Crank Protection**" mode. If the engine engages at a speed (RPM's) that is not safe, the controller will shutdown the engine by initializing the "**Over Speed Protection**" mode.

Also the engine controller will shutdown the generator in the event of low oil pressure, high coolant temperature, low coolant level, and loss of magnetic pickup. These conditions can be observed by monitoring the **LED** status indicators on the front of the controller module.

- A. **Off/Manual/Auto Switch** – This switch controls the running of the generator. If this switch is left in the "**OFF**" position, the generator will not run. When this switch is set to the **manual** position, the generator will start immediately.

If the generator is to be connected to a building's AC power source via a transfer switch (isolation), place the switch in the **auto** position. In this position the generator will monitor the AC line output from the building's power source.

- B. **Low Oil Pressure** – Indicates the engine pressure has fallen below 15 psi. The oil pressure is detected using variable resistive values from the oil pressure sending unit. This is considered a **major** fault.
- C. **High Coolant Temperature** – Indicates the engine temperature has exceeded 215° F. The engine temperature is detected using variable resistive values from the temperature sending unit. This is considered a **major** fault.
- D. **Overcrank Shutdown** – Indicates the unit has attempted to start a pre-programmed number of times, and has failed to start. The number of cycles and duration are programmable. It is pre-set at 3 cycles with a 10 second duration. This is considered a **major** fault.
- E. **Overspeed Shutdown** – Indicates the engine is running at an unsafe speed. This is considered a **major** fault.
- F. **Engine Running** – Indicates that engine is running at a safe operating speed.

# DCA-125SSJU2 — OUTPUT TERMINAL PANEL FAMILIARIZATION

## Output Terminal Familiarization

The “**Output Terminal Panel**” (Figure 7) is provided with the following:

- Three (3) 240V Output Receptacles, 50 amp
- Three (3) Circuit Breakers 240V @50 amps
- Two (2) 120V GFCI receptacles, 20 amp
- Two (2) GFCI Circuit Breakers 120V@ 20 amps
- One 300 Amp Main Circuit Breaker
- Five (5) Output Terminal Lugs

## Output Terminal Panel

The **Output Terminal Panel** ( Figure 7) shown below is located on the right-hand side (left from control panel) of the generator. Lift up on the cover to gain access to receptacles and terminal lugs.

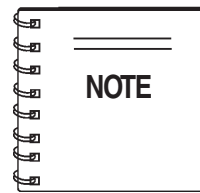

Terminal legs “O” and “Ground” are considered **bonded grounds**.

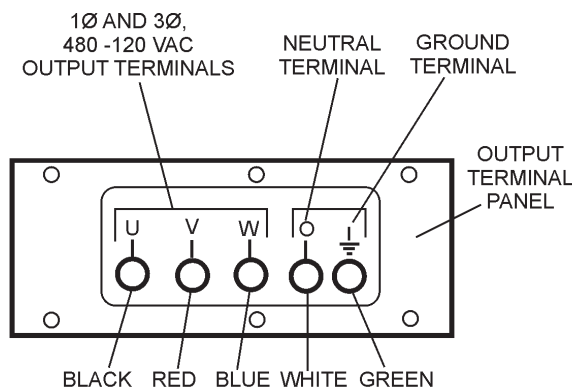
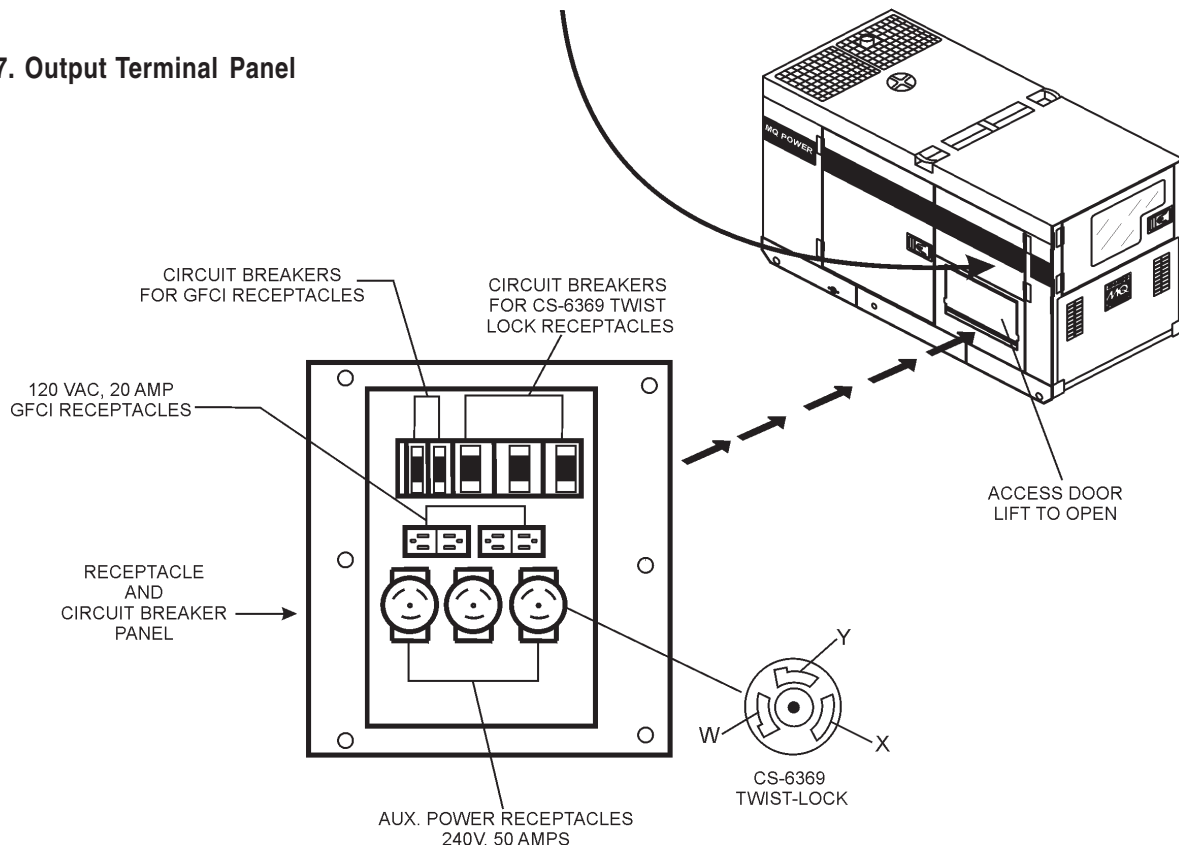

Figure 7. Output Terminal Panel



# DCA-125SSJU2 — OUTPUT TERMINAL PANEL FAMILIARIZATION

## 120 VAC GFCI Receptacles

There are two 120 VAC, 20 amp GFCI (Duplex Nema 5-20R) receptacles provided on the output terminal panel. These receptacles can be accessed in **any voltage selector switch** position. Each receptacle is protected by a 20 amp circuit breaker. These breakers are located directly above the GFCI receptacles. Remember the load output (current) of both GFCI receptacles is dependent on the load requirements of the UVWO terminals.

Pressing the **reset** button resets the GFCI receptacle after being tripped. Pressing the "**Test Button**" (See Figure 8) in the center of the receptacle will check the GFCI function. Both receptacles should be tested at least once a month.

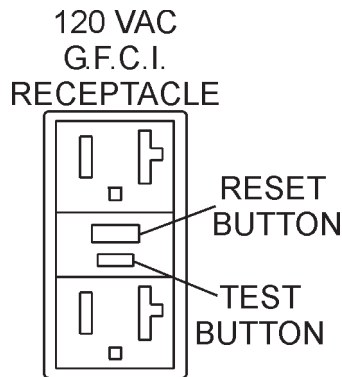

Figure 8. G.F.C.I. Receptacle

## Twist Lock Dual Voltage 120/240 VAC Receptacles

There are three 240 VAC, 50 amp auxiliary twist-lock (CS-6369) receptacles (Figure 9) provided on the output terminal panel. These receptacles can **only** be accessed when the voltage selector switch is placed in the **single-phase 240/120 position**.

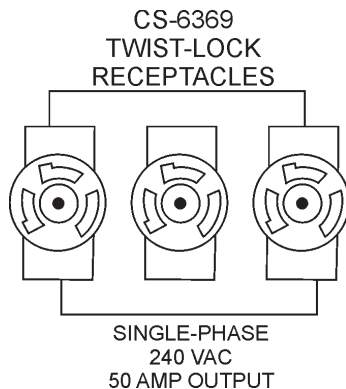

Figure 9. 240 VAC Twist-Lock Auxiliary Receptacles

Each auxiliary receptacle is protected by a 50 amp circuit breaker. These breakers are located directly above the GFCI receptacles. Remember the load output (current) on all three receptacles is dependent on the load requirements of the UVWO terminals.

Turn the **voltage regulator control knob** (Figure 10) on the control panel to obtain the desired voltage. Turning the knob clockwise will **increase** the voltage, turning the knob counter-clockwise will **decrease** the voltage.



Figure 10. Voltage Regulator Control Knob

## Removing the Plastic Face Plate (UVWO Terminals)

The UVWO terminal lugs are protected by a plastic face plate cover (Figure 11). Un-lock the locking latch, and lift the terminal cover to gain access to the plastic face plate. Remove the screws securing the face plate to the terminal enclosure, then lift the plastic hinged face plate.

After the load wires have been securely attached to the UVWO terminals, reinstall the plastic face plate. Place the terminal cover in the down position and secure the locking latch.

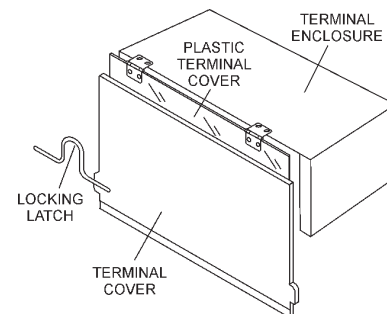

Figure 11. Plastic Face Plate (UVWO Terminals)

# DCA-125SSJU2 — OUTPUT TERMINAL PANEL FAMILIARIZATION

## Connecting Loads

Loads can be connected to the generator by the **UVWO** terminal lugs or the convenience receptacles. (See Figure 12). Make sure to read the operation manual before attempting to connect a load to the generator.

To protect the UVWO output terminals from overload, a 3-pole, 300 amp, **main** circuit breaker is provided. Make sure to switch **ALL** circuit breakers to the "OFF" position prior to starting the engine.

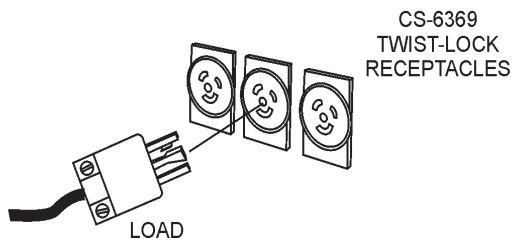
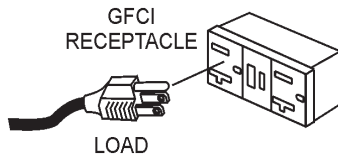
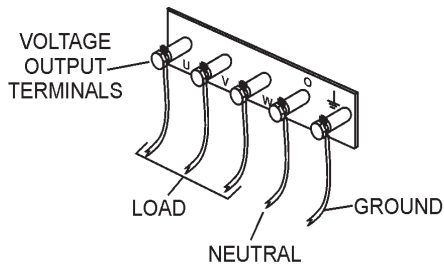

Figure 12. Connecting Loads

## Over Current Relay

An **over current relay** (Figure 13) is connected to the main circuit breaker. In the event of an overload, both the circuit breaker and the over current relay may trip. If the circuit breaker can not be reset, the **reset button** on the over current relay must be pressed. The over current relay is located in the control box.

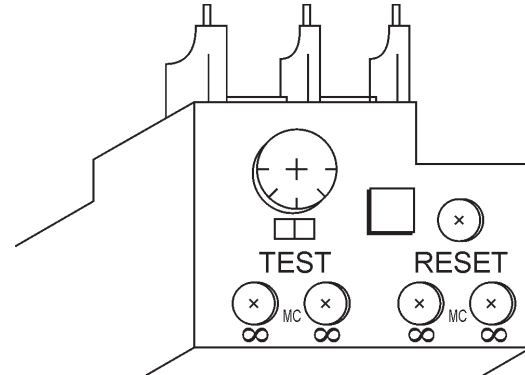

Figure 13. Over Current Relay

## Maximum Output

The entire load connected to the UVWO terminal lugs, duplex and auxiliary receptacles must not exceed 110 kw in standby or 100 kw in prime output.

## Single Phase Load

Always be sure to check the nameplate on the generator and equipment to insure the wattage, amperage and frequency requirements are satisfactorily supplied by the generator for operating the equipment.

Generally, the wattage listed on the nameplate of the equipment is its rated output. Equipment may require 130—150% more wattage than the rating on the nameplate, as the wattage is influenced by the efficiency, power factor and starting system of the equipment.



If wattage is not given on the equipment's name plate, approximate wattage may be determined by multiplying nameplate voltage by the nameplate amperage.

$$\text{WATTS} = \text{VOLTAGE} \times \text{AMPERAGE}$$

The power factor of this generator is 0.8. See Table 3 below when connecting loads.

**Table 3. Power Factor By Load**

Type Of Load	Power Factor
Single-phase induction motors	0.4 - 0.75
Electric heaters, incandescent lamps	1.0
Fluorescent lamps, mercury lamps	0.4 - 0.9
Electronic devices, communication equipment	1.0
Common power tools	0.8

**Table 4. Cable Selection (60 Hz, Single Phase Operation)**

Current in Amperes	Load In Watts		Maximum Allowable Cable Length			
	At 120 Volts	At 240 Volts	#10 Wire	#12 Wire	#14 Wire	#16 Wire
2.5	300	600	1000 ft.	600 ft.	375 ft.	250 ft.
5	600	1200	500 ft.	300 ft.	200 ft.	125 ft.
7.5	900	1800	350 ft.	200 ft.	125 ft.	100 ft.
10	1200	2400	250 ft.	150 ft.	100 ft.	
15	1800	3600	150 ft.	100 ft.	65 ft.	
20	2400	4800	125 ft.	75 ft.	50 ft.	

CAUTION: Equipment damage can result from low voltage.

## Three Phase Load

When calculating the power requirements for 3-phase power use the following equation:

$$\text{KVA} = \frac{\text{VOLTAGE} \times \text{AMPERAGE} \times 1.732}{1000}$$



Motors and motor-driven equipment draw much greater current for starting than during operation.

An inadequate size connecting cable which cannot carry the required load can cause a voltage drop which can burn out the appliance or tool and overheat the cable. See Table 5.

- When connecting a resistance load such as an incandescent lamp or electric heater, a capacity of up to the generating set's rated output (kW) can be used.
- When connecting a fluorescent or mercury lamp, a capacity of up to the generating set's rated output (kW) multiplied by 0.6 can be used.
- When connecting an electric drill or other power tools, pay close attention to the required starting current capacity.

When connecting ordinary power tools, a capacity of up to the generating set's rated output (kW) multiplied by 0.8 can be used.

## CAUTION:



Before connecting this generator to any building's electrical system, a **licensed electrician** must install an **isolation (transfer) switch**. Serious injury or death may result without this transfer switch.

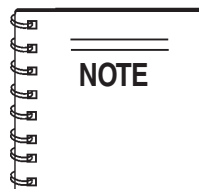

If 3Ø load (kVA) is not given on the equipment nameplate, approximate 3Ø load output may be determined by multiplying voltage by amperage by 1.732.

# DCA-125SSJU2 — GENERATOR OUTPUTS

## Generator Output Voltages

A wide range of voltages are available to supply voltage for many different applications. Voltages are selected by using the **voltage selector** switch (Figure 14). To obtain some of the voltages as listed in Table 5 (see below) will require a fine adjustment using the **voltage regulator (VR) control knob** located on the control panel.

## Voltage Selector Switch

The **voltage selector** switch (Figure 14) is located above the UVWO Hard Wire Hook-up Panel. It has been provided for ease of voltage selection.

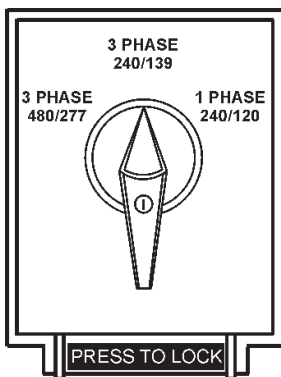

Figure 14. Voltage Selector Switch

## Voltage Selector Switch Locking Button

The voltage selector switch has a locking button to protect the generator and load from being switched while the engine is running. To lock the voltage selector switch, **press** and **hold** the **red button** located at the bottom of the switch.

## CAUTION:



**NEVER** change the position of the **voltage selector switch** while the engine is running. **ALWAYS** place circuit breaker in the open position before selecting voltage.

## Generator Amperage

Tables 6 and 7 describe the generator's current output capability for both 1Ø-phase and 3Ø phase applications.

Table 6. Generator Ampere Ratings — 1Ø

kW	240V	120V
20	83	166
25	104	208
30	225	250
35	145	291
40	166	333
45	187	375
50	208	417
60 (Max)	250	500

Table 7. Generator Ampere Ratings — 3Ø

kW	208V	240V	480V
20	59	60	30
25	87	75	38
30	104	90	45
35	121	105	53
40	139	120	60
45	156	136	68
50	174	152	76
60	208	181	99

Table 5. Voltages Available

Three Phase (Switchable)	208 VOLT	220 VOLT	240 VOLT	416 VOLT	440 VOLT	480 VOLT
Single Phase (Switchable)	120 VOLT	127 VOLT	139 VOLT	240 VOLT	254 VOLT	277 VOLT

# DCA-125SSJU2 — GENERATOR OUTPUTS/GAUGE READING

## GFCI Receptacle Load Capability

The load capability of the GFCI receptacles is directly related to the voltage being supplied at either the UVWO terminals or the 3 twist lock auxilliary receptacles.

Tables 8 and 9 show what amount of current is available at the GFCI receptacles when the UVWO terminals and twist lock receptacles are in use. Be careful that your load does not to exceed the available current capability at the receptacles.

**Table 8. GFCI Receptacle Load Capability**

KVA in Use (UVWO Terminals)	Available Load Current (AMPS)
3Ø 240/480V	GFCI Duplex NEMA 5-20R 120V
82	0
77.8	5 amps per receptacle
73.7	10 amps per receptacle
69.5	15 amps per receptacle
65.4	20 amps per receptacle

**Table 9. GFCI Receptacle Load Capability**

KW in Use Twist-Lock (CS6369)	Available Load Current (AMPS)
1Ø 240/120V	GFCI Duplex NEMA 5-20R 120V
60	0
58.8	5 amps per receptacle
57.6	10 amps per receptacle
56.4	15 amps per receptacle
55.2	20 amps per receptacle

## How to Read the Output Terminal Gauge.

The gauge and selector switch on the control panel **DO NOT** effect the generator output. They are provided to help observe how much power is being supplied, produced at the UVWO terminals lugs.

When the Voltage selector switch is in the 3Ø,240/139V position (See Figure 15), place the **AC Voltmeter Change-Over Switch** (Figure 16) to the W-U position and the **AC Ammeter Change-Over Switch** (Figure 18) to the U or W position to read the output on the selected leg.

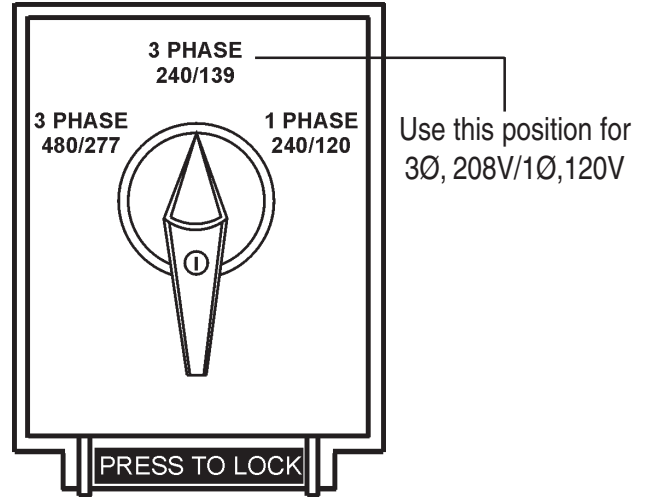

Figure 15. Voltage Selector Switch 240/139V Three Phase Position (for 3Ø, 208V, 120V voltage)

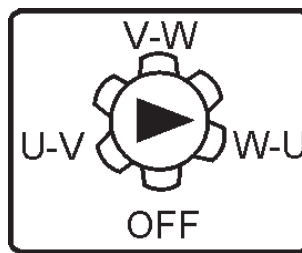

Figure 16. AC Voltmeter Change-Over Switch

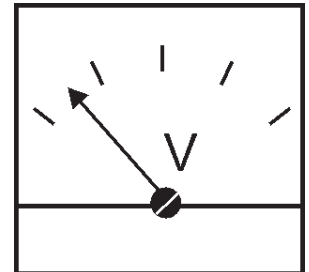

Figure 17 AC Voltmeter Gauge (Volt reading on W-U Lug)

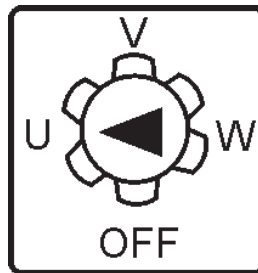

Figure 18. AC Ammeter Change-Over Switch

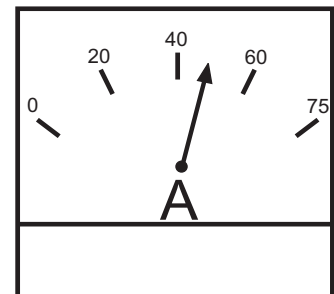
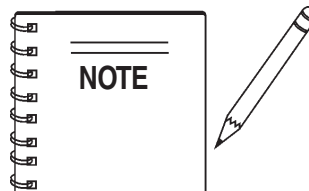

Figure 19. AC Ammeter (Amp reading on U lug)



The **ammeter** and **voltmeter** gauges are only active when the UVWO terminals are in use.

# DCA-125SSJU2 — OUTPUT TERMINAL PANEL CONNECTIONS

## UVWO Terminal Output Voltages

Various output voltages can be obtained using the UVWO output terminal lugs. The voltages at the terminals are dependent on the position of the **Voltage Selector Switch** and the adjustment of the **Voltage Regulator Control Knob**.

Remember the voltage selector switch determines the **range** of the output voltage. The voltage regulator (VR) allows the user to increase or decrease the selected voltage.

## 3Ø 240/139 UVWO Terminal Output Voltages

1. Place the voltage selector switch in the 3Ø 240/139 position as shown in Figure 20.

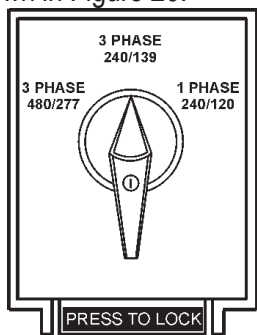

Figure 20. Voltage Selector Switch 240/139V Three-Phase Position

2. Connect the load wires to the UVWO terminals as shown in Figure 21.

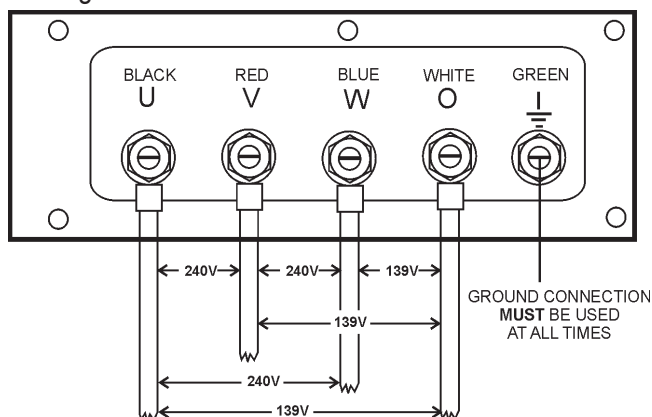

Figure 21. UVWO Terminal Lugs 240/139V Three Phase Connections

3. Turn the voltage regulator knob (Figure 22) clockwise to increase voltage output, turn counterclockwise to decrease voltage output.



Figure 22. Voltage Regulator Knob (139V/240V)

## 3Ø 208V/1Ø120V UVWO Terminal Output Voltages

1. Place the voltage selector switch in the 3Ø 240/139 position as shown in Figure 23.

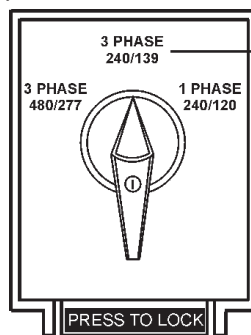

Use this position for 3Ø-208 or 1Ø120V.

Figure 23. Voltage Selector Switch 3Ø-208V/1Ø-120V Three-Phase Position

2. Connect the load wires to the UVWO terminals as shown in Figure 24.

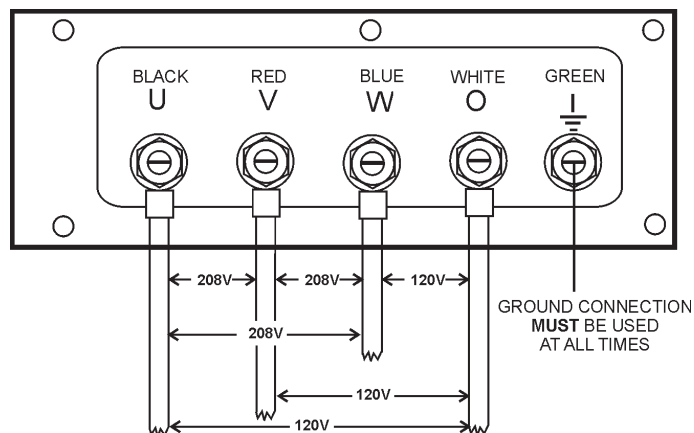
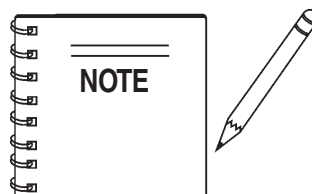

Figure 24. UVWO Terminal Lugs 3Ø-208V/120V Connections

3. Turn the voltage regulator knob (Figure 25) clockwise to increase voltage output, turn counterclockwise to decrease voltage output.



Figure 25. Voltage Regulator Knob (208V)



To achieve a 3Ø 208V output the voltage selector switch must be in the 3Ø-240/139 position and the voltage regulator must be adjusted to 208V.

# DCA-125SSJU2 — OUTPUT TERMINAL PANEL CONNECTIONS

## 3Ø 480/277 UVWO Terminal Output Voltages

1. Place the voltage selector switch in the 3Ø 480/277 position as shown in Figure 26.

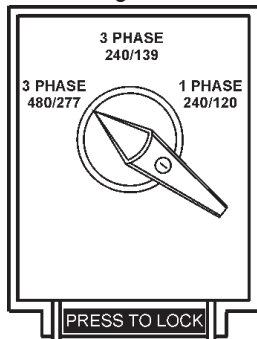

Figure 26. Voltage Selector Switch 480/277V Three-Phase Position

2. Connect the load wires to the UVWO terminals as shown in Figure 27.

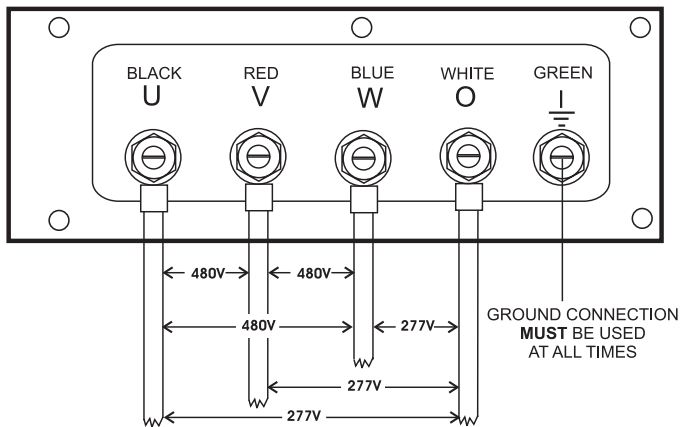

Figure 27. UVWO Terminal Lugs 240/139V Three Phase Connections

3. Turn the voltage regulator knob (Figure 28) clockwise to increase voltage output, turn counterclockwise to decrease voltage output.



Figure 28. Voltage Regulator Knob (139V/240V)

## 1Ø 240V/120V UVWO Terminal Output Voltages

1. Place the voltage selector switch in the 1Ø 240/120 position as shown in Figure 29.

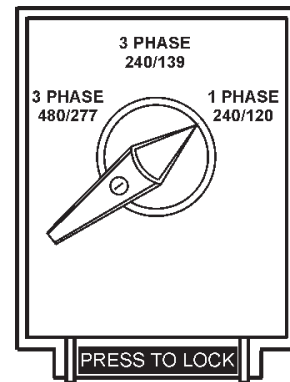

Figure 29. Voltage Selector Switch 240/120V Single-Phase Position

2. Connect the load wires to the UVWO terminals as shown in Figure 30.

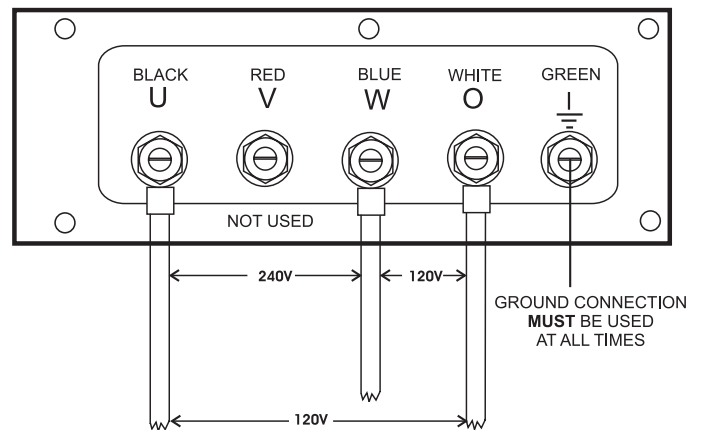

Figure 30. UVWO Terminal Lugs 1Ø-240V/120V Connections

3. Turn the voltage regulator knob (Figure 31) clockwise to increase voltage output, turn counterclockwise to decrease voltage output.



Figure 31. Voltage Regulator Knob (1Ø-240/120V)

## Circuit Breakers

To protect the generator from an overload, a 3-pole, 300 amp, **main** circuit breaker is provided to protect the UVW output terminals from overload. In addition two single-pole, 20 amp **GFCI** circuit breakers are provided to protect the GFCI receptacles from overload. Three 50 amp **load** circuit breakers have also been provided to protect the auxiliary receptacles from overload. Make sure to switch **ALL** circuit breakers to the "OFF" position prior to starting the engine.

## Lubrication Oil

Fill the engine crankcase with lubricating oil through the filler hole, but **DO NOT** overfill. Make sure the generator is level. and verify that the oil level is maintained between the two notches (Figure 32) on the dipstick. See Table 10 for proper selection of engine oil.

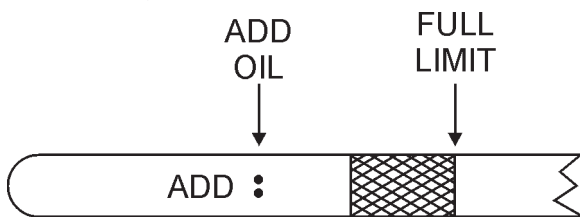

**Figure 32. Engine Oil Dipstick**

When checking the engine oil, be sure to check if the oil is clean. If the oil is not clean, drain the oil by removing the oil drain plug, and refill with the specified amount of oil as outlined in the **John Deere Engine Owner's Manual**. Oil should be warm before draining.

Other types of motor oils may be substituted if they meet the following requirements:

- API Service Classification CH-4
- API Service Classification CG-4
- API Service Classification CF-4
- ACEA Specification E3
- ACEA Specification E2

**Table 10. Recommended Motor Oil**

Temperature Range	Type Oil
77°F and greater (25°C and greater)	SAE15W-40 or SAE40
32°F to 77°F (0°C to 25°C)	SAE 10W-30 or SAE30
-22°F to -32°F (-30°C to 0°C)	SAE10W-30 or SAE10

## Fuel Check

### DANGER:

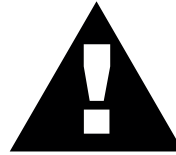

Fuel spillage on a **hot!** engine can cause a **fire** or **explosion**. If fuel spillage occurs, wipe up the spilled fuel completely to prevent fire hazards. **NEVER!** smoke around or near the generator.



## Refilling the Fuel System

The **DCA125SSJU2 (FEMA)** is equipped with a **skid mounted** fuel tank (Figure 33). The skid type fuel system **does not use** the internal generator fuel tank.

**ALWAYS** fill the fuel tank with clean and fresh **#2 diesel fuel**. **DO NOT** fill the fuel tanks beyond their capacities.

Pay attention to the fuel tank capacity when replenishing fuel. The fuel tank cap must be closed tightly after filling. Handle fuel in a safety container. If the container does not have a spout, use a funnel. Wipe up any spilled fuel immediately.

### WARNING:



**ONLY properly trained personel** who have read and understand this section should refill the double fuel tank system. Use **#2 diesel fuel**.

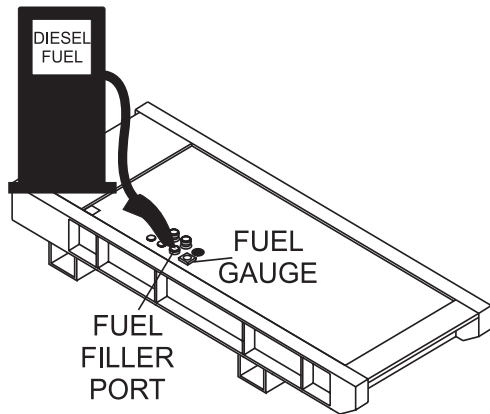

Figure 33. Skid Type Fuel Tank System

Refueling Procedure:

**DANGER:**



*Diesel fuel* and its vapors are dangerous to your health and the surrounding environment. Avoid skin contact and/or inhaling fumes.



1. **Level Tanks** – make sure fuel cells are level with the ground. Failure to do so will cause fuel to spill from the tank before reaching full capacity.

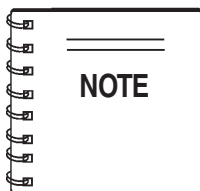

**ONLY!** use **#2 diesel fuel** when refueling.

**WARNING:**



**DO NOT OVER-FILL** fuel system. Leave room for fuel expansion. Fuel expands when heated.

## Coolant (Ethylene Glycol [Green] / Water — 50/50 mix)

Use only drinkable tap water. If hard water or water with many impurities is used, the inside of the engine and radiator may become coated with deposits and cooling efficiency will be reduced.

An anticorrosion additive added to the water will help prevent deposits and corrosion in the cooling system. See the engine manual for further details.

## CAUTION:



If adding coolant/antifreeze mix to the radiator, **DO NOT** remove the radiator cap until the unit has completely cooled. The possibility of **hot!** coolant exists which can cause severe burns.



Day-to-day addition of coolant is done from the recovery tank. When adding coolant to the radiator, **DO NOT** remove the radiator cap until the unit has completely cooled. See Table 11 for engine, radiator, and recovery tank coolant capacities. Make sure the coolant level in the recovery tank is always between the "H" and the "L" markings.

**Table 11. Coolant Capacity**

Engine and Radiator	6.9 Gal. (26 Liters)
Reserve Tank	2 Quarts (1.9 Liters)

## Operation Freezing Weather

When operating in freezing weather, be certain the proper amount of antifreeze (Table 12) has been added.

**Table 12. Anti-Freeze Operating Temperatures**

Vol % Anti-Freeze	Freezing Point		Boiling Point	
	°C	°F	°C	°F
40	-24	-12	106	222
50	-37	-34	108	226

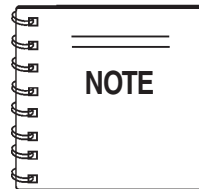

When the antifreeze is mixed with water, the antifreeze mixing ratio **must be** less than 50%.

## Cleaning the Radiator

The engine may overheat if the radiator fins become overloaded with dust or debris. Periodically clean the radiator fins with compressed air. Cleaning inside the machine is dangerous, so clean only with the engine turned off and the **negative** battery terminal disconnected.

## Air Cleaner

Periodic cleaning/replacement is necessary. Inspect it in accordance with the **John Deere Engine Owner's Manual**.

## Fan Belt Tension

A slack fan belt may contribute to overheating, or to insufficient charging of the battery. Inspect the fan belt for damage and wear and adjust it in accordance with the **John Deere Engine Owner's Manual**.

The fan belt tension is proper if the fan belt bends 10 to 15 mm (Figure 34) when depressed with the thumb as shown below.

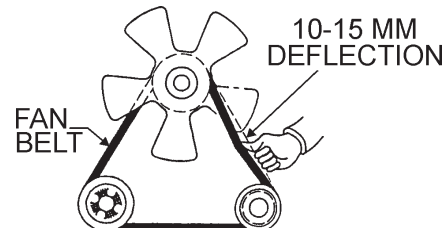

**Figure 34. Fan Belt Tension**

## CAUTION:



**NEVER!** place hands near the belts or fan while the generator set is running.



## Battery

This unit is of negative ground **DO NOT** connect in reverse. Always maintain battery fluid level between the specified marks. Battery life will be shortened, if the fluid level are not properly maintained. Add only distilled water when replenishment is necessary.

**DO NOT** over fill. Check to see whether the battery cables are loose. Poor contact may result in poor starting or malfunctions. **Always** keep the terminals firmly tightened. Coating the terminals with an approved battery terminal treatment compound. Replace battery with only recommended type battery. The battery type used in this generator is BCI Group 27.

The battery is sufficiently charged if the specific gravity of the battery fluid is 1.28 (at 68° F). If the specific gravity should fall to 1.245 or lower, it indicates that the battery is dead and needs to be recharged or replaced.

## Battery Cable Installation

**ALWAYS** be sure the battery cables (Figure 35) are properly connected to the battery terminals as shown below. The **RED** cable is connected to the positive terminal of the battery, and the **BLACK** cable is connected to the negative terminal of the battery.

## CAUTION:



**ALWAYS** disconnect the negative terminal **FIRST** and reconnect negative terminal **LAST**.

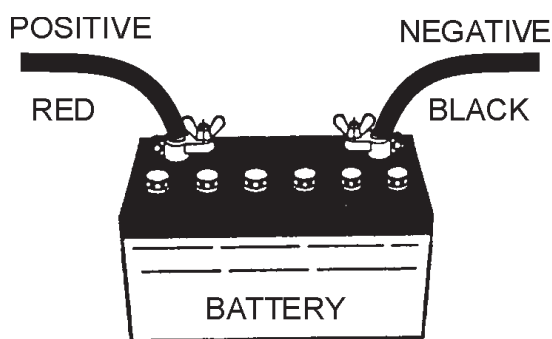
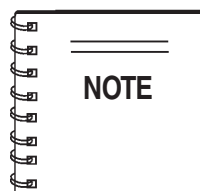

Figure 35. Battery Connections

When connecting battery do the following:

1. **NEVER** connect the battery cables to the battery terminals when the **ignition** switch is in either the **Pre-Heat, RUN, or START** position. **ALWAYS** make sure that the ignition switch is in the **STOP** position when connecting the battery.
2. Place a small amount of battery terminal treatment compound around both battery terminals. This will ensure a good connection and will help prevent corrosion around the battery terminals.



If the battery cable is connected incorrectly, electrical damage to the generator will occur. Pay close attention to the polarity of the battery when connecting the battery.

## CAUTION:



Inadequate battery connections may cause poor starting of the generator, and create other malfunctions.

## Alternator

The polarity of the alternator is negative grounding type. When an inverted circuit connection takes place, the circuit will be in short circuit instantaneously resulting the alternator failure.

**DO NOT** put water directly on the alternator. Entry of water into the alternator leads an electrolyte corrosion causing an alternator failure.

Before charging the battery with an external electric source, be sure to disconnect the battery cables.

## Wiring

Inspect the entire generator for bad or worn electrical wiring or connections. If any wiring or connections are exposed (insulation missing) replace wiring immediately.

## Piping and Hose Connection

Inspect all piping, oil hose, and fuel hose connections for wear and tightness. Tighten all hose clamps and check hoses for leaks.

If any hose (**fuel** or **oil**) lines are defective replace them immediately.

# DCA-125SSJU2 — GENERATOR START-UP PROCEDURE (MANUAL)

## WARNING:



The engine's exhaust contains harmful emissions. **ALWAYS have adequate ventilation when operating.** Direct exhaust away from nearby personnel.

## BEFORE STARTING

### Generator and Control Panel

## CAUTION:



**NEVER!** manually start the engine with the **main, GFCI** or **auxiliary** circuit breakers in the **ON** (closed) position.

1. Be sure and place the **main, G.F.C.I.** and **aux.** circuit breakers (Figure 36) in the “**OFF**” position prior to starting the engine.

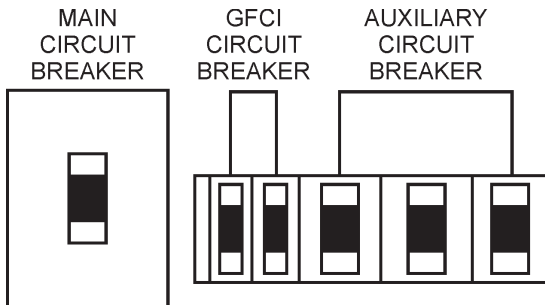

**Figure 36. Main, Aux. and GFCI Circuit Breakers**

2. Connect the load to the **UVWO** terminals or **auxiliary receptacles** as shown in Figure 37. These load connection points can be found on the output terminal panel. To gain access to the UVWO terminals or other power receptacles, unlock the access cover and lift the door.

The UVWO terminals are protected by a plastic cover, remove this cover to gain access to the terminals. Tighten terminal nuts securely to prevent load wires from slipping out.

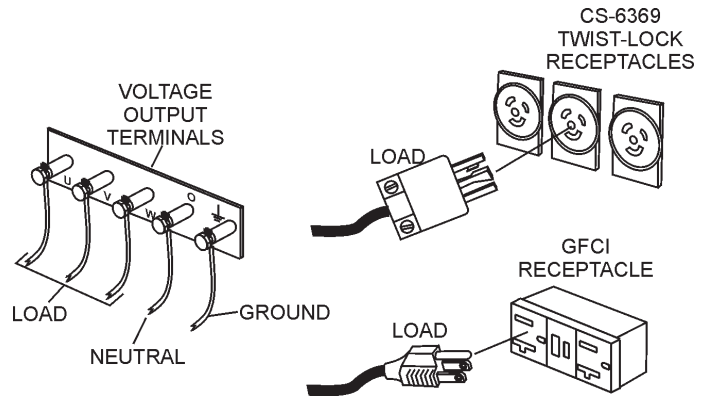

**Figure 37. Load Connections**

3. Close all engine enclosure doors (Figure 38).

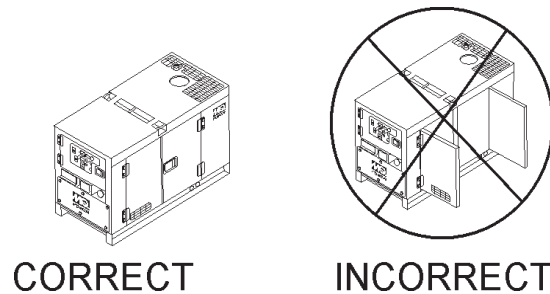

**Figure 38. Engine Enclosure Doors**

4. When starting the generator in **COLD** weather conditions, press and hold the engine preheat button (Figure 39).



**Figure 39. Pre-Heat Lamp**

5. Place the voltage selector switch in the desired voltage position (Figure 40).

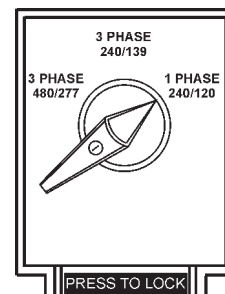

**Figure 40. Voltage Selector Switch**

# DCA-125SSJU2 — GENERATOR START-UP PROCEDURE (MANUAL)

6. Set engine speed switch to “**LOW**” (Figure 41).

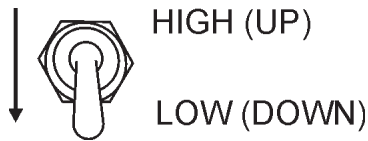

**Figure 41. Engine Speed Switch (Low)**

7. Place the Auto-Off/Reset-Manual switch in the “**MANUAL**” position to start the engine (Figure 42). Once the engine starts, let the engine run for 1-2 minutes. Listen for any abnormal noises.

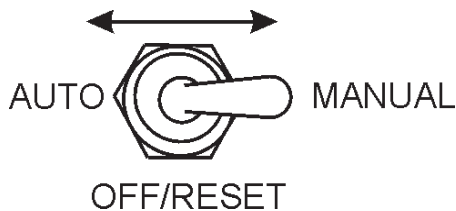

**Figure 42. Auto-Off/Reset-Manual Switch**

8. Once the engine is warm and the engine is running properly, set the engine speed switch to “**HIGH**” (Figure 43).

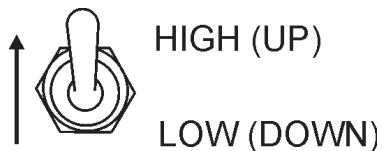

**Figure 43. Engine Speed Switch (High)**

9. Verify that the “**Engine Running**” status LED on the MPEC unit (Figure 44) is “**ON**” (lit) after the engine has been started.



**Figure 44. Engine Running LED (ON)**

9. The generator's frequency meter (Figure 45) displays the 60 cycle output frequency in **HERTZ**.

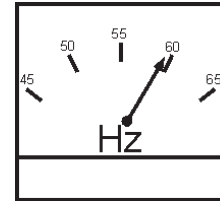

**Figure 45. Frequency Meter (Hz)**

10. The generator's voltage meter (Figure 46) displays the 120VAC in **VOLTS**. If the voltage is not within the specified frequency tolerance,

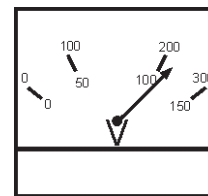

**Figure 46. Voltmeter**

11. Use the voltage adjustment control knob (Figure 47) to increase or decrease the desired voltage.



**Figure 47. Voltage Adjust Control Knob**

12. The ammeter (Figure 48) will indicate zero amps with no load applied. When a load is applied, this meter will indicate the amount of current that the load is drawing from the generator.

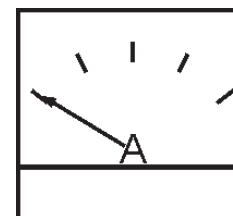

**Figure 48. Ammeter (No Load)**

# DCA-125SSJU2 — GENERATOR START-UP PROCEDURE (MANUAL)

14. The engine oil pressure gauge (Figure 49) will indicate the oil pressure (kg/ cm<sup>2</sup>) of the engine. Under normal operating conditions the oil pressure is approximately

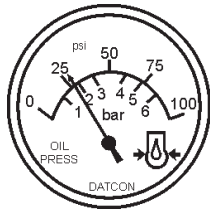

Figure 49. Oil Pressure Gauge

15. The coolant temperature gauge (Figure 50) will indicate the coolant temperature. Under normal operating conditions the coolant temperature is between 165 and 215 degrees fahrenheit.

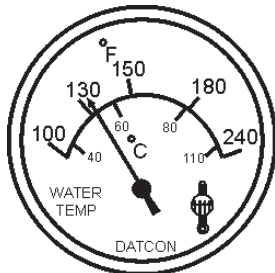

Figure 50. Coolant Temperature Gauge

16. The tachometer (Figure 51) will indicate the speed of the engine when the generator is operating. Under normal operating conditions this speed is approximately 1800 RPM's.

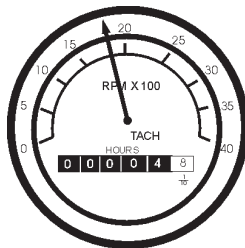

Figure 51. Engine Tachometer

17. Turn the *main*, *GFCI*, and *aux.* circuit breakers to the "ON" position (Figure 52).

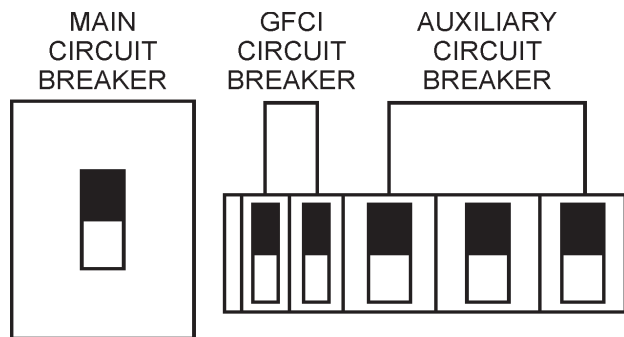

Figure 52. Main, AUX. and GFCI Circuit Breakers (ON)

18. Observe the generator's ammeter (Figure 53) and verify it reads the anticipated amount of current with respect to the load. The ammeter will only display a current reading if the load is in use.

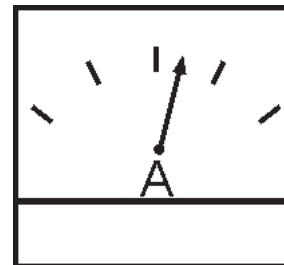

Figure 53. Ammeter (Load)

19. The generator will run until manually stopped or an abnormal condition occurs.

# DCA-125SSJU2 — GENERATOR START-UP PROCEDURE (AUTO MODE)

## DANGER:



Before connecting this generator to any building's electrical system, a **licensed electrician** must install an **isolation** (transfer)



**switch**. Serious **injury** or **death** may result without this transfer switch.

## CAUTION:



When connecting the generator to a isolation (transfer) switch, **ALWAYS** have power applied to the generator's internal battery charger. This will ensure that the engine will not fail due to a dead battery.

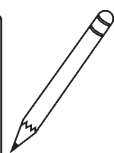
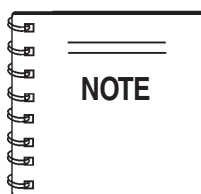

When the generator is set in the "AUTO" mode, the generator will **automatically start** in the event of commercial power falling below a prescribed level by means of a contact closure that is generated automatically by a transfer switch.

## WARNING:



When running the generator in the "AUTO" mode, remember the generator can start up at any time without warning. **NEVER** attempt to perform any maintenance when the generator is in the auto mode.

28. Perform steps 1 through 5 in the **Before Starting** section (pages 36) as outlined in the **Manual Starting Procedure**.

29. Set the engine speed switch (Figure 54) to the "HIGH" position.

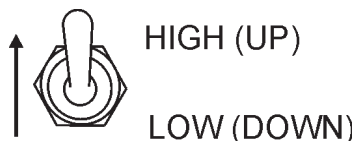

Figure 54. Engine Speed Switch (High)

## CAUTION:



The **Engine Speed Switch** **must** be set to the "HIGH" position when running in the **Auto-Start** mode. Failing to set the switch in the proper position can result in damage to your generator when it turns on.

30. Place the Off/Manual/Auto switch (Figure 55) in the "AUTO" position .



Figure 55. Off/Manual Auto Switch (AUTO)

31. Continue to follow the steps outlined in the "Manual Start-up" procedure (start at step 9, page 37).

# DCA-125SSJU2 — GENERATOR SHUT-DOWN PROCEDURE

## Shutdown Procedure

To shutdown the generator use the following procedure:

1. Place both the **MAIN**, **GFCI** and **LOAD** circuit breakers as shown in Figure 36 to the "OFF" position.
2. Place the engine speed switch in the "LOW" position (Figure 56).



**Figure 56. Engine Speed Switch (Low)**

3. Let the engine cool by running it for 3-5 minutes with no load applied.
4. Place the Auto-Off/Reset-Manual switch (Figure 57) to the "OFF/RESET" position.



**Figure 57. Off/Manual Auto Switch (Off)**

5. Verify that the **all** status LED on the MPEC display (Figure 44) are "OFF" (not lit).
6. Remove all loads from the generator.

## Emergency Shutdown Procedure

1. To shut-down the engine in the event of an emergency, switch the **MAIN**, **GFCI** and **LOAD** (Figure 36) circuit breakers to "OFF" position.
2. Place the Auto-Off/Reset-Manual switch (Figure 57) to the "OFF/RESET" position.

## CAUTION:



**NEVER** stop the engine suddenly except in an emergency. **DO NOT** use the emergency stop switch as a method of shutting down the generator. This switch is **ONLY** to be used in the event of an emergency.

TABLE 13. INSPECTION / MAINTENANCE		10 Hrs DAILY	250 Hrs	500 Hrs	1000 Hrs
<b>ENGINE</b>	Check Engine Fluid Levels	X			
	Check Fuel Filter/Water Separator	X			
	Check Air Cleaner Dust Unloader	X			
	Check for Leaks/Visual Walk Around	X			
	Check for Loosening of Parts	X			
	Replace Engine Oil and Filter *1		X		
	Service Battery		X		
	Clean Unit, Inside and Outside		X		
	Change Fuel Filter *2			X	
	Clean Radiator and Check Coolant Protection Level			X	
	Replace Air Filter Element				X
	Test Thermostats				X
	Check all Hoses and Clamps/Flush Radiator				X
	Clean Inside of Fuel Tank				X
<b>GENERATOR</b>	Measure Insulation Resistance Over 3M ohms		X		

\*1 Replace engine oil and filter at 100 hours, first time only.

\*2 Replace fuel filter at 250 Hours, first time only.

### General Inspection

Prior to each use, the generator should be cleaned and inspected for deficiencies. Check for loose, missing or damaged nuts, bolts or other fasteners. Also check for fuel, oil, and coolant leaks.

### Engine Side (Refer to the Engine Instruction Manual)

#### Air Cleaner

Every 50 hours: Remove air cleaner element and clean the heavy duty paper element with kerosene, or foam element with liquid detergent and hot water. Wrap foam element in a cloth and squeeze dry. For heavy duty paper element, wipe excess kerosene with towel.

#### Air Cleaner with Dust Indicator

This indicator is attached to the air cleaner. When the air cleaner element is clogged, air intake restriction becomes greater and the dust indicator signal shows “**RED**” meaning the element needs changing. After changing the air element, press the dust indicator button to reset the indicator.

### Service Daily

If the engine is operating in very **dusty** or **dry grass** conditions, a clogged air cleaner will result. This can lead to a loss of power, excessive carbon buildup in the combustion chamber and high fuel consumption. Change air cleaner more **frequently** if these conditions exist.

### Fuel Addition

Add diesel fuel (the grade may vary according to season and locations). Always pour through the mesh filter.

### Removing Water from the Fuel Tank

After prolonged use, water and other impurities accumulate in the bottom of the tank. Occasionally remove the drain cock and drain the contents. During cold weather, the more empty volume inside the tank, the easier it is for water to condense. This can be reduced by keeping the tank full with diesel fuel.

## Air Removal

If air enters the fuel injection system of a diesel engine, starting becomes impossible. After running out of fuel, or after disassembling the fuel system, bleed the system according to the following procedure.

To restart after running out of fuel, turn the switch to the "ON" position for 15-30 seconds. Try again, if needed. This unit is equipped with an automatic air bleeding system.

## Cleaning the Fuel Strainer

Clean the fuel strainer if it contains dust or water. Remove dust or water in the strainer cap and wash it in gasoline. Securely fasten the fuel strainer cap so that fuel will not leak. Check the fuel strainer every 200 hours of operation or once a month.

## Check Oil Level

Check the crankcase oil level prior to each use, or when the fuel tank is filled. Insufficient oil may cause severe damage to the engine. Make sure the generator is level. The oil level must be between the two notches on the dipstick as shown in Figure 31.

## Replacing Oil Filter

- Detach the oil filter by loosening center bolt and remove the element together with the filter body.
- Apply a film of oil to the gasket for the cartridge.
- Install the filter body together with the element and fix them by tightening the center bolt.
- After the oil cartridge has been replaced, the engine oil will drop slightly. Run the engine for a while and check for leaks before adding more oil if needed. Clean excessive oil from engine.

## Replacing Fuel Filter

- Replace the fuel filter cartridge with new one every 400 hours or so.
- Loosen the drain plug at the lower top of the fuel filter. Drain the fuel in the fuel body together with the mixed water. **DO NOT** spill the fuel during disassembly.
- Vent any air.

## Feed Pump Strainer Cleaning

The strainer is incorporated in the feed pump inlet side joint bolt. Clean the strainer with compressed air and rinse it in the fuel oil.

## Flushing Out Radiator and Replacing Coolant

- Open both cocks located at the crankcase side and at the lower part of the radiator and drain coolant. Open the radiator cap while draining. Remove the overflow tank and drain.
- Check hoses for softening and kinks. Check clamps for signs of leakage.
- Flush the radiator by running clean tap water through radiator until signs of rust and dirt are removed. **DO NOT** clean radiator core with any objects, such as a screwdriver.
- Tighten both cocks and replace the overflow tank.
- Replace with coolant (Table 12 for correct mixture).
- Close radiator cap tightly.

## CAUTION:

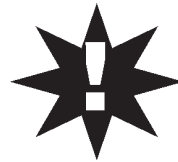

Allow engine to **cool** when flushing out radiator. Flushing the radiator while **hot!** will damage radiator.

## Generator Storage

For long term storage of the generator the following is recommended:

- Fill the fuel tank completely. Treat with a fuel stabilizer if necessary.
- Completely drain the oil from the crankcase and refill if necessary with fresh oil.
- Clean the entire generator, internal and external.
- Cover the generating set and store in a clean, dry place.
- Disconnect the battery.
- Make sure engine coolant is at proper level.
- If generator is mounted on a trailer, jack trailer up and place on block so tires do touch the ground or remove tires.

## Jacket Water Heater and Internal Battery Charger 120 VAC Input Receptacles (OPTIONAL)

This generator is equipped with two 120 VAC, 20 amp input receptacles located on the output terminal panel.

The purpose of these receptacles is to provide power via commercial power to the **jacket water heater** and **internal battery charger**.

These receptacles will **ONLY** function when commercial power has been supplied to them (Figure 58). To apply commercial power to these receptacles, a power cord of adequate size will be required (See Table 4).

When using the generator in **hot** climates there is no reason to apply power to jacket water heater. However, if the generator will be used in **cold** climates it is always a good idea to apply power to the jacket water heater at all times. To apply power to the jacket water heater simply apply power to the jacket water heater receptacle via commercial power using a power cord of adequate size.

If the generator will be used daily, the battery should normally not require charging. If the generator will be idle (not used) for long periods of time, apply power to the battery charger receptacle via commercial power using an power cord of adequate size.

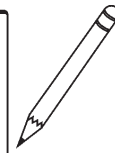
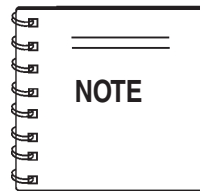

To ensure adequate starting capability, **always** have power applied to the generator's **internal battery charger**.

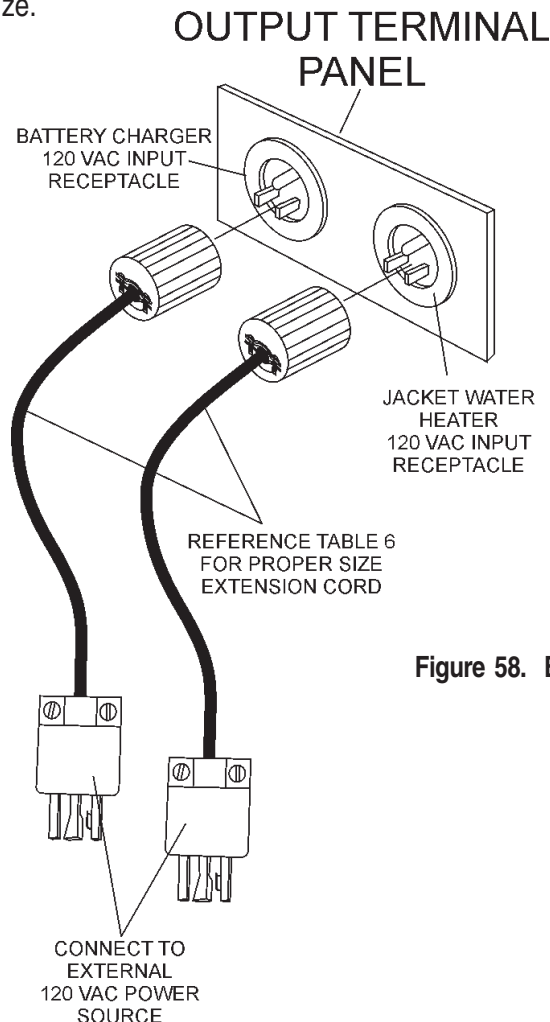
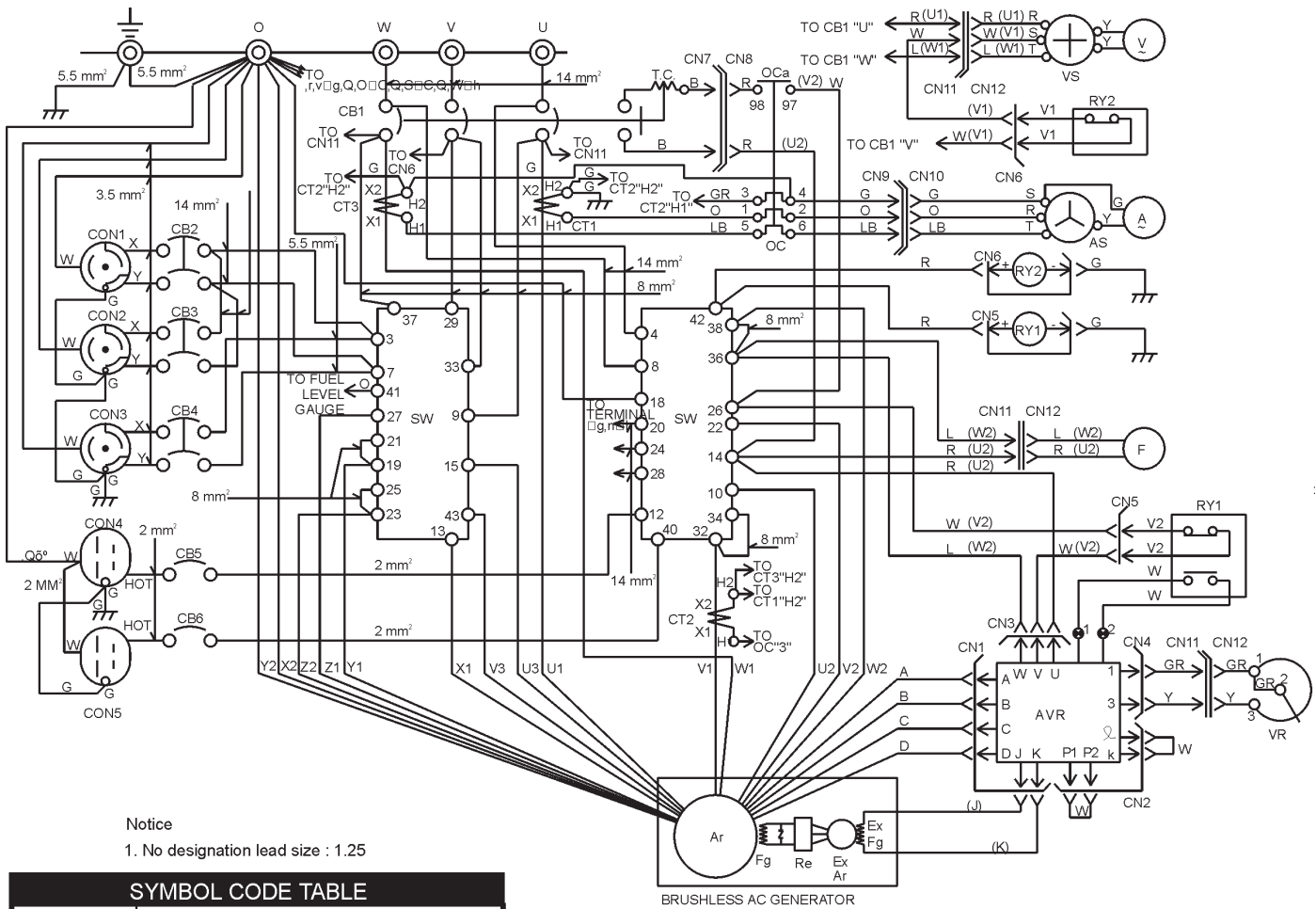

Figure 58. Battery Charger/Jacket Water Heater Power Connections

# DCA-125SSJU2 — GENERATOR WIRING DIAGRAM



**Notice**

1. No designation lead size : 1.25

**SYMBOL CODE TABLE**

SYMBOL	DESIGNATION
Ar	MAIN GENERATOR ARMATURE WINDING
Fg	MAIN GENERATOR FIELD WINDING
ExAr	EXCITER ARMATURE WINDING
ExFg	EXCITER FIELD WINDING
Re	RECTIFIER
AVR	AUTOMATIC VOLTAGE REGULATOR
VR	VOLTAGE REGULATOR (RHEOSTAT)
CT 1,2,3	CURRENT TRANSFORMER
AS	CHANGE-OVER SWITCH, AMMETER
A	AC. AMMETER
VS	CHANGE-OVER SWITCH, VOLTMETER
V	AC. VOLTMETER
F	FREQUENCY METER
Cb1	CIRCUIT BREAKER
CB 2,3,4	CIRCUIT BREAKER
CB 5,6	CIRCUIT BREAKER
CON 1,2,3	RECEPTACLE
CON 4,5	RECEPTACLE
OC	OVER CURRENT RELAY
SW	SELECTOR SWITCH
RY1,2	RELAY UNIT

**COLOR CODE TABLE**

CODE/ WIRE COLOR			
B	BLACK	R	RED
L	BLUE	W	WHITE
BR	BROWN	Y	YELLOW
G	GREEN	LB	LIGHT BLUE
GR	GRAY	LG	LIGHT GREEN
V	VIOLET	O	ORANGE
P	PINK		

Figure 60. Generator Wiring Diagram

**CONNECTOR ARRANGEMENT**

**(WIRING VIEW)**

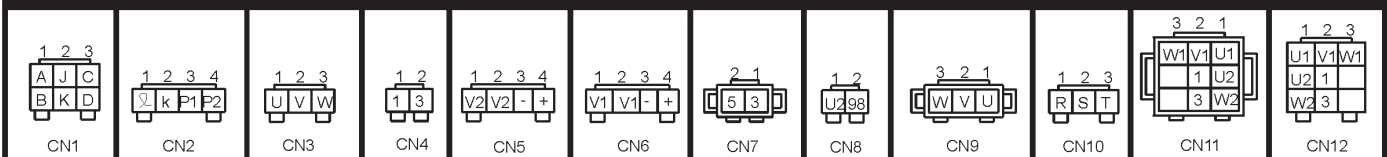

# DCA-125SSJU2 — ENGINE WIRING DIAGRAM (WITH CONTROLLER)

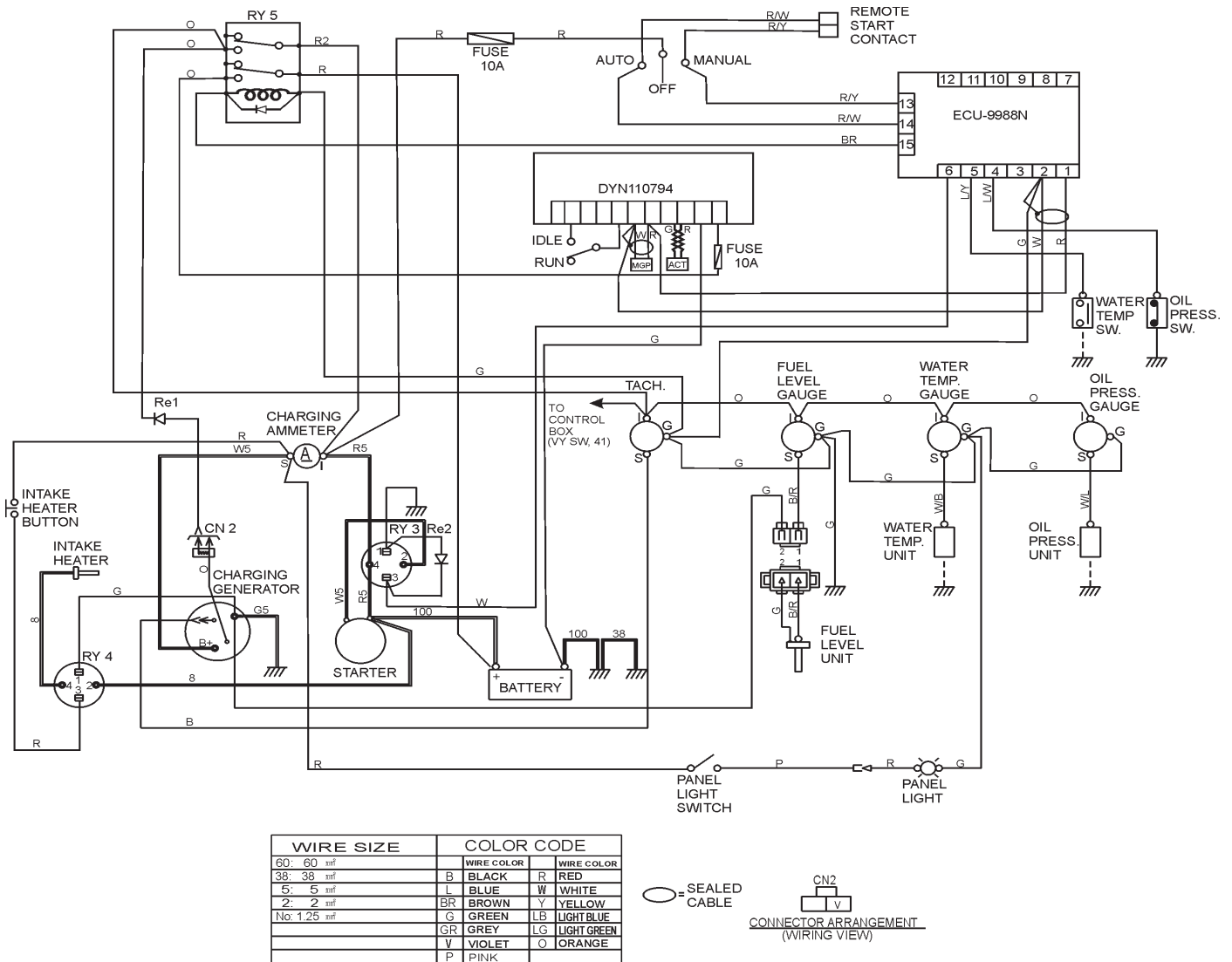

Figure 60. Engine Wiring Diagram(with Controller)

## DCA-125SSJU2 — TROUBLESHOOTING (ENGINE)

Practically all breakdowns can be prevented by proper handling and maintenance inspections, but in the event of a breakdown, use the table shown below and on the next page for diagnosis based on the Engine Troubleshooting (Table 14). If the problem cannot be remedied, consult our company's business office or service plant.

**TABLE 14. ENGINE TROUBLESHOOTING**

SYMPTOM	POSSIBLE PROBLEM	SOLUTION
Engine does not start.	No fuel?	Replenish fuel.
	Air in the fuel system?	Bleed system.
	Water in the fuel system?	Remove water from fuel tank.
	Fuel pipe clogged?	Clean fuel pipe.
	Fuel filter clogged?	Clean or change fuel filter.
	Excessively high viscosity of fuel or engine oil at low temperature?	Use the specified fuel or engine oil.
	Fuel with low cetane number?	Use the specified fuel.
	Fuel leak due to loose injection pipe retaining nut?	Tighten nut.
	Incorrect injection timing?	Adjust.
	Fuel cam shaft worn?	Replace.
	Injection nozzle clogged?	Clean injection nozzle.
	Injection pump malfunctioning?	Repair or replace.
	Seizure of crankshaft, camshaft, piston, cylinder liner or bearing?	Repair or replace.
	Compression leak from cylinder?	Replace head gasket, tighten cylinder head bolt, glow plug and nozzle holder.
	Improper valve timing?	Correct or replace timing gear.
Piston ring and liner worn?	Replace.	
Excessive valve clearance?	Adjust.	
Starter does not run.	Starter malfunctioning?	Repair or replace.
	Wiring disconnected?	Connect wiring.

# DCA-125SSJU2 — TROUBLESHOOTING (ENGINE)

## TABLE 14. ENGINE TROUBLESHOOTING (CONTINUED)

SYMPTOM	POSSIBLE PROBLEM	SOLUTION
Engine revolution is not smooth.	Fuel filter clogged or dirty?	Clean or change.
	Air cleaner clogged?	Clean or change.
	Fuel leak due to loose injection pipe retaining nut?	Tighten nut.
	Injection pump malfunctioning?	Repair or replace.
	Incorrect nozzle opening pressure?	Adjust.
	Injection nozzle stuck or clogged?	Repair or replace.
	Fuel over flow pipe clogged?	Clean.
	Governor malfunctioning?	Repair.
Either white or blue exhaust gas is observed.	Excessive engine oil?	Reduce to the specified level.
	Piston ring and liner worn or stuck?	Repair or replace.
	Incorrect injection timing?	Adjust.
	Deficient compression?	Adjust top clearance.
Either black or dark gray exhaust gas is observed.	Overload?	Lessen the load.
	Low grade fuel used?	Use the specified fuel.
	Fuel filter clogged?	Clean or change.
	Air cleaner clogged?	Clean or change.
	Deficient nozzle injection?	Repair or replace the nozzle.
Deficient output.	Incorrect injection timing?	Adjust.
	Engine's moving parts seem to be seizing?	Repair or replace.
	Uneven fuel injection?	Repair or replace the injection pump.
	Deficient nozzle injection?	Repair or replace the nozzle.
	Compression leak?	Replace head gasket, tighten cylinder head bolt, glow plug and nozzle holder.

## DCA-125SSJU2 — TROUBLESHOOTING (GENERATOR)

Practically all breakdowns can be prevented by proper handling and maintenance inspections, but in the event of a breakdown, use the table shown below for diagnosis based on the Generator Troubleshooting (Table 15). If the problem cannot be remedied, consult our company's business office or service plant.

**TABLE 15. GENERATOR TROUBLESHOOTING**

SYMPTOM	POSSIBLE PROBLEM	SOLUTION
No Voltage Output	AC Voltmeter defective?	Check output voltage using a voltmeter.
	Is wiring connection loose?	Check wiring and repair.
	Is AVR defective?	Replace if necessary.
	Defective Rotating Rectifier?	Check and replace.
Low Voltage Output	Is engine speed correct?	Turn engine throttle lever to "High".
	Is wiring connections loose?	Check wiring and repair.
	Defective AVR?	Replace if necessary.
High Voltage Output	Is wiring connections loose?	Check wiring and repair.
	Defective AVR?	Replace if necessary.
Circuit Breaker Tripped	Short Circuit in load?	Check load and repair.
	Over current?	Confirm load requirements and reduce.
	Defective circuit breaker?	Check and replace.
	Over current Relay actuated?	Confirm load requirement and replace.

## DCA-125SSJU2 — TROUBLESHOOTING (MPEC)

Practically all breakdowns can be prevented by proper handling and maintenance inspections, but in the event of a breakdown, use the table shown below for diagnosis based on the MPEC Troubleshooting (Table 16). If the problem cannot be remedied, consult our company's business office or service plant.

**TABLE 16. ENGINE CONTROLLER TROUBLESHOOTING (MPEC)**

Sympton	Possible Cause	Solution
Low oil pressure light is on.	Low oil level?	Fill oil level.
	Oil pressure sending unit failure?	Replace oil pressure sending unit.
	Time delay malfunction in Controller?	Refer to dealer.
	Wire shorted?	Inspect/repair wire.
Low coolant level light is on.	Low coolant level?	Fill coolant level.
	Sending unit failure?	Replace sending unit.
	Low battery voltage?	Replace/charge battery.
High coolant temperature light is on.	Fan belt tension incorrect?	Tighten/replace fan belt.
	Air flow is not circulation through radiator?	Clean/repair radiator grill.
	Doors open?	Close doors.
	Exhaust leaking?	Replace/repair gaskets or faulty part.
	Generator being overloaded?	Check/reduce load.
	Thermostat failure?	Replace thermostat.
	Air intake blocked?	Clear all air intakes.
	Temperature switch failure?	Replace temperature switch.
Overcrank light is on.	No or low Fuel?	Fill fuel level.
	Controller needs to be calibrated?	Refer to dealer.
Overspeed light is on.	RPM engine speed too high?	Adjust RPM.
	Governor actuator needs to be adjusted?	Adjust governor actuator.
	Governor controller needs to be adjusted?	Adjust governor controller.
	Engine Controller needs to be calibrated?	Refer to dealer.
Loss of MPU light(s) or on.	Magnetic pick up out of adjustment?	Adjust magnetic pick up.
	Magnetic pick up dirty?	Clean magnetic pick up.

# DCA-125SSJU2 — EXPLANATION OF CODE IN REMARKS COLUMN

How to read the marks and remarks used in this parts book.

## Items Found In the “Remarks” Column

Serial Numbers-Where indicated, this indicates a serial number range (inclusive) where a particular part is used.

Model Number-Where indicated, this shows that the corresponding part is utilized only with this specific model number or model number variant.

## Items Found In the “Items Number” Column

All parts with same symbol in the number column, \*, #, +, %, or <, belong to the same assembly or kit

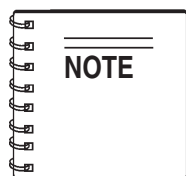

If more than one of the same reference number is listed, the last one listed indicates newest (or latest) part available.

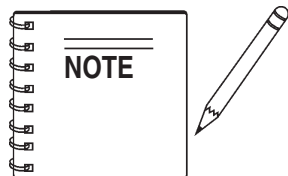

*The contents of this catalog are subject to change without notice.*

## **DCA-125SSJU2 W/JOHN DEERE 6080TF250 DIESEL ENGINE 1 TO 3 UNITS**

<b>Qty.</b>	<b>P/N</b> .....	<b>Description</b>
1	0601820671 .....	AUTOMATIC VOLTAGE REGULATOR
1	0601840073 .....	RHEOSTAT VOLTAGE REGULATOR
1	0601840121 .....	KNOB, RHEOSTAT
1	47230107 .....	KNOB, SELECTOR SWITCH
1	M3310500403 .....	RADIATOR HOSE, UPPER
1	M3310500503 .....	RADIATOR HOSE, LOWER
5	0602041290 .....	OIL FILTER
5	0602042590 .....	FUEL FILTER
5	0602046377 .....	AIR ELEMENT
1	0602122272 .....	UNIT, OIL PRESSURE
1	0602123261 .....	UNIT, WATER TEMPERATURE
1	0601810245 .....	BULB, ALARM LAMP
1	0602011491 .....	FAN BELT
1	0602122281 .....	OIL SHUTDOWN SWITCH
2	0601808803 .....	CIRCUIT BREAKER, QOU120B 20A
3	0601808804 .....	CIRCUIT BREAKER, QOU250B 50A
1	M9310000103 .....	ENCLOSURE CAP
1	M1483600204 .....	ENCLOSURE CAP CHAIN ASSEMBLY
1	ECU9988NJD .....	CONTROLLER ECU

# DCA-125SSJU2 — NAMEPLATE AND DECALS

## NAMEPLATE AND DECALS

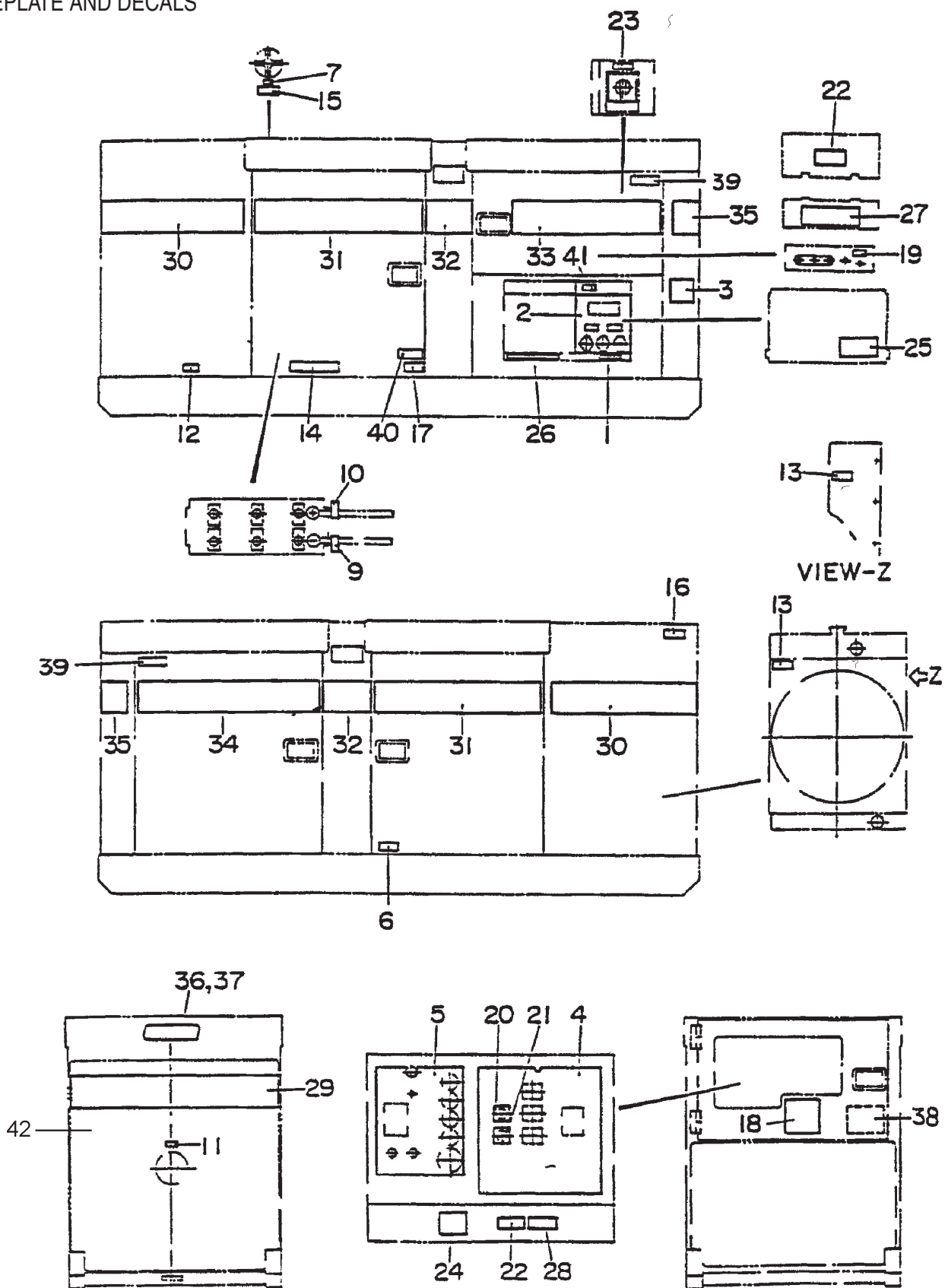

# DCA-125SSJU2 — NAMEPLATE AND DECALS

## NAMEPLATE AND DECALS

<u>NO.</u>	<u>PART NO.</u>	<u>PART NAME</u>	<u>QTY.</u>	<u>REMARKS</u>
1	M1550000204	DECAL, NOTE .....	1	M15000020
2	M1550000703	DECAL, AUXILLIARY OUTPUT .....	1	M15000070
3	M3550000004	DECAL, NOTE .....	1	M35000000
4	M3550000102	DECAL, GENERATOR CONTROL .....	1	M35000010
5	M3550000202	DECAL, ENGINE OPERATING, M35000020 .....	1	S/N7500001 TO S/N7500507
	M3550000212	DECAL, ENGINE OPERATING, M35000020 .....	1	S/N7500508~
6	M9500000004	DECAL, OIL DRAIN PLUG .....	1	M90000000
7	M9500100004	DECAL, WATER .....	1	M90010000
8	M9500100104	DECAL, WATER DRAIN PLUG M90010010 .....	1	S/N7500001 TO 7500307
9	M9500300004	DECAL, NEGATIVE .....	1	M90030000
10	M9500300104	DECAL, POSITIVE .....	1	M900500000
11	M9500500004	DECAL, DIESEL FUEL .....	1	M90050000
12	M9500500104	DECAL, FUEL DRAIN PLUG .....	1	M90050010
13	M9503000004	DECAL, WARNING .....	1	M9030000
14	M9503000103	DECAL, WATER OIL CHECK .....	1	M90310010
15	M9503100004	DECAL, WARNING .....	1	M90310000
16	M9503200004	DECAL, WARNING .....	1	M90320000
17	M9510100004	DECAL, CAUTION .....	1	M91010000
18	M9510200002	DECAL, MQ .....	1	M91020000
19	M9520000004	DECAL, GROUND .....	1	M92000000
20	M9520000104	DECAL, AMMETER CHANGE-OVER SW. ....	1	M92000010
21	M9520000204	DECAL, VOLTMETER CHANGE-OVER SW. ....	1	M92000020
22	M9520100004	DECAL, WARNING .....	2	M92010000
23	M9520100204	DECAL, CAUTION .....	1	M92010020A
24	M9520100304	DECAL, SAFETY INSTRUCTIONS .....	1	M92010030
25	M9520100404	DECAL, DANGER .....	1	M92010040
26	M9520100503	DECAL, WARNING .....	1	M92010050
27	M9520200003	DECAL, CONNECTION OF OUTPUT CABLE ...	1	M92020010
28	M9520200104	DECAL, OVER CURRENT RELAY .....	1	M92020010
29	M9560100003	STRIPE, WHISPERWATT	1	
30	M3560100103	STRIPE, MQ POWER	2	
31	M3560100203	STRIPE	2	
32	M3560100404	STRIPE	2	
33	M3560100303	STRIPE, 125	1	
34	M3650100503	STRIPE, 125	1	
35	M3650100604	STRIPE	3	
36	M0600500090	EMBLEM	1	
37	0021106015	MACHINE SCREW	2	
38	M3552000103	DECAL, OPERATING PROC., M35200010 .....	1	S/N7500508~
39	B152000103	DECAL, CAUTION, B15200010 .....	2	S/N7500508~
40	C95053000004	DECAL, CAUTION, C90530000 .....	1	S/N7500508~
41	9039209064	DECAL, START CONTACT, S-4468 .....	1	S/N7500508~
42	TBD	DECAL, FUELING PROCEDURE .....	1	

# DCA-125SSJU2 — GENERATOR ASSY.

GENERATOR ASSY.

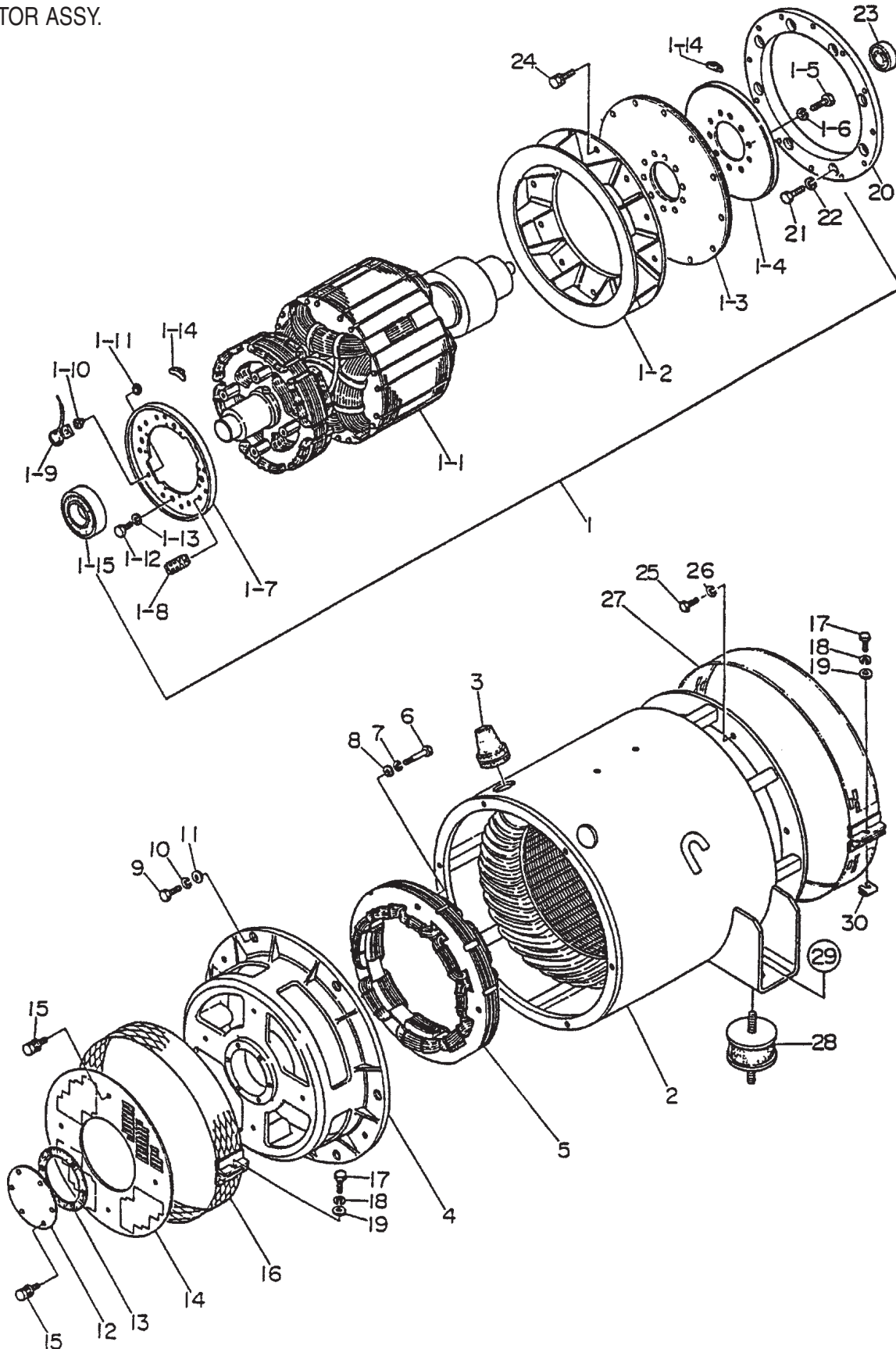

# DCA-125SSJU2 — GENERATOR ASSY.

## GENERATOR ASSY.

<u>NO.</u>	<u>PART NO.</u>	<u>PART NAME</u>	<u>QTY.</u>	<u>REMARKS</u>
1	C0110000002	ROTOR ASSY.	1	
1-1		FIELD ASSY.	1	
1-2	8131070013	FAN	1	
1-3	8131611014	COUPLING DISK	8	
1-4	8131015003	BALANCING PLATE	1	
1-5	0012112035	HEX. HEAD BOLT	10	
1-6	0042612000	LOCK WASHER	10	
1-7	8101026013	SET PLATE	1	
1-8	0601821349	RECTIFIER .....	2	PT3610
1-9	0601822601	SURGE ABSORBER .....	1	ERZM14JK621A
1-10	8001020004	INSULATOR WASHER	1	
1-11	8001020504	INSULATOR WASHER	1	
1-12	0010110020	HEX. HEAD BOLT	4	
1-13	0040010000	LOCK WASHER	4	
1-14	0601000209	BALANCING WEIGHT KIT	1	
1-15	0071906312	BEARING .....	1	6312 DDU C3
2	8131340213	STRATOR ASSY.	1	
3	0845041804	GROMMET	2	
4	8131315202	END BRACKET	1	
5	8101350013	FIELD ASSY. EXCITER	1	
6	0012110060	HEX. HEAD BOLT	4	
7	0042610000	LOCK WASHER	4	
8	031110160	PLAIN WASHER .....	4	REPLACES 0041210000
9	0010112035	HEX. HEAD BOLT	6	
10	0040012000	LOCK WASHER	6	
11	031112230	PLAIN WASHER .....	6	REPLACES 0041212000
12	8131310104	COVER, BEARING	1	
13	8131312204	GASKET, BEARING	1	
14	8131331003	COVER, END BRACKET	1	
15	0105050616	HEX. HEAD BOLT .....	10	REPLACES 0017106012

# DCA-125SSJU2 — GENERATOR ASSY. (CONT.)

GENERATOR ASSY. (CONT.)

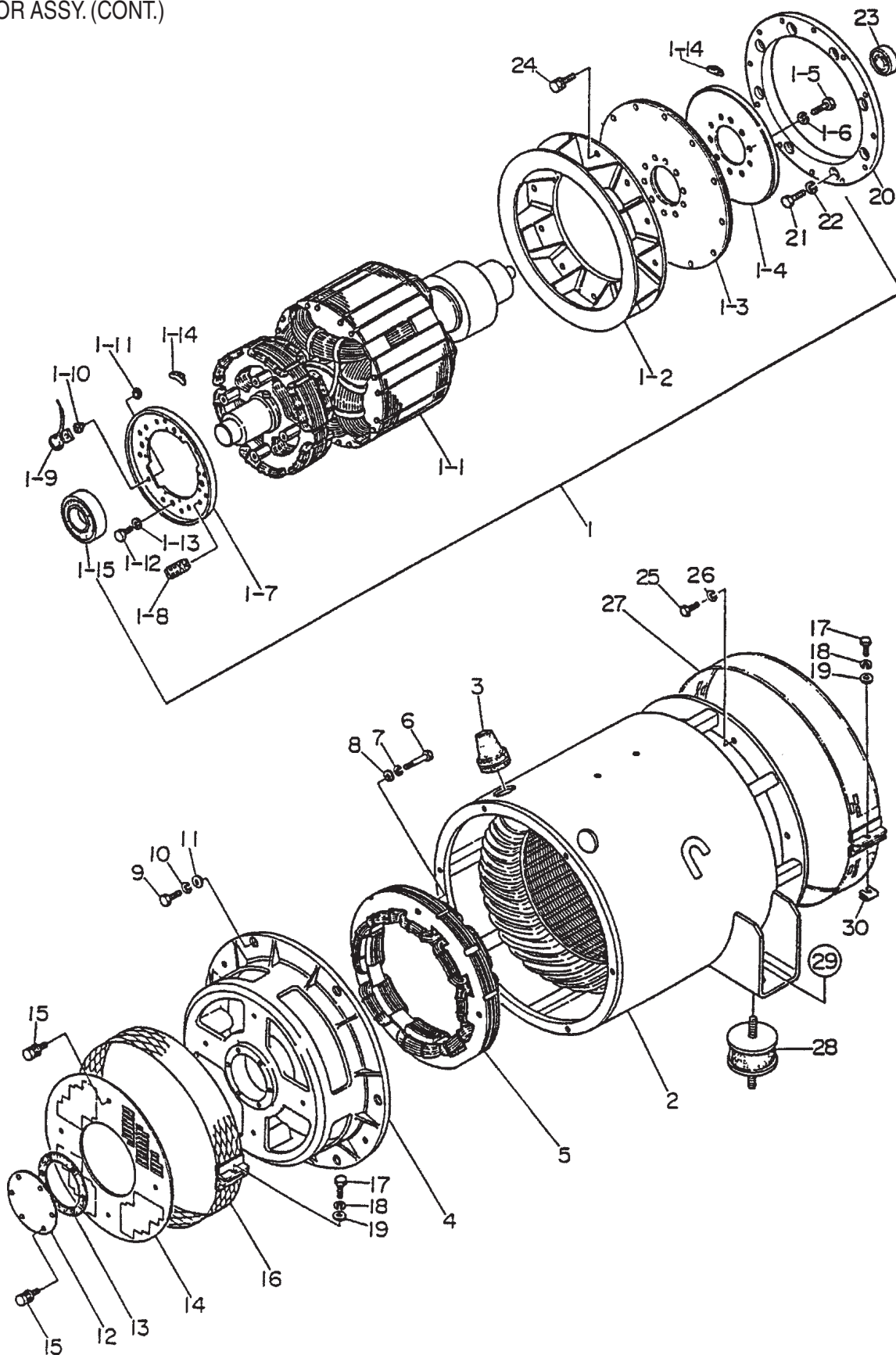

## DCA-125SSJU2 — GENERATOR ASSY. (CONT.)

### GENERATOR ASSY. (CONT.)

<u>NO.</u>	<u>PART NO.</u>	<u>PART NAME</u>	<u>QTY.</u>	<u>REMARKS</u>
16	8101333003	COVER, END BRACKET	1	
17	0010106030	HEX. HEAD BOLT	2	
18	0040006000	LOCK WASHER	2	
19	952404470	PLAIN WASHER .....	2	REPLACES 0041206000
20	M3163400003	COUPLING RING	1	
21	0013904044	HEX. HEAD BOLT .....	8	S/N 7500001 TO 7500242
21	0343204150	HEX. HEAD BOLT .....	8	S/N 7500243~
22	EM923344	LOCK WASHER .....	8	REPLACES 0043604000
23	0070506306	BEARING .....	1	6306ZZ
24	0012810030	HEX. HEAD BOLT	12	
25	0012810030	HEX. HEAD BOLT .....	12	S/N 7500001 TO 7500242
25	0010310035	HEX. HEAD BOLT .....	12	S/N 7500243~
26	0042510000	LOCK WASHER .....	12	S/N 7500001 TO 7500242
27	8131332003	COVER, FAN .....	1	S/N 7500001 TO 7500242
27	8131332014	COVER, FAN .....	1	S/N 7500243~
28	0605000063	RUBBER SUSPENSION	2	
29	00300165000	HEX. NUT	2	
29	0040016000	LOCK WASHER	2	
30	020106050	NUT .....	1	REPLACES 0600815000
		.....		S/N 7500004~

# DCA-125SSJU2 — CONTROL BOX ASSY.

CONTROL BOX ASSY.

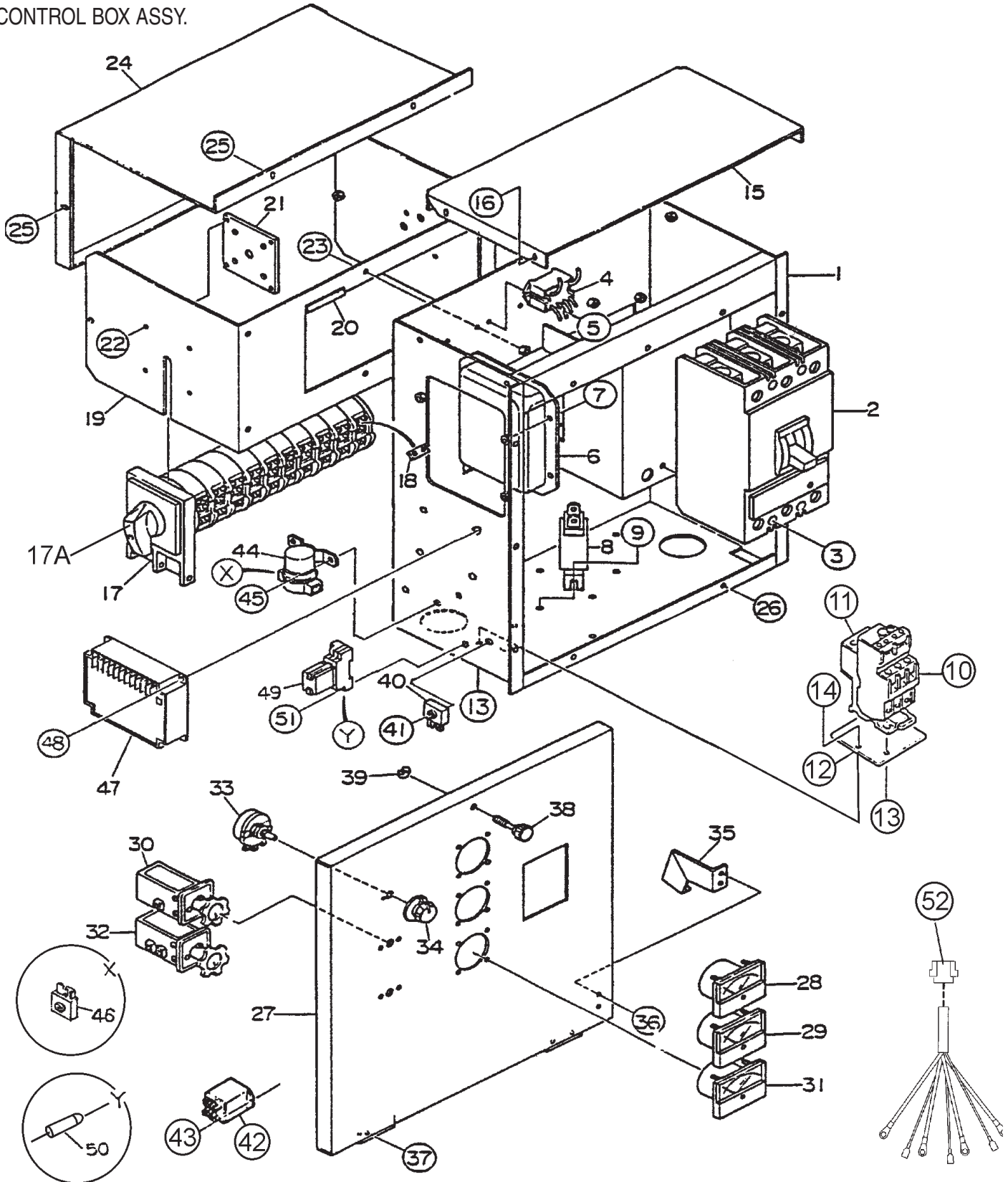

# DCA-125SSJU2 — CONTROL BOX ASSY.

## CONTROL BOX ASSY.

<u>NO.</u>	<u>PART NO.</u>	<u>PART NAME</u>	<u>QTY.</u>	<u>REMARKS</u>
1	M3213000102	CONTROL BOX .....	1	S/N 7500001 TO 7500048
1	M3213000112	CONTROL BOX .....	1	S/N 7500049 TO 7500222
1	M3213000122	CONTROL BOX .....	1	S/N 7500223 TO 7500507
1	M3213000132	CONTROL BOX .....	1	S/N 7500508~
2	0601808813	CIRCUIT BREAKER .....	1	LAF363001021 3P 300A
3	0021006080	MACHINE SCREW	4	
4	0601823863	RELAY UNIT .....	2	MSA9013A
5	0021304015	MACHINE SCREW .....	4	REPLACES 0027104015
6	0601820671	AUTOMATIC VOLTAGE REGULATOR .....	1	NTA5A2DB
7	0027105010	MACHINE SCREW .....	4	S/N 7500001 TO 7500222
7	0027105015	MACHINE SCREW .....	4	S/N 7500223~
8	0601806118	CURRENT TRANSFORMER .....	3	814943 200/5A
9	011808015	MACHINE SCREW .....	6	REPLACES 0027106015
10	0601820845	OVER CURRENT RELAY .....	1	LR2D1308
11	0601820846	OVER CURRENT RELAY .....	1	LA7D1064
12	M1260600004	FITTING BRACKET .....	1	S/N 7500001 TO 7500222
13	0021304015	MACHINE SCREW .....	2	REPLACES 0027104015
13	0030004000	HEX. NUT .....	2	REPLACES 0207004000
14	0027105020	MACHINE SCREW	4	
15	M3213500003	CONTROL BOX COVER .....	1	S/N 7500001 TO 7500048
15	M3213500013	CONTROL BOX COVER .....	1	S/N 7500049~
16	011106015	HEX. HEAD BOLT .....	4	REPLACES 0016906015
17	M3923100004	SELECTOR SWITCH .....	1	VY125
17A	47230107	KNOB, SELECTOR SWITCH	1	
18	M3276600004	SPACER	8	
19	M3213600003	SWITCH BRACKET	1	
20	0330000295	EDGING	2	
21	M3260500004	SWITCH BOARD	1	
22	0020004010	MACHINE SCREW .....	4	REPLACES 0021104010
23	011106015	HEX. HEAD BOLT .....	6	REPLACES 0016906015
24	M3213600114	SWITCH COVER .....	1	REPLACES M3213600104
25	011106015	HEX. HEAD BOLT .....	4	REPLACES 0016906015
26	011106015	HEX. HEAD BOLT .....	10	REPLACES 0016906015
26	0040506000	TOOTHED WASHER	1	
27	M3223000103	CONTROL PANEL	1	
28	0601807630	FREQUENCY METER,264250DJDJ9 .....	1	S/N 7500001 TO 7500842
28	0601807641	FREQUENCY METER,FCF-6 45-65HZ 240V .....	1	S/N 7500843~

# DCA-125SSJU2 — CONTROL BOX ASSY. (CONT.)

CONTROL BOX ASSY. (CONT.)

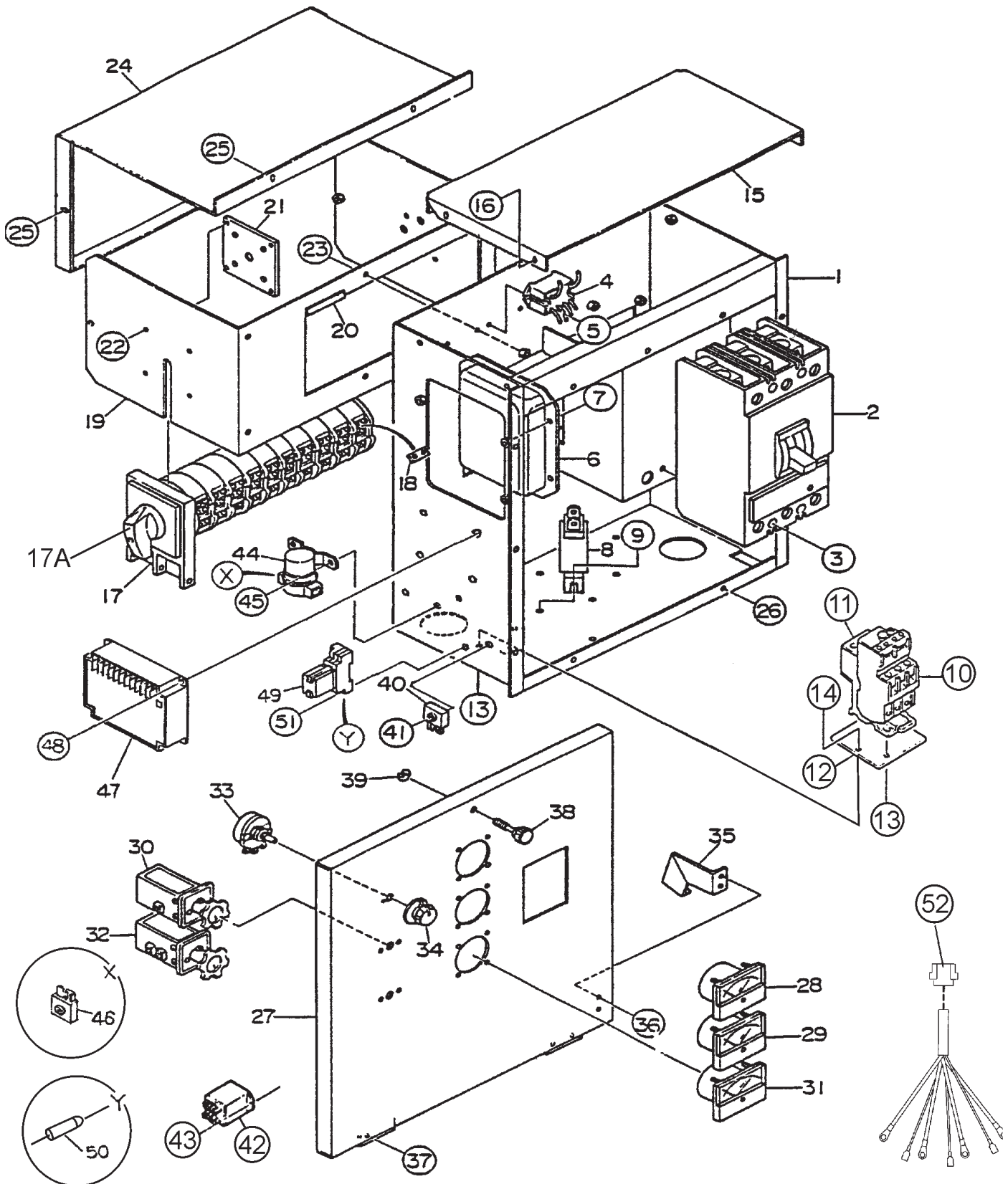

## DCA-125SSJU2 — CONTROL BOX ASSY. (CONT.)

### CONTROL BOX ASSY. (CONT.)

<u>NO.</u>	<u>PART NO.</u>	<u>PART NAME</u>	<u>QTY.</u>	<u>REMARKS</u>
29	0601808953	AC AMMETER, 260240LSLS1JCA .....	1 .....	S/N 7500001 TO 7500842
29	0601808988	AC AMMETER, ACF-6 - 200A,0-400A/5A ...	1 .....	S/N 7500843~
30	0601801040	CHANGE-OVER SWITCH, AMMETER .....	1 .....	SL2AS
31	0601806813	AC VOLTMETER, 260244SJSJ1 .....	1 .....	S/N 7500001 TO 7500842
31	0601806859	AC AMMETER, SCF-6 0-600V .....	1 .....	S/N 7500843~
32	0601801041	CHANGE-OVER SWITCH, VOLTMETER ....	1 .....	SL2VS
33	0601840073	RHEOSTAT (VOLTAGE REGULATOR) .....	1 .....	RA20A2SE102BJ 2W 1K OHM
34	0601840121	KNOB	1	
35	M122310004	STOPPER	1	
36	0027105015	MACHINE SCREW	2	
37	0027105015	MACHINE SCREW	1	
38	M9220100004	SET SCREW	1	
39	0080200007	SNAP RING	1	
40	0601823240	RECTIFER .....	1 .....	DE4503
41	0027104020	MACHINE SCREW .....	1 .....	S/N 7500001 TO 7500307
41	0027105020	MACHINE SCREW .....	1 .....	S/N 7500308 TO 7500507
41	0027104020	MACHINE SCREW .....	1 .....	S/N 7500508~
42	0602200478	EMERGENCY RELAY, 10701606023 .....	1 .....	S/N 7500001 TO 7500507
43	0027105040	MACHINE SCREW .....	2 .....	S/N 7500001 TO 7500507
44	0602202592	STARTER RELAY .....	1 .....	AT141011
45	011808015	MACHINE SCREW .....	2 .....	REPLACES 0027106015
46	0601823240	RECTIFER, DE4503 .....	1 .....	S/N 7500508~
47	DYN110794000012	CONTROLLER .....	1 .....	REPL. 0602202599 S/N 7500508~
47	MPS6724	SPEED SENSOR, MAGNETIC PICK UP ...	1 .....	REPLACES 0602120485
48	0027105015	MACHINE SCREW .....	4 .....	S/N 7500508~
49	0601823768	RELAY, LY2US12VD .....	1 .....	S/N 7500508 TO 7500542
49	LY2US12VDC	RELAY .....	1 .....	REPL. 0601827656 S/N 7500543~
49	PTF08AE	BASE, RELAY SOCKET .....	1 .....	REPL. 0601823109 S/N 7500508~
49	PYCA1	CLIP .....	2 .....	REPL. 0601824400 S/N 7500508~
50	0601823223	RECTIFER .....	1 .....	30D4 S/N 7500508 TO 7500542
51	0027104020	MACHINE SCREW .....	2 .....	S/N 7500508~
52	M3246700304	WIRE HARNESS, GENERATOR	1	

# DCA-125SSJU2 — ENGINE AND RADIATOR ASSY.

ENGINE AND RADIATOR ASSY.

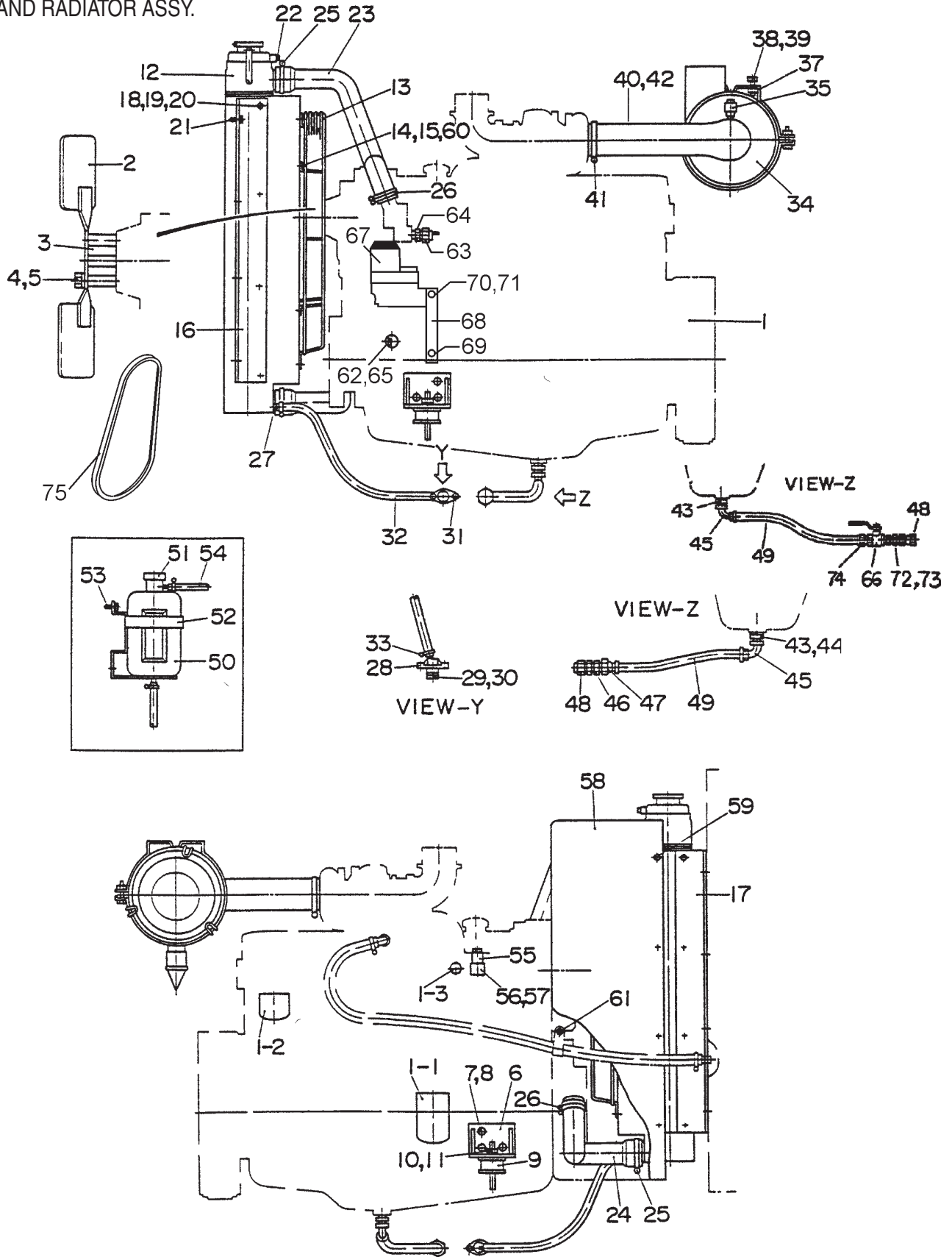

# DCA-125SSJU2 — ENGINE AND RADIATOR ASSY.

## ENGINE AND RADIATOR ASSY.

<u>NO.</u>	<u>PART NO.</u>	<u>PART NAME</u>	<u>QTY.</u>	<u>REMARKS</u>
1	M3923200004	ENGINE .....	1	JOHN DEERE 6068TF
1-1	0602041290	ELEMENT, OIL FILTER .....	1	RE59754A
1-2	0602042590	ELEMENT, FUEL FILTER .....	1	RE62418
1-3	0602014297	ELECTRIC HEATER .....	1	RE29658
1-3	RE502668	ELECTRIC HEATER ASSY. ....		S/N 7500263-
2	0602060010	BLOWER FAN .....	1	422198
3	0602061000	FAN SPACER .....	1	R81911
4	0012110090	HEX. HEAD BOLT .....	4	S/N 7500001 TO 7500003
4	0012110095	HEX. HEAD BOLT	4	
5	030210250	LOCK WASHER .....	4	REPLACES 0042510000
6	M2303200303	ENGINE FOOT	2	
7	0131151240	HEX HEAD BOLT .....	6	REPLACES 0010312030
8	0040012000	LOCK WASHER	6	
9	0605000060	RUBBER SUSPENSION	2	
10	0030012000	HEX. NUT	2	
11	0040012000	LOCK WASHER	2	
12	0602011988	RADIATOR, RE52824 .....	1	S/N 7500001 TO 7500003
12	0602012723	RADIATOR, C2810060000 .....	1	S/N 7500308 TO 7500952
12	0602012747	RADIATOR, C281-009-003 .....	1	S/N 7500953
12-1	0602011067	CAP .....	1	S/N 7500001 TO 7500307
12-1	0602011066	CAP .....	1	S/N 7500308~
12-2	0199101200	HOSE .....	1	S/N 7500308~
13	0602010795	FAN COVER, C2810044210 .....	1	S/N 7500001 TO 7500307
14	0013006008	HEX. HEAD BOLT .....	8	S/N 7500001 TO 7500307
15	0043106000	PLAIN WASHER .....	8	S/N 7500001 TO 7500307
16	M3310200204	RADIATOR BRACKET .....	1	S/N 7500001 TO 7500307
17	M3310200404	RADIATOR BRACKET .....	1	S/N 7500001 TO 7500307
18	0013006008	S/N 7500001 TO 7500307 .....	8	S/N 7500001 TO 7500307
19	0043006000	LOCK WASHER .....	8	S/N 7500001 TO 7500307
20	0043106000	PLAIN WASHER .....	8	S/N 7500001 TO 7500307
21	011008020	HEX HEAD BOLT .....	8	REPLACES 001690820
22	0468102000	PLUG .....	1	S/N 7500001 TO 7500307
23	M3310500003	RADIATOR HOSE, UPPER .....	1	S/N 7500001 TO 7500307
23	M3310500403	RADIATOR HOSE, UPPER .....	1	S/N 7500308~
24	M3310500103	RADIATOR HOSE, LOWER .....	1	S/N 7500001 TO 7500307
24	M3310500503	RADIATOR HOSE, LOWER .....	1	S/N 7500308~
25	0605515148	HOSE BAND	2	
26	0605515147	HOSE BAND	2	
27	0605512190	HOSE JOINT	1	
28	M2320300103	DRAIN JOINT .....	1	S/N 7500001 TO 7500307
29	M9200200004	DRAIN BOLT .....	1	S/N 7500001 TO 7500307
30	0150000018	O RING .....	1	S/N 7500001 TO 7500307
31	0016906020	HEX HEAD BOLT .....	2	S/N 7500001 TO 7500307
32	0191300580	DRAIN HOSE .....	1	S/N 7500001 TO 7500307
33	0605515189	HOSE BAND	2	S/N 7500001 TO 7500307
34	0602046258	AIR CLEANER .....	1	FRG100297
34	0602046377	ELEMENT, AIR CLEANER .....	1	P778214
35	0602040650	INDICATOR, AIR CLEANER .....	1	RBX002252
36	0603306385	NIPPLE .....	1	S/N 7500001 TO 7500004
37	0602040596	BAND, AIR CLEANER .....	1	P004076
38	011008020	HEX. HEAD BOLT .....	4	REPLACES 0016908020
39	020108060	HEX, NUT .....	4	REPLACES 0207008000
40	M337310003	HOSE, AIR CLEANER	1	
41	0605515146	HOSE BAND .....	1	5035
42	0605515200	HOSE BAND .....	1	5072
43	0602022563	ADAPTER	1	

# DCA-125SSJU2 — ENGINE AND RADIATOR ASSY. (CONT.)

## ENGINE AND RADIATOR ASSY. (CONT.)

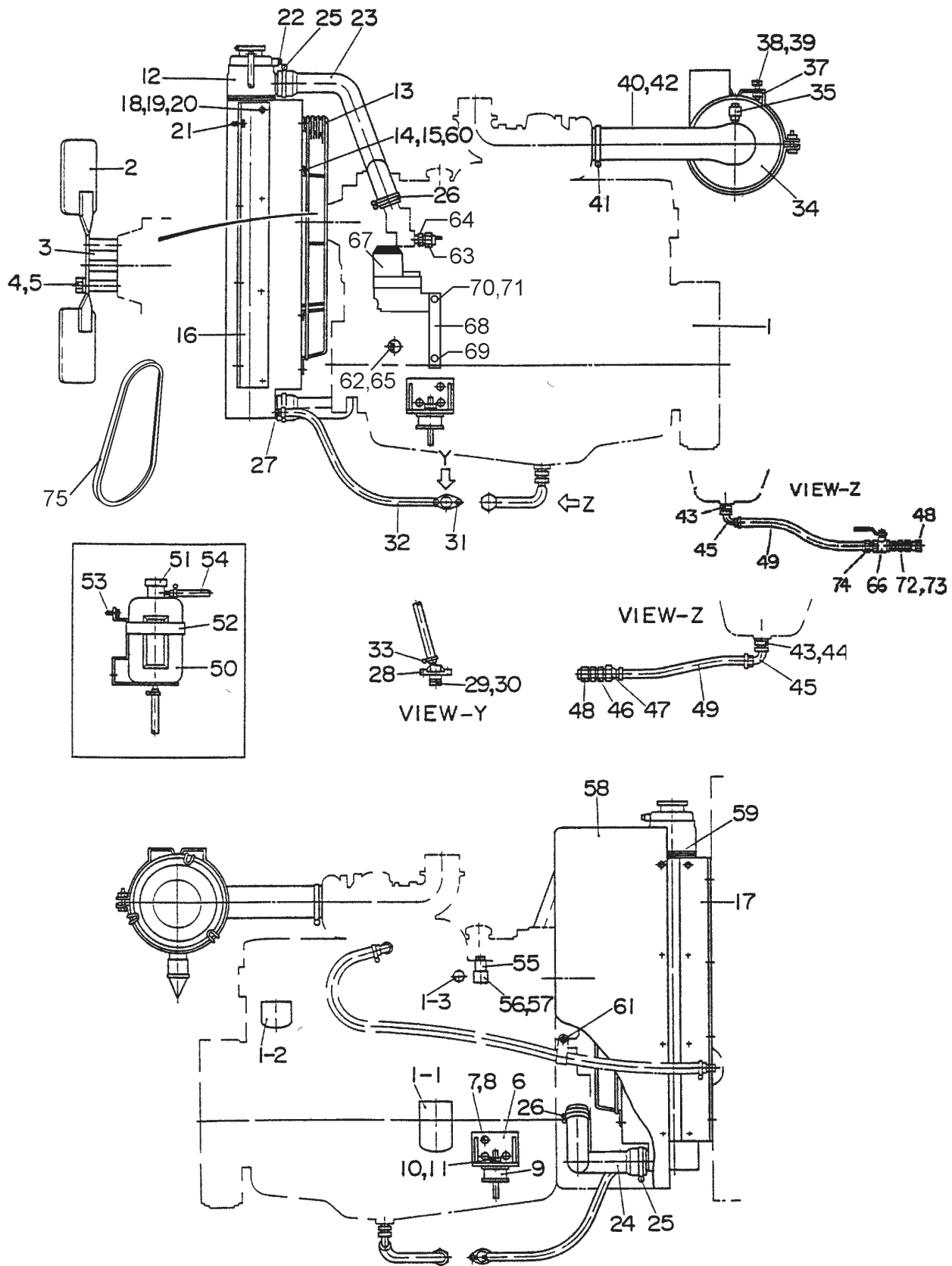

## DCA-125SSJU2 — ENGINE AND RADIATOR ASSY. (CONT.)

### ENGINE AND RADIATOR ASSY. (CONT.)

<u>NO.</u>	<u>PART NO.</u>	<u>PART NAME</u>	<u>QTY.</u>	<u>REMARKS</u>
44	0602021165	O-RING .....	1	S/N 7500001 TO 7500307
45	0602022561	90° ELBOW .....	1	3398210-10+
46	0602022562	UNION, 10WTXWLN5 .....	1	S/N 7500001 TO 7500307
47	0602022792	SWIVEL, 306821010 .....	1	S/N 7500001 TO 7500307
48	0602021070	CAP .....	1	10FNTXS
49	0602021573	DRAIN HOSE .....	1	83610 S/N 7500001 TO 7500307
49	0269200406	DRAIN HOSE .....	1	83610 S/N 7500263~
50	M9300000203	RESERVE TANK	1	
51	06020100900	CAP, RESERVE TANK	1	
52	M3316100104	BRACKET, RESERVE TANK	1	
53	0110080020	HEX.HEAD BOLT .....	2	REPLACES 0016908020
54	0193601080	HOSE	1	
55	M2260600024	RELAY BRACKET	1	
56	0602202597	RELAY, AL64309 .....	1	S/N 7500001 TO 7500262
56	0602202592	RELAY, AT141011 .....	1	S/N 7500263~
57	0017106015	HEX. HEAD BOLT .....	1	S/N 7500001 TO 7500262
57	011808015	MACHINE SCREW .....	2	REPL. 0027106015 S/N 7500263~
58	M3313100004	RADIATOR COVER .....	1	S/N 7500001 TO 7500307
58	M3313100204	RADIATOR COVER .....	1	S/N 7500508~
59	0110080020	HEX. HEAD BOLT .....	4	REPLACES 0016908020
60	0043006000	LOCK WASHER .....	8	S/N 7500001 TO 7500307
61	0110080020	HEX. HEAD BOLT .....	1	REPLACES 0016908020
62	0602122281	OIL SWITCH .....	1	1718939011
63	0602123282	WATER SWITCH .....	1	1518183041
64	M9200100404	ADAPTER	1	
65	M9200100704	ADAPTER .....	1	S/N 7500004~
66	0605511395	VALVE, XV500P8 .....	1	S/N 7500508~
67	DYNC700250000012	ACTUATOR .....	1	REPL. 0602150093 S/N 7500508~
68	M3356200004	STOPPER BRACKET .....	1	S/N 7500508~
69	0016910015	HEX. HEAD BOLT .....	1	REPL. 0017110020 S/N 7500508~
70	0016906020	HEX. HEAD BOLT .....	1	S/N 7500508~
71	0207006000	HEX. NUT .....	1	S/N 7500508~
72	0603306590	CONNECTOR, 10WFTXS .....	1	S/N 7500508~
73	0603300285	ROCK UNIT, 10WLN .....	1	S/N 7500508~
74	0603306395	HOSE JOINT, 30182810 .....	1	S/N 7500508~
75	0602011491	FAN BELT	1	

# DCA-125SSJU2 — ENGINE OPERATING PANEL ASSY.

ENGINE OPERATING PANEL ASSY.

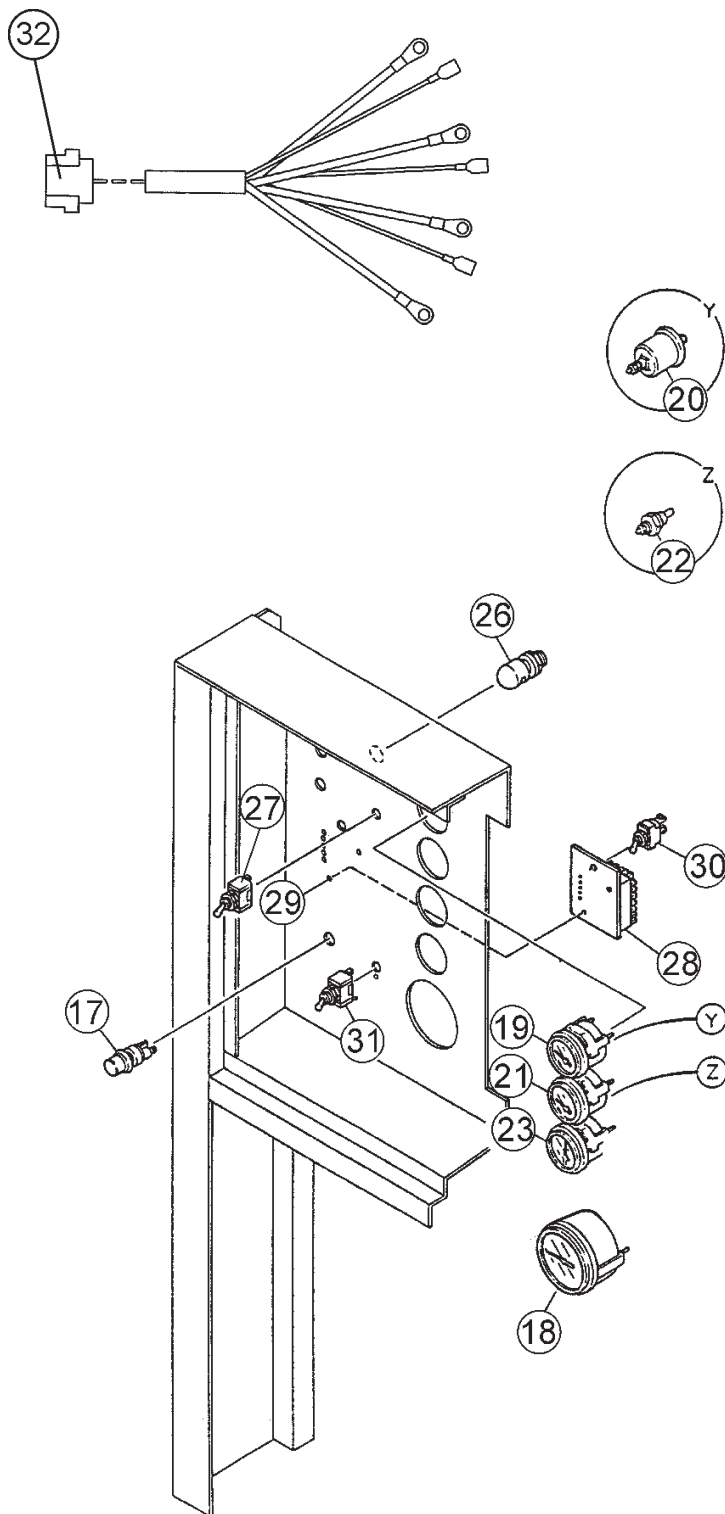

S/N 7500508~

## DCA-125SSJU2 — ENGINE OPERATING PANEL ASSY.

### ENGINE OPERATING PANEL ASSY.

<u>NO.</u>	<u>PART NO.</u>	<u>PART NAME</u>	<u>QTY.</u>	<u>REMARKS</u>
17	0601831585	COLD STARTER BUTTON .....	1 .....	S/N 7500343~
17	0601831588	CAP, 44053 .....	1 .....	S/N 7500343~
18	0602120096	TACHOMETER .....	1 .....	103678
19	0602122093	OIL PRESSURE GAUGE .....	1 .....	100174
20	0602122272	UNIT, OIL PRESSURE	1	
21	0602123092	WATER TEMPERATURE GAUGE .....	1 .....	100182
22	0602123261	UNIT, WATER TEMPERATURE .....	1 .....	0202500
23	0602121080	CHARGING AMMETER .....	1 .....	100158
26	0601810141	PANEL LIGHT .....	1 .....	9826800370
27	0601831330	SWITCH, PANEL LIGHT .....	1 .....	900001
28	ECU9988NJD	ENGINE CONTROLLER .....	1 .....	REPLACES 0602202545
29	0027104035	MACHINE SCREW .....	2 .....	S/N 7500508~
29	0030000400	HEX. NUT .....	2 .....	REPL. 0207004000 S/N 7500508~
30	0601831340	SWITCH, 7562K4 .....	1 .....	S/N 7500508~
30	0600500091	NAME PLATE .....	1 .....	S/N 7500508~
31	0601831395	SWITCH, 7302K36 .....	1 .....	S/N 7500508~
32	M3359200302	WIRE HARNESS, ENGINE .....	1 .....	S/N7500508~

# DCA-125SSJU2 — OUTPUT TERMINAL ASSY.

OUTPUT TERMINAL ASSY.

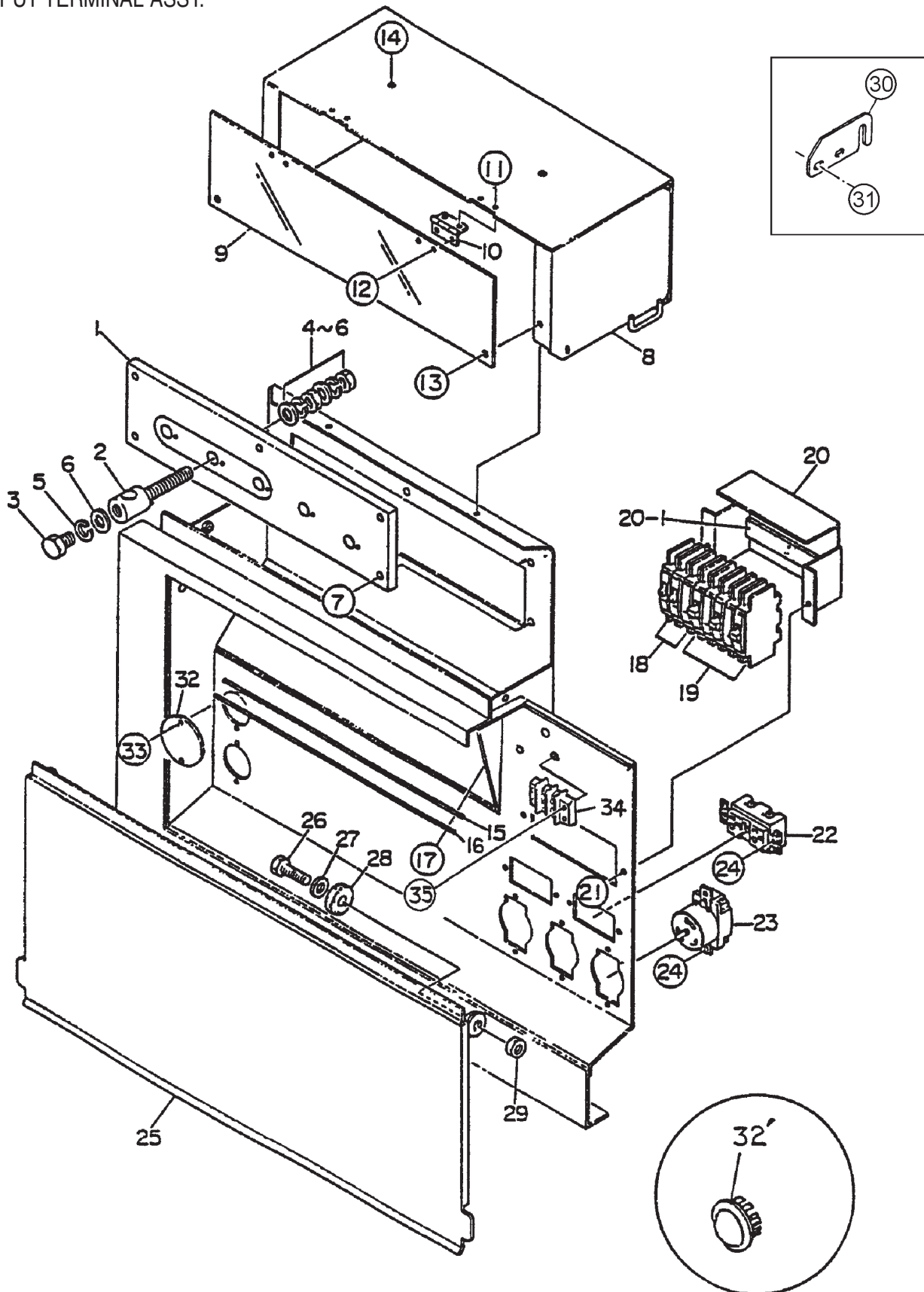

# DCA-125SSJU2 — OUTPUT TERMINAL ASSY.

## OUTPUT TERMINAL ASSY.

<u>NO.</u>	<u>PART NO.</u>	<u>PART NAME</u>	<u>QTY.</u>	<u>REMARKS</u>
1	M3230700003	TERMINAL PANEL	1	
2	M9220100304	OUTPUT TERMINAL BOLT	5	
3	M9220100404	TIE BOLT	5	
4	0039316000	HEX. NUT	10	
5	0040016000	LOCK WASHER	15	
6	0041416000	PLAIN WASHER	20	
7	0012108035	HEX. HEAD BOLT .....	5	REPLACES 0016908035
8	M3236100303	TERMINAL COVER .....	1	S/N 7500001 TO 7500307
8	M3236100313	TERMINAL COVER .....	1	S/N7500308 TO S/N7500507
8	M3238100103	TERMINAL COVER .....	1	S/N7500508~
9	M3236100104	OUTPUT WINDOW	1	
10	0605010040	HINGE	2	
11	0027103010	MACHINE SCREW	4	
11	0207003000	HEX. NUT .....	4	REPLACES 0030003000
11	0041203000	PLAIN WASHER	4	
12	0027103010	MACHINE SCREW	4	
12	0207003000	HEX. NUT .....	4	REPLACES 0030003000
13	011206020	HEX. HEAD BOLT .....	2	REPLACES 0016906020
14	0016906015	HEX. HEAD BOLT	4	
15	M2236400004	CABLE OUTLET COVER .....	1	S/N 7500001 TO 7500034
15	M3236400004	CABLE OUTLET COVER .....	1	S/N 7500035~
16	M2236300004	SUPPORTER,CABLE OUTLET COVER ..	1	S/N 7500001 TO 7500034
16	M3236300004	SUPPORTER,CABLE OUTLET COVER ..	1	S/N 7500035~
17	011206020	HEX. HEAD BOLT .....	6	REPLACES 0016906020
18	0601808803	CIRCUIT BREAKER .....	2	Q0U 120B 1P 20A
19	0601808804	CIRCUIT BREAKER .....	3	Q0U 250B 2P 50A
20	M1260700304	BREAKER FITTING COVER	1	
20-1	0222100150	CUSHION RUBBER	1	
21	011206020	HEX. HEAD BOLT .....	2	REPLACES 0016906020
22	0601812597	RECEPTACLE, GF530EM 125V 20AX2 ...	2	REPLACES 0601812598
23	0601811034	RECEPTACLE, CS6369 250V 50A .....	3	REPLACES 0601812538
24	0021304015	MACHINE SCREW .....	10	REPLACES 0027104015
24	0030004000	HEX. NUT .....	10	REPLACES 0207004000
25	M3236100203	TERMINAL COVER .....	1	S/N 7500001 TO 7500034
25	M3236100213	TERMINAL COVER .....	1	S/N 7500035~
26	012212045	HEX. HEAD BOLT .....	2	REPLACES 0010112045
27	031112230	PLAIN WASHER	2	
28	M9310200004	STAY RUBBER	2	
29	0030012000	NUT	2	
30	M2354200004	SUPPORTER, GOVERNOR ROD .....	1	S/N 7500001 TO 7500507
31	0016906015	HEX. HEAD BOLT .....	2	S/N 7500001 TO 7500507
32	M3455600004	PLUG .....	2	S/N 7500508~
32	0603306775	PLUG .....	2	S/N 7500508~
33	0021304015	MACHINE SCREW .....	4	REPLACES 0027104015
		.....		S/N 7500508~
34	0601815194	TERMINAL, 6041GP02 .....	1	S/N 7500508~
35	0021304015	MACHINE SCREW .....	2	REPLACES 0027104015
		.....		S/N 7500508~

# DCA-125SSJU2 — BATTERY ASSY.

BATTERY ASSY.

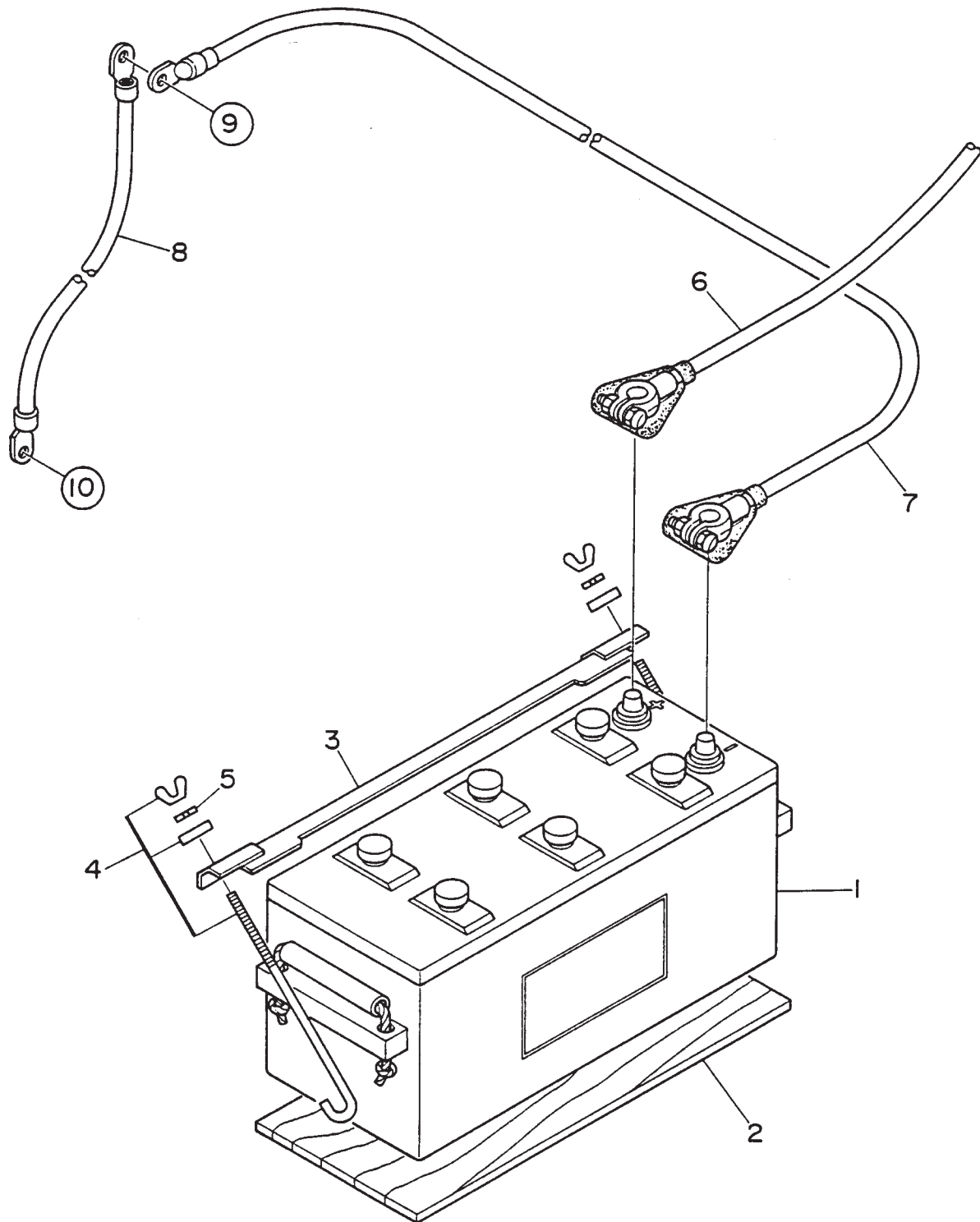

# DCA-125SSJU2 — BATTERY ASSY.

## BATTERY ASSY.

<u>NO.</u>	<u>PART NO.</u>	<u>PART NAME</u>	<u>QTY.</u>	<u>REMARKS</u>
1	GPL-4DA	BATTERY	1	
2	M9310500404	BATTERY SHEET	1	
3	M9103000504	BATTERY BAND	1	
4	0602220921	BATTERY BOLT SET	2	
5	0040006000	LOCK WASHER	2	
6	M3346900004	BATTERY CABLE	1	
7	M3346900104	BATTERY CABLE	1	
8		CABLE .....	1	..... MAKE LOCALLY
9	0017112025	HEX. HEAD BOLT	1	
9	0040512000	TOOTHED WASHER	1	
10	0017110020	HEX. HEAD BOLT	1	
10	0040510000	TOOTHED WASHER	1	

# DCA-125SSJU2 — MUFFLER ASSY.

MUFFLER ASSY.

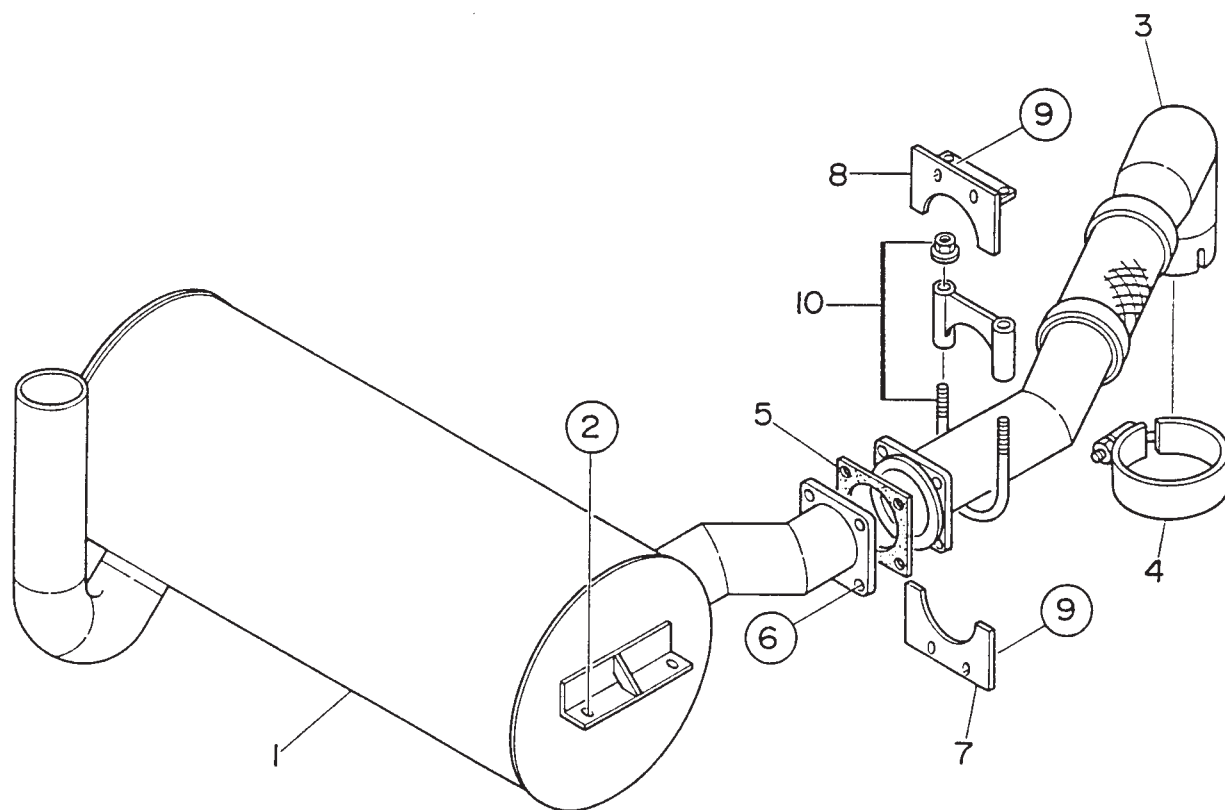

# DCA-125SSJU2 — MUFFLER ASSY.

## MUFFLER ASSY.

<u>NO.</u>	<u>PART NO.</u>	<u>PART NAME</u>	<u>QTY.</u>	<u>REMARKS</u>
1	M3330100002	MUFFLER .....	1 .....	S/N 7500001 TO 7500072
1	0602300167	MUFFLER .....	1 .....	S/N 7500073~
2	012210025	HEX. HEAD BOLT .....	4 .....	REPLACES 0016910025
3	M3333000303	EXHAUST PIPE	1	
4	0602325066	CLAMP	1	
5	M3333200004	GASKET	1	
6	014210040	HEX. HEAD BOLT .....	4 .....	REPLACES 0017110040
7	M33330400304	COVER	1	
8	M3330400403	BRACKET	1	
9	011008020	HEX. HEAD BOLT .....	4 .....	REPLACES 0016908020
10	0602326061	U-BOLT SET .....	1 .....	89547K

# DCA-125SSJU2 — ENCLOSURE ASSY.

ENCLOSURE ASSY.

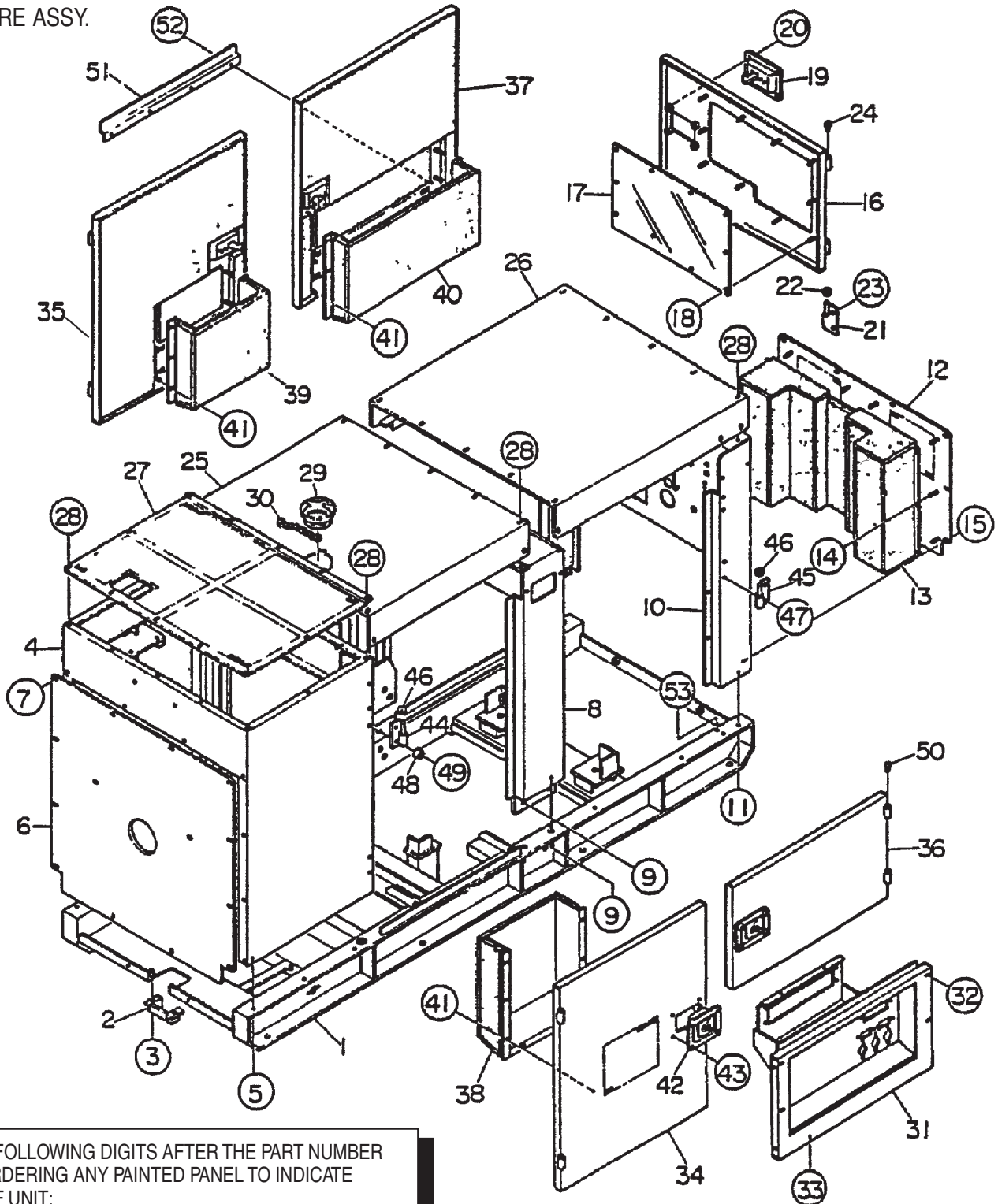

ADD THE FOLLOWING DIGITS AFTER THE PART NUMBER  
WHEN ORDERING ANY PAINTED PANEL TO INDICATE  
COLOR OF UNIT:

- |                 |                      |
|-----------------|----------------------|
| 1-ORANGE        | 5-BLACK              |
| 2-WHITE         | 6-CATERPILLAR YELLOW |
| 3-SPECTRUM GRAY | 7-CATO GOLD          |
| 4-SUNBELT GREEN |                      |

THE SERIAL NUMBER MAY BE REQUIRED.

# DCA-125SSJU2 — ENCLOSURE ASSY.

## ENCLOSURE ASSY.

<u>NO.</u>	<u>PART NO.</u>	<u>PART NAME</u>	<u>QTY.</u>	<u>REMARKS</u>
1	M3413000102	BASE .....	1	S/N 7500001 TO 7500307
1	M3413000112	BASE .....	1	S/N 7500308 TO S/N7500507
1	M3413000122	BASE .....	1	S/N7500508~
2	M1413400004	UNDER COVER	1	
3	012210025	HEX. HEAD BOLT .....	2	REPLACES 0016910025
4	M3423000302	FRONT FRAME .....	1	S/N 7500001 TO S/N 7500307
4	M3423000602	FRONT FRAME .....	1	S/N7500308~
4	M3493100203	ACOUSTIC SHEET .....	1	S/N7500283 TO S/N7500307
4	M3493100503	ACOUSTIC SHEET .....	1	S/N7500308~
5	012210025	HEX. HEAD BOLT .....	6	REPLACES 0016910025
6	M3423200104	COVER, FRONT FRAME	1	
6	M3493100304	ACOUSTIC SHEET	1	
7	011008020	HEX. HEAD BOLT .....	14	REPLACES 0016908020
8	M3433000102	CENTER FRAME	1	
8	M3493200004	ACOUSTIC SHEET	1	
9	0010114040	HEX. HEAD BOLT	12	
9	0030014000	HEX. NUT	12	
9	0040014000	LOCK WASHER	24	
9	031114260	PLAIN WASHER .....	24	REPLACES 0041214000
10	M3443000202	REAR FRAME .....	1	S/N 7500001 TO S/N 7500507
10	M3443000212	REAR FRAME .....	1	S/N7500508~
10	M3493300204	ACOUSTIC SHEET	1	
11	012210025	HEX. HEAD BOLT .....	4	REPLACES 0016910025
12	M3443300203	REAR COVER	1	
13	M3443300303	DUCT, REAR COVER	1	
13	M3493300303	ACOUSTIC SHEET	1	
14	0207006000	HEX. NUT	12	
15	011008020	HEX. HEAD BOLT .....	10	REPLACES 0016908020
16	M3443200103	REAR DOOR .....	1	S/N 7500001 TO S/N 7500148
16	M3443200113	REAR DOOR .....	1	S/N 7500149~
17	M3443600104	WINDOW PLATE .....	1	
18	0037906000	HEX. NUT .....	10	S/N 7500001 TO S/N 7500034
18	020106050	HEX. NUT .....	10	REPLACES 0207306000 S/N 7500035~
18	0041206000	PLAIN WASHER .....	10	S/N 7500035~
18	0041206000	PLAIN WASHER .....	20	S/N 7500001 TO S/N 7500034
19	B9114000002	DOOR HANDLE ASSY.	1	
20	0027106016	MACHINE SCREW .....	4	REPLACES 0021806015
20	020106050	HEX. NUT .....	4	REPLACES 0030006000
21	M9110100204	HINGE	2	
22	M9116100004	WASHER	2	
23	011008020	HEX. HEAD BOLT .....	3	REPLACES 0016908020
24	M9310000004	BLIND PLUG	2	

# DCA-125SSJU2 — ENCLOSURE ASSY. (CONT.)

ENCLOSURE ASSY. (CONT.)

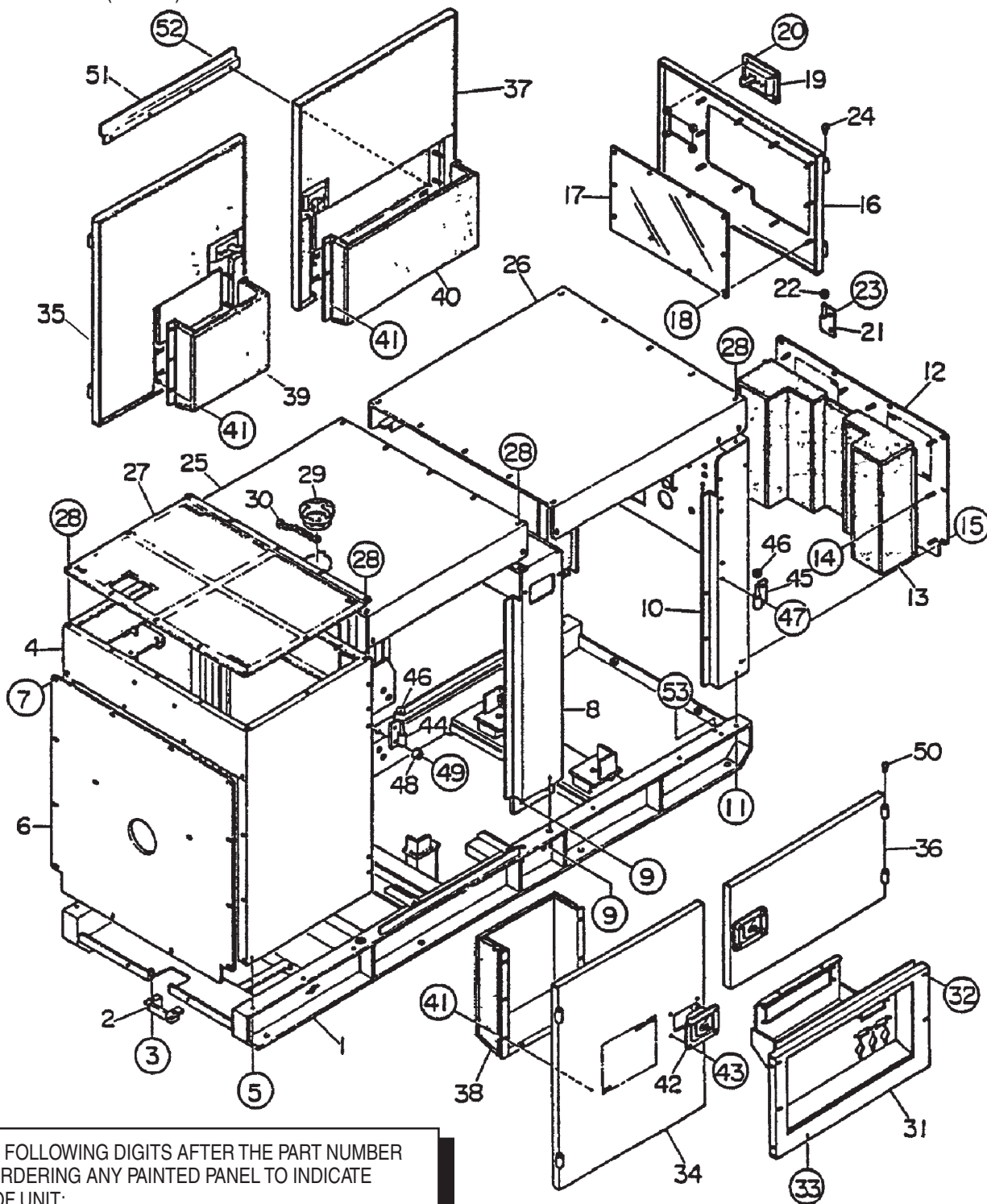

ADD THE FOLLOWING DIGITS AFTER THE PART NUMBER  
WHEN ORDERING ANY PAINTED PANEL TO INDICATE  
COLOR OF UNIT:

- |                 |                      |
|-----------------|----------------------|
| 1-ORANGE        | 5-BLACK              |
| 2-WHITE         | 6-CATERPILLAR YELLOW |
| 3-SPECTRUM GRAY | 7-CATO GOLD          |
| 4-SUNBELT GREEN |                      |

THE SERIAL NUMBER MAY BE REQUIRED.

## DCA-125SSJU2 — ENCLOSURE ASSY. (CONT.)

### ENCLOSURE ASSY. (CONT.)

<u>NO.</u>	<u>PART NO.</u>	<u>PART NAME</u>	<u>QTY.</u>	<u>REMARKS</u>
25	M3463100203	ROOF PANEL	1	
25	M3493500203	ACOUSTIC SHEET	1	
26	M3463200102	ROOF PANEL	1	
26	M3493500303	ACOUSTIC SHEET	1	
27	M3463500104	OVER COVER, FRONT FRAME	1	
28	011008020	HEX. HEAD BOLT .....	37	REPLACES 0016908020
29	M9310000103	ENCLOSURE CAP	1	
30	M1483600204	CHAIN ASSY.	1	
31	M3453200102	SPLASHER PANEL .....	1	S/N 7500001 TO S/N 7500034
31	M3453200102	SPLASHER PANEL .....	1	S/N 7500035 TO S/N7500307
31	M3453200122	SPLASHER PANEL .....	1	S/N 7500308 TO S/N7500507
31	M3453200132	SPLASHER PANEL .....	1	S/N7500508~
31	M3493401304	ACOUSTIC SHEET	1	S/N 7500001 TO S/N 7500034
31	M3493401314	ACOUSTIC SHEET	1	S/N 7500035~
32	011208060	HEX. HEAD BOLT .....	4	REPLACES 0016908055
33	012210025	HEX. HEAD BOLT .....	2	REPLACES 0016910025
34	M3453000703	SIDE DOOR	1	
34	M3493400704	ACOUSTIC KIT A.S. FRONT DOOR (L)	1	
35	M3453000603	SIDE DOOR	1	
35	M3453400804	ACOUSTIC SHEET	1	
36	M3453000503	SIDE DOOR (L)	1	
36	M3493401004	ACOUSTIC SHEET (L)	1	
37	M3453000403	SIDE DOOR (R)	1	
37	M3493401104	ACOUSTIC KIT A.S. REAR DOOR (R)	1	
38	M3453300303	DUCT (L)	1	
38	M3493400904	ACOUSTIC KIT A.S. FRONT DUCT (L)	1	
39	M3453300503	DUCT (R FRONT)	1	
39	M3493401404	ACOUSTIC KIT A.S. FRONT DOOR DUCT	1	
40	M3453300203	DUCT (R)	1	
40	M3493401204	ACOUSTIC KIT A.S. REAR DOOR DUCT	1	
41	0207006000	HEX. NUT	25	
42	B9114000002	DOOR HANDLE ASSY. ....	4	REPLACES M9113000002
43	0027106016	MACHINE SCREW .....	16	REPLACES 0021806015
43	020106050	HEX. NUT .....	16	REPLACES 0030006000
44	M9110100204	HINGE (L)	4	
45	M9110100304	HINGE (R)	4	
46	M9116100004	WASHER	8	
47	011008020	HEX. HEAD BOLT .....	9	REPLACES 0016908020
48	0601850097	DOOR STOPPER	8	
49	0027208025	MACHINE SCREW	8	
50	0845031504	BLIND PLUG .....	8	REPLACES M9310000004
51	M3453700004	DOOR BRACKET	1	
52	0016906015	HEX. HEAD BOLT	4	
53	016908020	HEX. HEAD BOLT	1	
53	0040508000	TOOTHED WASHER	1	

# DCA-125SSJU2 — RUBBER SEAL ASSY.

RUBBER SEAL ASSY.

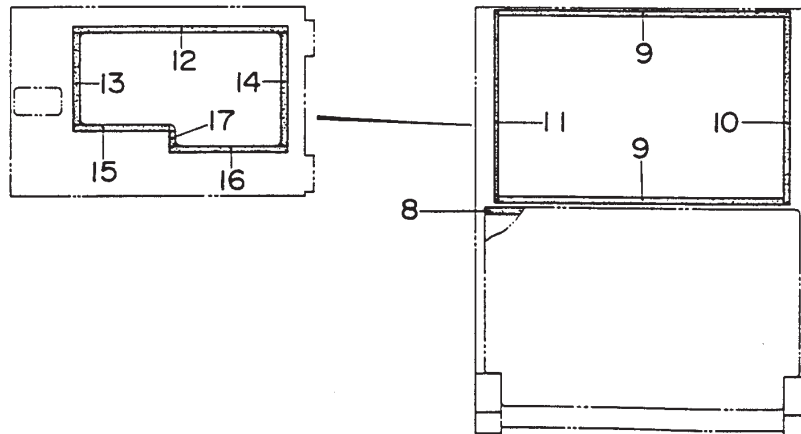
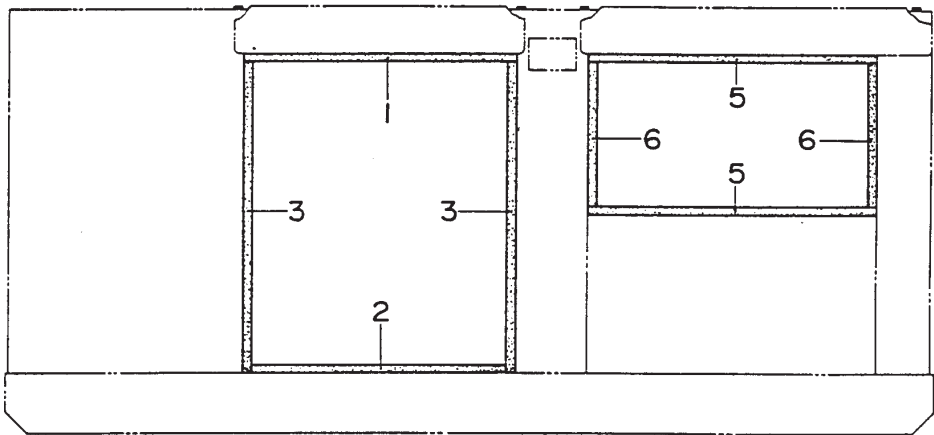
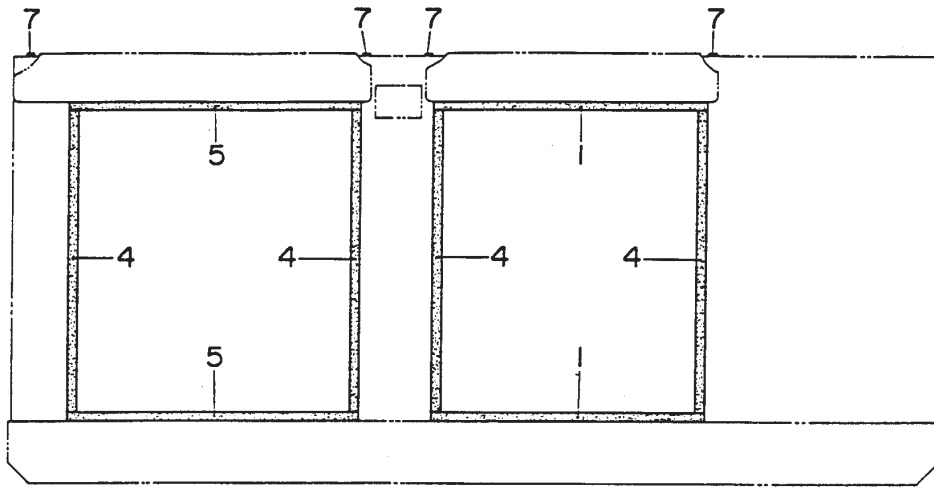

# DCA-125SSJU2 — RUBBER SEAL ASSY.

## RUBBER SEAL ASSY.

<u>NO.</u>	<u>PART NO.</u>	<u>PART NAME</u>	<u>QTY.</u>	<u>REMARKS</u>
1	0228900890	RUBBER SEAL	3	
2	0229200810	RUBBER SEAL	1	
3	0228901020	RUBBER SEAL	2	
4	0228900990	RUBBER SEAL	4	
5	0228900955	RUBBER SEAL	4	
6	0228900470	RUBBER SEAL	2	
7	0228900470	RUBBER SEAL	4	
8	0229201040	RUBBER SEAL	1	
9	0228800970	RUBBER SEAL	2	
10	0228800590	RUBBER SEAL	1	
11	0228800630	RUBBER SEAL	1	
12	0228100665	RUBBER SEAL	1	
13	0228100300	RUBBER SEAL	1	
14	0228100370	RUBBER SEAL	1	
15	0228100280	RUBBER SEAL	1	
16	0228100365	RUBBER SEAL	1	
17	0228100070	RUBBER SEAL	1	

FUEL TANK ASSY.

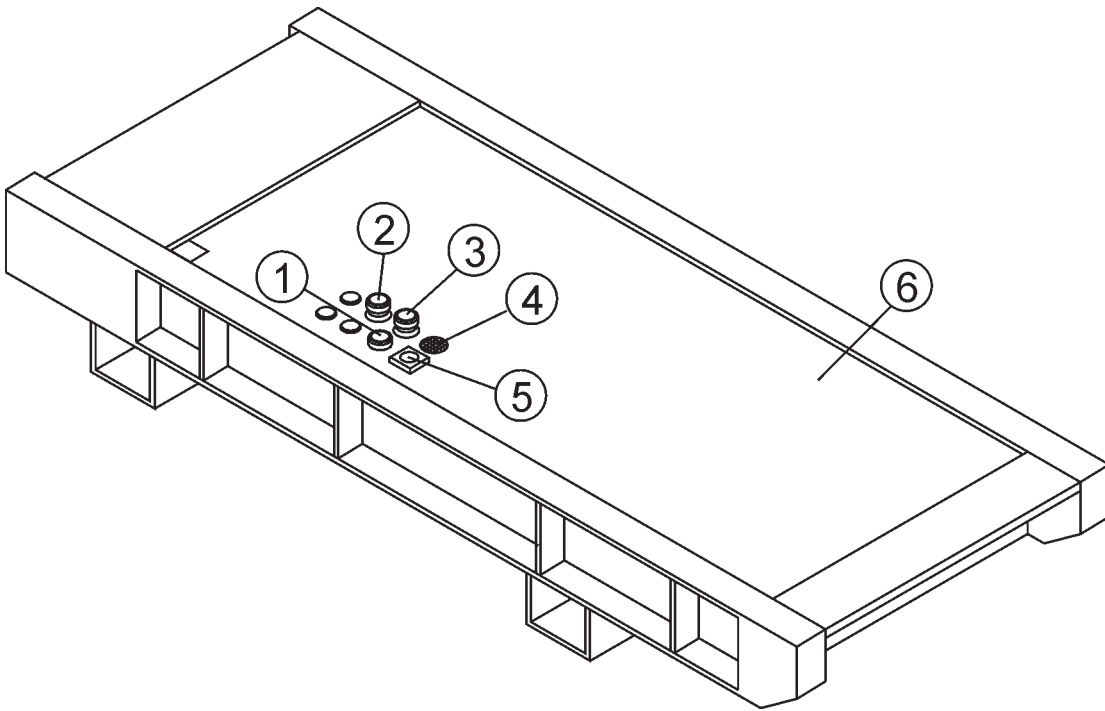

# DCA-125SSJU2 — FUEL TANK ASSY.

FUEL TANK ASSY.

<u>NO.</u>	<u>PART NO.</u>	<u>PART NAME</u>	<u>QTY.</u>	<u>REMARKS</u>
1	3000	CAP, FUEL	1	
2		REDUCER, 1/2 to 3/8 .....	1	OBTAIN LOCALLY
3		REDUCER, 1/2 to 3/8 .....	1	OBTAIN LOCALLY
4	2130	VENT, EMERGENCY	1	
5	9070	GUAGE, FUEL LEVEL	1	
6	SBT125-12H	TANK, FUEL, LESS FORK POCKETS .....	1	SEE NOTE BELOW

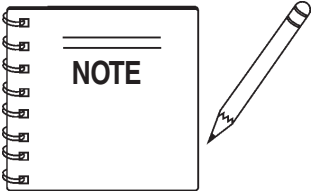

Fork pockets must be added to the above part number when ordering a replacement fuel tank.

# DCA-125SSJU2 — BATTERY CHARGER ASSY.

BATTERY CHARGER ASSY.

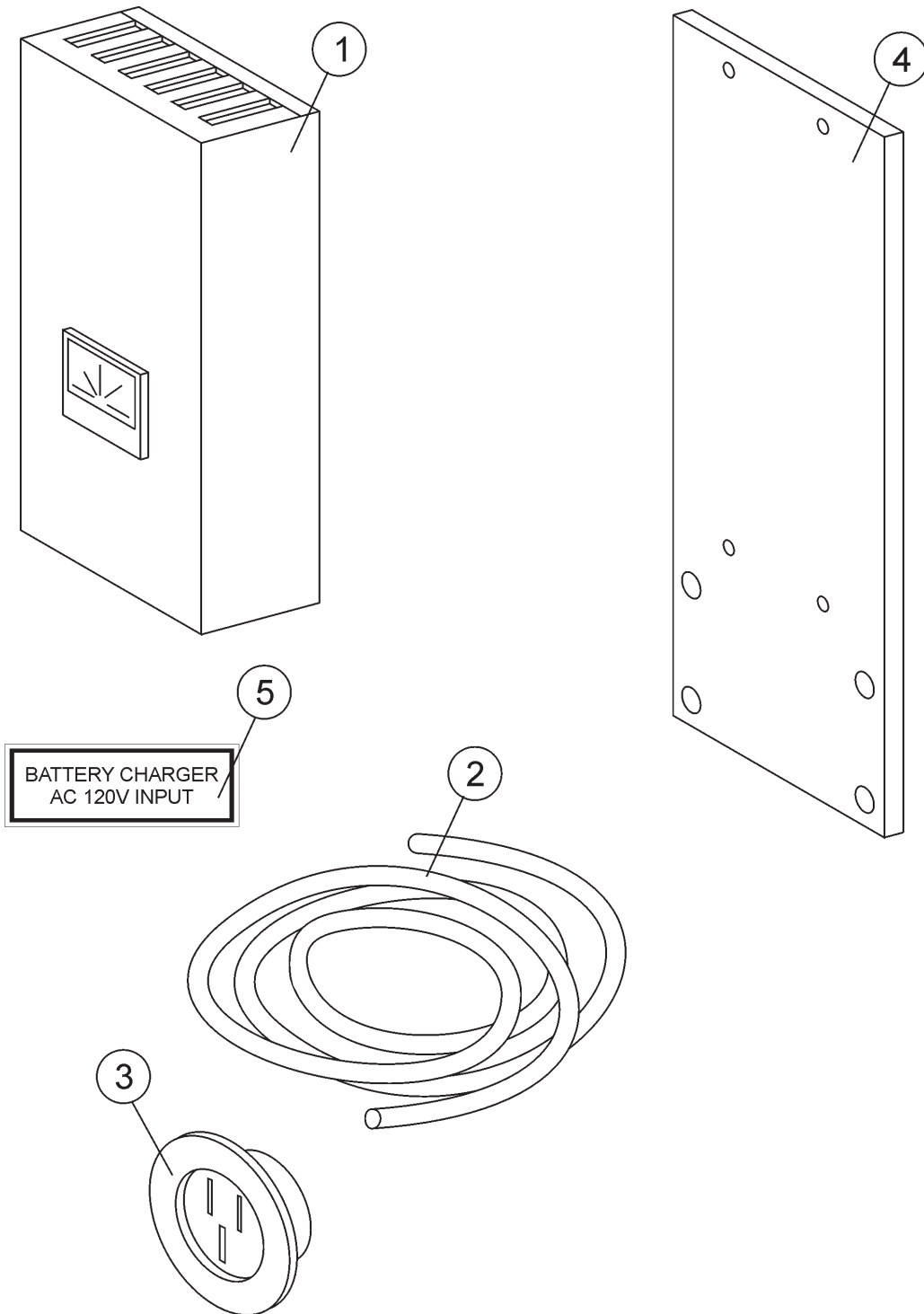

# DCA-125SSJU2 — BATTERY CHARGER ASSY.

## BATTERY CHARGER ASSY.

<u>NO.</u>	<u>PART NO.</u>	<u>PART NAME</u>	<u>QTY.</u>	<u>REMARKS</u>
1	LC125002	CHARGER, BATTERY 12V 3A	1	
2		CABLE, 16/3 x 3' .....	1.....	MAKE LOCALLY
3	HBL2578C	RECEPTICLE, 15A	1	
4	34530	BRACKET, MOUNTING	1	
5	M1940011014Q	DECAL, BATTERY CHARGER	1	

# DCA-125SSJU2 — CAMLOCK PANEL ASSY.

CAMLOCK PANEL ASSY.

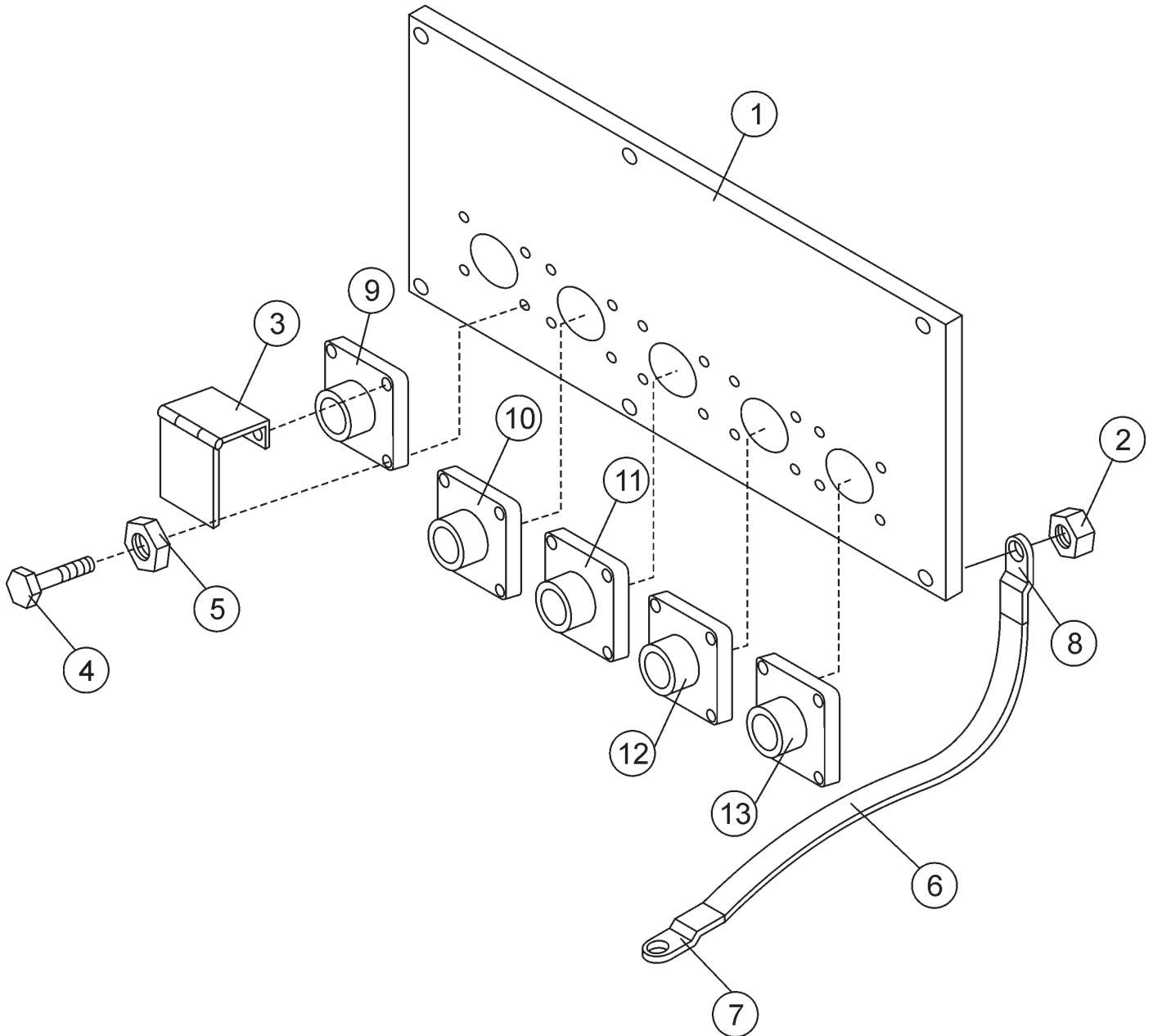

## DCA-125SSJU2 — CAMLOCK PANEL ASSY.

### CAMLOCK PANEL ASSY.

<u>NO.</u>	<u>PART NO.</u>	<u>PART NAME</u>	<u>QTY.</u>	<u>REMARKS</u>
1	CAM34553	CAM PANEL	1	
2		NUT, 1/2 x 13 .....	10 .....	OBTAIN LOCALLY
3	A100895-1	SNAP COVERS	5	
4		SCREW, 10/24 x 1-1/4" .....	20 .....	OBTAIN LOCALLY
5		NUTS, KEP 10/24 .....	20 .....	OBTAIN LOCALLY
6		CABLE, 20T x 15" .....	5 .....	MAKE LOCALLY
7		TERMINALS, EYE 20T x 1/2" .....	5 .....	OBTAIN LOCALLY
8		TERMINALS, EYE 20T x 3/8" .....	5 .....	OBTAIN LOCALLY
9	E1016-1602S	CAMLOCK, RED	1	
10	E1016-1600S	CAMLOCK, BLACK	1	
11	E1016-1612S	CAMLOCK, BLUE	1	
12	E1016-1605S	CAMLOCK, WHITE	1	
13	E1016-1604S	CAMLOCK, GREEN	1	

**PAYMENT TERMS**

Terms of payment for parts are net 10 days.

**FREIGHT POLICY**

All parts orders will be shipped collect or prepaid with the charges added to the invoice. All shipments are F.O.B. point of origin. Multiquip's responsibility ceases when a signed manifest has been obtained from the carrier, and any claim for shortage or damage must be settled between the consignee and the carrier.

**MINIMUM ORDER**

The minimum charge for orders from Multiquip is \$15.00 net. Customers will be asked for instructions regarding handling of orders not meeting this requirement.

**RETURNED GOODS POLICY**

Return shipments will be accepted and credit will be allowed, subject to the following provisions:

1. A Returned Material Authorization must be approved by Multiquip prior to shipment.
2. To obtain a Return Material Authorization, a list must be provided to Multiquip Parts Sales that defines item numbers, quantities, and descriptions of the items to be returned.
  - a. The parts numbers and descriptions must match the current parts price list.
  - b. The list must be typed or computer generated.
  - c. The list must state the reason(s) for the return.
  - d. The list must reference the sales order(s) or invoice(s) under which the items were originally purchased.
  - e. The list must include the name and phone number of the person requesting the RMA.
3. A copy of the Return Material Authorization must accompany the return shipment.
4. Freight is at the sender's expense. All parts must be returned freight prepaid to Multiquip's designated receiving point.

5. Parts must be in new and resalable condition, in the original Multiquip package (if any), and with Multiquip part numbers clearly marked.
6. The following items are not returnable:
  - a. Obsolete parts. (If an item is in the price book and shows as being replaced by another item, it is obsolete.)
  - b. Any parts with a limited shelf life (such as gaskets, seals, "O" rings, and other rubber parts) that were purchased more than six months prior to the return date.
  - c. Any line item with an extended dealer net price of less than \$5.00.
  - d. Special order items.
  - e. Electrical components.
  - f. Paint, chemicals, and lubricants.
  - g. Decals and paper products.
  - h. Items purchased in kits.
7. The sender will be notified of any material received that is not acceptable.
8. Such material will be held for five working days from notification, pending instructions. If a reply is not received within five days, the material will be returned to the sender at his expense.
9. Credit on returned parts will be issued at dealer net price at time of the original purchase, less a 15% restocking charge.
10. In cases where an item is accepted, for which the original purchase document can not be determined, the price will be based on the list price that was effective twelve months prior to the RMA date.
11. Credit issued will be applied to future purchases only.

**PRICING AND REBATES**

Prices are subject to change without prior notice. Price changes are effective on a specific date and all orders received on or after that date will be billed at the revised price.

Rebates for price declines and added charges for price increases will not be made for stock on hand at the time of any price change.

Multiquip reserves the right to quote and sell direct to Government agencies, and to Original Equipment Manufacturer accounts who use our products as integral parts of their own products.

**SPECIAL EXPEDITING SERVICE**

A \$35.00 surcharge will be added to the invoice for special handling including bus shipments, insured parcel post or in cases where Multiquip must personally deliver the parts to the carrier.

**LIMITATIONS OF SELLER'S LIABILITY**

Multiquip shall not be liable here under for damages in excess of the purchase price of the item with respect to which damages are claimed, and in no event shall Multiquip be liable for loss of profit or good will or for any other special, consequential or incidental damages.

**LIMITATION OF WARRANTIES**

No warranties, express or implied, are made in connection with the sale of parts or trade accessories nor as to any engine not manufactured by Multiquip. Such warranties made in connection with the sale of new, complete units are made exclusively by a statement of warranty packaged with such units, and Multiquip neither assumes nor authorizes any person to assume for it any other obligation or liability whatever in connection with the sale of its products. Apart from such written statement of warranty, there are no warranties, express, implied or statutory, which extend beyond the description of the products on the face hereof.



# OPERATION AND PARTS MANUAL

## **HERE'S HOW TO GET HELP**

*PLEASE HAVE THE MODEL AND SERIAL  
NUMBER ON-HAND WHEN CALLING*

### **PARTS DEPARTMENT**

*800-427-1244 or 310-537-3700*

*FAX: 800-672-7877 or 310-637-3284*

### **SERVICE DEPARTMENT**

*800-421-1244*

*FAX: 310- 537-4259*

### **TECHNICAL ASSISTANCE**

*800-478-1244*

*FAX: 310- 631-5032*

### **WARRANTY DEPARTMENT**

*888-661-4279, or 310-661-4279*

*FAX: 310- 537-1173*



#### **MULTIQUIP INC.**

18910 WILMINGTON AVE.  
CARSON, CALIFORNIA 90746  
310-537-3700  
800-421-1244  
FAX:310-537-3927

**E-mail:**[mq@multiquip.com](mailto:mq@multiquip.com) • **www:**[www.multiquip.com](http://www.multiquip.com)

#### **PARTS DEPARTMENT:**

800-427-1244  
FAX: 800-672-7877

#### **SERVICE DEPARTMENT:**

800-835-2551  
FAX:310-638-8046