

PARTS AND OPERATION MANUAL

MQ POWER DCA-125SSK WHISPERWATT™ GENERATOR

© COPYRIGHT 2000, MULTIQUIP INC.

Revision #2 (05/03/01)



MULTIQUIP INC.
18910 WILMINGTON AVE.
CARSON, CALIFORNIA 90746
310-537-3700
800-421-1244
FAX: 310-537-3927
E-mail: mq@multiquip.com • www.multiquip.com

PARTS DEPARTMENT:
800-427-1244
FAX: 800-672-7877

SERVICE DEPARTMENT:
800-835-2551
FAX: 310-638-8046



WARNING



CALIFORNIA--Proposition 65 Warning

Engine exhaust and some of its constituents are known to the State of California to cause cancer, birth defects and other reproductive harm.

HERE'S HOW TO GET HELP

*PLEASE HAVE THE MODEL AND SERIAL NUMBER
ON-HAND WHEN CALLING*

PARTS DEPARTMENT

800/427-1244 or 310/537-3700

FAX: 800/672-7877 or 310/637-3284

SERVICE DEPARTMENT

800/835-2551 or 310/537-3700

FAX: 310/638-8046

WARRANTY DEPARTMENT

800/835-2551 or 310/537-3700

FAX: 310/638-8046

MAIN

800/421-1244 or 310/537-3700

FAX: 310/537-3927

TABLE OF CONTENTS

Here's How To Get Help 3
Table Of Contents 4
Parts Ordering Procedures 5
Rules For Safe Operation 6-9
Operation And Safety Decals 10-11
Specifications 12
General Information 13

MQ Power DCA-125SSK AC Generator

Major Components 14
Dimensions (Top, Side And Rear) 15
Control Panel 16-17
Engine Operating Panel 18-19
Output Terminal Panel Overview 20-27
Installation 28-29
Pre-Setup 30-33
Load Application 34
Generator Start-Up Procedure (Manual) 35-37
Generator Start-Up Procedure (Auto) 38
Generator Shut-Down Procedure 39
Towing Safety Precautions 40
Trailer Safety Guidelines 41
Trailer Specifications 42-43
Trailer Braking System 44-45
Trailer Tires & Suspension 46-47
Trailer Wire Diagram 48
Trailer Electric Brakes Troubleshooting 49
Trailer Hydraulic Brakes Troubleshooting 50
Maintenance 52-53
Troubleshooting (Engine) 54-55
Troubleshooting (Generator/Engine) 56
Troubleshooting (MPEC) 57
Explanation Of Codes In Remarks Column 58
Suggested Spare Parts 59

Generator Assembly 60-63
Control Box Assembly 64-67
Engine Radiator Assembly 68-71
Engine Operating Panel Assembly 72-77
Battery Assembly 78-79
Muffler Assembly 80-81
Fuel Tank Assembly 82-83
Enclosure Assembly(up to S/N3402596) 84-87
Enclosure Assembly (from S/N3402597) 88-91
Enclosure (Rubber Seals) 92-93
Name Plate and Decals 94-95

Terms and Conditions Of Sale — Parts 96

NOTE

Specification and part number are subject to change without notice.

- Dealer account number
- Dealer name and address
- Shipping address (if different than billing address)
- Return fax number
- Applicable model number
- Quantity, part number and description of each part
- Specify preferred method of shipment:
 - UPS Ground
 - UPS Second Day or Third Day*
 - UPS Next Day*
 - Federal Express Priority One (please provide us with your Federal Express account number)*
 - Airborne Express*
 - Truck or parcel post

**Normally shipped the same day the order is received, if prior to 2PM west coast time.*

Earn Extra Discounts when you order by FAX!

All parts orders which include complete part numbers and are received by fax qualify for the following extra discounts:

<u>Number of line items ordered</u>	<u>Additional Discount</u>
1-9 items	3%
10+ items**	5%

Get special freight allowances when you order 10 or more line items via FAX! **

- UPS Ground Service at no charge for freight
- PS Third Day Service at one-half of actual freight cost

No other allowances on freight shipped by any other carrier.

**Common nuts, bolts and washers (all items under \$1.00 list price) do not count towards the 10+ line items.

DISCOUNTS ARE SUBJECT TO CHANGE

Fax order discount and UPS special programs revised June 1, 1995

**Extra Fax Discount
for Domestic USA
Dealers Only**

**Up to 5%
extra savings!**

**UPS
Special**
For faxed orders only

**Now! Direct TOLL-FREE access
to our Parts Department!**

Toll-free nationwide:

800-421-1244

Toll-free FAX:

800/6-PARTS-7 • 800-672-7877

RULES FOR SAFE OPERATION

CAUTION:



Failure to follow instructions in this manual may lead to serious injury or even death! This equipment is to be operated by trained and qualified personnel only! This equipment is for industrial use only.

The following safety guidelines should always be used when operating the DCA-125SSK portable generator:

GENERAL SAFETY

- **DO NOT** operate or service this equipment before reading this entire manual.



- This equipment should not be operated by persons under 18 years of age.

- **NEVER** operate this equipment without proper protective clothing, shatterproof glasses, steel-toed boots and other protective devices required by the job.



- **NEVER** operate this equipment when not feeling well due to fatigue, illness or taking medicine.



- **NEVER** operate this equipment under the influence of drugs or alcohol.



- **NEVER** use accessories or attachments, which are not recommended by MQ Power for this equipment. Damage to the equipment and/or injury to user may result.

- Manufacture does not assume responsibility for any accident due to equipment modifications.

- Whenever necessary, replace nameplate, operation and safety decals when they become difficult read.

- Always check the machine for loosened threads or bolts before starting.

- **NEVER** touch the hot exhaust manifold, muffler or cylinder. Allow these parts to cool before servicing engine or generator.



- **High Temperatures** – Allow the engine to cool before adding fuel or performing service and maintenance functions. Contact with hot components can cause serious burns.

- The engine of this generator requires an adequate free flow of cooling air. Never operate the generator in any enclosed or narrow area where free flow of the air is restricted. If the air flow is restricted it will cause serious damage to the generator or engine and may cause injury to people. Remember the generator engine gives off **DEADLY** carbon monoxide gas.

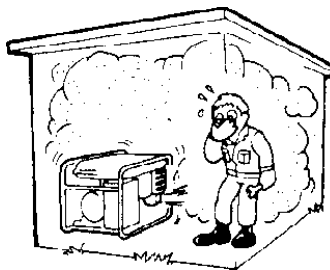

CAUTION:



Always refuel in a well-ventilated area, away from sparks and open flames.



- Always use extreme caution when working with **flammable** liquids. When refueling, **stop the engine** and allow it to cool. **DO NOT** smoke around or near the machine. Fire or explosion could result from fuel vapors, or if fuel is spilled on a hot engine.

- **NEVER** operate the generator in an explosive atmosphere or near combustible materials. An explosion or fire could result causing severe *bodily harm or even death*.

- Topping-off to filler port is dangerous, as it tends to spill fuel.

RULES FOR SAFE OPERATION

CAUTION:

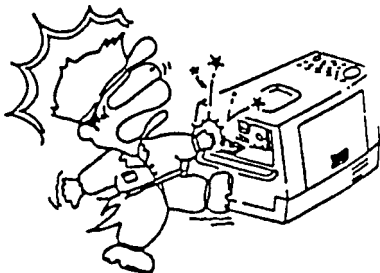

■ **DO NOT** touch output terminals during operation. This is extremely dangerous when your hands are **wet**. Always stop the machine when contact with the output terminals is required.

CAUTION:

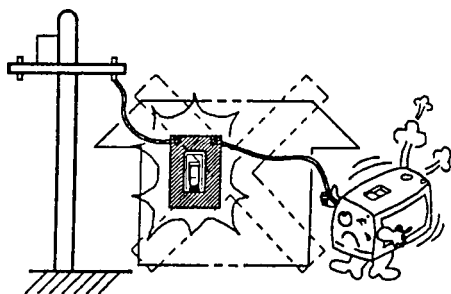

■ **Backfeed to a utility system can cause electrocution and/or property damage. Do not connect to any building's electrical system except through an approved device or after building main switch is opened.**

CAUTION:



■ **Never** use damaged or worn cables when connecting power tools or equipment to the generator. Make sure the power connecting cables are securely connected to the generator's output terminals. Insufficient tightening of the terminal connections may cause damage to the generator and electrical shock.

CAUTION:



DO NOT touch or open any of the below mentioned components while the generator is running. Always allow sufficient time for the engine and generator to cool before performing maintenance.

Radiator

1. **Radiator Cap** - Removing the radiator cap while the engine is hot will result in boiling water to gush out of the radiator, therefore causing severe scalding to any persons in the general area of the generator.

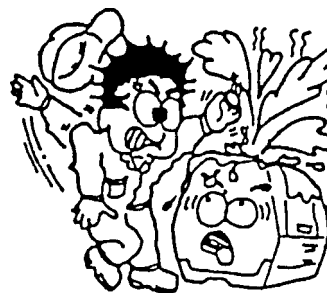

2. **Coolant Drain Plug** - Removing the coolant drain plug while the engine is hot will result in hot coolant to gush out of the coolant drain plug, therefore causing severe scalding to any persons in the general area of the generator.
3. **Engine Oil Drain Plug** - Removing the engine oil drain plug while the engine is hot will result in hot oil to gush out of the oil drain plug, therefore causing severe scalding to any persons in the general area of the generator.

Battery

CAUTION:



Never over fill the battery with water above the upper limit.

The battery contains acids that can cause injury to the eyes and skin. To avoid eye irritation, always wear safety glasses. Use well insulated gloves when picking up the battery. Use the following guidelines when handling the battery:

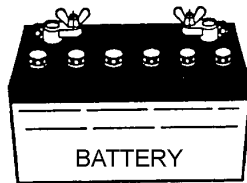

1. **DO NOT** drop the battery. There is the possibility the battery may explode.
 2. **DO NOT** expose the battery to open flames, sparks, cigarettes etc. The battery contains combustible gases and liquids. If these gases and liquids come in contact with a flame or spark, an explosion could occur.
 3. Always keep the battery charged. If the battery is not charged, a buildup of combustible gas will occur.
 4. Always keep battery charging and booster cables in good working condition. Repair or replace all worn cables.
 5. Always recharge the battery in an open air environment, to avoid risk of a dangerous concentration of combustible gases.
 6. In case the battery liquid (dilute sulfuric acid) comes in contact with **clothing or skin**, rinse skin or clothing immediately with plenty of water.
 7. In case the battery liquid (dilute sulfuric acid) comes in contact with your **eyes**, rinse eyes immediately with plenty of water, then contact the nearest doctor or hospital, and seek medical attention.
- **NEVER** Run engine without an air filter. Severe engine damage may occur.
 - Always service air cleaner frequently to prevent carburetor malfunction.
 - Always disconnect the battery before performing service on the generator.
 - Always be sure the operator is familiar with proper safety precautions and operations techniques before using generator.
 - Always store equipment properly when not in use. Equipment should be stored in a clean, dry location out of the reach of children.
 - **DO NOT** leave the generator running in the manual mode unattended.
 - **DO NOT** allow unauthorized people to operate this equipment.
 - Always read, understand, and follow procedures in Operator's Manual before attempting to operate equipment.
 - Refer to the *Komatsu Engine Owner's Manual* for engine technical questions or information.

Loading and Unloading (Crane)

- Before lifting, make sure the generator's lifting hook is secure and that there is no apparent damage to the generator itself (loose screws, nuts and bolts). If any part is loose or damaged, please take corrective action before lifting.
- Always drain fuel prior to lifting.
- Always make sure crane or lifting device has been properly secured to the hook of guard frame on generator.
- **NEVER** lift the machine while the engine is running.
- Use adequate lifting cable (wire or rope) of sufficient strength.
- When lifting the generator, always use the balanced center-point suspension hook and lift straight upwards.
- **NEVER** allow any person or animal to stand underneath the machine while lifting.
- When loading the generator on a truck, be sure to use the front and back frame bars as a means to secure the generator during transport.

RULES FOR SAFE OPERATION

Transporting

- Always shutdown engine before transporting.
- Tighten fuel tank cap securely.
- Drain fuel when transporting generator over long distances or bad roads.
- Always tie-down the generator during transportation by securing the generator.
- If generator is mounted on a trailer, make sure trailer complies with all local and state safety transportation laws. See page 40 (Figure 64) for basic towing procedures.

Emergencies

- Always know the location of the nearest ***fire extinguisher*** and ***first aid kit***. Know the location of the nearest telephone. Also know the phone numbers of the nearest ***ambulance***, ***doctor*** and ***fire department***.

Maintenance Safety

- **NEVER** lubricate components or attempt service on a running generator.
- Always allow the engine proper amount of time to cool before servicing.
- Keep the generator in proper running condition.
- Fix damage to the generator immediately and always replace broken parts.
- Dispose of hazardous waste properly. Examples of potentially hazardous waste are used motor oil, coolant, fuel, and fuel filters.
- **DO NOT** use plastic containers to dispose of hazardous waste.
- **DO NOT** pour waste, oil, coolant or fuel directly onto the ground, down a drain or into any water source.

OPERATION AND SAFETY DECALS

Machine Safety Decals

The DCA-125SSK generator is equipped with a number of safety decals. These decals are provided for operator safety and maintenance information. The illustration below and on the preceding page shows these decals as they appear on the machine. Should any of these decals become unreadable, replacements can be obtained from your dealer.

OPERATING PROCEDURES

Manual Starting

1. Check the engine oil, coolant, and fuel levels. Replenish if necessary.
2. Place all Generator Circuit Breakers in the "OFF" position and close all doors.
3. Check that the Voltage select switch (or the Voltage change-over board) is present at desired voltage.
4. In case of generator having multiple voltage ratings.
5. Set the Engine speed switch to the "LOW" position.
6. Turn the Auto-Off/Reset-Manual switch to the "Manual" position to start the engine. If the engine fails to start in the specified number of attempts, the overcrank lamp will indicate and the Auto-Off/Reset-Manual switch must be returned to the "Off/Reset" position before proceeding.
7. When the engine is ready for starting during cold weather operating conditions, push the intake heater button for approximately 30 seconds. Start engine using the Auto-Off/Reset-Manual switch to the "Manual" position. As soon as the engine starts, release the button.
8. If the engine still does not start, utilize the water heater until water is warm. (If additional water heater is supplied).
9. After starting, allow the engine to run for 1 or 2 minutes to warm-up. At temperatures below freezing, this time period must be extended to 2 to 4 minutes.
10. When the engine starts, immediately check for abnormal noise, vibration, fluid leakage or any indicators of a problem. Check the control panel gauges. If all is normal, let the engine remain at the "Low" position for a short time, depending on the ambient conditions, warm up.
11. After sufficient warm-up time has elapsed, set the Engine speed switch to the "High" position and the unit is ready for operation.
12. Check the No-Load speed as shown in the table below. (50Hz operation—Approx 50 Hz (1500Rpm)
13. Adjust the Voltage Regulator to the specified voltage.

M35200010

P/N M3552000103

SAFETY INSTRUCTIONS

Improper operation of this machine can cause severe injury or death.

- Read the instruction manual carefully before operating or servicing.

This machine should only be operated by a person with sufficient knowledge and skill to ensure safe operation.

High voltage circuits are located inside the output terminal cover and control panel.

- Close the cover and control panel before operating.

Moving parts and hot surfaces are contained within the enclosure.

- Close all doors and lock them before operating.

M92010030

P/N M9520100304

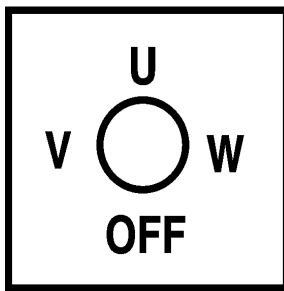

P/N M9520000104

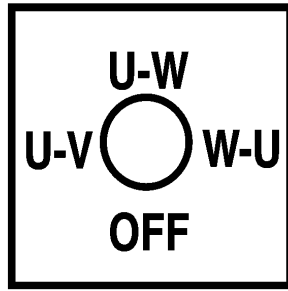

P/N M9520000204

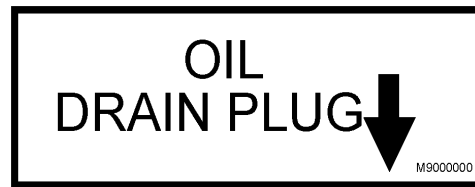

P/N M950000004



P/N M9510200002

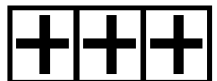

P/N M9500300104



P/N M9500300004

OVER CURRENT RELAY

If it is impossible to reset the CIRCUIT BREAKER, open the control panel and push the RESET BUTTON as below.

M92020010

P/N M9520200104

DIESEL FUEL

M90050000

P/N M9500500004



P/N M9500500104

WATER • OIL CHECK AND FILL DAILY

M90300010

P/N M9503000103

OPERATION AND SAFETY DECALS

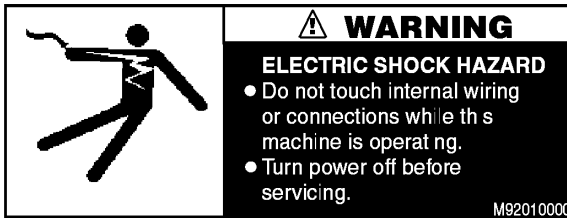

P/N M9520100004



P/N M9520100401

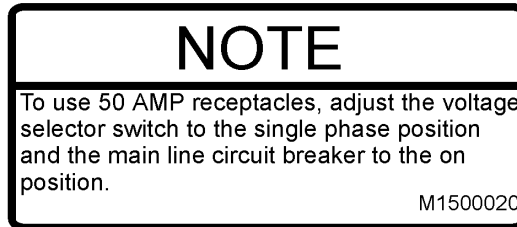

P/N M1550000204

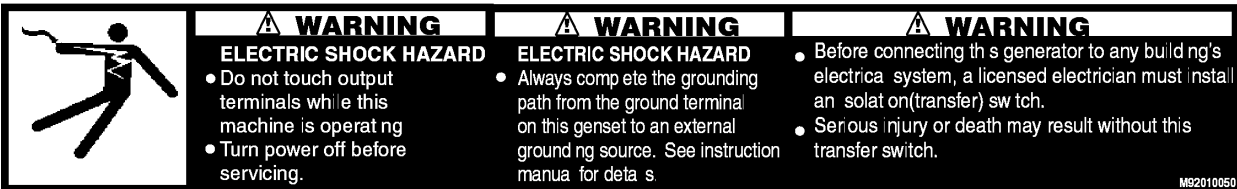

P/N M9520100503

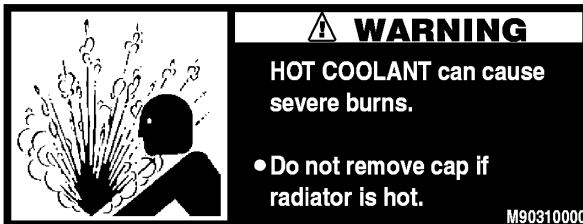

P/N M9503100004

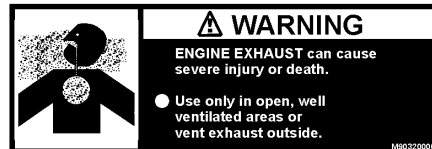

P/N M9503200004



P/N M9520100204

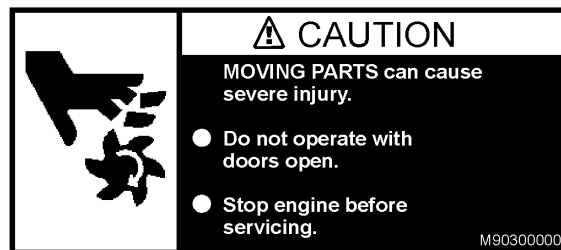

P/N M9503000004

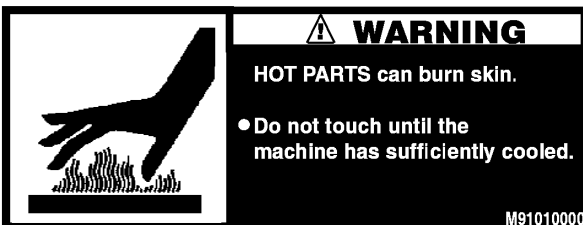

P/N M9510100004

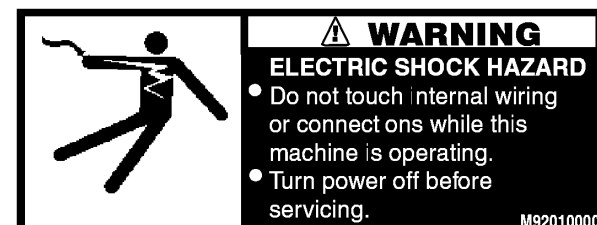

P/N M9520100004

DCA-125SSK — SPECIFICATIONS

Table 1. Specifications		
Generator Specifications		
Model	DCA-150SSKII	
Type	Revolving field, self ventilated, open protected type synchronous generator	
Armature Connection	Star with Neutral	Zig Zag
Phase	3	Single
Standby Output	165 KVA (132 KW)	96KW
Prime Output	150 KVA (120 KW)	87KW
Voltage	240V or 480V	240V
Frequency	60 Hz	
Speed	1800 rpm	
Power Factor	0.8	1
Aux. AC Power	Single Phase, 60 Hz	
Voltage	120 V	
Output	4.8 KW (2.4 KW x 2)	
Engine Specifications		
Model	KOMATSU S6D108E-2	
Type	4-cycle, water-cooled, direct injection, turbo-charged	
No. of Cylinders	6 cylinders	
Bore x Stroke	4.25 in. x 5.11 in. (108 mm x 130 mm)	
Rated Output	180HP/1800 rpm	
Displacement	436 cu. in. (7150 cc)	
Starting	Electric	
Coolant Capacity	7.4 gal. (28 liters)	
Lube Oil Capacity	6.6 gal. (25 liters)	
Fuel Consumption	9.2 gal. (34.8L)/hr at full load	6.9 gal. (26.1L)/hr at 3/4 load
	4.8 gal. (18.2L)/hr at 1/2 load	3.2 gal. (12.1L)/hr at 1/4 load
Battery	12V- 120AHx2	
Fuel	#2 Diesel Fuel	

DCA-125SSK FAMILIARIZATION

Generator

The MQ Power Model DCA-125SSK is a 120 kW *generator* that is designed as a high quality portable (requires a trailer for transport) power source for telecom sites, lighting facilities, power tools, submersible pumps and other industrial and construction machinery.

Engine Control Panel

The "Engine Control Panel" is provided with the following:

- Tachometer
- Water Temperature Gauge
- Oil Pressure Gauge
- Charging Ammeter Gauge
- Engine Warning Lamp Module
- Engine Throttle Lever
- Pre-Heat Button
- Pre-Heat Lamp

Generator Control Panel

The "Generator Control Panel" is provided with the following:

- Output Voltage Adjustment Knob
- Frequency Meter (Hz)
- AC Ammeter (Amps)
- AC Voltmeter (Volts)
- Ammeter Change-Over Switch
- Voltmeter Change-Over Switch
- Panel Light
- Panel Light Switch
- MPEC Module

Output Terminal Panel

The "Output Terminal Panel" is provided with the following:

- Three 240/139V output receptacles, 50 amp
- Two 120V input receptacles, 20 amp
- 3 Load Circuit Breakers 265V @65 amps
- 2 Load GFCI Circuit Breakers 265V@ 20amps

Control Box

The "Control Box" is provided with the following:

- Main Circuit Breaker 400 amps
- Over-Current Relay

Microprocessor Controlled Alarm System

The DCA-125SSK generator is equipped with various alarms and LED status indicators. These alarms and status indicators are provided to add safety to the generator when operating under normal conditions. The DCA-125SSK generator is designed to shutdown in the event of low oil, high coolant temperature, low battery and other operation conditions that may cause severe damage to the generator.

Open Delta Excitation System

The DCA-125SSK generator is equipped with the state of the art "*Open-Delta*" excitation system. The open delta system consist of an electrically independent winding wound among stationary windings of the AC output section.

There are four leads: A, B, C and D. During light loads, the power to the *Automatic Voltage Regulator* (AVR) is supplied from the leads parallel connections of B&C. When loads increase, the AVR switches and accepts power from leads A&D. The output of leads A&D increase proportionally with load. This of adding the voltages to each phase provides better voltage response during heavy loads.

The connections of the AVR to the AC output windings are for sensing only. No power is required from these windings.

The open-delta design provides virtually unlimited excitation current, offering maximum motor starting capabilities. The excitation does not have a "*fixed ceiling*" and responds according the demands of the required load.

Engine

The **DCA-125SSK** is powered by a 4-cycle water cooled, turbocharged KOMATSU Model S6D108E-2 *diesel* engine. This engine is designed to meet every performance requirement for the generator. Reference Table 1, page 13 for engine specifications.

In keeping with MQ Power's policy of constantly improving its products, the specifications quoted herein are subject to change without prior notice.

The basic controls and indicators for the DCA-125SSK generator are addressed on the following pages.

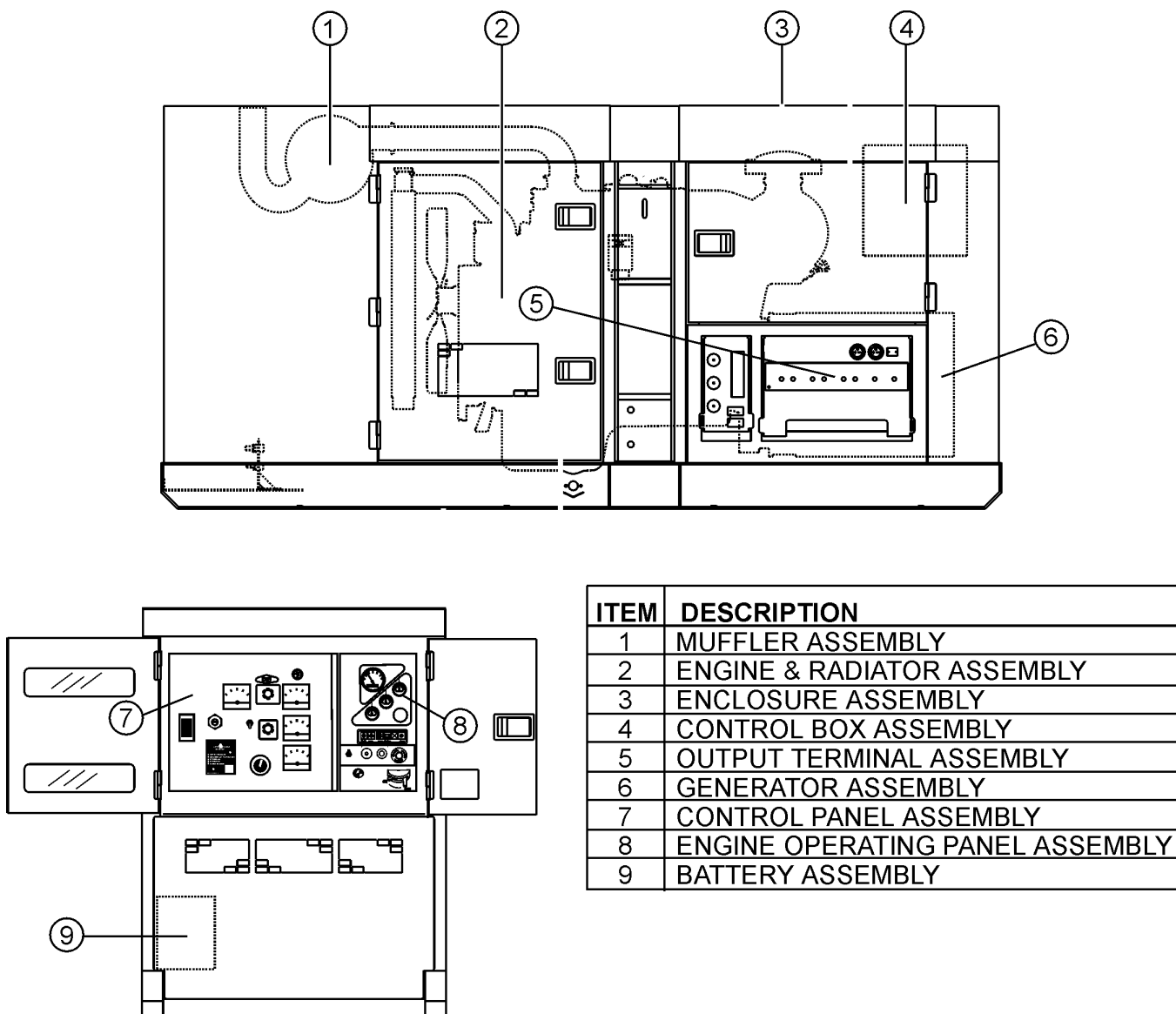

Figure 1. Major Components

DCA-125SSK — DIMENSIONS (TOP, SIDE, AND REAR)

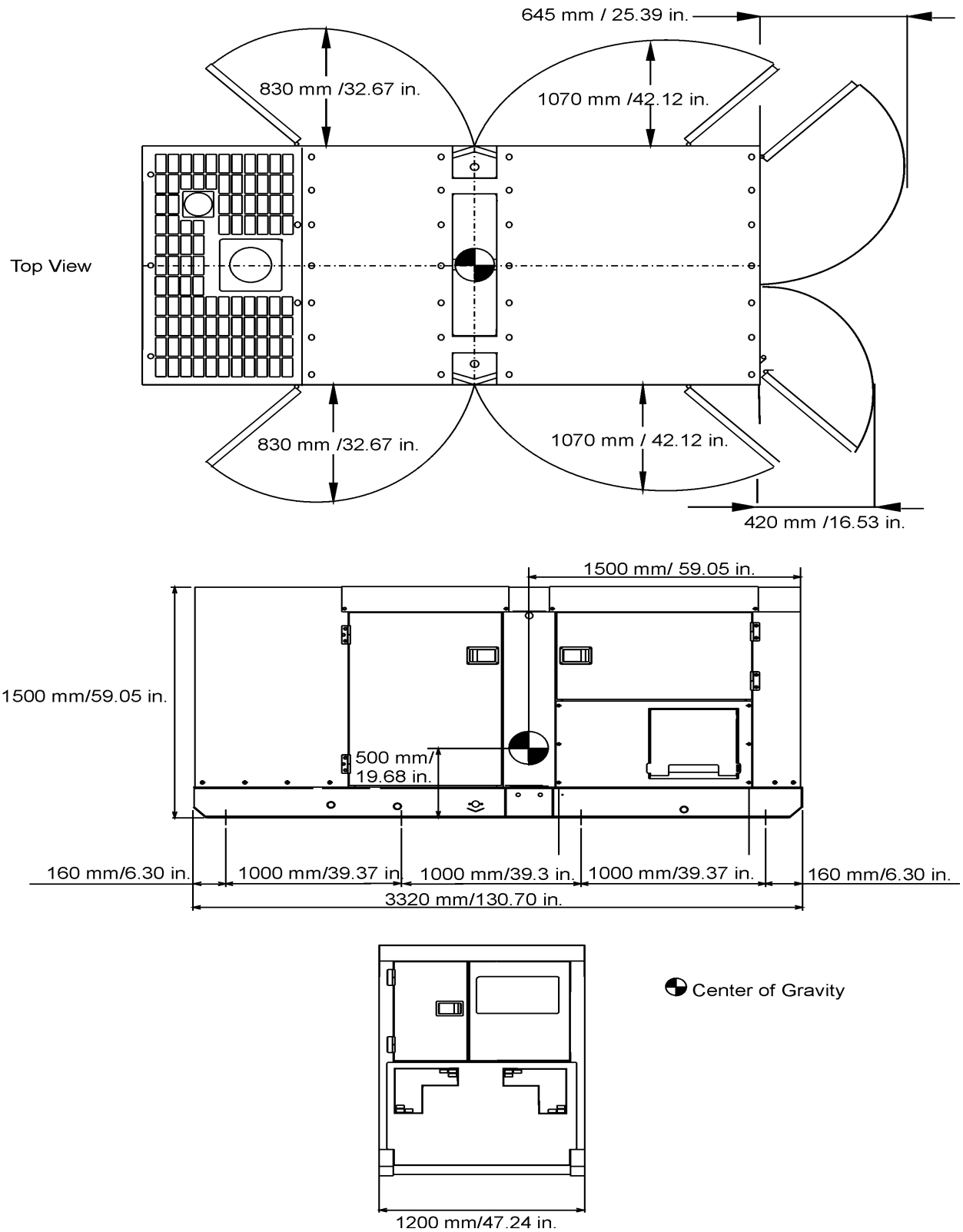
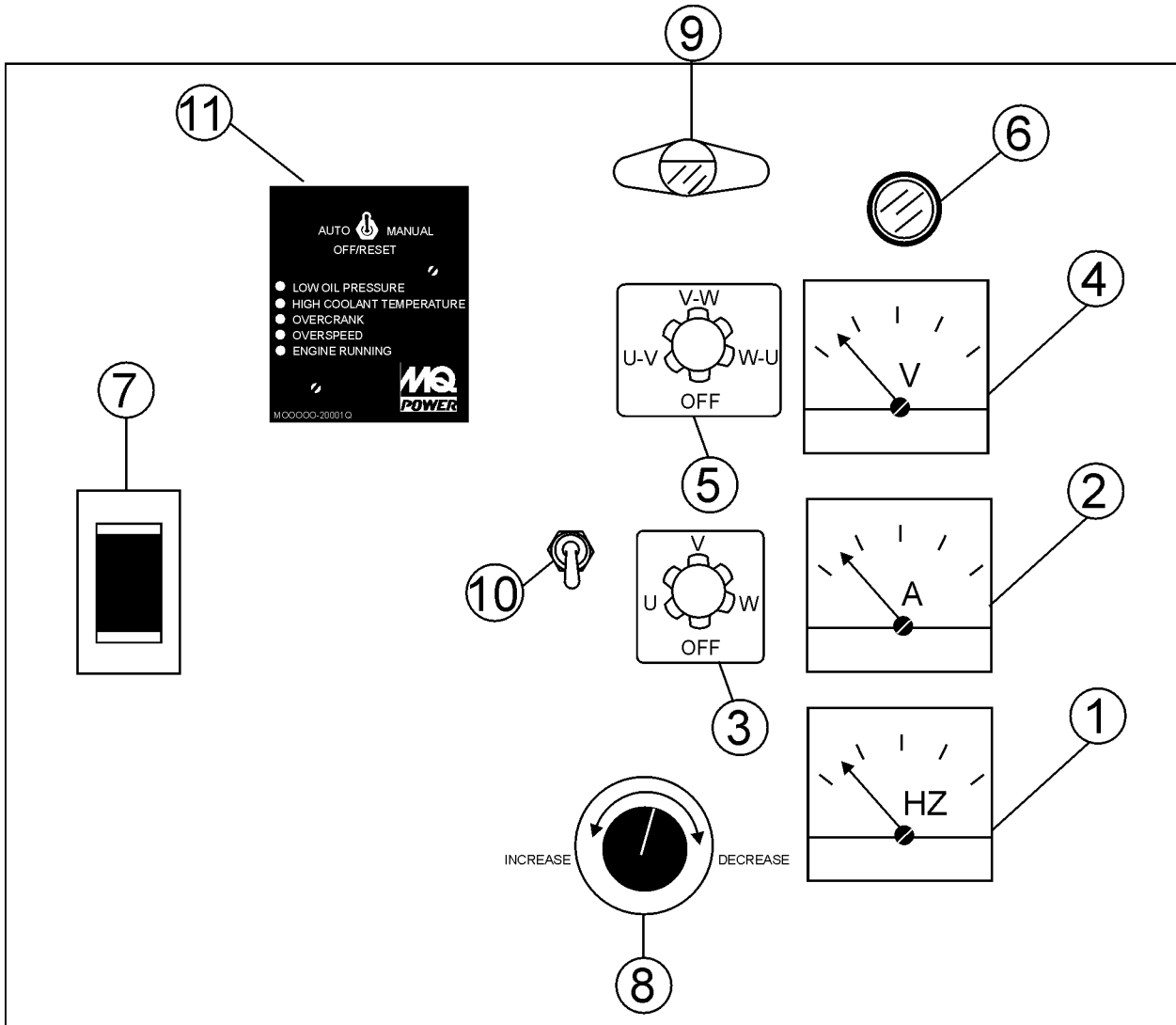

Figure 2. Dimensions



NO	DESCRIPTION
1	FREQUENCY METER
2	AC AMMETER
3	AMMETER CHANGE-OVER SWITCH
4	AC VOLTMETER
5	VOLTMETER CHANGE-OVER SWITCH
6	PILOT LAMP
7	CIRCUIT BREAKER
8	VOLTAGE REGULATOR
9	PANEL LIGHT
10	PANEL LIGHT SWITCH
11	MICROPROCESSOR ENGINE CONTROL

Figure 3. Control Panel

The definitions below describe the controls and functions of the DCA-125SSK " **Control Panel** "(Figure 3).

1. **Frequency Meter** – Indicates the output frequency in hertz (Hz). Normally 60 Hz ±1 Hz .
2. **AC Ammeter** – Indicates the amount of current the load is drawing from the generator.
3. **Ammeter Change-Over Switch** – This switch allows the AC ammeter to indicate the current flowing to the load connected to any phase of the output terminals, or to be switched off.
4. **AC Voltmeter** – Indicates the single phase output voltage present at the UVW terminals.
5. **Voltmeter Change-Over Switch** – This switch allows the AC voltmeter to indicate phase to phase voltage between any two phases of the output terminals or to be switched off.
6. **Pilot Lamp** – Indicates that the generator is working properly.
7. **Main Circuit Breaker** – This three-pole, 600 amp main breaker is provided to protect the UVW voltage output terminals from overload.
8. **Voltage Regulator Control** – Allows manual adjustment of the generator's output voltage
9. **Panel Light** – Normally used in dark areas or at night time. When activated, panel lights will illuminate. When the generator is not in use be sure to turn the panel light switch to the OFF position.
10. **Panel Light Switch** – When activated will turn on control panel light.
11. **MPEC – Microprocessor Engine Control Module** – (MPEC) has a vertical row of status LED's (Figure 4), that when lit, indicate that a engine malfunction (fault), has been detected. When a fault has been detected the MPEC will evaluate the fault and all major faults will shutdown the generator.

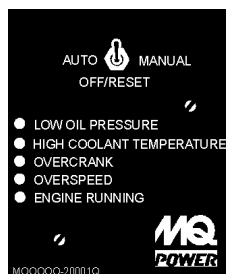

Figure 4. MPEC Module

During **cranking cycle** , The MPEC will attempt to crank the engine for 10 seconds before disengaging. If the engine does not engage (start) by the third attempt, the engine will be shutdown by the MPEC's " Over Crank Protection" mode. If the engine engages at a speed (RPM's) that is not safe, the MPEC will shutdown the engine by initializing the "Over Speed Protection" mode.

Also the MPEC will shutdown the generator in the event of low oil pressure, high coolant temperature, low coolant level, and loss of magnetic pickup. These conditions can be observed by monitoring the LED status indicators on the front of the MPEC module.

A. Off/Manual/Auto Switch – This switch controls the running of the generator. If this switch is left in the "OFF" position, the generator will not run. When this switch is set to the **manual** position, the generator will start immediately.

If the generator is to be connected to a building's AC power source via a transfer switch (isolation), place the switch in the **auto** position. In this position the generator will monitor the AC line output from the building's power source.

B. Low Oil Pressure – Indicates the engine pressure has fallen below 15 psi. The oil pressure is detected using variable resistive values from the oil pressure sending unit. This is considered a **major** fault.

C. High Coolant Temperature – Indicates the engine temperature has exceeded 215°F. The engine temperature is detected using variable resistive values from the temperature sending unit. This is considered a **major** fault.

D. Overcrank Shutdown – Indicates the unit has attempted to be started a pre- programmed number of times, and has failed to start. The number of cycles and duration are programmable. It is preset at 3 cycles with a 10 second duration. This is considered a **major** fault.

E. Overspeed Shutdown – Indicates that the engine is running at an unsafe speed. This is considered a **major** fault.

F. Engine Running – Indicates that engine is running at a safe operating speed.

DCA-125SSK — ENGINE OPERATING PANEL

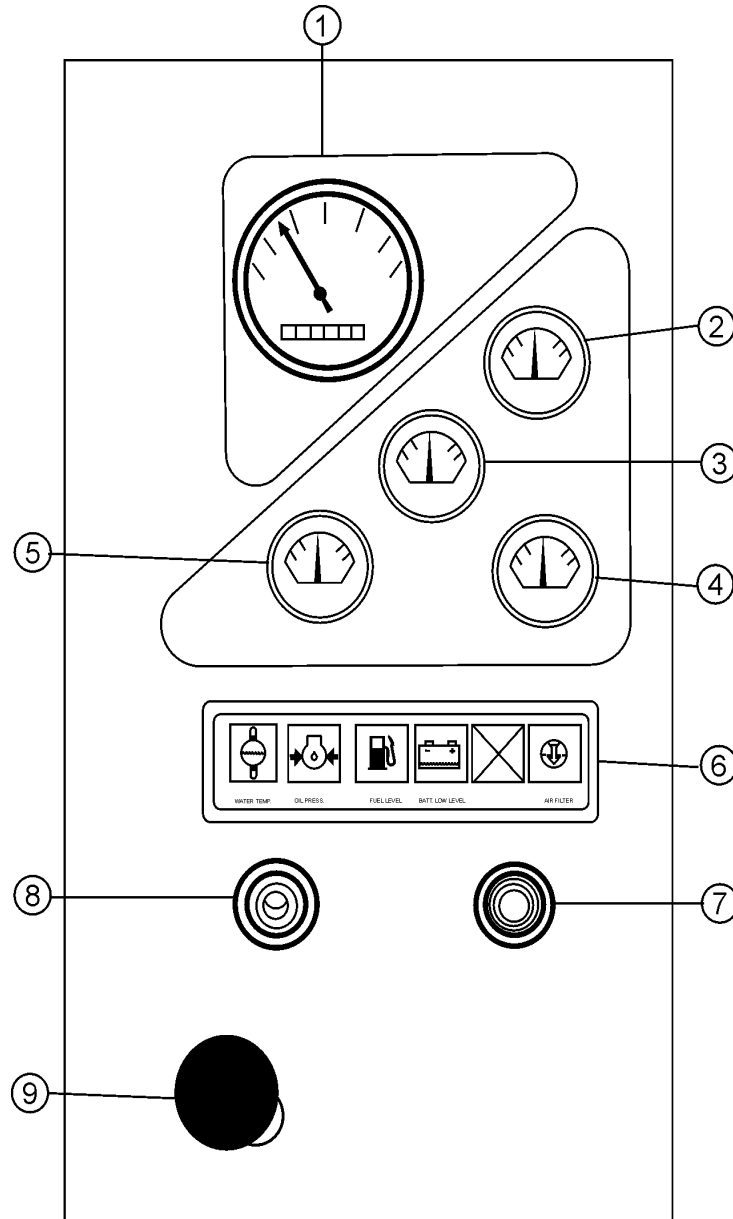

NO	DESCRIPTION
1	TACHOMETER
2	WATER TEMPERATURE GAUGE
3	OIL PRESSURE GAUGE
4	CHARGING AMMETER
5	FUEL GAUGE
6	WARNING LAMP MONITOR
7	PRE-HEAT BUTTON
8	PRE-HEAT LAMP
9	ENGINE THROTTLE LEVER

Figure 5. Engine Operating Panel

DCA-125SSK — ENGINE OPERATING PANEL

The definitions below describe the controls and functions of the DCA-125SSK " **Engine Operating Panel** "(Figure 5).

1. **Tachometer** – Indicates engine speed in RPM's for 60 Hz operation. This meter should indicate 1800 RPM's when the rated load is applied. In addition a built in hour meter will record the number of operational hours that the generator has been in use.
2. **Water Temperature Gauge** – During normal operation this gauge be should read in the "GREEN" zone.
3. **Oil Pressure Gauge** – During normal operation this gauge be should read in the "GREEN" zone. When starting the generator the oil pressure mar read a little bit higher, but after the engine warms up the oil pressure should return to the green zone.
4. **Charging Ammeter Gauge** – Indicates the current being supplied by the engine's alternator which provides current for generator's control circuits and battery charging system.
5. **Fuel Gauge** - Indicates amount of diesel fuel available.
6. **Engine Warning Display Module** – This module display's the following engine failures:

A. **Overheat Lamp** – This lamp goes ON when the cooling water temperature rises abnormally. If the lamp goes ON during normal operation of the generator, the emergency shutdown device will stop the engine automatically.

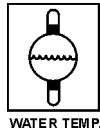

B. **Low Oil Pressure Lamp** – During normal operation of the generator this lamp should remain OFF. When the Auto-OFF/Reset-Manual switch is set to the "Manual" position to start the engine, the lamp will be lit. After the oil pressure rises after start-up the lamp will go OFF. If this lamp is ever lit (ON) during normal operation of the generator, the emergency shutdown device will stop the engine automatically.



C. **Low Fuel Level Lamp** – When this lamp is ON, it is time to stop the engine and add fuel. Remember to let the engine cool before adding fuel.



D. **Low Battery Fluid Lamp** – This lamp goes ON when the battery fluid is low. If this lamp goes ON during normal operation of the generator, stop the engine and fill the battery with distilled water to the specified level.

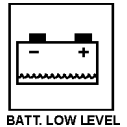

E. **Clogged Air Filter Lamp** – This lamp goes ON when the air filter is clogged. If this lamp goes ON during normal operation of the generator, stop the engine and replace the air filter.



7. **Pre-Heat Lamp** – Indicates that the glow plugs of the diesel engine are hot and the engine is ready to be started.



8. **Pre-Heat Button** – Press hold this button until the preheat lamp is lit (ON).



9. **Throttle Handle** - This handle controls the speed of the engine (low or high).

DCA-125SSK — OUTPUT TERMINAL PANEL OVERVIEW

DCA-125SSK FAMILIARIZATION

The "Output Terminal Panel" is provided with the following:

- Three 120/240V output receptacles, 50 amp
- Two 120V input receptacles, 20 amp
- 3 Load Circuit Breakers 250V @50 amps
- 2 Load GFCI Circuit Breakers 120V @ 20amps

Control Box

The "Control Box" is provided with the following:

- Main Circuit Breaker 300 amps
- Over-Current Relay

Output Terminal Panel

The Output Control Panel (See Figure 9) is located on the right hand side (left from control panel) of the generator. The UVW lugs are protected by a face plate cover that can be secured in the close position by a pad lock. (See Figure 6).

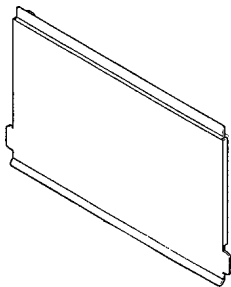

FIGURE 6. Output Terminal Cover

120 Volt Receptacle

Two GFCI Duplex Nema 5-20R (120V, 20 Amp) receptacle is provided on the output terminal. This receptacle can be used anytime the generator is in operation. The receptacle is controlled by the circuit breaker located on the control panel.

Pressing the reset button resets the receptacle after being tripped. Pressing the "Test Button" (See Figure 7) in the center of this receptacle will check the GFCI function. The receptacle should be tested at least once a month.

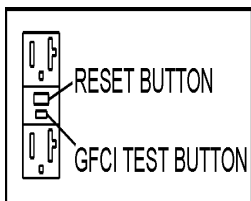

FIGURE 7. GFCI Test Button

Connecting Load

Loads can be connected to the generator by the UVW Lugs or the convenience receptacles. (See figure 8). Make sure to read the operation manual before attempting to connect a load to the generator.

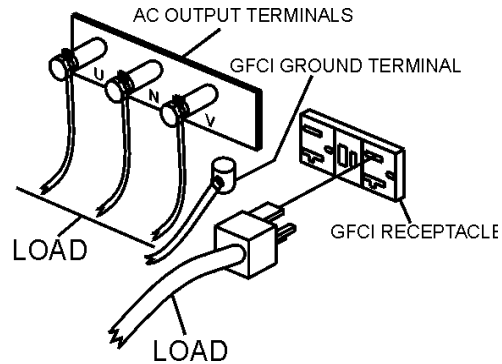

FIGURE 8. Connecting Load

Circuit Breakers

To protect the generator from an overload, a 3-pole, 300 amp, **main** circuit breaker is provided to protect the UVW output terminals from overload. In addition two single-pole, 20 amp **GFCI** circuit breakers are provided to protect the GFCI receptacles from overload. Three 50 amp **load** circuit breakers have also been provided to protect the load side of the generator from overload. Make sure to switch **ALL** circuit breakers to the "OFF" position prior to starting the engine.

Maximum Output

The entire load connected to the UVW Lugs, all four slots in the duplex receptacles, and the must not exceed 110 kW in standby or 100 kW in prime output.

Twist Lock Dual Voltage Receptacles - To use these receptacles, place the voltage selector switch in the single phase 240/120 voltage position and adjust the output voltage to 240 volts with the voltage regulator on the Control Panel (see figure). Place the voltmeter change-over switch to the U-W position and the ammeter change-over switch to the U or W to read the output.

DCA-125SSK — OUTPUT TERMINAL PANEL OVERVIEW

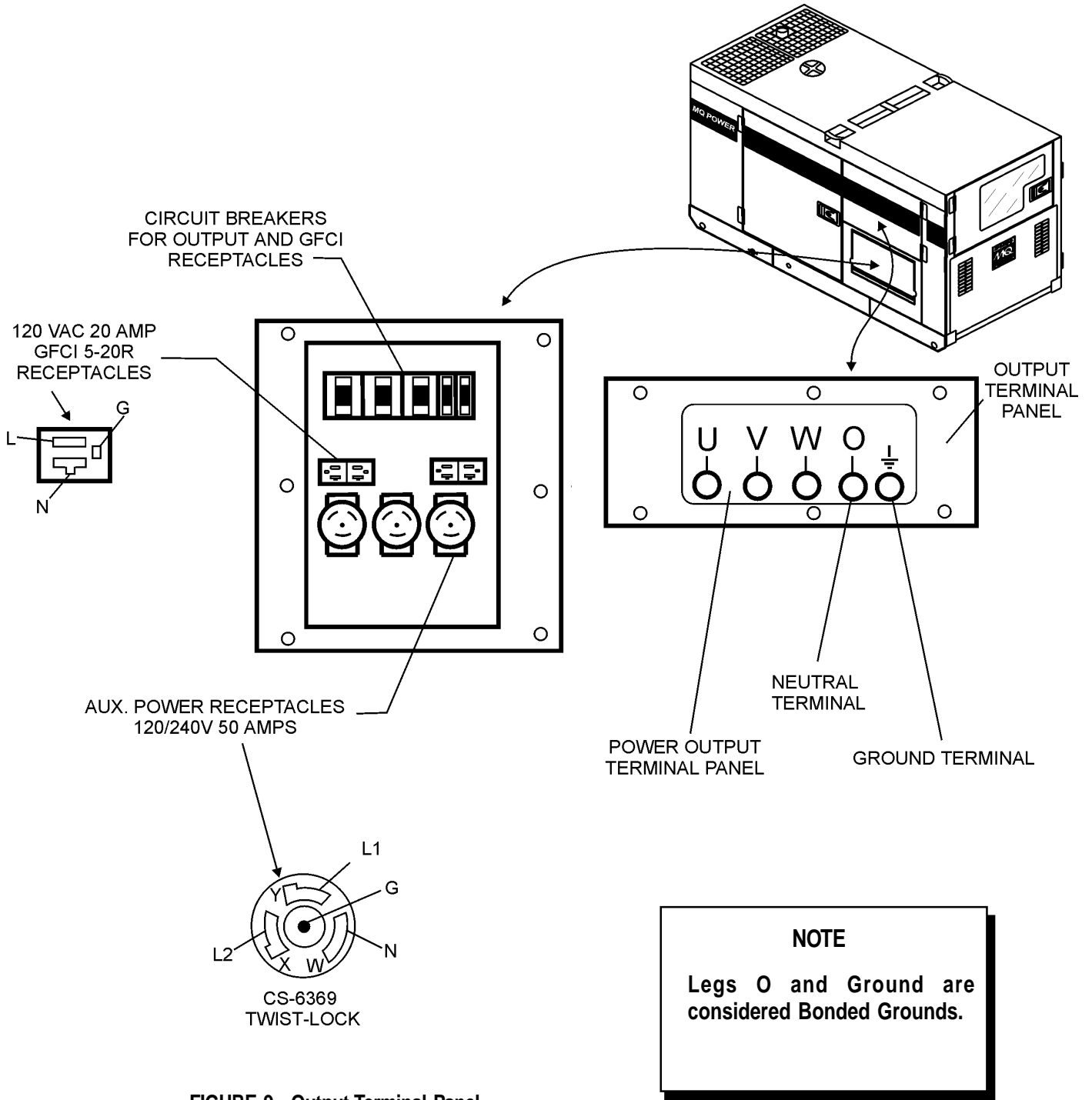

FIGURE 9. Output Terminal Panel

DCA-125SSK — OUTPUT TERMINAL PANEL OVERVIEW

Output Terminal Panel Available Voltages

A wide range of voltages are available to supply load to many different applications. Voltages may be selected by using the voltage selector switch and how you hookup your hard wire connection to the generator. To obtain some of the voltages listed, fine adjustment with the Voltage Regulator on the control panel is necessary. See the table below (Table 2) for a list of available voltages the generator is able to supply.

TABLE 2. VOLTAGES AVAILABLE						
MODEL	DCA125SSK					
3 PHASE VOLTAGE (SWITCHABLE)	208 VOLT	220 VOLT	240 VOLT	416 VOLT	440 VOLT	480 VOLT
SINGLE PHASE (SWITCHABLE)	120 VOLT	127 VOLT	139 VOLT	240 VOLT	254 VOLT	277 VOLT

Voltage Selector Switch

The voltage selector switch is located above the UVWO Hard Wire Hook-up Panel. It has been provided for ease of voltage selection.

CAUTION :



NEVER switch Voltage Selector Switch position while the engine is engaged.

Voltage Selector Switch Locking Button

The voltage selector switch has a locking button to protect the generator and generator load from being switched while the engine is running. To lock the Voltage Selector Switch, press in the red button located on the Voltage Selector Switch, and use a pad lock to hold it into this position.

Over Current Relay

An over current relay is connected to the circuit breaker. In an over current situation, both the circuit breaker and the over current relay may trip. If the circuit breaker can not be reset, the reset button on the over current relay must be pressed. The over current relay is located in the control box.

Maximum Amps

The following table show the maximum amps the entire generator can provide. Do not exceed the maximum amps listed. (See Table 3)

Table 3. Maximum Amps	
Model:	DCA125SSK
Rated Voltage	Maximum Amps
Single Phase 120 Volt	277.8 amps (4 wire)
Single Phase 240 Volt	138.9 amps (4 wire)
Three Phase 240 Volt	301 amps
Three Phase 480 Volt	150 amps

Receptacle Use

When the UVWO terminals are providing power, the receptacle power available decrease. Do not exceed receptacle power available listed on Table 4.

Table 4. Receptacle Use		
Power in Use		Receptacle Power Available
240/480V 3-Phase	240/120V Single Phase or Twist Lock CS6369	Duplex NEMA 5-20R 120V
KVA	KW	KW
125	72	0
121	70.8	1.2
117	69.6	2.4
113	68.4	3.6
108	67.2	4.8

DCA-125SSK — OUTPUT TERMINAL PANEL OVERVIEW

How to read the output terminal gauges.

The gauges and knobs on the control panel **DO NOT** effect the generator output in any fashion. They are there to simply help the operator observe how much power is being supplied produced at the UVWO legs.

When the Voltage selector switch is in the 240/120V position (see figure 10), place the AC Voltmeter Change-over switch to the W-U position and the AC ammeter Change-over Switch to the U or W position to read the output on the selected leg.

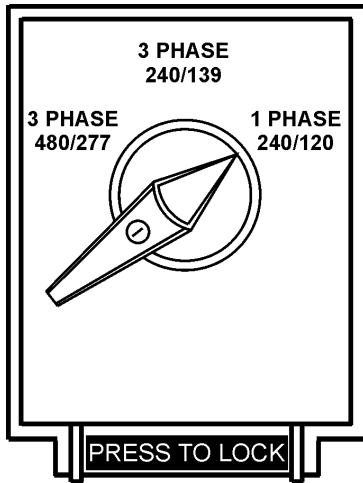

FIGURE 10. Voltage Selector Switch 240/120V Single Phase Position

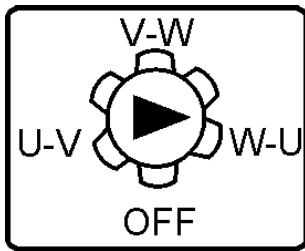

FIGURE 11. AC Voltmeter Change-over switch (Reading the W-U leg on the output terminal panel)

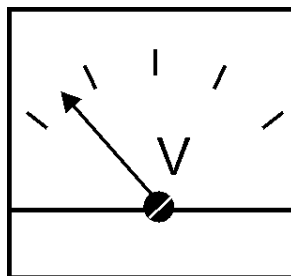

FIGURE 12. AC Voltmeter Gauge (Volt reading on W-U Lug)

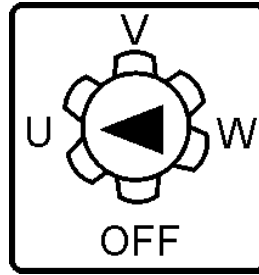

FIGURE 13. AC Ammeter Change-over Switch (Reading the U leg on the output terminal panel)

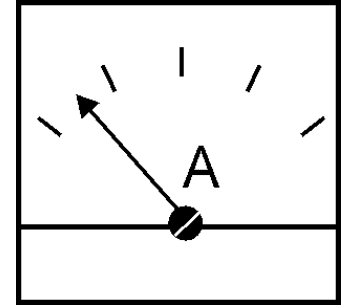

FIGURE 14. AC Ammeter (Amp reading on U lug)

NOTE

When using plural single phase voltages, make sure to balance the load on each of the single phase legs.

DCA-125SSK — OUTPUT TERMINAL PANEL OVERVIEW

240/120V Hard Wire Hookup

The output terminal panel, when supplying single phase 120 volts, will provide three legs available with 277.8 amps each on three different circuits. (See Figure 16 below.) The voltage selector switch must be set at the single phase 240/120V position. (See figure 15 below.)

The output terminal panel, when supplying single phase 240 volts, will provide one leg only with 138.9 amps available. (See Figure 16 below.) The voltage selector switch must be set at the single phase 240/120V position. (See figure 15 below.)

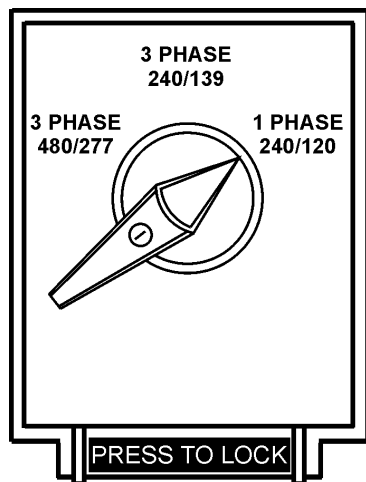

FIGURE 15. Voltage Selector Switch 240/120V Single Phase Position

480/240V Hard Wire Hookup

The output terminal panel, when supplying three phase 240 volts, will provide one circuit available at 301 amps with any two wires plus the ground. (See Figure 18 below.) The voltage selector switch must be set at the three phase 480/277V position. (See figure 17 below.)

The output terminal panel, when supplying 3 phase 480 volts, will provide one circuit available at 150 amps available with all three wires plus ground. (See Figure 18 below.) The voltage selector switch must be set at the three phase 480/277V position. (See figure 17 below.)

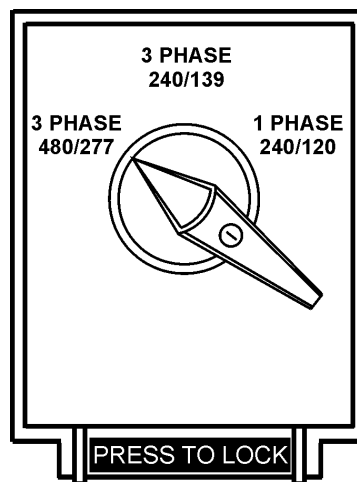

FIGURE 17. Voltage Selector Switch 480/277V Three Phase Position

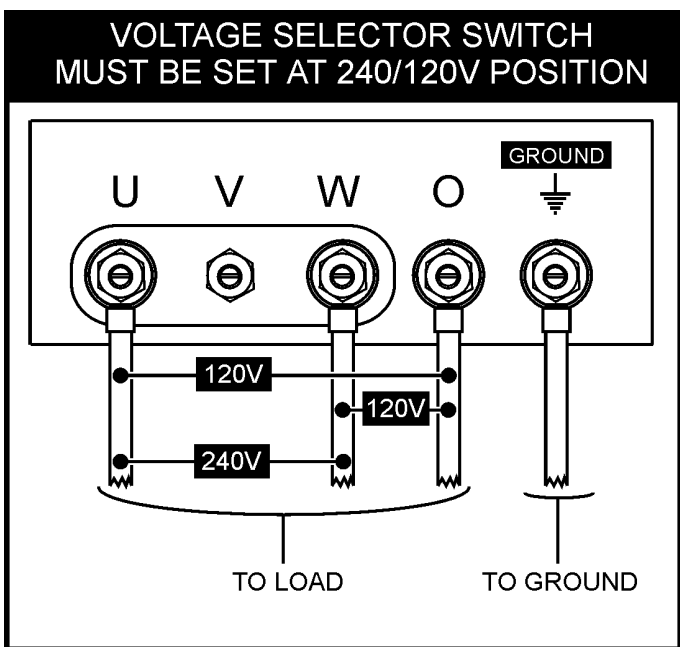

FIGURE 16. Hard Wire Hookup at 240/120V Position

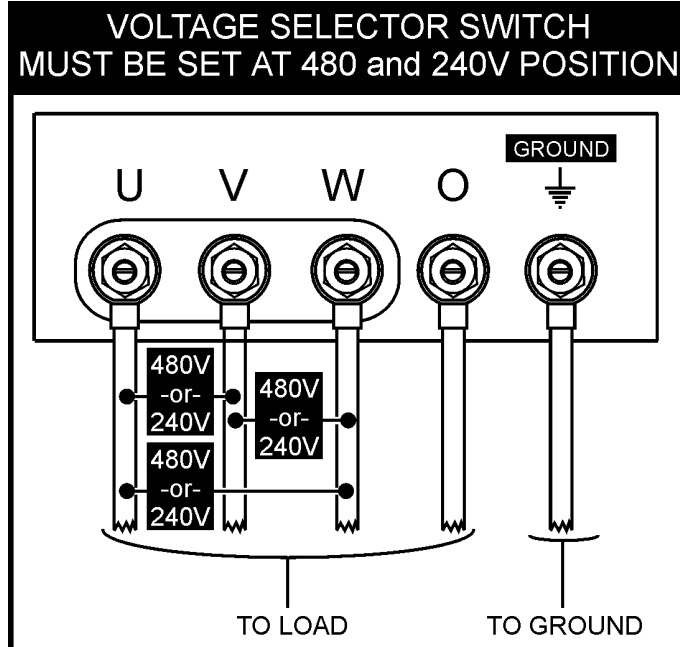

FIGURE 18. Hard Wire Hookup at 480/240V Position

DCA-125SSK — OUTPUT TERMINAL PANEL OVERVIEW

Voltage Selector Switch- 3 Phase 480/277V Position

The following are additional voltages available when the voltage selector switch is in the 3 phase 480/277V position. (See figure 19 below.)

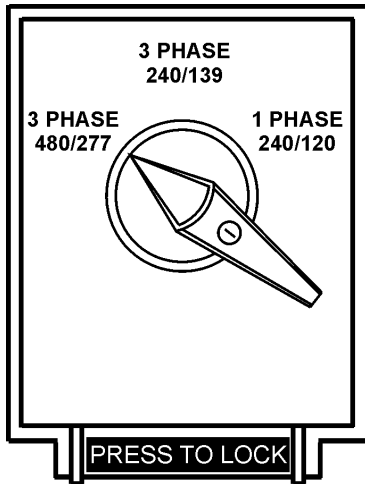

FIGURE 19. Voltage Selector Switch 480/277V Single Phase Position

3 Phase, 480V, 440V, or 416 Volt

The following connection, with the voltage selector switch locked into the 3 phase 480/277V position (See Figure 19), can offer **THREE PHASE** power at 480V, 440V, or 416V. After hooking up the hard wires to the lugs as shown in figure 21 below, 480V will be the voltage with the Voltage Regulator Knob turned toward maximum. 440 volt will be reached when the Voltage Regulator Knob is turned down, and 416 volt when the Voltage Regulator Knob is toward the lowest setting (See Figure 20).

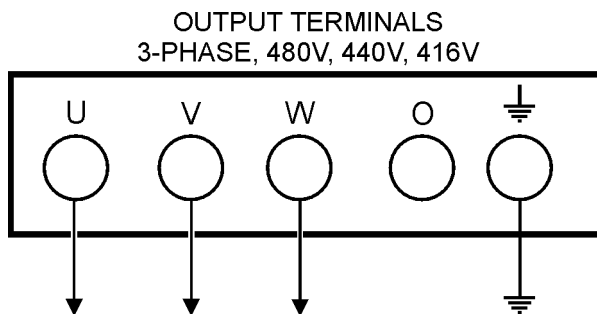

FIGURE 21. Hard Wire Hookup for Three Phase 480V, 440V, or 416V

Single Phase: 480V, 440V, or 416 Volt

The following connection, with the voltage selector switch locked into the 3 phase 480/277V position (See Figure 19), can offer **SINGLE PHASE** power at 480V, 440V, or 416V. After hooking up the hard wires to the lugs as shown in figure 22 below, 480V will be the voltage with the Voltage Regulator Knob turned toward maximum. 440 volt will be reached when the Voltage Regulator Knob is turned down, and 416 volt when the Voltage Regulator Knob is toward the lowest setting (See Figure 20).

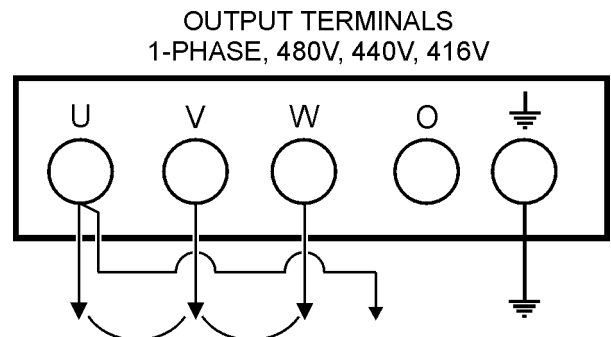

FIGURE 22. Hard Wire Hookup for Single Phase 480V, 440V, or 416V

Single Phase: 277V, 254V, or 240V

The following connection, with the voltage selector switch locked into the 3 phase 480/277V position (See Figure 19), can offer **SINGLE PHASE** power at 277V, 254V, or 240V. After hooking up the hard wires to the lugs as shown in figure 23 below, 277V will be the voltage with the Voltage Regulator Knob turned toward maximum. 254 volt will be reached when the Voltage Regulator Knob is turned down, and 240 volt when the Voltage Regulator Knob is toward the lowest setting (See Figure 20).

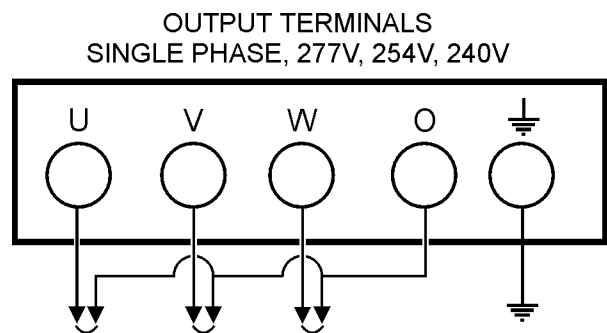

FIGURE 23. Hard Wire Hookup for Single Phase 277V, 254V, or 240V

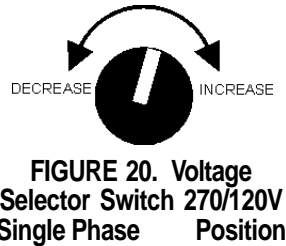

FIGURE 20. Voltage Selector Switch 270/120V Single Phase Position

DCA-125SSK — OUTPUT TERMINAL PANEL OVERVIEW

Voltage Selector Switch- 3 Phase 240/139V Position

The following are additional voltages available when the voltage selector switch is in the 3 phase 240/139V position. (See Figure 24 below.)

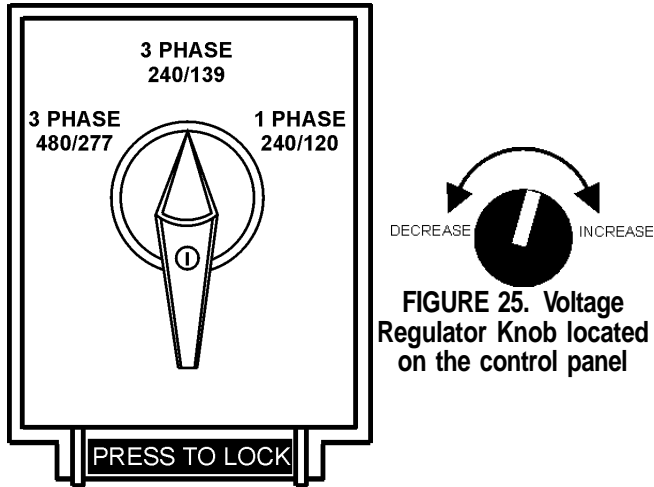

FIGURE 25. Voltage Regulator Knob located on the control panel

FIGURE 24. Voltage Selector Switch 240/139V Three Phase Position

3 Phase, 240V, 220V, or 208 Volt

The following connection, with the voltage selector switch locked into the 3 phase 270/139V position (See Figure 24), can offer **THREE PHASE** power at 270V, 220V, or 208V. After hooking up the hard wires to the lugs as shown in figure 26 below, 240V will be the voltage with the Voltage Regulator Knob turned toward maximum. 220 volt will be reached when the Voltage Regulator Knob is turned down, and 208 volt when the Voltage Regulator Knob is toward the lowest setting (See Figure 25).

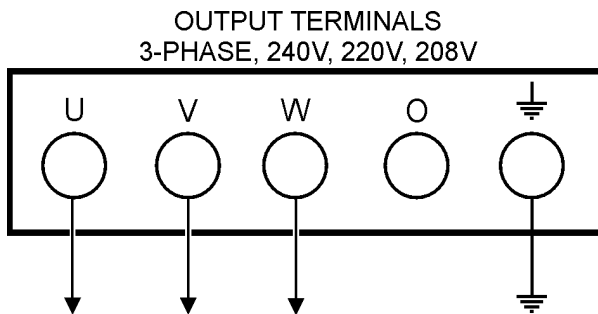

FIGURE 26. Hard Wire Hookup for Three Phase 240V, 220V, or 208V

Single Phase: 240V, 220V, or 208 Volt

The following connection, with the voltage selector switch locked into the 3 phase 240/139V position (See Figure 24), can offer **SINGLE PHASE** power at 240V, 220V, or 208V. After hooking up the hard wires to the lugs as shown in figure 27 below, 240V will be the voltage with the Voltage Regulator Knob turned toward maximum. 220 volt will be reached when the Voltage Regulator Knob is turned down, and 208 volt when the Voltage Regulator Knob is toward the lowest setting (See Figure 25).

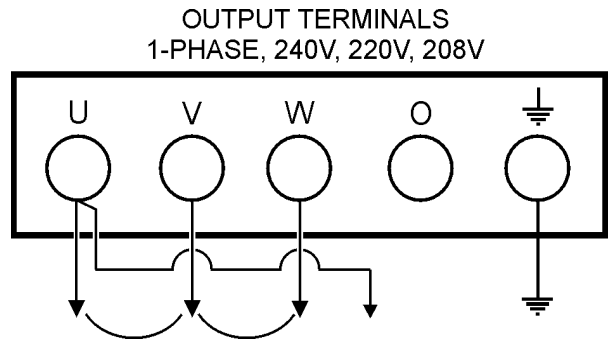

FIGURE 27. Hard Wire Hookup for Single Phase 240V, 220V, or 208V

Single Phase: 139V, 127V, or 120V

The following connection, with the voltage selector switch locked into the 3 phase 240/139V position (See Figure 24), can offer **SINGLE PHASE** power at 139V, 127V, or 120V. After hooking up the hard wires to the lugs as shown in figure 28 below, 139V will be the voltage with the Voltage Regulator Knob turned toward maximum. 127 volt will be reached when the Voltage Regulator Knob is turned down, and 120 volt when the Voltage Regulator Knob is toward the lowest setting (See Figure 25).

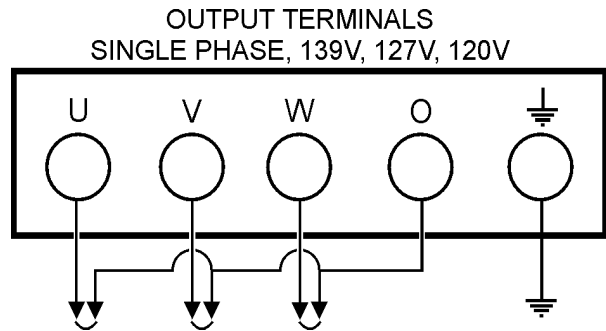

FIGURE 28. Hard Wire Hookup for Single Phase 139V, 127V, or 120V

DCA-125SSK — OUTPUT TERMINAL PANEL OVERVIEW

Voltage Selector Switch- Single Phase 240/120V Position

The following are additional voltages available when the voltage selector switch is in the single phase 240/120V position. (See Figure 29 below.)

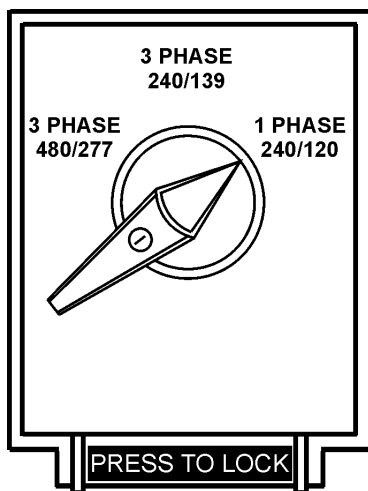

FIGURE 29. Voltage Selector Switch 240/120V Single Phase Position



FIGURE 30. Voltage Regulator Knob located on the control panel

Single Phase: 120 Volt

The following connection, with the voltage selector switch locked into the single phase 240/120V position (See Figure 29), will offer **SINGLE PHASE** power at 120V. After hooking up the hard wires to the lugs as shown in figure 32 below, use the Voltage Regulator Knob to fine tune to 120V. (See Figure 30).

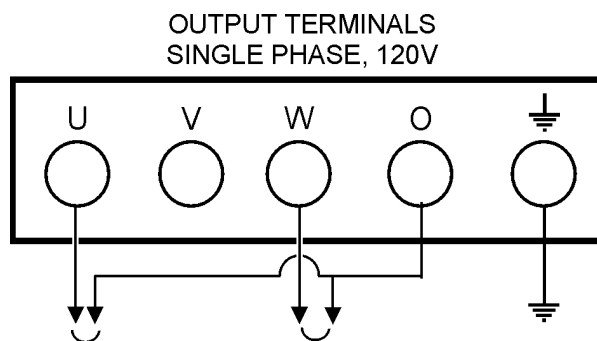

FIGURE 32. Hard Wire Hookup for Single Phase, 120 volt

Single Phase, 240 Volt

The following connection, with the voltage selector switch locked into the single phase 240/120V position (See Figure 29), will offer **SINGLE PHASE** power at 240V. After hooking up the hard wires to the lugs as shown in figure 31 below, use the Voltage Regulator Knob to fine tune to 240V. (See Figure 30).

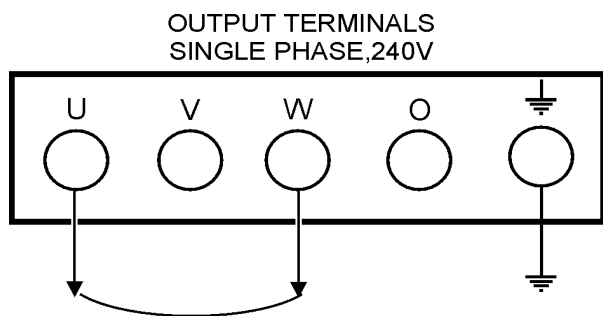

FIGURE 31. Hard Wire Hookup for Single Phase 240 volt

Outdoor Installation

Install the generator in a location where it will not be exposed to rain or sunshine. Make sure that the generator is on secure level ground so it cannot slide or shift around. Also install the generator so the exhaust will not be discharged in the direction of nearby homes.

The installation site must be relatively free from moisture and dust. All electrical equipment should be protected from excessive moisture. Failure to do will result in deterioration of the insulation and will result in short circuits and grounding.

Foreign materials such as dust, sand, lint and abrasive materials have a tendency to cause excessive wear, not only to the engine parts, but also to the alternator parts.

CAUTION :



Pay close attention to ventilation when operating the generator inside tunnels and caves. The engine exhaust contains noxious elements. Engine exhaust must be routed to a ventilated area.

Indoor Installation

Exhaust gases from diesel engines are extremely poisonous. Whenever an engine is installed indoors the exhaust fumes must be vented to the outside. The engine should be installed at least two feet from any outside wall. Using an exhaust pipe which is too long or too small can cause excessive back pressure which will cause the engine to heat excessively and possibly burn the valves.

DO NOT cover ventilation areas on the enclosure, covering the ventilation grids will cause the engine to over heat.

CAUTION :



An electric shock is apt to happen when vibrators are used. Pay close attention to handling when operating vibrators and always use rubber boots and gloves to insulate the body from electrical shock.

Generator Grounding

To guard against electrical shock and possible damage to the equipment, it is important to provide a good **EARTH** ground.

Article 250 (Grounding) of the National Electrical Code (NEC) provides guide lines for proper grounding and specifies that the cable ground shall be connected to the grounding system of the building as close to the point of cable entry as practical.

NEC articles 250-64(b) and 250-66 set the following grounding requirements:

1. Use one of the following wire types to connect the generator to earth ground.
 - a. Copper - 10 AWG (5.3 mm²) or larger.
 - b. Aluminum - 8 AWG (8.4 mm²) or larger.
2. When grounding the generator (Figure 9) connect the ground cable between the lock washer and the nut on the generator and tighten the nut fully. Connect the other end of the ground cable to earth ground.
3. NEC article 250-52(c) specifies that the earth ground rod should be buried a minimum of 8 ft. into the ground.

NOTE

When connecting the generator to any buildings electrical system **ALWAYS** consult with a licensed electrician.

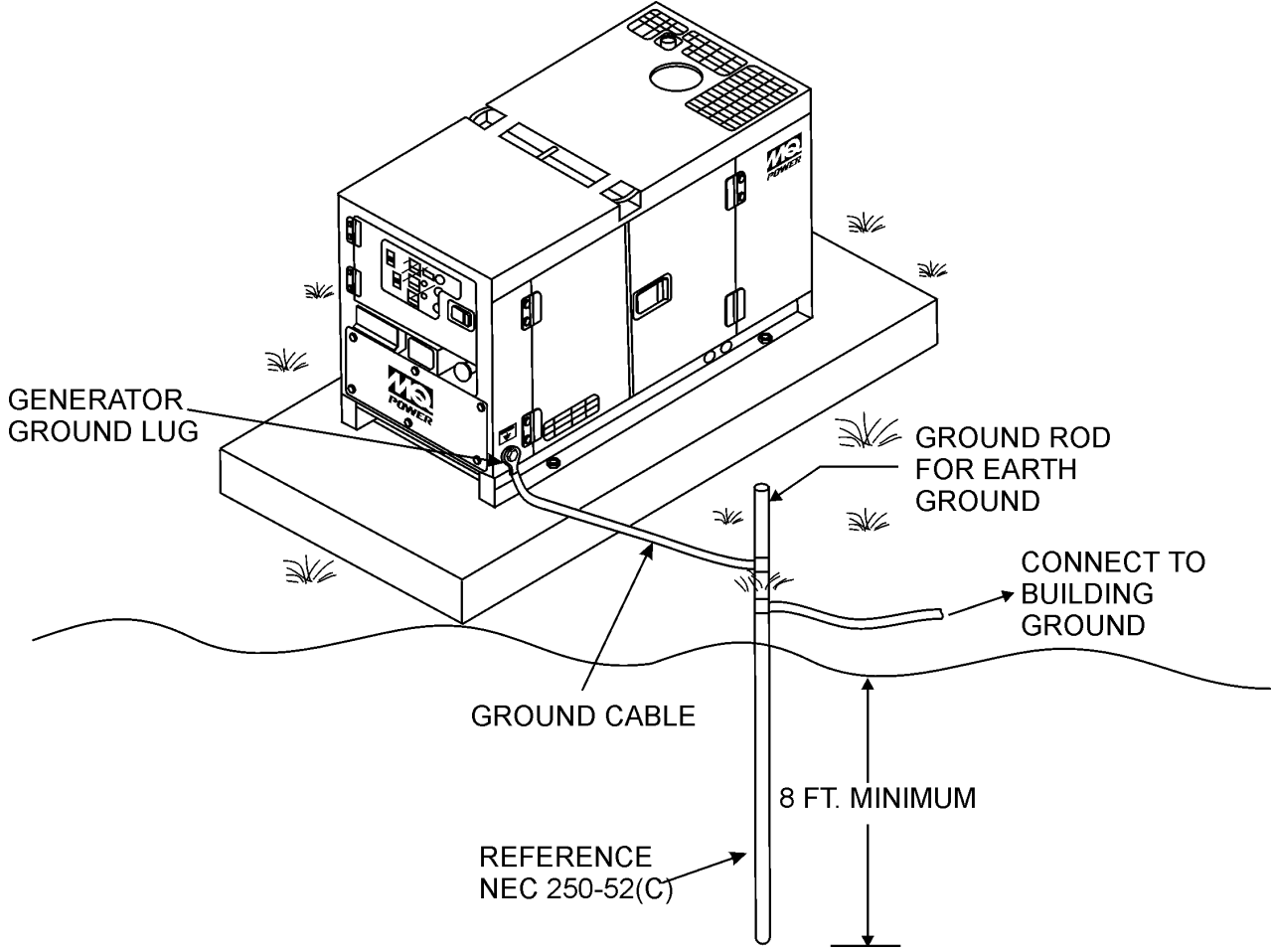

Figure 33. Typical Generator Grounding Application

General Inspection Prior to Operation

The DCA-125SSK generator has been thoroughly inspected and accepted prior to shipment from the factory. However, be sure to check for damaged parts or components, or loose nuts and bolts, which could have occurred in transit.

Extension Cable

When electric power is to be provided to various tools or loads at some distance from the generator, extension cords are normally used. Cables should be sized to allow for distance in length and amperage so that the voltage drop between the generator and point of use (load) is held to a minimum. Use Table 5 (cable selection guide) as a guide for selecting proper cable size.

Circuit Breakers

To protect the generator from an overload, a 3-pole, 400 amp, **main** circuit breaker is provided to protect the UVW output terminals from overload. In addition two single-pole, 20 amp **GFCI** circuit breakers are provided to protect the GFCI receptacles from overload. Three 50 amp **load** circuit breakers have also been provided to protect the load side of the generator from overload. Make sure to switch **ALL** circuit breakers to the "OFF" position prior to starting the engine.

NOTE

ALWAYS consult with a licensed electrician for correct extension cord wire size.

Table 5. Cable Selection (60 Hz, Single Phase Operation)

Current in Amperes	Load In Watts		Maximum Allowable Cable Length			
	At 120 Volts	At 240 Volts	#10 Wire	#12 Wire	#14 Wire	#16 Wire
2.5	300	600	1000 ft.	600 ft.	375 ft.	250 ft.
5	600	1200	500 ft.	300 ft.	200 ft.	125 ft.
7.5	900	1800	350 ft.	200 ft.	125 ft.	100 ft.
10	1200	2400	250 ft.	150 ft.	100 ft.	
15	1800	3600	150 ft.	100 ft.	65 ft.	
20	2400	4800	125 ft.	75 ft.	50 ft.	

CAUTION: Equipment damage can result from low voltage.

Lubrication Oil

Fill the engine crankcase with lubricating oil through the filler hole, but do not overfill. Make sure the generator is level. With the dipstick inserted all the way, but without being screw into the filler hole, verify that the oil level is maintained between the two notches (Figure 34) on the dipstick. See Table 6 for proper selection of engine oil.

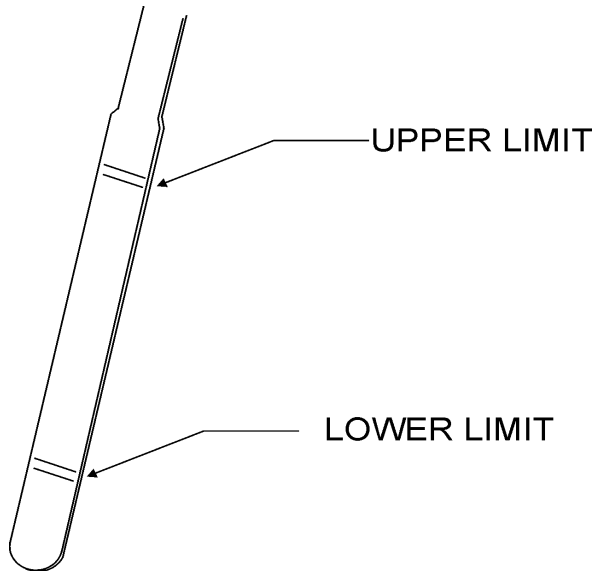

Figure 34. Engine Oil Dipstick

When checking the engine oil, be sure to check if the oil is clean and viscous. If the oil is not clean, drain the oil by removing the oil drain plug, and refill with the specified amount of oil as outlined in the **Komatsu Engine Owner's Manual**.

Fuel

Fill the fuel tank with clean and fresh **diesel fuel**. **DO NOT** fill the tank beyond capacity.

Pay attention to the fuel tank capacity when replenishing fuel. Refer to the fuel tank capacity listed on page 12, Specification Table 1.

The fuel tank cap must be closed tightly after filling. Handle fuel in a safety container. If the container does not have a spout, use a funnel. Wipe up any spilled fuel immediately.

CAUTION:



Never fill the fuel tank while the engine is running or in the dark. Diesel spillage on a hot engine can cause a fire or explosion. If diesel spillage occurs, wipe up the spilled diesel completely to prevent fire hazards.

Coolant

Use only drinkable tap water. If hard water or water with many impurities is used, the inside of the engine and radiator may become coated with deposits and cooling efficiency will be reduced.

An anticorrosion additive added to the water will help prevent deposits and corrosion in the cooling system. See the engine manual for further details.

Table 6. Recommended Motor Oil

Temperature Range	Type Oil
104° F ~ 23° F (40° C ~ -5°C)	SAE 30
23° F ~ 5° F (-5° C ~ -15°C)	SAE 20 or SAE 10W-30
Below 5° C (-15°)	SAE 10W or SAE 10W-30

CAUTION :



When adding coolant or antifreeze to the radiator, do not remove the radiator cap until the unit has completely cooled.

Day-to-day addition of coolant is done from the reserve tank. When adding coolant to the radiator, **DO NOT** remove the radiator cap until the unit has completely cooled. See Table 7. for engine, radiator, and reserve tank coolant capacities. Make sure that the coolant level in the reserve tank is always between the "H" and the "L" markings.

Table 7. Coolant Capacity

Engine and Radiator	7.4 Gal. (28 Liters)
Reserve Tank	2 Quarts (11.9 Liters)

Operation in Freezing Weather

When operating in freezing weather, be certain that the proper amount of antifreeze (Table 5) has been added.

Table 8. Anti-Freeze Operating Temperatures

Vol % Anti-Freeze	Freezing Point		Boiling Point	
	°C	°F	°C	°F
40	-24	-12	106	222
50	-37	-34	108	226

NOTE

When the antifreeze is mixed with water, the antifreeze mixing ratio must be less than 50%.

Cleaning the Radiator

The radiator may overheat if the fins become overloaded with dust or debris. Periodically clean the radiator fins with compressed air. Cleaning inside the machine is dangerous, so clean only with the engine turned off and the battery disconnected.

Air Cleaner

Periodic cleaning/replacement is necessary. Inspect it in accordance with the **Komatsu Engine Owner's Manual**.

Fan Belt Tension

A slack fan belt may contribute to overheating, or to insufficient charging of the battery. Inspect the fan belt for damage and wear and adjust it in accordance with the **Komatsu Engine Owner's Manual**.

The fan belt tension is proper if the fan belt bends 7 to 10 mm (Figure 35) when depressed with the thumb as shown below.

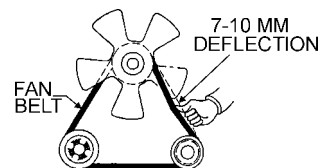

Figure 35. Fan Belt Tension

CAUTION :



Never place hands near the belts or fan while the generator set is running.

Battery

This unit is of negative ground. **DO NOT** connect in reverse. Always maintain battery fluid level between the specified marks. Battery life will be shortened, if the fluid level is not properly maintained. Add only distilled water when replenishment is necessary.

The battery is sufficiently charged if the specific gravity of the battery fluid is 1.28 (at 68° F). If the specific gravity should fall to 1.245 or lower, it indicates that the battery is dead and needs to be recharged or replaced.

Check to see whether the battery cables are loose. Poor contact may result in poor starting or malfunctions. Always keep the terminals firmly tightened. Coating the terminals with a thin film of grease will help to inhibit corrosion.

Battery Cable Installation

ALWAYS be sure the battery cables (Figure 36) are properly connected to the battery terminals as shown below. The **RED** cable is connected to the positive terminal of the battery, and the **BLACK** cable is connected to the negative terminal of the battery.

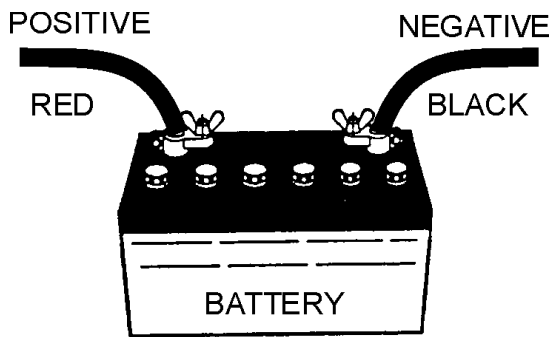

Figure 36. Battery Connections

CAUTION :



If the battery cable is connected incorrectly, electrical damage to the generator will occur. Pay close attention to the polarity of the battery when connecting the battery.

CAUTION :



Inadequate battery connections may cause poor starting of the generator, and create other malfunctions.

Wiring

Inspect the entire generator for bad or worn electrical wiring or connections. If any wiring or connections are exposed (insulation missing) replace wiring immediately.

Piping and Hose Connection

Inspect all piping, oil hose, and fuel hose connections for wear and tightness. Tighten all hose clamps and check hoses for leaks.

If any hose (fuel or oil) lines are defective replace them immediately.

When connecting battery do the following:

1. **ALWAYS** make sure that the Off/Manual/Auto switch is in the "OFF" position when connecting the battery. If the generator is equipped with an ignition switch, make sure the ignition switch is in the "OFF" position and the key is removed.
2. Place a small amount of grease around both battery terminals. This will ensure a good connection and will help prevent corrosion around the battery terminals.

Single Phase Load

Always be sure to check the nameplate on the generator and equipment to insure the wattage, amperage and frequency requirements are satisfactorily supplied by the generator for operating the equipment.

Generally, the wattage listed on the nameplate of the equipment is its rated output. Equipment may require 130—150% more wattage than the rating on the nameplate, as the wattage is influenced by the efficiency, power factor and starting system of the equipment.

NOTE

If wattage is not given on the equipment's name plate, approximate wattage may be determined by multiplying nameplate voltage by the nameplate amperage.

$$\text{WATTS} = \text{VOLTAGE} \times \text{AMPERAGE}$$

The power factor of this generator is 1.0. See Table 9. below when connecting loads.

Table 9. Power Factor By Load

Type Of Load	Power Factor
Single-phase induction motors	0.4 - 0.75
Electric heaters, incandescent lamps	1.0
Fluorescent lamps, mercury lamps	0.4 - 0.9
Electronic devices, communication equipment	1.0
Common power tools	0.8

Three Phase Load

When calculating the power requirements for 3-phase power use the following equation:

$$\text{KVA} = \frac{\text{VOLTAGE} \times \text{AMPERAGE} \times \sqrt{3}}{1000}$$

CAUTION:



Motors and motor-driven equipment draw much greater current for starting than during operation.

An inadequate size connecting cable which cannot carry the required load can cause a voltage drop which can burn out the appliance or tool and overheat the cable.

- When connecting a resistance load such as an incandescent lamp or electric heater, a capacity of up to the generating set's rated output (kW) can be used.
- When connecting a fluorescent or mercury lamp, a capacity of up to the generating set's rated output (kW) multiplied by 0.6 can be used.
- When connecting an electric drill or other power tools, pay close attention to the required starting current capacity.

When connecting ordinary power tools, a capacity of up to the generating set's rated output (kW) multiplied by 0.8 can be used.

CAUTION:



Before connecting this generator to any building's electrical system, a licensed electrician must install an isolation (transfer) switch. Serious injury or death may result without this transfer switch.

NOTE

If output (kVA) is not given on the equipment nameplate, approximate output may be determined by multiplying voltage by amperage by $\sqrt{3}$.

DCA-125SSK — GENERATOR START-UP PROCEDURE (MANUAL)

WARNING:



Before Starting Engine

The engine's exhaust contains harmful emissions. **ALWAYS** ventilate the exhaust when operating inside tunnels, excavations or buildings. Direct exhaust away from nearby

1. Check the lubricating oil level prior to starting the engine. Make sure the generator is level. The oil level must be maintained between two notches on the dipstick.
2. When there is not enough lubricating oil, fill the crankcase with high grade motor oil. Use a high quality detergent oil classified CC or higher (See Table 6 on page 31).
3. Check the coolant level in the radiator and subtank. Replenish with antifreeze as necessary. Always maintain the coolant level between the **FULL** and **LOW** markings on the coolant container. Be sure that the radiator cap is fastened securely.
4. Check the fuel level on the fuel gauge. If fuel is low, fill the fuel tank with clean fresh unleaded automotive diesel. If diesel spillage occurs, completely wipe up the spilled fuel immediately.

Before Starting Generator and Control Panel

CAUTION:



NEVER start the engine with the **main**, **GFCI** or **load** circuit breakers in the **ON** position.

1. Be sure to disconnect the electrical load and switch the **main**, **load** and **G.F.C.I.** circuit breakers (Figure 37) to the "OFF" position prior to starting the engine.

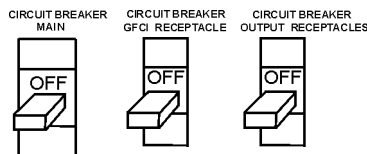

Figure 37. Main, GFCI and Load Circuit Breakers

2. Once it is determined if commercial power is required, connect the load to the UVW terminals as shown in Figure 38. These terminals can be found on the output terminal panel, see page 21, Figure 9. To gain access to the output terminals lift the UVW cover. Make sure to tighten terminal nuts securely to prevent load wires from slipping out.

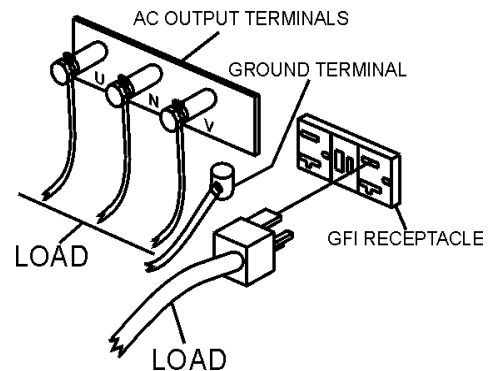

Figure 38. UVW Terminal Lugs (Load)

3. Connect the negative battery cable (BLACK) to the negative post on the battery (Figure 39).

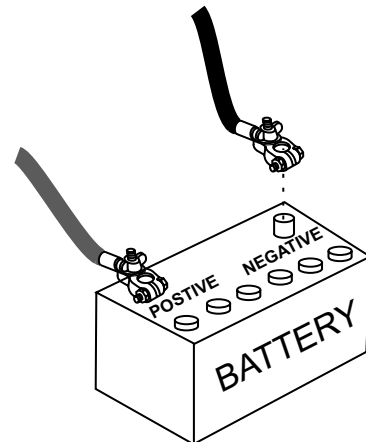
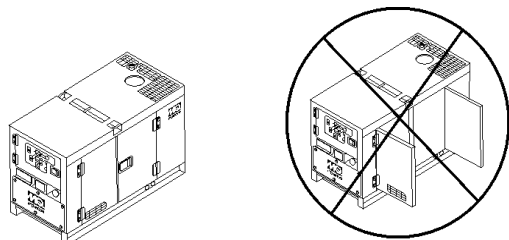

Figure 39. Battery Connections

DCA-125SSK — GENERATOR START-UP PROCEDURE (MANUAL)

4. Close all engine enclosure doors (Figure 40).



CORRECT **INCORRECT**
Figure 40. Engine Enclosure Doors

7. After engine starts, verify that the "Engine Running" status LED (Figure 44) on the Microprocessor Engine Control Module (MPEC) display is "ON" (lit).

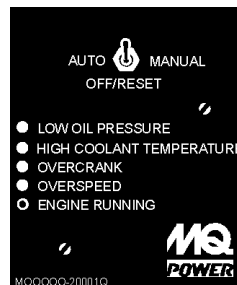

Figure 44. MPEC Engine Running Status LED

5. When starting the generator in **COLD** weather conditions, press and hold the engine preheat button (Figure 41) until the preheat lamp (Figure 42) is lit (ON).



**PRE-HEAT
 BUTTON**

Figure 41. Engine Pre-Heat Button



**PRE-HEAT
 LAMP**

Figure 42. Engine Pre-Heat Lamp

6. Place the Off/Manual/Auto switch (Figure 43) in the **MANUAL** position (down). Observe that the engine begins to crank.

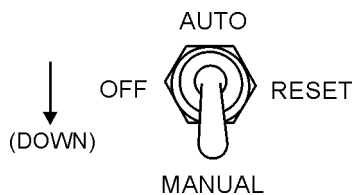

Figure 43. Off/Manual/Auto Switch (Manual)

8. If the unit has an ignition switch (Figure 45), turn the key to the right, until the engine starts. Then release the key to 'Run'.

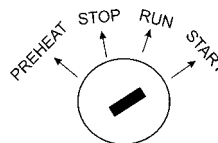

Figure 45. Ignition Switch (Run)

9. Pull and turn the engine throttle lever (Figure 46) to increase the engine speed to high.

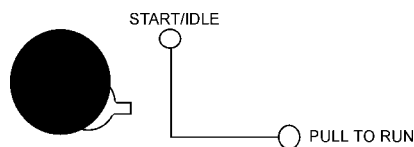

Figure 46. Engine Throttle Lever (High)

10. If the generator is equipped without the engine throttle lever, set the idle control switch to the "ON" position. (See Figure 47.)



Figure 47. Idle Control (ON)

DCA-125SSK — GENERATOR START-UP PROCEDURE (MANUAL)

11. The generator's frequency meter (Figure 48) displays the 60 cycle output frequency in **HERTZ**.

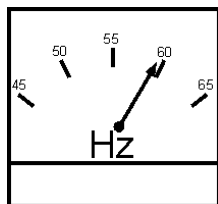

Figure 48. Frequency Meter (Hz)

12. The generator's voltage meter (Figure 49) displays the 120 VAC in **VOLTS**. If the voltage is not within the specified frequency tolerance, use the voltage adjustment control knob (Figure 50) to increase or decrease the desired voltage.

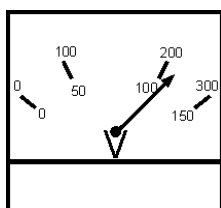

Figure 49. Voltage Meter (Volts)

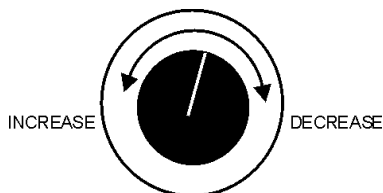

Figure 50. Voltage Adjust Control Knob

13. The ammeter (Figure 51) will indicate zero amps with no load applied. When a load is applied, this meter will indicate the amount of current that the load is drawing from the generator's alternator.

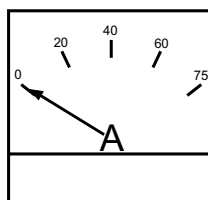

Figure 51. Ammeter (No Load)

14. The engine oil pressure gauge (Figure 52) will indicate the oil pressure (kg/cm²) of the engine. Under normal operating conditions the oil pressure should be approximately 25 psi.

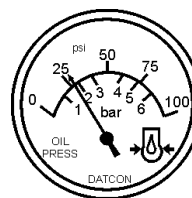

Figure 52. Oil Pressure Gauge

15. The coolant temperature gauge (Figure 53) will indicate the coolant temperature. Under normal operating conditions the coolant temperature should be between 105 and 215 degrees Fahrenheit (Green Zone).

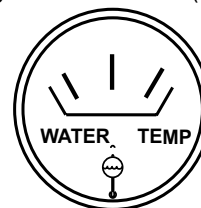

Figure 53. Coolant Temperature Gauge

16. The tachometer (Figure 54) will indicate the speed of the engine when the generator is operating. Under normal operating conditions this speed should be approximately 1800 RPM's.

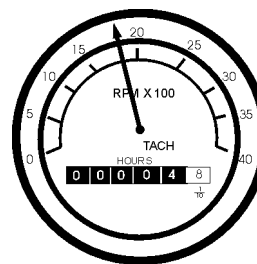

Figure 54. Engine Tachometer

DCA-125SSK — GENERATOR START-UP PROCEDURE (AUTO)

17. After the engine has been running for a few minutes, look at the status LED'S on the "MPEC" display (See Figure 44 on page 36) and check it for any abnormal conditions. If any abnormal conditions exist, shut down the engine and take corrective action to solve the problem.
18. If there are no abnormal problems shown on the "MPEC" LED display, turn the MAIN, GFCI and LOAD circuit breakers to their ON position (Figure 55).

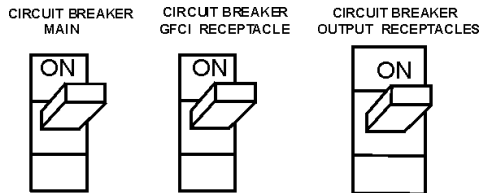

Figure 55. Main and GFCI Circuit Breakers

19. Look at the generator's ammeter (Figure 56) and verify that it reads the anticipated amount of current with respect to the load. Remember the ammeter will only display a current reading if the load is in use.

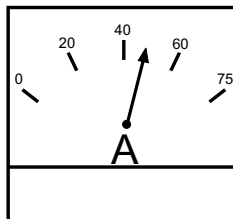
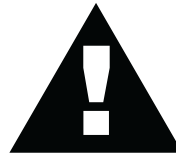

Figure 56. Ammeter (Load)

20. The generator will run until manually stopped or an abnormal condition occurs.

CAUTION:



Before connecting this generator to any building's electrical system, a **licensed electrician** must install an isolation (transfer) switch. Serious ***injury*** or ***death*** may result without this transfer switch.

Starting the generator in the "AUTO" mode is similar to starting the generator in the "MANUAL" mode, with a few exceptions.

CAUTION:



When running the generator in the **AUTO** mode, remember the generator can start up at any time without warning. **NEVER** attempt to perform any maintenance when the generator is in the auto mode.

If the generator is equipped with an MPEC, when starting generator in Auto mode use the "Manual Start-up" procedure except where noted (see below).

1. Perform steps 1 through 6 (Before Starting, page 35) as outlined in the manual starting procedure.
2. Place the Off/Manual/Auto switch (Figure 57) in the **AUTO** position (up). Observe that the engine begins to crank.

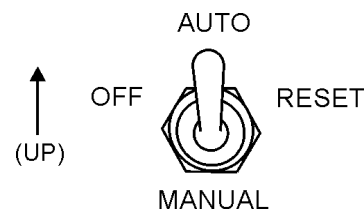

Figure 57. Off/Manual/Auto Switch (Manual)

3. Continue to follow the steps outline in the manual start-up procedure (start at step 9, page 36).

DCA-125SSK — GENERATOR SHUTDOWN PROCEDURE

Engine Shutdown

To shutdown the generator use the following procedure:

1. Place both the **MAIN**, **GFCI** and **LOAD** circuit breakers to the "OFF position"
2. Turn the Engine Throttle Handle (Figure 58) to the left and push in to set the speed to 'low'.

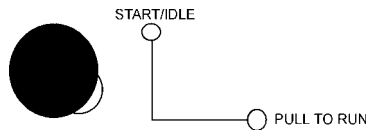

Figure 58. Engine Throttle Lever (low)

3. If the generator is equipped with an idle control switch, set the switch to "OFF" position. (See Figure 59 below.)



Figure 59. Idle Control Switch (OFF)

4. Let the engine cool by running it for 3-5 minutes with no load applied.
5. Place the Off/Manual/Auto Switch (Figure 60) in the "OFF/RESET" position.

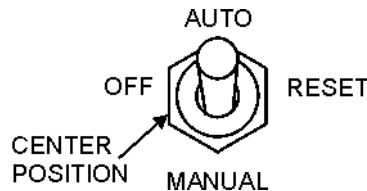

Figure 60. Off/Manual Auto Switch (OFF)

6. Verify that the "Engine Running" status LED (Figure 61) on the Microprocessor Engine Control Module (MPEC) display is "OFF" (not lit).



Figure 61. MPEC Engine Running Status LED (OFF)

7. If the generator is equipped with an ignition switch, (Figure 62) turn the key to the left to the "OFF" position turn off the engine.

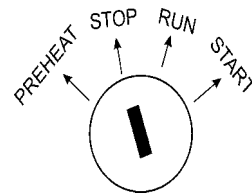

Figure 62. Off/Manual Auto Switch (OFF)

8. Remove the load from the UVW terminal strip. (See figure 9 on page 21.)

Towing Safety Precautions

CAUTION :



Check with your county or state safety towing regulations department before towing your generator.

To reduce the possibility of an accident while transporting the generator on public roads, always make sure that the trailer that supports the generator and the towing vehicle are in good operating condition and both units are mechanically sound.

The following list of suggestions should be used when towing your generator:

- Make sure the hitch and coupling of the towing vehicle are rated equal to, or greater than the trailer "gross vehicle weight rating" (GVWR).
- **ALWAYS** inspect the hitch and coupling for wear. **NEVER** tow a trailer with defective hitches, couplings, chains etc.
- Check the tire air pressure on both the towing vehicle and the trailer. Also check the tire tread wear on both vehicles.
- **ALWAYS** make sure the trailer is equipped with a "Safety Chain".

- **ALWAYS** attach trailer's safety chain to bumper of towing vehicle.
- **ALWAYS** make sure that the vehicle and trailer directional, backup, brake, and trailer lights are connected properly and are working properly.
- Remember the maximum speed unless otherwise posted for highway towing is **45 MPH**. Recommended off-road towing is not to exceed **10 MPH** or less depending on type of terrain.
- Place *chocked blocks* underneath wheel to prevent **rolling**, while parked.
- Place *support blocks* underneath the trailer's bumper to prevent **tipping**, while parked.
- Use the trailer's hand winch to adjust the height of the trailer, then insert locking pin to lock wheel stand in place, while parked.
- Avoid sudden stops and starts. This can cause skidding, or jackknifing. Smooth, gradual starts and stops will improve gas mileage.
- Avoid sharp turns to prevent rolling.
- Remove wheel stand when transporting.
- **DO NOT** transport generator with fuel in tank.

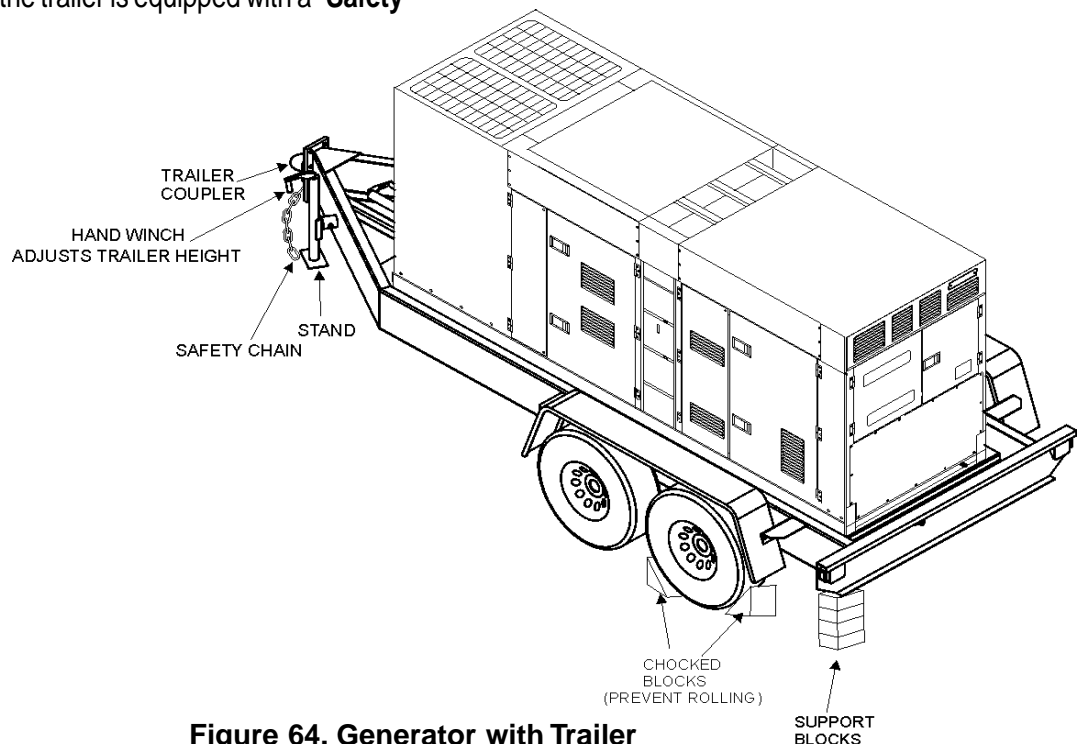

Figure 64. Generator with Trailer

CAUTION:



ALWAYS make sure the trailer is in good operating condition. Check the tires for proper inflation and wear. Also check the wheel lug nuts for proper tightness.

Explanation of Chart:

This section is intended to provide the user with trailer service and maintenance information. The service and maintenance guidelines referenced in this section apply a wide range of trailers. Remember periodic inspection of the trailer will ensure safe towing of the equipment and will prevent damage to the equipment and personal injury.

It is the purpose of this section to cover the major maintenance components of the trailer. The following trailer components will be discussed in this section:

- Brakes
- Tires
- Lug Nut Torquing
- Suspension
- Electrical
- Brake Troubleshooting Tables

Use the following definitions while reading Table 1.

1. **Fuel Cell** - Provides an adequate amount of fuel for the equipment in use. Fuel cells must be empty when transporting equipment.
2. **Braking System** - System employed in stopping the trailer. Typical braking systems are electric, surge, hydraulic, hydraulic-surge and air.
3. **GVWR**- Gross Vehicle Weight Rating (GVWR), is the maximum number of pounds the trailer can carry, including the fuel cell (empty).
4. **Frame Length** - This measurement is from the ball hitch to the rear bumper (reflector).
5. **Frame Width** - This measurement is from fender to fender.
6. **Jack Stand** - Trailer support device with maximum pound requirement from the tongue of the trailer.

7. **Coupler** - Type of hitch used on the trailer for towing.
8. **Tire Size** - Indicates the diameter of the tire in inches (10,12,14, etc.), and the width in millimeters (175,185,205, etc.). The tire diameter must match the diameter of the tire rim.
9. **Tire Ply** - The tire ply (layers) number is rated in letters; 2-ply,4-ply,6-ply, etc.
10. **Wheel Hub** - The wheel hub is connected to the trailer's axle.
11. **Tire Rim** - Tires are mounted on a tire rim. The tire rim must match the size of the tire.
12. **Lug Nuts** - Used to secure the wheel to the wheel hub. Always use a torque wrench to tighten down the lug nuts. See Table 4 and Figure 5 for lug nut tightening and sequence.
13. **Axle** - Indicates the maximum weight the axle can support in pounds, and the diameter of the axle expressed in inches (see Table 3 on page 17). Please note that some trailers have a double axle. This will be shown as 2-6000 lbs., meaning two axles with a total weight capacity of 6000 pounds.
14. **Suspension** - Protects the trailer chassis from shock transmitted through the wheels. Types of suspension used are leaf, Q-flex, and air ride.
15. **Electrical** - Electrical connectors (looms) are provided with the trailer so the brake lights and turn signals can be connected to the towing vehicle. See page 16 for proper wiring connections.
16. **Application** - Indicates which units can be employed on a particular trailer.

DCA-125SSK — TRAILER-SPECIFICATIONS

Table 10. Specifications

MODEL	APPLICATION	FUEL CELL	BRAKE SYSTEM	GVWR	FRAME LENGTH	FRAME WIDTH	JACK STAND
TRLR-10-15	TLG-12, DCA15, TLW-300	NO	NO	1900LBS	96"	50"	800LB. FULL TILT WHEEL
TRLR-10X	TLG-12, DCA15, TLW-300	NO	NO	1900LBS	96"	50"	800LB. FULL TILT WHEEL
TRLR-10XF	TLG-12, DCA15, TLW-300	51 GAL	NO	1900LBS	96"	50"	800LB. FULL TILT WHEEL
TRLR-225W	DCA-10	NO	NO	2200LBS	85"	42"	800LB. FULL TILT WHEEL
BLW-400	BLW-400	NO	ELECTRIC	2700LBS	W/MAST 154" W/O 124"	55" (78" TALL)	800LB. FULL TILT WHEEL
TRLR-15XF	DCA-15	41 GAL	NO	2700LBS	124"	55"	800LB. FULL TILT WHEEL
TRLR-50X	DCA-25	NO	NO	2700LBS	124"	55"	800LB. FULL TILT WHEEL
TRLR-50XF	DCA-25	41 GAL	NO	2700LBS	124"	55"	800LB. FULL TILT WHEEL
TRLR-25SBT	DCA-25	NO	NO	2990LBS	120"	66"	800LB. FULL TILT WHEEL
TRLR-70W	DCA-45, -60, 70	NO	SURGE	7000LBS	186"	77"	2000LB. FLAT PAD
TRLR-70X	DCA-45, -60, 70	OPT	SURGE	7000LBS	138"	66"	2000LB. FLAT PAD
TRLR-70XF	DCA-45, -60, 70	53 GAL	SURGE	7000LBS	138"	66"	2000LB. FLAT PAD
TRLR-100XF	DCA-100, 125	150 GAL	HYDRAULIC SURGE	7000LBS	190"	76"	2000LB. FLAT PAD
TRLR-85/125	DCA-85, 100, 125	145 GAL	HYDRAULIC	10000LBS	186"	77"	2000LB. FLAT PAD
TRLR-150XF	DCA-150, 180	200 GAL	HYDRAULIC SURGE	11160LBS	204"	84"	5000 LB. FLAT PAD
TRLR-220XF	DCA-220	250 GAL	HYDRAULIC SURGE	14000LBS	222"	83"	5000 LB. FLAT PAD
TRLR-300XF	DCA-300	250 GAL	HYDRAULIC SURGE	18000LBS	238"	83"	5000 LB. FLAT PAD
TRLR-400XF	DCA-400	350 GAL	ELECTRIC	18000LBS	238"	83"	5000 LB. FLAT PAD
TRLR-600XF	DCA-600, 800	550 GAL	AIR	30000LBS	384"	96"	5000 LB. FLAT PAD
TRLR-800SX	DCA-600, 800	550 GAL	AIR	30000LBS	384"	96"	5000 LB. FLAT PAD

DCA-125SSK — TRAILER-SPECIFICATIONS

Table 11. Specifications (Con't)

MODEL	COUPLER	TIRES	WHEELS	AXLE	HUBS	SUSPENSION	ELECTRICAL
TRLR-10-15W	2" BALL CLASS 2 ADJUSTABLE	175-13C	13"X4.50"	2200# 2X2	5 LUG	3 LEAF	4 WIRE LOOM W/ 4 POLE FLAT
TRLR-10X	2" BALL CLASS 2 ADJUSTABLE	175-13C	13"X4.5"	2200#2X2	5 LUG	3 LEAF	4 POLE FLAT
TRLR-10XF	2" BALL CLASS 2 ADJUSTABLE	175-13C	13"X4.5"	2200#2X2	5 LUG	3 LEAF	4 POLE FLAT
TRLR-225W	2" BALL CLASS 2 ADJUSTABLE	175-13B	13X4.5"	2200#2X2	5 LUG	Q FLEX	4 POLE FLAT
BLW 400	2" BALL CLASS 2 ADJUSTABLE	175-13C	13 X 4.5"	2200#2X2	5 LUG	3 LEAF	4 POLE FLAT
TRLR-15XF	2" BALL CLASS	B78-13LRC	13"X4.50"	3500# 2-1/2"	5 LUG	4 LEAF	4 POLE RUBBER FLAT
TRLR-50X	2" BALL CLASS	B78-13LRC	13"X4.50"	3500lbs. 2-3/8"	5 LUG	4 LEAF	4 POLE RUBBER FLAT
TRLR-50XF	2" BALL CLASS	B78-13LRC	13"X4.50"	3500lbs. 2-3/8"	5 LUG	4 LEAF	4 POLE RUBBER FLAT
TRLR-70W	2" BALL CLASS 3" ADJUSTABLE	205-14C BIAS (4)	14"X5"	3500lbs. 3"	5 LUG	5 LEAF	4 POLE RUBBER FLAT
TRLR-70X	2" BALL CLASS 3" ADJUSTABLE	205-14C BIAS (4)	14"X5"	3500lbs 3"	5 LUG	5 LEAF	4 POLE RUBBER FLAT
TRLR-70XF	2" BALL CLASS 3" ADJUSTABLE	205-14C BIAS (4)	14"X5"	3500lbs. 3"	5 LUG	5 LEAF	4 POLE RUBBER FLAT
TRLR-100XF	ADJUSTABLE 2-5/6 OPT 3" EYE	205-15C BIAS (4)	14"X5.5"	3500lbs 3"	5 LUG	5 LEAF	4 WIRE LOOM
TRLR-85/125	ADJUSTABLE 2-5/6 OPT 3" EYE	ST225/75R15D RADIAL (4)	14"x6"	(2)-6000lbs	6 LUG	7 LEAF	4 WIRE LOOM
TRLR-150XF	3" BALL EYE	750-16 E BIAS (4)	16"X7"	(2)-6000lbs	8 LUG	7 LEAF	4 WIRE LOOM
TRLR-220XF	3" EYE ADJUSTABLE	ST235/85R16E RADIAL(4)	16"X7"	(2)-7000lbs	8 LUG	Q FLEX	4 WIRE LOOM
TRLR-300XF	3" EYE ADJUSTABLE	ST235/85R16E RADIAL(6)	16"X7"	(2)-6000lbs	8 LUG	Q FLEX	4 WIRE LOOM
TRLR-400XF	3" EYE ADJUSTABLE	ST235/85R16E RADIAL(6)	16"X7"	(3)-7000lbs.	8 LUG	Q FLEX	4 WIRE LOOM
TRLR-600XF	5TH WHEEL	ST215/75R17.5H RADIAL (8)	16"X7"	(3)-10000lbs	8 LUG	7 LEAF	6 WIRE LOOM
TRLR-800AR	5TH WHEEL	ST215/75R17.5H RADIAL (8)	16"X7"	(3)-10000lbs	8 LUG	AIR-RIDE	6 WIRE LOOM

Brakes

If your trailer has a braking system, the brakes should be inspected the first 200 miles of operation. This will allow the brake shoes and drums to seat properly. After the first 200 mile interval, inspect the brakes every 3,000 miles. If driving over rough terrain, inspect the brakes more frequently.

Electric Brakes

Electrically actuated brakes (Figure 73) are similar to hydraulic brakes. The basic difference is that hydraulic brakes are actuated by an electromagnet.

Listed below are some of the advantages that electric brakes have over hydraulic brakes:

- An electric brake system can be manually adjusted to provide the corrected braking capability for varying road and load conditions.
- An electric brake system can be modulated to provide more or less braking force, thus easing the brake load on the towing vehicle.
- An electric brake system has very little lag time between the time the vehicle's brakes are actuated and the trailer's brakes are actuated.
- An electric brake system can provide an independent emergency brake system.

Road testing is necessary in order to properly synchronize the towing vehicle's braking to the trailer's braking. Brake lockup, grabbiness, or harshness is due to lack of

synchronization between the tow vehicle and the trailer being towed or under-adjusted brakes.

Before any brake synchronizations adjustments can be made, the trailer brakes should be burnished-in by applying the brakes 20-30 times with approximately a 20 m.p.h. decrease in speed, e.g. 40 m.p.h. to 20 m.p.h.. Allow ample time for brakes to cool between application. This allows the brake shoes to slightly be seated into the brake drum surface.

Figure 2 displays the major electric brake components that will require inspection and maintenance. Please inspect these components as required. Refer to Table 5 for electric brake troubleshooting guidelines.

Electric Brake Adjustment

1. Place the trailer on jack stands. Make sure the jack stands are placed on secure level ground.
2. Check the wheel and drum for free rotation.
3. Remove the adjusting hole cover from the adjusting slot at the bottom brake backing plate.
4. With a screwdriver or standard adjusting tool, rotate the star wheel of the adjuster assembly to expand the brake shoes.
5. Adjust the brake shoes outward until the pressure of the lining against the wheel drum makes the wheel difficult to turn.
6. Rotate the star wheel in the opposite direction until the wheel rotates freely with slight lining drag.
7. Replace the adjusting hole cover and lower the trailer to the ground.
8. Repeat steps 1 through 6 on the remaining brakes.

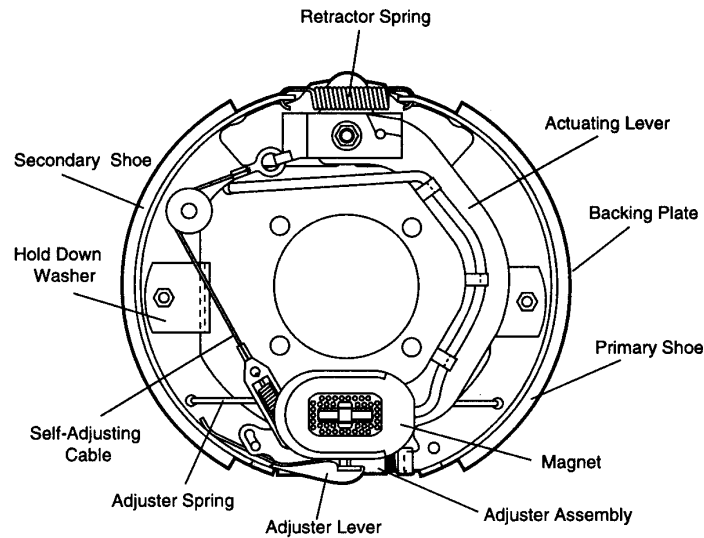

Figure 73. Electrical Brake Components

Hydraulic/Air/Surge Brakes

Hydraulic brakes (Figure 74) should not require any special attention with the exception of routine maintenance such as shoe and lining replacement. These brakes can be adjusted in the same manner as electric brakes. Brake lines should be periodically checked for cracks, kinks, or blockage.

Figure 73 below displays the major hydraulic/air/surge brake components that will require inspection and maintenance. Inspect these components as required using steps 1 through 6 as referenced in the electric brake adjustments section. Reference Table 16 on page 50 for hydraulic brake troubleshooting guidelines.

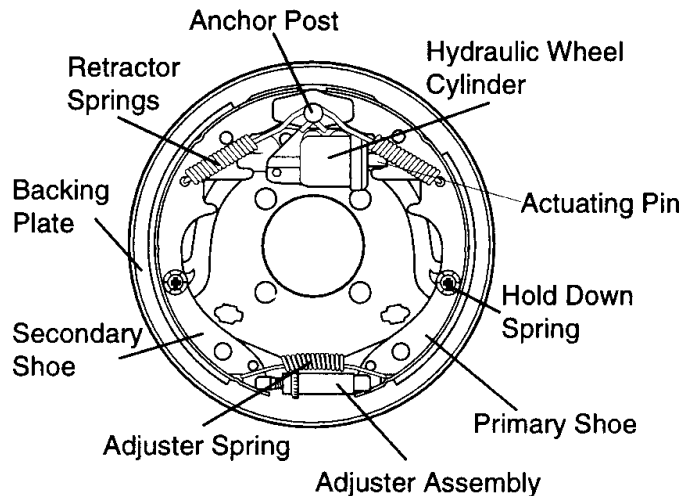

Figure 74. Hydraulic Brake Components

Tires/Wheels/Lug Nuts

Tires and wheels are a very important and critical components of the trailer. When specifying or replacing the trailer wheels it is important the wheels, tires, and axle are properly matched.

CAUTION:



DO NOT attempt to repair or modify a wheel. DO NOT install an inner tube to correct a leak through the rim. If the rim is cracked, the air pressure in the inner tube may cause pieces of the rim

to explode (break off) with great force and cause serious eye or bodily injury.

Tire Wear/Inflation

Tire inflation pressure is the most important factor in preserving tire life. Pressure should be checked cold before operation. **DO NOT** bleed air from tires when they are hot. Check inflation pressure weekly to insure the maximum tire life and to prevent premature tread wear. Table 12 (Tire Wear Troubleshooting) will help pinpoint the causes and solutions of tire wear problems.



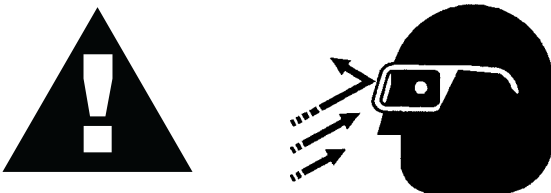



CAUTION:



NOTE

ALWAYS wear safety glasses when removing or installing force fitted parts. Failure to comply may result in serious injury.

TABLE 12. TIRE WEAR TROUBLESHOOTING

WEAR PATTERN		CAUSE	SOLUTION
	Center Wear	Over Inflation.	Adjust pressure to particular load per tire manufacturer.
	Edge Wear	Under Inflation.	Adjust pressure to particular load per tire manufacturer.
	Side Wear	Loss of chamber or overloading.	Make sure load does not exceed axle rating. Align wheels.
	Toe Wear	Incorrect toe-in.	Align wheels.
	Cupping	Out-of-balance.	Check bearing adjustment and balance tires.
	Flat Spots	Wheel lockup & tire skidding.	Avoid sudden stops when possible and adjust brakes.

Suspension

The leaf suspension springs and associated components (Figure 75) should be visually inspected every 6,000 miles for signs of excessive wear, elongation of bolt holes, and loosening of fasteners. Replace all damaged parts (suspension) immediately. Torqued suspension components as detailed in Table 13.

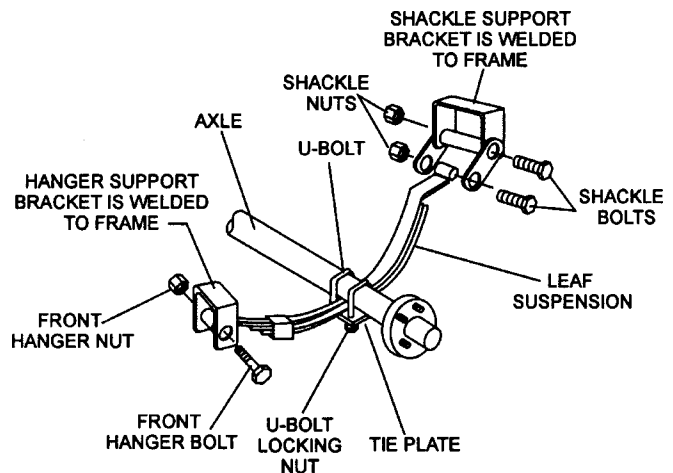

Figure 75. Suspension Components

DCA-125SSK — TRAILER TIRES & SUSPENSION

Table 13. Suspension Torque Requirements

Item	Torque (Ft.-Lbs.)
3/8" U-BOLT	MIN-30 MAX-35
7/16" U-BOLT	MIN-45 MAX-60
1/2" U-BOLT	MIN-45 MAX-60
SHACKLE BOLT SPRING EYE BOLT	SNUG FIT ONLY. PARTS MUST ROTATE FREELY. LOCKING NUTS OR COTTER PINS ARE PROVIDED TO RETAIN NUT-BOLT ASSEMBLY.
SHOULDER TYPE SHACKLE BOLT	MIN-30 MAX-50

Lug Nut Torque Requirements

It is extremely important to apply and maintain proper wheel mounting torque on the trailer. Be sure to use only the fasteners matched to the cone angle of the wheel. Proper procedure for attachment of the wheels is as follows:

1. Start all wheel lug nuts by hand.
2. Torque all lug nuts in sequence. See Figure 76. **DO NOT** torque the wheel lug nuts all the way down. Tighten each lug nut in 3 separate passes as defined by Table 14.
3. After first road use, retorque all lug nuts in sequence. Check all wheel lug nuts periodically for continued safe operation.

Table 14. Tire Torque Requirements

Wheel Size	First Pass FT-LBS	Second Pass FT-LBS	Third Pass FT-LBS
12"	20-25	35-40	50-65
13"	20-25	35-40	50-65
14"	20-25	50-60	90-120
15"	20-25	50-60	90-120
16"	20-25	50-60	90-120

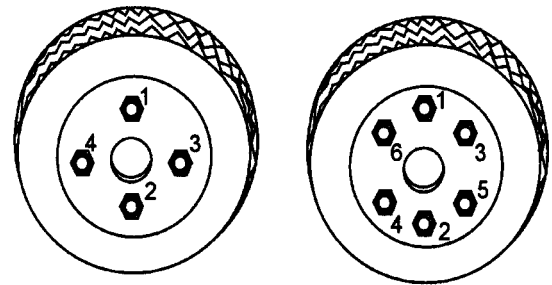

4-LUG NUTS

6-LUG NUTS

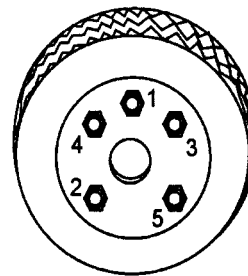

5-LUG NUTS

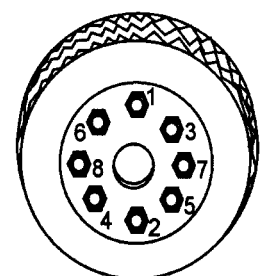

8-LUG NUTS

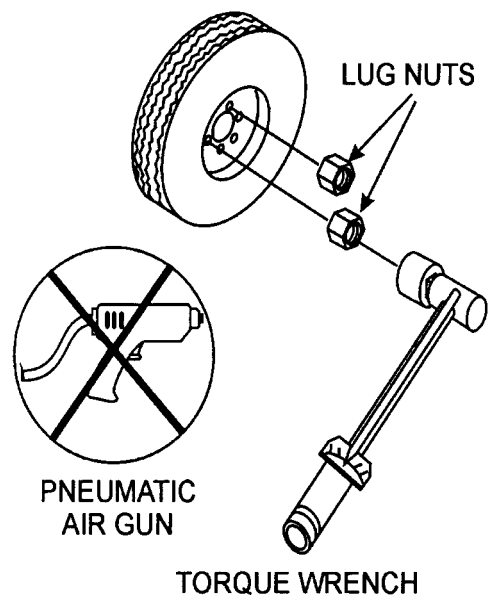

Figure 76. Lug Nut Tightening Sequence

NOTE

NEVER use an pneumatic air gun to tighten wheel lug nuts.

DCA-125SSK — TRAILER WIRING DIAGRAMS

TRAILER SIDE

TOWING VEHICLE SIDE

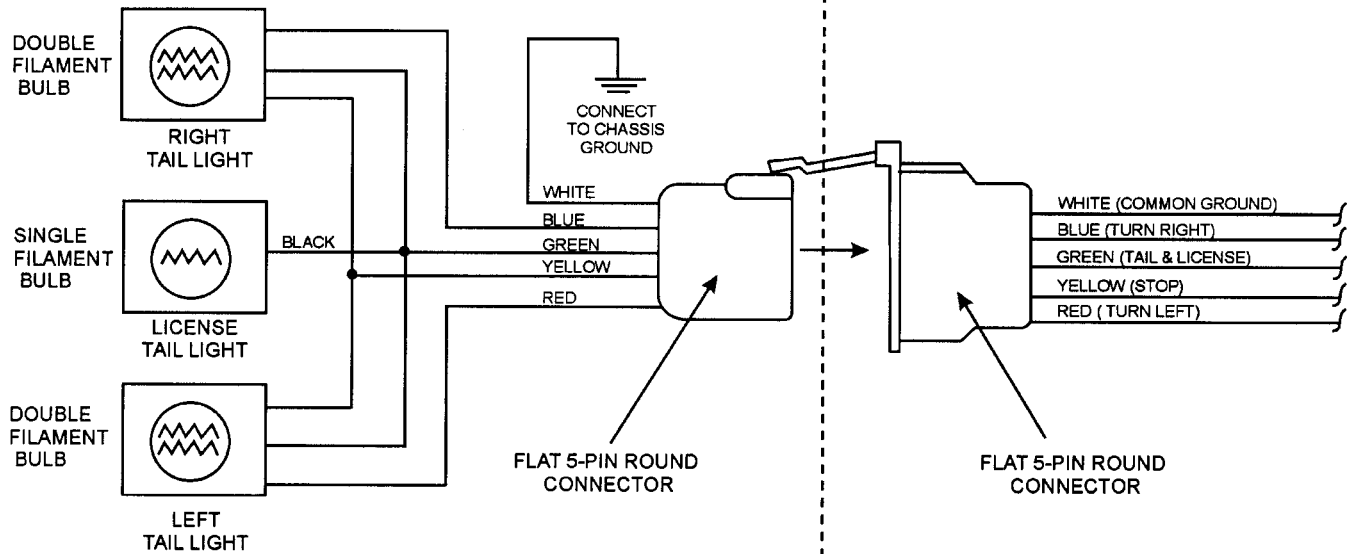
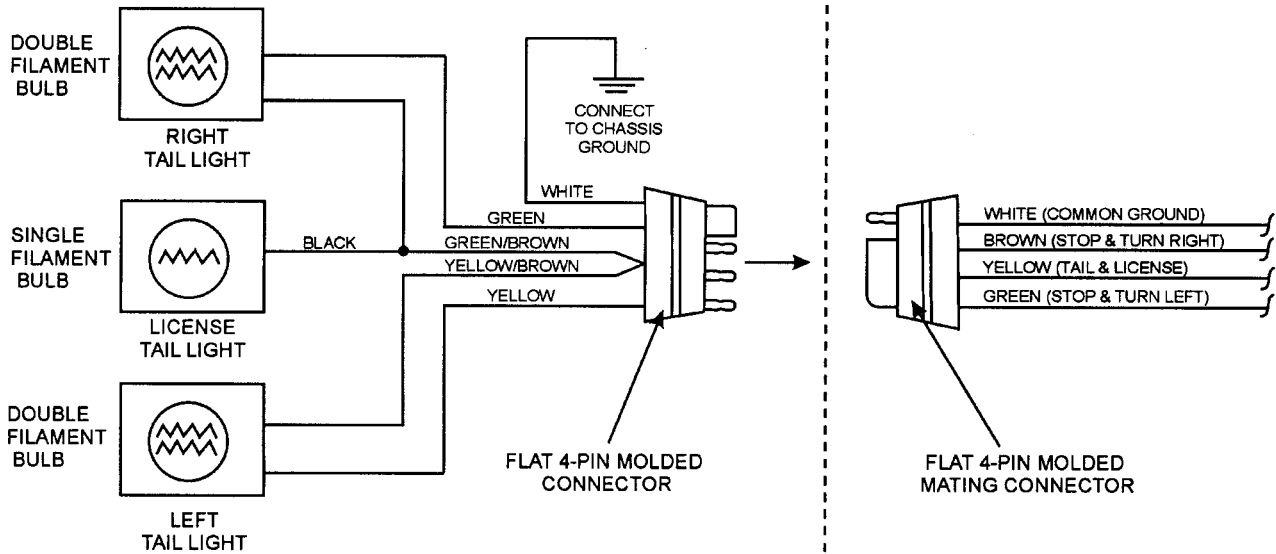

NOTE:
LIGHTS ARE ORIENTED FROM THE DRIVER'S SEAT

Table 15. Electric Brake Troubleshooting

Symptom	Possible Cause	Solution
No Brakes or Intermittent Brakes	Any open circuits or broken wires?	Find and correct.
	Any short circuits?	Find and correct.
	Faulty controller?	Test and correct.
	Any loose connections?	Find and repair.
	Ground wire secure?	Find and secure.
Weak Brakes or Brakes Pull to One Side	Grease or oil on magnets or linings?	Clean or replace.
	Connections corroded?	Clean and correct cause of corrosion.
	Brake drums scored or grooved?	Machine or replace.
	Brakes synchronized?	Correct.
Locking Brakes	Brake components loose, bent or broken?	Replace components.
	Brake drums out-of-round?	Replace.
Noisy Brakes	System lubricated?	Lubricate.
	Brake components correct?	Replace and correct.
Dragging Brakes	Bearings of the wheel adjusted?	Adjust.

Table 16. Hydraulic Brake Troubleshooting

Symptom	Possible Cause	Solution
No Brakes	Brake line broken or kinked?	Repair or replace.
Weak Brakes or Brakes Pull to One Side	Brake lining glazed?	Reburnish or replace.
	Trailer overloaded?	Correct weight.
	Brake drums scored or grooved?	Machine or replace.
	Tire pressure correct?	Inflate all tires equally.
	Tires unmatched on the same axle?	Match tires.
Locking Brakes	Brake components loose, bent or broken?	Replace components.
	Brake drums out-of-round?	Replace.
Noisy Brakes	System lubricated?	Lubricate.
	Brake components correct?	Replace and correct.
Dragging Brakes	Brake lining thickness correct or in right wrong position?	Install new shoes and linings.
	Enough brake fluid or correct fluid?	Replace rubber parts fill with dot4 fluid.

General Inspection

Prior to each use, the generating set should be cleaned and inspected for deficiencies. Check for loose, missing or damaged nuts, bolts or other fasteners. Also check for fuel or oil leaks.

Engine Side, Fuel, Oil and Coolant (Refer to the Engine Instruction Manual)

Air Cleaner

Every 50 hours: Remove air cleaner element and clean heavy duty paper element with kerosene, or foam element with liquid detergent and hot water. Wrap foam element in a cloth and squeeze dry. For heavy duty paper element, wipe excess kerosene with towel.

Fuel Addition

Add diesel fuel (the grade may vary according to season and locations). Always pour through the mesh filter.

Removing Water from the Tank

After prolonged use, water and other impurities accumulate in the bottom of the tank. Occasionally remove the drain cock and drain the contents. During cold weather, the greater the empty volume inside the tank, the easier it is for water to condense. This can be reduced by always keeping the tank as full as possible.

Air Removal

If air enters the fuel injection system of a diesel engine, starting becomes impossible. After running out of fuel, or after disassembling the fuel system, bleed the system according to the following procedure.

To restart after running out of fuel, turn the key switch to the "START" position for 15-30 seconds. Try again, if needed. This unit is equipped with an automatic air bleeding system.

Service Daily

If engine is operating in very dusty and dry grass conditions, a clogged air cleaner will result in high fuel consumption, loss of power and excessive carbon buildup in the combustion chamber.

Cleaning the Fuel Strainer

Clean the fuel strainer if it contains dust or water. Remove dust or water in the strainer cap and wash it in diesel. Securely fasten the fuel strainer cap so that fuel will not leak. Check the fuel strainer every 200 hours of operation or once a month.

Check Oil Level

Check the crankcase oil level prior to each use, or when the fuel tank is filled. Insufficient oil may cause severe damage to the engine. Make sure the generator is level. The oil level must be between the two notches on the dipstick as shown in Figure 9.

Generator Storage

For storage of the generator for over 30 days, the following is required:

- Drain the fuel tank completely.
- Run the engine until the fuel completely consumed.
- Completely drain the oil from the crankcase and refill with fresh oil.
- Stop the engine at the compression point.
- Clean all external parts of the generator with a cloth.
- Cover the generating set and store in a clean, dry place.

TABLE 17.

INSPECTION / MAINTENANCE		10 Hrs DAILY	250 Hrs	500 Hrs	1000 Hrs
ENGINE	Check Engine Fluid Levels	X			
	Check Air Cleaner	X			
	Check Battery Acid Level	X			
	Check Fan Belt Condition	X			
	Check for Leaks	X			
	Check for Loosening of Parts	X			
	Replace Engine Oil and Filter *1		X		
	Clean Air Filter		X		
	Drain Bottom of Fuel Tank		X		
	Clean Unit, Inside and Outside		X		
	Change Fuel Filter *2			X	
	Clean Radiator and Check Coolant Protection Level			X	
	Replace Air Filter Element				X
	Change Corrosion Resistor				X
	Check all Hoses and Clamps				X
Clean Inside of Fuel Tank				X	
GENERATOR	Measure Insulation Resistance Over 3M ohms		X		

*1 Replace engine oil and filter at 100 hours, first time only.

*2 Replace fuel filter at 250 Hours, first time only.

DCA-125SSK — TROUBLESHOOTING (ENGINE)

Practically all breakdowns can be prevented by proper handling and maintenance inspections, but in the event of a breakdown, use the tables shown for

diagnosis based on the Engine Troubleshooting (Table 7). If the problem cannot be remedied, consult our company's business office or service plant.

TABLE 18. ENGINE TROUBLESHOOTING

SYMPTOM	POSSIBLE PROBLEM	SOLUTION
Engine does not start.	No fuel?	Replenish fuel.
	Air in the fuel system?	Bleed system.
	Water in the fuel system?	Remove water from fuel tank.
	Fuel pipe clogged?	Clean fuel pipe.
	Fuel filter clogged?	Clean or change fuel filter.
	Excessively high viscosity of fuel or engine oil at low temperature?	Use the specified fuel or engine oil.
	Fuel with low cetane number?	Use the specified fuel.
	Fuel leak due to loose injection pipe retaining nut?	Tighten nut.
	Incorrect injection timing?	Adjust.
	Fuel cam shaft worn?	Replace.
	Injection nozzle clogged?	Clean injection nozzle.
	Injection pump malfunctioning?	Repair or replace.
	Seizure of crankshaft, camshaft, piston, cylinder liner or bearing?	Repair or replace.
	Compression leak from cylinder?	Replace head gasket, tighten cylinder head bolt, glow plug and nozzle holder.
	Improper valve timing?	Correct or replace timing gear.
Piston ring and liner worn?	Replace.	
Excessive valve clearance?	Adjust.	
Starter does not run.	Starter malfunctioning?	Repair or replace.
	Wiring disconnected?	Connect wiring.

TABLE 19. ENGINE TROUBLESHOOTING (CONTINUED)

SYMPTOM	POSSIBLE PROBLEM	SOLUTION
Engine revolution is not smooth.	Fuel filter clogged or dirty?	Clean or change.
	Air cleaner clogged?	Clean or change.
	Fuel leak due to loose injection pipe retaining nut?	Tighten nut.
	Injection pump malfunctioning?	Repair or replace.
	Incorrect nozzle opening pressure?	Adjust.
	Injection nozzle stuck or clogged?	Repair or replace.
	Fuel over flow pipe clogged?	Clean.
	Governor malfunctioning?	Repair.
Either white or blue exhaust gas is observed.	Excessive engine oil?	Reduce to the specified level.
	Piston ring and liner worn or stuck?	Repair or replace.
	Incorrect injection timing?	Adjust.
	Deficient compression?	Adjust top clearance.
Either black or dark gray exhaust gas is observed.	Overload?	Lessen the load.
	Low grade fuel used?	Use the specified fuel.
	Fuel filter clogged?	Clean or change.
	Air cleaner clogged?	Clean or change.
	Deficient nozzle injection?	Repair or replace the nozzle.
Deficient output.	Incorrect injection timing?	Adjust.
	Engine's moving parts seem to be seizing?	Repair or replace.
	Uneven fuel injection?	Repair or replace the injection pump.
	Deficient nozzle injection?	Repair or replace the nozzle.
	Compression leak?	Replace head gasket, tighten cylinder head bolt, glow plug and nozzle holder.

DCA-125SSK —TROUBLESHOOTING (GENERATOR/ENGINE)

Practically all breakdowns can be prevented by proper handling and maintenance inspections, but in the event of a breakdown, use the tables shown for

diagnosis based on the Engine and Radiator Troubleshooting (Table 20) and the MPEC Troubleshooting (Table 21). If the problem cannot be remedied, consult our company's business office or service plant.

TABLE 20. ENGINE & GENERATOR TROUBLESHOOTING

SYMPTOM	POSSIBLE PROBLEM	SOLUTION
Engine fails to start and starter does not rotated.	Dead battery?	Replace battery.
	Defective starter switch?	Replace switch.
	Fuse F5 burned out?	Replace fuse.
Engine fails to start and starter rotates.	Broken pre-heat circuit?	Check pre-heat circuit.
	No fuel?	Add fuel.
	Defective wiring?	Check wiring.
Engine starts and remains at low speed.	Clogged fuel strainer?	Clean or replace.
	Clogged air cleaner?	Clean or replace.
	Disconnected wiring?	Check and repair wiring.
Engine speed rises and no voltage is present in AC power source.	No voltage present in AC power source?	Replace rectifier (RE1).
	Defective rotor?	Replace rotor.
	Defective voltmeter?	Replace voltmeter.
	Disconnected wiring?	Check and repair wiring.
	Layer short-circuit in armature winding?	Replace armature.
Engine speed rises and AC power voltage is too low or cannot be used.	Defective circuit breaker (protector)?	Replace circuit breaker (protector).
	Layer short-circuit, broken wires in armature winding?	Repair or replace armature.
Engine speed rises and battery discharges too soon.	Defective engine regulator?	Replace regulator.
	Defective wiring?	Repair or replace wiring.
Engine speed rises and engine seems overloaded.	Defective alternator?	Repair or replace alternator.
	Damaged alternator bearing?	Replace alternator bearings.

TABLE 21. MPEC TROUBLESHOOTING

Symptom	Possible Cause	Solution
Low oil pressure light is on.	Low oil level?	Fill oil level.
	Oil pressure sending unit failure?	Replace oil pressure sending unit.
	Time delay malfunction in MPEC?	Refer to dealer.
	Wire shorted?	Inspect/repair wire.
Low coolant level light is on.	Low coolant level?	Fill coolant level.
	Sending unit failure?	Replace sending unit.
	Low battery voltage?	Replace/charge battery.
High coolant temperature light is on.	Fan belt tension incorrect?	Tighten/replace fan belt.
	Air flow is not circulation through radiator?	Clean/repair radiator grill.
	Doors open?	Close doors.
	Exhaust leaking?	Replace/repair gaskets or faulty part.
	Generator being overloaded?	Check/reduce load.
	Thermostat failure?	Replace thermostat.
	Air intake blocked?	Clear all air intakes.
Overcrank light is on.	Temperature switch failure?	Replace temperature switch.
	No or low Fuel?	Fill fuel level.
Overspeed light is on.	MPEC needs to be calibrated?	Refer to dealer.
	RPM engine speed too high?	Adjust RPM.
	Governor actuator needs to be adjusted?	Adjust governor actuator.
	Governor controller needs to be adjusted?	Adjust governor controller.
Loss of MPU light(s) or on.	MPEC needs to be calibrated?	Refer to dealer.
	Magnetic pick up out of adjustment?	Adjust magnetic pick up.
	Magnetic pick up dirty?	Clean magnetic pick up.

EXPLANATION OF CODE IN REMARKS COLUMN

How to read the marks and remarks used in this parts book.

Items Found In the “Remarks” Column

Serial Numbers-Where indicated, this indicates a serial number range (inclusive) where a particular part is used.

Model Number-Where indicated, this shows that the corresponding part is utilized only with this specific model number or model number variant.

Items Found In the “Items Number” Column

All parts with same symbol in the number column, *, #, +, %, or ■, belong to the same assembly or kit.

NOTE

If more than one of the same reference number is listed, the last one listed indicates newest (or latest) part available.

DCA-125SSK — SUGGESTED SPARE PARTS

DCA-125SSKW/KOMATSU S6D108E-2 ENGINE

1 to 5 Units

Qty.	P/N	Description
1	0601807346	CIRCUIT BREAKER
1	0601840073	RHEOSTAT (VOLTAGE REGULAR)
1	0601840121	KNOB FOR RHEOSTAT
2	0601812598	RECEPTACLE 530 EM
1	0601812565	RECTIFIER
3	0602041147	OIL FILTER CARTRIDGE
1	0810105004	FUEL TANK CAP
3	0602042146	FUEL FILTER CARTRIDGE
3	0602046338	ELEMENT, AIR INNER
1	6008155390	STARTER SWITCH
3	615	KEY, IGNITION
1	0602123087	WATER TEMPERATURE GAUGE
1	0602122037	OIL PRESSURE GAUGE
1	0602122251	OIL SHUTDOWN SENDING UNIT
1	0602123250	WATER TEMPERATURE SENDING UNIT
3	0601822034	RECEPTACLE, CS 6369 250V, 50 AMPS

DCA-125SSK—GENERATOR ASSY.

GENERATOR ASSY.

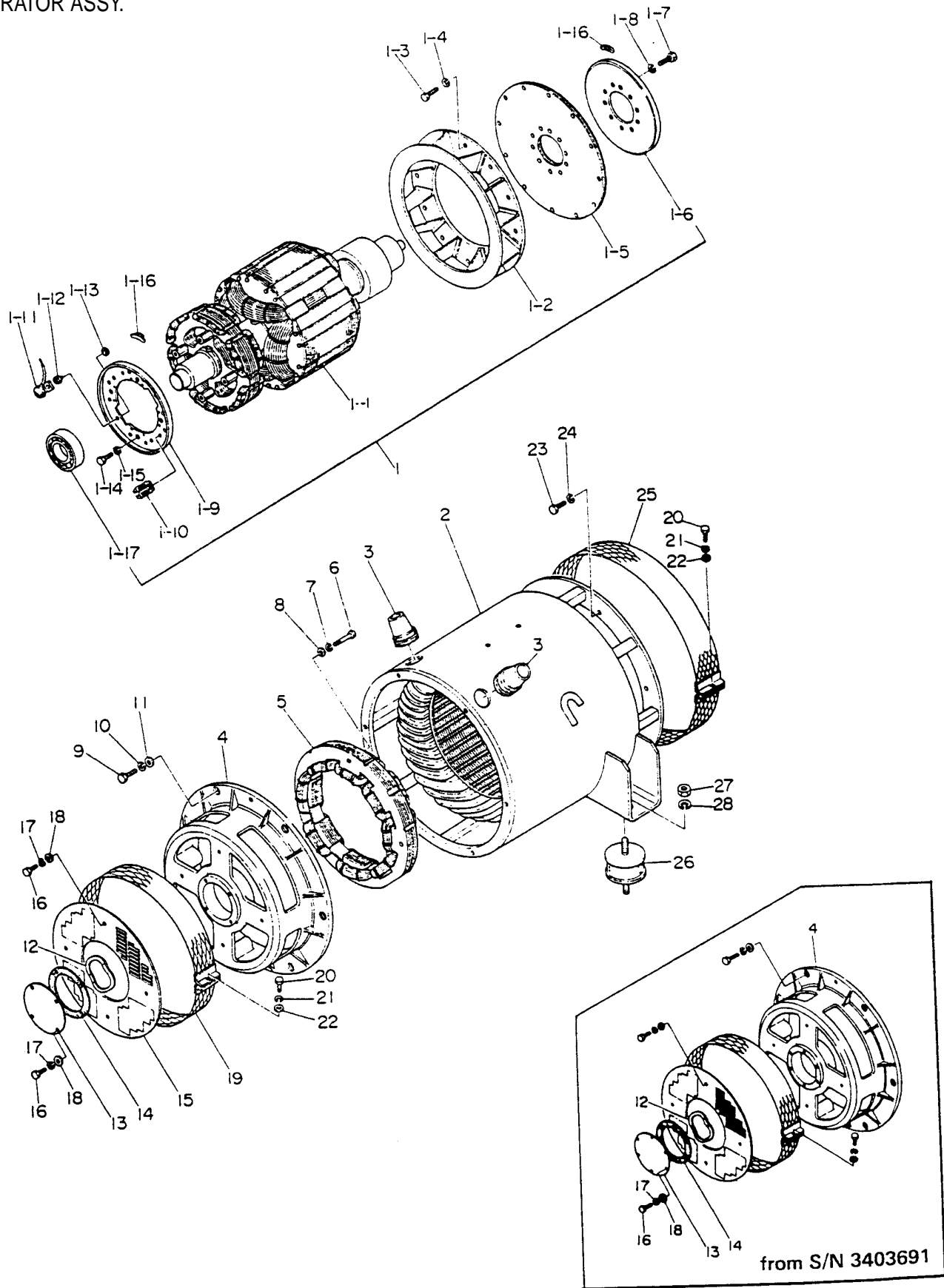

DCA-125SSK— GENERATOR ASSY.

GENERATOR ASSY.

<u>NO.</u>	<u>PART NO.</u>	<u>PART NAME</u>	<u>QTY.</u>	<u>REMARKS</u>
1	8131000032	ROTOR ASSY.	1	UP TO S/N3403690
	8131000042	ROTOR ASSY.	1	S/N3403700 TO S/N3404818
	8131000052	ROTOR ASSY.	1	S/N3404819 TO S/N3625799
	8131000062	ROTOR ASSY.	1	S/N3625800~
1-1		FIELD ASSY.		
1-2	8131070003	FAN	1	UP TO S/N3403749
	8131070013	FAN	1	FROM S/N3403750~
1-3	012010030	HEX.HEAD BOLT	12	REPLACES 0012110030
1-4	030210250	LOCK WASHER	12	REPLACES 0042510000
1-5	8131611004	COUPLING DISK	6	UP TO S/N3625799
1-8	8131611004	COUPLING DISK	8	FROM S/N3625800
1-6	8131015003	BALANCING PLATE	1	
1-7	0012112035	HEX. HEAD BOLT	10	
1-8	0042612000	LOCK WASHER	10	
1-9	8101026003	SET PLATE, RECTIFIER	1	UP TO S/N3404818
1-9	8101026013	SET PLATE, RECTIFIER	1	FROM S/N3404819
1-10	0601821349	RECTIFIER	2	FROM S/N3404819
1-11	0601822601	SURGE ABSORBER	1	ERZ14JK621A
1-12	8101020004	INSULATOR WASHER	1	UP TO S/N3404818
1-12	8001020004	INSULATOR WASHER	1	FROM S/N3404819
1-13	8001020504	INSULATOR WASHER	1	
1-14	0010110020	HEX. HEAD BOLT	4	
1-15	0040010000	LOCK WASHER	4	
1-16	0601000209	BALANCING WEIGHT KIT	1	5GX2 10GX2 15GX2 20GX2
1-17	0070206310	BEARING	1	6310RS UP TO S/N3403690
1-17	0070806311	BEARING	1	UP TO S/N3625799
1-17	0071906312	BEARING	1	FROM S/N3625800
2	8131340203	STRATOR ASSY.	1	UP TO S/N3404824
2	8131340213	STRATOR ASSY.	1	FROM S/N3600494
3	0845041804	GROMMET	2	
4	8131315002	END BRACKET	1	UP TO S/N3403690
4	8131315102	END BRACKET	1	UP TO S/N3625799
4	8131315202	END BRACKET	1	FROM S/N3625800
5	8101350013	FIELD ASSY. EXCITER	1	
6	0012110060	HEX. HEAD BOLT	4	
7	0042610000	LOCK WASHER	4	
8	0041610000	PLAIN WASHER	4	
9	0010112035	HEX. HEAD BOLT	6	
10	0040012000	LOCK WASHER	6	

DCA-125SSK—GENERATOR ASSY.

GENERATOR ASSY.

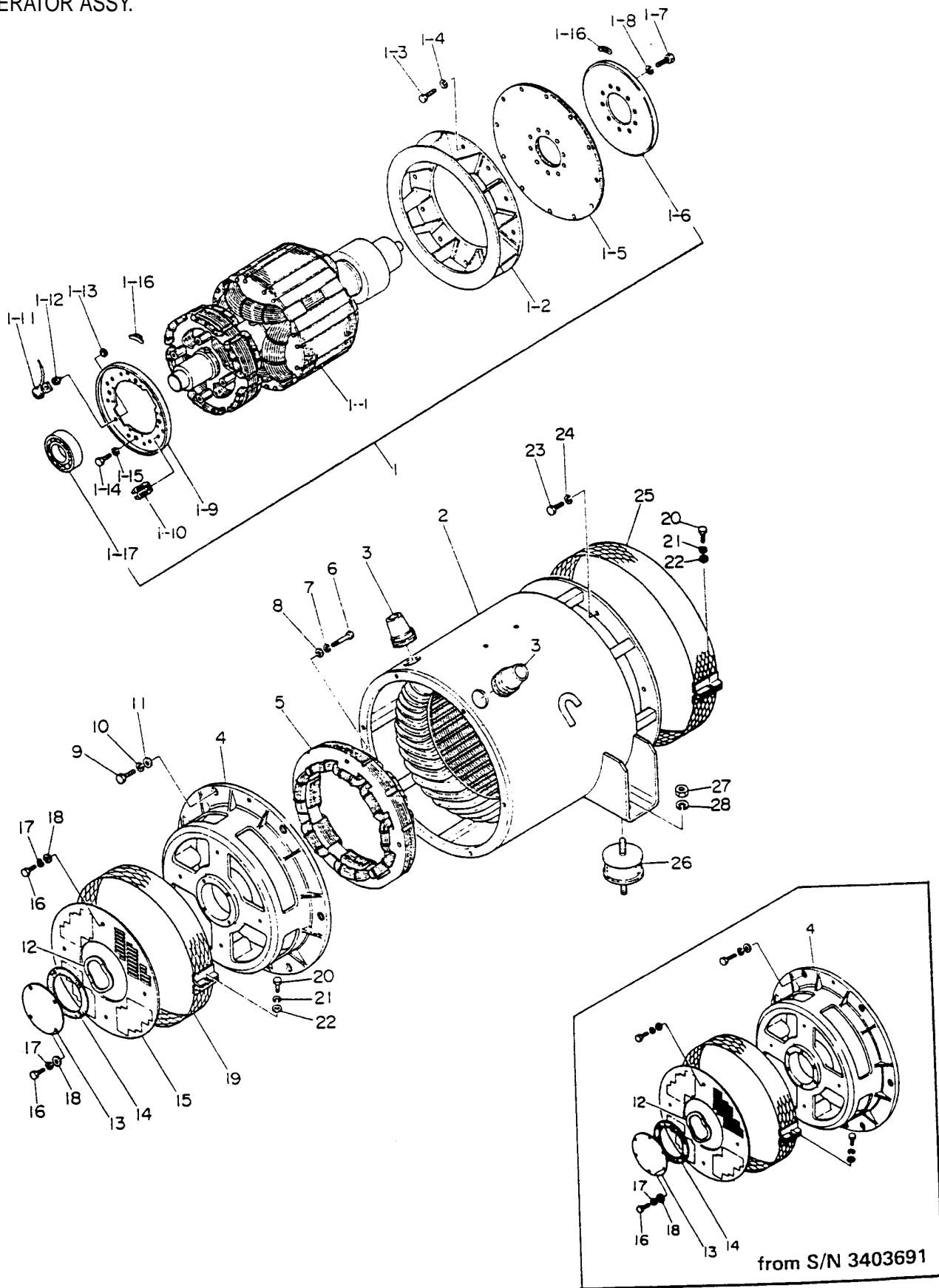

DCA-125SSK— GENERATOR ASSY.

GENERATOR ASSY.

<u>NO.</u>	<u>PART NO.</u>	<u>PART NAME</u>	<u>QTY.</u>	<u>REMARKS</u>
11	0041612000	PLAIN WASHER	6	
12	0601000004	WAVE WASHER	1	UP TO S/N3403690
12	0601000005	WAVER WASHER	1	UP TO S/N3625799
13	8101310004	COVER, BEARING	1	UP TO S/N3403690
13	8101310014	COVER, BEARING	1	UP/TO S/N3625799
13	8131310104	COVER, BEARING	1	FROM S/N3625800
14	8131312004	GASKET, BEARING	1	UP TO S/N3403690
14	8131312014	GASKET, BEARING	1	UP TO S/N3625799
14	8131312204	GASKET, BEARING	1	FROM S/N3625800
15	8101331003	COVER, END BRACKET	1	UP TO S/N3625799
18	8131331003	COVER, END BRACKET	1	FROM S/N3625800
16	0010106012	HEX. HEAD BOLT	8	UP TO S/N3403690
16	0010106012	HEX. HEAD BOLT	10	FROM S/N3403691
17	0040006000	LOCK WASHER	8	UP TO S/N3403690
17	0040006000	LOCK WASHER	10	FROM S/N3403691
18	0041606000	PLAIN WASHER	8	UP TO S/N3403690
18	0041606000	PLAIN WASHER	10	FROM S/N3403691
19	8101333003	COVER, END BRACKET	1	
20	0010106030	HEX. HEAD BOLT	2	
21	0040006000	LOCK WASHER	2	
22	0041606000	PLAIN WASHER	2	
23	0012110030	HEX. HEAD BOLT	12	
24	0042510000	LOCK WASHER	12	
25	8131332003	FAN COVER	1	
26	0605000063	RUBBER SUSPENSION	2	
27	0030016000	HEX. NUT	4	
28	0040016000	LOCK WASHER	4	

DCA-125SSK — CONTROL BOX ASSY.

CONTROL BOX ASSY.

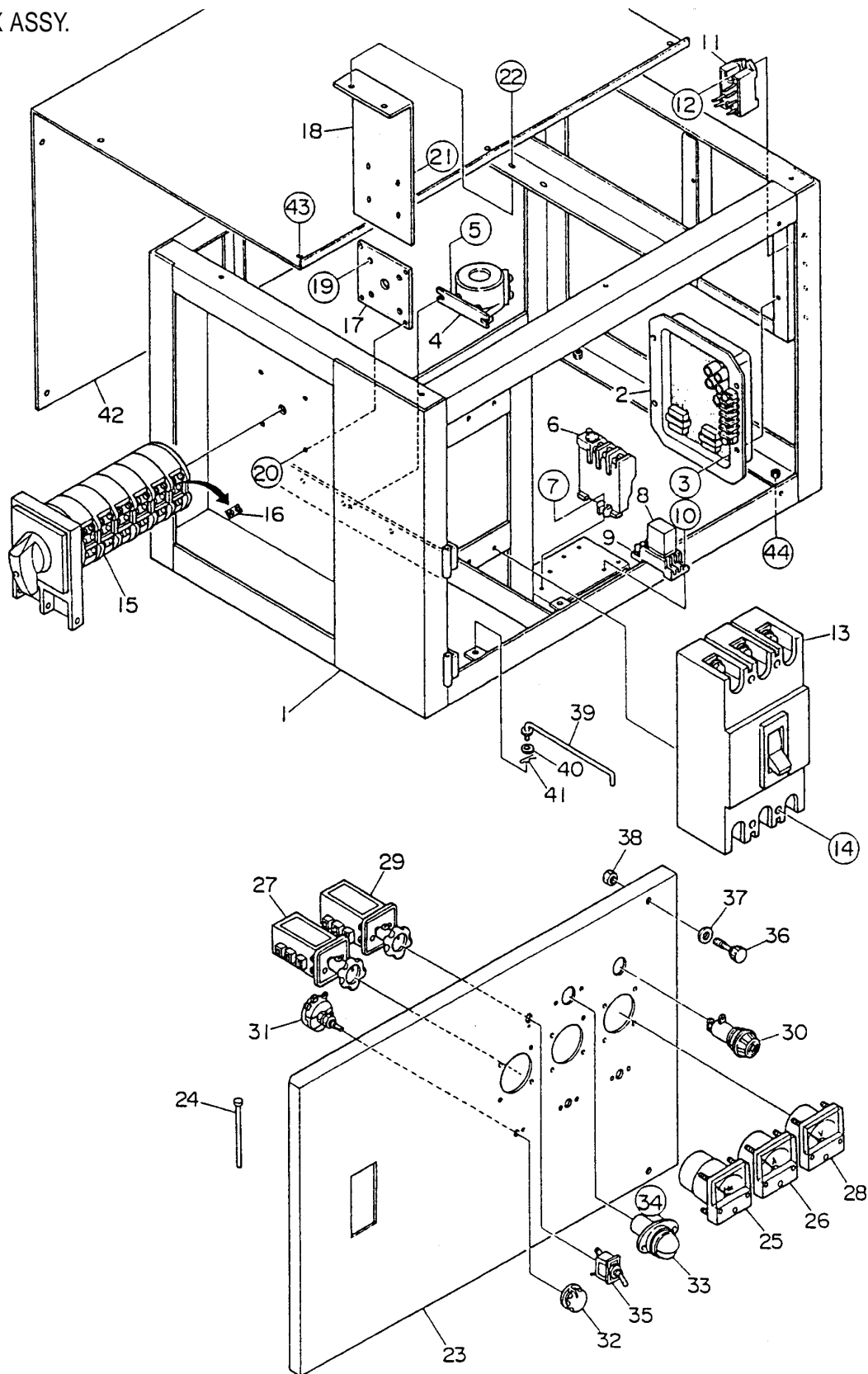

DCA-125SSK — CONTROL BOX ASSY.

CONTROL BOX ASSY.

<u>NO.</u>	<u>PART NO.</u>	<u>PART NAME</u>	<u>QTY.</u>	<u>REMARKS</u>
1	8131812612	CONTROL BOX	1	
2	0601820628	AUTOMATIC VOLTAGE REGULATOR	1	UP TO S/N3656097
2	0601820671	AUTOMATIC VOLTAGE REGULATOR	1	FROM S/N3656098
3	0027105012	MACHINE SCREW	4	
4	0601801147	CURRENT TRANSFORMER, AMMETER ...	2	CT3 5MS 250/5A
5	0027104010	MACHINE SCREW	4	
6	0601820851	OVER CURRENT RELAY	1	THK20
7	0027104015	MACHINE SCREW	2	
8	0601820903	RELAY	2	MY2 DC24V
9	0601823143	RELAY SOCKET	2	PYF08A
10	0021004015	MACHINE SCREW	4	
	0040004000	LOCK WASHER	4	
11	0601823860	RELAY UNIT	2	
12	0027204010	MACHINE SCREW	4	
13	0601804927	CIRCUIT BREAKER	1	UP TO S/N3652749
13	0601807345	CIRCUIT BREAKER;XE400NS300AT	1	FROM S/N3652750;
14	0021006045	MACHINE SCREW	4	
	0040006000	LOCK WASHER	4	
	0041606000	PLAIN WASHER	4	
15	8130153114	SELECTOR SWITCH	1	
16	8111839704	SPACER, SELECTOR SWITCH	1	FROM S/N3402597
17	8131839704	SET PLATE, SELECTOR SWITCH	1	
18	8131839514	BRACKET, SELECTOR SWITCH	1	
19	0021104010	MACHINE SCREW	4	
20	0021304015	MACHINE SCREW	4	
21	0021304010	MACHINE SCREW	4	
22	0017108020	HEX. HEAD BOLT	2	
23	8131820113	CONTROL PANEL	1	UP TO S/N3629115
23	8131820123	CONTROL PANEL	1	FROM S/N3629116 TO 3652749
23	8131820133	CONTROL PANEL	1	FROM S/N3652750
24	0605011211	PIN	2	
25	0601800460	FREQUENCY METER	1	PAK60 220 V 45165Hz
26	0601805718	AC AMMETER	1	PSK60 0~250A 0~500A

DCA-125SSK—CONTROL BOX ASSY.

CONTROL BOX ASSY.

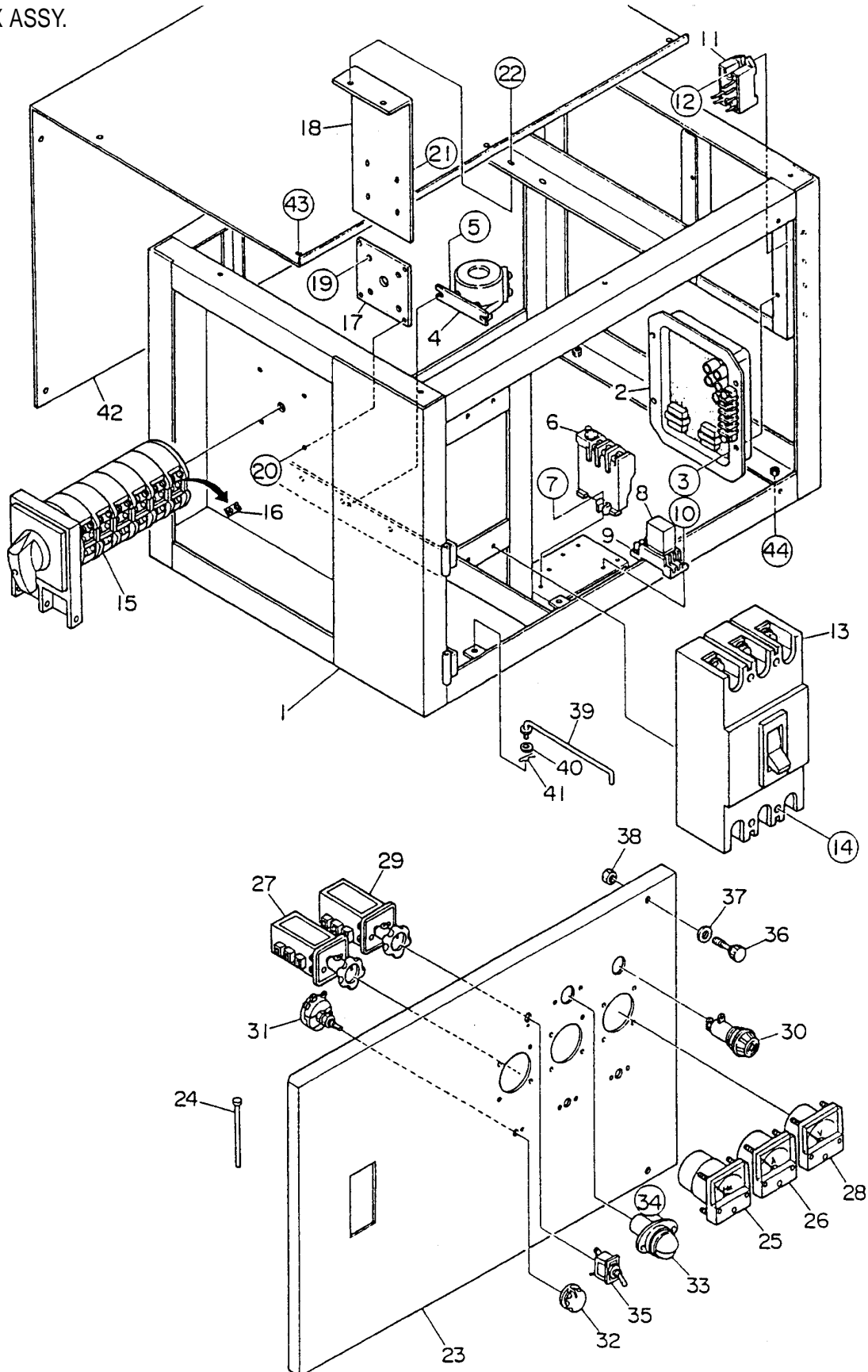

DCA-125SSK— CONTROL BOX ASSY.

CONTROL BOX ASSY. (CONT.)

<u>NO.</u>	<u>PART NO.</u>	<u>PART NAME</u>	<u>QTY.</u>	<u>REMARKS</u>
27	0601801040	CHANGE-OVER SW. AMMETER	1	SL2VS
28	0601800217	AC VOLTMETER	1	PCK60 0~600V
29	0601801041	CHANGE-OVER SW. VOLTMETER	1	SL2AS
30	0601810072	PILOT LAMP	1	LP132DC 220V
	0601810261	BULB	1	
31	0601840073	RHEOSTAT (VOLTAGE REGULATOR)	1	RA20A2SE102BJ
32	0601840121	KNOB	1	
33	0601810161	PANEL LIGHT	1	V325070
	0601810214	BULB	1	
34	0207004000	HEX. NUT	2	
35	0601830710	SWITCH, PANEL LIGHT	1	S301T
36	0805001304	SET SCREW	2	UP TO S/N3656097
36	0845056404	SET SCREW	2	FROM S/N3656098
37	0041608000	PLAIN WASHER	2	
38	0032008000	HEX. NUT	2	
39	3871824004	STOPPER, CONTROL PANEL	1	
40	0041606000	PLAIN WASHER	1	
41	0605010502	SNAP PIN	1	
42	8131811503	COVER, CONTROL BOX	1	
43	0017106016	HEX. HEAD BOLT	10	
44	0017108025	HEX. HEAD BOLT	4	
45	8111839904	MOUNT, SELECTOR SWITCH	1	
46	0207008000	HEX. NUT	2	

DCA-125SSK—ENGINE & RADIATOR ASSY.

ENGINE & RADIATOR ASSY.

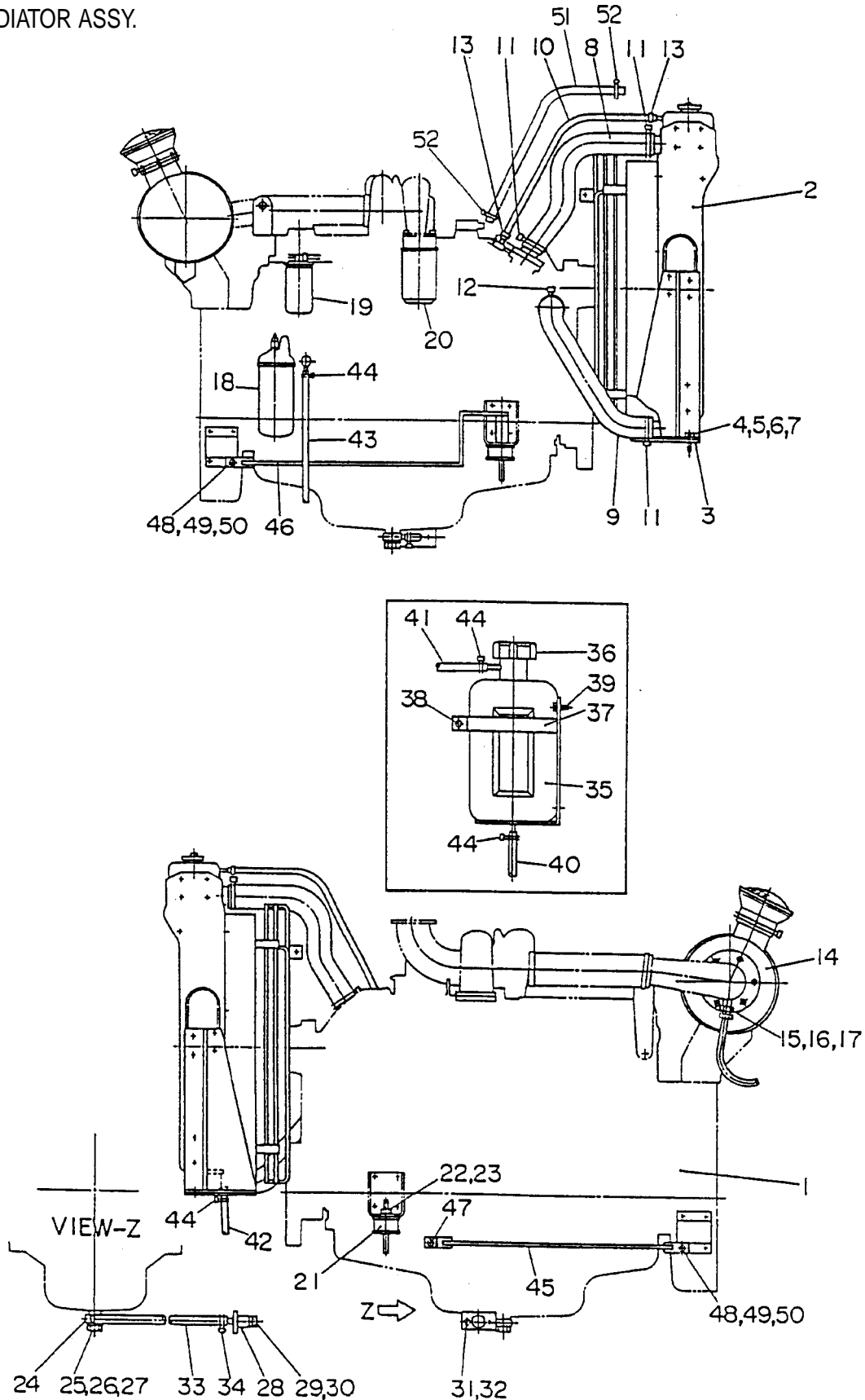

DCA-125SSK— ENGINE & RADIATOR ASSY.

ENGINE & RADIATOR ASSY.

<u>NO.</u>	<u>PART NO.</u>	<u>PART NAME</u>	<u>QTY.</u>	<u>REMARKS</u>
1	0602000151	ENGINE	1	KOMATSU S6D105 UP TO S/N3662598
1	8130150910	ENGINE	1	KOMATSU S6D105 FROM S/N3662599
2	0602011863	RADIATOR	1	6137619640
3	0605000095	RUBBER SHEET	2	6993619170
4	0010012045	HEX.HEAD BOLT	4	
5	0030012000	HEX. NUT	4	
6	0040012000	LOCK WASHER	4	
7	0041612000	PLAIN WASHER	4	
8	0602013078	RADIATOR HOSE	1	6993619181
9	0602013136	RADIATOR HOSE	1	6993619191
10	0602013079	RADIATOR HOSE	1	6128619530
11	0602014068	HOSE BAND	3	0728100709
12	0602014067	HOSE BAND	1	0728100809
13	0602014059	HOSE BAND	2	0728100167
14	0602040059	AIR CLEANER	1	6131827102
	0602040159	ELEMENT, AIR CLEANER	1	6131827011
15	0603300000	HALF UNION	1	
16	0603302000	SLEEVE	1	
17	0603303000	NUT	1	
18	0602041147	CARTRIDGE, OIL FILTER	1	6136515120
19	0602042149	CARTRIDGE, FUEL FILTER	1	6004111010
20	0602045148	ELEMENT, CORROSION RESISTOR ..	1	6004111010
21	0605000060	RUBBER SUSPENSION	2	
22	0030012000	HEX. NUT	4	
23	0040012000	LOCK WASHER	4	
24	0802010104	DRAIN JOINT	1	
25	0802024004	PACKING	1	OIL PAN SIDE
26	0805008004	PACKING	1	
27	0802025104	JOINT BOLT	1	
28	3862051003	DRAIN JOINT	1	
29	0802010204	PLUG	1	
30	0802024004	PACKING	1	
31	0017108025	HEX. HEAD BOLT	2	
32	0030008000	HEX. NUT	2	
33	8132052004	DRAIN HOSE	1	
34	0605515081	HOSE BAND	2	
35	0802081003	RESERVE TANK	1	
36	0602010900	CAP, RESERVE TANK	1	
	0225000600	RUBBER CUSHION	1	

DCA-125SSK—ENGINE & RADIATOR ASSY.

ENGINE & RADIATOR ASSY.

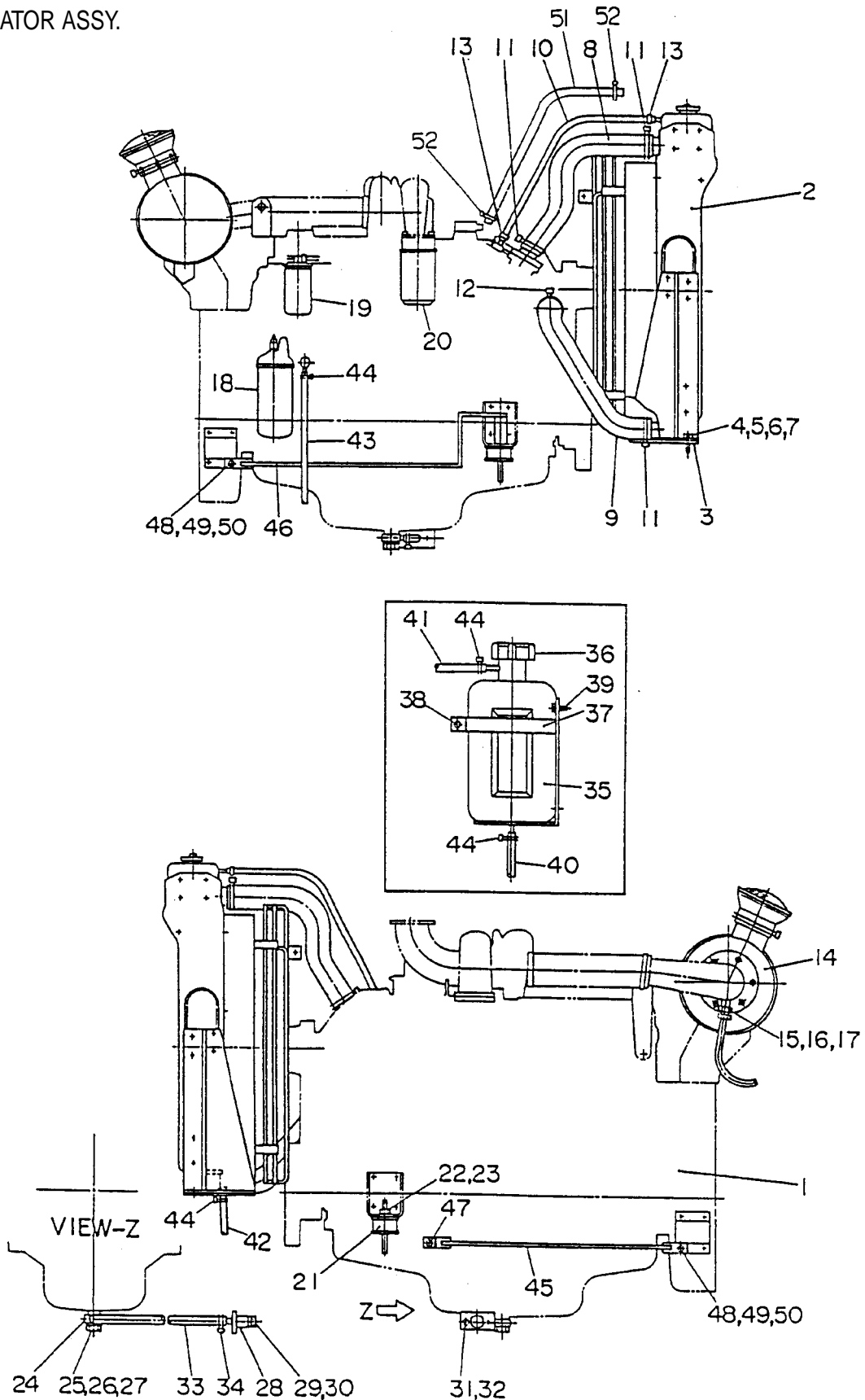

DCA-125SSK— ENGINE & RADIATOR ASSY.

ENGINE & RADIATOR ASSY. (CONT)

<u>NO.</u>	<u>PART NO.</u>	<u>PART NAME</u>	<u>QTY.</u>	<u>REMARKS</u>
38	0017106020	HEX. HEAD BOLT	1	
39	0017108020	HEX.HEAD BOLT	2	
40	0199502900	HOSE	1	
41	0193602000	HOSE	1	
42	0193600400	HOSE	1	
43	0193600800	HOSE	1	
44	0605515013	HOSE BAND	5	
45	8132256104	SUPPORT ROD	1	
46	7302256303	SUPPORT ROD	1	
47	0017110025	HEX. HEAD BOLT	1	
48	0010012025	HEX. HEAD BOLT	2	
49	0040012000	LOCK WASHER	2	
50	0041312000	PLAIN WASHER	3	
51	0268200850	BREATHER HOSE	1	FROM S/N3662599
52	0605515132	BAND	2	FROM S/N3662599

DCA-125SSK — ENGINE OPERATING PANEL ASSY.

ENGINE OPERATING PANEL ASSY.

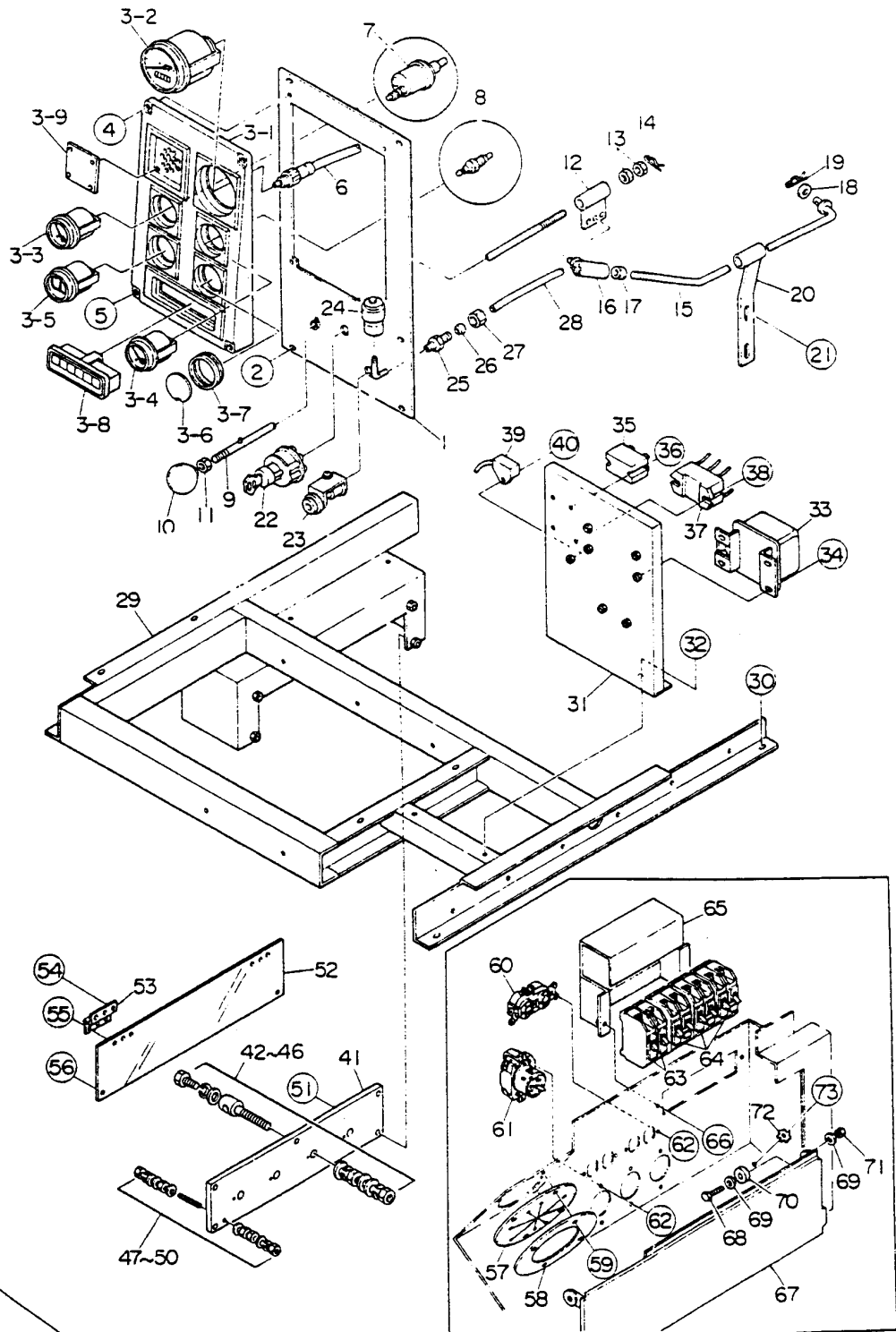

from S/N 3402611

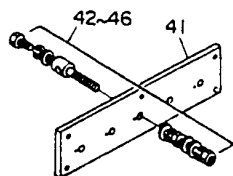

DCA-125SSK — ENGINE OPERATING PANEL ASSY.

ENGINE OPERATING PANEL ASSY.

<u>NO.</u>	<u>PART NO.</u>	<u>PART NAME</u>	<u>QTY.</u>	<u>REMARKS</u>
1	8132111203	OPERATING PANEL	1	
2	0017106020	HEX. HEAD BOLT	5	
3	0602120507	METER PANEL ASSY., V418150	1	UP TO S/N3609231
3	0602120518	METER PANEL ASSY.	1	FROM S/N3609232
3-1	0602120601	METER PANEL	1	
3-2	0602120071	TACHOMETER;V457370	1	UP TO S/N3609231
3-2	0602120073	TACHOMETER	1	FROM S/N3609232
3-3	0602122073	OIL PRESSURE GAUGE; V485310	1	UP TO S/N3609231
3-3	0602122076	OIL PRESSURE GAUGE	1	FROM S/N3609232
3-4	0602123073	WATER TEMPERATURE GAUGE; V495880	1	UP TO S/N3609231
3-4	0602123076	WATER TEMPERATURE GAUGE	1	FROM S/N3609232
3-5	0602121071	CHARGING AMMETER;V425130	1	
3-6	0602129014	COVER;V4181400300	1	
3-7	0602129012	GROMMET;V4179300200	1	
3-8	0602115010	INDICATOR ASSY.;V336840	1	
	0601810204	BULB	6	
3-9	0602129015	COVER;V4181400200	1	
4	0017106025	HEX. HEAD BOLT	2	
5	0010006050	HEX. HEAD BOLT	2	
	0040006000	LOCK WASHER	2	
	0041606000	PLAIN WASHER	2	
6	0845044104	CABLE, TACHOMETER	1	
7	0602122231	UNIT, OIL PRESSURE;V485290	1	
8	0602123231	UNIT, WATER TEMP.; V495810	1	
9	8132142004	SLIDE BAR	1	
10	0805012904	KNOB	1	
11	0036003000	HEX. NUT	1	
12	7452140504	BRACKET, GOVERNOR ROD	1	
13	0030008000	HEX. NUT	2	
14	0605010503	SNAP PIN	1	
15	8132152504	GOVERNOR ROD	1	
16	0602180101	BALL JOINT	1	
17	0030008000	HEX. NUT	1	
18	0041608000	PLAIN WASHER	1	
19	0605010503	SNAP PIN	1	
20	8132154504	ROD GUIDE	1	
21	0010012025	HEX. HEAD BOLT	1	
	0040012000	LOCK WASHER	1	
	0041612000	PLAIN WASHER	1	
22	0602100049	STARTER SWITCH;6008155390	1	
23	0602102047	PREHEAT LAMP;6008152371	1	
24	0602040690	INDICATOR, AIR CLEANER	1	
25	0603300000	HALF UNION	1	
26	0603302000	SLEEVE	1	
27	0603303000	NUT	1	
28	0190001500	NYLON PIPE	1	

DCA-125SSK — ENGINE OPERATING PANEL ASSY.

ENGINE OPERATING PANEL ASSY.

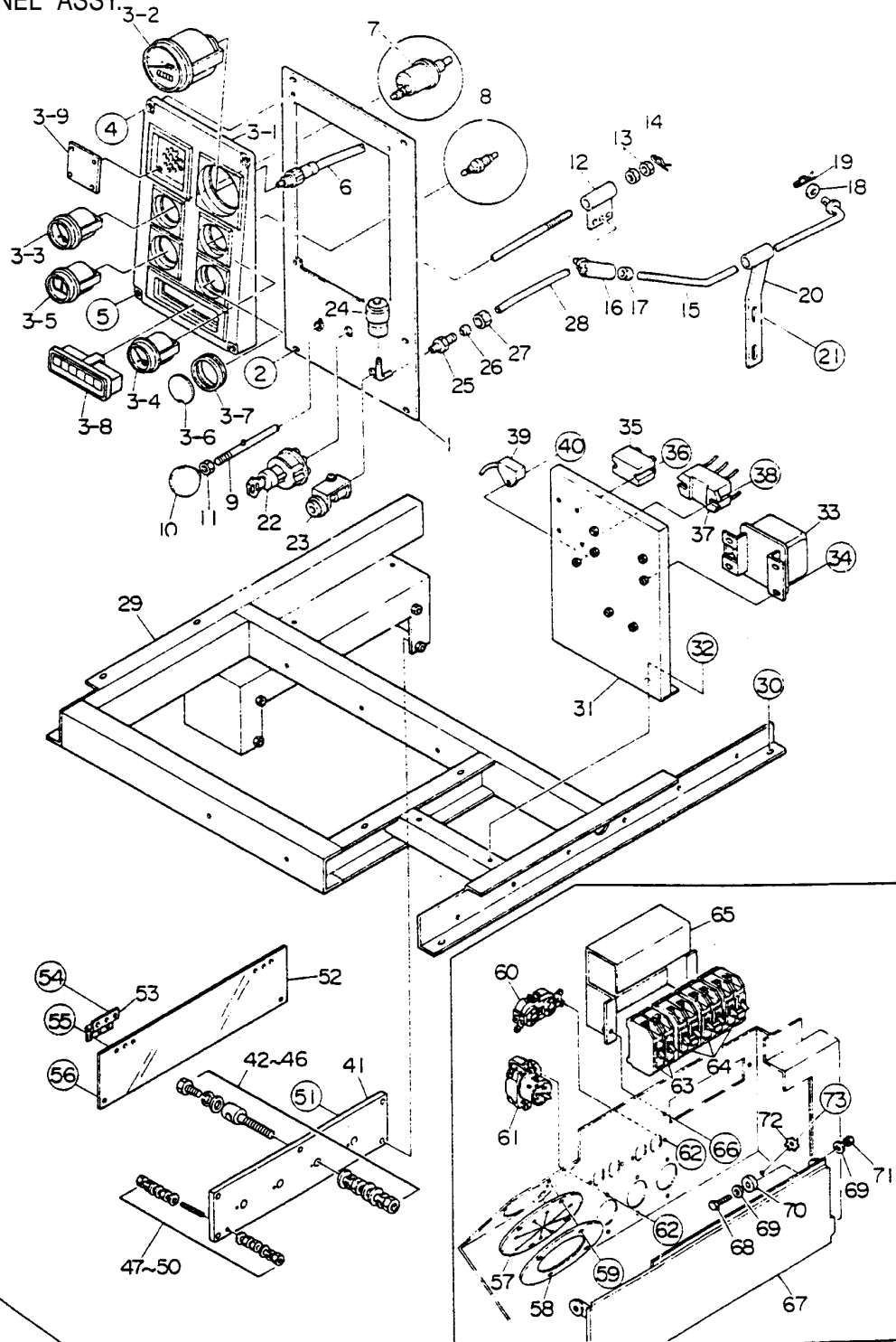

from S/N 3402611

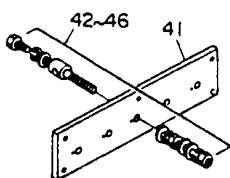

DCA-125SSK — ENGINE OPERATING PANEL ASSY.

ENGINE OPERATING PANEL ASSY. (CONT)

<u>NO.</u>	<u>PART NO.</u>	<u>PART NAME</u>	<u>QTY.</u>	<u>REMARKS</u>
29	8135312103	SUPPORT LEG	1	
30	0017110030	HEX. HEAD BOLT	4	
	020701000	HEX.NUT	4	
31	8151833103	BRACKET, ELECTRIC PARTS	1	
32	0071708020	HEX. HEAD BOLT	2	
33	0602200446	EMERGENCY RELAY;6008151252	1	
34	0017106020	HEX. HEAD BOLT	4	
35	0601823706	RELAY	1	
36	0027104010	MACHINE SCREW	2	
37	0601823861	ENGINE STOP UNIT	1	
38	0027104010	MACHINE SCREW	2	
39	0602201910	UNIT BATTERY SENSOR;D703900000	1	
40	0027106015	MACHINE SCREW	1	
41	8131860103	SET BOARD, OUTPUT TERMINAL	1.....	UP TO S/N3402610
41	8131860303	SET BOARD, OUTPUT TERMINAL	1.....	FROM S/N3402611
42	0801830304	OUTPUT TERMINAL	4.....	UP TO S/N3402610
42	0801830304	OUTPUT TERMINAL	5.....	FROM S/N3402611
43	0801830804	HEX. HEAD BOLT	4.....	UP TO S/N3402610
43	0801830804	HEX. HEAD BOLT	5.....	FROM S/N3402611
44	0041416000	PLAIN WASHER	16....	UP TO S/N3402610
44	0041416000	PLAIN WASHER	20....	FROM S/N3402611
45	0040016000	LOCK WASHER	12....	UP TO S/N3402610
45	0040016000	LOCK WASHER	15....	FROM S/N3402611
46	0039316000	HEX. NUT	8.....	UP TO S/N3402610
46	0039316000	HEX. NUT	10....	FROM S/N3402611
47	0801832304	TERMINAL SCREW	1.....	UP TO S/N3402610
48	0041406000	PLAIN WASHER	6.....	UP TO S/N3402610
49	0040006000	LOCK WASHER	2.....	UP TO S/N3402610
50	003930600	HEX.NUT	5.....	UP TO S/N3402610
51	0017108035	HEX. HEAD BOLT	5	
52	8131865704	COVER, OUTPUT TERMINAL	1	
53	0605010051	HINGE	2	
54	0027103010	MACHINE SCREW	6	
55	0027103015	MACHINE SCREW	6	
	0207003000	HEX. NUT	6	
56	0017106016	HEX. HEAD BOLT	2	
57	0845032104	RUBBER COVER	1	

DCA-125SSK — ENGINE OPERATING PANEL ASSY.

ENGINE OPERATING PANEL ASSY 3-2

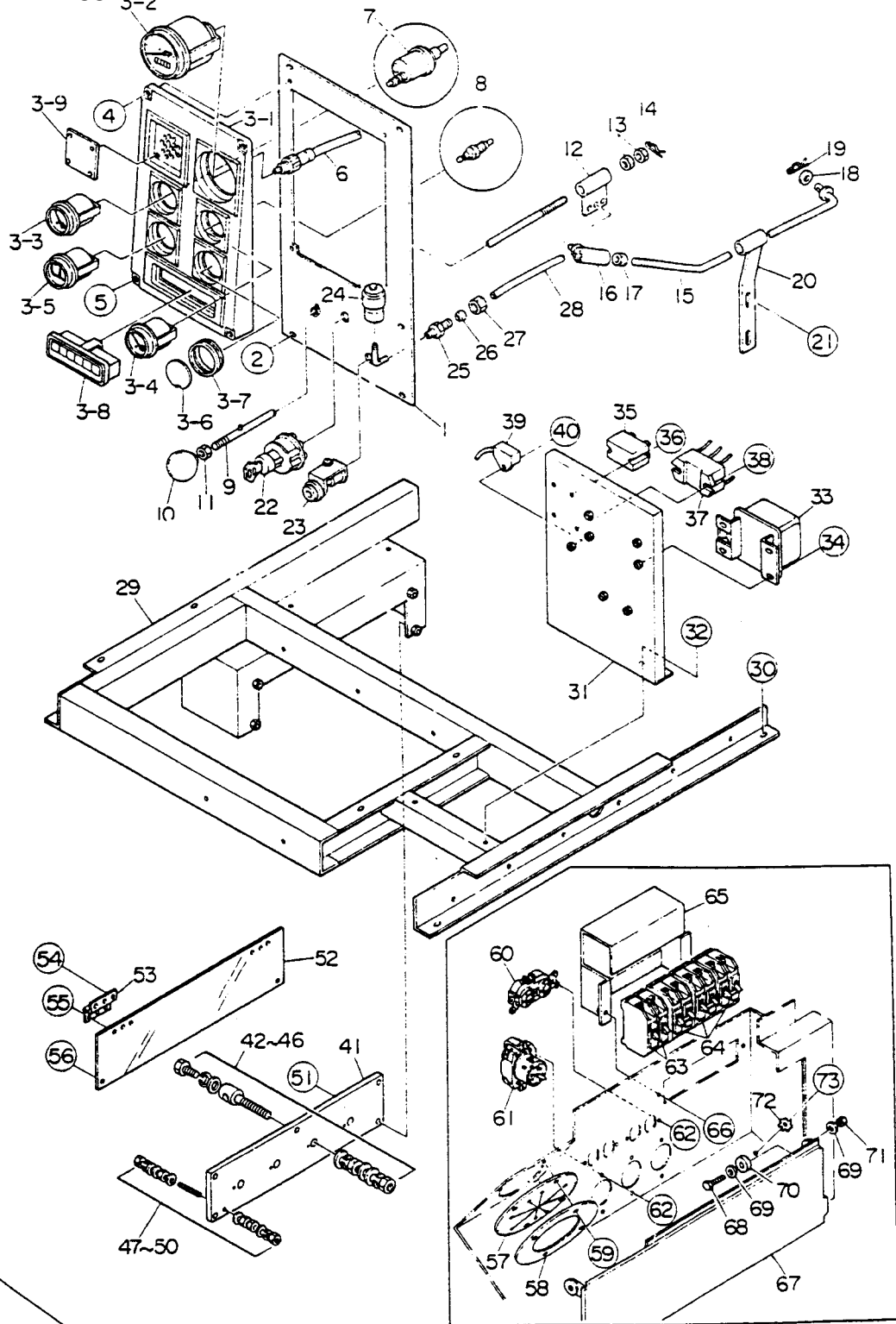

from S/N 3402611

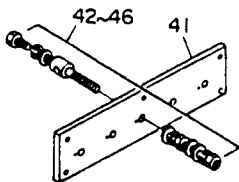

DCA-125SSK — ENGINE OPERATING PANEL ASSY.

ENGINE OPERATING PANEL ASSY. (CONT)

<u>NO.</u>	<u>PART NO.</u>	<u>PART NAME</u>	<u>QTY.</u>	<u>REMARKS</u>
59	0017110020	HEX. HEAD BOLT	4	
60	0601811030	RECEPTACLE;5-20R 125V 2A	2.....	UP TO S/N3627609
60	0601812598	RECEPTACLE;GF530EM	1.....	FROM S/N3627610
61	0601811034	RECEPTACLE;CS6369 250V 50A	3.....	UP TO S/N3656386
61	0601812565	RECEPTACLE;CS6369 250V 50A	3.....	FROM S/N3656387
62	0027103010	MACHINE SCREW	10	
	0041603000	PLAIN WASHER	10	
	0030003000	HEX. NUT	10	
63	0601805306	CIRCUIT BREAKER;KM51 265V 40A	2.....	UP TO S/N3627609
63	0601805313	CIRCUIT BREAKER;KM51 265 20A	2.....	FROM S/N3627610
64	0601805840	CIRCUIT BREAKER;KM52 265V 50A	3	
65	8131817103	BRACKET, CIRCUIT BREAKER	1	
	0223300200	RUBBER CUSHION	1	
66	0017106020	HEX. HEAD BOLT	2	
67	8131865303	COVER	1	
68	0010012045	HEX. HEAD BOLT	2	
69	0041612000	PLAIN WASHER	4	
70	0805009804	RUBBER WASHER	2	
71	0030012000	HEX. NUT	2	
72	0040506000	TOOTHED WASHER	1	
73	0017106020	HEX. HEAD BOLT	1	
	0601815500	TERMINAL	1	

DCA-125SSK — BATTERY ASSY.

BATTERY ASSY.

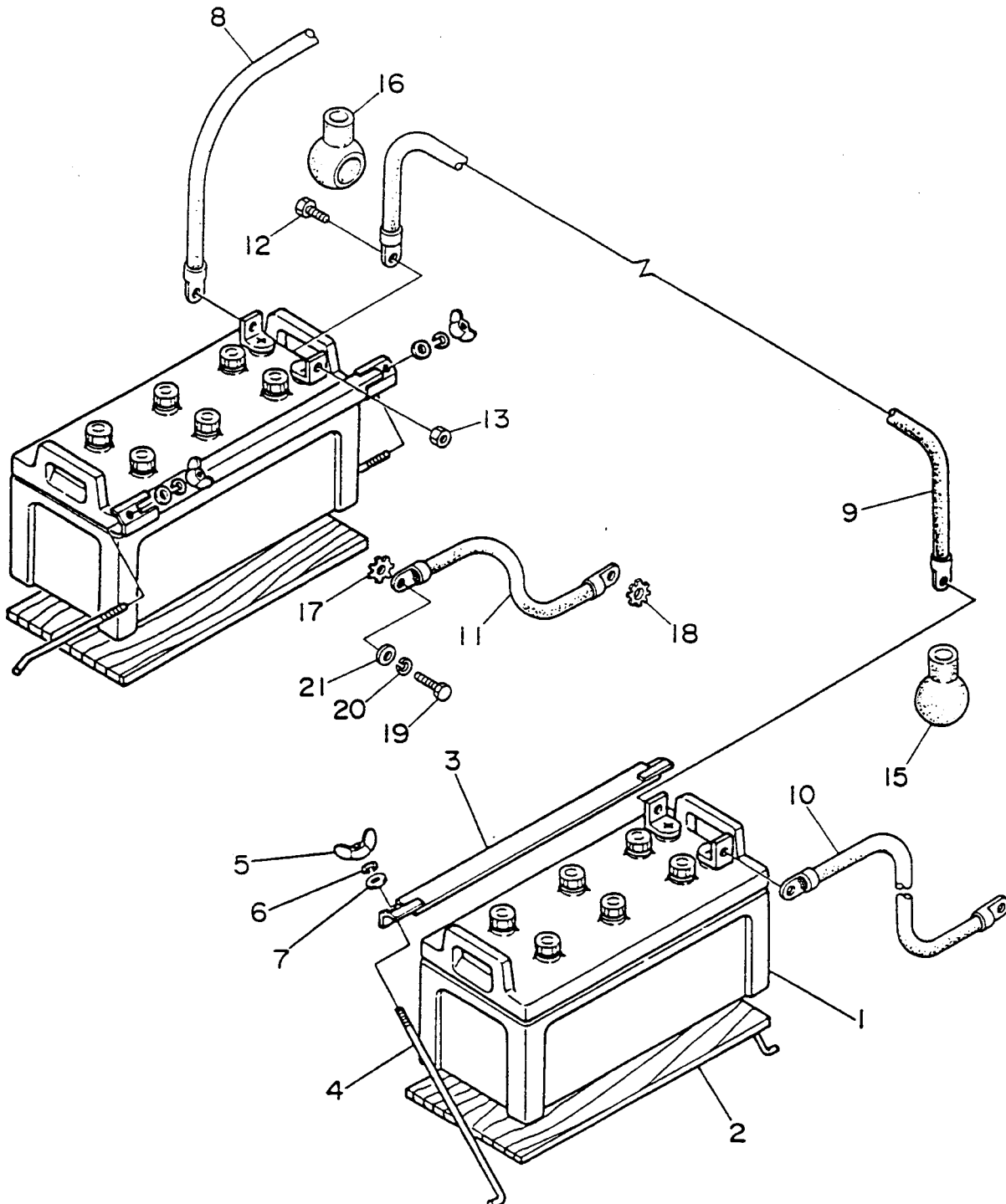
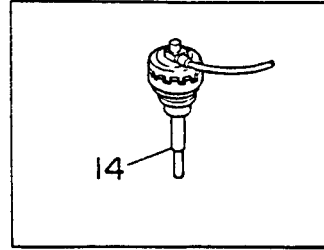

BATTERY ASSY.

<u>NO.</u>	<u>PART NO.</u>	<u>PART NAME</u>	<u>QTY.</u>	<u>REMARKS</u>
1	0165511551	BATTERY;115F511 12V-120Ah	2	
2	0805000804	BATTERY SHEET	2	
3	0805000904	BATTERY BAND	2	
4	0805002904	BATTERY BOLT	4	
5	0037808000	WING NUT	4	
6	0040008000	LOCK WASHER	4	
7	0041208000	PLAIN WASHER	4	REPLACES 0041208000
8	8132266104	BATTERY CABLE	1	
9	8132266304	BATTERY CABLE	1	
10	8132266504	BATTERY CABLE	1	
11	8132266704	EARTH CABLE	1	
12	012010030	HEX. HEAD BOLT	4	REPLACES 0010010030
13	020310080	HEX. NUT	4	REPLACES 0030010000
14	0602220203	BATTERY SENSOR	1	
15	0845040414	TERMINAL CAP	2	
16	0845041304	TERMINAL CAP	2	
17	0040512000	TOOTHED WASHER	1	
18	0040514000	TOOTHED WASHER	1	
19	0010012025	HEX. HEAD BOLT	1	
20	0040012000	LOCK WASHER	1	
21	0041612000	PLAIN WASHER	1	

DCA-125SSK — MUFFLER ASSY.

MUFFLER ASSY.

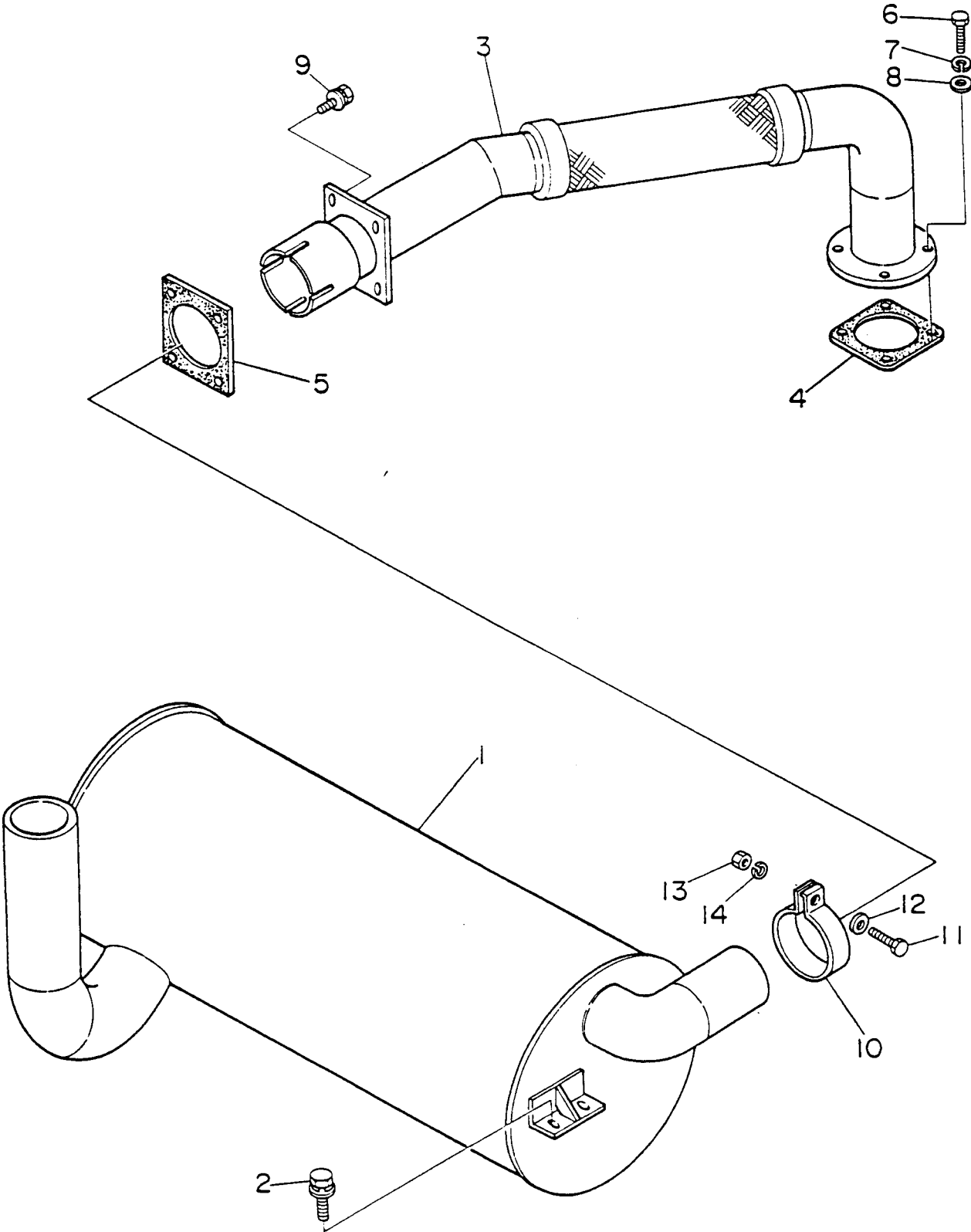

MUFFLER ASSY.

<u>NO.</u>	<u>PART NO.</u>	<u>PART NAME</u>	<u>QTY.</u>	<u>REMARKS</u>
1	7302311102	MUFFLER	1	
2	0017110030	HEX. HEAD BOLT	4	
3	7302350123	EXHAUST PIPE	1	
4	0602320049	GASKET;6138115860	1	
5	7302356204	GASKET	1	
6	0010310030	HEX. HEAD BOLT	4	
7	0040010000	LOCK WASHER	4	
8	0041610000	PLAIN WASHER	4	
9	0017108025	HEX. HEAD BOLT	4	
10	6182360004	PIPE BAND	1	
11	0010008030	HEX. HEAD BOLT	1	
12	0041608000	PLAIN WASHER	1	
13	0030008000	HEX. NUT	1	
14	0040008000	LOCK WASHER	1	

DCA-125SSK — FUEL TANK ASSY.

FUEL TANK ASSY.

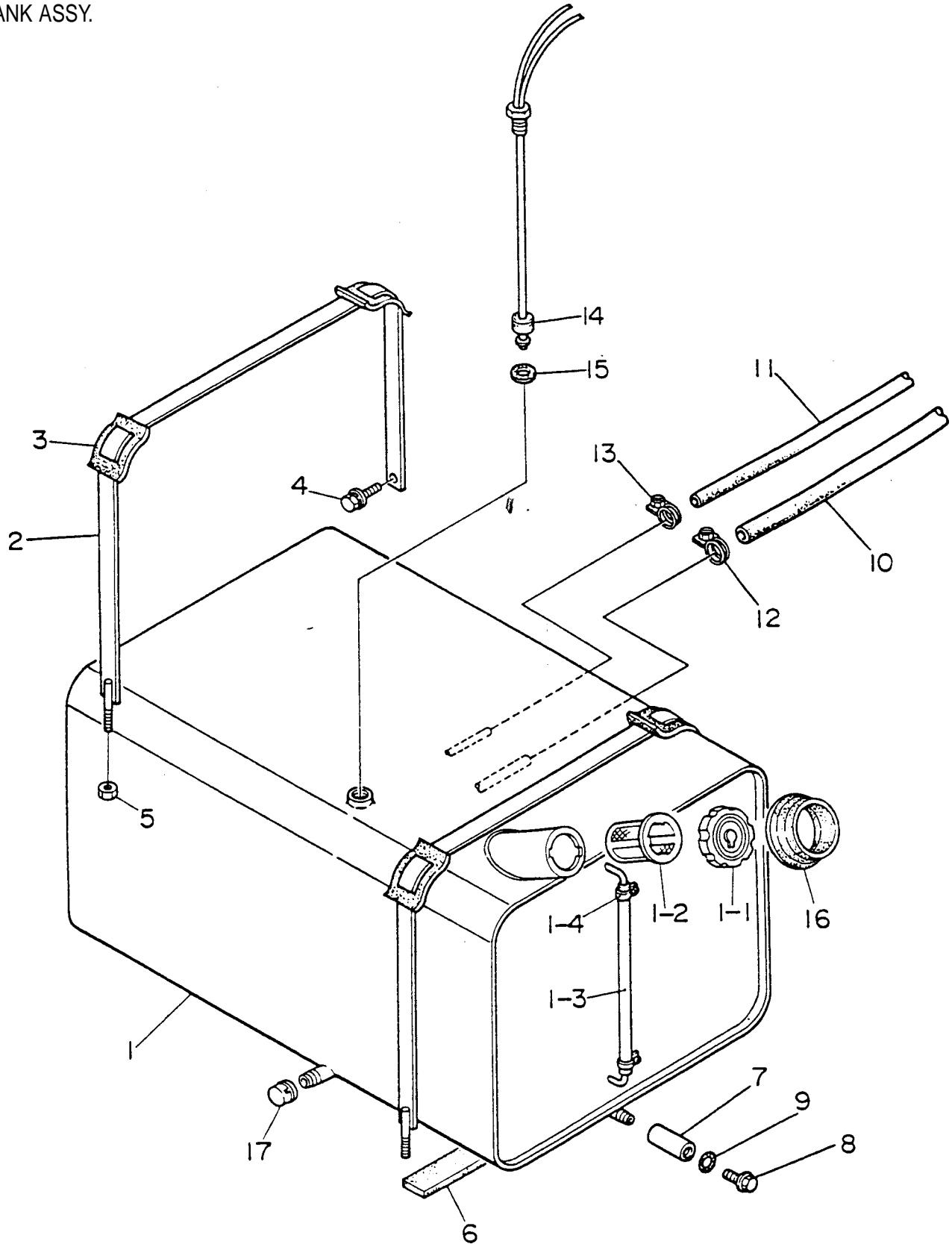

DCA-125SSK — FUEL TANK ASSY.

FUEL TANK ASSY.

<u>NO.</u>	<u>PART NO.</u>	<u>PART NAME</u>	<u>QTY.</u>	<u>REMARKS</u>
1	8135510503	FUEL TANK	1	
1-1	0605505030	CAP, FUEL TANK	1 WITH KEY
	0601850590	KEY, FUEL TANK	1	
1-2	0810105400	FUEL FILTER	1	
1-3	0193100450	FUEL GAUGE HOSE	1	
1-4	0605515079	HOSE BAND	2	
2	8135523114	TANK BAND	2	
3	0805003404	PAD, TANK BAND	4 UP TO S/N3656386
3	0805003414	PAD, TANK BAND	4 FROM S/N3656387
4	0017108020	HEX. HEAD BOLT	2	
5	0030008000	HEX. NUT	2	
6	0805013804	TANK SHEET	4 UP TO S/N3656386
6	0222100320	TANK SHEET	4 FROM S/N3656387
7	0845032204	DRAIN JOINT	1 UP TO S/N3656386
7	0845047504	DRAIN JOINT	1 FROM S/N3656387
8	0802011104	PLUG	1	
9	0150000018	O RING	1	
10	0191301270	SUCTION HOSE	1	
11	0191002300	RETURN HOSE	1	
12	0605515014	HOSE BAND	2	
13	0605515024	HOSE BAND	2	
14	0605503020	FUEL SENSOR	1	
15	0802120604	PACKING	1	
16	0845039604	RUBBER SEAL	1	
17	0131908000	CAP	1	

DCA-125SSK — ENCLOSURE ASSY.

ENCLOSURE ASSY. 9. Bonnet Ass'y

UP TO S/N3656386

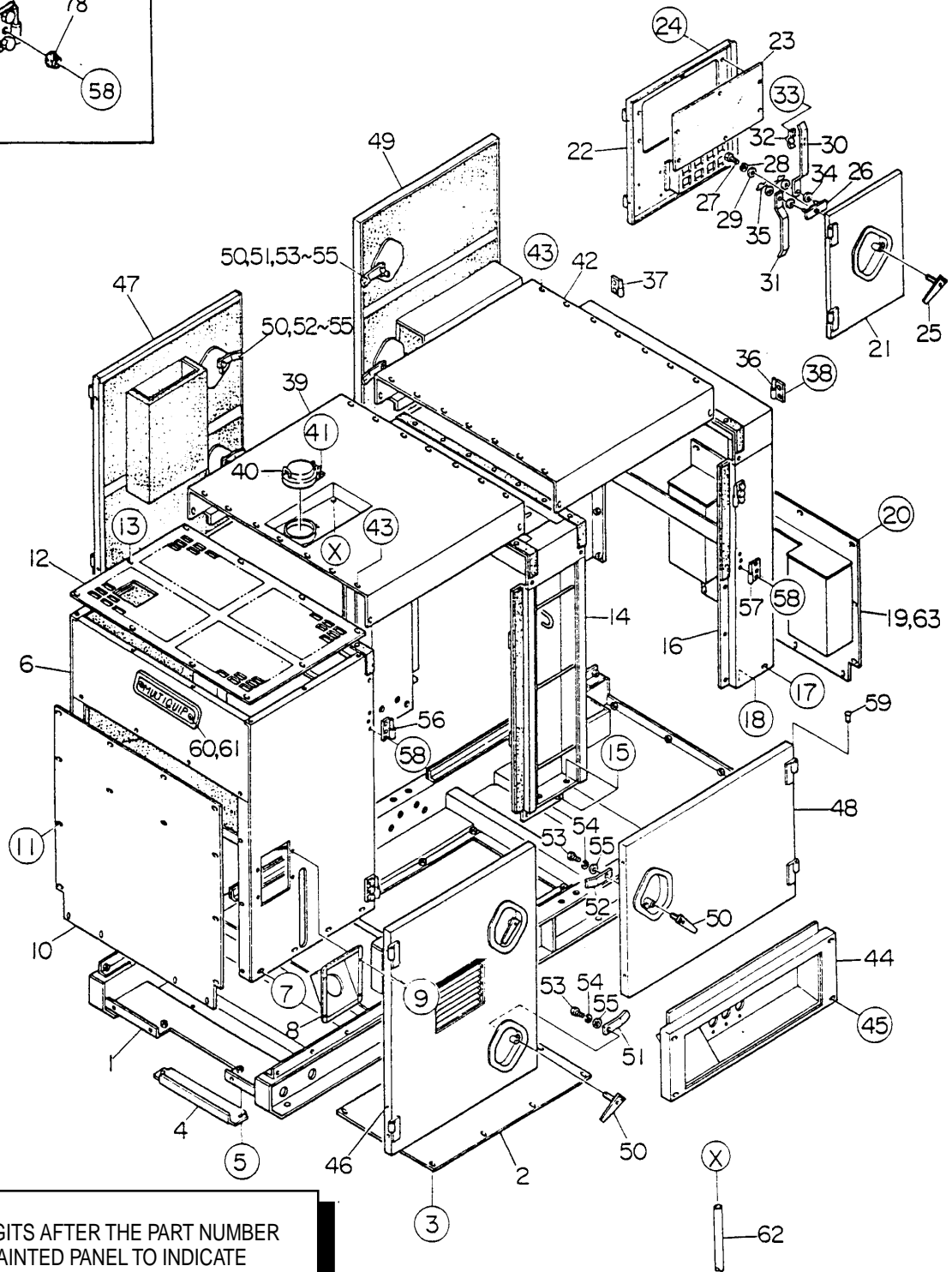
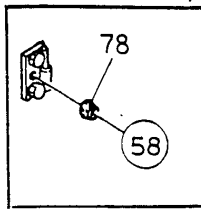

ADD THE FOLLOWING DIGITS AFTER THE PART NUMBER
WHEN ORDERING ANY PAINTED PANEL TO INDICATE
COLOR OF UNIT:

- | | |
|-----------------|----------------------|
| 1-ORANGE | 5-BLACK |
| 2-WHITE | 6-CATERPILLAR YELLOW |
| 3-SPECTRUM GRAY | 7-CATO GOLD |
| 4-SUNBELT GREEN | 8-RED |

THE SERIAL NUMBER MAY BE REQUIRED.

DCA-125SSK — ENCLOSURE ASSY.

ENCLOSURE ASSY. UP TO S/N3656386

<u>NO.</u>	<u>PART NO.</u>	<u>PART NAME</u>	<u>QTY.</u>	<u>REMARKS</u>
1	8135111202	BASE	1	
2	7305116204	FLOOR PANEL	1	
3	0017108002	HEX. HEAD BOLT	10	
4	8135116004	COVER	1	
5	0017108020	HEX. HEAD BOLT	2	
6	8135121202	FRONT FRAME		
	8135102103	LINING	1	
7	0017110025	HEX. HEAD BOLT	4	
8	0845039703	FILLER BRACKET	1	
9	0017108020	HEX. HEAD BOLT	4	
10	8135125104	COVER, FRONT FRAME	1	
	8135102204	LINING	1	
11	0017108020	HEX. HEAD BOLT	16	
12	7305125003	COVER, FRONT FRAME	1	
13	0017108020	HEX. HEAD BOLT	10	
14	8135131202	CENTER FRAME	1	
15	0010014045	HEX. HEAD BOLT	12	
	0030014000	HEX. NUT	12	
	0040014000	LOCK WASHER	12	
	0041614000	PLAIN WASHER	12	
16	8135141302	REAR FRAME	1	
17	0017110025	HEX. HEAD BOLT	2	
18	0017108020	HEX. HEAD BOLT	2	
19	8135155203	COVER, REAR FRAME	1	
20	0017108020	HEX. HEAD BOLT	12	
21	8135143403	DOOR, REAR FRAME	1	
22	8135143503	DOOR, REAR FRAME	1	
24	0027106020	MACHINE SCREW	6	
	0207006000	HEX. NUT	6	
25	0845033304	DOOR HANDLE	1	
26	0845042904	LINK, DOOR ROD	1	
27	0019108020	HEX. HEAD BOLT	1	
28	0042308000	LOCK WASHER	1	
29	0042408000	PLAIN WASHER	1	
30	3475146004	DOOR ROD	1	
31	8135146004	DOOR ROD	1	
32	0805011404	SPRING	1	
33	0027104010	MACHINE SCREW	2	
34	0041610000	PLAIN WASHER	4	
35	0605010504	SNAP PIN	2	
36	0845028203	HINGE	2	
37	0845028303	HINGE	2	
39	8135161002	ROOF PANEL	1	
40	0800251201	FILTER COVER	1	

DCA-125SSK — ENCLOSURE ASSY.

ENCLOSURE ASSY. UP TO S/N3656386

<u>NO.</u>	<u>PART NO.</u>	<u>PART NAME</u>	<u>QTY.</u>	<u>REMARKS</u>
41	0027106016	MACHINE SCREW.....	2	UP TO S/N3662598
42	8135161103	ROOF PANEL	1	
43	0017108020	HEX. HEAD BOLT	36	
44	8135181302	SPLASHER PANEL.....	1	UP TO S/N3627609
45	0010008065	HEX. HEAD BOLT	4	
	0040008000	LOCK WASHER	4	
	0041608000	PLAIN WASHER	4	
46	8135171703	SIDE DOOR	1	
	8135102513	LINING	1	
47	8135171603	SIDE DOOR	1	
	8135102413	LINING	1	
48	8135171503	SIDE DOOR	1	
	8135102704	LINING	1	
49	8135171803	SIDE DOOR	1	
	8135102603	LINING	1	
50	0845033304	DOOR HANDLE	7	
51	0845034204	DOOR LATCH	4	
52	0845034104	DOOR LATCH	3	
53	0019108020	HEX. HEAD BOLT	7	
54	0042308000	LOCK WASHER	7	
55	0042408000	PLAIN WASHER	7	
56	0810009103	HINGE	4	
57	0810009203	HINGE	4	
58	0017108020	HEX. HEAD BOLT	24	
59	0845031504	CAP	12	
60	6360510003	EMBLEM	2	
61	0021106020	MACHINE SCREW	4	
62	0194500900	HOSE	1	
63	0840625902	STICKER	1	

ADD THE FOLLOWING DIGITS AFTER THE PART NUMBER
WHEN ORDERING ANY PAINTED PANEL TO INDICATE
COLOR OF UNIT:

1-ORANGE	5-BLACK
2-WHITE	6-CATERPILLAR YELLOW
3-SPECTRUM GRAY	7-CATO GOLD
4-SUNBELT GREEN	8-RED

THE SERIAL NUMBER MAY BE REQUIRED.

DCA-125SSK — ENCLOSURE ASSY.

ENCLOSURE ASSY.

FROM S/N3656387

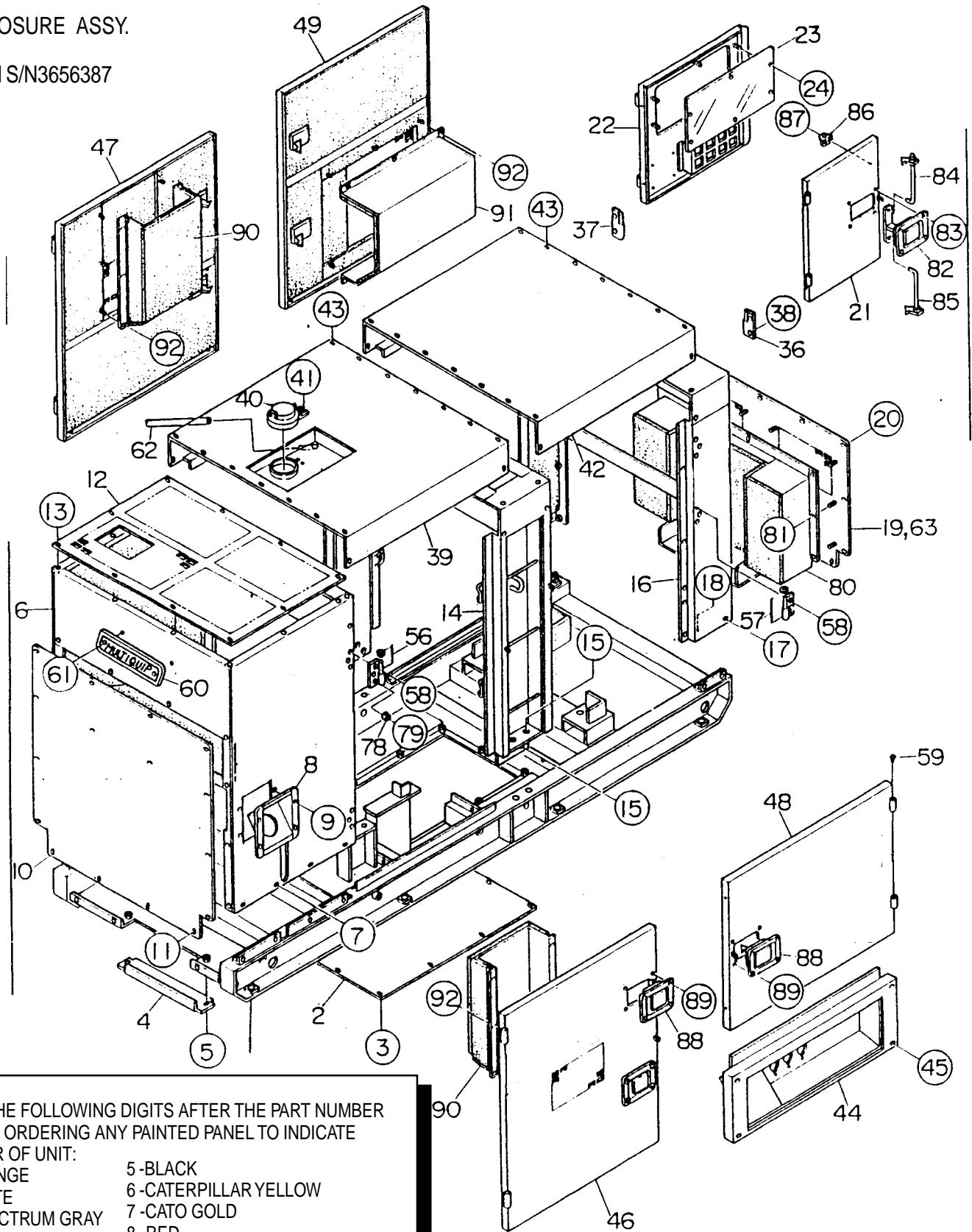

ADD THE FOLLOWING DIGITS AFTER THE PART NUMBER WHEN ORDERING ANY PAINTED PANEL TO INDICATE COLOR OF UNIT:

- | | |
|-----------------|----------------------|
| 1-ORANGE | 5-BLACK |
| 2-WHITE | 6-CATERPILLAR YELLOW |
| 3-SPECTRUM GRAY | 7-CATO GOLD |
| 4-SUNBELT GREEN | 8-RED |

THE SERIAL NUMBER MAY BE REQUIRED.

DCA-125SSK — ENCLOSURE ASSY.

ENCLOSURE ASSY. FROM S/N3656387

<u>NO.</u>	<u>PART NO.</u>	<u>PART NAME</u>	<u>QTY.</u>	<u>REMARKS</u>
1	8135111212	BASE	1	
	7305116204	FLOOR PANEL	1	
3	0017108002	HEX. HEAD BOLT	10	
4	8135116004	COVER	1	
5	0017108020	HEX. HEAD BOLT	2	
6	8135121212	FRONT FRAME	1 FROM S/N3656387 TO 3662598
7	0017110025	HEX. HEAD BOLT	4	
8	0845039703	FILLER BRACKET	1	
9	0017108020	HEX. HEAD BOLT	4	
10	8135125104	COVER, FRONT FRAME	1	
	8135102204	LINING	1	
11	0017108020	HEX. HEAD BOLT	16	
12	7305125003	COVER, FRONT FRAME	1	
13	0017108020	HEX. HEAD BOLT	10	
14	8135131212	CENTER FRAME	1	
5	0010014045	HEX. HEAD BOLT	12	
	0030014000	HEX. NUT	12	
	0040014000	LOCK WASHER	12	
	0041614000	PLAIN WASHER	12	
16	8135141312	REAR FRAME	1	
17	0017110025	HEX. HEAD BOLT	2	
18	0017108020	HEX. HEAD BOLT	2	
19	8135155213	COVER, REAR FRAME	1	
	8135102304	LINING	1	
20	0017108020	HEX. HEAD BOLT	12	
21	8135143413	DOOR, REAR FRAME	1	
	0225100630	RUBBER SEAL	1	
22	8135143513	DOOR, REAR FRAME	1	
23	8135147004	WINDOW PLATE	1	
	0037906000	HEX. NUT	6	
	0207006000	HEX. NUT	6	
36	0845047104	HINGE	2	
37	0845047204	HINGE	2	
38	0017108020	HEX. HEAD BOLT	8	
39	8135161012	ROOF PANEL	1	
40	0845052203	COVER	1	
42	8135161103	ROOF PANEL	1	
43	0017108020	HEX. HEAD BOLT	36	
44	8135181312	SPLASHER PANEL	1	
45	0010008065	HEX. HEAD BOLT	4	
	0040008000	LOCK WASHER	4	
	0041608000	PLAIN WASHER	4	
46	8135171713	SIDE DOOR	1	
	8135102523	LINING	1	

DCA-125SSK — ENCLOSURE ASSY.

ENCLOSURE ASSY. FROM S/N3656387

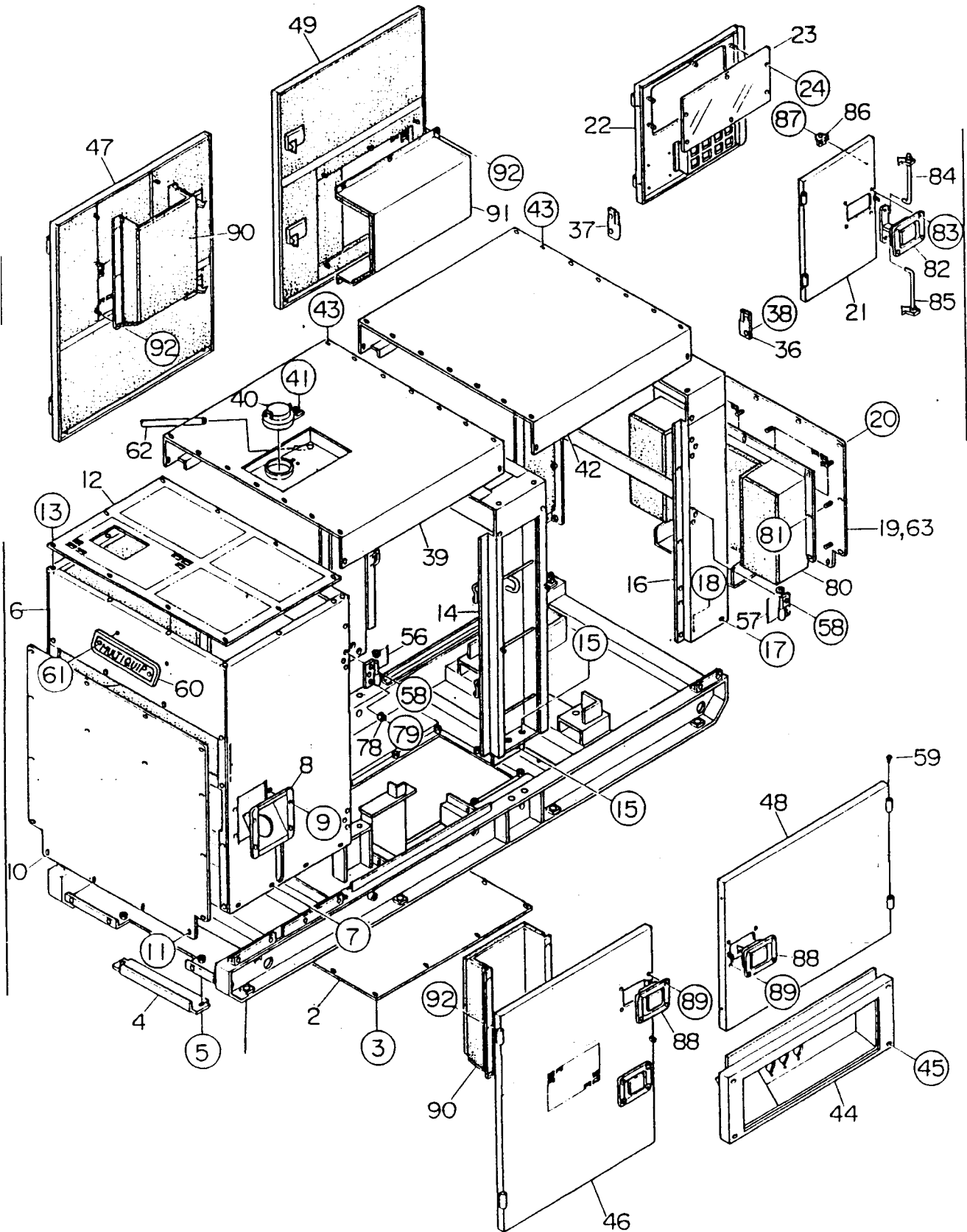

DCA-125SSK — ENCLOSURE ASSY.

ENCLOSURE ASSY. FROM S/N3656387

<u>NO.</u>	<u>PART NO.</u>	<u>PART NAME</u>	<u>QTY.</u>	<u>REMARKS</u>
47	8135171613	SIDE DOOR	1	
	8135102423	LINING	1	
48	8135171513	SIDE DOOR	1	
	8135102714	LINING	1	
49	8135171813	SIDE DOOR	1	
	8135102613	LINING	1	
56	0845046904	HINGE	4	
57	0845047004	HINGE	4	
58	0017108020	HEX. HEAD BOLT	16	
59	0845031504	CAP	12	
60	0600500090	EMBLEM	2 FROM S/N3660500
61	0021106020	MACHINE SCREW	4	
63	0840625902	STICKER	1	
78	0601850097	RUBBER CUSHION	10	
79	0221008025	MACHINE SCREW	8	
80	C0444300403	DUCT	1	

ADD THE FOLLOWING DIGITS AFTER THE PART NUMBER
WHEN ORDERING ANY PAINTED PANEL TO INDICATE
COLOR OF UNIT:

1-ORANGE	5 -BLACK
2-WHITE	6 -CATERPILLAR YELLOW
3 -SPECTRUM GRAY	7 -CATO GOLD
4 -SUNBELT GREEN	8 -RED

THE SERIAL NUMBER MAY BE REQUIRED.

DCA-125SSK — RUBBER SEALS ASSY.

RUBBER SEALS ASSY.

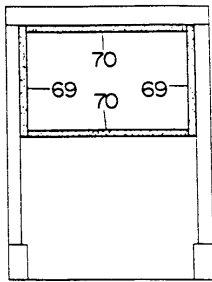
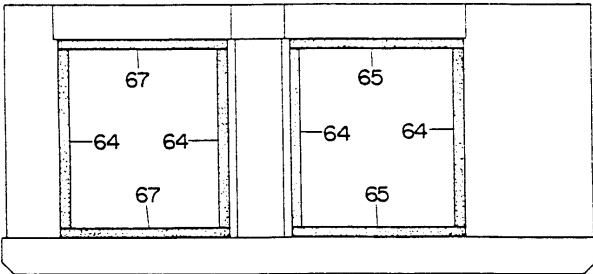
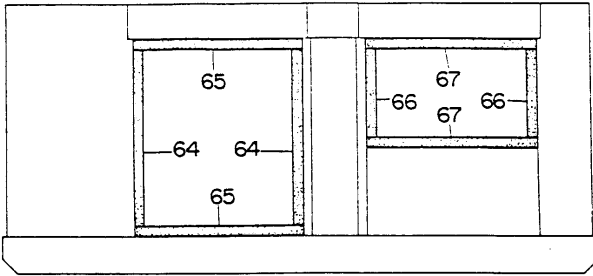
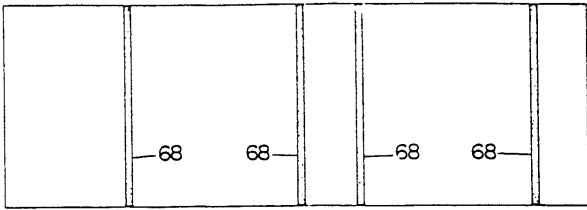

UP TO S/N3656386

FROM S/N3656387

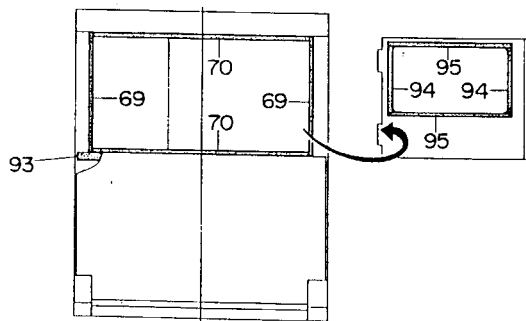
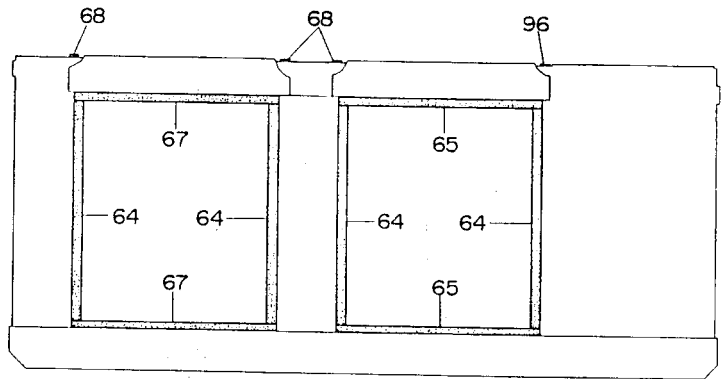
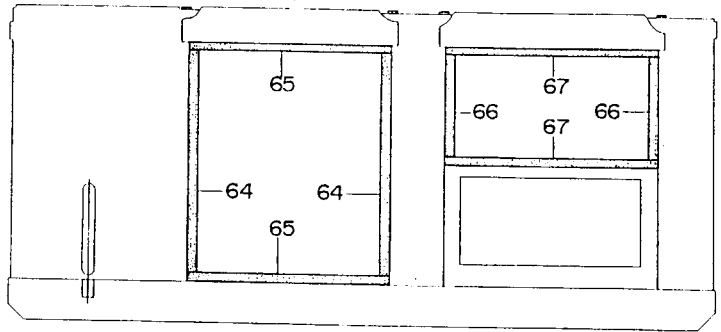

DCA-125SSK — RUBBER SEALS ASSY.

RUBBER SEALS ASSY.

<u>NO.</u>	<u>PART NO.</u>	<u>PART NAME</u>	<u>QTY.</u>	<u>REMARKS</u>
64	0223301060	RUBBER SEAL	6	UP TO S/N3656386
64	0228901080	RUBBER SEAL	6	FROM S/N3656387
65	0223300890	RUBBER SEAL	4	UP TO S/N3656386
65	0228901080	RUBBER SEAL	4	FROM S/N3656387
66	0223300710	RUBBER SEAL	2	UP TO S/N3656386
66	0228900730	RUBBER SEAL	2	FROM S/N3656387
67	0223300860	RUBBER SEAL	4	UP TO S/N3656386
67	0228900860	RUBBER SEAL	2	FROM S/N3656387
68	0225101100	RUBBER SEAL	4	UP TO S/N3656386
68	0229201100	RUBBER SEAL	4	FROM S/N3656387 TO 3662598
69	0221200600	RUBBER SEAL	2	UP TO S/N3656386
69	0221200640	RUBBER SEAL	2	FROM S/N3656387
70	0221200930	RUBBER SEAL	2	UP TO S/N3656386
70	0228800970	RUBBER SEAL	2	FROM S/N3656387

DCA-125SSK — NAME PLATE AND DECALS

NAME PLATE ASSY.

<u>NO.</u>	<u>PART NO.</u>	<u>PART NAME</u>	<u>QTY.</u>	<u>REMARKS</u>
1	0840624904	DECAL;OPERATING PROCEDURE;S3035	2	
CONTROL BOX GROUP				
	0840624504	DECAL; CIRCUIT BRAKER; S3031	1	
	0840624414	DECAL; SELECTOR SWITCH;S3030A	1	
	3330670704	DECAL; CAUTION;S2518	1	
	0800520904	PLATE, AMMETER CHG-OVR SW.;N2438	1	
	0800520814	PLATE, VOLTMETER CHG-OVR. SW.;N2439	1	
	0840624704	DECAL; PILOT LAMP;S3033	1	
	0840624804	DECAL; VOLTAGE REGULATOR;S3034	1	
	0840624604	DECAL; PANEL LIGHT SWITCH;S3032	1	
	0800520100	DECAL;ON-OFF; AT202	1	
	8130670002	DECAL;S3070	1	
	0840627204	DECAL;CAUTION-CHG. OVR.SW.;S3246	1 FROM S/N3402611
ENGINE OPERATING PANEL GROUP				
	0840625204	DECAL;SPEED CONTROL HANDLE;S3038	1	
	0840625404	DECAL;HANDLE POSITION; S3040	1	
	0840625104	DECAL;STARTER SWITCH;S3037	1	
	0840625004	DECAL; PREHEAT LAMP;S3036	1	
	0840625314	DECAL; AIR CLEANER INDICATOR;S3039A	1	
OUTPUT TERMINAL GROUP				
	8110670303	DECAL; RECEPT. AND CIRC. BREAK.;S3046 ..	1 UP TO S/N3402610
	8110670313	DECAL; RECEPT. AND CIRC. BREAK.;S3046A	1 FROM S/N3402611
	0840619504	DECAL; GROUND MARK;S2726	1	
	0840619904	DECAL; CAUTION;S2731	1	
	0840627103	DECAL;CABLE JOINING;S3245	1 FROM S/N3402611
BATTERY GROUP				
	0800689404	DECAL;+;S2090	2	
	0800689504	DECAL;-;S2091	2	
ENCLOSURE GROUP				
	1320620904	DECAL;DIESEL FUEL;S1756	1	
	1320610603	DECAL;WATER/OIL;S1760	1	
	6360610304	DECAL;WATER;S1880	1	
	6360620004	DECAL;FUEL DRAIN PLUG;S1883	1	
	6360620204	DECAL;OIL DRAIN PLUG;S1885	1	
	6360610604	DECAL; WARNING;S1948	1 UP TO S/N3402610
	0840627304	DECAL; WARNING;S3247	1 FROM S/N3402611
	1320621504	DECAL; SUPPORT HOOK;S2257	2	
	8130670504	DECAL; CAUTION;S3130	1	
	8130630403	STRIPE	1 UP TO S/N3656386

DCA-125SSK — NAME PLATE AND DECALS

NAME PLATE ASSY.

<u>NO.</u>	<u>PART NO.</u>	<u>PART NAME</u>	<u>QTY.</u>	<u>REMARKS</u>
	C0561101103	STRIPE	1	FROM S/N3656387
	8130630503	STRIPE;LEFT SIDE	1	UP TO S/N3656386
	C0561101203	STRIPE	1	FROM S/N3656387
	8130630303	STRIPE;RIGHT SIDE	1	UP TO S/N3656386
	C0561101003	STRIPE	1	FROM S/N3656387
	8140630204	STRIPE	2	UP TO S/N3656386
	C0561100903	STRIPE	2	FROM S/N3656387
	8130630603	STRIPE; LEFT SIDE	1	UP TO S/N3656386
	C0561101303	STRIPE	1	FROM S/N3656387
	8130630104	STRIPE; RIGHT SIDE	1	UP TO S/N3656386
	C0561100803	STRIPE	1	FROM S/N3656387
	8130630004	STRIPE	2	UP TO S/N3656386
	C0561100704	STRIPE	2	FROM S/N3656387

PAYMENT TERMS

Terms of payment for parts are net 10 days.

FREIGHT POLICY

All parts orders will be shipped collect or prepaid with the charges added to the invoice. All shipments are F.O.B. point of origin. Multiquip's responsibility ceases when a signed manifest has been obtained from the carrier, and any claim for shortage or damage must be settled between the consignee and the carrier.

MINIMUM ORDER

The minimum charge for orders from Multiquip is \$15.00 net. Customers will be asked for instructions regarding handling of orders not meeting this requirement.

RETURNED GOODS POLICY

Return shipments will be accepted and credit will be allowed, subject to the following provisions:

1. A Returned Material Authorization must be approved by Multiquip prior to shipment.
2. To obtain a Return Material Authorization, a list must be provided to Multiquip Parts Sales that defines item numbers, quantities, and descriptions of the items to be returned.
 - a. The parts numbers and descriptions must match the current parts price list.
 - b. The list must be typed or computer generated.
 - c. The list must state the reason(s) for the return.
 - d. The list must reference the sales order(s) or invoice(s) under which the items were originally purchased.
 - e. The list must include the name and phone number of the person requesting the RMA.
3. A copy of the Return Material Authorization must accompany the return shipment.

4. Freight is at the sender's expense. All parts must be returned freight prepaid to Multiquip's designated receiving point.
5. Parts must be in new and resalable condition, in the original Multiquip package (if any), and with Multiquip part numbers clearly marked.
6. The following items are not returnable:
 - a. Obsolete parts. (If an item is listed in the parts price book as being replaced by another item, it is obsolete.)
 - b. Any parts with a limited shelf life (such as gaskets, seals, "O" rings, and other rubber parts) that were purchased more than six months prior to the return date.
 - c. Any line item with an extended dealer net price of less than \$5.00.
 - d. Special order items.
 - e. Electrical components.
 - f. Paint, chemicals, and lubricants.
 - g. Decals and paper products.
 - h. Items purchased in kits.
7. The sender will be notified of any material received that is not acceptable.
8. Such material will be held for 5 working days from notification, pending instructions. If a reply is not received within 5 days, the material will be returned to the sender at his expense.
9. Credit on returned parts will be issued at dealer net price at time of the original purchase, less a 15% restocking charge.
10. In cases where an item is accepted for which the original purchase document can not be determined, the price will be based on the list price that was effective twelve months prior to the RMA date.
11. Credit issued will be applied to future purchases only.

PRICING AND REBATES

Prices are subject to change without prior notice. Price changes are effective on a specific date and all orders received on or after that date will be billed at the revised price. Rebates for price declines and added charges for price increases will not be made for stock on hand at the time of any price change.

Multiquip reserves the right to quote and sell direct to Government agencies, and to Original Equipment Manufacturer accounts who use our products as integral parts of their own products.

SPECIAL EXPEDITING SERVICE

A \$20.00 to \$50.00 surcharge will be added to the invoice for special handling including bus shipments, insured parcel post or in cases where Multiquip must personally deliver the parts to the carrier.

LIMITATIONS OF SELLER'S LIABILITY

Multiquip shall not be liable here under for damages in excess of the purchase price of the item with respect to which damages are claimed, and in no event shall Multiquip be liable for loss of profit or good will or for any other special, consequential or incidental damages.

LIMITATION OF WARRANTIES

No warranties, express or implied, are made in connection with the sale of parts or trade accessories nor as to any engine not manufactured by Multiquip. Such warranties made in connection with the sale of new, complete units are made exclusively by a statement of warranty packaged with such units, and Multiquip neither assumes nor authorizes any person to assume for it any other obligation or liability whatever in connection with the sale of its products. A part from such written statement of warranty, there are no warranties, express, implied or statutory, which extend beyond the description of the products on the face hereof.

PARTS AND OPERATION MANUAL

HERE'S HOW TO GET HELP

*PLEASE HAVE THE MODEL AND SERIAL NUMBER
ON-HAND WHEN CALLING*

PARTS DEPARTMENT

800/427-1244 or 310/537-3700

FAX: 800/672-7877 or 310/637-3284

SERVICE DEPARTMENT

800/835-2551 or 310/537-3700

FAX: 310/638-8046

WARRANTY DEPARTMENT

800/835-2551 or 310/537-3700

FAX: 310/638-8046

MAIN

800/421-1244 or 310/537-3700

FAX: 310 - 537-3927

Manufactured for Multiquip Inc.
by
DENYO, MANUFACTURING, CO., USA



MULTIQUIP INC.

POST OFFICE BOX 6254

CARSON, CA 90749

310-537-3700 • 800-421-1244

FAX: 310-537-3927

E-MAIL: mq@multiquip.com

WWW: multiquip.com

Atlanta • Boise • Dallas • Houston • Newark
Quebec, Canada • Manchester, UK • Rio De Janeiro, BR • Guadalajara, MX