

# PARTS AND OPERATION MANUAL

## MQ POWER DCA-400SSK WHISPERWATT™ GENERATOR

FOR

SUNBELT

S/N3703369 to 3703380  
S/N3703869 to 3703878

(For other Serial Numbers,  
refer to standard or GEER manuals)

**PART LIST NO. C3875300204B**

Revision #0 (06/01/01)



**MULTIQUIP INC.**  
18910 WILMINGTON AVE.  
CARSON, CALIFORNIA 90746  
310-537-3700  
800-421-1244  
FAX: 310-537-3927  
E-mail: [mq@multiquip.com](mailto:mq@multiquip.com) • [www.multiquip.com](http://www.multiquip.com)

**PARTS DEPARTMENT:**  
800-427-1244  
FAX: 800-672-7877

**SERVICE DEPARTMENT:**  
800-835-2551  
FAX: 310-638-8046



# **WARNING**



## **CALIFORNIA — Proposition 65 Warning**

**Diesel engine exhaust and some of its constituents are known to the State of California to cause cancer, birth defects and other reproductive harm.**

## **HERE'S HOW TO GET HELP**

*PLEASE HAVE THE MODEL AND SERIAL NUMBER  
ON-HAND WHEN CALLING*

### ***PARTS DEPARTMENT***

*800/427-1244 or 310/537-3700*

*FAX: 800/672-7877 or 310/637-3284*

### ***SERVICE DEPARTMENT***

*800/835-2551 or 310/537-3700*

*FAX: 310/638-8046*

### ***WARRANTY DEPARTMENT***

*800/835-2551 or 310/537-3700*

*FAX: 310/638-8046*

### ***MAIN***

*800/421-1244 or 310/537-3700*

*FAX: 310 - 537-3927*

# TABLE OF CONTENTS

Here's How To Get Help ..... 3  
Table Of Contents ..... 4  
Parts Ordering Procedures ..... 5  
Rules For Safe Operation ..... 6-9  
Towing ..... 10  
Trailer Safety Guidelines ..... 11-17  
Trailer Wiring Diagram ..... 18  
Electric Brake Troubleshooting ..... 19  
Hydraulic Brake Troubleshooting ..... 20  
Operation And Safety Decals ..... 21-24  
Specifications ..... 25  
General Information ..... 26-27  
Major Components ..... 28  
Dimensions ..... 30-31  
Control Panel ..... 32-33  
Engine Operating Panel ..... 34-35  
Output Terminal Overview ..... 36-41  
Installation ..... 42-43  
Pre-Setup ..... 44-47  
Load Application ..... 48  
Generator Start-Up Procedure (Manual) ..... 49-53  
Generator Start-Up Procedure (Auto) ..... 54  
Generator Shut-Down Procedure ..... 55  
Maintenance ..... 56-57  
Generator Wiring Diagram ..... 58  
Engine Wiring Diagram ..... 59  
Troubleshooting (Engine) ..... 60-62  
Troubleshooting (MPEC) ..... 63  
Explanation Of Codes In Remarks Column ..... 64  
Suggested Spare Parts ..... 65

## MQ Power DCA-400SSK AC Generator

Generator Assembly ..... 66-69  
Control Box Assembly ..... 70-75  
Engine Radiator Assembly ..... 76-79  
Engine Operating Panel Assembly ..... 80-81  
Governor Actuator Assembly ..... 82-83  
Output Terminal Assembly ..... 84-85  
Battery Assembly ..... 86-87  
Muffler Assembly ..... 88-89  
Fuel Piping Assembly ..... 90-91  
Blow-by Oil Mist Pump Assembly ..... 92-93  
Jacket Water Heater Assembly ..... 94-95  
Enclosure (Part 1) Assembly ..... 96-99  
Enclosure (Part 2) Assembly ..... 100-103  
Enclosure (Part 3) Assembly ..... 104-107  
Enclosure (Rubber Seals) ..... 108-109  
Name Plate and Decals ..... 110-113

Terms and Conditions Of Sale — Parts ..... 114

**NOTE**

*Specification and part number are subject to change without notice.*

- Dealer account number
- Dealer name and address
- Shipping address (if different than billing address)
- Return fax number
- Applicable model number
- Quantity, part number and description of each part
- Specify preferred method of shipment:
  - UPS Ground
  - UPS Second Day or Third Day\*
  - UPS Next Day\*
  - Federal Express Priority One (please provide us with your Federal Express account number)\*
  - Airborne Express\*
  - Truck or parcel post

*\*Normally shipped the same day the order is received, if prior to 2PM west coast time.*

## Earn Extra Discounts when you order by FAX!

All parts orders which include complete part numbers and are received by fax qualify for the following extra discounts:

<u>Number of line items ordered</u>	<u>Additional Discount</u>
1-9 items	3%
10+ items**	5%

**Get special freight allowances when you order 10 or more line items via FAX! \*\***

- UPS Ground Service at no charge for freight
- PS Third Day Service at one-half of actual freight cost

No other allowances on freight shipped by any other carrier.

\*\*Common nuts, bolts and washers (all items under \$1.00 list price) do not count towards the 10+ line items.

\*DISCOUNTS ARE SUBJECT TO CHANGE\*

Fax order discount and UPS special programs revised June 1, 1995

**Extra Fax Discount  
for Domestic USA  
Dealers Only**

**Up to 5%  
extra savings!**

**UPS  
Special**  
*For faxed orders only*

**Now! Direct TOLL-FREE access  
to our Parts Department!**

Toll-free nationwide:

**800-421-1244**

Toll-free FAX:

**800/6-PARTS-7 • 800-672-7877**

# RULES FOR SAFE OPERATION

## CAUTION:



Failure to follow instructions in this manual may lead to serious injury or even death! This equipment is to be operated by trained and qualified personnel only! This equipment is for industrial use only.

The following safety guidelines should always be used when operating the DCA-400SSK portable generator:

### GENERAL SAFETY

- **DONOT** operate or service this equipment before reading this entire manual.



- This equipment should not be operated by persons under 18 years of age.

- **NEVER** operate this equipment without proper protective clothing, shatterproof glasses, steel-toed boots and other protective devices required by the job.



- **NEVER** operate this equipment when not feeling well due to fatigue, illness or taking medicine.



- **NEVER** operate this equipment under the influence of drugs or alcohol.



- **NEVER** use accessories or attachments, which are not recommended by MQ Power for this equipment. Damage to the equipment and/or injury to user may result.

- Manufacturer does not assume responsibility for any accident due to equipment modifications.

- Whenever necessary, replace nameplate, operation and safety decals when they become difficult read.

- Always check the machine for loosened threads or bolts before starting.

- **NEVER** touch the hot exhaust manifold, muffler or cylinder. Allow these parts to cool before servicing engine or generator.



- **High Temperatures** – Allow the engine to cool before adding fuel or performing service and maintenance functions. Contact with *hot* components can cause serious burns.

- The engine of this generator requires an adequate free flow of cooling air. Never operate the generator in any enclosed or narrow area where free flow of the air is restricted. If the air flow is restricted it will cause serious damage to the generator or engine and may cause injury to people. The generator engine gives off **DEADLY** carbon monoxide gas.

## CAUTION:



Always refuel in a well-ventilated area, away from sparks and open flames.

- Always use extreme caution when working with **flammable** liquids. When refueling, **stop the engine** and allow it to cool.

**DO NOT** smoke around or near the machine. Fire or explosion could result from fuel vapors, or if fuel is spilled on a hot engine.

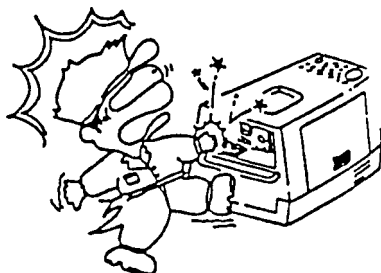


- **NEVER** operate the generator in an explosive atmosphere or near combustible materials. An explosion or fire could result causing severe *bodily harm or even death*.

- Topping-off to filler port is dangerous, as it tends to spill fuel.

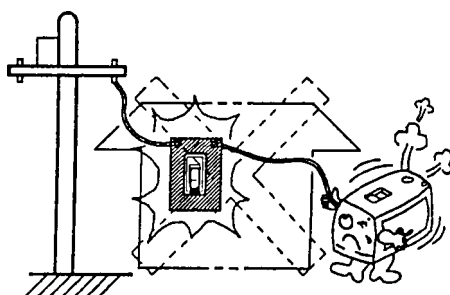
## RULES FOR SAFE OPERATION

### CAUTION:



- **NEVER** touch output terminals during operation. This is extremely dangerous. Always stop the machine when contact with the output terminals.

### CAUTION:



- **Backfeed to a utility system can cause electrocution and/or property damage. Do not connect to any building's electrical system except through an approved device or after building main switch is opened.**

### CAUTION:



**Never** use damaged or worn cables when connecting power tools or equipment to the generator. Make sure power connecting cables are securely connected to the generator's output terminals, insufficient tightening of the terminal connections may cause damage to the generator and electrical shock.

### CAUTION:



**DO NOT** touch or open any of the below mentioned components while the generator is running. Always allow sufficient time for the engine and generator to cool before performing maintenance.

#### Radiator

1. **Radiator Cap** - Removing the radiator cap while the engine is hot will result in high pressurized, boiling water to gush out of the radiator, therefore causing severe scalding to any persons in the general area of the generator.
2. **Coolant Drain Plug** - Removing the coolant drain plug while the engine is hot will result in hot coolant to gush out of the coolant drain plug, therefore causing severe scalding to any persons in the general area of the generator.
3. **Engine Oil Drain Plug** - Removing the engine oil drain plug while the engine is hot will result in hot oil to gush out of the oil drain plug, therefore causing severe scalding to any persons in the general area of the generator.

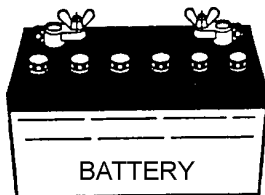
## Battery

### CAUTION:



Never over fill the battery with water above the upper limit.

The battery contains acids that can cause injury to the eyes and skin. To avoid eye irritation, always wear safety glasses. Use well insulated gloves when picking up the battery. Use the following guidelines when handling the battery:



1. **DO NOT** drop the battery. There is the possibility of risk that the battery may explode.
2. **DO NOT** expose the battery to open flames, sparks, cigarettes etc. The battery contains combustible gases and liquids. If these gases and liquids come in contact with a flame or spark, an explosion could occur.
3. Always keep the battery charged. If the battery is not charged a buildup of combustible gas will occur.
4. Always keep battery charging and booster cables in good working condition. Repair or replace all worn cables.
5. Always recharge the battery in an open air environment, to avoid risk of a dangerous concentration of combustible gases.
6. In case the battery liquid (dilute sulfuric acid) comes in contact with **clothing or skin**, rinse skin or clothing immediately with plenty of water.
7. In case the battery liquid (dilute sulfuric acid) comes in contact with your **eyes**, rinse eyes immediately with plenty of water, then contact the nearest doctor or hospital, and seek medical attention.

- **NEVER** run the engine without an air filter. Severe engine damage may occur.
- Always service air cleaner frequently to prevent carburetor malfunction.
- Always disconnect the battery before performing service on the generator.
- Always be sure the operator is familiar with proper safety precautions and operations techniques before using generator.
- Always store equipment properly when it is not being used. Equipment should be stored in a clean, dry location out of the reach of children.
- **DO NOT** leave the generator running in the manual mode unattended.
- **DO NOT** allow unauthorized people to operate this equipment.
- Always read, understand, and follow procedures in Operator's Manual before attempting to operate equipment.
- Always be sure the operator is familiar with proper safety precautions and operations techniques before using generator.
- Refer to the *Komatsu Engine Owner's Manual* for engine technical questions or information.

### Loading and Unloading (Crane)

- Before lifting, make sure the generator's lifting hook is secure and that there is no apparent damage to the generator itself (loose screws, nuts and bolts). If any part is loose or damaged, please take corrective action before lifting.
- Always drain fuel prior to lifting.
- Always make sure crane or lifting device has been properly secured to the hook of guard frame on generator.
- **NEVER** lift the machine while the engine is running.
- Use adequate lifting cable (wire or rope) of sufficient strength.
- When lifting the generator, always use the balanced center-point suspension hook and lift straight upwards.
- **NEVER** allow any person or animal to stand underneath the machine while lifting.
- When loading the generator on a truck, be sure to use the front and back frame bars as a means to secure the generator during transport.

## Transporting

- Always shutdown engine before transporting.
- Tighten fuel tank cap securely.
- Drain fuel when transporting generator over long distances or bad roads.
- Always tie-down the generator during transportation by securing the generator.
- If generator is mounted on a trailer, make sure trailer complies with all local and state safety transportation laws. See page 10 for basic towing procedures.

## Emergencies

- Always know the location of the nearest **fire extinguisher** and **first aid kit**. Know the location of the nearest telephone. Also know the phone numbers of the nearest **ambulance**, **doctor** and **fire department**.

## Maintenance Safety

- **NEVER** lubricate components or attempt service on a running machine.
- Always allow the machine a proper amount of time to cool before servicing.
- Keep the machinery in proper running condition.
- Fix damage to the machine immediately and always replace broken parts.
- Dispose of hazardous waste properly. Examples of potentially hazardous waste are used motor oil, fuel, and fuel filters.
- **DO NOT** use plastic containers to dispose of hazardous waste.
- **DO NOT** pour waste, oil or fuel directly onto the ground, down a drain or into any water source.

## Towing Safety Precautions

### CAUTION:



Check with your county or state safety towing regulations department before towing your generator.

To reduce the possibility of an accident while transporting the generator on public roads, always make sure the trailer (Figure 1) that supports the generator and the towing vehicle are in good operating condition and both units are mechanically sound.

The following list of suggestions should be used when towing your generator:

- Make sure that the hitch and coupling of the towing vehicle are rated equal to, or greater than the trailer "gross vehicle weight rating" (GVWR).
- **ALWAYS** inspect the hitch and coupling for wear. **NEVER** tow a trailer with defective hitches, couplings, chains etc.
- Check the tire air pressure on both the towing vehicle and the trailer. Also check the tire tread wear on both vehicles.
- **ALWAYS** make sure the trailer is equipped with a "Safety Chain".
- **ALWAYS** attach trailer's safety chain to bumper of towing vehicle.
- **ALWAYS** make sure the vehicle and trailer directional, backup, brake, and trailer lights are connected and working properly.
- The maximum speed unless otherwise posted for highway towing is **45 MPH**. Recommended off-road towing is not to exceed **10 MPH** or less depending on type of terrain.
- Place *chocked blocks* underneath wheel to prevent *rolling*, while parked.
- Place *support blocks* underneath the trailer's bumper to prevent *tipping*, while parked.
- Use the trailer's hand winch to adjust the height of the trailer, then insert locking pin to lock wheel stand in place, while parked.
- Avoid sudden stops and starts. This can cause skidding, or jackknifing. Smooth, gradual starts and stops will improve gas mileage.
- Avoid sharp turns to prevent rolling.
- Remove wheel stand when transporting.
- **DO NOT** transport generator with fuel in tank.

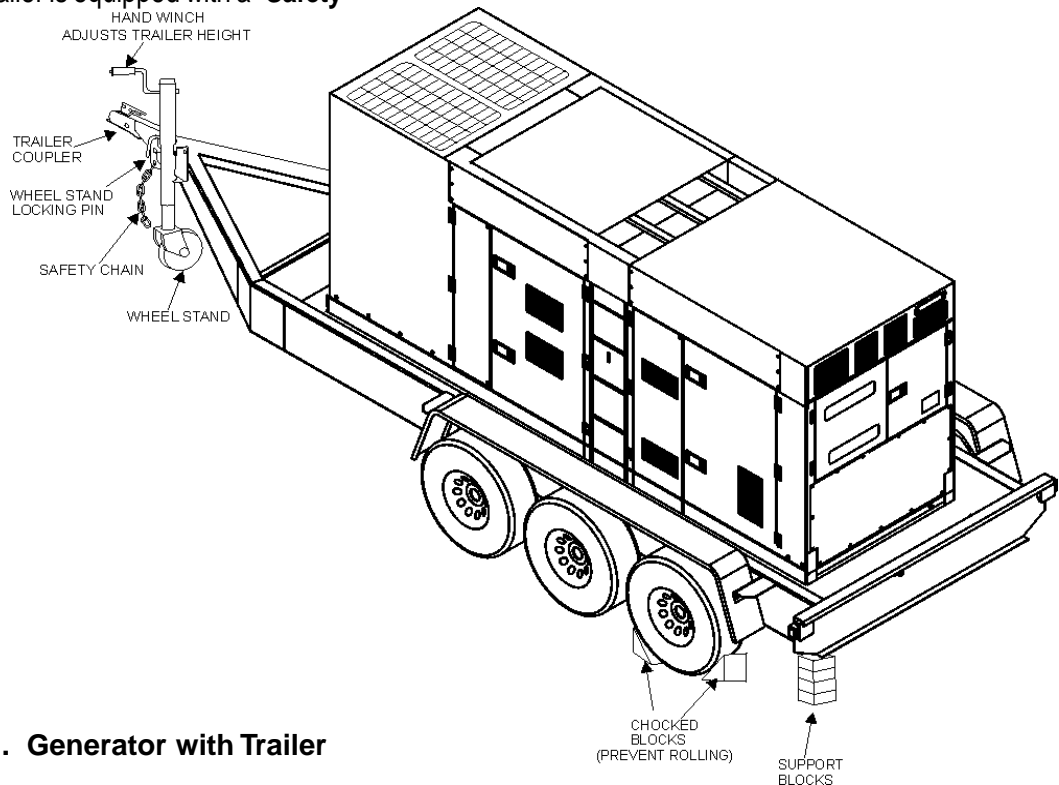


Figure 1. Generator with Trailer

## CAUTION:



**ALWAYS** make sure the trailer is in good operating condition. Check the tires for proper inflation and wear. Also check the wheel lug nuts for proper tightness.

### Explanation of Chart:

This section is intended to provide the user with trailer service and maintenance information. The service and maintenance guidelines referenced in this section apply a wide range of trailers. Periodic inspection of the trailer will ensure safe towing of the equipment and will prevent damage to the equipment and personal injury.

It is the purpose of this section to cover the major maintenance components of the trailer. The following trailer components will be discussed in this section:

- Brakes
- Tires
- Lug Nut Torquing
- Suspension
- Electrical
- Brake Troubleshooting Tables

Use the following definitions with reading Table 1.

1. **Fuel Cell** - Provides an adequate amount of fuel for the equipment in use. Fuel cells must be empty when transporting equipment.
2. **Braking System** - System employed in stopping the trailer. Typical braking systems are electric, surge, hydraulic, hydraulic-surge and air.
3. **GVWR**- Gross Vehicle Weight Rating (GVWR), is the maximum number of pounds the trailer can carry, including the fuel cell (empty).
4. **Frame Length** - This measurement is from the ball hitch to the rear bumper (reflector).
5. **Frame Width** - This measurement is from fender to fender.
6. **Jack Stand** - Trailer support device with maximum pound requirement from the tongue of the trailer.
7. **Coupler** - Type of hitch used on the trailer for towing.
8. **Tire Size** - Indicates the diameter of the tire in inches (10,12,14, etc.), and the width in millimeters (175,185,205, etc.). The tire diameter must match the diameter of the tire rim.
9. **Tire Ply** - The tire ply (layers) number is rated in letters; 2-ply,4-ply,6-ply, etc.
10. **Wheel Hub** - The wheel hub is connected to the trailer's axle.
11. **Tire Rim** - Tires are mounted on a tire rim. The tire rim must match the size of the tire.
12. **Lug Nuts** - Used to secure the wheel to the wheel hub. Always use a torque wrench to tighten down the lug nuts. See Table 4 and Figure 5 or lug nut tightening and sequence.
13. **Axle** - Indicates the maximum weight the axle can support in pounds, and the diameter of the axle expressed in inches (see Table 3). Please not that some trailers have a double axle. This will be shown as 2-6000 lbs., meaning two axles with a total weight capacity of 6000 pounds.
14. **Suspension** - Protects the trailer chassis from shocks transmitted through the wheels. Types of suspension used are leaf, Q-flex, and air ride.
15. **Electrical** - Electrical connectors (looms) are provided with the trailer so the brake lights and turn signals can be connected to the towing vehicle. See Figure 19 for proper wiring connections.
16. **Application** - Indicates which units can be employed on a particular trailer.

# TRAILER-SPECIFICATIONS

**Table 1. Specifications**

MODEL	APPLICATION	FUEL CELL	BRAKE SYSTEM	GVWR	FRAME LENGTH	FRAME WIDTH	JACK STAND
TRLR-10-15	TLG-12, DCA15, TLW-300	NO	NO	1900LBS	96"	50"	800LB. FULL TILT WHEEL
TRLR-10X	TLG-12, DCA15, TLW-300	NO	NO	1900LBS	96"	50"	800LB. FULL TILT WHEEL
TRLR-10XF	TLG-12, DCA15, TLW-300	51 GAL	NO	1900LBS	96"	50"	800LB. FULL TILT WHEEL
TRLR-225W	DCA-10	NO	NO	2200LBS	85"	42"	800LB. FULL TILT WHEEL
BLW-400	BLW-400	NO	ELECTRIC	2700LBS	W/MAST 154" W/O 124"	55" (78" TALL)	800LB. FULL TILT WHEEL
TRLR-15XF	DCA-15	41 GAL	NO	2700LBS	124"	55"	800LB. FULL TILT WHEEL
TRLR-50X	DCA-25	NO	NO	2700LBS	124"	55"	800LB. FULL TILT WHEEL
TRLR-50XF	DCA-25	41 GAL	NO	2700LBS	124"	55"	800LB. FULL TILT WHEEL
TRLR-25SBT	DCA-25	NO	NO	2990LBS	120"	66"	800LB. FULL TILT WHEEL
TRLR-70W	DCA-45, -60, 70	NO	SURGE	7000LBS	186"	77"	2000LB. FLAT PAD
TRLR-70X	DCA-45, -60, 70	OPT	SURGE	7000LBS	138"	66"	2000LB. FLAT PAD
TRLR-70XF	DCA-45, -60, 70	53 GAL	SURGE	7000LBS	138"	66"	2000LB. FLAT PAD
TRLR-100XF	DCA-100, 125	150 GAL	HYDRAULIC SURGE	7000LBS	190"	76"	2000LB. FLAT PAD
TRLR-85/125	DCA-85, 100, 125	145 GAL	HYDRAULIC	10000LBS	186"	77"	2000LB. FLAT PAD
TRLR-150XF	DCA-150, 180	200 GAL	HYDRAULIC SURGE	11160LBS	204"	84"	5000 LB. FLAT PAD
TRLR-220XF	DCA-220	250 GAL	HYDRAULIC SURGE	14000LBS	222"	83"	5000 LB. FLAT PAD
TRLR-300XF	DCA-300	250 GAL	HYDRAULIC SURGE	18000LBS	238"	83"	5000 LB. FLAT PAD
TRLR-400XF	DCA-400	350 GAL	ELECTRIC	18000LBS	238"	83"	5000 LB. FLAT PAD
TRLR-600XF	DCA-600, 800	550 GAL	AIR	30000LBS	384"	96"	5000 LB. FLAT PAD
TRLR-800SX	DCA-600, 800	550 GAL	AIR	30000LBS	384"	96"	5000 LB. FLAT PAD

# TRAILER-SPECIFICATIONS

**Table 1. Specifications (Con't)**

MODEL	COUPLER	TIRES	WHEELS	AXLE	HUBS	SUSPENSION	ELECTRICAL
TRLR-10-15W	2" BALL CLASS 2 ADJUSTABLE	175-13C	13"X4.50"	2200# 2X2	5 LUG	3 LEAF	4 WIRE LOOM W/ 4 POLE FLAT
TRLR-10X	2" BALL CLASS 2 ADJUSTABLE	175-13C	13"X4.5"	2200#2X2	5 LUG	3 LEAF	4 POLE FLAT
TRLR-10XF	2" BALL CLASS 2 ADJUSTABLE	175-13C	13"X4.5"	2200#2X2	5 LUG	3 LEAF	4 POLE FLAT
TRLR-225W	2" BALL CLASS 2 ADJUSTABLE	175-13B	13X4.5"	2200#2X2	5 LUG	Q FLEX	4 POLE FLAT
BLW 400	2" BALL CLASS 2 ADJUSTABLE	175-13C	13 X 4.5"	2200#2X2	5 LUG	3 LEAF	4 POLE FLAT
TRLR-15XF	2" BALL CLASS	B78-13LRC	13"X4.50"	3500# 2-1/2"	5 LUG	4 LEAF	4 POLE RUBBER FLAT
TRLR-50X	2" BALL CLASS	B78-13LRC	13"X4.50"	3500lbs. 2-3/8"	5 LUG	4 LEAF	4 POLE RUBBER FLAT
TRLR-50XF	2" BALL CLASS	B78-13LRC	13"X4.50"	3500lbs. 2-3/8"	5 LUG	4 LEAF	4 POLE RUBBER FLAT
TRLR-70W	2" BALL CLASS 3" ADJUSTABLE	205-14C BIAS (4)	14"X5"	3500lbs. 3"	5 LUG	5 LEAF	4 POLE RUBBER FLAT
TRLR-70X	2" BALL CLASS 3" ADJUSTABLE	205-14C BIAS (4)	14"X5"	3500lbs 3"	5 LUG	5 LEAF	4 POLE RUBBER FLAT
TRLR-70XF	2" BALL CLASS 3" ADJUSTABLE	205-14C BIAS (4)	14"X5"	3500lbs. 3"	5 LUG	5 LEAF	4 POLE RUBBER FLAT
TRLR-100XF	ADJUSTABLE 2-5/6 OPT 3" EYE	205-15C BIAS (4)	14"X5.5"	3500lbs 3"	5 LUG	5 LEAF	4 WIRE LOOM
TRLR-85/125	ADJUSTABLE 2-5/6 OPT 3" EYE	ST225/75R15D RADIAL (4)	14"x6"	(2)-6000lbs	6 LUG	7 LEAF	4 WIRE LOOM
TRLR-150XF	3" BALL EYE	750-16 E BIAS (4)	16"X7"	(2)-6000lbs	8 LUG	7 LEAF	4 WIRE LOOM
TRLR-220XF	3" EYE ADJUSTABLE	ST235/85R16E RADIAL(4)	16"X7"	(2)-7000lbs	8 LUG	Q FLEX	4 WIRE LOOM
TRLR-300XF	3" EYE ADJUSTABLE	ST235/85R16E RADIAL(6)	16"X7"	(2)-6000lbs	8 LUG	Q FLEX	4 WIRE LOOM
TRLR-400XF	3" EYE ADJUSTABLE	ST235/85R16E RADIAL(6)	16"X7"	(3)-7000lbs.	8 LUG	Q FLEX	4 WIRE LOOM
TRLR-600XF	5TH WHEEL	ST215/75R17.5H RADIAL (8)	16"X7"	(3)-10000lbs	8 LUG	7 LEAF	6 WIRE LOOM
TRLR-800AR	5TH WHEEL	ST215/75R17.5H RADIAL (8)	16"X7"	(3)-10000lbs	8 LUG	AIR-RIDE	6 WIRE LOOM

## Brakes

If your trailer has a braking system, the brakes should be inspected the first 200 miles of operation. This will allow the brake shoes and drums to seat properly. After the first 200 mile interval, inspect the brakes every 3,000 miles. If driving over rough terrain, inspect the brakes more frequently.

## Electric Brakes

Electrically actuated brakes (Figure 2) are similar to hydraulic brakes. The basic difference is that hydraulic brakes are actuated by an electromagnet.

Listed below are some of the advantages that electric brakes have over hydraulic brakes:

- Brake system can be manually adjusted to provide the corrected braking capability for varying road and load conditions
- Brake system can be modulated to provide more or less braking force, thus easing the brake load on the towing vehicle
- Brake system has very little lag time between the time the vehicle's brakes are actuated and the trailer's brakes are actuated
- Brake system can provide an independent emergency brake system

Proper synchronizing of the tow vehicle's and trailer braking system can only be accomplished by road testing. Brake lockup, grabbiness or harshness is due to lack of synchronization between the tow vehicle and the trailer

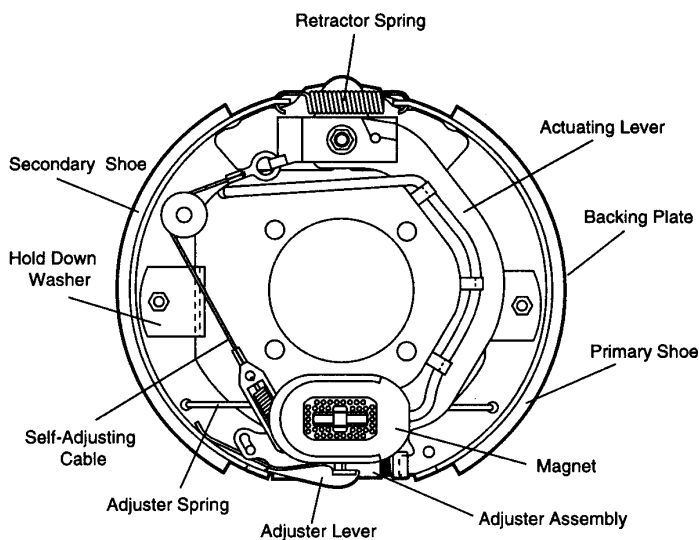
being towed or under-adjusted brakes.

Before any brake synchronizations adjustments can be made, the trailer brakes should be burnished-in by applying the brakes 20-30 times with approximately a 20 m.p.h. decrease in speed, e.g. 40 m.p.h. to 20 m.p.h. Allow ample time for brakes to cool between application. This allows the brake shoes to slightly be seated into the brake drum surface.

Figure 2 displays the major electric brake components that will require inspection and maintenance. Please inspect these components as required.

## Electric Brake Adjustment

1. Place the trailer on jack stands. Make sure the jack stands are placed on secure level ground.
2. Check the wheel and drum for free rotation.
3. Remove the adjusting hole cover from the adjusting slot at the bottom brake backing plate.
4. With a screwdriver or standard adjusting tool, rotate the star wheel of the adjuster assembly to expand the brake shoes.
5. Adjust the brake shoes outward until the pressure of the lining against the wheel drum makes the wheel difficult to turn.
6. Rotate the star wheel in the opposite direction until the wheel rotates freely with slight lining drag.
7. Replace the adjusting hole cover and lower the trailer to the ground.
8. Repeat steps 1 through 6 on the remaining brakes.

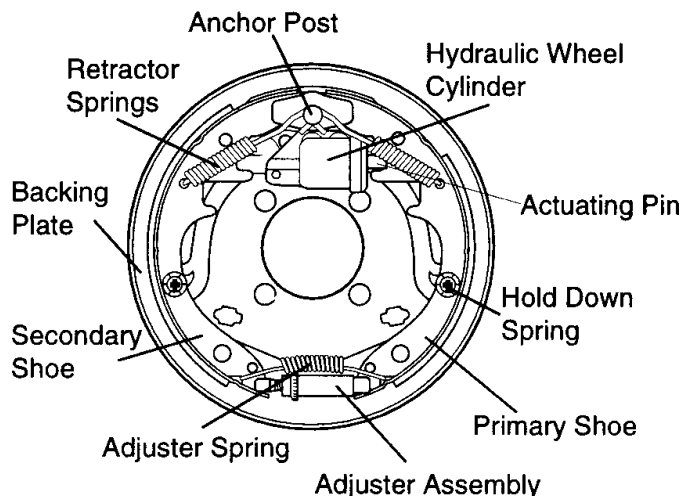


**Figure 2. Electrical Brake Components**

### Hydraulic/Air/Surge Brakes

Hydraulic brakes (Figure 3) should not require any special attention with the exception of routine maintenance such as shoe and lining replacement. These brakes can be adjusted in the same manner as electric brakes. Brake lines should be periodically checked for cracks, kinks, or blockage.

Figure 3 below displays the major hydraulic/air/surge brake components that will require inspection and maintenance. Please inspect these components as required using steps 1 through 6 as referenced in the electric brake adjustments section.



**Figure 3. Hydraulic Brake Components**

## Tires/Wheels/Lug Nuts

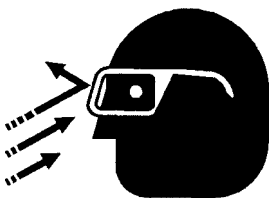
Tires and wheels are a very important and critical components of the trailer. When specifying or replacing the trailer wheels it is important the wheels, tires, and axle are properly matched.

### CAUTION:



DO NOT attempt to repair or modify a wheel. DO NOT install in inner tube to correct a leak through the rim. If the rim is cracked, the air

pressure in the inner tube may cause pieces of the rim to explode (break off) with great force and cause serious eye or bodily injury.

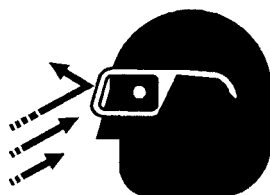


### Tire Wear/Inflation

Tire inflation pressure is the most important factor in tire life. Pressure should be checked cold before operation DO NOT bleed air from tires when they are hot. Check inflation pressure weekly during use to insure the maximum tire life and tread wear.

Table 2 (Tire Wear Troubleshooting) will help pinpoint the causes and solutions of tire wear problems.

### CAUTION:



#### NOTE

ALWAYS wear safety glasses when removing or installing force fitted parts. Failure to comply may result in serious injury.

TABLE 2. TIRE WEAR TROUBLESHOOTING

WEAR PATTERN		CAUSE	SOLUTION
	Center Wear	Over Inflation.	Adjust pressure to particular load per tire manufacturer.
	Edge Wear	Under Inflation.	Adjust pressure to particular load per tire manufacturer.
	Side Wear	Loss of camber or overloading.	Make sure load does not exceed axle rating. Align wheels.
	Toe Wear	Incorrect toe-in.	Align wheels.
	Cupping	Out-of-balance.	Check bearing adjustment and balance tires.
	Flat Spots	Wheel lockup & tire skidding.	Avoid sudden stops when possible and adjust brakes.

## Suspension

The leaf suspension springs and associated components (Figure 4) should be visually inspected every 6,000 miles for signs of excessive wear, elongation of bolt holes, and loosening of fasteners. Replace all damaged parts (suspension) immediately. Torqued suspension components as detailed in Table 3.

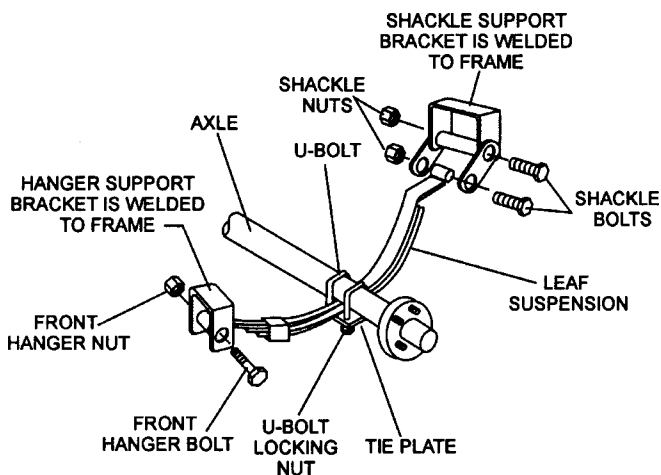


Figure 4. Major Suspension Components

**Table 3. Suspension Torque Requirements**

Item	Torque (Ft.-Lbs.)
3/8" U-BOLT	MIN-30 MAX-35
7/16" U-BOLT	MIN-45 MAX-60
1/2" U-BOLT	MIN-45 MAX-60
SHACKLE BOLT SPRING EYE BOLT	SNUG FIT ONLY. PARTS MUST ROTATE FREELY. LOCKING NUTS OR COTTER PINS ARE PROVIDED TO RETAIN NUT-BOLT ASSEMBLY.
SHOULDER TYPE SHACKLE BOLT	MIN-30 MAX-50

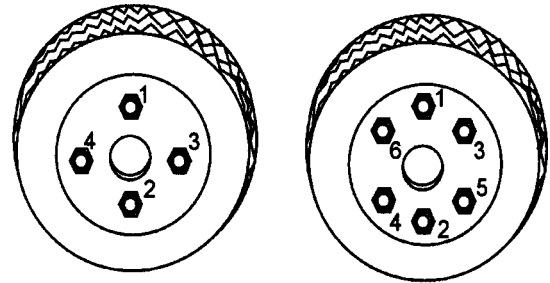
### Lug Nut Torque Requirements

It is extremely important to apply and maintain proper wheel mounting torque on the trailer. Be sure to use only the fasteners matched to the cone angle of the wheel. Proper procedure for attachment of the wheels is as follows:

1. Start all wheel lug nuts by hand.
2. Torque all lug nuts in sequence. See Figure 5. DO NOT torque the wheel lug nuts all the way down. Tighten each lug nut in 3 separate passes as defined by Table 4.
3. After first road use, retorque all lug nuts in sequence. Check all wheel lug nuts periodically.

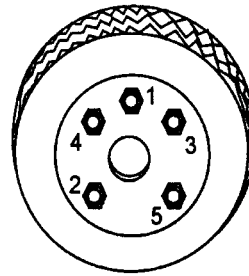
**Table 4. Tire Torque Requirements**

Wheel Size	First Pass FTLBS	Second Pass FTLBS	Third Pass FTLBS
12"	20-25	35-40	50-65
13"	20-25	35-40	50-65
14"	20-25	50-60	90-120
15"	20-25	50-60	90-120
16"	20-25	50-60	90-120

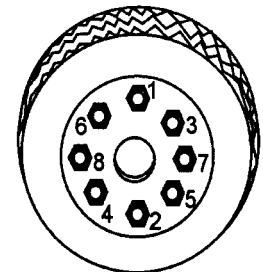


4-LUG NUTS

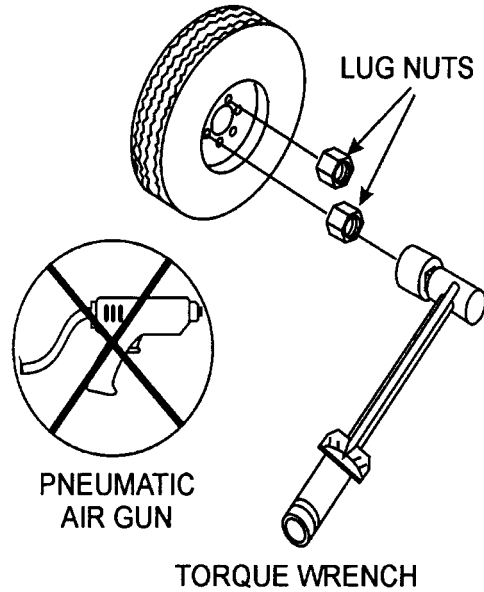
6-LUG NUTS



5-LUG NUTS



8-LUG NUTS



**Figure 5. Wheel Lug Nuts Tightening Sequence**

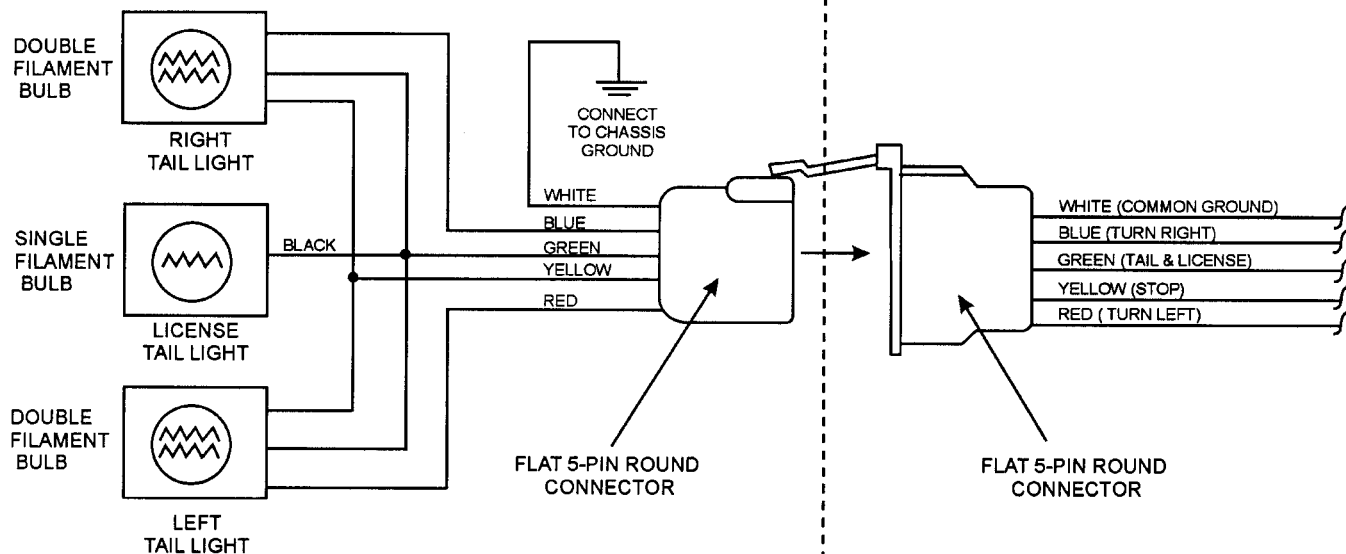
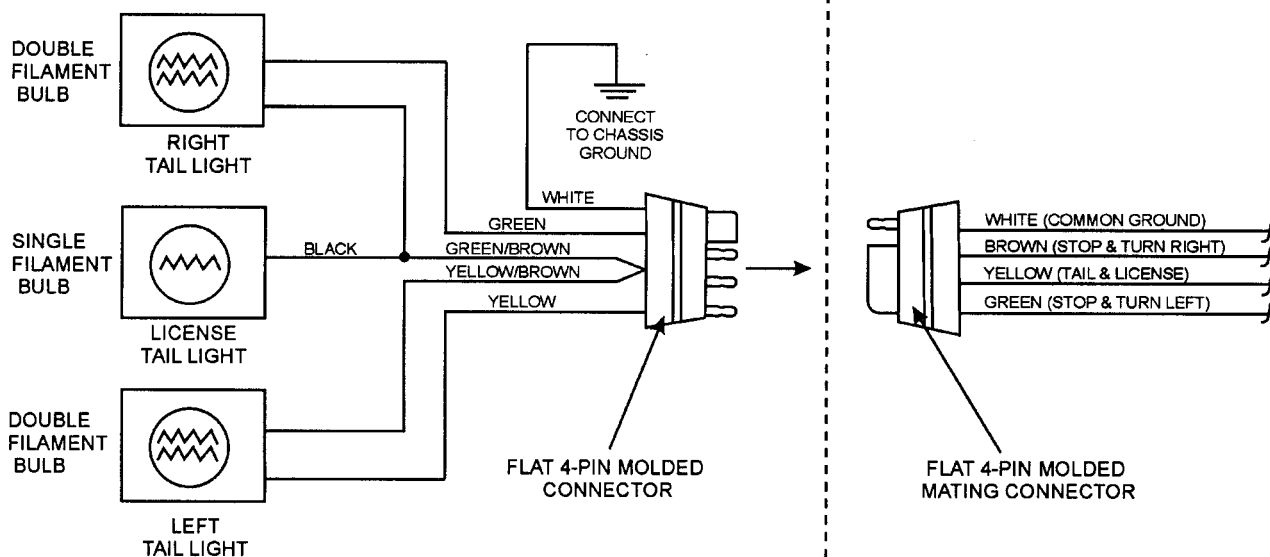
**NOTE**

NEVER use an pneumatic air gun to tighten wheel lug nuts.

# DCA-400SSK — TRAILER-WIRING DIAGRAM

## TRAILER SIDE

## TOWING VEHICLE SIDE



**Table 5. Electric Brake Troubleshooting**

Symptom	Possible Cause	Solution
No Brakes or Intermittent Brakes	Any open circuits or broken wires?	Find and correct.
	Any short circuits?	Find and correct.
	Faulty controller?	Test and correct.
	Any loose connections?	Find and repair.
	Ground wire secure?	Find and secure.
Weak Brakes or Brakes Pull to One Side	Grease or oil on magnets or linings?	Clean or replace.
	Connections corroded?	Clean and correct cause of corrosion.
	Brake drums scored or grooved?	Machine or replace.
	Brakes synchronized?	Correct.
Locking Brakes	Brake components loose, bent or broken?	Replace components.
	Brake drums out-of-round?	Replace.
Noisy Brakes	System lubricated?	Lubricate.
	Brake components correct?	Replace and correct.
Dragging Brakes	Bearings of the wheel adjusted?	Adjust.

**Table 6. Hydraulic Brake Troubleshooting**

Symptom	Possible Cause	Solution
No Brakes	Brake line broken or kinked?	Repair or replace.
Weak Brakes or Brakes Pull to One Side	Brake lining glazed?	Reburnish or replace.
	Trailer overloaded?	Correct weight.
	Brake drums scored or grooved?	Machine or replace.
	Tire pressure correct?	Inflate all tires equally.
	Tires unmatched on the same axle?	Match tires.
Locking Brakes	Brake components loose, bent or broken?	Replace components.
	Brake drums out-of-round?	Replace.
Noisy Brakes	System lubricated?	Lubricate.
	Brake components correct?	Replace and correct.
Dragging Brakes	Brake lining thickness correct or in right wrong position?	Install new shoes and linings.
	Enough brake fluid or correct fluid?	Replace rubber parts fill with dot4 fluid.

# DCA-400SSK — OPERATION AND SAFETY DECALS

## Machine Safety Decals

The DCA-400SSK generator is equipped with a number of safety decals. These decals are provided for operator safety and maintenance information. The illustration below and on the preceding pages show the decals as they appear on the machine. Should any of these decals become unreadable, replacements can be obtained from your dealer.

### GENERAL

**HANDLING PROCEDURES**

1. CHECK TO OPERATING  
Prior to operating the engine be sure to check the following items to prevent trouble and accidents:

- (1) Check lubricating oil, cooling water and diesel fuel.
- (2) Check the tension of the fan-belt and charging generator driving belt.
- (3) Check the CIRCUIT BREAKER is turned "OFF".
- (4) Set the voltage change-over board to the rated voltage (only Dual voltage type).

2. STARTING AND OPERATING

- (1) Turn the battery switch to "ON" position.
- (2) Turn the STARTER SWITCH to "PREHEAT" position for 1.0 ~ 30 seconds.  
Press the STARTER SWITCH to "START" POSITION to start the engine.  
When the engine starts, release the STARTER SWITCH.
- (3) Warm-up the engine for about 5 minutes.
- (4) Rotate the THROTTLE HANDLE to "HIGH SPEED" and adjust the engine speed according to the following table.

No-load operating speed	
50 Hz operation	Approx. 52.5 Hz (1575 rpm)
60 Hz operation	Approx. 62.5 Hz (1875 rpm)

S-2763

P/N 0800655603

### CONTROL BOX GROUP

**SAFETY INSTRUCTIONS**

Improper operation of this machine can cause severe injury or death.

- Read the instruction manual carefully before operating or servicing.

This machine should only be operated by a person with sufficient knowledge and skill to ensure safe operation.

High voltage circuits are located inside the output terminal cover and control panel.

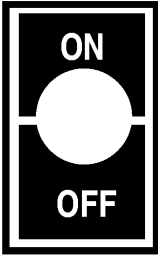
- Close the cover and control panel before operating.

Moving parts and hot surfaces are contained within the enclosure.

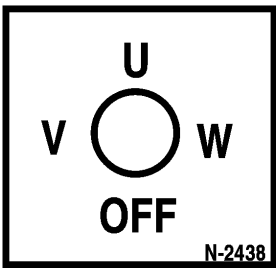
- Close all doors and lock them before operating.

C2510000

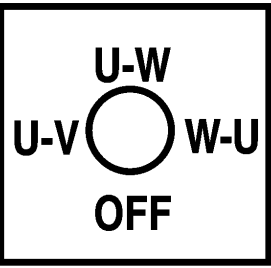
P/N C255100004



P/N 0800520100




N-2438  
P/N 0800520904



P/N 0800520814

## WHISPERWATT 400



**MQ POWER CORP.**  
**WHISPERWATT 400**  
**400 KVA AC GENERATOR**  
**MODEL DCA-400SSK**

C36110110

P/N C0561103403

CIRCUIT BREAKER


S-3031

P/N 08406 24504

PILOT LAMP

S-3033

P/N 0840624704



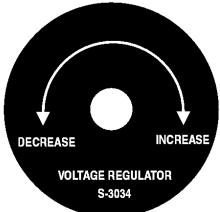
**WARNING**

**ELECTRIC SHOCK HAZARD**

- Do not touch internal wiring or connections while this machine is operating.
- Turn power off before servicing.

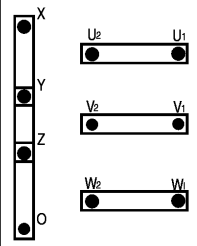
B93110060

P/N B9531100604

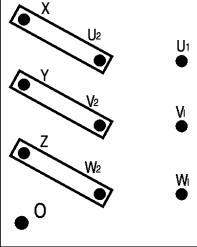


P/N 0840624804

SETTING FOR OUTPUT VOLTAGE (240V)



(480V)



Tighten hexagon head bolts securely.  
C0510000

P/N C0551000903

**ENGINE & RADIATOR GROUP**



**⚠ WARNING**  
**ELECTRIC SHOCK HAZARD**  
 • A ways complete the grounding path from the ground terminal on this genset to an external grounding source. See nstruct on manua for details.

B91110040

P/N B9511100404



**⚠ WARNING**  
**HOT COOLANT can cause severe burns.**  
 • Do not remove cap if radiator is hot.

B90410010

P/N B9504100104



P/N 63606 10304

**ENGINE OPERATING PANEL GROUP**

**PREHEAT LAMP**  
 S-3036

P/N 0840625004



P/N C0551000704

**BATTERY SWITCH**

**DON'T TURN THE SWITCH OFF DURING OPERATION**

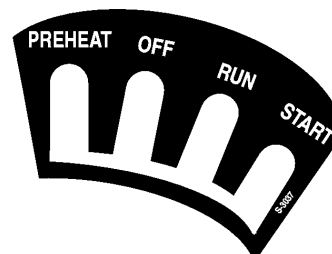
C05100050

P/N C0551000504

**STOP BUTTON**

C0510080

P/N C0551000804



P/N 0840625104

# DCA-400SSK — OPERATION AND SAFETY DECALS

## OUTPUT TERMINAL GROUP

**GROUND**  
S-2635

P/N 0840614104

**DANGER**  
**HIGH VOLTAGE**  
S-2731

P/N 08040619904

**240/139 VOLT**  
C15100040

P/N C1551000404

**WARNING**  
**ELECTRIC SHOCK HAZARD**

- Do not touch output terminals while this machine is operating.
- Turn power off before servicing.

B93110050

P/N B9531100504

**WARNING**  
**ELECTRIC SHOCK HAZARD**

- Always complete the grounding path from the ground terminal on this genset to an external grounding source. See instruction manual for details.

B91110040

P/N B9511100404

**WARNING**

- Before connecting this generator to any building's electrical system, a licensed electrician must install an isolation (transfer) switch.
- Serious injury or death may result without this transfer switch.

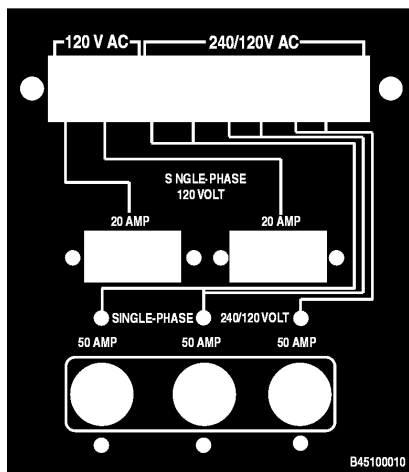
B91110030

P/N B9511100304

3-Phase output terminal  
Keep the loads balancing when using plural single loads.

C05100040

P/N C0551000404

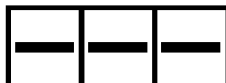


P/N B4551000103

## BATTERY GROUP



P/N 08006 89404



P/N 08006 89504

## MUFFLER GROUP

**WARNING**

- Only operate machine in well ventilated areas.
- Do not inhale exhaust gases.

**DANGEROUS GAS**

Only qualified personnel should install, use, or service this equipment.

P/N B950420004

FUEL TANK GROUP



P/N 6360620004



P/N B9504500004



P/N 1320620904

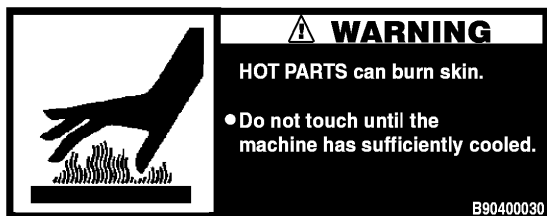
ENCLOSURE GROUP



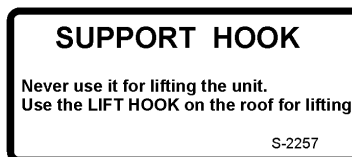
P/N 0840625902



P/N 1320610603



P/N B9504000304



P/N 13206 21504

# DCA-400SSK — SPECIFICATIONS

Table 7. Specifications		
Generator Specifications		
Model	DCA-400SSK	
Type	Revolving field, self ventilated, open protected type synchronous generator	
Armature Connection	Star with Neutral	
Phase	3	
Standby Output	440 KVA (352.0 KW)	
Prime Output	400 KVA (320.0 KW)	
Voltage	240V or 480V	
Frequency	60 Hz	
Speed	1800 rpm	
Power Factor	0.8	
Aux. AC Power	Single Phase, 60 Hz	
Voltage	120 V	
Output	4.8 KW (2.4 KW x 2)	
Engine Specifications		
Model	KOMATSU SA6D140E-2	
Type	4 Cycle, water-cooled, direct injection, turbo-charged with after-cooler	
No. of Cylinders	6 cylinders	
Bore x Stroke	5.5 in. x 6.5 in. (140 mm x 165mm)	
Rated Output	478 HP/1800 rpm	
Displacement	930 cu. in. (15240 cc)	
Starting	Electric	
Coolant Capacity	16.9 gal. (58 liters)	
Lube Oil Capacity	19.5 gal. (74 liters)	
Fuel Consumption	20.4gal. (77.5L)/hr at <b>full load</b>	15.8gal.(59.8L)/hr at <b>3/4 load</b>
	11.0gal.(41.6L)/hr at <b>1/2 load</b>	6.6gal.(25.0L)/hr at <b>1/4 load</b>
Battery	12V- 200 AH x 2	
Fuel	#2 Diesel Fuel	

## DCA-400SSK FAMILIARIZATION

### Generator

The MQ Power Model DCA-400SSK is a 320 kW **generator** that has been designed as a high quality portable (requires a trailer for transport) power source for telecom sites, lighting facilities, power tools, submersible pumps and other industrial and construction machinery.

### Engine Control Panel

The "Engine Control Panel" is provided with the following:

- Tachometer
- Water Temperature Gauge
- Oil Pressure Gauge
- Charging Ammeter Gauge
- Engine Warning Lamp Module
- Engine Speed Switch
- Pre-Heat Button
- Pre-Heat Lamp
- Emergency Stop Button
- Battery Switch

### Generator Control Panel

The "Generator Control Panel" is provided with the following:

- Output Voltage Adjustment Knob
- Frequency Meter (Hz)
- AC Ammeter (Amps)
- AC Voltmeter (Volts)
- AC Wattmeter (Kw)
- Ammeter Change-Over Switch
- Voltmeter Change-Over Switch
- Panel Light
- Panel Light Switch
- MPEC Module
- Pilot Lamp

### Output Terminal Panel

The "Output Terminal Panel" is provided with the following:

- Two 120V GFCI receptacles, 20 amp
- Three 240/139V output receptacles, 50 amp
- Two 120V input receptacles, 20 amp
- 3 Load Circuit Breakers 265V @65 amps
- 2 Load GFCI Circuit Breakers 265V@ 20amps

### Control Box

The "Control Box" is provided with the following:

- Main Circuit Breaker 1060 amps
- Over-Current Relay
- High Idle Adjust Trimmer

### Microprocessor Controlled Alarm System

The DCA-400SSK generator is equipped with various alarms and LED status indicators. These alarms and status indicators are provided to add safety to the generator when operating under normal conditions. The DCA-400SSK generator is designed to shutdown in the event of low oil, high coolant temperature, low battery and other operation conditions that may cause severe damage to the generator.

### Open Delta Excitation System

The DCA-400SSK generator is equipped with the state of the art "**Open-Delta**" excitation system. The open delta system consist of an electrically independent winding wound among stationary windings of the AC output section.

There are four leads: A, B, C and D. During light loads, the power to the **Automatic Voltage Regulator** (AVR) is supplied from the leads parallel connections of B&C. When loads increase, the AVR switches and accepts power from leads A&D. The output of leads A&D increase proportionally with load. This of adding the voltages to each phase provides better voltage response during heavy loads.

The connections of the AVR to the AC output windings are for sensing only. No power is required from these windings.

The open-delta design provides virtually unlimited excitation current, offering maximum motor starting capabilities. The excitation does not have a "**fixed ceiling**" and responds according the demands of the required load.

## Engine

The **DCA-400SSK** is powered by a 4 cycle, water cooled, turbocharged KOMATSU Model SA6D140E-2 *diesel* engine. This engine is designed to meet every performance requirement for the generator. Reference Table 7, page 23 for engine specifications.

In keeping with Multiquip's policy of constantly improving its products, the specifications quoted herein are subject to change without prior notice.

The basic controls and indicators for the DCA-400SSK generator are addressed on the following pages.

### Electronic Governor System

The electronic governor system is made up of two parts, an electronic controller that monitors frequency variation as the load increases and decreases and an electronic actuator that controls the engine throttle. The frequency is regulated at  $\pm 0.25$  to help protect sensitive equipment. Engine

### Jacket Water Heater

The jacket water heater is a 2000-watt heater designed to keep the coolant warm in the engine block for fast starts and load acceptance. The heater is thermostatically controlled and once an acceptable engine temperature is achieved it will cycle on and off, operating only about 1/3 of the time, which makes it more efficient than the direct block type heater. It is designed to keep the engine coolant between 100 and 120 degrees Fahrenheit.

Under normal conditions, 20 to 15 minutes is required to raise the engine temperature of a cold engine to 100 degrees Fahrenheit.

## CAUTION :



**ALWAYS** unplug the jacket water heater before servicing.

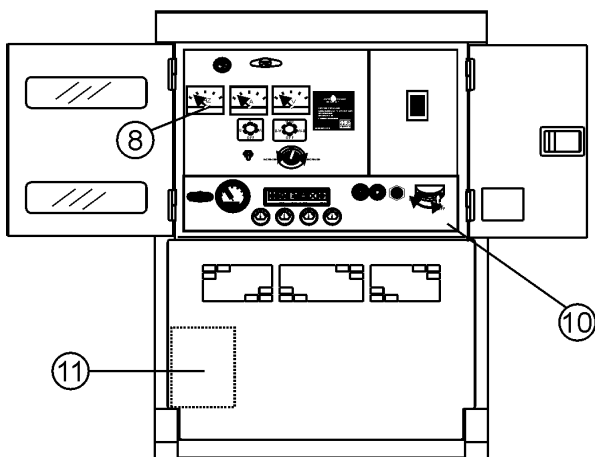
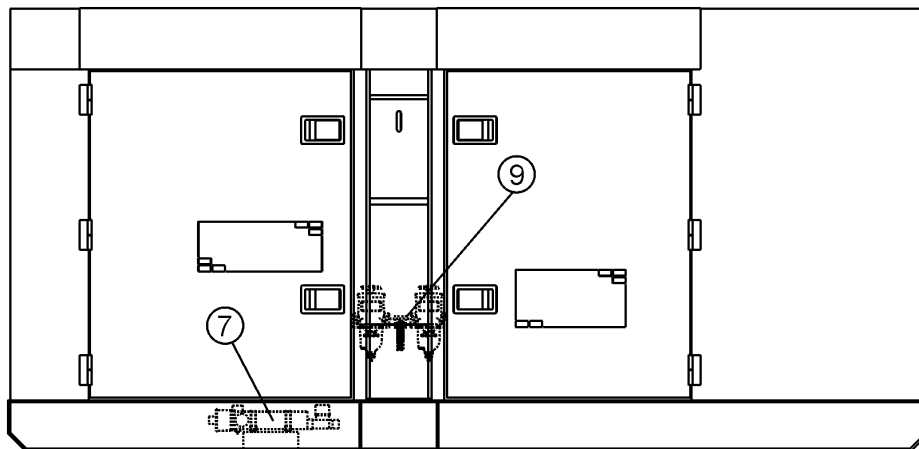
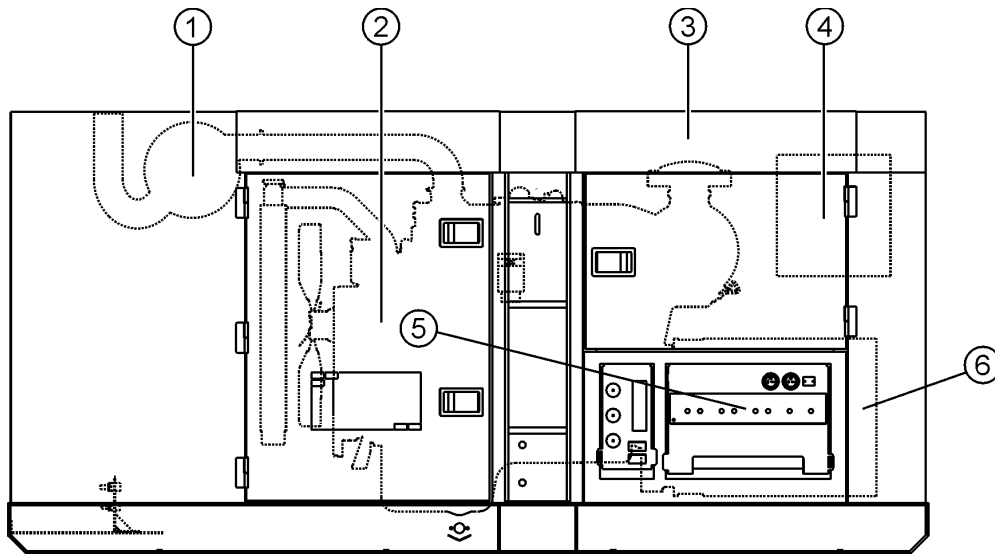
### Battery Charger

The battery charger will operate in a 'BOOST' mode until the battery's current acceptance falls to 70% of the charger's rating. The charger will then go into a 'FLOAT' mode, where it discharges a lower voltage until an AC failure, or the battery is discharged.

#### NOTE:

The jacket water heater can be serviced if not functioning properly.

# DCA-400SSK — MAJOR COMPONENTS



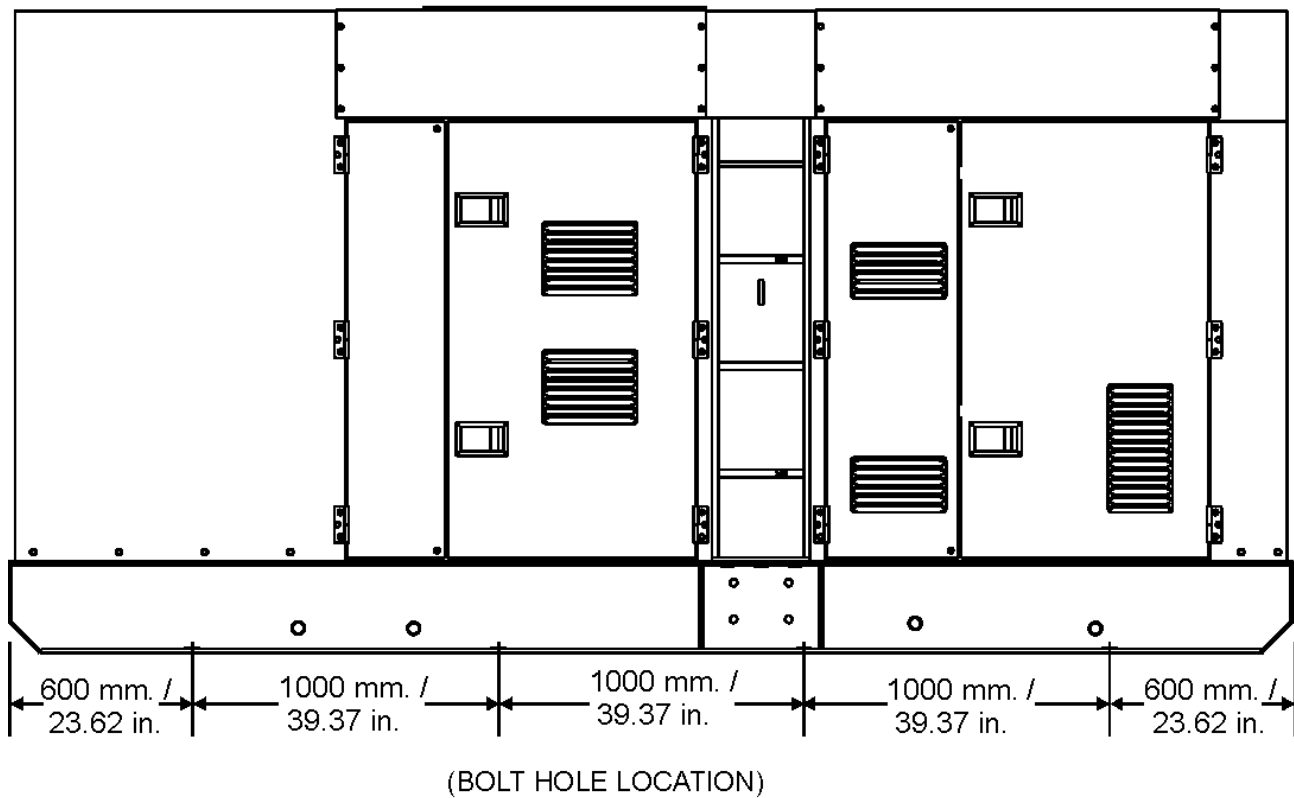
ITEM	DESCRIPTION
1	MUFFLER ASSEMBLY
2	ENGINE & RADIATOR ASSEMBLY
3	ENCLOSURE ASSEMBLY
4	CONTROL BOX ASSEMBLY
5	OUTPUT TERMINAL ASSEMBLY
6	GENERATOR ASSEMBLY
7	WATER HEATER ASSEMBLY
8	CONTROL PANEL ASSEMBLY
9	FUEL-WATER SEPARATOR ASSEMBLY
10	ENGINE OPERATING PANEL ASSEMBLY
11	BATTERY

Figure 7. Major Components



# DCA-400SSK — DIMENSIONS (TOP AND SIDE)

## SIDE VIEW



## TOP VIEW

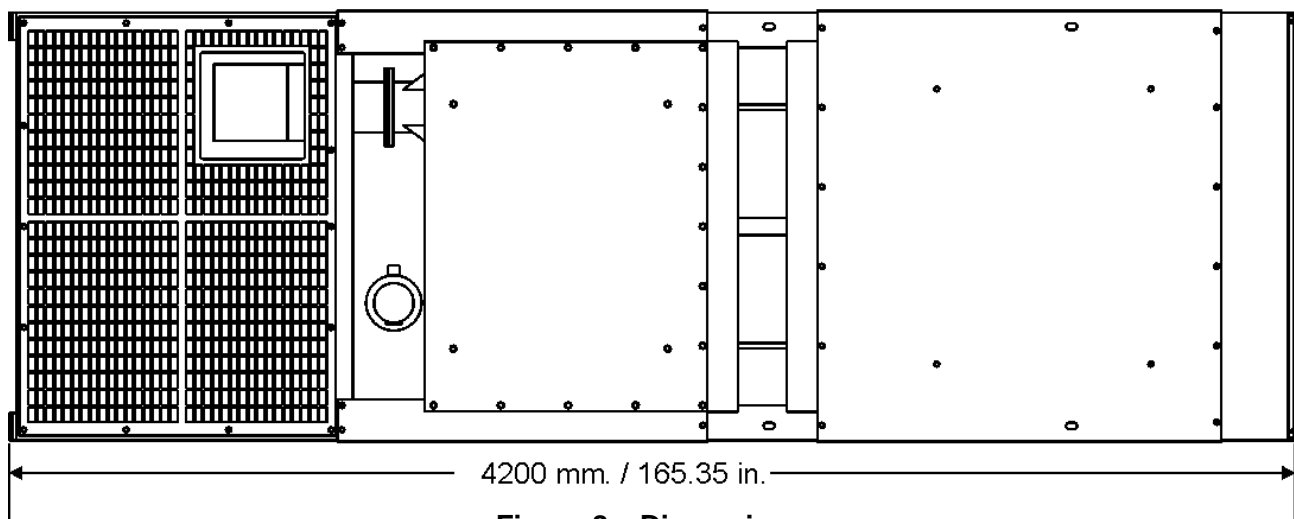


Figure 8a. Dimensions

# DCA-400SSK — DIMENSIONS (FRONT AND REAR)

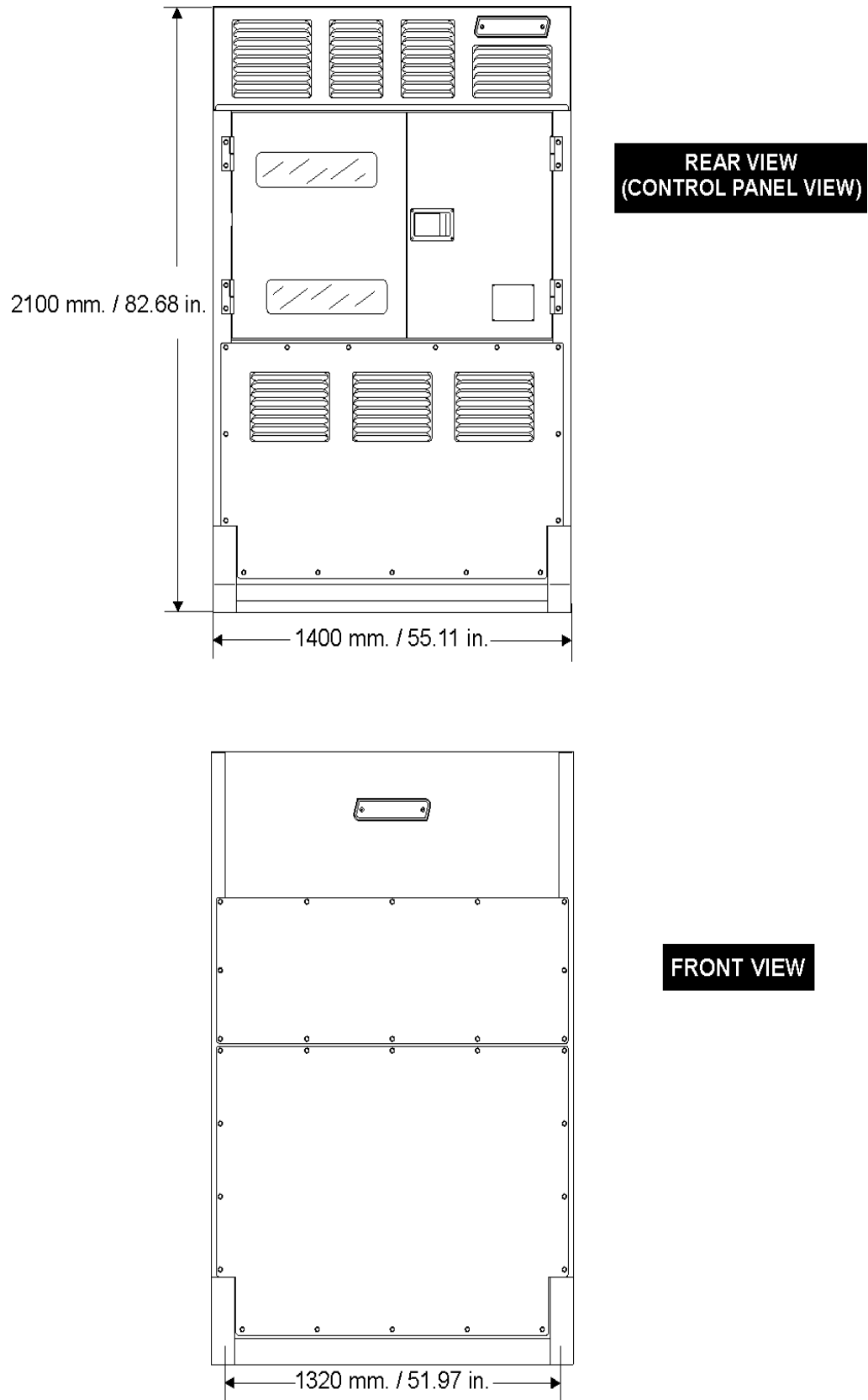
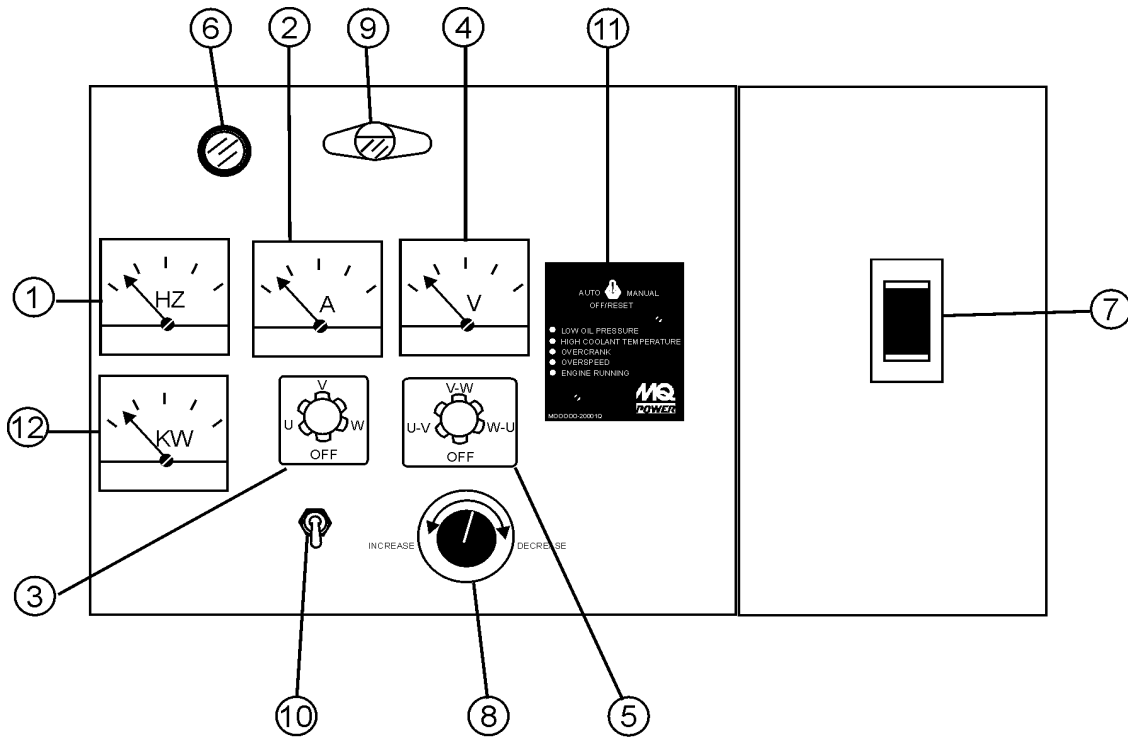


Figure 8b. Dimensions



1	FREQUENCY METER
2	AC AMMETER
3	AMMETER CHANGE-OVER SWITCH
4	AC VOLTMETER
5	VOLTMETER CHANGE-OVER SWITCH
6	PILOT LAMP
7	CIRCUIT BREAKER
8	VOLTAGE REGULATOR
9	PANEL LIGHT
10	PANEL LIGHT SWITCH
11	MICROPROCESSOR ENGINE CONTROLLER
12	KILOWATT METER

Figure 9. Control Panel

The definitions below describe the controls and functions of the DCA-400SSK " **Control Panel**" (Figure 9).

1. **Frequency Meter** – Indicates the output frequency in hertz (Hz). Normally 60 Hz  $\pm$ 1 Hz .
2. **AC Ammeter** – Indicates the amount of current the load is drawing from the generator.
3. **Ammeter Change-Over Switch** – This switch allows the AC ammeter to indicate the current flowing to the load connected to any phase of the output terminals, or to be switched off.
4. **AC Voltmeter** – Indicates the single phase output voltage present at the UVW terminals.
5. **Voltmeter Change-Over Switch** – This switch allows the AC voltmeter to indicate phase to phase voltage between any two phases of the output terminals or to be switched off.
6. **Pilot Lamp** – Indicates that the generator is working properly.
7. **Main Circuit Breaker** – This three-pole, 1060 amp main breaker is provided to protect the UVW voltage output terminals from overload.
8. **Voltage Regulator Control** – Allows manual adjustment of the generator's output voltage.
9. **Panel Light** – Normally used in dark areas or at night time. When activated, panel lights will illuminate. When the generator is not in use be sure to turn the panel light switch to the OFF position.
10. **Panel Light Switch** – When activated will turn on control panel light.
11. **MPEC – Microprocessor Engine Control Module** – (MPEC) has a vertical row of status LED's (Figure 10), that when lit, indicate that an engine malfunction (fault), has been detected. When a fault has been detected the MPEC will evaluate the fault and if the fault is major will shutdown the generator.



**Figure 10. MPEC Module**

During **cranking cycle** , The MPEC will attempt to crank the engine for 10 seconds before disengaging.

If the engine does not engage (start) by the third attempt, the engine will be shutdown by the MPEC's " Over Crank Protection" mode. If the engine engages at a speed (RPM's) that is not safe, the MPEC will shutdown the engine by initializing the "Over Speed Protection" mode.

Also the MPEC will shutdown the generator in the event of low oil pressure, high coolant temperature, low coolant level, and loss of magnetic pickup. These conditions can be observed by monitoring the LED status indicators on the front of the MPEC module.

**A. Off/Manual/Auto Switch** – This switch controls the running of the generator. If this switch is left in the "OFF" position, the generator will not run. When this switch is set to the **manual** position, the generator will start immediately.

If the generator is to be connected to a building's AC power source via a transfer switch (isolation), place the switch in the **auto** position. In this position the generator will monitor the AC line output from the building's power source.

**B. Low Oil Pressure** – Indicates the engine pressure has fallen below 15 psi. The oil pressure is detected using variable resistive values from the oil pressure sending unit. This is considered a **major** fault.

**C. High Coolant Temperature** – Indicates the engine temperature has exceeded 215°F. The engine temperature is detected using variable resistive values from the temperature sending unit. This is considered a **major** fault.

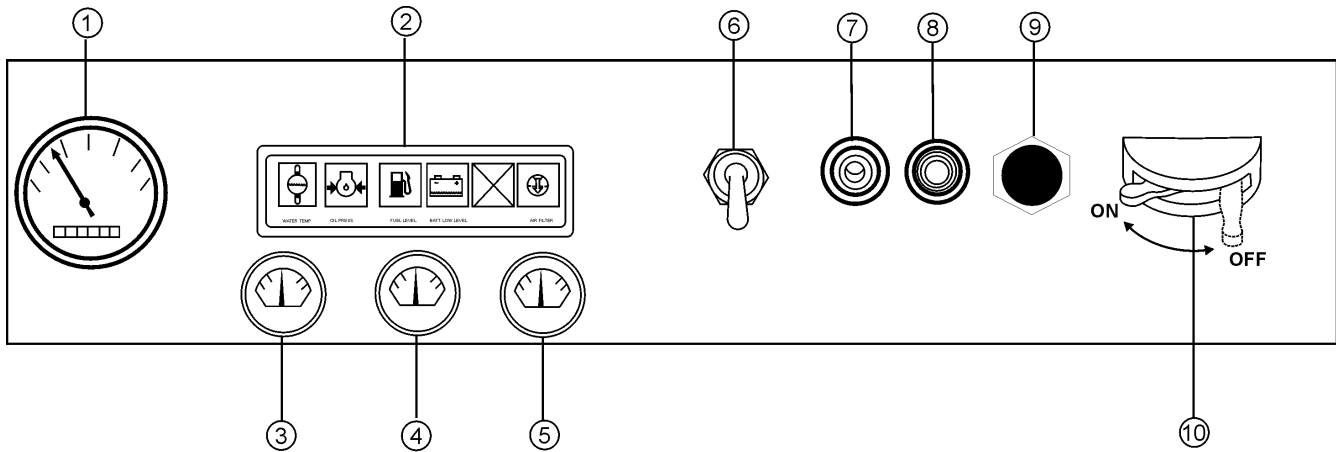
**D. Overcrank Shutdown** – Indicates the unit has attempted start a pre- programmed number of times, and has failed to start. The number of cycles and duration are programmable. Typical programmable start settings is 3 cycles with a 10 second duration. This is considered a **major** fault.

**E. Overspeed Shutdown** – Indicates the engine is running at an unsafe speed. This is considered a **major** fault.

**F. Engine Running** – Indicates the engine is running at a safe operating speed.

12. **AC Wattmeter** – Indicates the output power of the generator.

# DCA-400SSK — ENGINE OPERATING PANEL



1	TACHOMETER
2	ENGINE WARNING DISPLAY (LED) MODULE
3	OIL PRESSURE GAUGE
4	WATER TEMPURATURE GAUGE
5	CHARGING AMMETER GAUGE
6	SPEED SWITCH
7	PREHEAT LAMP
8	PREHEAT SWITCH
9	EMERGENCY STOP BUTTON
10	BATTERY SWITCH

**Figure 11. Engine Operating Panel**

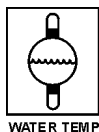
# DCA-400SSK — ENGINE OPERATING PANEL

The definitions below describe the controls and functions of the DCA-400SSK " **Engine Operating Panel** " (Figure 11).

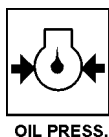
1. **Tachometer** – Indicates engine speed in RPM's for 60 Hz operation. This meter should indicate 1800 RPM's when the rated load is applied. In addition a built in hour meter will record the number of operational hours that the generator has been in use.

2. **Engine Warning Display Module** – This module displays the following engine failures:

A. **Overheat Lamp** – This lamp goes ON when the cooling water temperature rises abnormally. If the lamp goes ON during normal operation of the generator, the emergency shutdown device will stop the engine automatically.



B. **Low Oil Pressure Lamp** – During normal operation of the generator this lamp should remain OFF. When the Auto-OFF/Reset-Manual switch is set to the "Manual" position to start the engine, the lamp will be lit. After the oil pressure rises after start-up the lamp will go OFF. If this lamp is ever lit (ON) during normal operation of the generator, the emergency shutdown device will stop the engine automatically.



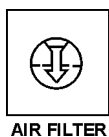
C. **Low Fuel Level Lamp** – When this lamp is ON, it is time to stop the engine and add fuel. Remember to let the engine cool before adding fuel.



D. **Low Battery Fluid Lamp** – This lamp goes ON when the battery fluid is low. If this lamp goes ON during normal operation of the generator, stop the engine and fill the battery with distilled water to the specified level.



E. **Clogged Air Filter Lamp** – This lamp goes ON when the air filter is clogged. If this lamp goes ON during normal operation of the generator, stop the engine and replace the air filter.



3. **Oil Pressure Gauge** – During normal operation this gauge should read in the "GREEN" zone. When starting the generator the oil pressure may read a little bit higher, but after the engine warms up the oil pressure should return to the green zone.

4. **Water Temperature Gauge** – During normal operation this gauge should read in the "GREEN" zone.

5. **Charging Ammeter Gauge** – Indicates the current being supplied by the engine's alternator which provides current for generator's control circuits and battery charging system.

6. **Speed Switch** – Use this switch to adjust the speed of the engine.

7. **Pre-Heat Lamp** – Indicates that the glow plugs of the diesel engine are hot and the engine is ready to be started.



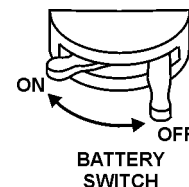
8. **Pre-Heat Button** – Press hold this button until the preheat lamp is lit (ON).



9. **Emergency Stop Button** – Push this button inward to stop the engine in the event of an emergency. **DO NOT** use this button as a means of stopping the engine.



10. **Battery Switch** – This switch should be set to the ON position during normal operation. When the engine has been stop, place this switch in the OFF position. **DO NOT** turn this switch during normal operation, it could cause damage to the electrical equipment



# DCA-400SSK — OUTPUT TERMINAL PANEL OVERVIEW

## OUTPUT TERMINAL FAMILIARIZATION

The "Output Terminal Panel" is provided with the following:

- Two 120V GFCI receptacles, 20 amp
- Three 240/139V output receptacles, 50 amp
- Two 120V input receptacles, 20 amp (optional)
- 3 Load Circuit Breakers 265V @65 amps
- 2 Load GFCI Circuit Breakers 265V @ 20amps

## Control Box

The "Control Box" is provided with the following:

- Main Circuit Breaker 1000 amps
- Over-Current Relay

## Output Terminal Panel

The Output Control Panel (See Figure 14) is located on the right hand side (left from control panel) of the generator. The UVWO lugs are protected by a face plate cover that can be secured in the close position by a pad lock. (See Figure 12).

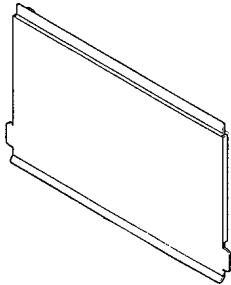


FIGURE 12. Output Terminal Cover

## 120 Volt Receptacle

Two GFCI Duplex Nema 5-20R (120V, 20 Amp) receptacle is provided on the output terminal. This receptacle can be used anytime the generator is in operation. The receptacle is controlled by the circuit breaker located on the control panel.

Pressing the reset button resets the receptacle after being tripped. Pressing the "Test Button" (See Figure 13) in the center of this receptacle will check the GFCI function. The receptacle should be tested at least once a month.

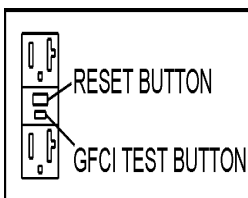


FIGURE 13. GFCI Test Button

## Connecting Load

Loads can be connected to the generator by the UVWO Lugs or the convenience receptacles. (See Figure 14). Make sure to read the operation manual before attempting to connect a load to the generator.

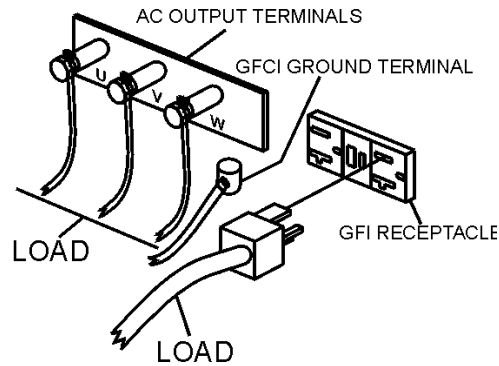


FIGURE 14. Connecting Load

## Circuit Breakers

To protect the generator from an overload, a 3-pole, 1000 amp, **main** circuit breaker is provided to protect the UVW output terminals from overload. In addition two single-pole, 20 amp **GFCI** circuit breakers are provided to protect the GFCI receptacles from overload. Three 50 amp **load** circuit breakers have also been provided to protect the load side of the generator from overload. Make sure to switch **ALL** circuit breakers to the "OFF" position prior to starting the engine.

## Maximum Output

The entire load connected to the UVWO Lugs, all four slots in the duplex receptacles, and the must not exceed 352 kW in standby or 320 in prime output.

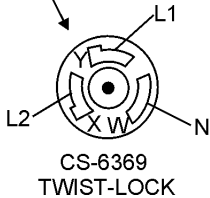
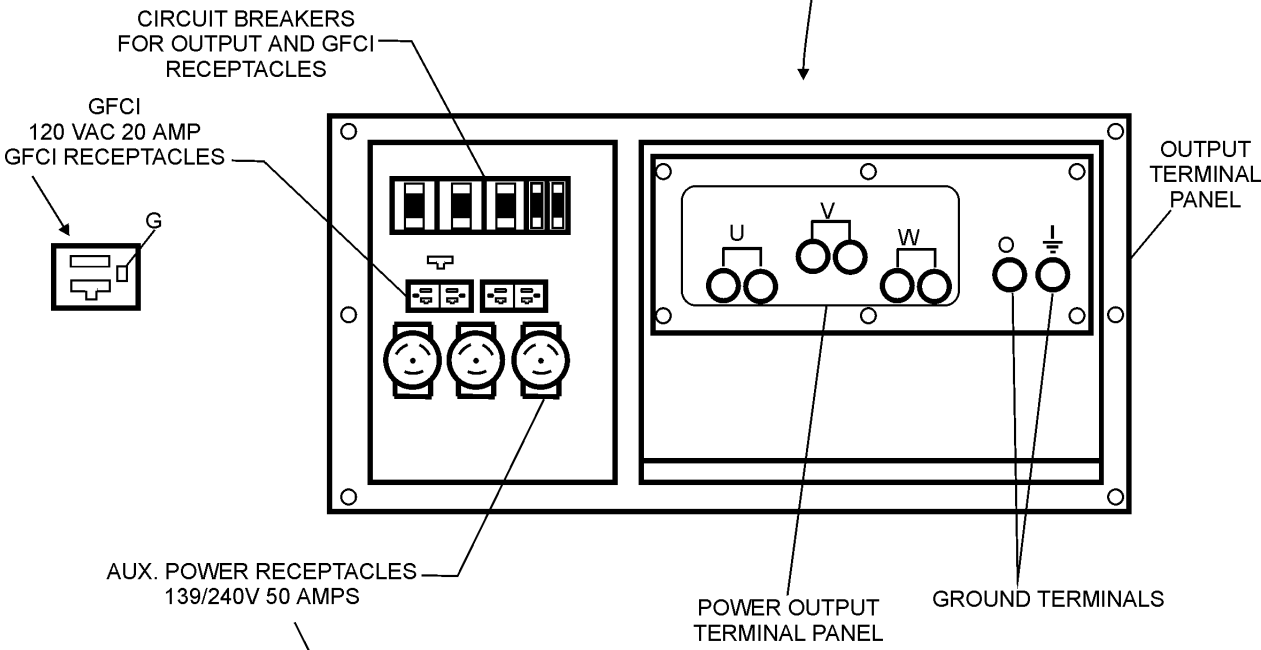
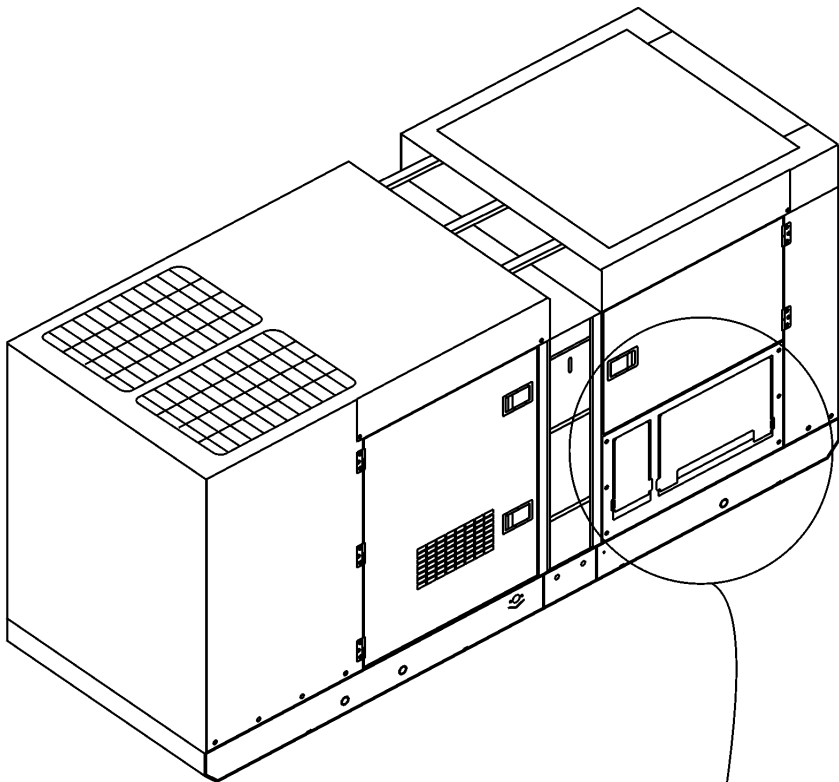
## Twist Lock Dual Voltage Receptacles

Three CS-6369 auxiliary power receptacles have been provided to supply 208/120V. The voltage regulator knob on the control panel may need to be used to adjust the voltage to 208 or 416V.

## Input Receptacles

Two 120 volt, 20 amp input receptacles are provided to supply power to accessories, such as the battery charger (optional) or jacket water heater (optional).

# DCA-400SSK — OUTPUT TERMINAL PANEL OVERVIEW



**FIGURE 15. Output Terminal Panel**

**NOTE**

Legs 0 and Ground are considered Bonded Grounds.

# DCA-400SSK — OUTPUT TERMINAL PANEL OVERVIEW

## Output Terminal Panel Available Voltages

A wide range of voltages are available to supply load to many different applications. Voltages may be selected by using the voltage change-over board and how you hookup your hard wire connection to the generator. To obtain some of the voltages listed, fine adjustment with the Voltage Regulator on the control panel is necessary. See the Table 8 for a list of available voltages the generator is able to supply.

TABLE 8. VOLTAGES AVAILABLE						
MODEL	DCA400SSK					
3 PHASE VOLTAGE (RECONNECTABLE)	208 VOLT	220 VOLT	240 VOLT	416 VOLT	440 VOLT	480 VOLT
SINGLE PHASE (ADJUSTABLE)	120 VOLT	127 VOLT	139 VOLT	240 VOLT	254 VOLT	277 VOLT

## CAUTION :



**NEVER** attempt to change the Voltage Change-over board while the engine is engaged.

## Over Current Relay

An over current relay is connected to the circuit breaker. In an over current situation, both the circuit breaker and the over current relay may trip. If the circuit breaker can not be reset, the reset button on the over current relay must be pressed. The over current relay is located in the control box.

## Maximum Amps

The following table show the maximum amps the entire generator can provide. Do not exceed the maximum amps listed. (See Table 9)

**Table 9. Maximum Amps**

Model:	DCA400SSK
Rated Voltage	Maximum Amps
Single Phase 120 Volt	888.9 amps (4 wire)
Single Phase 240 Volt	444.4 amps (4 wire)
Three Phase 240 Volt	962.3 amps
Three Phase 480 Volt	481.1 amps

# DCA-400SSK — OUTPUT TERMINAL PANEL OVERVIEW

## How to read the output terminal gauges.

The gauges and knobs on the control panel **DO NOT** effect the generator output in any fashion. They are there to simply help the operator observe how much power is being supplied produced at the UVWO legs.

To read the output of the W-U legs, for example, place the AC Voltmeter Change-over switch to the W-U position and the AC ammeter Change -over Switch to the U or W position to read the output on the selected leg.

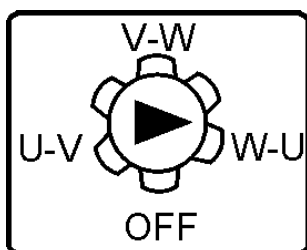


FIGURE 16. AC Voltmeter Change-over switch (Reading the W-U leg on the output terminal panel)

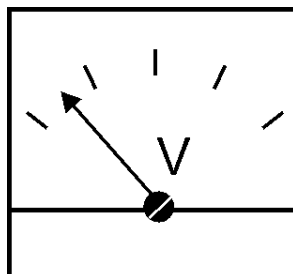


FIGURE 17. AC Voltmeter Gauge (Volt reading on W-U Lug)

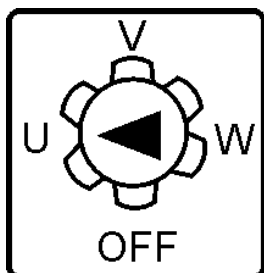


FIGURE 18. AC Ammeter Change-over Switch (Reading the U leg on the output terminal panel)

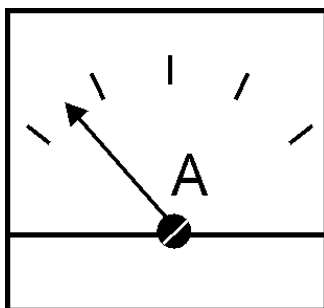


FIGURE 19. AC Ammeter (Amp reading on U lug)

# DCA-400SSK — OUTPUT TERMINAL PANEL OVERVIEW

## Voltage Change-over Board

The voltage change-over board changes the available voltages of the output terminal panel UVWO lugs. The voltage change-over board is located on the control box behind the control panel. There are six (6) plates that can be set into two set positions to get six different voltages. Unless specified differently, the generator comes from the factory in the 240V position.

### 240 Volt Set position

The voltage change-over board 240V set position uses all 6 plates in 6 different connection places. See Figure 20 below.

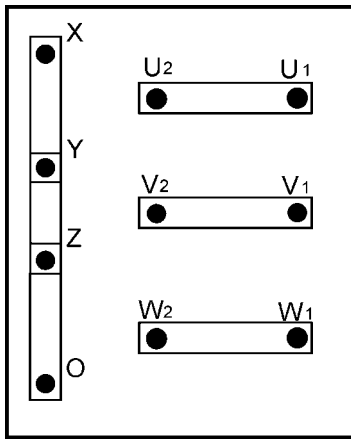


FIGURE 20. Voltage Change-over Board 240V set position.

### 3 Phase, 240 Volt

The following connection, with the voltage change-over board set into the 240V set position (See Figure 20), can offer **THREE PHASE** power at 240V. After hooking up the hard wires to the lugs as shown in figure 20 below, 240V will be the voltage output.

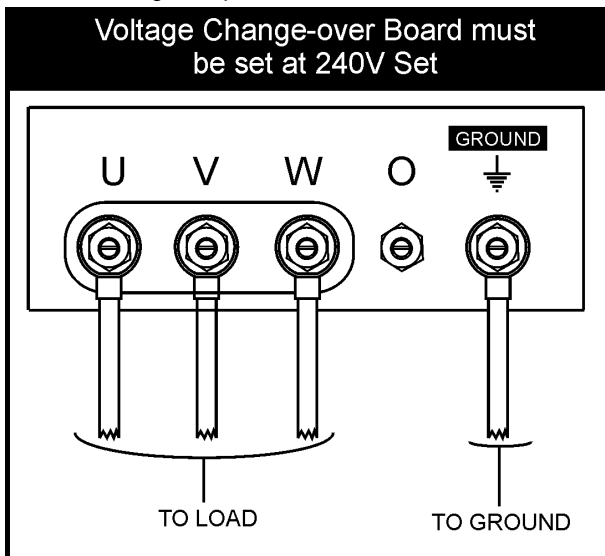


FIGURE 21. Hard Wire Hookup for Three Phase 240V

### Single Phase, 240 Volt

The following connection, with the voltage change-over board set into the 240V set position (See Figure 20), can offer **SINGLE PHASE** power at 240V. After hooking up the hard wires to the lugs as shown in Figure 22 below, 240V will be the voltage output.

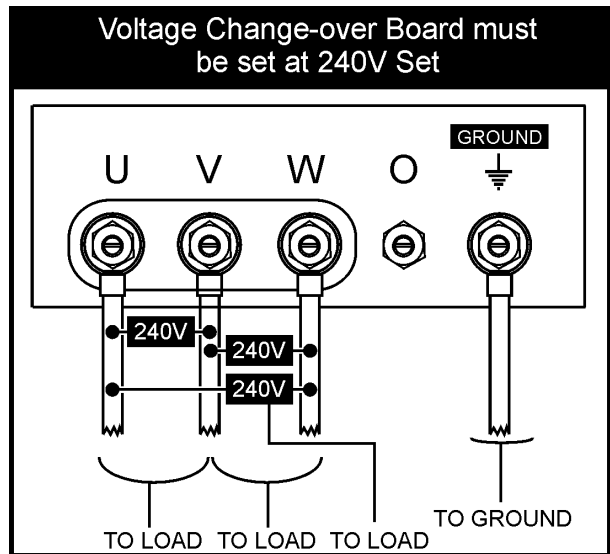


FIGURE 22. Hard Wire Hookup for Single Phase 240V

### Single Phase, 139 Volt

The following connection, with the voltage change-over board set into the 240V set position (See Figure 20), can offer **SINGLE PHASE** power at 139V. After hooking up the hard wires to the lugs as shown in Figure 23 below, 139V will be the voltage output.

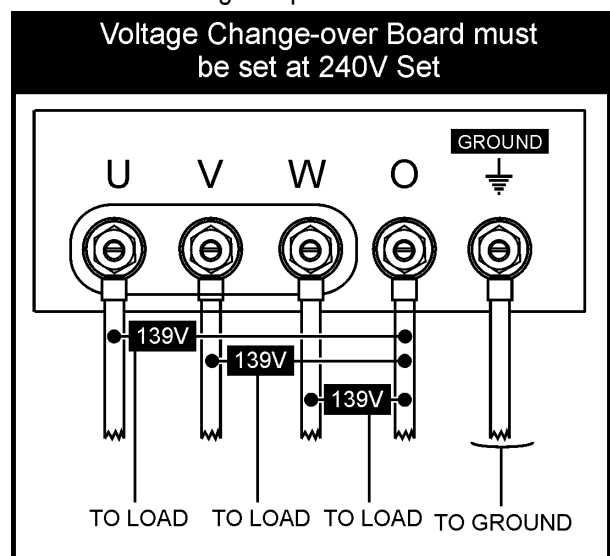


FIGURE 23. Hard Wire Hookup for Single Phase 139V

# DCA-400SSK — OUTPUT TERMINAL PANEL OVERVIEW

## 480 Volt Set position

The voltage change-over board 480V set position uses all 6 plates in 3 different connection places. There are 2 plates at every position (Every plate is used). See Figure 24 below.

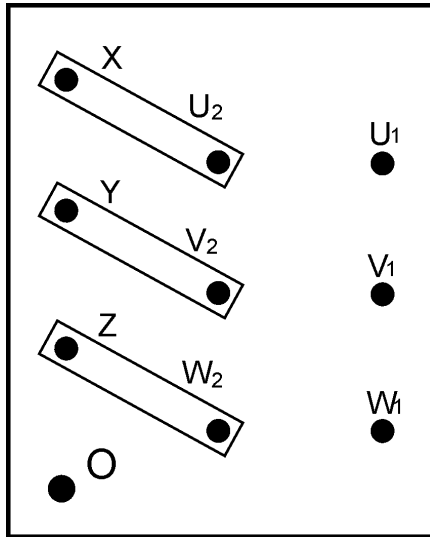


FIGURE 24. Voltage Change-over Board 480V set position.

## 3 Phase, 480 Volt

The following connection, with the voltage change-over board set into the 480V set position (See Figure 24), can offer **THREE PHASE** power at 480V. After hooking up the hard wires to the lugs as shown in Figure 25 below, 480V will be the voltage output.

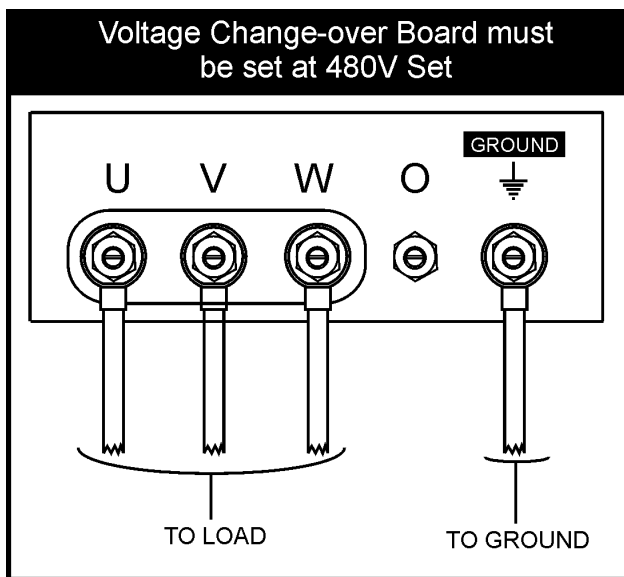


FIGURE 25. Hard Wire Hookup for Three Phase 480V

## Single Phase, 480 Volt

The following connection, with the voltage change-over board set into the 480V set position (See Figure 24), can offer **SINGLE PHASE** power at 480V. After hooking up the hard wires to the lugs as shown in Figure 26 below, 480V will be the voltage output.

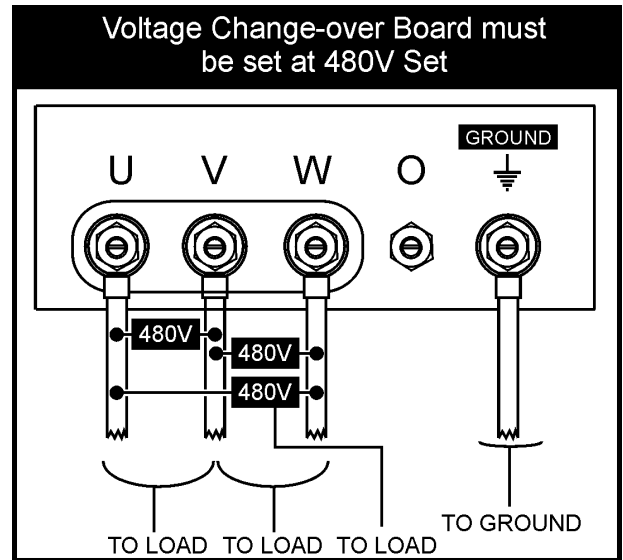


FIGURE 26. Hard Wire Hookup for Single Phase 480V

## Single Phase, 277 Volt

The following connection, with the voltage change-over board set into the 480V set position (See Figure 24), can offer **SINGLE PHASE** power at 277V. After hooking up the hard wires to the lugs as shown in Figure 27 below, 277V will be the voltage output.

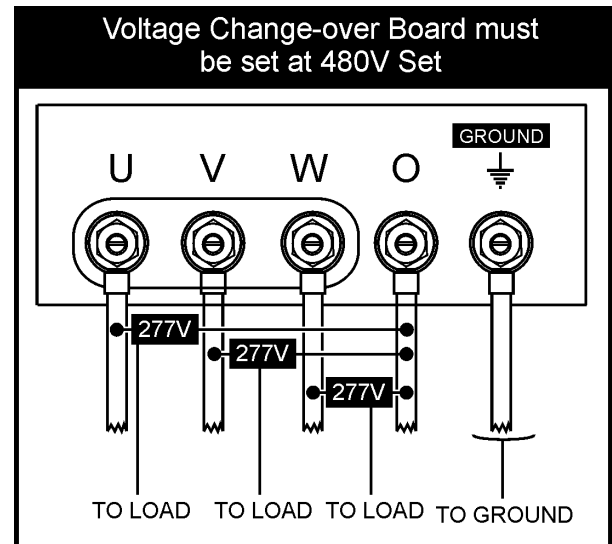


FIGURE 27. Hard Wire Hookup for Single Phase 277V

## Outdoor Installation

Install the generator in a location where it will not be exposed to rain or sunshine. Make sure the generator is on secure level ground so that it cannot slide or shift around. Also install the generator in a manner so that the exhaust will not be discharged in the direction of nearby homes.

The installation site must be relatively free from moisture and dust. All electrical equipment should be protected from excessive moisture. Failure to do will result in deterioration of the insulation and will result in short circuits and grounding.

Foreign materials such as dust, sand, lint and abrasive materials have a tendency to cause excessive wear to engine and alternator parts.

## CAUTION :



Pay close attention to ventilation when operating the generator inside tunnels and caves. The engine exhaust contains noxious elements. Engine exhaust must be routed to a ventilated area.

## Indoor Installation

Exhaust gases from diesel engines are extremely poisonous. Whenever an engine is installed indoors the exhaust fumes must be vented to the outside. The engine should be installed at least two feet from any outside wall. Using an exhaust pipe which is too long or too small can cause excessive back pressure which will cause the engine to heat excessively and possibly burn the valves.

## Mounting

The generator must be mounted on a solid foundation (such as concrete) and set firmly on the foundation to isolate vibration of the generator when it is running. The generator must set at least 6 inches above the floor or grade level (in accordance to NFPA 110, Chapter 5-4.1). DO NOT remove the metal skids on the bottom of the generator. They are to resist damage to the bottom of the generator and to maintain alignment.

## CAUTION :



An electric shock may happen when vibrators are used. Pay close attention to handling when operating vibrators and always use rubber boots and gloves to insulate the body from electrical shock.

## Generator Grounding

To guard against electrical shock and possible damage to the equipment, it is important to provide a good **EARTH** ground.

Article 250 (Grounding) of the National Electrical Code (NEC) provides guide lines for proper grounding and specifies that the cable ground shall be connected to the grounding system of the building as close to the point of cable entry as practical.

NEC articles 250-64(b) and 250-66 set the following grounding requirements:

1. Use one of the following wire types to connect the generator to earth ground.
  - a. Copper - 10 AWG (5.3 mm<sup>2</sup>) or larger.
  - b. Aluminum - 8 AWG (8.4 mm<sup>2</sup>) or larger.
2. When grounding the generator (Figure 28) connect the ground cable between the lock washer and the nut on the generator and tighten the nut fully. Connect the other end of the ground cable to earth ground.
3. NEC article 250-52(c) specifies that the earth ground rod should be buried a minimum of 8 ft. into the ground.

## NOTE

When connecting the generator to any buildings electrical system **ALWAYS** consult with a licensed electrician.

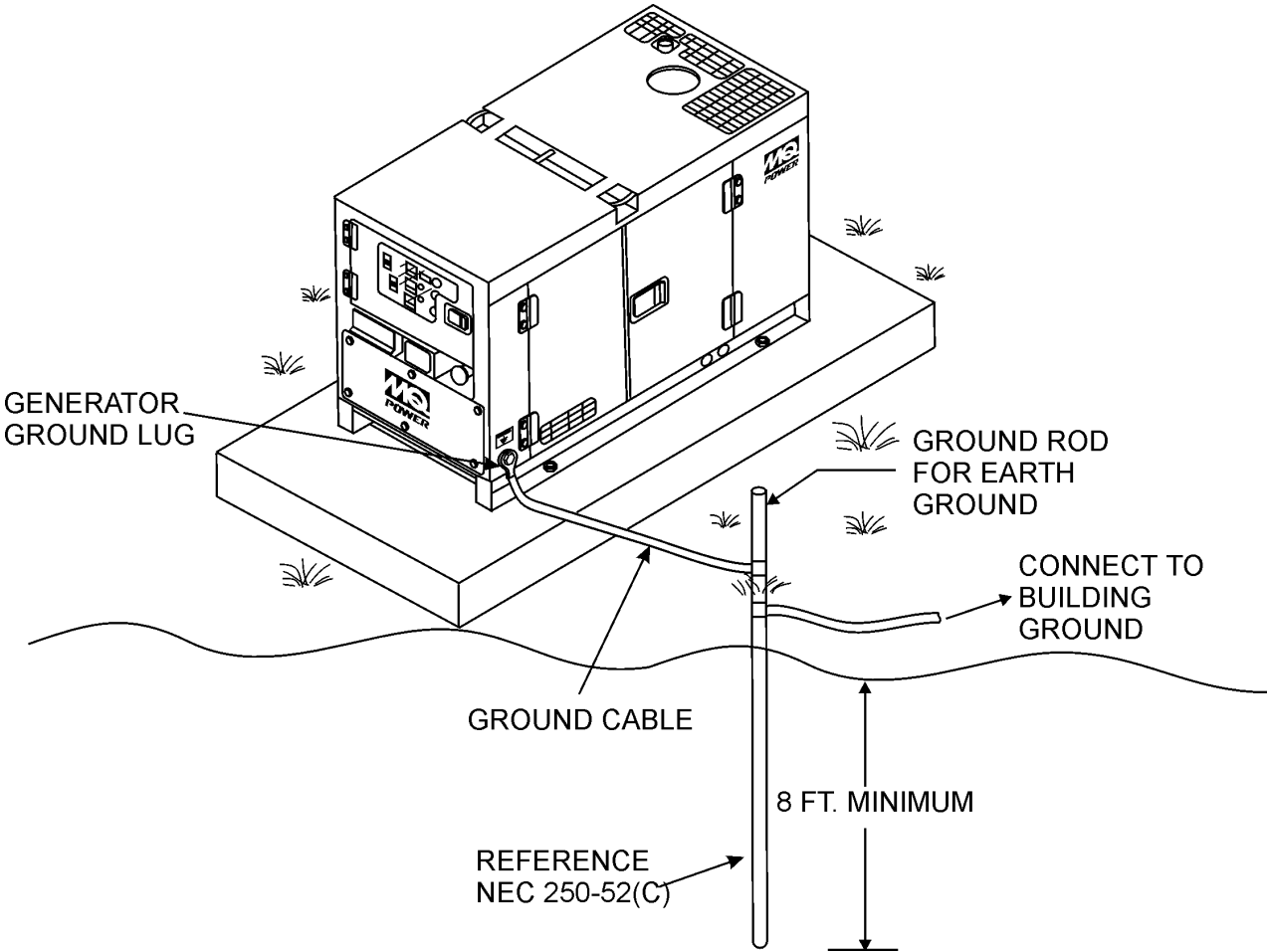


Figure 28. Typical Generator Grounding Application

## General Inspection Prior to Operation

The DCA-400SSK generator has been thoroughly inspected and accepted prior to shipment from the factory. However, be sure to check for damaged parts or components, or loose nuts and bolts, which could have occurred in transit.

## Extension Cable

When electric power is to be provided to various tools or loads at some distance from the generator, extension cords are normally used. Cables should be sized to allow for distance in length and amperage so that the voltage drop between the generator and point of use (load) is held to a minimum. Use the Cable Selection Guide (Table 10) as a guide for selecting proper cable size.

## Circuit Breakers

To protect the generator from an overload, a 3-pole, 1060 amp, **main** circuit breaker is provided to protect the UVW output terminals from overload. In addition two single-pole, 20 amp **GFCI** circuit breakers are provided to protect the GFCI receptacles from overload. Three 50 amp **load** circuit breakers have also been provided to protect the load side of the generator from overload. Make sure to switch **ALL** circuit breakers to the "OFF" position prior to starting the engine.

### NOTE

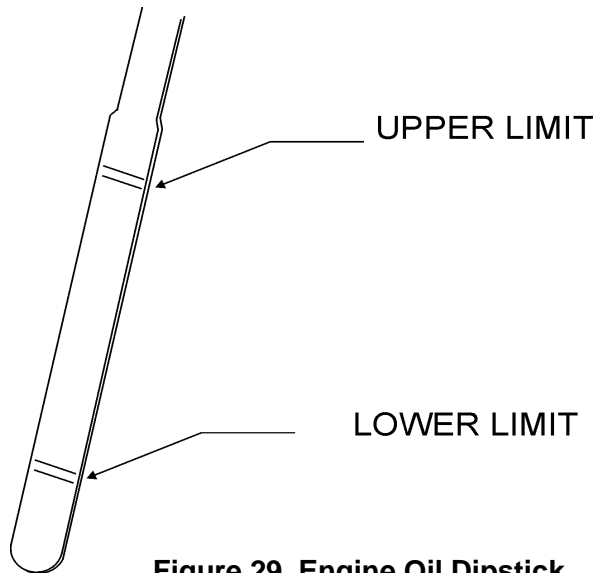
**ALWAYS** consult with a licensed electrician for correct extension cord wire size.

**Table 10. Cable Selection (60 Hz, Single Phase Operation)**

Current in Amperes	Load In Watts		Maximum Allowable Cable Length			
	At 120 Volts	At 240 Volts	#10 Wire	#12 Wire	#14 Wire	#16 Wire
2.5	300	600	1000 ft.	600 ft.	375 ft.	250 ft.
5	600	1200	500 ft.	300 ft.	200 ft.	125 ft.
7.5	900	1800	350 ft.	200 ft.	125 ft.	100 ft.
10	1200	2400	250 ft.	150 ft.	100 ft.	
15	1800	3600	150 ft.	100 ft.	65 ft.	
20	2400	4800	125 ft.	75 ft.	50 ft.	
CAUTION: Equipment damage can result from low voltage.						

## Lubrication Oil

Fill the engine crankcase with lubricating oil through the filler hole, but do not overfill. Make sure the generator is level. With the dipstick inserted all the way, but without being screw into the filler hole, verify that the oil level is maintained between the two notches (Figure 29) on the dipstick. See Table 11 for proper selection of engine oil.



**Figure 29. Engine Oil Dipstick**

When checking the engine oil, be sure to check if the oil is clean and viscous. If the oil is not clean, drain the oil by removing the oil drain plug, and refill with the specified amount of oil as outlined in the **Komatsu Engine Owner's Manual**.

## Fuel

Fill the fuel tank with clean and fresh **diesel fuel**. **DO NOT** fill the tank beyond capacity.

Pay attention to the fuel tank capacity when replenishing fuel. Refer to the fuel tank capacity listed on page 25, Specification Table 7.

The fuel tank cap must be closed tightly after filling. Handle fuel in a safety container. If the container does not have a spout, use a funnel. Wipe up any spilled fuel immediately.

## CAUTION :



Never fill the fuel tank while the engine is running or in the dark. Diesel spillage on a hot engine can cause a fire or explosion. If diesel spillage occurs, wipe up the spilled diesel completely to prevent fire hazards.

## Coolant

Use only drinkable tap water. If hard water or water with many impurities is used, the inside of the engine and radiator may become coated with deposits and cooling efficiency will be reduced.

An anticorrosion additive added to the water will help prevent deposits and corrosion in the cooling system. See the engine manual for further details.

**Table 11. Recommended Motor Oil**

Temperature Range	Type Oil
104° F ~ 23° F (40° C ~ -5°C)	SAE 30
23° F ~ 5° F (-5° C ~ -15°C)	SAE 20 or SAE 10W-30
Below 5° C (-15°)	SAE 10W or SAE 10W-30

## CAUTION :



When adding coolant or antifreeze to the radiator, do not remove the radiator cap until the unit has completely cooled.

Day-to-day addition of coolant is done from the reserve tank. When adding coolant to the radiator, **DO NOT** remove the radiator cap until the unit has completely cooled. See Table 12 for engine, radiator, and reserve tank coolant capacities. Make sure the coolant level in the reserve tank is always between the "H" and the "L" markings.

Table 12. Coolant Capacity

Engine and Radiator	16.9 Gal. (58 Liters)
Reserve Tank	2 Quarts (1.9 Liters)

### Operation in Freezing Weather

When operating in freezing weather, be certain the proper amount of antifreeze (Table 13) has been added.

Table 13. Anti-Freeze Operating Temperatures

Vol % Anti-Freeze	Freezing Point		Boiling Point	
	°C	°F	°C	°F
40	-24	-12	106	222
50	-37	-34	108	226

### NOTE

*When the antifreeze is mixed with water, the antifreeze mixing ratio must be less than 50%.*

### Cleaning the Radiator

The engine may overheat if the radiator fins become overloaded with dust or debris. Periodically clean the radiator fins with compressed air. Cleaning inside the machine is dangerous, so clean only with the engine turned off and the battery disconnected.

### Air Cleaner

Periodic cleaning/replacement is necessary. Inspect it in accordance with the **Komatsu Engine Owner's Manual**.

### Fan Belt Tension

The fan belt deflection may contribute to overheating, or to insufficient charging of the battery. Inspect the fan belt for damage and wear and adjust it in accordance with the **Komatsu Engine Owner's Manual**.

The fan belt tension is proper if the fan belt deflects 7 to 10 mm (Figure 30) when depressed with the thumb as shown below.

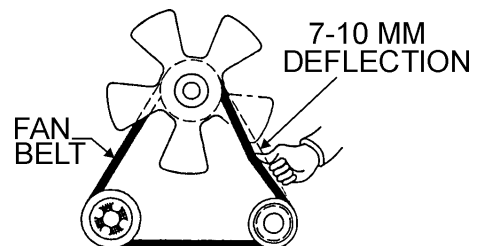


Figure 30. Fan Belt Tension

## CAUTION :



Never place hands near the belts or fan while the generator set is running.

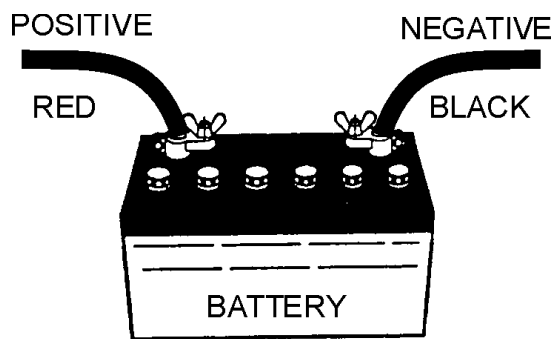
### Battery

**DO NOT** reverse the connections of the battery. The battery is sufficiently charged if the specific gravity of the battery fluid is 1.28 (at 68°F). If the specific gravity should fall to 1.245 or lower, it indicates the battery is discharged and needs to be recharged or replaced.

Check to see whether the battery cables are loose. Poor contact may result in poor starting or malfunctions. Always keep the terminals firmly tightened.

## Battery Cable Installation

**ALWAYS** be sure that the battery cables (Figure 31) are properly connected to the battery terminals as shown below. The **RED** cable is connected to the positive terminal of the battery, and the **BLACK** cable is connected to the negative terminal of the battery.



**Figure 31. Battery Connections**

## CAUTION :



Inadequate battery connections may cause poor starting of the generator, and create other malfunctions.

### Wiring

Inspect the entire generator for bad or worn electrical wiring or connections. If any wiring or connections are exposed (insulation missing) replace wiring immediately.

### Piping and Hose Connection

Inspect all piping, oil hose, and fuel hose connections for wear and tightness. Tighten all hose clamps and check hoses for leaks.

If any hose (fuel or oil) lines are defective replace them immediately.

## CAUTION :



If the battery cable is connected incorrectly, electrical damage to the generator will occur. Pay close attention to the polarity of the battery when connecting the battery.

When connecting battery do the following:

1. **DO NOT** connect the battery cables to the battery terminals when the **Off/Manual/Auto** switch is in either the manual or auto position (ON). **ALWAYS** make sure that the Off/Manual/Auto switch is in the OFF position when connecting the battery.
2. Place a small amount of grease around both battery terminals. This will ensure a good connection and will help prevent corrosion around the battery terminals.

## Single Phase Load

Always be sure to check the nameplate on the generator and equipment to insure the wattage, amperage and frequency requirements are satisfactorily supplied by the generator for operating the equipment.

Generally, the wattage listed on the nameplate of the equipment is its rated output. Equipment may require 130—150% more wattage than the rating on the nameplate, as the wattage is influenced by the efficiency, power factor and starting system of the equipment.

### NOTE

If wattage is not given on the equipment's name plate, approximate wattage may be determined by multiplying nameplate voltage by the nameplate amperage.

$$\text{WATTS} = \text{VOLTAGE} \times \text{AMPERAGE}$$

The power factor of this generator is 1.0. See Table 14. below when connecting loads.

**Table 14. Power Factor By Load**

Type Of Load	Power Factor
Single-phase induction motors	0.4 - 0.75
Electric heaters, incandescent lamps	1.0
Fluorescent lamps, mercury lamps	0.4 - 0.9
Electronic devices, communication equipment	1.0

## Three Phase Load

When calculating the power requirements for 3-phase power use the following equation:

$$\text{KVA} = \frac{\text{VOLTAGE} \times \text{AMPERAGE} \times \sqrt{3}}{1000}$$

## CAUTION:



Motors and motor-driven equipment draw much greater current for starting than during operation.

An inadequate size connecting cable which cannot carry the required load can cause a voltage drop which can burn out the appliance or tool and overheat the cable.

- When connecting a resistance load such as an incandescent lamp or electric heater, a capacity of up to the generating set's rated output (kW) can be used.
- When connecting a fluorescent or mercury lamp, a capacity of up to the generating set's rated output (kW) multiplied by 0.6 can be used.
- When connecting an electric drill or other power tools, pay close attention to the required starting current capacity.

When connecting ordinary power tools, a capacity of up to the generating set's rated output (kW) multiplied by 0.8 can be used.

## CAUTION:



Before connecting this generator to any building's electrical system, a licensed electrician must install an isolation (transfer) switch. Serious injury or death may result without this transfer switch.

### NOTE

If output (kVA) is not given on the equipment nameplate, approximate output may be determined by multiplying voltage by amperage by  $\sqrt{3}$ .

# DCA-400SSK — GENERATOR START-UP PROCEDURE (MANUAL)

## WARNING:



The engine's exhaust contains harmful emissions. **ALWAYS** ventilate the exhaust when operating inside tunnels, excavations or buildings. Direct exhaust away from nearby personnel.

### Before Starting Engine

1. Check the lubricating oil level prior to starting the engine. Make sure the generator is level. The oil level must be maintained between two notches on the dipstick.
2. When there is not enough lubricating oil, fill the crankcase with high grade motor oil. Use a high quality detergent oil classified CC or higher (See Table 11 on page 45).
3. Check the coolant level in the radiator and subtank. Replenish with antifreeze as necessary. Always maintain the coolant level between the **FULL** and **LOW** markings on the coolant container. Be sure the radiator cap is fastened securely.
4. Check the fuel level on the fuel gauge. If fuel is low, fill the fuel tank with clean fresh unleaded automotive diesel. If diesel spillage occurs, completely wipe up the spilled fuel immediately.

### Before Starting

#### Generator and Control Panel

## CAUTION:



**NEVER** start the engine with the **main**, **GFCI** or **load** circuit breakers in the **ON** position.

1. Be sure to disconnect the electrical load and switch the **main**, **load** and **G.F.C.I.** circuit breakers (Figure 32) to the "OFF" position prior to starting the engine.

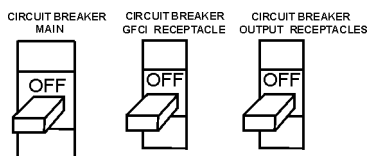


Figure 32. Main, GFCI and Load Circuit Breakers

### Jacket Water Heater and Internal Battery Charger 120 VAC Output Receptacles

This generator is equipped with two 120 VAC, 20 amp output receptacles located on the output terminal panel, page 36, Figure 14.

The purpose of these receptacles is to provide power via commercial power to the jacket water heater and internal battery charger.

Remember that these receptacles will **ONLY** function when commercial power has been supplied to them (Figure 15). To apply commercial power to these receptacles, a power cord of adequate size will be required.

When using the generator in **hot** climates there is no reason to apply power to jacket water heater. However, if the generator will be used in **cold** climates it is always a good idea to apply power to the jacket water heater at all times. To apply power to the jacket water heater, apply power to the jacket water heater receptacle via commercial power using an power cord of adequate size.

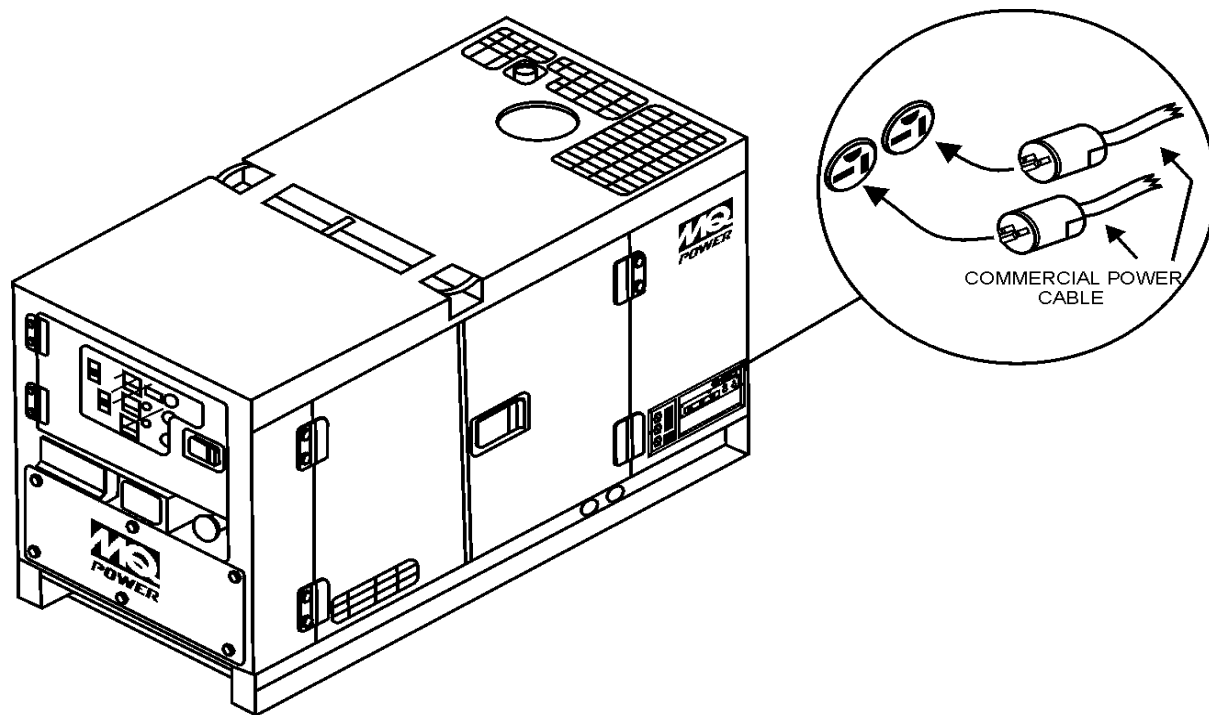
If the generator will be used daily, the battery should normally not require charging. If the generator will be idle (not used) for long periods of time, apply power to the battery charger receptacle via commercial power using an power cord of adequate size.

When connecting the generator to a isolation (transfer) switch, **ALWAYS** have power applied to the generator's internal battery charger. This will ensure that the engine will not fail due to a dead battery.

## CAUTION:

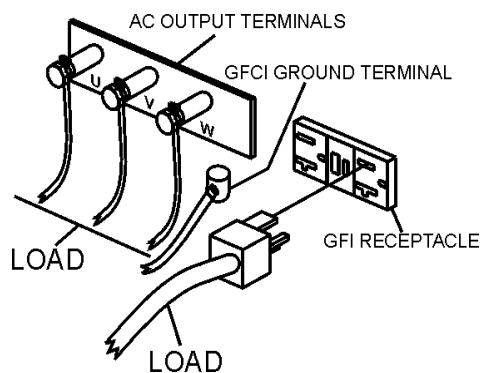


**ALWAYS** have power applied to the generator's internal battery charger when connecting the generator to a isolation (transfer) switch. Before connecting this generator to any buildings electrical system, have a **licensed** electrician perform the installation of the transfer switch.

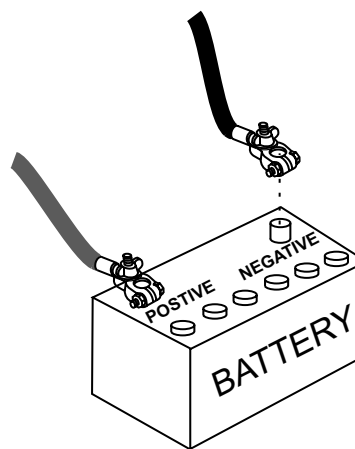


**Figure 33. 120 VAC Accessory Receptacle/Cable**

2. Once it is determined if commercial power is required, connect the load to the UVW terminals as shown in Figure 34. These terminals can be found on the output terminal panel, see page 36, Figure 14. To gain access to the output terminals lift the UVW cover. Make sure to tighten terminal nuts securely to prevent load wires from slipping out.
3. Connect the negative battery cable (BLACK) to the negative post on the battery (Figure 35).



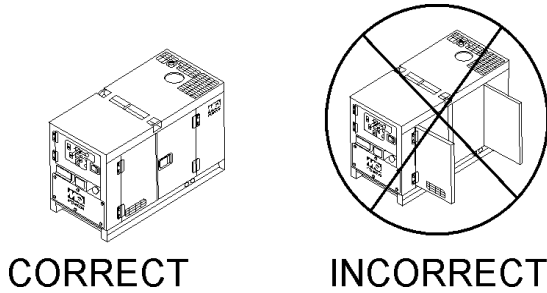
**Figure 34. UVW Terminal Lugs (Load)**



**Figure 35. Battery Connections**

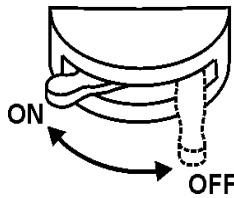
# DCA-400SSK — GENERATOR START-UP PROCEDURE (MANUAL)

4. Close all engine enclosure doors (Figure 36).



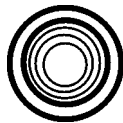
**Figure 36. Engine Enclosure Doors**

5. Set the battery ON/OFF switch (Figure 37) to the ON position.



**Figure 37. Battery ON/OFF Switch**

6. When starting the generator in **COLD** weather conditions, press and hold the engine preheat button (Figure 38) until the preheat lamp (Figure 39) is lit (ON).

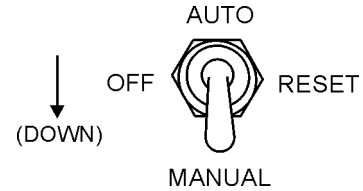


**Figure 38. Engine Pre-Heat Button**



**Figure 39. Engine Pre-Heat Lamp**

7. Place the Off/Manual/Auto switch (Figure 40) in the **MANUAL** position (down). Observe that the engine begins to crank.



**Figure 40. Off/Manual/Auto Switch (Manual)**

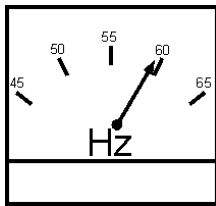
8. After engine starts, verify that the "Engine Running" status LED (Figure 41) on the Microprocessor Engine Control Module (MPEC) display is "ON" (lit).



**Figure 41. MPEC Engine Running Status LED**

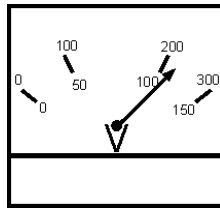
# DCA-400SSK — GENERATOR START-UP PROCEDURE (MANUAL)

9. The generator's frequency meter (Figure 42) displays the 60 cycle output frequency in **HERTZ**.

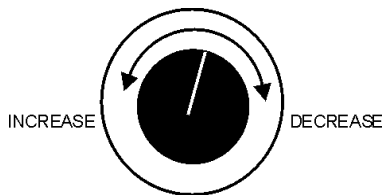


**Figure 42. Frequency Meter (Hz)**

10. The generator's voltage meter (Figure 43) displays the 120 VAC in **VOLTS**. If the voltage is not within the specified frequency tolerance, use the voltage adjustment control knob (Figure 44) to increase or decrease the desired voltage.

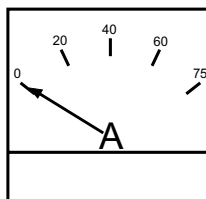


**Figure 43. Voltage Meter (Volts)**



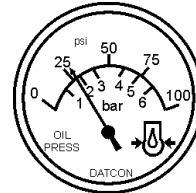
**Figure 44. Voltage Adjust Control Knob**

11. The ammeter (Figure 45) will indicate zero amps with no load applied. When a load is applied, this meter will indicate the amount of current that the load is drawing from the generator's alternator.



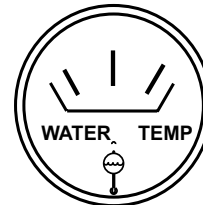
**Figure 45. Ammeter (No Load)**

12. The engine oil pressure gauge (Figure 46) will indicate the oil pressure (kg/ cm<sup>2</sup>) of the engine. Under normal operating conditions the oil pressure should be approximately 25 psi.



**Figure 46. Oil Pressure Gauge**

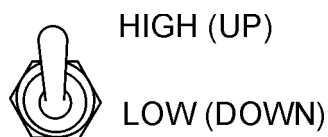
13. The coolant temperature gauge (Figure 47) will indicate the coolant temperature. Under normal operating conditions the coolant temperature should be between 165 and 215 degrees Fahrenheit (Green Zone).



**Figure 47. Coolant Temperature Gauge**

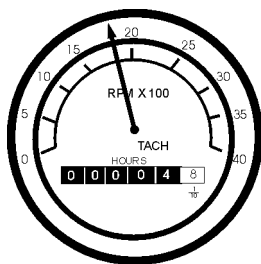
# DCA-400SSK — GENERATOR START-UP PROCEDURE (MANUAL)

14. Set the engine speed switch (Figure 48) to low to idle engine, set to high when a load is being applied.



**Figure 48. Engine Speed Switch**

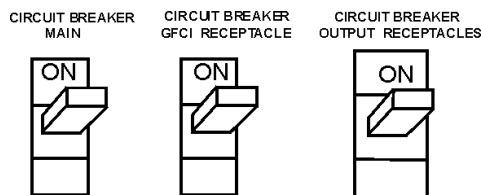
15. The tachometer (Figure 49) will indicate the speed of the engine when the generator is operating. Under normal operating conditions this speed should be approximately 1800 RPM's.



**Figure 49. Engine Tachometer**

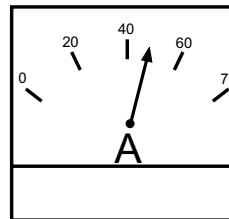
16. After the engine has been running for a few minutes, look at the status LED'S on the "MPEC" display (Figure 41) and check it for any abnormal conditions. If any abnormal conditions exist, shut down the engine and take corrective action to solve the problem.

17. If there are no abnormal problems shown on the "MPEC" LED display, turn the MAIN, GFCI and LOAD circuit breakers to their ON position (Figure 50).



**Figure 50. Main and GFCI Circuit Breakers**

18. Look at the generator's ammeter (Figure 51) and verify that it reads the anticipated amount of current with respect to the load. Remember the ammeter will only display a current reading if the load is in use.



**Figure 51. Ammeter (Load)**

19. The generator will run until manually stopped or an abnormal condition occurs.

# DCA-400SSK — GENERATOR START-UP PROCEDURE (AUTO)

## CAUTION:



Before connecting this generator to any building's electrical system, a **licensed electrician** must install an isolation (transfer) switch. Serious *injury* or *death* may result without this transfer switch.

## CAUTION:



When connecting the generator to a isolation (transfer) switch, **ALWAYS** have power applied to the generator's internal battery charger. This will ensure that the engine will not fail due to a dead battery.

Starting the generator in the "**AUTO**" mode is similar to starting the generator in the "**MANUAL**" mode, with a few exceptions.

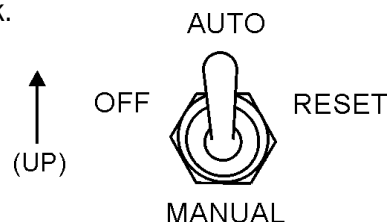
## CAUTION:



When running the generator in the **AUTO** mode, remember the generator can start up at any time without warning. **NEVER** attempt to perform any maintenance when the generator is in the auto mode.

When starting generator in Auto mode use the "Manual Start-up" procedure except where noted (see below).

1. Perform steps 1 through 6 (Before Starting, pages 49-52) as outlined in the manual starting procedure.
2. Apply commercial power to the internal battery charger receptacle (to ensure good starting) via commercial power. An external power cord will be required.
3. Apply commercial power to the jacket water heater receptacle (not necessary for warm climates) via commercial power. An external power cord will be required.
4. Place the Off/Manual/Auto switch (Figure 52) in the **AUTO** position (up). Observe that the engine begins to crank.



**Figure 52. Off/Manual Auto Switch (AUTO)**

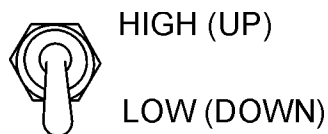
5. Continue to follow the steps outline in the manual start-up procedure (start at step 9, page 52).

# DCA-400SSK — GENERATOR SHUTDOWN PROCEDURE

## Engine Shutdown

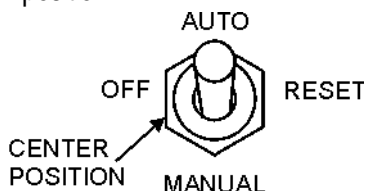
To shutdown the generator use the following procedure:

1. Place both the **MAIN**, **GFCI** and **LOAD** circuit breakers to the "OFF position"
2. Set the engine speed switch (Figure 53) to the idle (low) position.



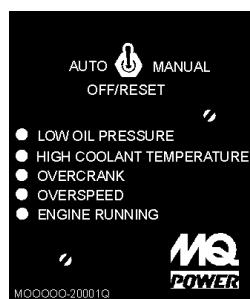
**Figure 53. Engine Speed Switch**

3. Let the engine cool by running it for 3-5 minutes with no load applied.
4. Place the Off/Manual/Auto Switch (Figure 54) in the "OFF/RESET" position



**Figure 54. Off/Manual Auto Switch (OFF)**

5. Verify that the "Engine Running" status LED (Figure 55) on the Microprocessor Engine Control Module (MPEC) display is "OFF" (not lit).



**Figure 55. MPEC Engine Running Status LED (OFF)**

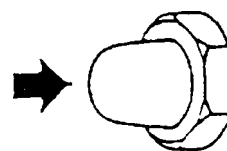
6. Remove the load from the UVW terminal strip (Figure 15).

## Emergency Stop



**NEVER** stop the engine suddenly except in an emergency. **DO NOT** use the emergency stop switch as a method of shutting down the engine. This switch is **ONLY** to be used in the event of an emergency.

1. To stop the engine in the event of an emergency, **PUSH** the emergency stop button (Figure 56) inward.



**Figure 56. Emergency Stop Button**

## General Inspection

Prior to each use, the generating set should be cleaned and inspected for deficiencies. Check for loose, missing or damaged nuts, bolts or other fasteners. Also check for fuel or oil leaks.

**Engine Side, Fuel, Oil and Coolant** (Refer to the Engine Instruction Manual)

## Air Cleaner

Every 50 hours: Remove air cleaner element and clean heavy duty paper element with kerosene, or foam element with liquid detergent and hot water. Wrap foam element in a cloth and squeeze dry. For heavy duty paper element, wipe excess kerosene with towel.

## Fuel Addition

Add diesel fuel (the grade may vary according to season and locations). Always pour through the mesh filter.

## Removing Water from the Tank

After prolonged use, water and other impurities accumulate in the bottom of the tank. Occasionally remove the drain cock and drain the contents. During cold weather, the greater the empty volume inside the tank, the easier it is for water to condense. This can be reduced by always keeping the tank as full as possible.

## Air Removal

If air enters the fuel injection system of a diesel engine, starting becomes impossible. After running out of fuel, or after disassembling the fuel system, bleed the system according to the following procedure.

To restart after running out of fuel, turn the key switch to the "START" position for 15-30 seconds. Try again, if needed. This unit is equipped with an automatic air bleeding system.

## Service Daily

If engine is operating in very dusty and dry grass conditions, a clogged air cleaner will result in high fuel consumption, loss of power and excessive carbon buildup in the combustion chamber.

## Cleaning the Fuel Strainer

Clean the fuel strainer if it contains dust or water. Remove dust or water in the strainer cap and wash it in diesel. Securely fasten the fuel strainer cap so that fuel will not leak. Check the fuel strainer every 200 hours of operation or once a month.

## Check Oil Level

Check the crankcase oil level prior to each use, or when the fuel tank is filled. Insufficient oil may cause severe damage to the engine. Make sure the generator is level. The oil level must be between the two notches on the dipstick as shown in Figure 29, page 45.

## Generator Storage

For storage of the generator for over 30 days, the following is required:

- Drain the fuel tank completely.
- Completely drain the oil from the crankcase and refill with fresh oil.
- Clean all external parts of the generator with a cloth.
- Cover the generating set and store in a clean, dry place.

## Water Separator Filter

Replace the water separator filter (Figure 58) every 500 hours if two filters are being used. If one filter is being used, replace every 250 hours.

The filters should also be replaced if the vacuum gauge indicates between 6 to 10 inches of mercury (in. Hg.)

6-10 In. Hg.  
REPLACE WATER  
SEPARATOR FILTER  
IF GAUGE READS  
IN THIS RANGE

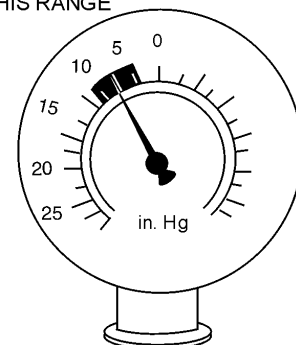


Figure 58. Water Separator Filter Gauge

To replace the **water separator filter** element perform the following:

1. Remove the lid from the filter housing. Remove the element by holding the module handle and slowly pulling upward with a twisting motion.
2. Replace the lid gasket with the one supplied with the new filter element. Apply a coating of clean fuel or motor oil to seal prior to reassembly. Insert the new filter element with a slow downward twisting motion.
3. Fill the unit with clean fuel, then set the lid back on top of the filter housing, and tighten snugly using the T-bar handle.
4. Start the engine and check for any leaks. If any leaks occur with the engine running, turn the engine off and fix the leak.

INSPECTION / MAINTENANCE		10 Hrs DAILY	250 Hrs	500 Hrs	1000 Hrs
ENGINE	Check Engine Fluid Levels	X			
	Check Air Cleaner	X			
	Check Battery Acid Level	X			
	Check Fan Belt Condition	X			
	Check for Leaks	X			
	Check for Loosening of Parts	X			
	Check Water Separator	X			
	Check Blow-by Oil Mist Tank	X			
	Replace Engine Oil and Filter *1		X		
	Clean Air Filter		X		
	Drain Bottom of Fuel Tank		X		
	Clean Unit, Inside and Outside		X		
	Change Fuel Filter *2			X	
	Replace Water Separator Element *3		(X)	X	
	Clean RAdiator and Check Coolant Protection Level			X	
	Replace Air Filter Element				X
	Change Corrosion Resistor				X
	Check all Hoses and Clamps				X
Clean Inside of Fuel Tank				X	
GENERATOR	Measure Insulation Resistance Over 3M ohms		X		

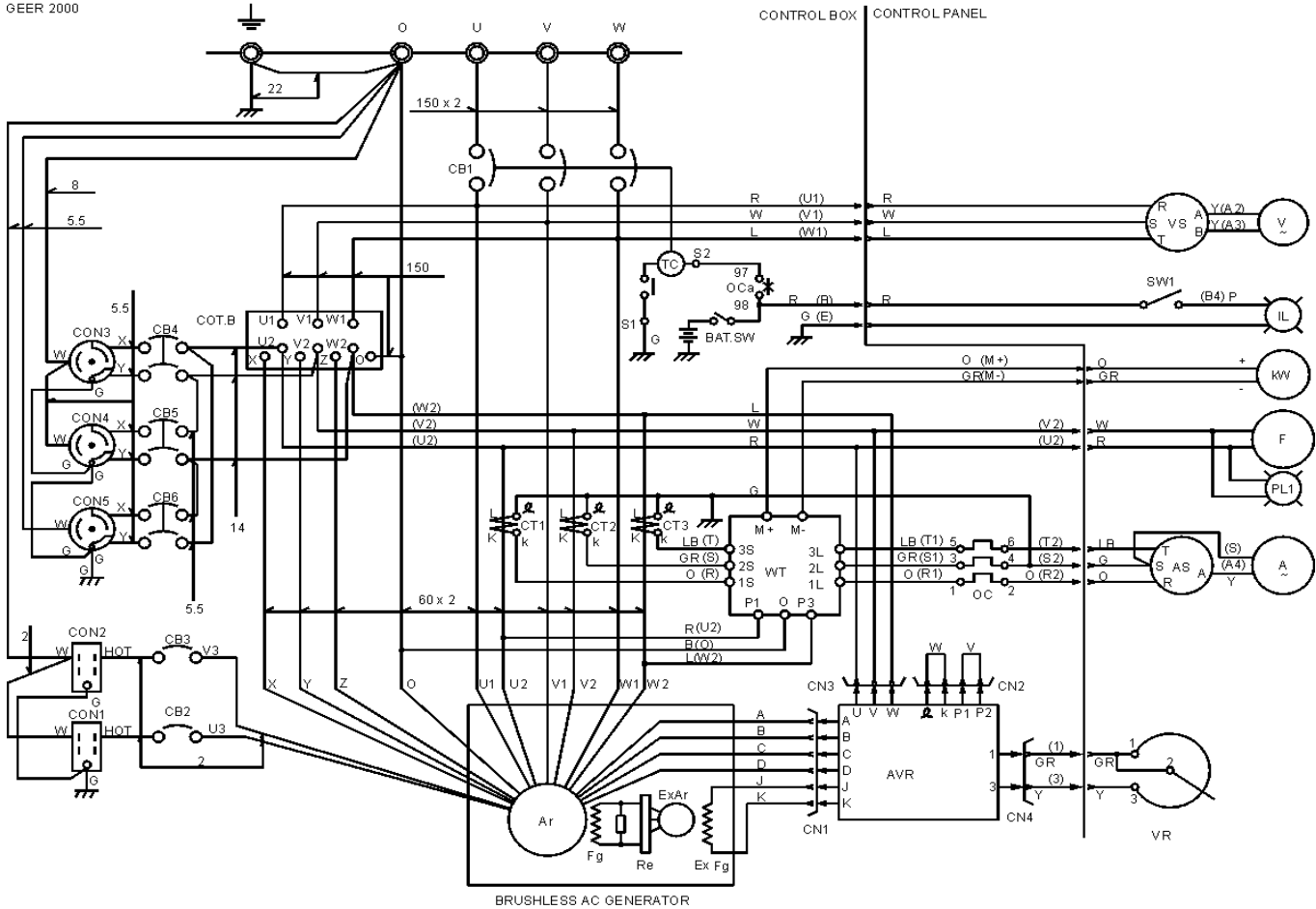
\*1 Replace engine oil and filter at 100 hours, first time only.

\*2 Replace fuel filter at 250 Hours, first time only.

\*3 Refer to the item "Water Separator Filter".

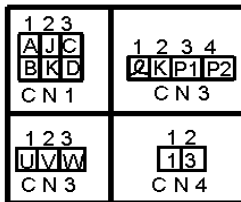
# DCA-400SSK — GENERATOR WIRING DIAGRAM

DCA400SSK GENERATOR WIRE DIAGRAM  
GEER 2000

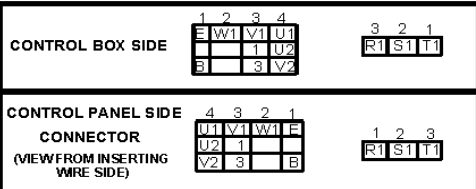


BRUSHLESS AC GENERATOR

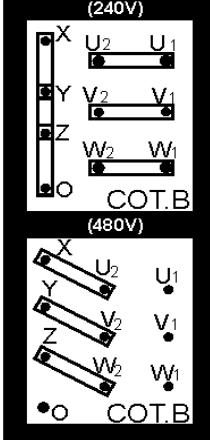
## AVR CONNECTOR



(VIEW FROM INSERTING WIRE SIDE)



## SETTING FOR OUTPUT VOLTAGE



MARK	NAME
Ar	MAIN GENERATOR ARMATURE WINDING
Fg	MAIN GENERATOR FIELD WINDING
ExAr	EXCITER ARMATURE WINDING
ExFg	EXCITER FIELD WINDING
AVR	AUTOMATIC VOLTAGE REGULATOR
VR	VOLTAGE REGULATING RHEOSTAT
Re	RECTIFIER
CT1-3	CURRENT TRANSFORMER (750/5A)
C B 1	CIRCUIT BREAKER (1000A)
OC	OVER CURRENT RELAY
COT. B	VOLTAGE CHANGE-OVER BOARD
AS	AMMETER CHANGE-OVER SWITCH
A	AC AMMETER (0~750, 1500A)
VS	VOLTMETER CHANGE-OVER SWITCH
V	AC VOLTMETER (0~600)
F	FREQUENCY METER (45~65HZ)
PI1	PILOT LAMP
CB2, 3	AUX. CIRCUIT BREAKER (20A)
CB4-6	AUX. CIRCUIT BREAKER (50A)
CON1, 2	AUX POWER RECEPTACLE (20A)
CON3-5	AUX POWER RECEPTACLE (50A)
IL	PANEL LIGHT
SW1	PANEL LIGHT SWITCH
kW	WATTMETER -40 ~ +400 kW
WT	WATTMETER TRANSDUCER

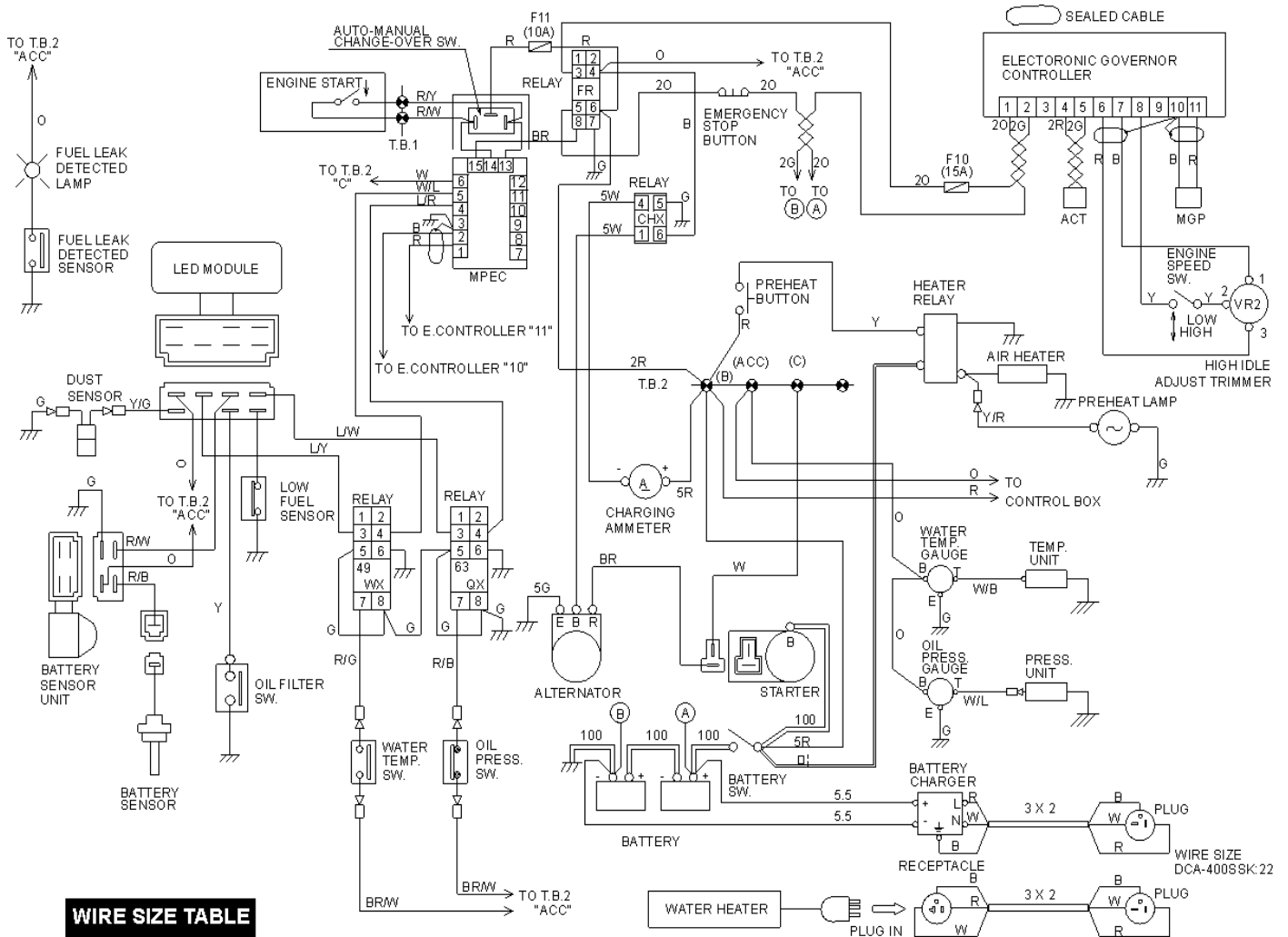
## WIRE SIZE TABLE

150: 150 mm <sup>2</sup>
60: 60 mm <sup>2</sup>
22: 22 mm <sup>2</sup>
14: 14 mm <sup>2</sup>
8: 8 mm <sup>2</sup>
2: 2 mm <sup>2</sup>
NO MARK: 2 mm <sup>2</sup>

## COLOR CODE TABLE

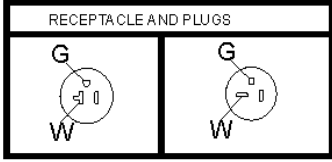
CODE/WIRE COLOR			
B	BLACK	R	RED
L	BLUE	W	WHITE
BR	BROWN	Y	YELLOW
G	GREEN	LB	LIGHT BLUE
GR	GRAY	LG	LIGHT GREEN
V	VIOLET	O	ORANGE
P	PINK		

# DCA-400SSK — ENGINE WIRING DIAGRAM

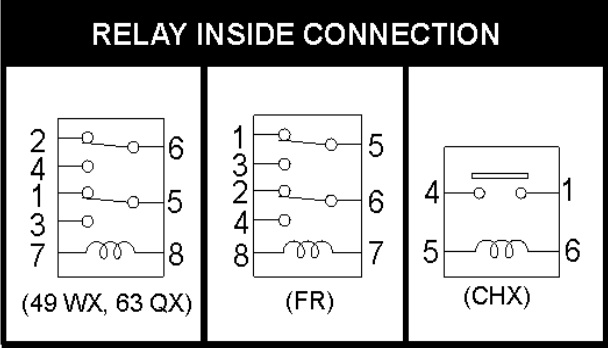


## WIRE SIZE TABLE

100:	100mm <sup>2</sup>
38:	38mm <sup>2</sup>
22:	22mm <sup>2</sup>
14:	14mm <sup>2</sup>
5 :	5mm <sup>2</sup>
2 :	2mm <sup>2</sup>
NO MARK:	2 mm <sup>2</sup>



COLOR CODE TABLE			
CODE/ WIRE COLOR			
B	BLACK	R	RED
L	BLUE	W	WHITE
BR	BROWN	Y	YELLOW
G	GREEN	LB	LIGHT BLUE
GR	GRAY	LG	LIGHT GREEN
V	VIOLET	O	ORANGE
P	PINK		



# DCA-400SSK — TROUBLESHOOTING (ENGINE)

Practically all breakdowns can be prevented by proper handling and maintenance inspections, but in the event of a breakdown, please take a remedial action following the diagnosis based on the Engine Troubleshooting (Table 15) and MPEC Troubleshooting (Table 16) information shown below and on the preceding page. If the problem cannot be remedied, consult our company's business office or service plant.

## TABLE 15. ENGINE TROUBLESHOOTING

SYMPTOM	POSSIBLE PROBLEM	SOLUTION
Engine does not start.	No fuel?	Replenish fuel.
	Air in the fuel system?	Bleed system.
	Water in the fuel system?	Remove water from fuel tank.
	Fuel pipe clogged?	Clean fuel pipe.
	Fuel filter clogged?	Clean or change fuel filter.
	Excessively high viscosity of fuel or engine oil at low temperature?	Use the specified fuel or engine oil.
	Fuel with low cetane number?	Use the specified fuel.
	Fuel leak due to loose injection pipe retaining nut?	Tighten nut.
	Incorrect injection timing?	Adjust.
	Fuel cam shaft worn?	Replace.
	Injection nozzle clogged?	Clean injection nozzle.
	Injection pump malfunctioning?	Repair or replace.
	Seizure of crankshaft, camshaft, piston, cylinder liner or bearing?	Repair or replace.
	Compression leak from cylinder?	Replace head gasket, tighten cylinder head bolt, glow plug and nozzle holder.
	Improper valve timing?	Correct or replace timing gear.
	Piston ring and liner worn?	Replace.
Excessive valve clearance?	Adjust.	
Starter does not run.	Battery discharged?	Charge battery.
	Starter malfunctioning?	Repair or replace.
	Key switch malfunctioning?	Repair or replace.
	Wiring disconnected?	Connect wiring.

# DCA-400SSK — TROUBLESHOOTING (ENGINE)

## TABLE 15. ENGINE TROUBLESHOOTING (CONTINUED)

SYMPTOM	POSSIBLE PROBLEM	SOLUTION
Engine revolution is not smooth.	Fuel filter clogged or dirty?	Clean or change.
	Air cleaner clogged?	Clean or change.
	Fuel leak due to loose injection pipe retaining nut?	Tighten nut.
	Injection pump malfunctioning?	Repair or replace.
	Incorrect nozzle opening pressure?	Adjust.
	Injection nozzle stuck or clogged?	Repair or replace.
	Fuel over flow pipe clogged?	Clean.
	Governor malfunctioning?	Repair.
Either white or blue exhaust gas is observed.	Excessive engine oil?	Reduce to the specified level.
	Piston ring and liner worn or stuck?	Repair or replace.
	Incorrect injection timing?	Adjust.
	Deficient compression?	Adjust top clearance.
Either black or dark gray exhaust gas is observed.	Overload?	Lessen the load.
	Low grade fuel used?	Use the specified fuel.
	Fuel filter clogged?	Clean or change.
	Air cleaner clogged?	Clean or change.
	Deficient nozzle injection?	Repair or replace the nozzle.
Deficient output.	Incorrect injection timing?	Adjust.
	Engine's moving parts seem to be seizing?	Repair or replace.
	Uneven fuel injection?	Repair or replace the injection pump.
	Deficient nozzle injection?	Repair or replace the nozzle.
	Compression leak?	Replace head gasket, tighten cylinder head bolt, glow plug and nozzle holder.

# DCA-400SSK — TROUBLESHOOTING (ENGINE)

**TABLE 15. ENGINE TROUBLESHOOTING (CONT)**

SYMPTOM	POSSIBLE PROBLEM	SOLUTION
Engine fails to start and starter does not rotated.	Dead battery?	Replace battery.
	Defective starter switch?	Replace switch.
	Fuse burned out?	Replace fuse.
Engine fails to start and starter rotates.	Broken pre-heat circuit?	Check pre-heat circuit.
	No fuel?	Add fuel.
	Defective wiring?	Check wiring.
Engine starts and remains at low speed.	Clogged fuel strainer?	Clean or replace.
	Clogged air cleaner?	Clean or replace.
	Disconnected wiring?	Check and repair wiring.
Engine speed rises and no voltage is present in AC power source.	No voltage present in AC power source?	Replace rectifier (RE1).
	Defective rotor?	Replace rotor.
	Defective voltmeter?	Replace voltmeter.
	Disconnected wiring?	Check and repair wiring.
	Layer short-circuit in armature winding?	Replace armature.
Engine speed rises and AC power voltage is too low or cannot be used.	Defective circuit breaker (protector)?	Replace circuit breaker (protector).
	Layer short-circuit, broken wires in armature winding?	Repair or replace armature.
Engine speed rises and battery discharges too soon.	Defective engine regulator?	Replace regulator.
	Defective wiring?	Repair or replace wiring.
Engine speed rises and engine seems overloaded.	Defective alternator?	Repair or replace alternator.
	Damaged alternator bearing?	Replace alternator bearings.

## TABLE 16. MPEC TROUBLESHOOTING

Sympton	Possible Cause	Solution
Low oil pressure light is on.	Low oil level?	Fill oil level.
	Oil pressure sending unit failure?	Replace oil pressure sending unit.
	Time delay malfunction in MPEC?	Refer to dealer.
	Wire shorted?	Inspect/repair wire.
Low coolant level light is on.	Low coolant level?	Fill coolant level.
	Sending unit failure?	Replace sending unit.
	Low battery voltage?	Replace/charge battery.
High coolant temperature light is on.	Fan belt tension incorrect?	Tighten/replace fan belt.
	Air flow is not circulation through radiator?	Clean/repair radiator grill.
	Doors open?	Close doors.
	Exhaust leaking?	Replace/repair gaskets or faulty part.
	Generator being overloaded?	Check/reduce load.
	Thermostat failure?	Replace thermostat.
	Air intake blocked?	Clear all air intakes.
	Temperature switch failure?	Replace temperature switch.
Overcrank light is on.	No or low Fuel?	Fill fuel level.
	MPEC needs to be calibrated?	Refer to dealer.
Overspeed light is on.	RPM engine speed too high?	Adjust RPM.
	Governor actuator needs to be adjusted?	Adjust governor actuator.
	Governor controller needs to be adjusted?	Adjust governor controller.
	MPEC needs to be calibrated?	Refer to dealer.
Loss of MPU light(s) or on.	Magnetic pick up out of adjustment?	Adjust magnetic pick up.
	Magnetic pick up dirty?	Clean magnetic pick up.

# EXPLANATION OF CODE IN REMARKS COLUMN

How to read the marks and remarks used in this parts book.

## Items Found In the “Remarks” Column

**Serial Numbers**-Where indicated, this indicates a serial number range (inclusive) where a particular part is used.

**Model Number**-Where indicated, this shows that the corresponding part is utilized only with this specific model number or model number variant.

## Items Found In the “Items Number” Column

All parts with same symbol in the number column, \*, #, +, %, or ■, belong to the same assembly or kit.

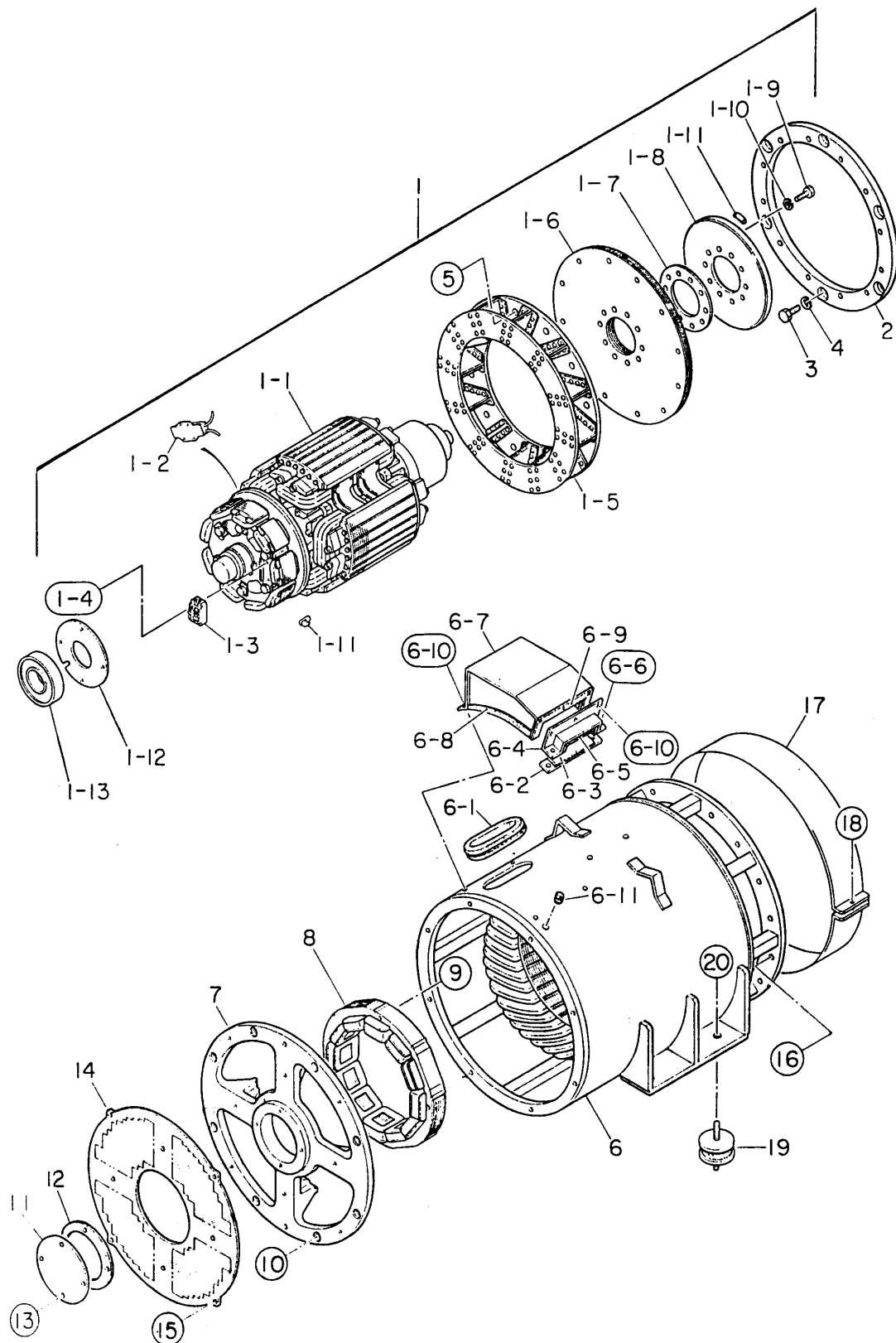
Note: If more than one of the same reference number is listed, the last one listed indicates newest (or latest) part available.

***DCA-400SSK W/KOMATSU SA6D140E-2  
DIESEL ENGINE 1 TO 3 UNITS***

<u>Qty.</u>	<u>P/N</u>	<u>Description</u>
10 .....	6128817051 .....	AIR FILTER
10 .....	6003117132 .....	FUEL FILTER
10 .....	6002111231 .....	OIL FILTER
5 .....	6004111171 .....	CARTRIDGE, CORROSION RESISTOR
1 .....	0601807307 .....	MAIN CIRCUIT BREAKER ..... UP TO S/N3703368
1 .....	0601870411 .....	MAIN CIRCUIT BREAKER ..... S/N3703369~
2 .....	0412122258 .....	ENGINE FAN BELT
1 .....	9212619610 .....	RADIATOR HOSE (UPPER)
1 .....	9212616930 .....	RADIATOR HOSE (LOWER)
1 .....	0601820625 .....	AUTOMATIC VOLTAGE REGULATOR
1 .....	0601840073 .....	VOLTAGE REGULATOR (RHEOSTAT)
1 .....	0601840121 .....	KNOB, VOLTAGE REGULATOR
1 .....	6008153730 .....	PILOT LAMP
2 .....	0601810244 .....	BULB, PILOT LAMP
1 .....	0602122200 .....	UNIT, OIL PRESSURE
1 .....	0602123206 .....	UNIT, WATER TEMPERATURE
1 .....	0602121052 .....	CHARGING AMMETER

# DCA-400SSK — GENERATOR ASSY.

## GENERATOR ASSY.



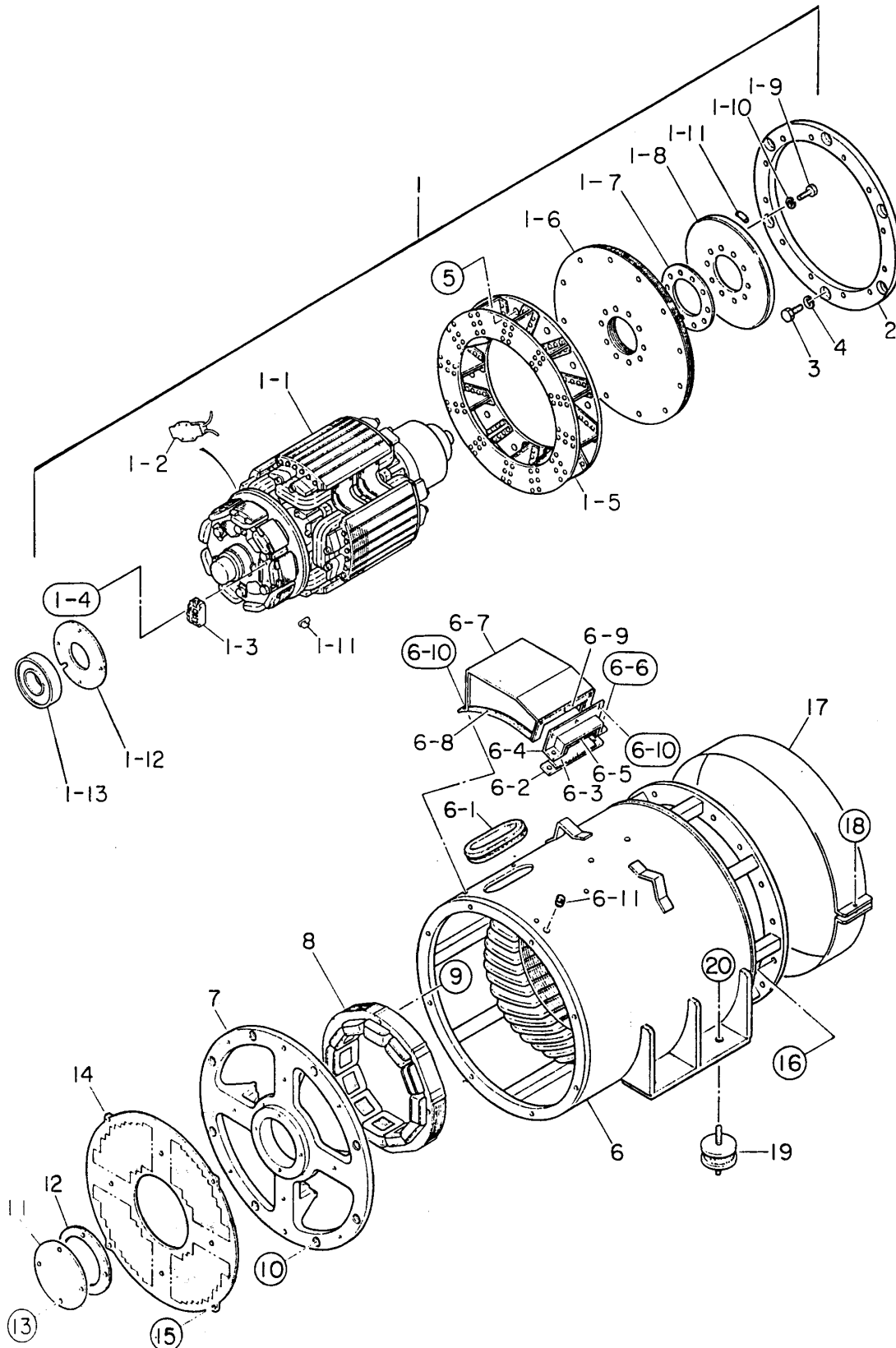
# DCA-400SSK — GENERATOR ASSY.

## GENERATOR ASSY.

<u>NO</u>	<u>PART NO</u>	<u>PART NAME</u>	<u>QTY.</u>	<u>REMARKS</u>
1	C3110100202	ROTOR ASSY.	1	
1-1		FIELD ASSY.	1	
1-2	0601842401	RESISTOR .....	2	... SMRK 80W 300 OHMS K
1-3	0601823282	RECTIFIER .....	1	... RM50TC-24
1-4	0018205020	HEX. SOCKET HEAD CAP SCREW	2	
	0040005000	LOCKWASHER	2	
	0041205000	PLAIN WASHER	2	
1-5	8201070002	FAN	1	
1-6	8201611004	COUPLING DISK	12	
1-7	C3164200004	WASHER, COUPLING HUB	1	
1-8	8201015003	BALANCING PLATE	1	
1-9	0012116045	HEX. HEAD BOLT	10	
1-10	0042616000	LOCKWASHER	10	
1-11	0601000209	BALANCING WEIGHT KIT	1	
1-12	C3112500004	BEARING FLANGE	1	
1-13	0071906315	BEARING .....	1	... 6315 DDU C3
2	8201614003	COUPLING RING	1	
3	0012116040	HEX. HEAD BOLT	6	
4	0042516000	LOCKWASHER	6	
5	0012112040	HEX. HEAD BOLT	12	
	0042512000	LOCKWASHER	12	
6	C3130100003	STATOR ASSY.	1	
6-1	0226200495	RUBBER SEAL	1	
6-2	8211323004	CLAMPER	1	
6-3	0223300172	RUBBER SEAL	1	
6-4	8211323103	CLAMPER	1	
6-5	0221200440	RUBBER SEAL	1	
6-6	0010110035	HEX. HEAD BOLT	2	
	0041210000	PLAIN WASHER	2	
6-7	C3132200003	COVER	1	
6-8	0226000290	RUBBER SEAL	2	
6-9	0225000590	RUBBER SEAL	1	
6-10	0017106020	HEX. HEAD BOLT	6	
6-11	0601850144	GROMMET	1	
7	C3154000002	END BRACKET	1	
8	C3138000003	FIELD ASSY., EXCITER	1	

# DCA-400SSK — GENERATOR ASSY.

## GENERATOR ASSY.



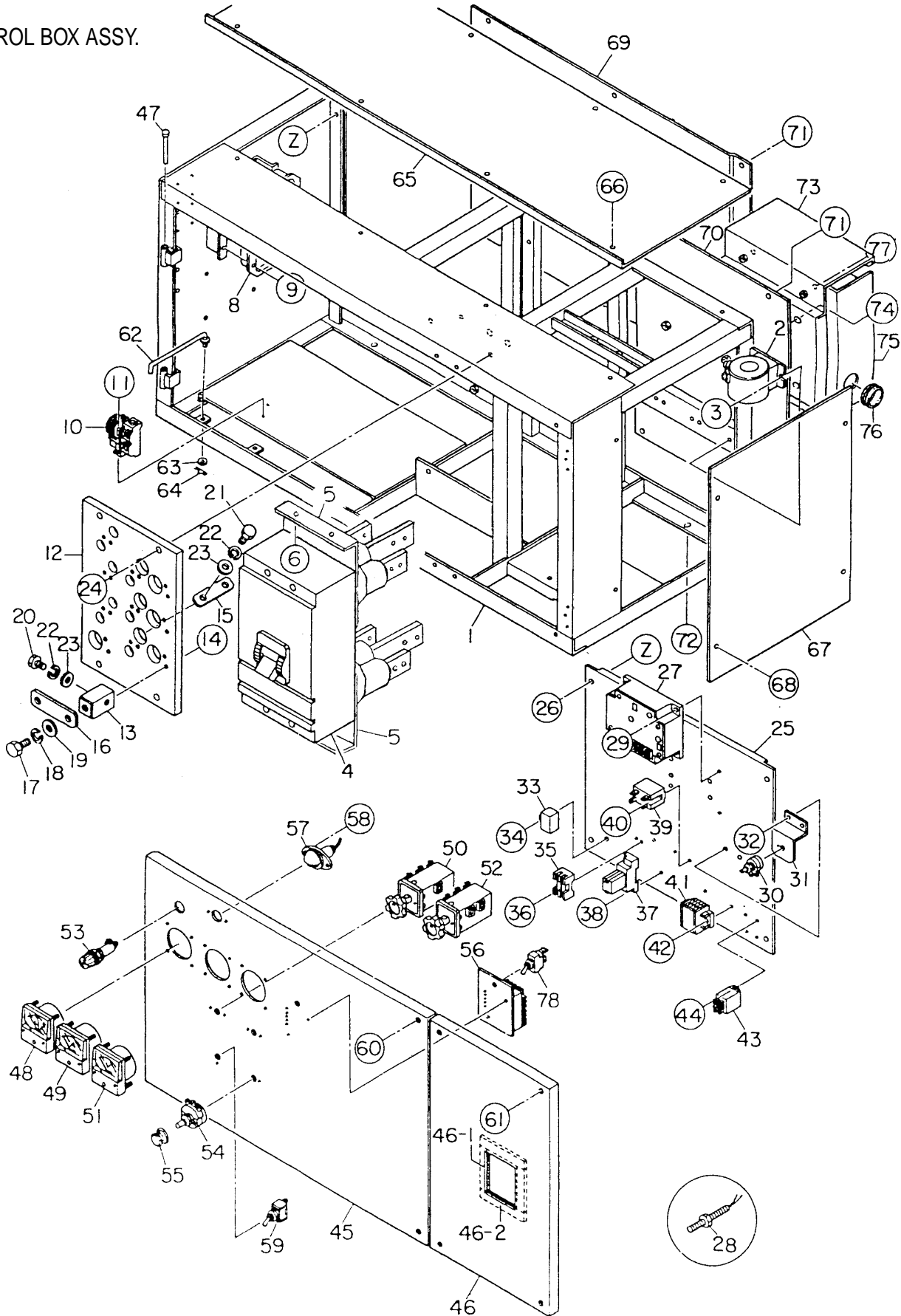
# DCA-400SSK — GENERATOR ASSY.

## GENERATOR ASSY.

<u>NO</u>	<u>PART NO</u>	<u>PART NAME</u>	<u>QTY.</u>	<u>REMARKS</u>
9	0012110080	HEX. HEAD BOLT	4	
	0042610000	LOCK WASHER	4	
	0041210000	PLAIN WASHER	4	
10	0017112045	HEX. HEAD BOLT	8	
11	C3154300104	COVER, BEARING	1	
12	C3154300004	GASKET, BEARING	1	
13	0010106060	HEX. HEAD BOLT	4	
	0040006000	LOCK WASHER	4	
	0041206000	PLAIN WASHER	4	
14	C3154400003	SUCTION COVER	1	
15	0017106016	HEX. HEAD BOLT	8	
16	0012112035	HEX. HEAD BOLT	16	
	0042512000	LOCK WASHER	16	
17	C313230014	COVER, FAN	1	
18	0010106030	HEX. HEAD BOLT	1	
	0041206000	PLAIN WASHER	1	
	020106050	NUT .....	1	REPLACES 0600815000
19	0605000061	RUBBER SUSPENSION	4	
20	0030016000	HEX. NUT	8	
	0040016000	LOCK WASHER	8	

# DCA-400SSK — CONTROL BOX ASSY.

CONTROL BOX ASSY.



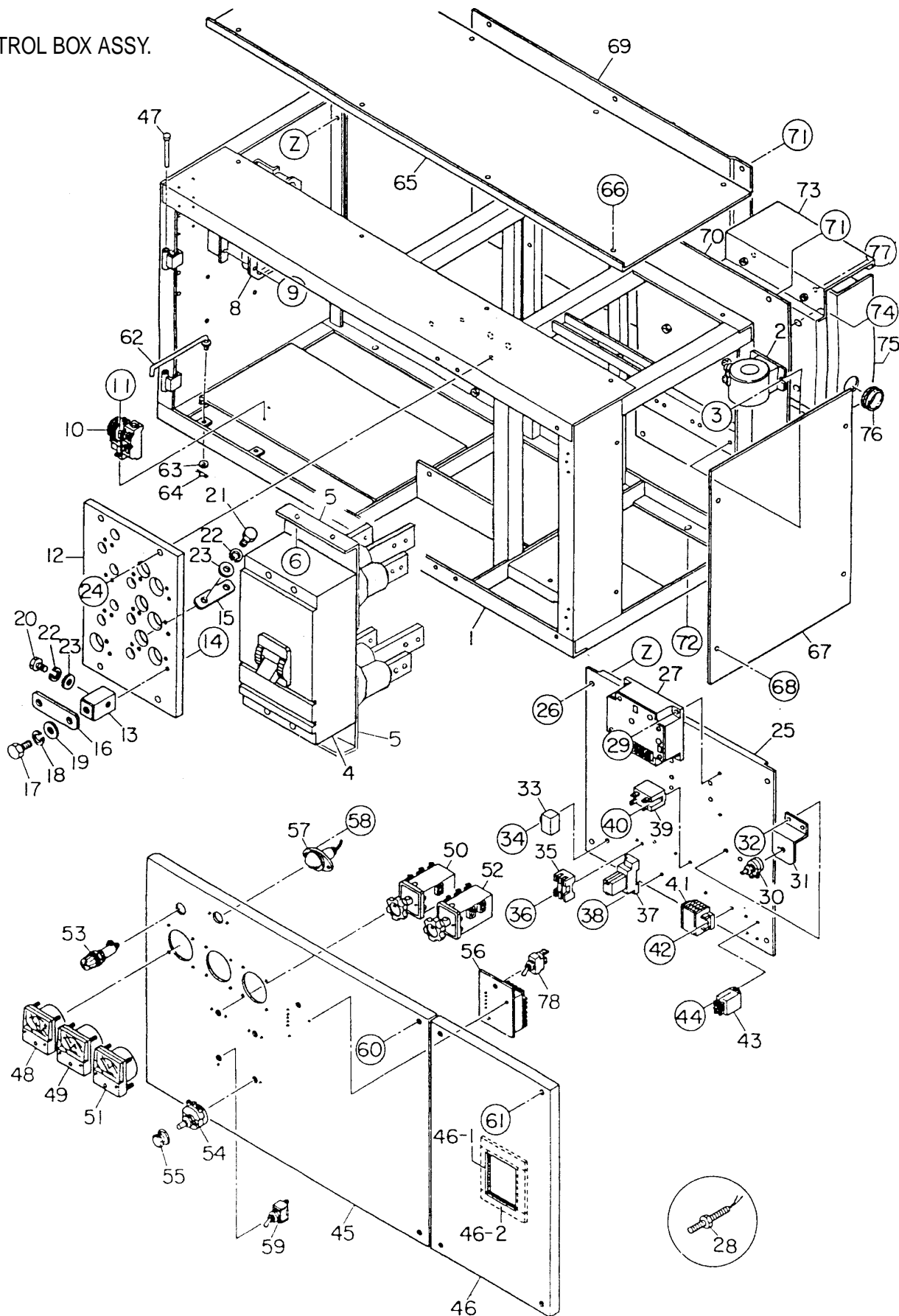
# DCA-400SSK — CONTROL BOX ASSY.

## CONTROL BOX ASSY.

<u>NO</u>	<u>PART NO</u>	<u>PART NAME</u>	<u>QTY.</u>	<u>REMARKS</u>
1	C3214000912	CONTROL BOX .....	1	UP TO S/N3703368
1	C3214001302	CONTROL BOX .....	1	S/N3703369~
2	0601801170	CURRENT TRANSFORMER .....	3	CW-5L 750/5A
3	0027106016	MACHINE SCREW	6	
4	0601807307	CIRCUIT BREAKER;XS1200NE 1060A ...	1	UP TO S/N3703368
4	0601870411	CIRCUIT BREAKER;NG31000 1000A .....	1	S/N3703369~
4-1	0601802525	HANDLE, CIRCUIT BREAKER .....	1	UP TO S/N3703368
5	C3214600004	BRACKET, CIRCUIT BREAKER .....	2	UP TO S/N3703368
5	C3214600204	BRACKET, CIRCUIT BREAKER (UPPER)	1	S/N3703369~
	C3214600304	BRACKET, CIRCUIT BREAKER (LOWER)	1	S/N3703369~
6	0017108020	HEX. HEAD BOLT	4	
7	0021008045	MACHINE SCREW .....	4	UP TO S/N3703368
	0040008000	LOCK WASHER .....	4	UP TO S/N3703368
	0041208000	PLAIN WASHER .....	4	UP TO S/N3703368
8	0601820625	AUTOMATIC VOLTAGE REGULATOR .....	1	NTA5A2T
9	0027105016	MACHINE SCREW	4	
10	0601820892	OVER CURRENT RELAY .....	1	THN20HZ
11	0027104016	MACHINE SCREW	2	
12	C3274000003	CHANGE-OVER BOARD, VOLTAGE	1	
13	8221852104	CHANGE TERMINAL	10	
14	0017108030	HEX. HEAD BOLT	20	
15	C2277200004	TERMINAL PLATE	3	
16	8221853104	CHANGE PLATE	6	
17	0801830804	HEX. HEAD BOLT	10	
18	0040016000	LOCK WASHER	10	
19	0041416000	PLAIN WASHER	10	
20	0801830704	HEX. HEAD BOLT	13	
21	8201852504	HEX. HEAD BOLT	3	
22	0040012000	LOCK WASHER	16	
23	0041412000	PLAIN WASHER	16	
24	0017110030	HEX. HEAD BOLT	4	
25	C3262500003	SET PANEL, ELECTRIC PARTS	1	
26	0017108020	HEX. HEAD BOLT	4	
27	DYN110654000024	CONTROLLER .....	1	REPLACES 0602202598
28	DYNT11200	SPEED SENSOR .....	1	REPLACES 0602120498
29	0027104020	MACHINE SCREW	4	

# DCA-400SSK — CONTROL BOX ASSY.

CONTROL BOX ASSY.



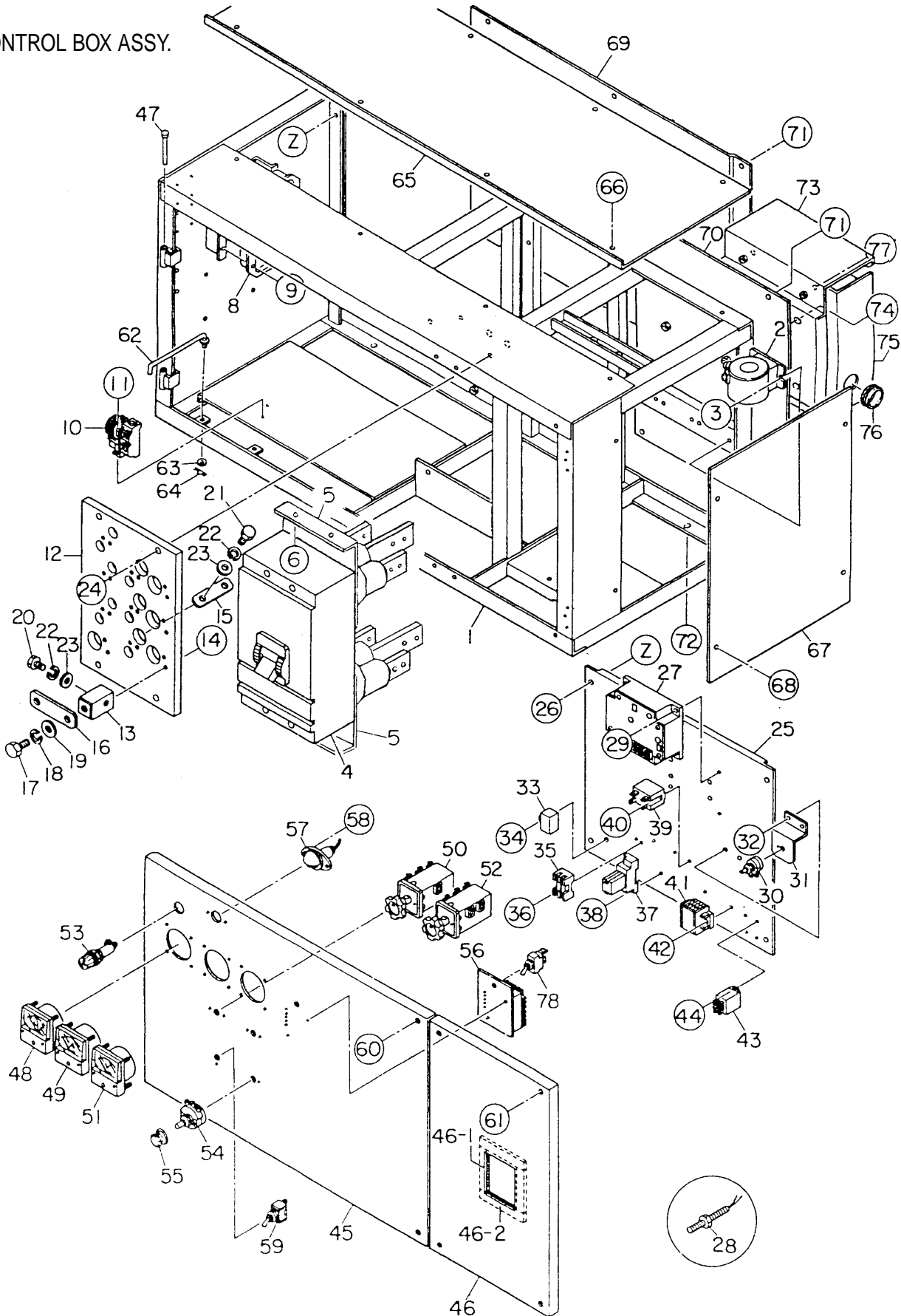
# DCA-400SSK — CONTROL BOX ASSY.

## CONTROL BOX ASSY.

<u>NO</u>	<u>PART NO</u>	<u>PART NAME</u>	<u>QTY.</u>	<u>REMARKS</u>
30	0601840009	RHEOSTAT .....	1	RA20A2SE502BJ 2W 5K OHMS
31	C3262600004	BRACKET	1	
32	0017106016	HEX. HEAD BOLT	2	
33	0602201911	UNIT, BATTERY SENSOR .....	1	C7038A0000
34	0027106016	MACHINE SCREW	1	
35	0601806671	FUSE (LEFT) .....	1	15A
	0601802149	FUSE (RIGHT) .....	1	10A
	0601802211	HOLDER, FUSE	1	
36	0027104020	MACHINE SCREW	2	
37	0601827655	RELAY .....	1	LY2DDC24V
	0601823109	SOCKET .....	1	PTF08A
	PYCA1	HOLDER .....	1	REPLACES 0601824400
38	0027104020	MACHINE SCREW	2	
39	0601823706	RELAY .....	1	HE1A DC24V
40	0027104014	MACHINE SCREW	2	
41	0601815402	TERMINAL BOARD .....	1	TS14 4P
42	0027104020	MACHINE SCREW	2	
43	0601824542	RELAY .....	2	HH62SDC24V
44	0027103010	MACHINE SCREW	4	
45	C3224001303	CONTROL PANEL	1	
46	C3224001203	CONTROL PANEL	1	
46-1	0228800100	RUBBER SEAL	2	
46-2	0228800124	RUBBER SEAL	2	
47	0605011211	PIN	2	
48	0601807622	FREQUENCY METER .....	1	RSC80F 45~65HZ 220V
49	0601806987	AC AMMETER .....	1	RSS80 0~750A 0~1500A
50	0601801040	CHANGE-OVER SWITCH, AMMETER ....	1	SL2AS
51	0601806887	AC VOLTMETER .....	1	RSR80 0~600V
52	0601801041	CHANGE-OVER SWITCH, VOLTMETER .	1	SL2VS
53	0601810072	PILOT LAMP .....	1	LP132DC 220V
	0601810261	BULB .....	1	CT13W
54	0601840073	RHEOSTAT (VOLTAGE REGULATOR) .....	1	RA20A2SE102BJ 2W 1K OHM
55	0601840121	KNOB	1	
56	ECU9988N	ENGINE CONTROLLER .....	1	REPLACES 0602202545
	0600500091	DECAL; ENGINE CONTROLLER .....	1	
57	0601810161	PANEL LIGHT .....	1	V325070
	0601810214	BULB	1	
58	0207004000	HEX. NUT	2	
59	0601830710	SWITCH, PANEL LIGHT .....	1	S301T

# DCA-400SSK — CONTROL BOX ASSY.

CONTROL BOX ASSY.



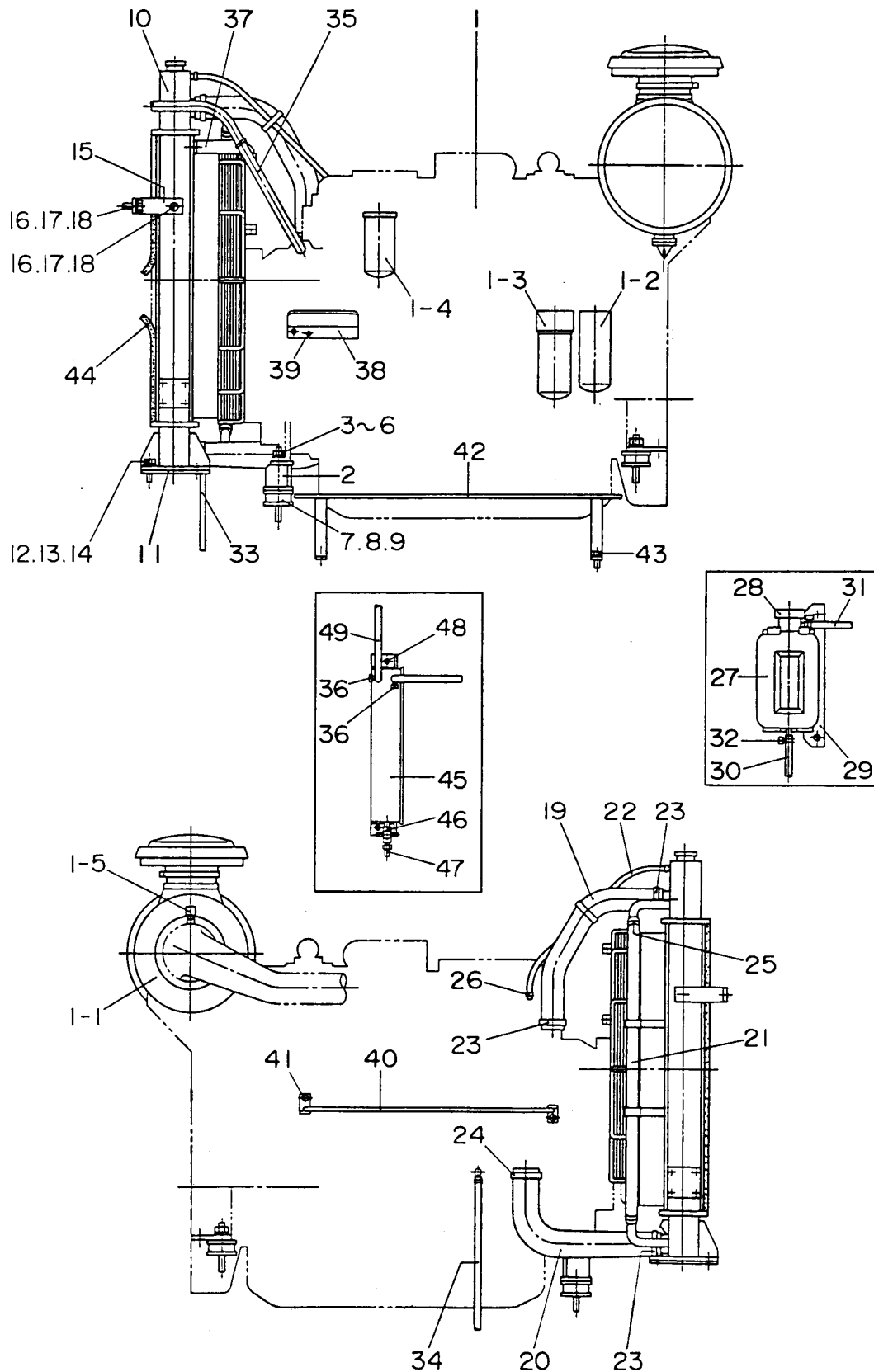
# DCA-400SSK — CONTROL BOX ASSY.

## CONTROL BOX ASSY.

<u>NO</u>	<u>PART NO</u>	<u>PART NAME</u>	<u>QTY.</u>	<u>REMARKS</u>
60	C9221100004	HEX. HEAD BOLT	2	
	0040008000	LOCK WASHER	2	
	0041208000	PLAIN WASHER	2	
	0080200007	SNAP RING	2	
61	0017108040	HEX. HEAD BOLT	4	
62	3871824004	STOPPER, CONTROL PANEL	1	
63	0041206000	PLAIN WASHER	1	
64	0605010502	SNAP PIN	1	
65	8221814804	COVER, CONTROL BOX	1	
66	0017108020	HEX. HEAD BOLT	8	
67	8224117004	SIDE PANEL, CONTROL BOX	1	
68	0017108020	HEX. HEAD BOLT	4	
69	C3215400004	PANEL, CONTROL BOX	1	
70	C3215400104	PANEL, CONTROL BOX	1	
71	0017108020	HEX. HEAD BOLT	8	
72	012210035	HEX. HEAD BOLT .....	4	REPLACES 0017110035
	0207010000	HEX. NUT	4	
73	C4262600004	BRACKET, BATTERY CHARGER	1	
74	0017108020	HEX. HEAD BOLT	4	
75	FC24102011U	BATTERY CHARGER .....	1	REPLACES 0601823091
76	0601850263	GROMMET	2	
77	0017106016	HEX. HEAD BOLT	4	
78	0601830765	SWITCH .....	1	S303T

# DCA-400SSK — ENGINE RADIATOR ASSY.

ENGINE & RADIATOR ASSY.



# DCA-400SSK — ENGINE RADIATOR ASSY.

## ENGINE & RADIATOR ASSY.

<u>NO</u>	<u>PART NO</u>	<u>PART NAME</u>	<u>QTY.</u>	<u>REMARKS</u>
1	C3925200004	ENGINE .....	1	KOMATSU SA6D140E-2
1-1	6128817051	ELEMENT, AIR CLEANER .....	1	REPLACES 0602040157
1-2	6002111231	CARTRIDGE, OIL FILTER .....	1	REPLACES 0602041146
1-3	6003117132	CARTRIDGE, FUEL FILTER .....	1	REPLACES 0602042157
1-4	6004111171	CARTRIDGE, CORROSION RESISTOR..	1	REPLACES 0602045144
1-5	0602040678	DUST SENSOR .....	1	REX018126
2	C3304200104	ENGINE FOOT	1	
3	0010118060	HEX. HEAD BOLT	2	
4	0030018000	HEX. NUT	2	
5	0040018000	LOCK WASHER	2	
6	0041218000	PLAIN WASHER	4	
7	0605000061	RUBBER SUSPENSION	4	
8	0030016000	HEX. NUT	8	
9	0040016000	LOCK WASHER	8	
10	6212619902	RADIATOR .....	1	REPLACES 0602011943
11	6995619230	RUBBER SHEET .....	2	REPLACES 0605000085
12	0010120055	HEX. HEAD BOLT	4	
13	0040020000	LOCK WASHER	4	
14	0041220000	PLAIN WASHER	4	
15	C3311100204	BRACKET, RADIATOR	2	
16	0010112025	HEX. HEAD BOLT	4	
17	0040012000	LOCK WASHER	4	
18	0041212000	PLAIN WASHER	4	
19	6212619610	RADIATOR HOSE .....	1	REPLACES 0602013962
20	6212616930	RADIATOR HOSE .....	1	REPLACES 0602014467
21	0726102612	RADIATOR HOSE .....	1	REPLACES 0602013963
22	6138619260	RADIATOR HOSE .....	1	REPLACES 0602013062
23	0728100909	HOSE BAND .....	6	REPLACES 0602014056
24	0728101029	HOSE BAND .....	2	REPLACES 0602014350
25	0728100489	HOSE BAND .....	2	REPLACES 0602014351
26	0728100167	HOSE BAND .....	2	REPLACES 0602014059
27	0802081003C	RESERVE TANK .....	1	REPLACES 0802081003
28	0802010900	CAP, RESERVE TANK .....	1	REPLACES 0602010900
29	C3317100103	BRACKET, RESERVE TANK	1	



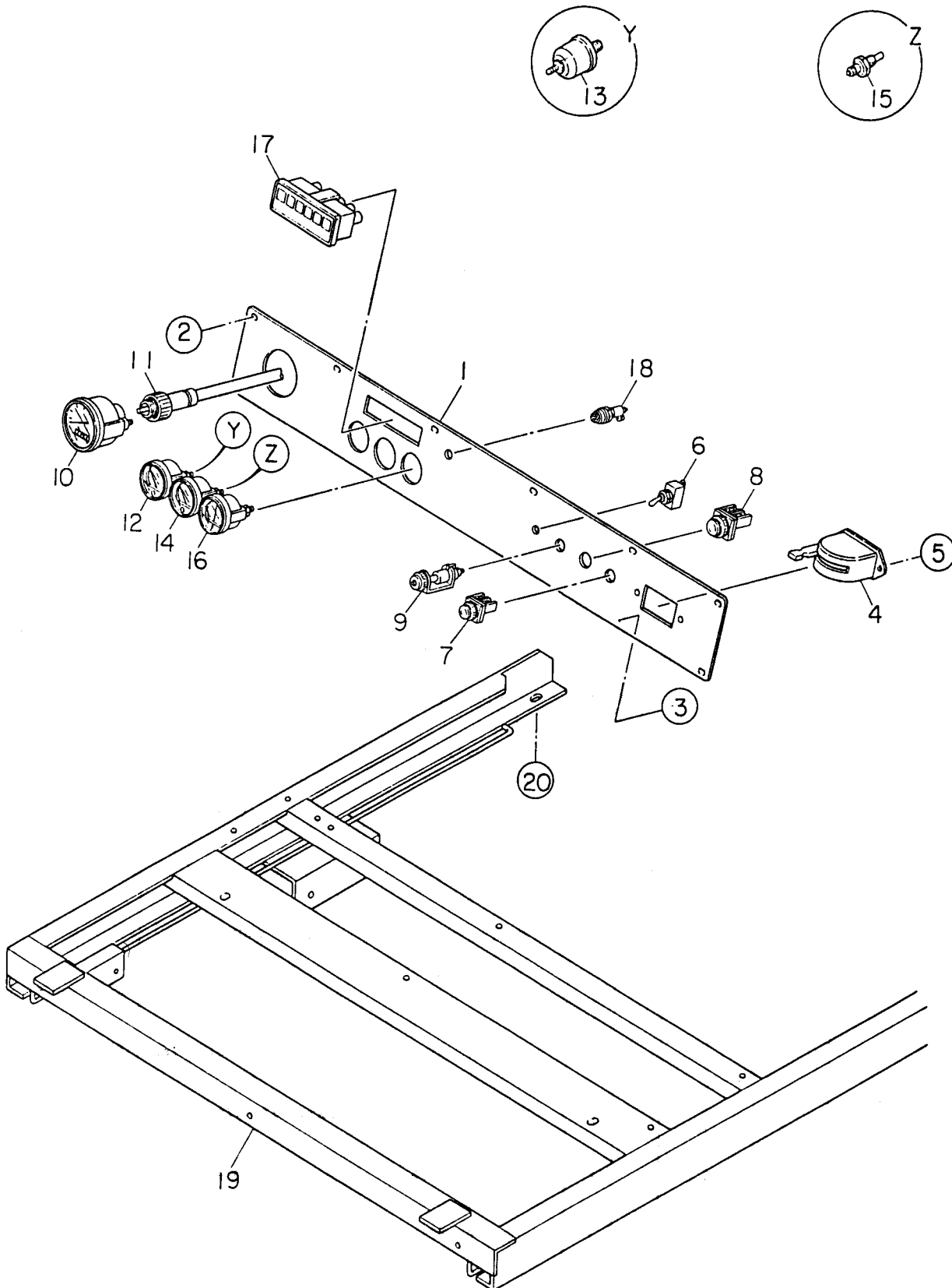
# DCA-400SSK — ENGINE RADIATOR ASSY.

## ENGINE & RADIATOR ASSY.

<u>NO</u>	<u>PART NO</u>	<u>PART NAME</u>	<u>QTY.</u>	<u>REMARKS</u>
30	0199101150	HOSE	1	
31	0193601500	HOSE	1	
32	0605515013	HOSE BAND	2	
33	0194700400	HOSE	1	
34	0194700450	HOSE	1	
35	0268500580	HOSE	1	
36	0605512074	HOSE BAND	4	
37	C3327200004	HOSE CLAMPER	1	
38	8212044103	OIL PANEL	1	
39	0017110025	HEX. HEAD BOLT	2	
40	C3358300204	CLAMPER ROD	1	
41	0017110025	HEX. HEAD BOLT	2	
42	8212256104	CLAMPER ROD	1	
43	0019208020	HEX. HEAD BOLT	2	
44	8215103504	RUBBER SEAL	1	
45	C3325100103	OIL MIST TANK	1	
46	0603325011	VALVE .....	1	..... BBS7715
47	0602022293	HOSE JOINT	1	
48	011008020	HEX. HEAD BOLT .....	2	..... REPLACES 0017108020
49	0268500950	HOSE	1	

# DCA-400SSK — ENGINE OPERATING PANEL ASSY.

ENGINE OPERATING PANEL ASSY.



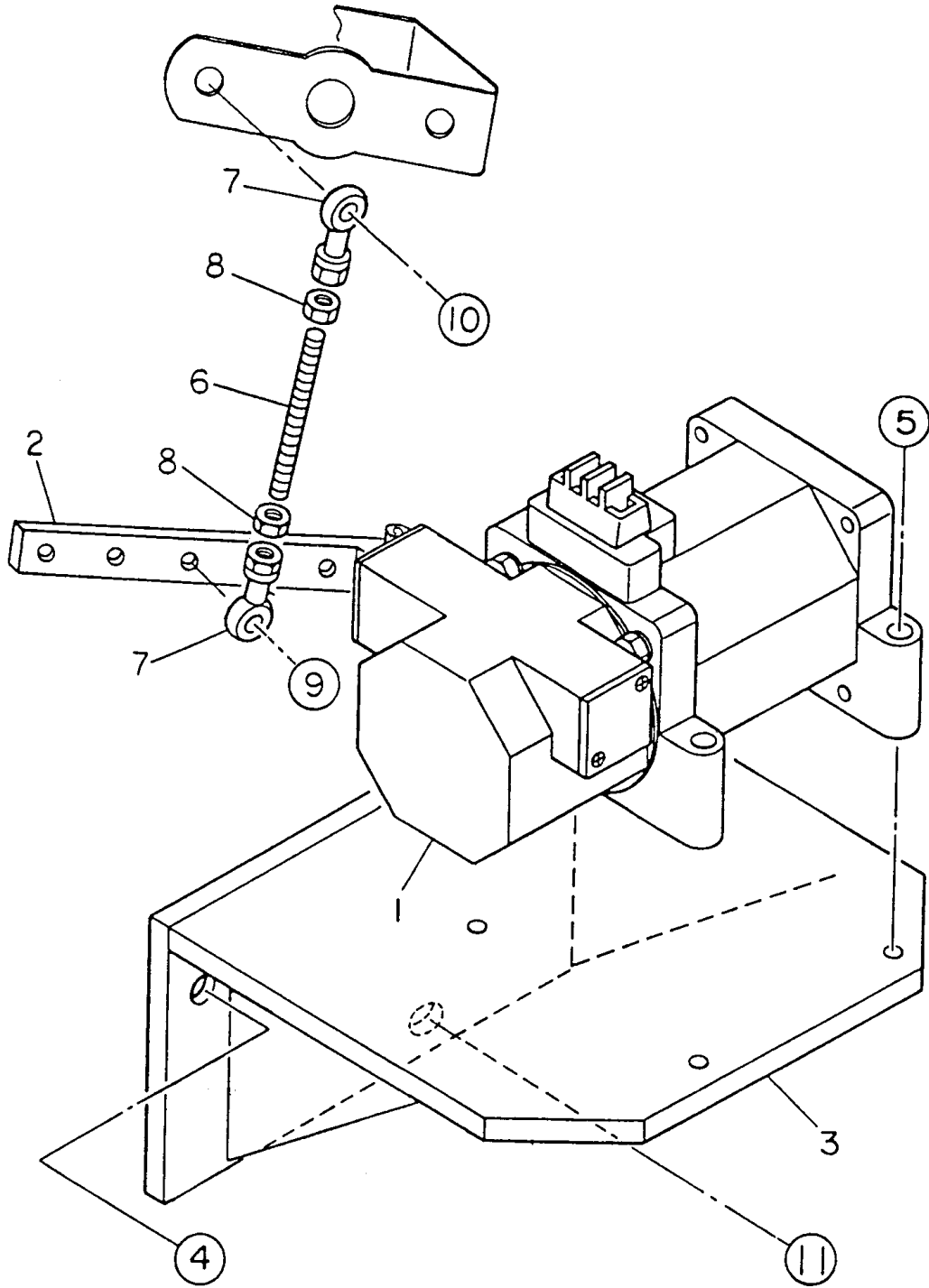
# DCA-400SSK — ENGINE OPERATING PANEL ASSY.

## ENGINE OPERATING PANEL ASSY.

<u>NO</u>	<u>PART NO</u>	<u>PART NAME</u>	<u>QTY.</u>	<u>REMARKS</u>
1	C3353100003	OPERATING PANEL	1	
2	0017106016	HEX. HEAD BOLT	8	
3	0207006000	HEX. NUT	4	
4	0602101000	BATTERY SWITCH .....	1	9827300090
5	0021008080	MACHINE SCREW	2	
	0030008000	HEX. NUT	2	
	0040008000	LOCK WASHER	2	
	0041208000	PLAIN WASHER	2	
6	0601830710	ENGINE SPEED SWITCH .....	1	S301T
7	0601831557	EMERGENCY STOP BUTTON .....	1	AR22V2R01R
8	0601830448	PREHEAT BUTTON .....	1	AH25FB10
9	6008153730	PREHEAT LAMP .....	1	REPLACES 0602102055
10	0602120054	TACHOMETER .....	1	25000KX4110
11	0602120156	CABLE, TACHOMETER .....	1	62500KA4210 L=3000
12	0602122060	OIL PRESSURE GAUGE .....	1	42000KX1410
13	0602122200	UNIT, OIL PRESSURE .....	1	53000AC0101
14	0602123061	WATER TEMPERATURE GAUGE .....	1	40000KX0910
15	0602123206	UNIT, WATER TEMPERATURE .....	1	51400KS0600
16	0602121052	CHARGING AMMETER .....	1	43000KV0300
17	0602115014	MONITOR .....	1	V3376600000
18	0602103090	DETECTED LAMP, FUEL TANK	1	
	0601810244	BULB	1	
19	C3484000103	SET FRAME	1	
20	0010110030	HEX. HEAD BOLT	2	
	0030010000	HEX. NUT	2	
	0040010000	LOCK WASHER	2	
	0041210000	PLAIN WASHER	4	

# DCA-400SSK — GOVERNOR ACTUATOR ASSY.

GOVERNOR ACTUATOR ASSY.



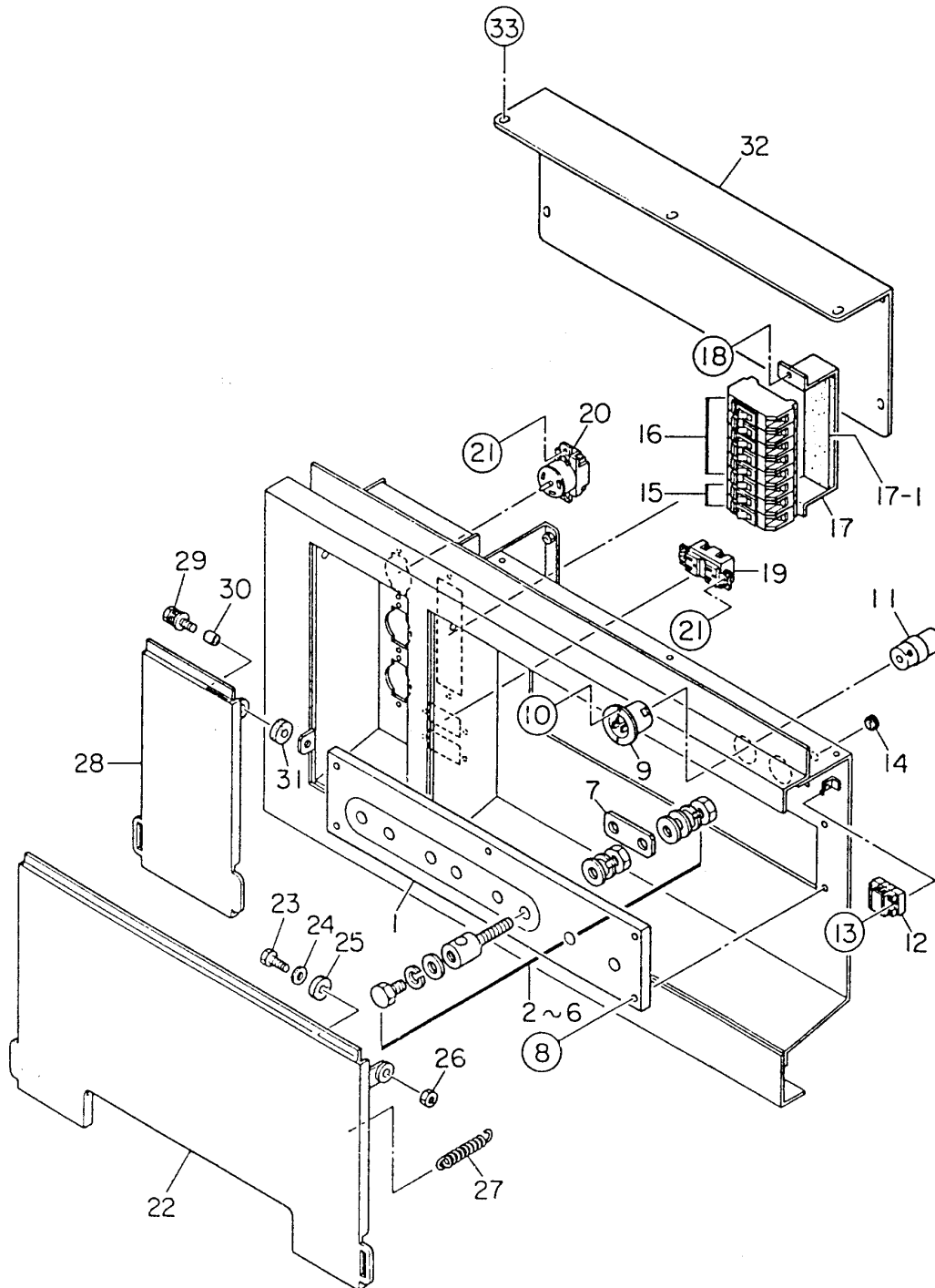
# DCA-400SSK — GOVERNOR ACTUATOR ASSY.

## GOVERNOR ACTUATOR ASSY.

<u>NO</u>	<u>PART NO</u>	<u>PART NAME</u>	<u>QTY.</u>	<u>REMARKS</u>
1	DYNC11020300024	ACTUATOR .....	1	REPLACES 0602150092
2	DYNC182	LEVER .....	1	REPLACES 0602211090
3	C3356200004	BRACKET, ACTUATOR	1	
4	0012110060	HEX. HEAD BOLT	2	
	031110160	PLAIN WASHER .....	2	REPLACES 0041210000
5	0015306070	SOCKET HEAD CAP SCREW	4	
	0040006000	LOCK WASHER	4	
	952404470	PLAIN WASHER .....	4	REPLACES 0041206000
	020106050	HEX. NUT .....	4	REPLACES 0038406000
6	0602211091	ROD	1	
7	0602180190	BALL JOINT 1/4-28	2	
8	0602211092	HEX. NUT	2	
9	011606025	HEX. HEAD BOLT .....	1	REPLACES 0010106025
	020106050	HEX. NUT .....	1	REPLACES 0038406000
10	011606025	HEX. HEAD BOLT .....	1	REPLACES 0010106025
	020106050	HEX. NUT .....	1	REPLACES 0038406000
	952404470	PLAIN WASHER .....	1	REPLACES 0041206000
11	0012110040	HEX. HEAD BOLT	1	
	031110160	PLAIN WASHER .....	1	REPLACES 0041210000

# DCA-400SSK — OUTPUT TERMINAL ASSY.

## OUTPUT TERMINAL ASSY.



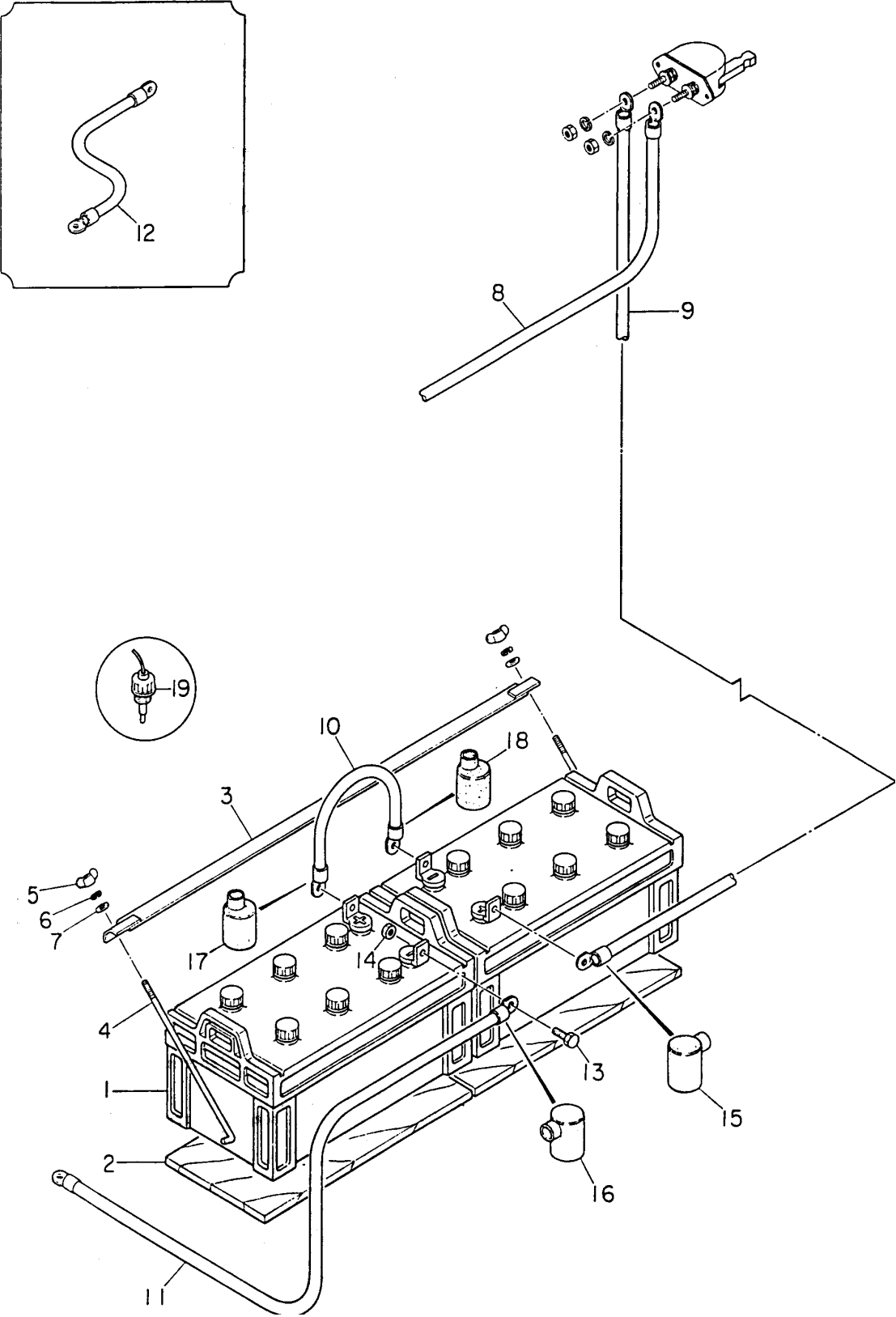
# DCA-400SSK — OUTPUT TERMINAL ASSY.

## OUTPUT TERMINAL ASSY.

<u>NO</u>	<u>PART NO</u>	<u>PART NAME</u>	<u>QTY.</u>	<u>REMARKS</u>
1	8221860203	SET BOARD, OUTPUT TERMINAL	1	
2	0801030404	SET PLATE, OUTPUT TERMINAL	8	
3	0801830904	HEX. HEAD BOLT	8	
4	0039320000	HEX. NUT	16	
5	0040020000	LOCK WASHER	24	
6	0041420000	PLAIN WASHER	32	
7	3501860604	TERMINAL PLATE	3	
8	0019110050	HEX. HEAD BOLT	5	
	0042310000	LOCK WASHER	5	
	0042410000	PLAIN WASHER	5	
9	0601811189	RECEPTACLE .....	2	HBL5378C 125V 20A
10	0027103010	MACHINE SCREW	4	
11	0601812537	ADAPTER .....	1	HBL5369C 125V 20A
12	0601815324	TERMINAL BOARD	1	
13	0027104020	MACHINE SCREW	2	
14	0601850275	GROMMET	1	
15	0601805313	CIRCUIT BREAKER, KM51B 265V 20A ...	2	UP TO S/N3703368
15	0601808803	CIRCUIT BREAKER, QOU120B 20A .....	2	S/N3703369~
16	0601805840	CIRCUIT BREAKER, KM52 265V 50A .....	3	UP TO S/N3703368
16	0601808804	CIRCUIT BREAKER, QOU250B 50A .....	3	S/N3703369~
17	C1261600204	BRACKET, CIRCUIT BREAKER .....	1	UP TO S/N3703368
17	C3261600704	BRACKET, CIRCUIT BREAKER .....	1	S/N3703369~
17-1	0223300200	RUBBER CUSHION .....	1	UP TO S/N3703368
17-1	0221200150	RUBBER CUSHION .....	1	S/N3703369~
18	0017106020	HEX. HEAD BOLT	2	
19	0601812598	RECEPTACLE .....	2	GF530EM
20	0601812565	RECEPTACLE .....	2	CS6369
21	0027104016	MACHINE SCREW	10	
	0030004000	HEX. NUT	10	
	0041204000	PLAIN WASHER	10	
22	C3237100113	COVER, OUTPUT TERMINAL	1	
23	0019112045	HEX. HEAD BOLT	2	
24	0042412000	PLAIN WASHER	2	
25	0805015604	STAY RUBBER	2	
26	0205012000	HEX. NUT	2	
27	0845043704	SPRING	2	
28	C0237101504	COVER	1	
29	0017110040	HEX. HEAD BOLT	2	
30	0845054204	COLLAR	1	
31	0805015604	STAY RUBBER	1	
32	C3237100214	COVER	1	
33	0017108020	HEX. HEAD BOLT	7	

# DCA-400SSK — BATTERY ASSY.

BATTERY ASSY.

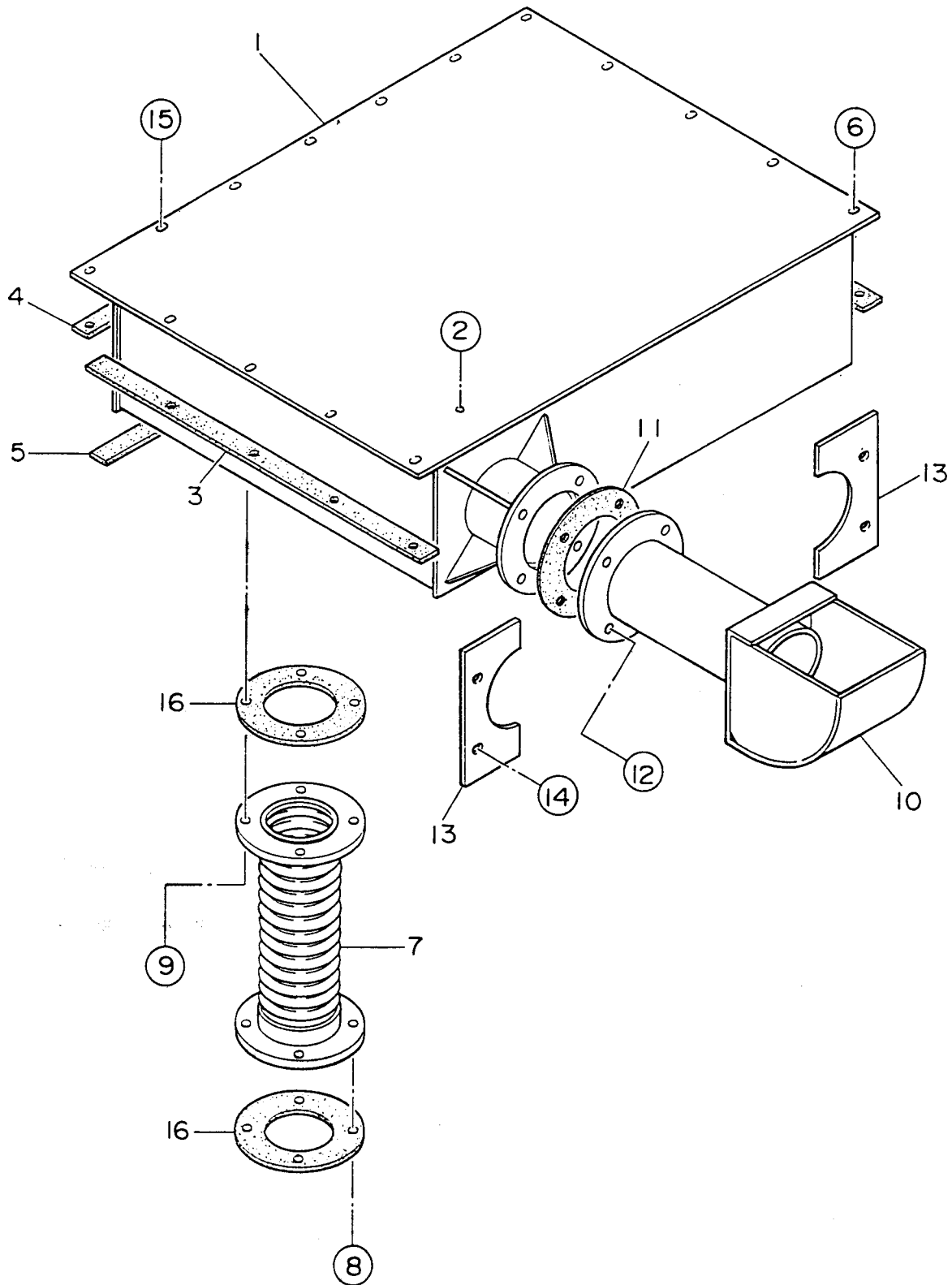


## BATTERY ASSY.

<u>NO</u>	<u>PART NO</u>	<u>PART NAME</u>	<u>QTY.</u>	<u>REMARKS</u>
1	0168719052	BATTERY .....	2	190H52
2	0805018904	BATTERY SHEET	2	
3	0805006404	BATTERY BAND	1	
4	0805006504	BATTERY BOLT	2	
5	0037808000	WING NUT	2	
6	0040008000	LOCK WASHER	2	
7	0041208000	PLAIN WASHER	2	
8	C3347600004	BATTERY CABLE	1	
9	C3347600104	BATTERY CABLE	1	
10	C3347600304	BATTERY CABLE	1	
11	C3347600204	BATTERY CABLE	1	
12	C3347200004	EARTH CABLE	1	
13	0347010030	HEX. HEAD BOLT	4	
14	0208110000	HEX. NUT	4	
15	0845040114	TERMINAL CAP	1	
16	0845041004	TERMINAL CAP	1	
17	0845040214	TERMINAL CAP	1	
18	0845041104	TERMINAL CAP	1	
19	0602220205	BATTERY SENSOR	1	

# DCA-400SSK — MUFFLER ASSY.

MUFFLER ASSY.

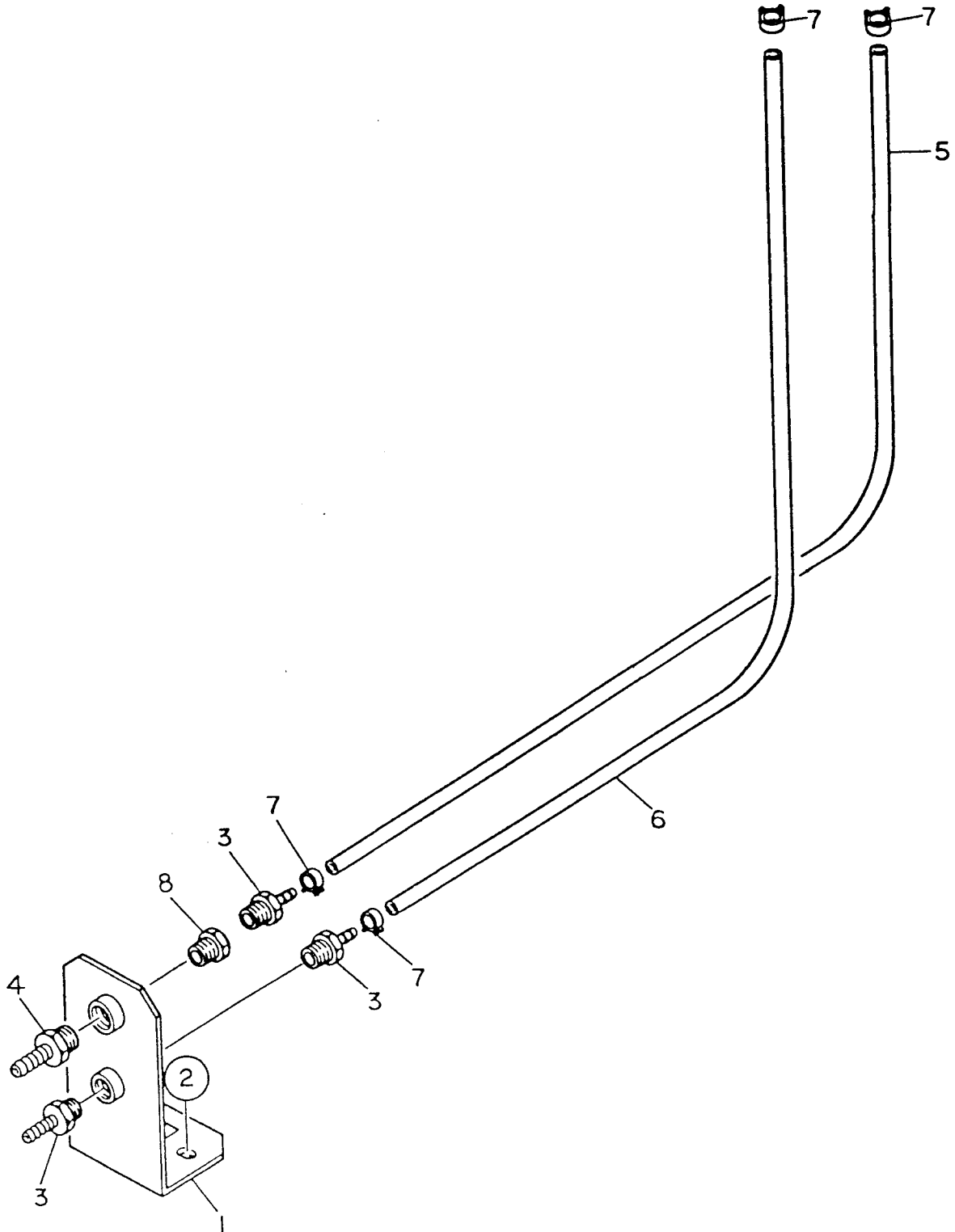


MUFFLER ASSY.

<u>NO</u>	<u>PART NO</u>	<u>PART NAME</u>	<u>QTY.</u>	<u>REMARKS</u>
1	C3331100102	MUFFLER	1	
2	0019110020	HEX. HEAD BOLT	4	
3	C3334200204	PACKING	2	
4	C3334200504	PACKING	1	
5	C3334200604	PACKING	1	
6	0019210025	HEX. HEAD BOLT	8	
7	C3334000413	EXHAUST PIPE	1	
8	0010316080	HEX. HEAD BOLT	4	
	0030316000	HEX. NUT	8	
	0042516000	LOCK WASHER	4	
	0041616000	PLAIN WASHER	8	
9	0010316050	HEX. HEAD BOLT	4	
	0042516000	LOCK WASHER	4	
	0041616000	PLAIN WASHER	4	
10	8212355003	OUTLET PIPE	1	
11	C3334200704	GASKET	1	
12	0019112045	HEX. HEAD BOLT	4	
	0030012000	HEX. NUT	4	
	0042312000	LOCK WASHER	4	
	0042412000	PLAIN WASHER	8	
13	8225125604	COVER	2	
14	0019108020	HEX. HEAD BOLT	4	
	0207008000	HEX. NUT	4	
	0042308000	LOCK WASHER	4	
	0042408000	PLAIN WASHER	4	
15	0019110030	HEX. HEAD BOLT	7	
	0042310000	LOCK WASHER	7	
	0042410000	PLAIN WASHER	7	
16	C3334200804	GASKET	2	

# DCA-400SSK — FUEL PIPING ASSY.

FUEL PIPING ASSY.



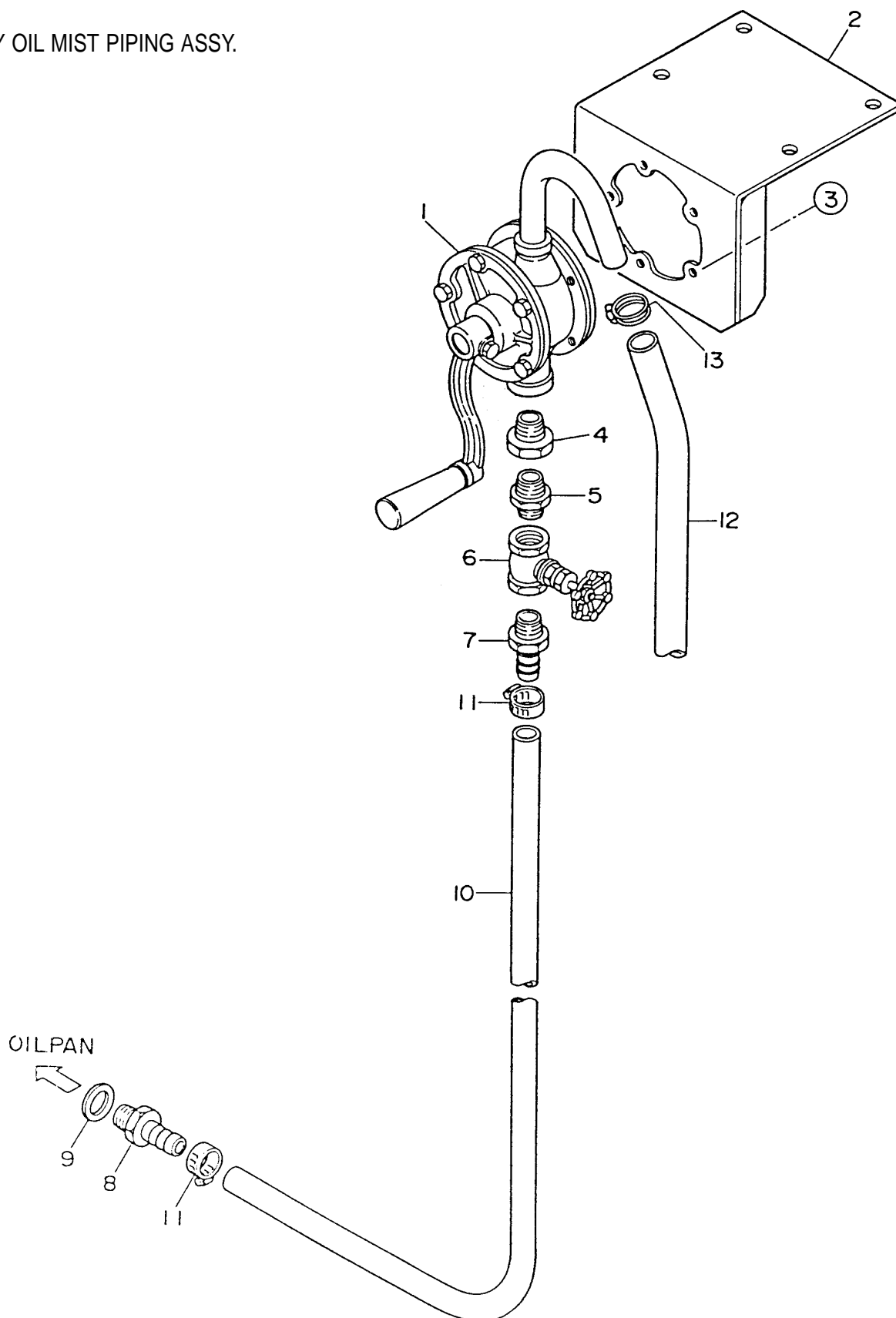
## DCA-400SSK — FUEL PIPING ASSY.

### FUEL PIPING ASSY.

<u>NO</u>	<u>PART NO</u>	<u>PART NAME</u>	<u>QTY.</u>	<u>REMARKS</u>
1	C4368700104	BRACKET	1	
2	0017110025	HEX. HEAD BOLT	2	
3	0602022284	HOSE JOINT	1	
4	0602022203	HOSE JOINT	3	
5	0131708060	BUSHING	1	
6	0130506000	SERVICE T	1	
7	6185517204	HOSE JOINT	1	
8	0191302700	SUCTION HOSE	1	
9	0191302600	RETURN HOSE	1	
10	0191003650	RETURN HOSE	1	
11	0605515109	HOSE BAND	4	
12	0605515013	HOSE BAND	2	

# DCA-400SSK— BLOW-BY OIL MIST PIPING ASSY.

BLOW-BY OIL MIST PIPING ASSY.



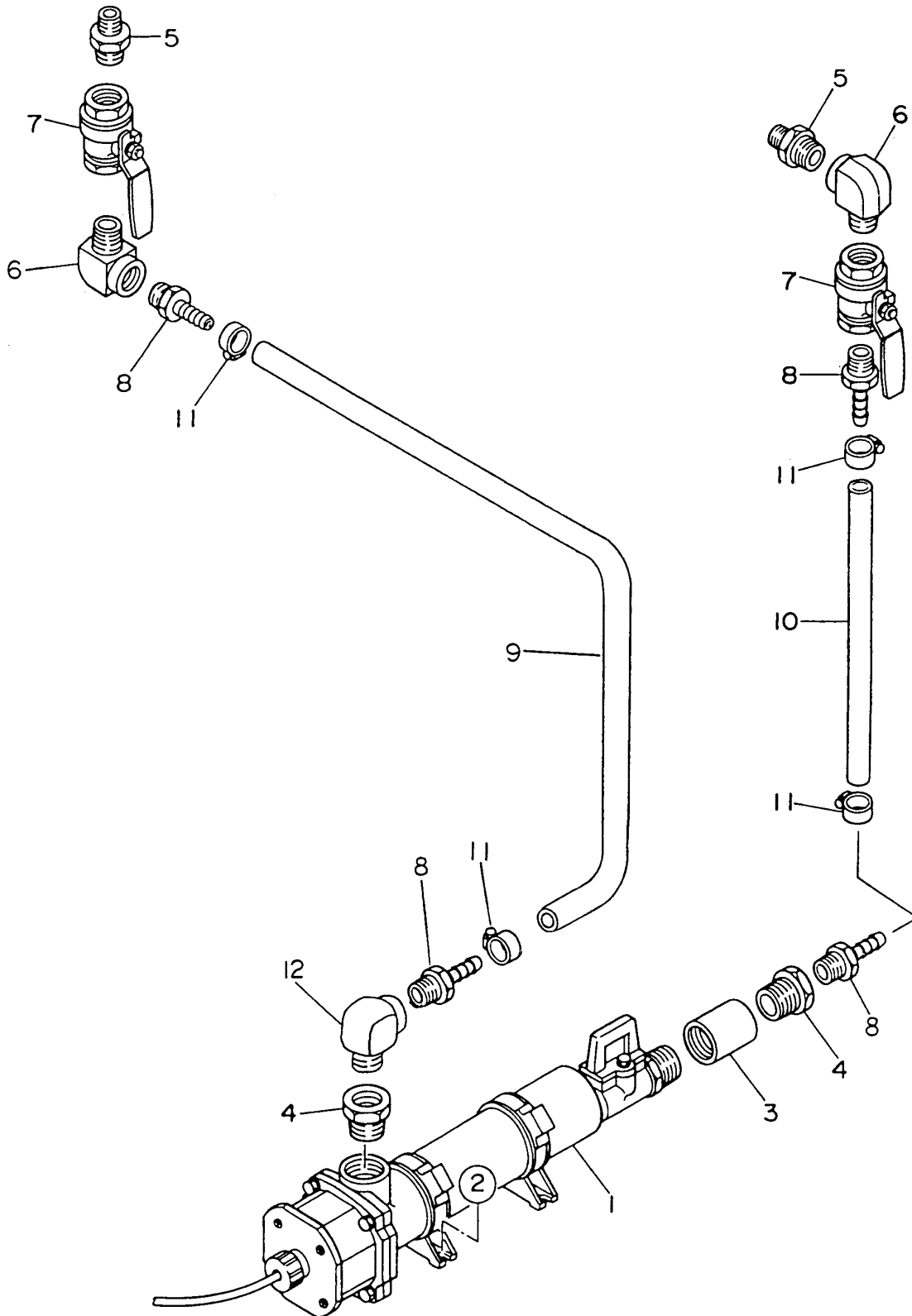
# DCA-400SSK — BLOW-BY OIL MIST PIPING ASSY.

## BLOW-BY OIL MIST PIPING ASSY.

<u>NO</u>	<u>PART NO</u>	<u>PART NAME</u>	<u>QTY.</u>	<u>REMARKS</u>
1	0602023040	PUMP .....	1	SB20
2	8215191013	BRACKET, PUMP	1	
3	0017106025	HEX. HEAD BOLT	5	
4	7522054204	BUSHING	1	
5	0131506000	NIPPLE	1	
6	0120006005	VALVE	1	
7	0602022202	HOSE JOINT	1	
8	3972054104	HOSE JOINT	1	
9	3972054304	PACKING	1	
10	0265801650	HOSE	1	
11	0605515074	HOSE BAND	2	
12	0193301200	HOSE	1	
13	0605515004	HOSE BAND	1	

# DCA-400SSK — JACKET WATER HEATER ASSY.

JACKET WATER HEATER ASSY.



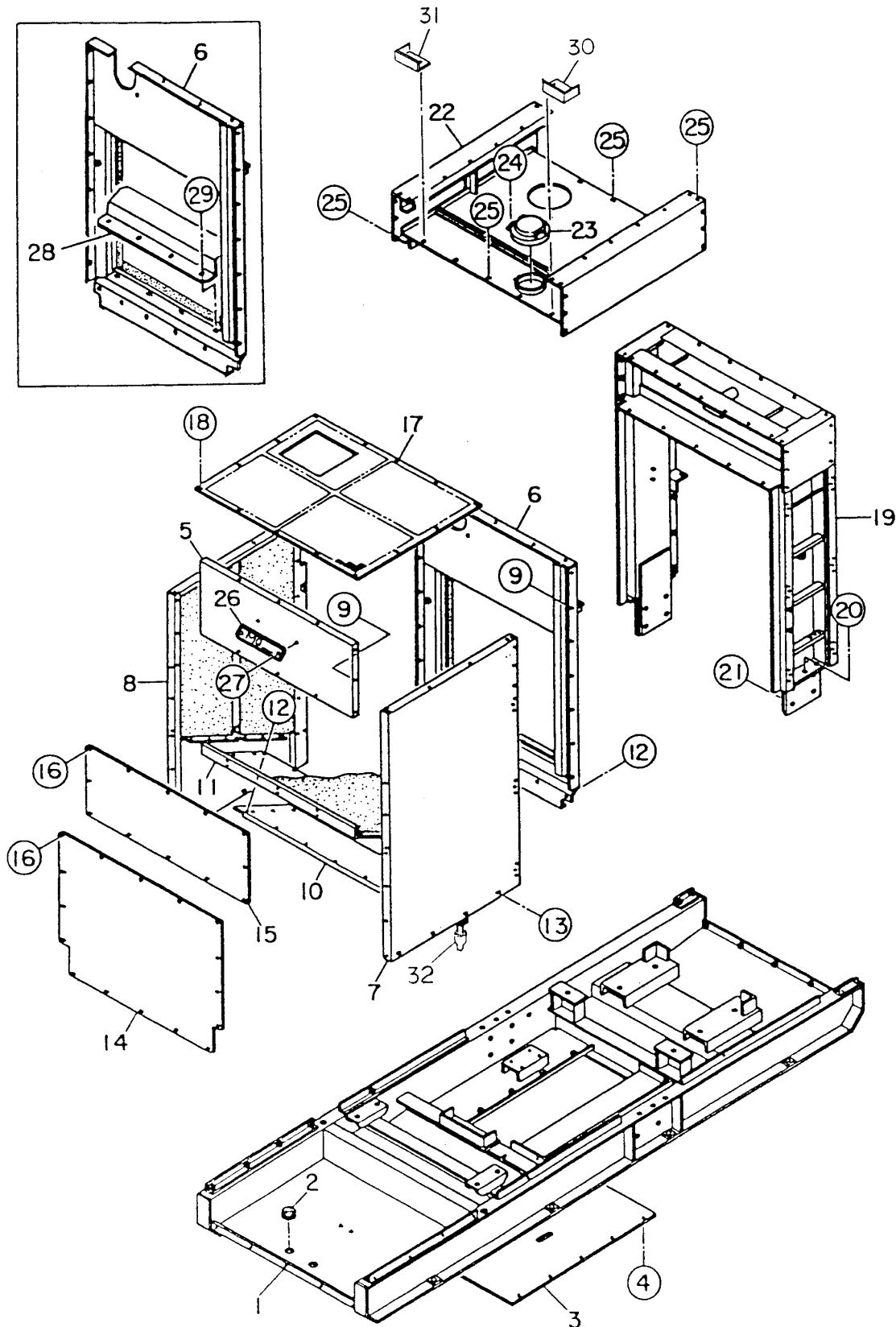
# DCA-400SSK — JACKET WATER HEATER ASSY.

## JACKET WATER HEATER ASSY.

<u>NO</u>	<u>PART NO</u>	<u>PART NAME</u>	<u>QTY.</u>	<u>REMARKS</u>
1	SB120110000	WATER HEATER .....	1 .....	REPLACES 0602014294
2	011206020	HEX. HEAD BOLT .....	4 .....	REPLACES 0017106020
3	0603307690	SOCKET	1	
4	C9202000104	BUSHING	2	
5	0603306912	REDUCING NIPPLE	2	
6	0603306224	STREET ELBOW	2	
7	0603325077	VALVE	2	
8	0602022294	HOSE JOINT	4	
9	C3322700014	HOSE	1	
10	C3322700104	HOSE	1	
11	0605515134	HOSE BAND	4	

# DCA-400SSK — ENCLOSURE ASSY. (PART 1)

## ENCLOSURE ASSY. (PART 1)



# DCA-400SSK — ENCLOSURE ASSY. (PART 1)

## ENCLOSURE ASSY. (PART 1)

<u>NO</u>	<u>PART NO</u>	<u>PART NAME</u>	<u>QTY.</u>	<u>REMARKS</u>
1	C3415000102	BASE	1	
2	0601851733	GROMMET	2	
3	C3414100004	FLOOR PANEL	1	
4	0019208020	HEX. HEAD BOLT	10	
5	C3424001204	FRONT FRAME	1	
	C3494100903	LINING	1	
6	C3425000003	FRONT FRAME	1	
	C3494100903	LINING	1	
7	C3245000102	FRONT FRAME	1	
	C3494100903	LINING	1	
8	C3425000202	FRONT FRAME	1	
	C3494100903	LINING	1	
9	0019208020	HEX. HEAD BOLT	20	
10	C3425300003	GUIDE PANEL, AIR	1	
	C3494100903	LINING	1	
11	C3424300303	GUIDE PANEL, AIR	1	
	C3494100903	LINING	1	
12	0019208020	HEX. HEAD BOLT	24	
13	0019210025	HEX. HEAD BOLT	8	
14	C3425200003	COVER, FRONT FRAME	1	
15	C3424201304	COVER, FRONT FRAME	1	
	C3494101004	LINING	1	
16	0019208020	HEX. HEAD BOLT	28	
	0042308000	LOCK WASHER	28	
	0047008022	PLAIN WASHER	28	
17	C3424201503	COVER, FRONT FRAME	1	
18	0019208020	HEX. HEAD BOLT	14	
	0042308000	LOCK WASHER	14	
	0047008022	PLAIN WASHER	14	
19	C3434000202	CENTER FRAME	1	
20	0010120070	HEX. HEAD BOLT	6	
	0030020000	HEX. NUT	6	
	0040020000	LOCK WASHER	6	
	0041220000	PLAIN WASHER	12	
21	0010120060	HEX. HEAD BOLT	8	

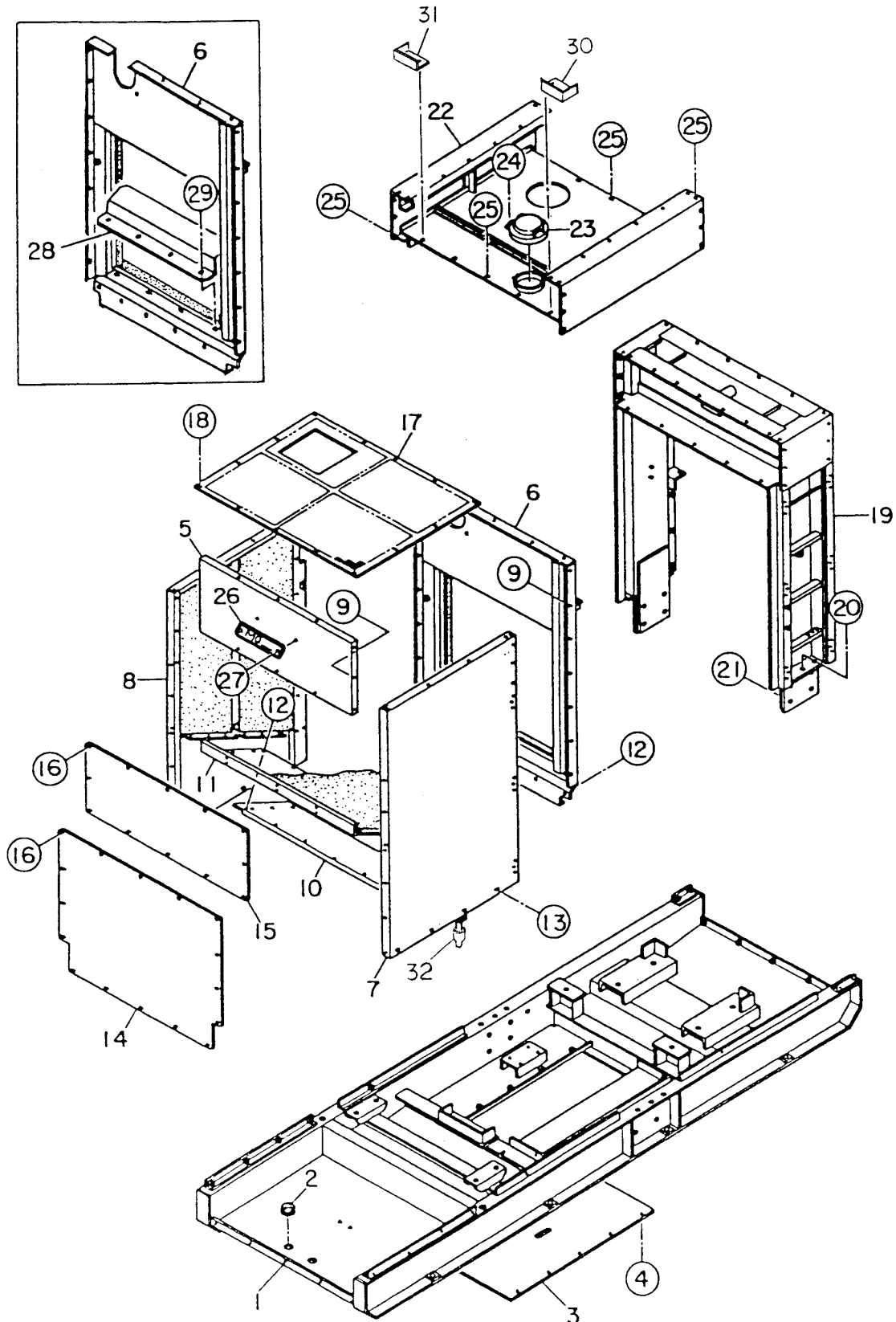
THE PART NUMBER INDICATED ABOVE IS DEFAULTED TO ORANGE. ADD THE FOLLOWING LETTERS AFTER THE PART NUMBER WHEN ORDERING ANY PAINTED PANEL TO INDICATE COLOR OF UNIT:

MQGRN-SUNBELT GREEN

THE SERIAL NUMBER MAY BE REQUIRED.

# DCA-400SSK — ENCLOSURE ASSY. (PART 1)

## ENCLOSURE ASSY. (PART 1)



# DCA-400SSK — ENCLOSURE ASSY. (PART 1)

## ENCLOSURE ASSY. (PART 1)

<u>NO</u>	<u>PART NO</u>	<u>PART NAME</u>	<u>QTY.</u>	<u>REMARKS</u>
	0030020000	HEX. NUT	8	
	0040020000	LOCK WASHER	8	
	0041220000	PLAIN WASHER	16	
22	C3464100102	ROOF PANEL	1	
23	0800251701	FILLER COVER	1	
24	0025006016	MACHINE SCREW	2	
	0042306000	LOCK WASHER	2	
	0042406000	PLAIN WASHER	2	
25	0019208020	HEX. HEAD BOLT	28	
	0042308000	LOCK WASHER	28	
	0047008022	PLAIN WASHER	28	
26	0600500090	EMBLEM	1	
27	0021106016	MACHINE SCREW	2	
28	C3425700104	COVER	1	
29	0019206020	HEX. HEAD BOLT	4	
30	C3465500004	COVER (LEFT)	1	
31	C3465500104	COVER (RIGHT)	1	
32	C9311400104	DRAIN PIPE .....	2	..... S/N3703369~

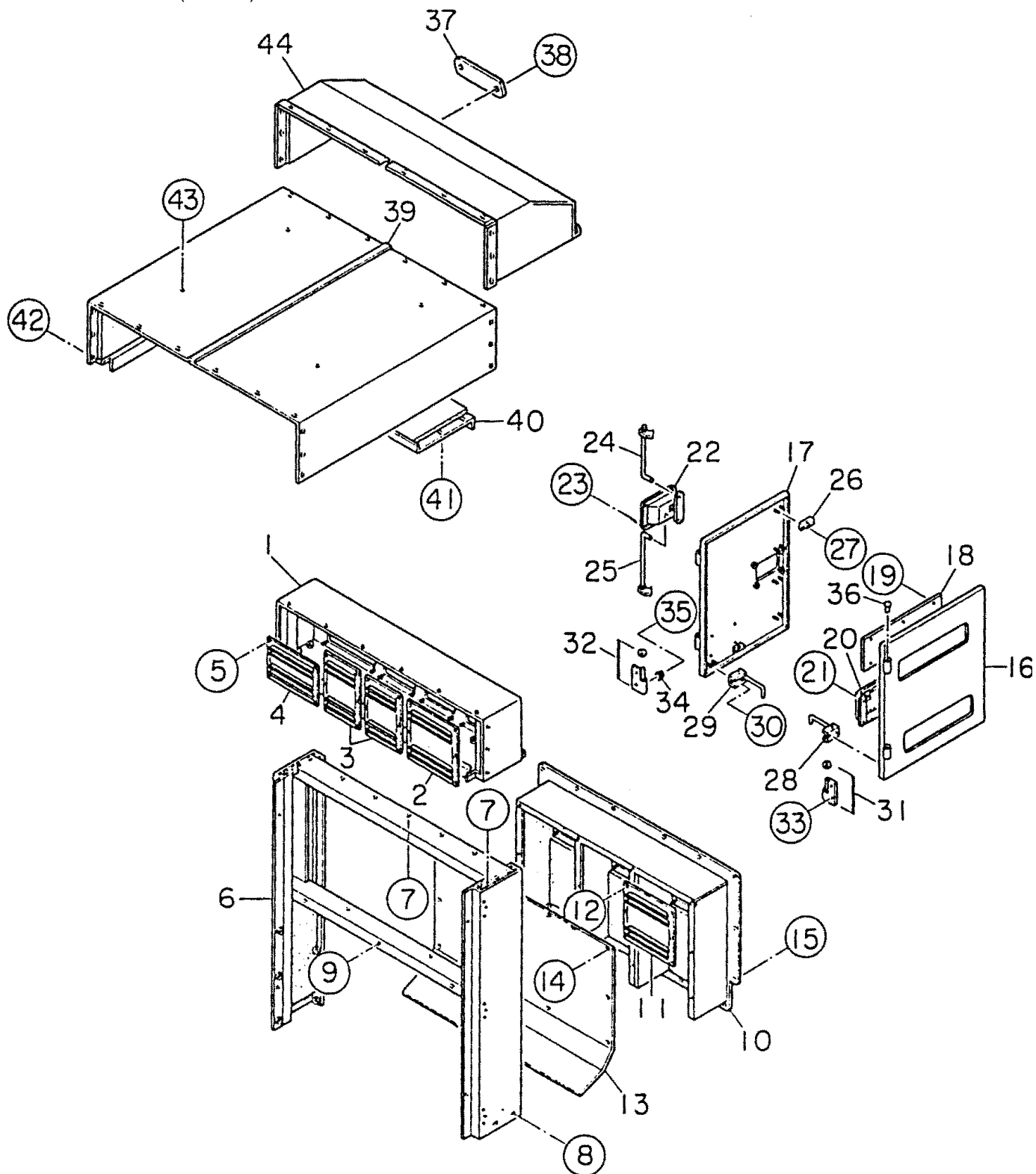
THE PART NUMBER INDICATED ABOVE IS DEFAULTED TO ORANGE. ADD THE FOLLOWING LETTERS AFTER THE PART NUMBER WHEN ORDERING ANY PAINTED PANEL TO INDICATE COLOR OF UNIT:

MQGRN-SUNBELT GREEN

THE SERIAL NUMBER MAY BE REQUIRED.

# DCA-400SSK — ENCLOSURE ASSY. (PART 2)

ENCLOSURE ASSY. (PART 2)



# DCA-400SSK — ENCLOSURE ASSY. (PART 2)

## ENCLOSURE ASSY. (PART 2)

<u>NO</u>	<u>PART NO</u>	<u>PART NAME</u>	<u>QTY.</u>	<u>REMARKS</u>
1	C3444000903	REAR FRAME	1	
2	8195151204	LOUVER PANEL	1	
3	C3454700104	LOUVER PANEL	2	
4	8175151204	LOUVER PANEL	1	
5	0207006000	HEX. NUT	22	
6	C3444000402	REAR FRAME	1	
	8225940104	LINING	1	
7	0017108020	HEX. HEAD BOLT	11	
8	0019210025	HEX. HEAD BOLT	4	
9	0017110025	HEX. HEAD BOLT	3	
10	C3445300003	COVER, REAR FRAME	1	
	C3494300604	LINING	1	
11	8195151004	LOUVER PANEL	3	
12	0207006000	HEX. NUT	18	
13	C3444300804	DUCT COVER	1	
	C3494300704	LINING	1	
14	0017108020	HEX. HEAD BOLT	12	
15	0019208020	HEX. HEAD BOLT	15	
	0042308000	LOCK WASHER	15	
	0047008022	PLAIN WASHER	15	
16	C3444200503	DOOR, REAR FRAME	1	
17	C3444200903	DOOR, REAR FRAME	1	
18	8225147004	WINDOW PLATE	2	
19	0037906000	HEX. NUT	12	
20	B9114500104	DOOR POCKET	1	
21	0207006000	HEX. NUT	4	
22	B9114000102	DOOR HANDLE	1	
23	0021806016	MACHINE SCREW	4	
	0030006000	HEX. NUT	4	
24	8225146204	DOOR ROD	1	
25	8225146304	DOOR ROD	1	
26	0845050704	STAY	4	
27	0207006000	HEX. NUT	8	
28	0805011304	STOPPER, DOOR	1	
29	0805011204	STOPPER, DOOR	1	

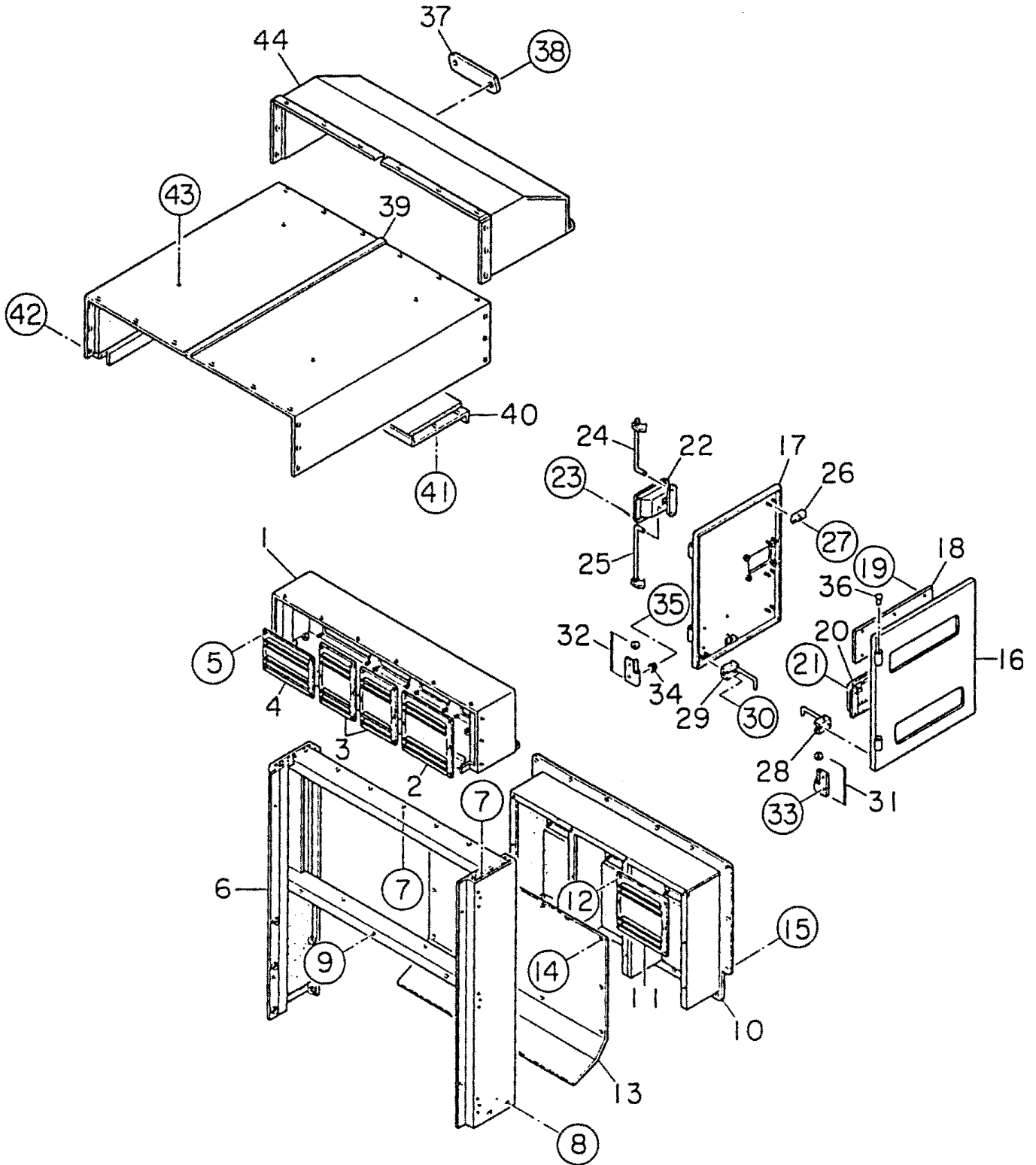
THE PART NUMBER INDICATED ABOVE IS DEFAULTED TO ORANGE. ADD THE FOLLOWING LETTERS AFTER THE PART NUMBER WHEN ORDERING ANY PAINTED PANEL TO INDICATE COLOR OF UNIT:

MQGRN-SUNBELT GREEN

THE SERIAL NUMBER MAY BE REQUIRED.

# DCA-400SSK — ENCLOSURE ASSY. (PART 2)

## ENCLOSURE ASSY. (PART 2)



# DCA-400SSK — ENCLOSURE ASSY. (PART 2)

## ENCLOSURE ASSY. (PART 2)

<u>NO</u>	<u>PART NO</u>	<u>PART NAME</u>	<u>QTY.</u>	<u>REMARKS</u>
30	0207006000	HEX. NUT	4	
31	M9110100204	HINGE .....	2	REPLACES 0845047104
	0845045004	WASHER	2	
32	0845047204	HINGE	2	
	0845045004	WASHER	2	
33	0019208020	HEX. HEAD BOLT	6	
34	0601850097	STOPPER	2	
35	0021008025	MACHINE SCREW	2	
36	0845031504	CAP	4	
37	0600500090	EMBLEM	1	
38	0021106016	MACHINE SCREW	2	
39	C3464200102	ROOF PANEL	1	
	C3494500204	LINING	1	
40	C3464500304	COVER, ROOF PANEL	1	
	C3494500304	LINING	1	
41	0017108020	HEX. HEAD BOLT	9	
42	0019208020	HEX. HEAD BOLT	24	
	0042308000	LOCK WASHER	24	
	0047008020	PLAIN WASHER	24	
43	0019210025	HEX. HEAD BOLT	4	
44	C3445500003	VISOR	1	

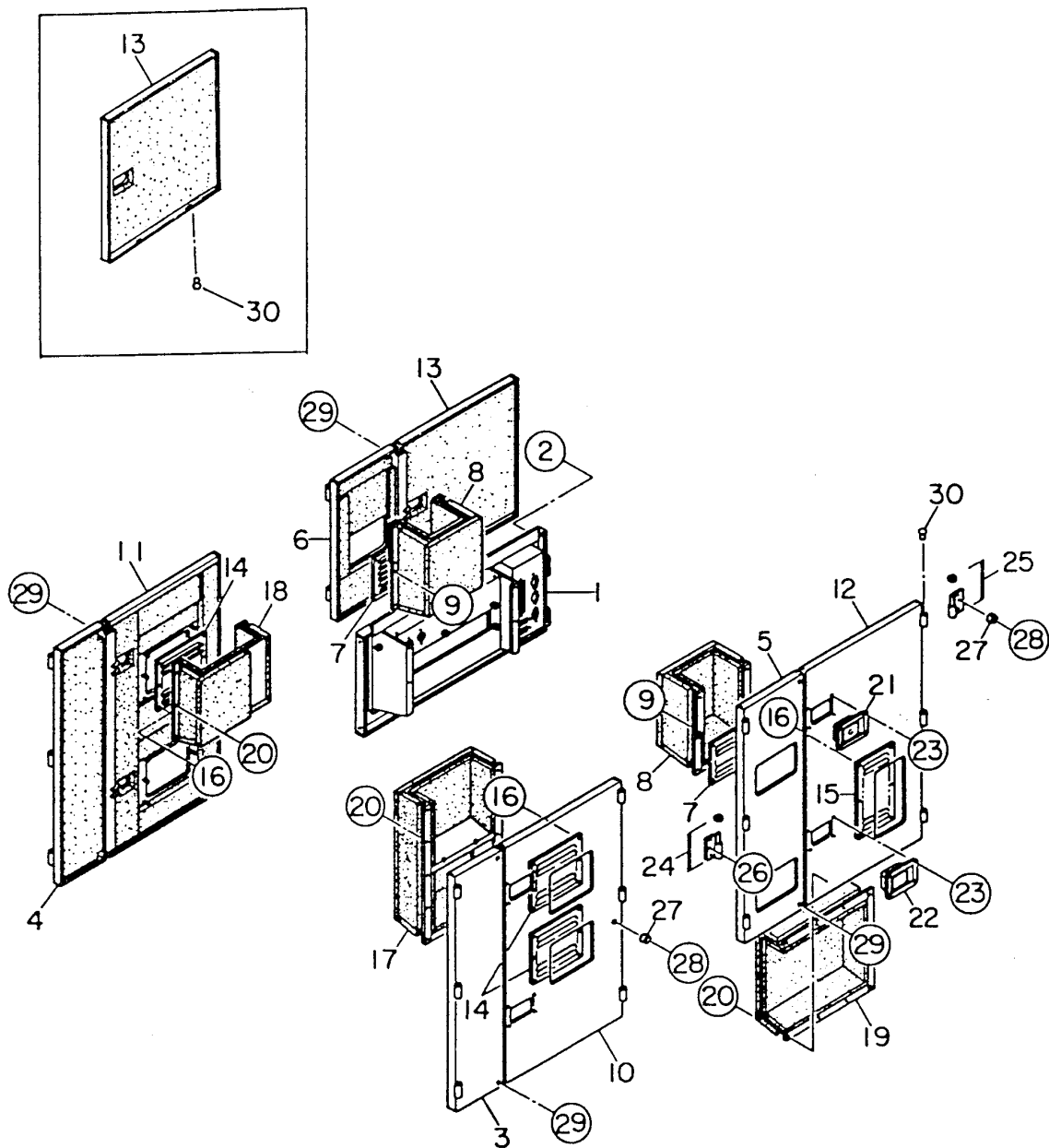
THE PART NUMBER INDICATED ABOVE IS DEFAULTED TO ORANGE. ADD THE FOLLOWING LETTERS AFTER THE PART NUMBER WHEN ORDERING ANY PAINTED PANEL TO INDICATE COLOR OF UNIT:

MQGRN-SUNBELT GREEN

THE SERIAL NUMBER MAY BE REQUIRED.

# DCA-400SSK — ENCLOSURE ASSY. (PART 3)

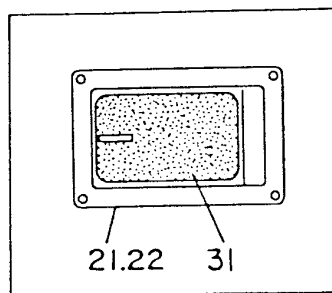
## ENCLOSURE ASSY. (PART 3)



THE PART NUMBER INDICATED ABOVE IS DEFAULTED TO ORANGE. ADD THE FOLLOWING LETTERS AFTER THE PART NUMBER WHEN ORDERING ANY PAINTED PANEL TO INDICATE COLOR OF UNIT:

MQGRN-SUNBELT GREEN

THE SERIAL NUMBER MAY BE REQUIRED.



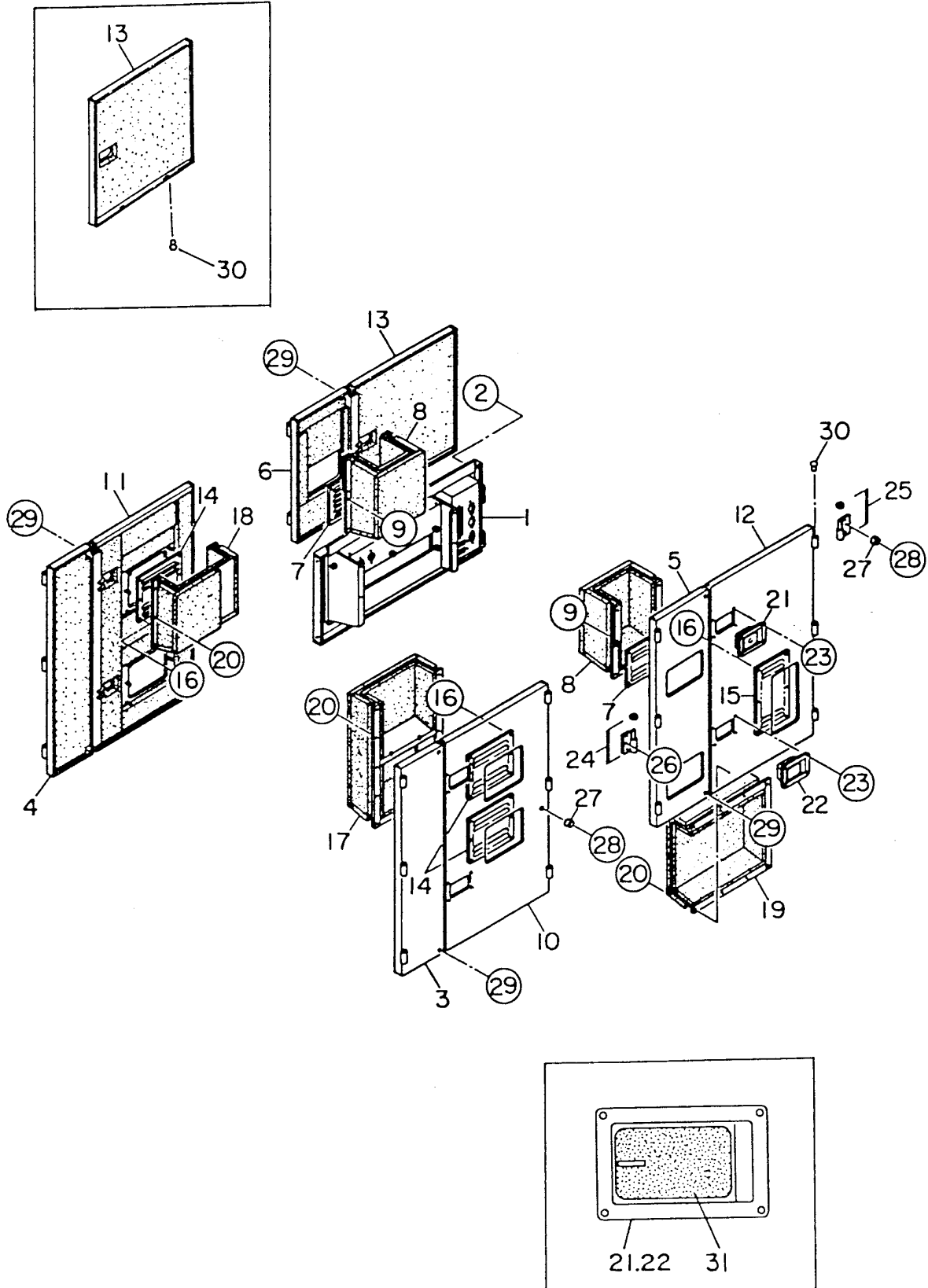
# DCA-400SSK — ENCLOSURE ASSY. (PART 3)

## ENCLOSURE ASSY. (PART 3)

<u>NO</u>	<u>PART NO</u>	<u>PART NAME</u>	<u>QTY.</u>	<u>REMARKS</u>
1	C3454201042	SPLASHER PANEL .....	1	UP TO S/N3703368
1	C3454202002	SPLASHER PANEL .....	1	S/N3703369~
2	0019108065	HEX. HEAD BOLT	6	
	0042308000	LOCK WASHER	6	
	0042408000	PLAIN WASHER	6	
3	C3454101203	SIDE PANEL	1	
	C3494404704	LINING	1	
	0226900320	EDGE COVER	2	
4	C3455100303	SIDE PANEL	1	
	C3494404704	LINING	1	
	0226900320	EDGE COVER	2	
5	C3455100003	SIDE PANEL	1	
	C3494406304	LINING	1	
	0226900320	EDGE COVER	2	
6	C3455100103	SIDE PANEL	1	
	C3494402204	LINING	1	
	0226900320	EDGE COVER	2	
7	C3454700504	LOUVER PANEL	3	
8	C3454301004	DUCT	3	
	C3494404804	LINING	3	
9	0207006000	HEX. NUT	27	
10	C3455000103	SIDE DOOR	1	
	C3494406604	LINING	1	
11	C3455000203	SIDE DOOR	1	
	C3494406404	LINING	1	
12	C3455000303	SIDE DOOR	1	
	C3494404504	LINING	1	
13	C3455000403	SIDE DOOR	1	
	C3494402704	LINING	1	
14	8195151004	LOUVER PANEL	4	
15	8215151004	LOUVER PANEL	1	
16	0207006000	HEX. NUT	30	
17	C3454301403	DUCT	1	
	C3494406704	LINING	1	
18	C3454301304	DUCT	2	
	C3494406504	LINING	2	
19	C3454300904	DUCT	1	
	C3494404604	LINING	1	
20	0207006000	HEX. NUT	35	
21	B9114000002	DOOR HANDLE	4	
22	0825007362	DOOR HANDLE	3	
23	0021806016	MACHINE SCREW	28	
	0030006000	HEX. NUT	28	
24	0845046904	HINGE	11	
	0845045004	WASHER	11	

# DCA-400SSK — ENCLOSURE ASSY. (PART 3)

## ENCLOSURE ASSY. (PART 3)



# DCA-400SSK — ENCLOSURE ASSY. (PART 3)

## ENCLOSURE ASSY. (PART 3)

<u>NO</u>	<u>PART NO</u>	<u>PART NAME</u>	<u>QTY.</u>	<u>REMARKS</u>
25	0845047004	HINGE	11	
	0845045004	WASHER	11	
26	0019208020	HEX. HEAD BOLT	57	
27	0601850097	STOPPER	10	
28	0021008025	MACHINE SCREW	10	
29	0019108065	HEX. HEAD BOLT	8	
	0042308000	LOCK WASHER	8	
	0042408022	PLAIN WASHER	8	
30	0845031504	CAP	32	
31	C9312500004	RUBBER SEAL	7	

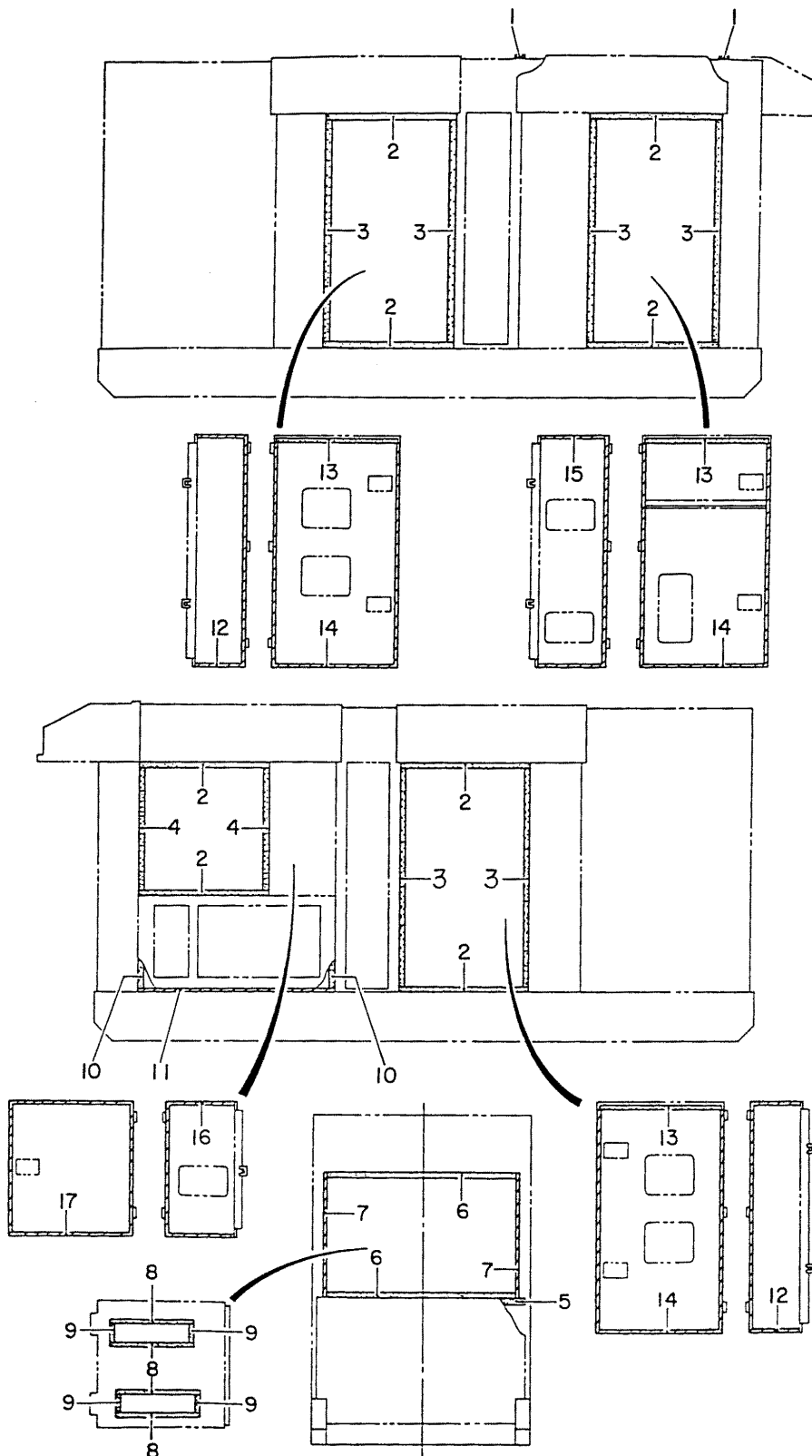
THE PART NUMBER INDICATED ABOVE IS DEFAULTED TO ORANGE. ADD THE FOLLOWING LETTERS AFTER THE PART NUMBER WHEN ORDERING ANY PAINTED PANEL TO INDICATE COLOR OF UNIT:

MQGRN-SUNBELT GREEN

THE SERIAL NUMBER MAY BE REQUIRED.

# DCA-400SSK — ENCLOSURE ASSY. (RUBBER SEALS)

## RUBBER SEALS ASSY.



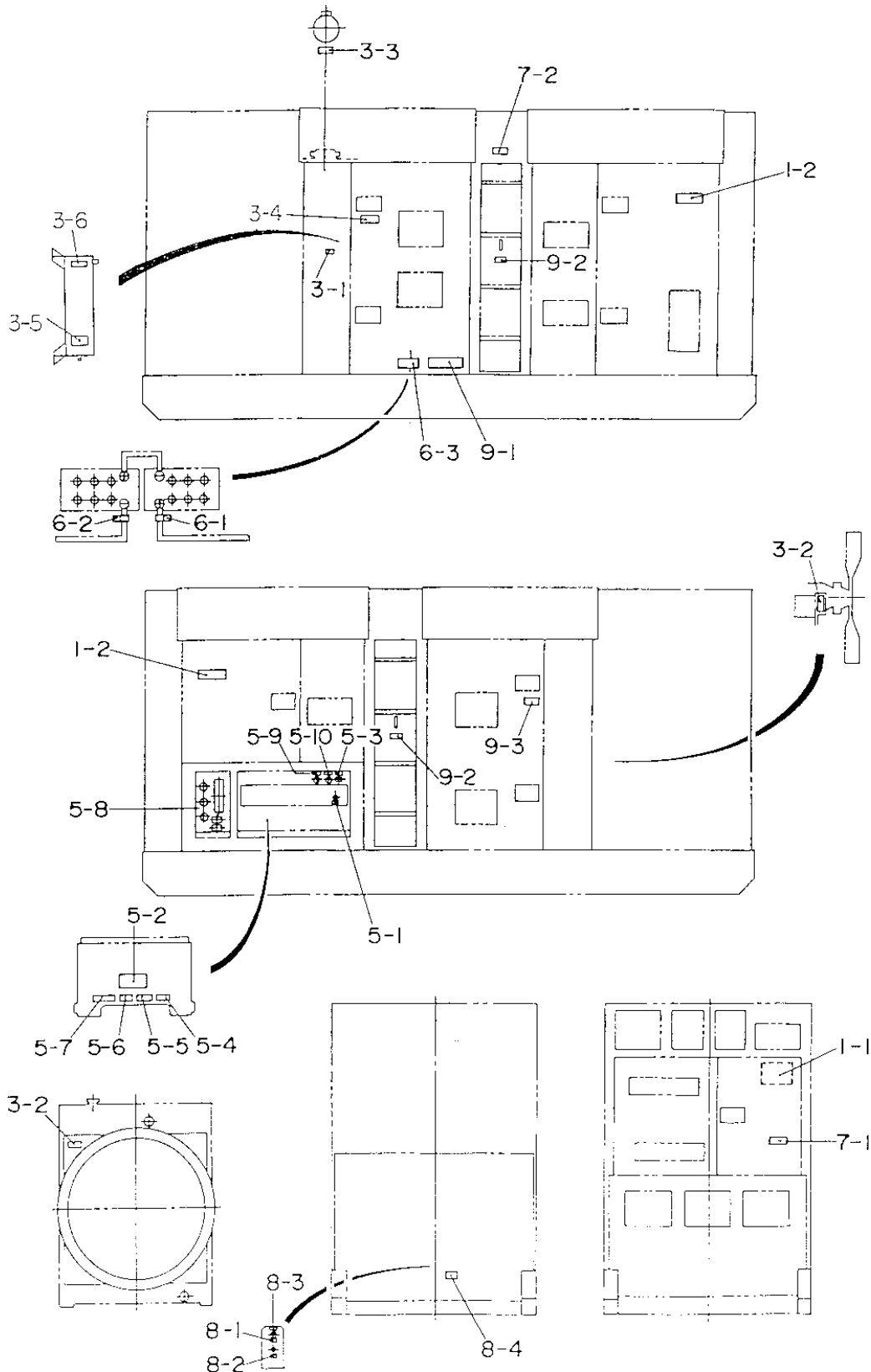
# DCA-400SSK — ENCLOSURE ASSY. (RUBBER SEALS)

## RUBBER SEALS ASSY.

<u>NO</u>	<u>PART NO</u>	<u>PART NAME</u>	<u>QTY.</u>	<u>REMARKS</u>
1	0228901390	RUBBER SEAL	6	
2	0228900825	RUBBER SEAL	8	
3	0228900790	RUBBER SEAL	2	
4	0229201400	RUBBER SEAL	2	
5	0228800795	RUBBER SEAL	2	
6	0228801240	RUBBER SEAL	1	
7	0229201340	RUBBER SEAL	1	
8	0228100120	RUBBER SEAL	4	
9	0228100510	RUBBER SEAL	4	
10	0228901450	RUBBER SEAL	3	
11	0229200435	RUBBER SEAL	4	
12	0229200325	RUBBER SEAL	4	
13	0228900850	RUBBER SEAL	1	
14	0229200600	RUBBER SEAL	2	
15	0229201250	RUBBER SEAL	1	

# DCA-400SSK — NAME PLATE AND DECALS

## NAME PLATE AND DECALS



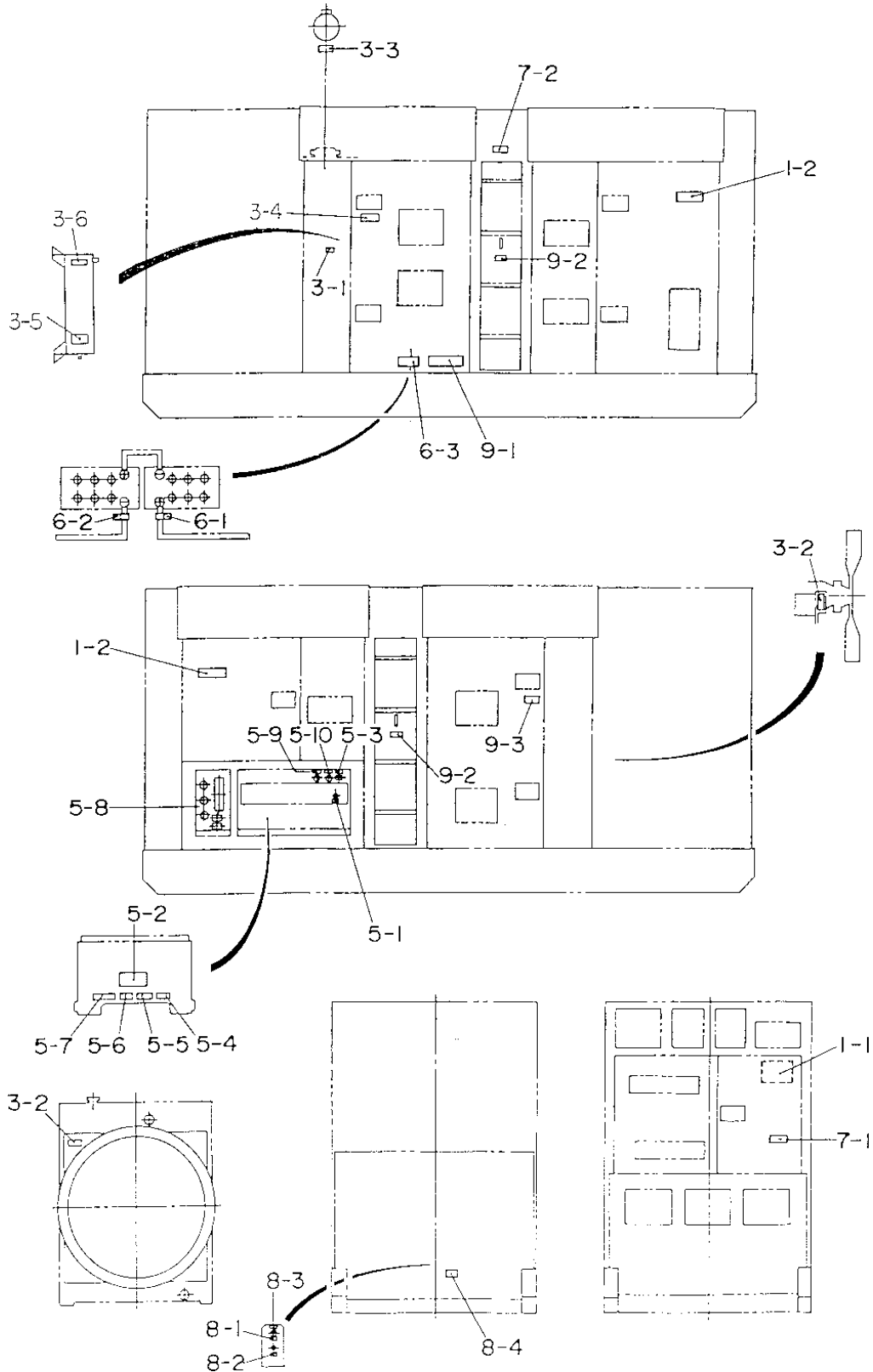
# DCA-400SSK — NAME PLATE AND DECALS

## NAME PLATE AND DECALS

<u>NO</u>	<u>PART NO</u>	<u>PART NAME</u>	<u>QTY.</u>	<u>REMARKS</u>
1-1	C1552000403	DECAL; HANDLING PROCEDURES .....	1 .....	C15200040
1-2	B1552000103	DECAL; CAUTION .....	2 .....	B15200010
<b>CONTROL BOX GROUP</b>				
2-1	0800520100	DECAL; ON-OFF .....	1 .....	AT202
2-2	0800520904	PLATE; AMMETER CHANGE-OVER SWITCH .....	1 .....	N2438
2-3	0800520814	PLATE; VOLTMETER CHANGE-OVER SWITCH .....	1 .....	N2439
2-4	0840624504	DECAL; CIRCUIT BREAKER .....	1 .....	S3031
2-5	0840624604	DECAL; PANEL LIGHT SWITCH .....	1 .....	S3032
2-6	0840624704	DECAL; PILOT LAMP .....	1 .....	S3033
2-7	0840624804	DECAL; VOLTAGE REGULATOR .....	1 .....	S3034
2-8	B9531100604	DECAL; WARNING ELECTRIC SHOCK HAZARD .....	1 .....	B93110060
2-9	C0551000903	DECAL; SETTING FOR OUTPUT VOLTAGE .....	1 .....	C05100090
2-10	C2551000004	DECAL; SAFETY INSTRUCTION .....	1 .....	C25100000
2-11	C3561101103	DECAL; WHISPERWATT 400 .....	1 .....	C36110110
2-12	C9502400004	DECAL; HIGH IDLE SPEED .....	1 .....	C90240000
<b>ENGINE &amp; RADIATOR GROUP</b>				
3-1	6360610304	DECAL; WATER .....	1 .....	S1880
3-2	B9504000404	DECAL; WARNING MOVING PARTS .....	2 .....	B90400040
3-3	B9504100104	DECAL; WARNING HOT COOLANT .....	1 .....	B90410010
3-4	C9542200004	DECAL; BLOW-BY OIL MIST DRAIN DAILY .....	1 .....	C94220000
3-5	C9542200104	DECAL; BLOW-BY OIL MIST TANK .....	1 .....	C94220010
3-6	C9542200204	DECAL; INLET .....	1 .....	C94220020
<b>ENGINE OPERATING PANEL GROUP</b>				
4-1	C0551000504	DECAL; BATTERY SWITCH .....	1 .....	C05100050
4-2	C1552000013	DECAL; OPERATING PANEL .....	1 .....	C15200001
4-3	C1552000104	DECAL; FUEL LEAK DETECTED .....	1 .....	C15200010
<b>OUTPUT TERMINAL GROUP</b>				
5-1	0840614104	DECAL; GROUND .....	1 .....	S2635
5-2	0840619904	DECAL; DANGER HIGH VOLTAGE .....	1 .....	S2731
5-3	9039209064	DECAL; START CONTACT .....	1 .....	S4468
5-4	B9511100304	DECAL; WARNING .....	1 .....	B91110030
5-5	B9511100404	DECAL; WARNING ELECTRIC SHOCK HAZARD .....	1 .....	B91110040
5-6	B9531100504	DECAL; WARNING ELECTRIC SHOCK HAZARD .....	1 .....	B93110050
5-7	C0551000404	DECAL; 3-PHASE OUTPUT TERMINAL .....	1 .....	C05100040
5-8	C0551001503	DECAL; RECEPTACLE & CIRCUIT BREAKER .....	1 .....	UP TO S/N3703368;C05100150
	C1551000803	DECAL; RECEPTACLE & CIRCUIT BREAKER .....	1 .....	S/N3703369~;C15100080
5-9	C1552000204	DECAL; WATER HEATER .....	1 .....	C15200020
5-10	C1552000304	DECAL; BATTERY CHARGER .....	1 .....	C15200030

# DCA-400SSK — NAME PLATE AND DECALS

## NAME PLATE AND DECALS



# DCA-400SSK — NAME PLATE AND DECALS

## NAME PLATE AND DECALS

<u>NO</u>	<u>PART NO</u>	<u>PART NAME</u>	<u>QTY.</u>	<u>REMARKS</u>
<b>BATTERY GROUP</b>				
6-1	0800689404	DECAL; + .....	1 .....	S2090
6-2	0800689504	DECAL; - .....	1 .....	S2091
6-3	C9505300004	DECAL; CAUTION .....	1 .....	C90530000
<b>MUFFLER GROUP</b>				
7-1	B9504200004	DECAL; WARNING ENGINE EXHAUST .....	1 .....	B90420000
7-2	B9511100204	DECAL; CAUTION HOT SURFACES .....	1 .....	B91110020
<b>FUEL PIPING GROUP</b>				
8-1	0800688404	DECAL; FUEL INLET .....	1 .....	S1344
8-2	0800688504	DECAL; FUEL OUTLET .....	1 .....	S1345
8-3	1320620904	DECAL; DIESEL FUEL .....	1 .....	S1756
8-4	B9504500004	DECAL; WARNING DIESEL FUEL .....	1 .....	B90450000
<b>ENCLOSURE GROUP</b>				
9-1	1320610603	DECAL; WATER-OIL .....	1 .....	S1760
9-2	1320610603	DECAL; SUPPORT HOOK .....	2 .....	S2257
9-3	B9504000304	DECAL; CAUTION HOT PARTS .....	1 .....	B90400030

**PAYMENT TERMS**

Terms of payment for parts are net 10 days.

**FREIGHT POLICY**

All parts orders will be shipped collect or prepaid with the charges added to the invoice. All shipments are F.O.B. point of origin. Multiquip's responsibility ceases when a signed manifest has been obtained from the carrier, and any claim for shortage or damage must be settled between the consignee and the carrier.

**MINIMUM ORDER**

The minimum charge for orders from Multiquip is \$15.00 net. Customers will be asked for instructions regarding handling of orders not meeting this requirement.

**RETURNED GOODS POLICY**

Return shipments will be accepted and credit will be allowed, subject to the following provisions:

1. A Returned Material Authorization must be approved by Multiquip prior to shipment.
2. To obtain a Return Material Authorization, a list must be provided to Multiquip Parts Sales that defines item numbers, quantities, and descriptions of the items to be returned.
  - a. The parts numbers and descriptions must match the current parts price list.
  - b. The list must be typed or computer generated.
  - c. The list must state the reason(s) for the return.
  - d. The list must reference the sales order(s) or invoice(s) under which the items were originally purchased.
  - e. The list must include the name and phone number of the person requesting the RMA.
3. A copy of the Return Material Authorization must accompany the return shipment.
4. Freight is at the sender's expense. All parts must be returned freight prepaid to Multiquip's designated receiving point.
5. Parts must be in new and resalable condition, in the original Multiquip package (if any), and with Multiquip part numbers clearly marked.
6. The following items are not returnable:
  - a. Obsolete parts. (If an item is listed in the parts price book as being replaced by another item, it is obsolete.)
  - b. Any parts with a limited shelf life (such as gaskets, seals, "O" rings, and other rubber parts) that were purchased more than six months prior to the return date.
  - c. Any line item with an extended dealer net price of less than \$5.00.
  - d. Special order items.
  - e. Electrical components.
  - f. Paint, chemicals, and lubricants.
  - g. Decals and paper products.
  - h. Items purchased in kits.
7. The sender will be notified of any material received that is not acceptable.
8. Such material will be held for 5 working days from notification, pending instructions. If a reply is not received within 5 days, the material will be returned to the sender at his expense.
9. Credit on returned parts will be issued at dealer net price at time of the original purchase, less a 15% restocking charge.
10. In cases where an item is accepted for which the original purchase document can not be determined, the price will be based on the list price that was effective twelve months prior to the RMA date.
11. Credit issued will be applied to future purchases only.

**PRICING AND REBATES**

Prices are subject to change without prior notice. Price changes are effective on a specific date and all orders received on or after that date will be billed at the revised price. Rebates for price declines and added charges for price increases will not be made for stock on hand at the time of any price change.

Multiquip reserves the right to quote and sell direct to Government agencies, and to Original Equipment Manufacturer accounts who use our products as integral parts of their own products.

**SPECIAL EXPEDITING SERVICE**

A \$20.00 to \$50.00 surcharge will be added to the invoice for special handling including bus shipments, insured parcel post or in cases where Multiquip must personally deliver the parts to the carrier.

**LIMITATIONS OF SELLER'S LIABILITY**

Multiquip shall not be liable here under for damages in excess of the purchase price of the item with respect to which damages are claimed, and in no event shall Multiquip be liable for loss of profit or good will or for any other special, consequential or incidental damages.

**LIMITATION OF WARRANTIES**

No warranties, express or implied, are made in connection with the sale of parts or trade accessories nor as to any engine not manufactured by Multiquip. Such warranties made in connection with the sale of new, complete units are made exclusively by a statement of warranty packaged with such units, and Multiquip neither assumes nor authorizes any person to assume for it any other obligation or liability whatever in connection with the sale of its products. A part from such written statement of warranty, there are no warranties, express, implied or statutory, which extend beyond the description of the products on the face hereof.



# PARTS AND OPERATION MANUAL

## **HERE'S HOW TO GET HELP**

*PLEASE HAVE THE MODEL AND SERIAL NUMBER  
ON-HAND WHEN CALLING*

### **PARTS DEPARTMENT**

*800/427-1244 or 310/537-3700*

*FAX: 800/672-7877 or 310/637-3284*

### **SERVICE DEPARTMENT**

*800/835-2551 or 310/537-3700*

*FAX: 310/638-8046*

### **WARRANTY DEPARTMENT**

*800/835-2551 or 310/537-3700*

*FAX: 310/638-8046*

### **MAIN**

*800/421-1244 or 310/537-3700*

*FAX: 310/537-3927*

Manufactured for Multiquip Inc.  
by  
DENYO MANUFACTURING CO., USA



**MULTIQUIP INC.**  
POST OFFICE BOX 6254  
CARSON, CA 90749  
310-537-3700 • 800-421-1244  
FAX: 310-537-3927  
E-MAIL: [mq@multiquip.com](mailto:mq@multiquip.com)  
WWW: [multiquip.com](http://multiquip.com)

Atlanta • Boise • Dallas • Houston • Newark  
Quebec, Canada • Manchester, UK • Rio De Janeiro, BR • Guadalajara, MX