



# Cutler-Hammer

## O & M Manual for the ATC-100 Contactor Based Transfer Switch

Instructional Booklet

### New Information

<i>Description</i>	<i>Page</i>
1. Introduction . . . . .	2
2. Receiving, Handling, and Storing. . . . .	5
3. Equipment Description . . . . .	5
4. Installation and Wiring . . . . .	9
5. Operation. . . . .	13
6. Testing and Problem solving. . . . .	14
7. Adjustments. . . . .	16
8. Maintenance. . . . .	16
9. Renewal Parts Guide . . . . .	17
10. ATC-100 Contactor Based ATS Quick Start Instructions	18
11. Appendix A: Pickup / Dropout Tables. . . . .	25



**⚠ WARNING**

READ AND UNDERSTAND THE INSTRUCTIONS CONTAINED HEREIN AFTER BEFORE ATTEMPTING TO UNPACK, ASSEMBLE, OPERATE, OR MAINTAIN THIS EQUIPMENT.

HAZARDOUS VOLTAGES ARE PRESENT INSIDE TRANSFER SWITCH ENCLOSURES THAT CAN CAUSE DEATH OR SEVERE PERSONAL INJURY. FOLLOW PROPER INSTALLATION, OPERATION, AND MAINTENANCE PROCEDURES TO AVOID THESE VOLTAGES.

TRANSFER SWITCH EQUIPMENT COVERED BY THIS INSTRUCTION BOOK IS DESIGNED AND TESTED TO OPERATE WITHIN ITS NAMEPLATE RATINGS. OPERATION OUTSIDE OF THESE RATINGS MAY CAUSE THE EQUIPMENT TO FAIL RESULTING IN DEATH, SERIOUS BODILY INJURY, AND/OR PROPERTY DAMAGE. ALL RESPONSIBLE PERSONNEL SHOULD LOCATE THE DOOR MOUNTED EQUIPMENT NAMEPLATE AND BE FAMILIAR WITH THE INFORMATION PROVIDED ON THE NAMEPLATE. A TYPICAL EQUIPMENT NAMEPLATE IS SHOWN IN FIGURE 1

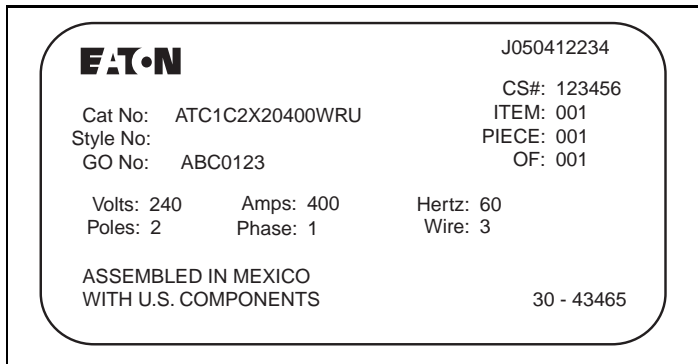

Figure 1. Typical Automatic Transfer Switch (ATS) Equipment Nameplate.

All possible contingencies that may arise during installation, operation, or maintenance, and all details and variations of this equipment do no purport to be covered by these instructions. If further information is desired by the purchaser regarding a particular installation, operation, or maintenance of particular equipment, please contact an authorized Eaton Sales Representative or the installing contractor.

**SECTION 1: INTRODUCTION**

**1.1 Preliminary Comments and Safety Precautions**

This technical document is intended to cover most aspects associated with the installation, application, operation, and maintenance of the Automatic Transfer Controller (ATC-100) controlled contactor based ATS with 400 Amperes (A) rating. It is provided as a guide for authorized and qualified personnel only. Please refer to the specific WARNING and CAUTION in Section 1.1.2 before proceeding. If further information is required by the purchaser regarding a particular installation, application, or maintenance activity, please contact an authorized Eaton sales representative or the installing contractor.

**1.1.1 Warranty and Liability Information**

No warranties, expressed or implied, including warranties of fitness for a particular purpose of merchantability, or warranties arising from course of dealing or usage of trade, are made regarding the information, recommendations and descriptions contained herein. In no event will Eaton be responsible to the purchaser or user in contract, in tort (including negligence), strict liability or otherwise for any special, indirect, incidental or consequential damage or loss whatsoever, including but not limited to damage or loss of use of equipment, plant or power system, cost of capital, loss of power, additional expenses in the use of existing power facilities, or claims against the purchaser or user by its customers resulting from the use of the information and descriptions contained herein.

**1.1.2 Safety Precautions**

All safety codes, safety standards, and/or regulations must be strictly observed in the installation, operation, and maintenance of this device.

**⚠ WARNING**

THE WARNINGS AND CAUTIONS INCLUDED AS PART OF THE PROCEDURAL STEPS IN THIS DOCUMENT ARE FOR PERSONAL SAFETY AND PROTECTION OF EQUIPMENT FROM DAMAGE. AN EXAMPLE OF A TYPICAL WARNING LABEL HEADING IS SHOWN ABOVE TO FAMILIARIZE PERSONNEL WITH THE STYLE OF PRESENTATION. THIS WILL HELP TO INSURE THAT PERSONNEL ARE ALERT TO WARNINGS, WHICH APPEAR THROUGHOUT THE DOCUMENT. IN ADDITION, WARNINGS AND CAUTIONS ARE ALL UPPER CASE AND BOLDFACE.

**⚠ CAUTION**

COMPLETELY READ AND UNDERSTAND THE MATERIAL PRESENTED IN THIS DOCUMENT BEFORE ATTEMPTING INSTALLATION, OPERATION, OR APPLICATION OF THE EQUIPMENT. IN ADDITION, ONLY QUALIFIED PERSONS SHOULD BE PERMITTED TO PERFORM ANY WORK ASSOCIATED WITH THIS EQUIPMENT. ANY WIRING INSTRUCTIONS PRESENTED IN THIS DOCUMENT MUST BE FOLLOWED PRECISELY. FAILURE TO DO SO COULD CAUSE PERMANENT EQUIPMENT DAMAGE.

**1.2 General Information**

Transfer switches are used to protect critical electrical loads against loss of power. The load's Utility power source is backed up by a Generator power source. A transfer switch is connected to both the Utility and the Generator power sources and supplies the load with power from one of the two sources. In the event that power is lost from the Utility, the transfer switch transfers the load to the Generator power source. This transfer is automatic. Once Utility power is restored, the load is automatically transferred back to the Utility power source (Figure 2).

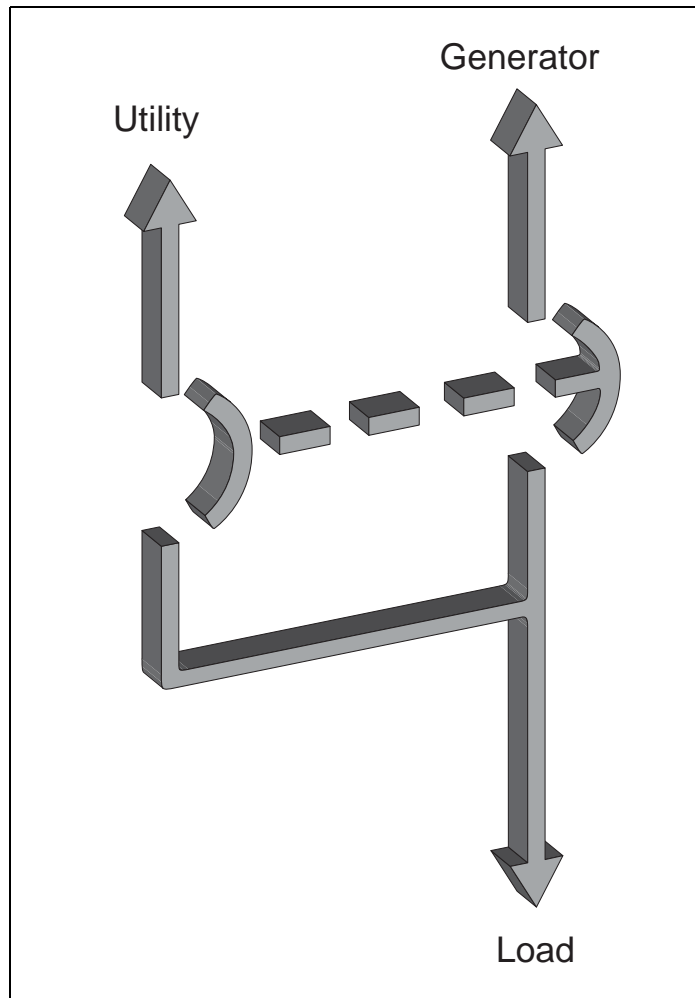

**Figure 2. Typical Load Transfer Switch Schematic (Contactor Type).**

In ATS equipment, the switch's intelligence system initiates the transfer when the Utility power fails or falls below a preset voltage. If the Generator power source is a standby generator, the ATS initiates generator startup and transfers to the Generator power source when sufficient generator voltage is available. When the Utility power is restored, the ATS automatically transfers back and initiates generator shutdown. In the event the Utility power source fails and the Generator power source does not appear, the ATS remains connected to the Utility power source until the Generator power source does appear. Conversely, if connected to the Generator power source and the Generator power source fails while the Utility power source is still unavailable, the ATS remains connected to the Generator power source.

ATSs automatically perform the transfer function and include three basic elements:

1. A power contactor to connect and disconnect the load to and from either power source.
2. Solenoids to make the transfer of the main contacts from source to source.
3. Intelligence/supervisory circuits to constantly monitor the condition of the power sources and thus provide the intelligence necessary for the switch and related circuit operation.

**1.2.1 Design Configuration**

The Eaton contactor based ATS is a compact design that uses a power contactor to transfer essential loads from one power source to another (Figure 3 [400 A]).

The ATS contains suitable mechanical and electrical interlock switches to eliminate the possibility of connecting the utility service to the generator output. In addition, a manual override lever is provided for the transfer function.

**⚠ WARNING**

**DO NOT MANUALLY TRANSFER THE SWITCH WHILE UNDER LOAD.**



**Figure 3. Typical 400 A ATS.**

The Eaton contactor based ATS was designed with easy installation and simplified maintenance in mind. Two main panels comprise the contactor based ATS design:

1. Power panel; and
2. Microprocessor-based logic panel.

Each panel is independently mounted with interconnecting wiring terminated at the connector receptacles on the ATC-100 Controller. Door or individual panel removal is achieved without disturbing critical connections by removing the connectors from the receptacles and cutting the wire ties that secure the wires to the door.

Mounting the enclosure is simple using top and bottom mounting flanges with elongated (teardrop) mounting holes. These mounting holes, along with power panel positioning bolts and pre-tapped inserts, insure proper power panel mounting after the initial enclosure installation. Refer to Section 4 for specific mounting and modification details.

### 1.3 ATS Catalog Number Identification

Transfer switch equipment catalog numbers provide a significant amount of relevant information that pertains to a particular piece of equipment. The Catalog Number Identification Table (Table 1) provides the required interpretation information. An example is offered here to initially simplify the process.

**Example:** Catalog Number (circled numbers correspond to position headings in Table1).

① to ②   ③   ④   ⑤ to ⑥   ⑦   ⑧   ⑨ to ⑫   ⑬   ⑭   ⑮  
 AT C 1 C2 X 2 0400 W R U

The catalog number ATC1C2X20400WRU describes an ATS with the a 2 pole, 2 position Power Contactor mounted on a baseplate within the enclosure. The intelligence represented by the control panel is ATC-100 logic. The continuous current rating of this equipment is 400 A and applicable at 240 Vac, 60 Hz. The transfer switch equipment is enclosed in a NEMA 3R enclosure and is listed for UL applications.

### 1.4 Environmental Conditions

#### 1.4.1 Operational Conditions

Normally, an ATS is applied indoors in an electrical equipment room. In the appropriate enclosure, it can be used for outdoor applications where the equipment is subject to falling rain, freezing temperatures, and no greater than 90% humidity (non-condensing). The ambient temperature range for operation is between -20 and 70° C (-4 to 158° F).

### 1.5 Glossary

With respect to their use within this document and as they relate to transfer switch and controller operation, the following terminology is defined.

#### Available

A source is defined as “available” when it is within its undervoltage/ underfrequency/overfrequency setpoint ranges for the nominal voltage and frequency setting.

#### Connected

Connected is defined as when the input is shorted by an external contact or connection.

#### Failed or Fails

A source is defined as “failed” when it is outside of the applicable voltage and frequency setpoint ranges for the nominal voltage and frequency setting for a time exceeding 0.5 seconds after the time delay emergency fail (TDEF) time delays expires.

#### Failsafe

Failsafe is a feature that prevents disconnection from the only available power source and also forces a transfer or re-transfer operation to the only available power source.

#### Re-Transfer

Re-transfer is defined as a change of the load connection from the Generator to the Utility.

#### Utility

Utility is the primary source (normal source, normal power source, or normal).

#### Generator

Generator is the secondary source (generator/emergency source, emergency power source, emergency, standby, or backup source).

#### Utility: Failed or Fails

Utility is defined as “failed” when it is outside of its undervoltage setpoint ranges for the nominal voltage and frequency setting.

#### Generator: Failed or Fails

Generator is defined as “failed” when it is outside of its undervoltage/underfrequency/overfrequency (if applicable) setpoint ranges for the nominal voltage and frequency setting for a time exceeding 0.5 seconds after the Time Delay Emergency Fail (TDEF) time delay expires.

#### Transfer

Transfer is defined as a change of the load connection from the Utility to the Generator power source.

#### Unconnected

Unconnected is defined as when the input is not shorted by an external contact or connection.

**Table 1. Transfer Switch Catalog Number Explanation**

POSITIONS 1 TO 2 BASIC DEVICE		POSITION 3 SWITCHING DEVICE		POSITION 4 CONTROL PANEL		POSITIONS 5 TO 6 SWITCHING DEVICE				
Automatic Transfer Switch	AT	Contactor	C	ATC-100 Controller	1	2 Position Power Contactor		C2		
POSITION 7 SWITCHING DEVICE ARRANGEMENT	POSITION 8 NUMBER OF POLES	POSITIONS 9 TO 12 AMPERE RATING	POSITION 13 VOLTAGE/ FREQUENCY		POSITION 14 ENCLOSURE	POSITION 15 LISTING				
Reserved	X	Two (2)	400 A – 0400		240 Vac/60 Hz	W	Type 1	S	UL/CSA Listing	U
							Type 12	J	No Listing	X
							Type 3R	R		
							Open	K		

## SECTION 2: RECEIVING, HANDLING, AND STORAGE

### 2.1 Receiving

Every effort is made to ensure that the ATS equipment arrives at its destination undamaged and ready for installation. Packing is designed to protect internal components as well as the enclosure. Care should be exercised, however, to protect the equipment from impact at all times. Do not remove the protective packaging until the equipment is ready for installation.

When the ATS equipment reaches its destination, the customer should inspect the shipping container for any obvious signs of rough handling and/or external damage that occurred during transportation. Record any external and internal damage for reporting to the transportation carrier and Eaton, once a thorough inspection is complete. All claims should be as specific as possible and include the catalog and General Order numbers.

A shipping label affixed to the shipping container includes a variety of equipment and customer information, such as General Order Number and catalog numbers. Make certain that this information matches other shipping paper information.

Each transfer switch is packed securely with appropriate shipping materials to prevent damage during shipment. Do not remove or discard the packing material until the equipment is ready for installation.

Once the top packaging is removed from the shipment, the enclosure door can be opened. A plastic bag of documents will be found in the enclosure, usually attached to the inside of the enclosure. Important documents, such as test reports, wiring diagrams, and appropriate instruction leaflets, are enclosed within the bag and should be filed in a safe place.

### 2.2 Handling

As previously mentioned, ATS equipment is packaged for forklift movement. Protect the equipment from impact at all times and DO NOT double stack.

Once the equipment is at the installation location and ready to be installed, packaging material can be removed and discarded. Once the enclosure is unbolted from the wooden pallet, it can be hand moved to its installation position. Be careful not to damage the top or bottom enclosure mounting flanges. Refer to Section 4 of this manual for specific installation instructions.

### 2.3 Storage

Although well packaged, this equipment is not suitable for outdoor storage. The equipment warranty will not be applicable if there is evidence of outdoor storage. If the equipment is to be stored indoors for any period of time, it should be stored with its protective packaging material in place. Protect the equipment at all times from excessive moisture, construction dirt, corrosive conditions, and other contaminants.

It is strongly suggested that the package-protected equipment be stored in a climate-controlled environment with temperatures from -30 to 85°C (-22 to 185°F) and with a relative humidity of 80% or less. DO NOT, under any circumstance, stack other equipment on top of a transfer switch equipment enclosure, whether packaged or not.

## SECTION 3: EQUIPMENT DESCRIPTION

### 3.1 General

The ATS consists of two basic panels:

1. The power panel; and
2. The microprocessor-based logic panel.

These panels are interconnected via connector plugs and mounted in an enclosure (Figure 4).



Figure 4. Two Basic Panels of the ATS 400 A Model.

### 3.2 Power Panel

The power panel is used for making load, power, and neutral connections. The power contactor is mounted on a steel baseplate (Figure 5).

#### 3.2.1 Main Contacts

This ATS incorporates a power contactor. The main contacts connect and disconnect the load to and from the different power sources. The power contactor is mechanically and electrically interlocked to prevent the two sets of main contacts from being closed simultaneously.



Figure 5. Typical Power Panel for 400 A Model.

### 3.3 ATC-100 Logic Panel

The ATC-100 is a microprocessor-based transfer switch logic control package. The hardware and software of the controller contain the intelligence/supervisory circuits that constantly monitor the condition of the power sources. It provides the intelligence necessary for the operation of the ATS (Figure 6).

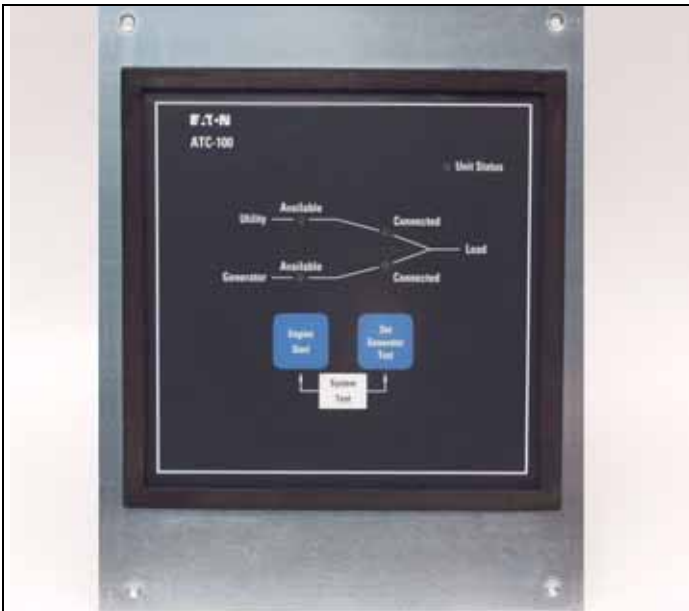

Figure 6. ATC-100 Logic Control Panel.

The ATC-100 controller has an operating temperature of -20 to 70°C (-4 to 158°F).

The controller circuit board is protected by an insulating conformal coating.

The specifications, under normal operating conditions, are as follows:

- Tolerance for voltage sensing function: ± 1% of setting
- Tolerance for frequency sensing function: ± 0.3 Hz of setting

### 3.4 Features

A variety of standard and optional features are available for Eaton ATSS. **All features or combinations of features may not be available on specific ATSS.** All features and/or accessories are Underwriters Laboratories (UL) listed unless noted.

#### 3.4.1 Standard Features

The following is a list of the standard features for the ATC-100 Controlled ATS.

##### 1. Time Delay Normal to Emergency (TDNE)

This feature provides a time delay when transferring from the Utility to the Generator power source. Timing begins when the Generator becomes available. It permits controlled transfer of the load circuit to the Generator.

Jumper selectable at 2 seconds or 15 seconds.

##### 2. Time Delay on Engine Starting (TDES)

This feature provides a time delay of the signal to initiate the engine/generator start cycle in order to override momentary power outages or voltage fluctuations of Utility.

Fixed at 3 Seconds.

##### 3. Time Delay Emergency to Normal (TDEN)

This feature provides a time delay of the re-transfer operation to permit stabilization of Utility. Timing begins when the Utility becomes available. If the Generator fails during timing, then re-transfer is immediate overriding the time delay.

Fixed at 5 Minutes.

##### 4. Time Delay for Engine Cool-down (TDEC)

This feature provides a time delay of the signal to initiate the engine/generator stop cycle after the re-transfer operation. This allows the engine/generator to cool down by running unloaded. Timing begins on completion of the re-transfer cycle.

Fixed at 1 Minute

##### 5. Generator Monitoring and Protection

This feature provides monitoring and protection based on the Generator voltage and/or frequency setpoints. All feature 5 functions are Failsafe operations.

##### 5J. All Phase Undervoltage and Underfrequency Protection

Undervoltage:

- Dropout: 80% of nominal
- Pickup: 90% of nominal

Underfrequency:

- Dropout: 90% of nominal
- Pickup: 95% of nominal

##### 5N. All Phase Overfrequency

Overfrequency:

- Dropout: 115% of nominal
- Pickup: 110% of nominal

**6. Test Operators**

Eaton ATSS are provided with a Test Pushbutton that simulates a loss of the Utility power source as standard (Feature 6B). All programmed time delays (TDNE, TDEN, etc.) will be performed as part of the Test. Engine run time of the Test is equal to the Generator Test (Feature 23) programmed setpoint. All Tests are Failsafe protected.

**6B. Test Pushbutton**

Programmable setpoints include:

1. Load or No Load Testing, or Off
2. Engine run time equal to the Generator Test (Feature 23) setting

**7. Time Delay Emergency Fail (TDEF)**

This feature provides a time delay that prevents a connected Generator power source from being declared "Failed" in order to override momentary generator fluctuations. If the Generator power source remains in the failed state then, 0.5 seconds after the TDEF timer expires, the transfer switch will proceed with the programmed sequence for retransfer.

Fixed at 6 Seconds

**12. Power Source Annunciation**

This feature provides LEDs to give switch position and power source availability indications.

**Switch Position**

Provides LEDs to indicate the switch position

**12C. Utility - Source Connected**

This feature provides a green LED that, when lit, indicates the load is connected to the Utility.

**12D. Generator - Source Connected**

This feature provides a red LED that, when lit, indicates the load is connected to Generator.

**Power Source Availability**

Provides LEDs to indicate if a power source is available. LEDs may be integral or separate from the controller.

**12G. Utility - Available**

This feature provides a white LED that, when lit, indicates the Utility is available.

**12H. Generator - Available**

This feature provides an amber LED that, when lit, indicates the generator is available.

**23. Generator Test**

This feature provides a means for automatic testing of the engine generator set or standby power system. All programmed time delays will be performed during plant exercise operations.

**23A. Generator Test Selectable – Off 7/14/28 Day Interval**

This feature provides for automatic test operation of the generator. Available test cycles are 7, 14, or 28 days with a 15-minute duration.

Programmable setpoints allow for selection of three test cycles:

- Generator Start/Run Only (No Load);
- Generator Test with Load Transfer; or
- Disabled

This is a "Failsafe" operation.

**26. Utility - Monitoring and Protection**

This feature provides Utility monitoring and protection functions. If the Utility power supply fails, then the ATC-100 will begin the sequence of operations necessary to transfer the load circuit to the Generator power supply. All Feature 26 monitoring and protection functions are Failsafe operations.

**26P. All Phase Undervoltage Protection**

Undervoltage:  
Dropout: 80% of nominal  
Pickup: 90% of nominal

**41. Space Heater with Thermostat**

This feature provides a space heater and non-adjustable thermostat. External control power is not required.

**41A. Space Heater with Thermostat - 100 Watt**

This feature provides a 100 watt (W) space heater with a non-adjustable thermostat.

**3.4.2 Optional Features**

The following is a list of the optional features for the ATC-100 Controlled ATS. **All features or combinations of features may not be available on specific ATSS**

**14. Relay Auxiliary Contacts**

**14G. Utility Present:** Provides two (2) normally open and two (2) normally closed contacts. The relay is energized when the Utility is available.

**14H. Generator Present:** Provides two (2) normally open and two (2) normally closed contacts. The relay is energized when the Generator is available.

**15. Switch Position Indication Contact**

This feature provides a contact that indicates if the power switching device is in the "Open" or "Closed" position.

**15E. Utility Position Indication Contact**

This feature provides 1 dry form "C" contact that indicates the position of the Utility power switching device.

**15F. Generator Position Indication Contact**

This feature provides 1 dry form "C" contact that indicates the position of the Generator power switching device.

**26M. Generator Utility Sensing**

Allows for the switch to operate with generators that have internal utility sensing. This option comes as a kit that needs to be field installed.

**38. Stainless Steel Logic Cover**

**38C. SS ATC-100 Cover**

This feature provides a pad-lockable stainless steel cover for the ATC-100 Controller.

**3.5 Enclosure**

The rugged steel ATS enclosure is supplied with three door hinges, regardless of enclosure size. They ensure proper support of the door and door mounted devices (Figure 7). The hinges have removable hinge pins to facilitate door removal. Certain procedures, such as switch mounting, are simplified with the door removed. The doors are supplied as standard with pad-lockable latches.

The rear of the enclosure is supplied with teardrop shaped holes in the top and bottom mounting flanges to facilitate mounting. Cable entry holes are the responsibility of the customer.

ATS enclosures and all internal steel mounting plates, such as the power panel mounting plate, go through a pretreatment cleaning system prior to painting to ensure a durable finish.

The standard ATS enclosure is NEMA Type 3R for general outdoor use. However, a variety of enclosures are available to address almost any environmental circumstance (see Table 2).



Figure 7. Typical Type 3R Enclosure (Door Closed).

**Table 2. Transfer Switch Equipment Enclosures**

NEMA TYPE	DESIGN	PROTECTION
Open	Indoor	
1	Indoor	Enclosed Equipment
3R	Outdoor	Rain, Ice Formation
12	Indoor	Dust, Dirt, and Non-Corrosive Liquids

**3.6 Standards**

Eaton ATS equipment, enclosed in any of the enclosures listed in Table 2, is listed for application by UL and ULC. In addition, Eaton ATSS are listed in File E38116 by Underwriters Laboratories, Inc. under Standard UL 1008. This standard covers requirements for automatic transfer switches intended for use in ordinary locations to provide lighting and power as follows:

- a. In emergency systems, in accordance with articles 517 and 700 in the National Electrical Code, ANSI/ NFPA 70, and the National Fire Protection Association No. 76A; and/or
- b. In standby systems, in accordance with article 702 of the National Electrical Code; and/or
- c. In legally required standby systems in accordance with article 701 of the National Electrical Code.

Eaton ATSS are available to meet NFPA 110 for emergency and standby power systems, and NFPA 99 for health care facilities when ordered with the appropriate options.

Standard UL 1008 for ATSS lists devices under the reexamination program which only require a continual physical reexamination of the components used in the product to ensure consistency with the originally submitted device. Follow-up testing is not required by UL 1008.

## SECTION 4: INSTALLATION AND WIRING

### 4.1 General

Eaton ATCs are factory wired and tested. Installation requires solidly mounting the enclosed unit and connecting power cables and auxiliary pilot circuits. Physical mounting procedures and power cable connections are covered in this section. All other required wiring or electrical connection references are covered in a separate Customer Wiring Booklet packaged with the ATC.

Locate the wiring schematic, review it, and keep it readily available for reference purposes during installation and testing. Once an ATC is properly installed and wired, it should be mechanically and electrically checked for proper installation and operation. The procedures for these initial mechanical and electrical checks are outlined in Section 6 of this instruction manual.

### WARNING

**BE CERTAIN THAT THE SOLID STEEL DOOR IS PROPERLY INSTALLED BEFORE THE TRANSFER SWITCH EQUIPMENT IS PUT INTO SERVICE. THE DOOR PROVIDES PROTECTION FROM DANGEROUS VOLTAGES AT THE LINE AND LOAD TERMINALS WHEN THE EQUIPMENT IS IN OPERATION. FAILURE TO DO SO COULD RESULT IN PERSONAL INJURY OR DEATH.**

### 4.2 Mounting Location

Choose a location that offers a flat, rigid mounting surface capable of supporting the weight of the enclosed ATC equipment. For standard ATCs, avoid locations that are moist, hot, or dusty. However, Eaton offers optional enclosure designs that can be used in special environments. If there are any doubts as to a location's suitability, discuss them with your Eaton representative.

Check to make certain that there are no pipes, wires, or other mounting hazards in the immediate mounting area that could create a problem.

Carefully remove all packing material from the ATC at the installation site. Even though an equipment inspection should have been made when the equipment was received, make another careful inspection of the enclosure and the enclosed ATC components as the packing material is removed and the enclosure readied for mounting. Be especially alert for distorted metal, loose wires, or damaged components.

### 4.3 Mounting Procedure

### CAUTION

**SINCE THE ENCLOSED ATC MUST BE LIFTED INTO PLACE FOR MOUNTING, BE CERTAIN THAT ADEQUATE RESOURCES ARE AVAILABLE FOR LIFTING TO AVOID PERSONNEL INJURIES OR EQUIPMENT DAMAGE.**

All equipment enclosures and power panels are of the same design. Only the overall physical dimensions change. Note that the enclosure is provided with four teardrop (elongated) mounting holes, two in the top mounting flange and two in the bottom.

Cable entry holes are not part of the enclosure when shipped from the factory and must be provided in the field, either before or after mounting the enclosure. Cable access may be from the top, bottom, and/or side.

### CAUTION

**EXTREME CARE SHOULD BE TAKEN TO PROTECT THE TRANSFER SWITCH FROM DRILL CHIPS, FILINGS, AND OTHER CONTAMINANTS WHEN MAKING THE CABLE ENTRY HOLES. EXTREME CARE SHOULD ALSO BE TAKEN WHEN MOUNTING THE ENCLOSURE TO PREVENT COMPONENT DAMAGE OR A FUTURE MALFUNCTION.**

### NOTICE

**THE INSTALLATION MUST FULLY COMPLY WITH ALL APPLICABLE CODES, STANDARDS, AND REGULATIONS.**

With the enclosed ATC equipment unpacked and ready for mounting, proceed with the following steps.

- Step 1:** The ATC enclosure door is hinge mounted with removable hinge pins. To simplify the mounting procedure and avoid damaging the door-mounted logic panel, it is strongly suggested that the door be carefully removed and put it in a safe place until mounting is complete. To remove the door, open the door and disconnect the connectors at the back of the ATC-100 logic panel. Remove the wire ties securing the harness to the inside of the door. Carefully remove the hinge pins then the door from the enclosure.
- Step 2:** Install the required upper and lower mounting bolt anchors and the two upper mounting bolts in the mounting surface.
- Step 3:** Gently lift the enclosure and guide the teardrop holes in the upper mounting flange over the upper mounting bolts. Do not completely tighten the bolts at this time.
- Step 4:** While still supporting the enclosure, install the two lower mounting bolts in the lower mounting flange. Again, do not completely tighten the bolts at this time. Use shims, if required, to prevent deformation of the enclosure if the mounting surface is distorted.
- Step 5:** Tighten all four mounting bolts after any required shimming is completed.

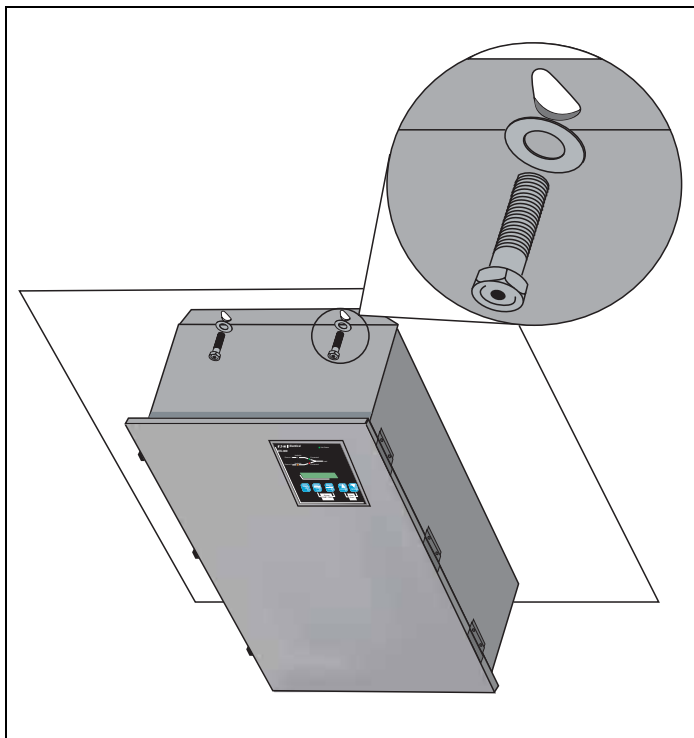

Figure 8. Typical Mounting of the ATS to a Mounting Surface.

Step 6: Double check to ensure that all packing and shipping materials have been removed.

4.4 Power Cable Connections

**! WARNING**

POWER CONDUCTORS MAY HAVE VOLTAGE PRESENT THAT CAN CAUSE SEVERE PERSONAL INJURY OR DEATH. DE-ENERGIZE ALL POWER OR CONTROL CIRCUIT CONDUCTORS TO BE CONNECTED TO THE ATS EQUIPMENT BEFORE BEGINNING TO WORK WITH THE CONDUCTORS AND/OR TERMINATING THEM TO THE EQUIPMENT.

**! CAUTION**

USE OF CABLE LUGS NOT DESIGNED FOR THE ATS MAY CAUSE HEATING PROBLEMS.

**! CAUTION**

TO HELP PREVENT COMPONENT DAMAGE OR FUTURE MALFUNCTIONS, USE EXTREME CARE TO KEEP CONTAMINANTS OUT OF THE ATS EQUIPMENT WHEN MAKING POWER CABLE CONNECTIONS.

**! CAUTION**

RUN THE POWER CABLE THROUGH THE GUTTER SPACE PROVIDED TO THE RIGHT OR LEFT OF POWER PANEL.

Test all power cables prior to connection to the unit to ensure that the conductors or cable insulation have not been damaged while being pulled into position.

Power cables are to be connected to solderless screw type lugs located on the ATS switching devices. Refer to the separate Customer Wiring Booklet supplied with the ATS equipment for power termination. Verify that the lugs supplied will accommodate the power cables being used. Also verify that the cables comply with local electrical codes. Standard ATS equipment, as supplied from the factory, will accommodate the wire sizes shown in Table 3.

Carefully strip the insulation from the power cables to avoid nicking or ringing of the conductor strands. Prepare the stripped conductor termination end by cleaning it with a wire brush. If aluminum conductors are used, apply an appropriate joint compound to the clean conductor surface area.

**! WARNING**

IMPROPER POWER CABLE CONNECTIONS CAN CAUSE EXCESSIVE HEAT AND SUBSEQUENT EQUIPMENT FAILURE.

Tighten the cable lugs to the torque identified on the label affixed to the door of the unit.

4.5 Wiring

**! WARNING**

POWER CONDUCTORS AND CONTROL WIRING MAY HAVE VOLTAGE PRESENT THAT CAN CAUSE SEVERE PERSONAL INJURY OR DEATH. DEENERGIZE ALL POWER OR CONTROL CIRCUIT CONDUCTORS BEFORE BEGINNING TO PERFORM ANY WIRING ACTIVITY TO OR WITHIN THE ATS EQUIPMENT.

Power sources, load conductors, and control wiring should be connected to locations as indicated in the Customer Wiring Booklet supplied with the ATS equipment.

**! CAUTION**

ENSURE THE ATC-100 VOLTAGE IS SET CORRECTLY. IT SHOULD BE THE SAME AS THE UTILITY AND THE GENERATOR LINE VOLTAGES. OPERATING THE EQUIPMENT ON IMPROPER VOLTAGE CAN CAUSE EQUIPMENT DAMAGE.

Once the ATS equipment has been installed and wired, perform the initial mechanical and electrical procedures as outlined in Section 6 to verify that the equipment is installed and operating properly.

Table 3. Transfer Switch Equipment Wire Sizes

TRANSFER SWITCH AMPERE RATING	WIRE SIZE RANGES	NUMBER OF CABLES PER PHASE	TERMINAL TEMPERATURE RATING °C (°F)
400	#4-600 KCMIL or (2) 1/0-250 KCMIL	1 or 2 - depending on wire size used	75 (167)

**ATC-100 Contactor Based Transfer Switch**

**4.6 Generator Start Connection**

The generator start contact connections are located below the ATC-100 controller. A contact closes or opens between the terminals 1, 2, and 3 on the J5 connector of the ATC-100 Controller (see Figure 9) when an engine start signal is provided by the ATS logic. The wiring diagram provides additional generator start connection information. Use the proper wire size as listed by the generator set (Genset) manufacturer.

**NOTICE**

**PRIOR TO MAKING THE GENERATOR START CONNECTION TO THE SWITCH, SET THE ENGINE GENERATOR CONTROLS SELECTOR SWITCH IN THE OFF POSITION TO PREVENT AN UNWANTED GENERATOR START. CONTROL WIRING, SUCH AS THE ENGINE START WIRES, MUST BE RUN IN A SEPARATE CONDUIT FROM THE POWER CABLES.**

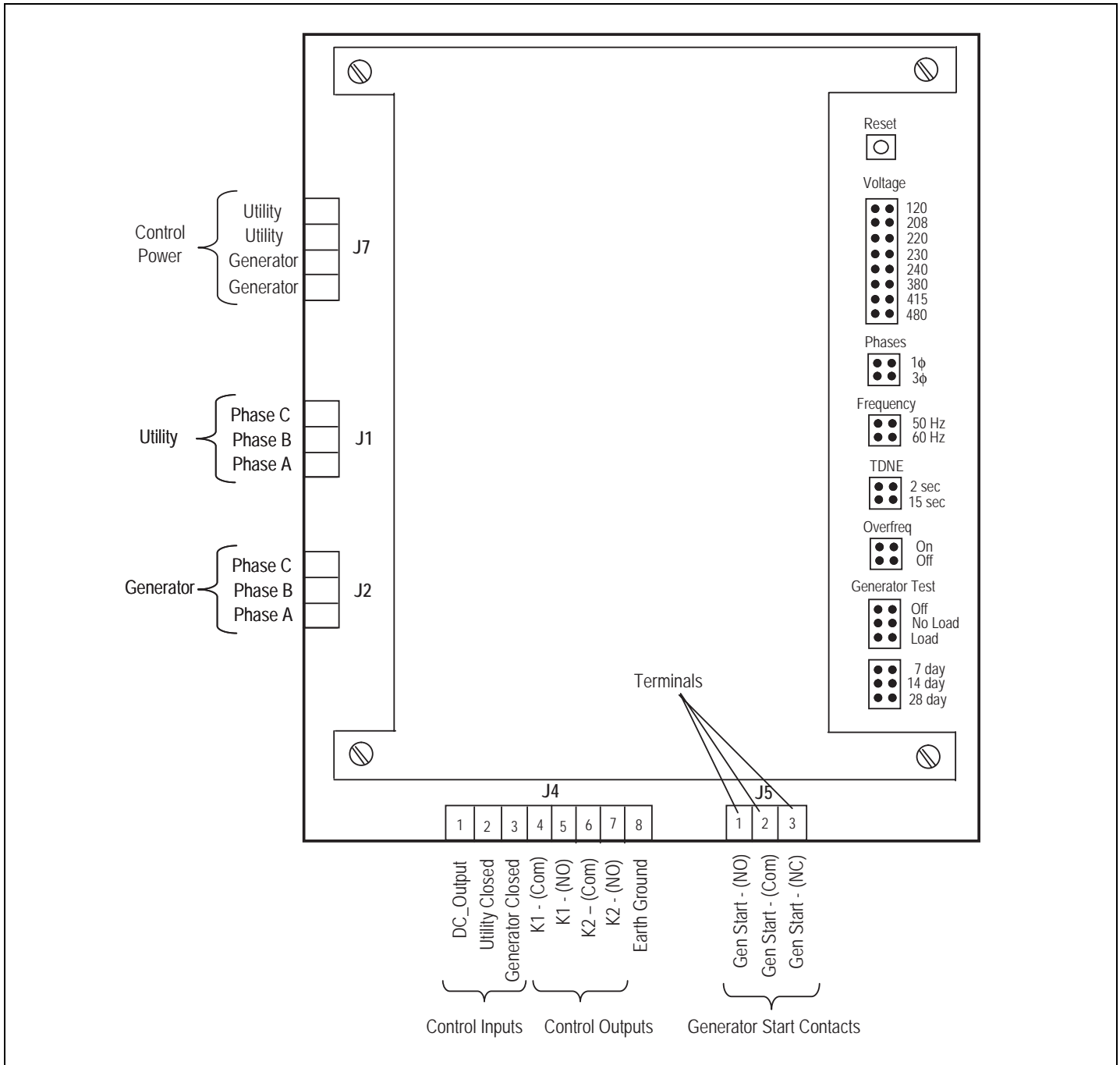

Figure 9. Location of Terminals 1,2, and 3 on J-5 Connector.

### 4.7 Preliminary Checks

After the ATS enclosure is installed and power cables are connected to the equipment, thoroughly inspect the unit to ensure that no tools were left inside and that the cabinet is free of debris. If necessary, use a vacuum cleaner to remove any and all construction or installation debris from the equipment.

Read and understand all labels on the equipment. Review and understand the wiring diagrams supplied with the equipment. Note any optional accessories that may have been furnished with this unit and review their operation.

Verify that the phase-to-phase line voltages of both the utility and generator power sources are the same and that they match the rated voltage as indicated on the ATS ratings label.

### CAUTION

SEVERE EQUIPMENT DAMAGE CAN RESULT IF THE UNIT IS NOT APPLIED AT PROPER VOLTAGE. DO NOT ENERGIZE THE EQUIPMENT IF THE SUPPLY VOLTAGES DO NOT MATCH EQUIPMENT RATINGS LABEL.

### 4.8 Terminal Block Wire Installation and Removal

Proceed with the following steps and associated figures to install or remove terminal block wiring.

**Step 1:** Figure 10 shows two tension clamp terminal blocks. There is a large one and small one, but the operation is the same for both. A small tool, such as a screwdriver, will be pushed into the square hole next to the wire hole and a wire will be inserted into the larger circular hole on the outer edge.

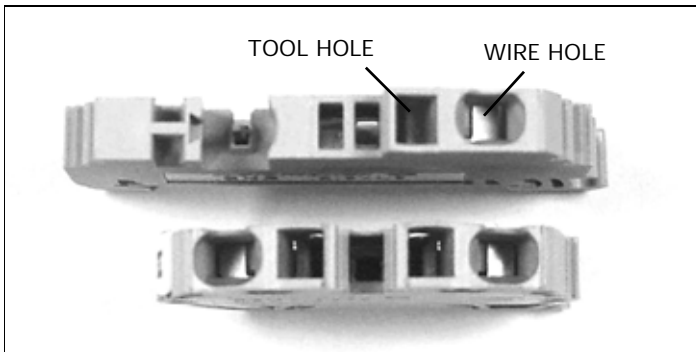

Figure 10. Tension Clamp Terminal Blocks.

**Step 2:** Begin by inserting a small, blade screwdriver into the square (tool) hole with the flat surface of the screwdriver against the back wall of the hole (see Figure 11). With a little bit of force, push the screwdriver in on a slight angle toward the center of the clamp. Be sure to slide it in until it clicks. You will then see the clamp open in the wire hole.

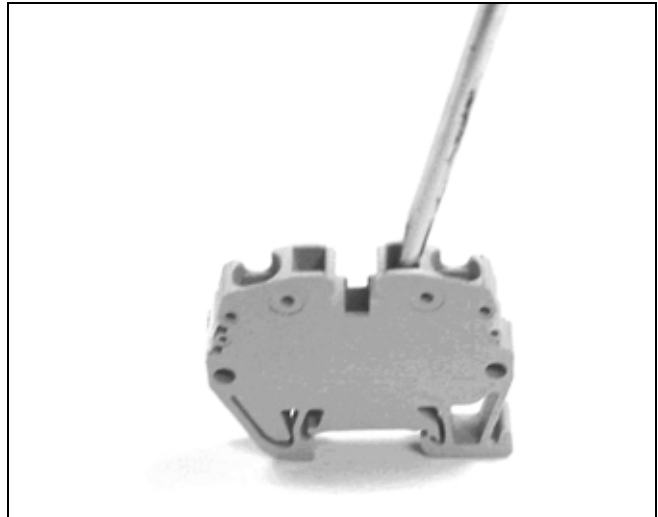

Figure 11. Screwdriver Inserted in the "Tool" Hole.

**Step 3:** Once the screwdriver is in place, obtain a stripped wire (strip about 0.25 in.) and insert it into the larger circular wire hole. Push the wire in until it can go no further (see Figure 12).



Figure 12. Wire Inserted in the "Wire" Hole.

## ATC-100 Contactor Based Transfer Switch

### SECTION 5: OPERATION

#### 5.1 General

An ATS provides a power contactor to connect and disconnect the load to and from the Utility and the Generator power sources (Section 3.2.1).

#### 5.2 Manual Operation

---

#### **⚠ WARNING**

DO NOT ATTEMPT TO MANUALLY OPERATE THE ATS WITH THE UTILITY OR THE GENERATOR AVAILABLE.

---

#### **⚠ WARNING**

HIGH VOLTAGES ARE PRESENT IN AND AROUND TRANSFER SWITCH EQUIPMENT. BEFORE ATTEMPTING TO MANUALLY TRANSFER, DISCONNECT THE LINE POWER FROM THE EQUIPMENT BEING SERVICED BY OPENING AND LOCKING OUT, IF POSSIBLE, THE NEXT HIGHEST DISCONNECT DEVICE. FAILURE TO FOLLOW THIS PROCEDURE COULD CAUSE SEVERE PERSONAL INJURY AND/OR DEATH.

ALWAYS TURN THE UTILITY POWER OFF AND TURN THE GENERATOR CONTROL SELECTOR SWITCH TO THE "OFF" POSITION BEFORE ATTEMPTING A MANUAL TRANSFER.

---

To manually operate:

1. Disconnect all sources of power.
2. Disconnect the J7 connector from the ATC-100 controller.
3. Depress the "trip" button on the contactor.
4. Locate the manual lever on the left side of the contactor.
5. Locate the yellow handle used to manually transfer the switch.
6. Attach the yellow handle to the manual lever.
7. Move the lever up to go to Utility or move the lever up to go to the Generator.
8. Once the manual operation is complete and automatic operation is desired, connect the sources of power.
9. Check for 120 Vac at the J7 plug across the Utility - Utility inputs if Utility is available.
10. Check for 120 Vac at the J7 plug across the Generator - Generator inputs if the Generator is available (see the troubleshooting guide if values are above 130 Vac or below 110 Vac).
11. Insert the J7 connector into the controller.
12. Follow the testing procedure in Section 6 to ensure proper automatic operation.



Figure 13. ATS Manual Operating Handle in Use.

#### 5.3 Automatic Transfer

The operating sequence of an ATS is dictated by the switch's standard features and selected options. Operation of an ATS during Utility power source failure and Utility power source restoration will be described here with only standard options included on the switch. Additional options, as described in Section 3, can change sequences and timing, depending upon the options selected. It is strongly suggested that you become familiar with additional options selected with the particular ATS and their effect on the normal operation of an ATS.

##### 5.3.1 Utility Power Source Failure

Standard Utility power source failure is defined as a reduction or loss of voltage. If this occurs, the sequence of operation is as follows.

1. Failure of the Utility is detected by the controller intelligence.
2. When the controller detects a failure, the engine contacts close or open (after delay if programmed) and start the engine-driven generator.

3. When the Generator voltage reaches its operation rating, the K2 relay closes, starting the transfer operation. This operating sequence causes the contactor to open the Utility and close on Generator.
4. The load is now transferred to the Generator power source.

### 5.3.2 Utility Power Source Restoration

1. A return to the Utility power source begins when the voltage in phase-to-phase in a single sensing unit is restored to a preset value.
2. At the preset voltage, the controller will cause the K1 relay to change state. This starts the return to the Utility power source.
3. During this sequence, the contactor opens the Generator and closes on the Utility.
4. Simultaneously, the engine cool-down timer initiates the shut down of the engine driven generator.
5. Transfer of the load back to the Utility power source is now complete.

## SECTION 6: TESTING AND PROBLEM SOLVING

### 6.1 Testing

After the ATS equipment is initially installed or during planned outages, the installation should be tested to ensure that all equipment operates properly. This attention to detail will help avoid unexpected malfunctions. Mechanical and/or electrical tests should be performed as described in this section.

The frequency of subsequent testing should be based on recommendations of the Genset manufacturer. Use the system test pushbutton to check the electrical operation of the switch.

### WARNING

HIGH VOLTAGES ASSOCIATED WITH OPERATIONAL TRANSFER SWITCH EQUIPMENT PRESENT A SHOCK HAZARD THAT CAN CAUSE SEVERE PERSONAL INJURY OR DEATH. USE EXTREME CAUTION TO AVOID TOUCHING ELECTRICAL CONNECTIONS WHENEVER INSPECTING OR TESTING THE EQUIPMENT.

IN ADDITION, IMPROPER OPERATION OF THE GENERATOR SET PRESENTS A HAZARD THAT CAN CAUSE SEVERE PERSONAL INJURY OR DEATH. OBSERVE ALL SAFETY PRECAUTIONS IN YOUR GENERATOR SET OPERATIONS AND INSTALLATION MANUALS.

#### 6.1.1 Mechanical and/or Electrical Testing

### NOTICE

SINCE FEATURE 4 (TIME DELAY ENGINE COOL-OFF), AS DESCRIBED IN SECTION 3, IS A STANDARD FEATURE, AN ENGINE START SIGNAL WILL BE PRESENT FOR A PERIOD OF TIME WHEN THE SWITCH IS FIRST ENERGIZED. THE PERIOD OF TIME IS EQUAL TO THE TIMER SETTING. TO AVOID STARTING THE ENGINE DURING THIS TIME PERIOD, TURN THE GENERATOR CONTROLS TO THE OFF POSITION.

Energize the ATS equipment as described in Sections 6.1.2 through 6.1.6. Insure that all safety precautions are taken and that all **WARNINGS** and **CAUTIONS** are observed.

#### 6.1.2 No Voltage Steps

With no voltage available on either power source, proceed as follows.

- Step 1:** The generator engine start controls should be in the OFF position to prevent an undesired start.
- Step 2:** Ensure that the Controller has been set to the proper applied system voltage.
- Step 3:** Check all ATS loads to ensure that they are ready to be energized.

#### 6.1.3 Connecting the Power Sources

- Step 1:** Close the Utility power source upstream protection device. The Utility power switching device should close.
- Step 2:** Connect the engine start battery cable.
- Step 3:** With the emergency generator in the OFF position, close the Generator power source upstream protective device, assuming such a device used.

**ATC-100 Contactor Based Transfer Switch**

**NOTICE**

AT THIS POINT, AND PRIOR TO MAKING ANY ATTEMPT TO ENERGIZE THE ATS EQUIPMENT, THE ENGINE-DRIVEN GENERATOR SHOULD BE OPERATED. IF NECESSARY, THE VOLTAGE REGULATOR ON THE GENERATOR SHOULD BE ADJUSTED ACCORDING TO THE MANUFACTURER'S RECOMMENDATIONS. THE ATS EQUIPMENT WILL RESPOND ONLY TO THE RATED VOLTAGE AND FREQUENCY PROGRAMMED INTO THE CONTROLLER.

**Step 4:** Close any generator engine-start controls opened as a result of actions taken in Step 1, Section 6.1.2.

**Step 5:** Where required, use an accurate voltmeter to check phase-to-phase and phase-to-neutral voltages present at the transfer switch Utility, Generator, and/or load terminals.

**6.1.4 Operational Checks**

**Step 1:** Check to ensure that the Utility switching device is in the CLOSED position. This should have been done in Section 6.1.3, Step 1.

**Step 2:** Initiate an automatic transfer operation from the Utility to the Generator power source by pressing the < **System Test** > pushbuttons (Engine test and set generator test) two times.

- a. After the Time Delay Engine Starting (TDES) has timed out, the engine should start, run, and build up to normal voltage and frequency.
- b. The transfer switch will transfer to the Generator power source after the Time Delay Normal to Emergency (TDNE) times out.

**Step 3:** Initiate an automatic transfer operation back to the Utility power source by pressing the < **System Test** > pushbuttons (Engine Test and Set Generator Test) one time.

- 1. After the Time Delay Emergency to Normal timer (TDEN) has timed out, the transfer switch will transfer back to the Utility power source.
- 2. The Time Delay for Engine Cool-Off (TDEC) will allow the engine to run unloaded for a preset time after transfer to the Utility power source is completed.

**6.1.5 Alternate Tests**

1. Alternate operational tests may be possible depending upon the options provided with any given ATS. Refer to the schematic diagram provided with the ATS equipment, along with the specification nameplate, to determine the exact options provided.

 **WARNING**

DO NOT ATTEMPT TO MANUALLY OPERATE THE ATS WITH THE UTILITY POWER SOURCE CONNECTED AND AVAILABLE.

DO NOT ATTEMPT TO MANUALLY OPERATE THE ATS WITH THE GENERATOR POWER SOURCE CONNECTED AND AVAILABLE.

**6.2 Problem Solving**

 **WARNING**

HAZARDOUS VOLTAGES IN AND AROUND ATS EQUIPMENT DURING THE PROBLEM SOLVING PROCESS CAN CAUSE SEVERE PERSONAL INJURY AND/OR DEATH. AVOID CONTACT WITH ANY VOLTAGE SOURCE WHILE PROBLEM SOLVING.

 **WARNING**

ONLY PROPERLY TRAINED PERSONNEL, FAMILIAR WITH THE ATS EQUIPMENT AND ITS ASSOCIATED EQUIPMENT, SHOULD BE PERMITTED TO PERFORM THE PROBLEM SOLVING FUNCTION. IF AN INDIVIDUAL IS NOT QUALIFIED TO PERFORM THE PROBLEM SOLVING FUNCTION, THE INDIVIDUAL SHOULD NOT ATTEMPT ANY OF THESE PROCEDURES.

A basic problem-solving effort is the first step to take prior to calling for assistance. Frequently, the effort will successfully address most problems encountered. The problem solving procedure is presented in the Troubleshooting Guide. Remember, only qualified individuals familiar with the ATS equipment and the system in which it is applied should attempt these problem solving procedures.

If a problem persists after having completed the problem solving procedure, contact a Eaton representative for further assistance. When calling for assistance, the following is the minimum information required to properly address the need:

- 1. Style number of ATS, if applicable;
- 2. Catalog number of ATS;
- 3. Actual location of the ATS (type of facility, address, etc.);
- 4. Company name and name and position of individual representing company;
- 5. Basic description of the situation as it exists; and
- 6. Any results of the problem solving steps taken and/or readings taken.

## SECTION 7: ADJUSTMENTS

### 7.1 General

Refer to I.B. 01602019E, supplied with the ATS for ATC-100 Controller adjustments and programming.

## SECTION 8: MAINTENANCE

### 8.1 Introduction

**WARNING**

**HIGH VOLTAGES ARE PRESENT IN AND AROUND ATS EQUIPMENT. BEFORE INSPECTING OR MAINTAINING THIS EQUIPMENT, DISCONNECT THE LINE POWER FROM, THEN LOCK OUT, IF POSSIBLE, THE NEXT HIGHEST DISCONNECT DEVICE. FAILURE TO FOLLOW THIS PROCEDURE COULD CAUSE SEVERE PERSONAL INJURY AND/OR DEATH.**

In general, ATS switch equipment is designed to be relatively maintenance free under normal usage. However, because of the variability of application conditions and the importance placed on dependable operation by this type of equipment, inspection and maintenance checks should be made on a regularly scheduled basis. Since equipment maintenance will consist mainly of keeping the equipment clean, the frequency of maintenance will depend to a large extent on the cleanliness of the equipment's surroundings. If a significant amount of dust or foreign matter is present, a more frequent maintenance schedule should be followed.

It is suggested that visual inspections of the equipment be made on a regular basis, not just during scheduled periods. Always be alert for an accumulation of dirt in and around the structure; loose parts; and/or hardware, cracks, and/or discoloration to insulation; and damaged or discolored components.

### 8.2 Procedures

A suggested maintenance procedure is outlined in Table 4.

**Table 4. Periodic Maintenance Procedures**

STEP	ACTION
a. Make the ATS equipment safe for inspection and/or maintenance.	Disconnect the line power from equipment being serviced by opening the next highest disconnect device. Make certain that any accessory control power is switched off by disconnecting all control plugs.
b. Inspect the structure area for safety hazards or potential maintenance problems.	Inspect the area, especially where switching device is installed, for any safety hazards, including personnel safety and fire hazards. Exposure to certain chemical vapors can cause deterioration of electrical connections.  Inspect for accumulated dirt, loose hardware, or physical damage.  Examine the primary insulation for evidence of cracking or overheating. Overheating will show as discoloration, melting, or blistering of conductor insulation, or as pitting or melting of conductor surfaces due to arcing.  Inspect the secondary control connections for damage and the control wiring for insulation integrity.
c. Inspect the power contactor for dust, dirt, soot, grease, moisture, or corrosion.	Remove dust, dirt, soot, grease, moisture, and corrosion contamination from the surface of the switching device using a dry soft lint-free cloth, dry soft bristle brush, and vacuum cleaner. Do not blow debris into the power contactor. If contamination is found, look for the source and fix the problem.
d. Check for material integrity, uneven wear, discoloration, or loose hardware.	Severe material cracking will require replacement and loose hardware will need to be tightened.
e. Check the terminals and connectors for looseness or signs of overheating.	Overheating will show as discoloration, melting, or blistering of the conductor insulation. Connections that do not have signs of looseness or overheating should not be disturbed.
f. Exercise the power contactor if it is not often exercised while in operation. This will permit a "wiping" action by the contacts.	If the power contactor is used for frequent switching during normal operation, this step can be disregarded.
g. Return the ATS equipment to service.	Make certain all barriers are in place and doors closed. Reapply secondary and primary power.

**ATC-100 Contactor Based Transfer Switch**

**SECTION 9: RENEWAL PARTS GUIDE**

**9.1 General**

Refer to Figure 14 for assistance with selecting and ordering selected ATS renewal parts.

**Example:** To order the transformer pack for an **ATC1C2X20400WRU** transfer switch, order Catalog Number **TSTXFP** as shown in Figure 14.

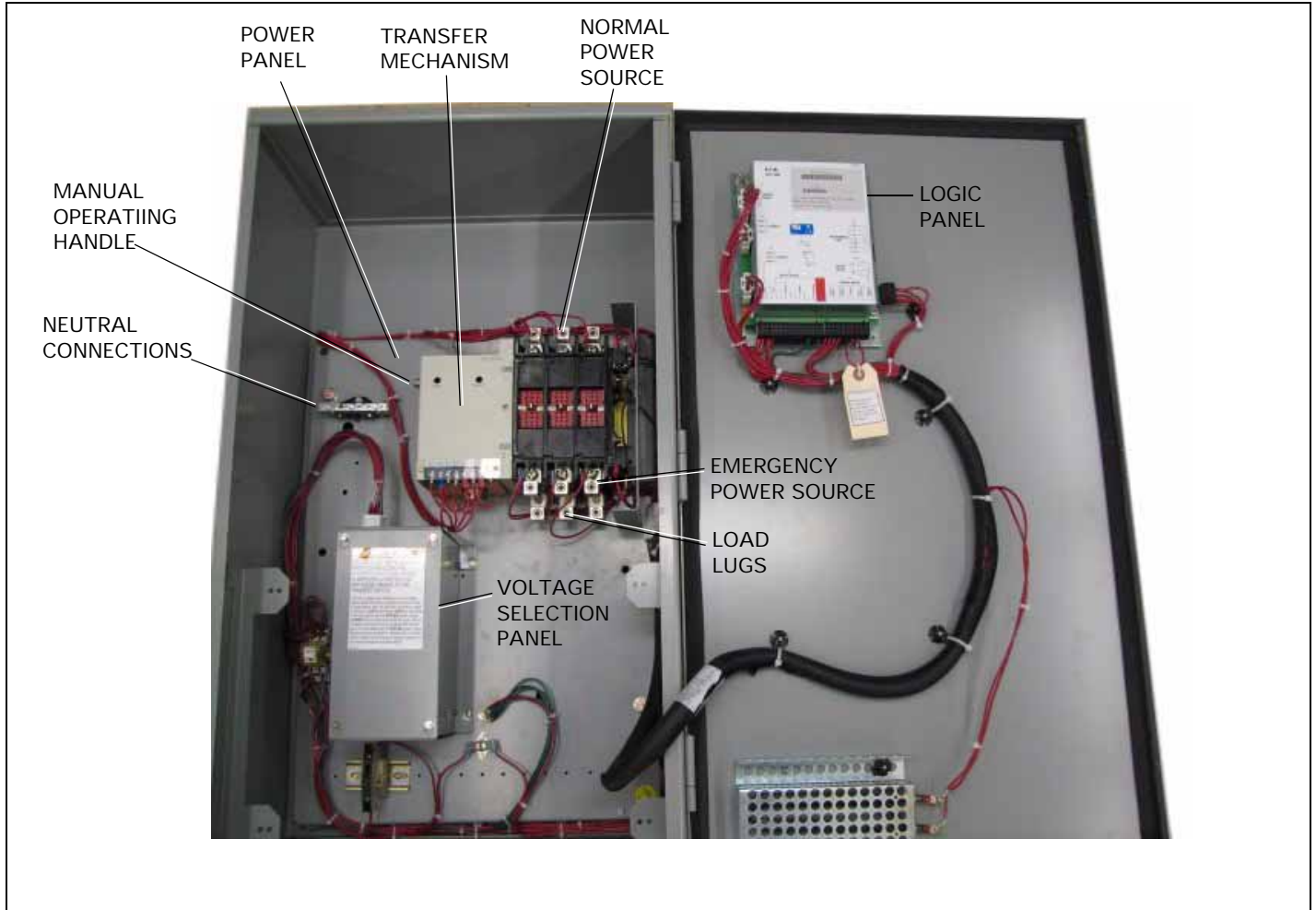

ATC-100 CONTROLLER	ATC100
Transformer pack	TSTXFP
Power Panel	TSTPC2X20400: 400A 2P,
100 W space heater	TSSH100
Wiring Harness	5724B93G05

**Figure 14. Typical ATC-100 Controlled ATS.**

**SECTION 10: ATC-100 CONTACTOR BASED  
ATS QUICK START INSTRUCTIONS**

**⚠ WARNING**

THESE QUICK START INSTRUCTIONS ARE NOT A COMPLETE SOURCE OF INFORMATION ON THE ATC-100 CONTROLLED ATS EQUIPMENT. INSTALLATION SHOULD NOT BE STARTED UNTIL THE ENTIRE INSTRUCTION BOOK HAS BEEN REVIEWED AND UNDERSTOOD. FAILURE TO FOLLOW THE FULL INSTRUCTIONS CAN RESULT IN DEATH, SEVERE PERSONAL INJURY, OR PROPERTY DAMAGE.

**⚠ WARNING**

THESE QUICK START INSTRUCTIONS ARE PROVIDED FOR USE ONLY BY TECHNICIANS HIGHLY FAMILIAR AND EXPERIENCED WITH ATC-100 CONTROLLED ATS EQUIPMENT INSTALLATION, SET UP, AND TESTING. IT IS STRONGLY SUGGESTED THAT THE FULL INSTRUCTIONS BE FOLLOWED FOR ALL INSTALLATIONS, SET UP, AND TESTING.

**Step 1:** Mount the ATS on a flat rigid surface (Figure 15). Shim if necessary.

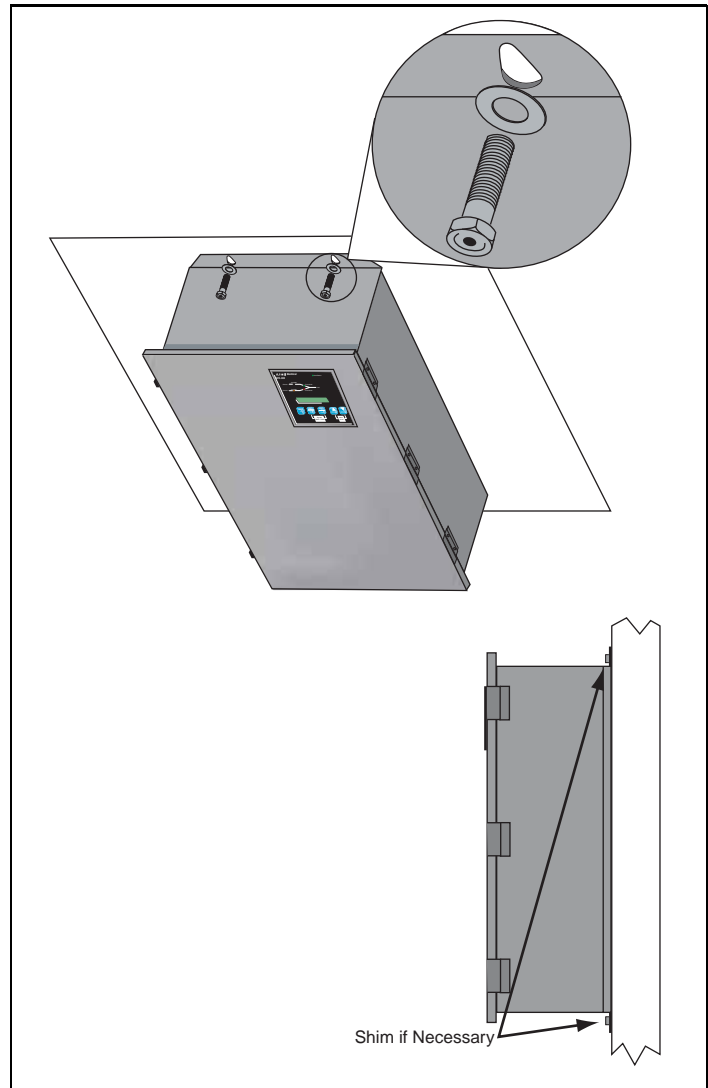

**Figure 15. Mounting Details.**

**Step 2:** Install the power cables. Cables must be sized and installed per National Electrical Code, refer to NFPA70. The cables must be sized within the specified cable size range on the side of the cable connectors.

Connect the cables and torque to the correct value indicated on the label on the door in the following order:

1. Load Cables\* (T1, T2, T3);
2. Utility or Utility Supply (N1, N2, N3); and
3. Generator or Generator Supply (E1, E2, E3).

For 4 pole transfer switches, connect the load cables (TN), Utility or utility supply (NN), and Generator or generator supply (EN). Refer to Figure 16 for the location of all parts discussed in this document.

\* Load cables **MUST** be connected and torqued **BEFORE** installing the **SUPPLY** cables (Figure 16).



Figure 16. 400 A, 2-Pole, ATS Interior Components.

ATC-100 Contactor Based Transfer Switch

- Step 3:** Turn the generator OFF at the generator control panel. This will prevent unexpected activation of the generator.
- Step 4:** Connect the Engine Generator Start wires to terminals 1 and 2 or 2 and 3 on the J-5 connector on the ATC-100 Controller (Figure 17). This contact is CLOSED (when the controller sends the command for the engine to start. N. O. becomes N. C. and N. C. becomes N. O.. The cus-

tomer chooses the appropriate contact for their engine start circuit.) whenever the engine generator is needed, and should be connected to a generator controller. **NEVER** connect directly to a starter solenoid or ignition system. See the Genset manufacturer instruction leaflet for recommended wire sizes and location procedures

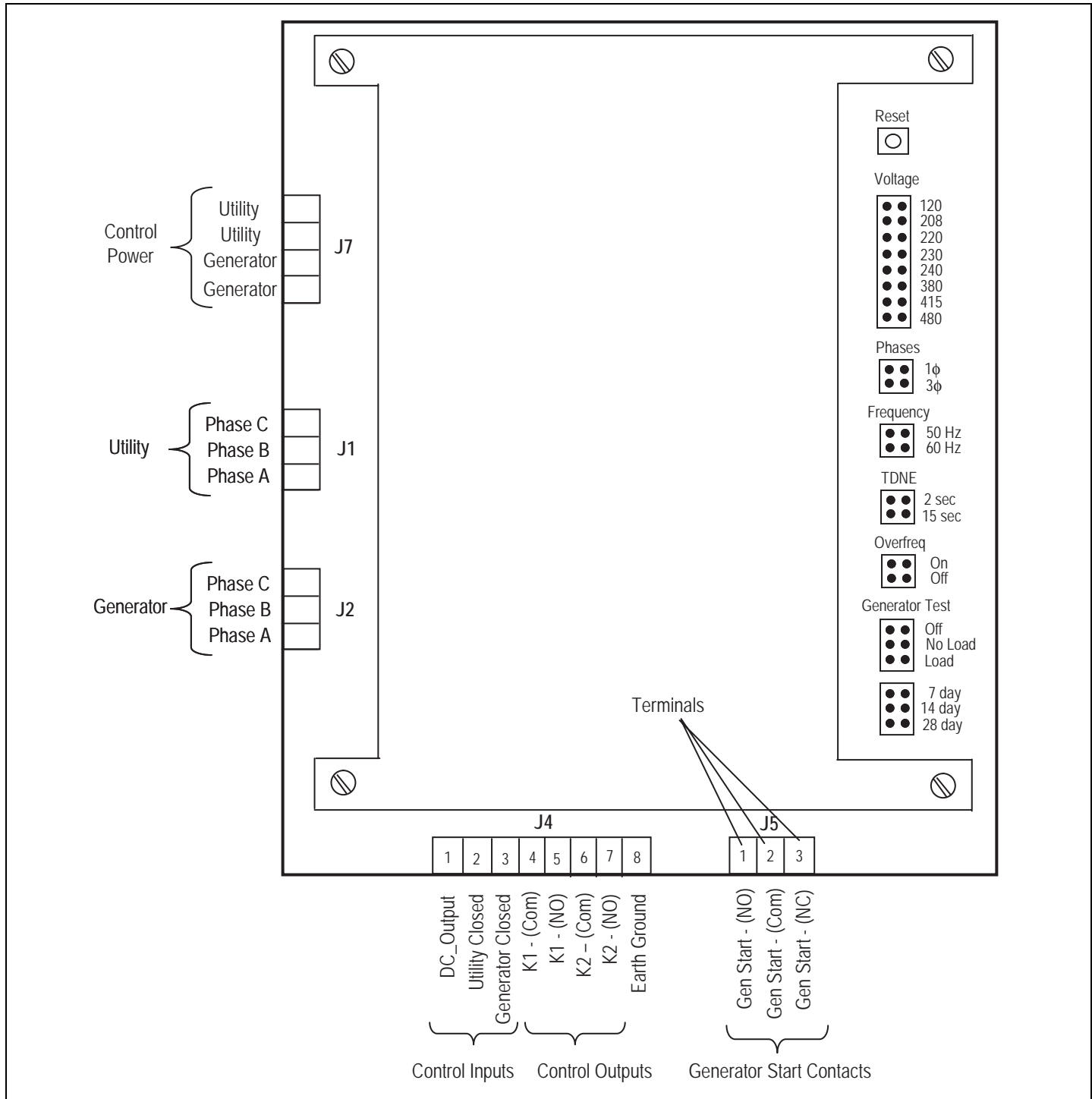

Figure 17. Engine Generator Control Connection.

**ATC-100 Contactor Based Transfer Switch**

Step 5: Apply Utility power. If the switch is properly applied for the system voltage ordered, the Utility Available white LED should light (Figure 18). Using a voltmeter, check for proper system voltage on Utility and load terminals. Voltage measurements should be taken phase to phase and phase to neutral.

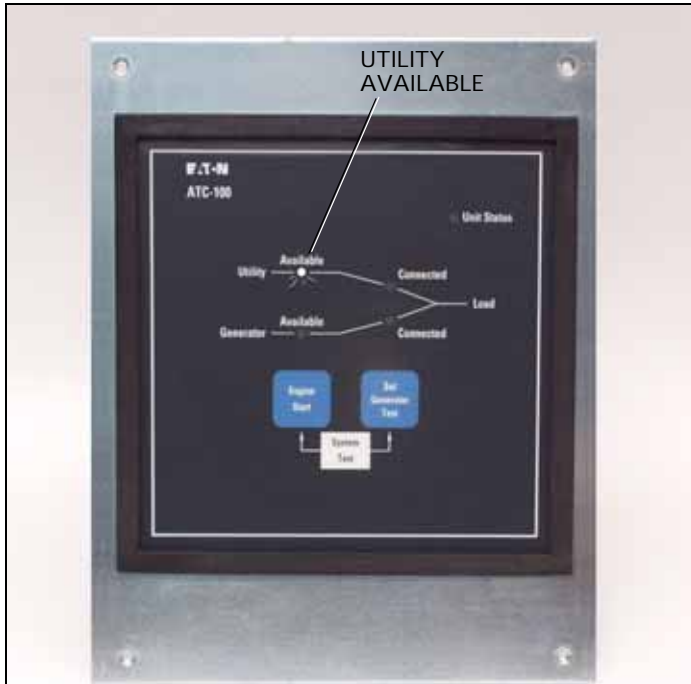

Figure 18. ATC-100 Logic (Utility Supplying Load).

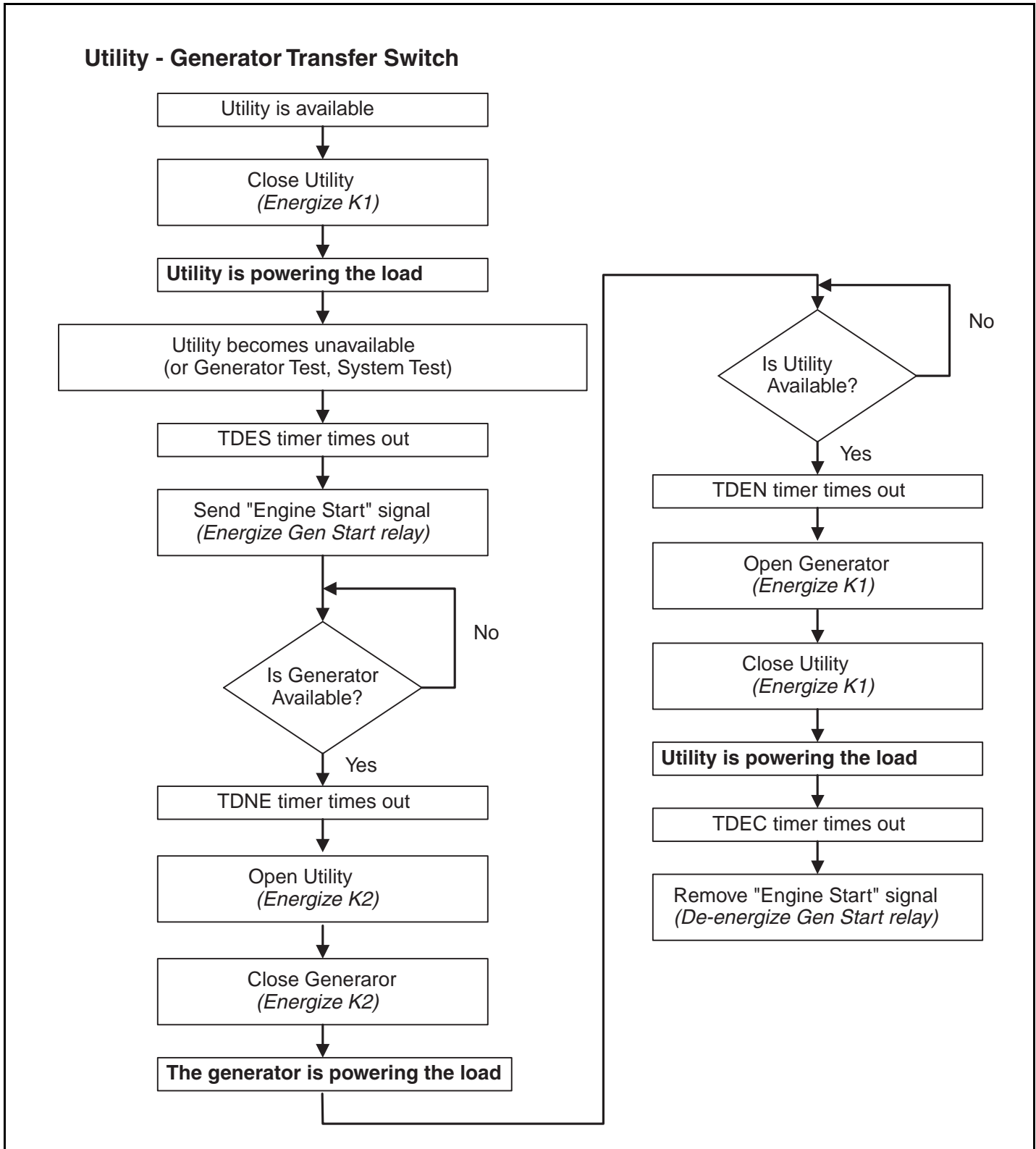

Figure 19. Utility - Generator Transfer Switch.

**ATC-100 Contactor Based Transfer Switch**

**Table 5. Adjustable Features and Setpoints**

SETPOINT	FIXED/ ADJUSTABLE	SETPOINT UNITS	DESCRIPTION	RANGE	FACTORY DEFAULT
TDES	Fixed	Minutes: Seconds	Time Delay Engine Start	3 seconds	3 seconds
TDNE	Adjustable	Minutes: Seconds	Time Delay Normal to Emergency	2 or 15 seconds	15 seconds
TDEN	Fixed	Minutes: Seconds	Time Delay Emergency to Normal	5 minutes	5 minutes
TDEC	Fixed	Minutes: Seconds	Time Delay Engine Cool-off	1 minute	1 minute
NOM FREQ	Adjustable	Hertz	Nominal Frequency	50 or 60 Hz	As ordered
NOM VOLTS	Adjustable	Volts	Nominal Voltage	120, 208, 220, 230, 240, 380, 415, and 480 volts	As ordered
S1 UV DROP	Fixed	Volts	Utility Undervoltage Dropout	80% of NOMV	80% of NOMV in volts
S2 UV DROP	Fixed	Volts	Generator Undervoltage Dropout	80% of NOMV	80% of NOMV in volts
S1 UV PICK	Fixed	Volts	Utility Undervoltage Pickup	90% of NOMV	90% of NOMV in volts
S2 UV PICK	Fixed	Volts	Generator Undervoltage Pickup	90% of NOMV	90% of NOMV in volts
S2 UF DROP	Fixed	Hertz	Generator Underfrequency Dropout	90% of NOMF	90% of NOMF in hertz
S2 UF PICK	Fixed	Hertz	Generator Underfrequency Pickup	95% of NOMF	95% of NOMF in hertz
S2 OF DROP	Fixed	Hertz	Generator Overfrequency Dropout	115% of NOMF	115% of NOMF in hertz
S2 OF PICK	Fixed	Hertz	Generator Overfrequency Pickup	110% of NOMF	110% of NOMF in hertz
Generator Test	Adjustable		Generator Test Programming	7-DAY, 14-DAY or 28 DAY	7-DAY
TEST MODE	Adjustable		Test Mode	No Load, Load, OFF	OFF
TER	Fixed	Minutes	Engine run test time	15 minutes	15 minutes
PHASES	Adjustable		3-phase or single phase	1 or 3	AS ORDERED
TDEF	Fixed	Seconds	Time Delay Emergency Fail Timer	6 seconds	6 seconds

See tables in the appendix for Voltage and Frequency Pickup and Dropout settings.

**Step 6:** To change a setpoint (adjustable features), access the rear of the controller and move the yellow jumpers to the desired location.

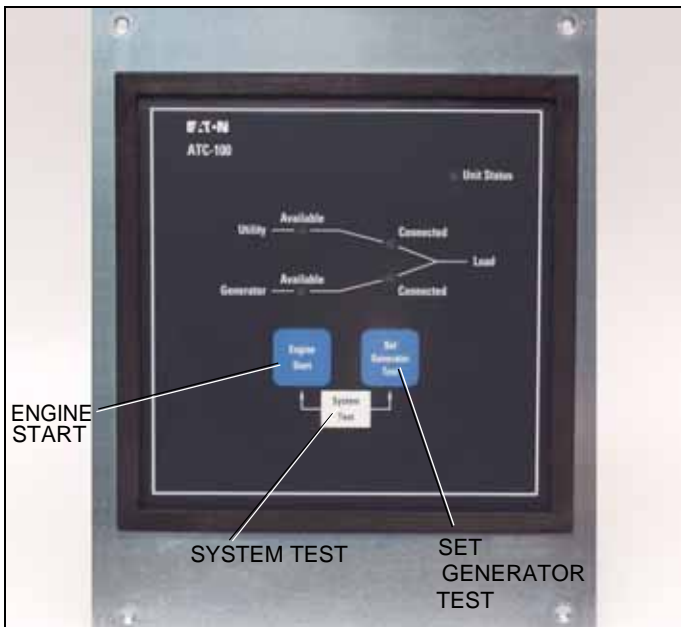

**Figure 20. ATC-100.**

**! WARNING**

**THE GENERATOR SHOULD BE MANUALLY STARTED AND THE OUTPUT CHECKED AND VERIFIED BEFORE PROCEEDING TO STEP 7. IF IMPROPER VOLTAGE/FREQUENCY IS APPLIED TO THE LOAD, THE ATS MAY BE DAMAGED.**

**Step 7:** Manually start the engine generator at the generator controller. Check that the generator is running and the *Generator Available* amber LED is lit. If the LED is lit, shut down the generator and place the Genset controller in the Auto-operating position. If the LED is not lit, the setpoints should be reviewed and the generator checked for proper voltage and frequency output.

**Step 8:** Initiate a System Test from the front panel of the ATC-100 (Figure 20). This may be done by pressing and holding the “Engine Start” and “Set Generator Test” buttons simultaneously for 5 seconds.

The generator should start, the ATS should transfer and run on the generator for the set test interval, then proceed to a TDEN countdown and return to the utility. While the ATS is connected to the Generator, use a voltmeter to check for correct system voltage on the load terminals of the ATS. Voltage measurements should be taken phase to phase and phase to neutral. A load test will cause a momentary power outage during transfer.

- Step 9:** ATC1 Power Failure Test - Initiate a Load Test by simulating an actual power failure.
1. This should be done by opening the upstream breaker or fused disconnect switch.
  2. The generator should start and the ATS should transfer to the Generator.
  3. After transfer, close the upstream breaker, or close the Utility Control Circuit Fused Disconnect. The TDEN timer should begin counting, and, when complete, the ATS should transfer to the Utility. The TDEC should time out and shut the Generator power unit down.

### NOTICE

WHILE PERFORMING TESTING, IF AN UNDESIRE OR UNDOCUMENTED RESULT OCCURS, FIRST CONTACT THE LOCAL GENSET DEALER. IF THE RESULT IS NOT CORRECTED, CONTACT THE EATON POWER QUALITY SUPPORT CENTER AT 1-800-354-2070.

---

**APPENDIX A: Pickup / Dropout Tables**

UNDERVOLTAGE PICKUP / DROPOUT TABLE

PERCENTAGE	VOLTAGE								
	120	208	220	230	240	380	415	480	
90	108	187	198	207	216	342	374	432	Pickup
80	96	166	176	184	192	304	332	384	Dropout

UNDERFREQUENCY PICKUP / DROPOUT TABLE

PERCENTAGE	FREQUENCY		
	50	60	
95	48	57	Pickup
90	45	54	Dropout

OVERFREQUENCY PICKUP / DROPOUT TABLE

PERCENTAGE	FREQUENCY		
	50	60	
115	58	69	Dropout
110	55	66	Pickup

**Notes:**

Notes:

This instruction booklet is published solely for information purposes and should not be considered all-inclusive. If further information is required, you should consult an authorized Eaton sales representative.

The sale of the product shown in this literature is subject to the terms and conditions outlined in appropriate Eaton selling policies or other contractual agreement between the parties. This literature is not intended to and does not enlarge or add to any such contract. The sole source governing the rights and remedies of any purchaser of this equipment is the contract between the purchaser and Eaton.

NO WARRANTIES, EXPRESSED OR IMPLIED, INCLUDING WARRANTIES OF FITNESS FOR A PARTICULAR PURPOSE OR MERCHANTABILITY, OR WARRANTIES ARISING FROM COURSE OF DEALING OR USAGE OF TRADE, ARE MADE REGARDING THE INFORMATION, RECOMMENDATIONS, AND DESCRIPTIONS CONTAINED HEREIN. In no event will Eaton be responsible to the purchaser or user in contract, in tort (including negligence), strict liability or otherwise for any special, indirect, incidental or consequential damage or loss whatsoever, including but not limited to damage or loss of use of equipment, plant or power system, cost of capital, loss of power, additional expenses in the use of existing power facilities, or claims against the purchaser or user by its customers resulting from the use of the information, recommendations and description contained herein.

Eaton Electrical Inc.  
1000 Cherrington Parkway  
Moon Township, PA 15108-4312  
USA  
tel: 1-800-525-2000  
[www.eatonelectrical.com](http://www.eatonelectrical.com)

