



Powering Business Worldwide

O & M Manual for ATC-300 2-Position Contactor Based Transfer Switch

Instruction Booklet

<i>Description</i>	<i>Page</i>
Introduction	2
Receiving, Handling, and Storage	6
Equipment Description	7
Installation and Wiring	14
Operation	20
Testing and Problem Solving	21
Adjustments	23
Maintenance	23
Renewal Parts Guide	24
ATC-300 Contactor Based ATS Quick Start Instructions	25
Appendix A: Pickup / Dropout Tables	35

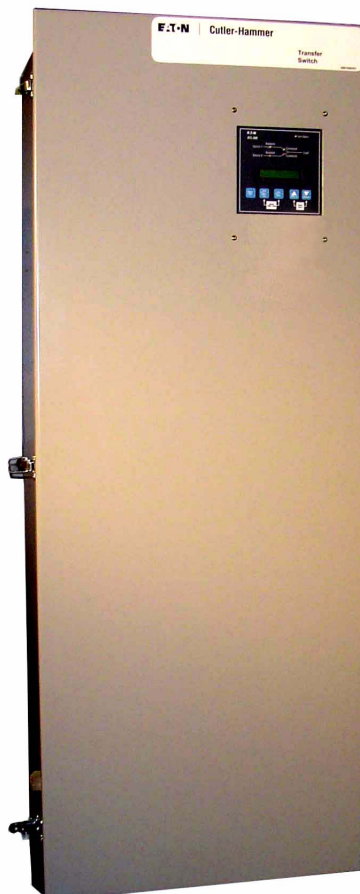



WARNING

READ AND UNDERSTAND THE INSTRUCTIONS CONTAINED HEREIN AFTER BEFORE ATTEMPTING TO UNPACK, ASSEMBLE, OPERATE, OR MAINTAIN THIS EQUIPMENT.

HAZARDOUS VOLTAGES ARE PRESENT INSIDE TRANSFER SWITCH ENCLOSURES THAT CAN CAUSE DEATH OR SEVERE PERSONAL INJURY. FOLLOW PROPER INSTALLATION, OPERATION, AND MAINTENANCE PROCEDURES TO AVOID THESE VOLTAGES.

TRANSFER SWITCH EQUIPMENT COVERED BY THIS INSTRUCTION BOOK IS DESIGNED AND TESTED TO OPERATE WITHIN ITS NAMEPLATE RATINGS. OPERATION OUTSIDE OF THESE RATINGS MAY CAUSE THE EQUIPMENT TO FAIL RESULTING IN DEATH, SERIOUS BODILY INJURY, AND/OR PROPERTY DAMAGE. ALL RESPONSIBLE PERSONNEL SHOULD LOCATE THE DOOR MOUNTED EQUIPMENT NAMEPLATE AND BE FAMILIAR WITH THE INFORMATION PROVIDED ON THE NAMEPLATE. A TYPICAL EQUIPMENT NAMEPLATE IS SHOWN IN FIGURE 1.

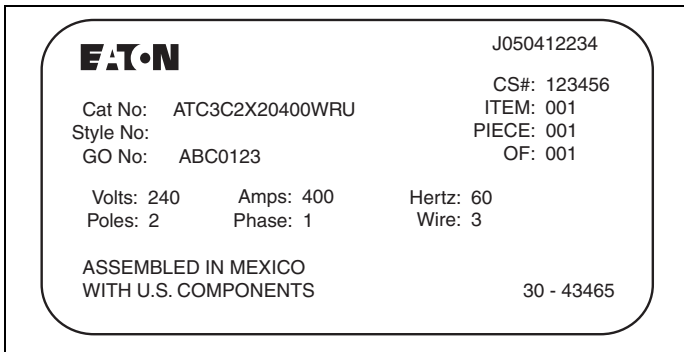

Figure 1. Typical Automatic Transfer Switch (ATS) Equipment Nameplate.

All possible contingencies that may arise during installation, operation, or maintenance, and all details and variations of this equipment do no purport to be covered by these instructions. If further information is desired by the purchaser regarding a particular installation, operation, or maintenance of particular equipment, please contact an authorized Eaton Sales Representative or the installing contractor.

Section 1: Introduction

1.1 Preliminary Comments and Safety Precautions

This technical document is intended to cover most aspects associated with the installation, application, operation, and maintenance of the Automatic Transfer Controller (ATC-300) controlled contactor based ATS with ratings from 40 through 400 amperes (A). It is provided as a guide for authorized and qualified personnel only. Please refer to the specific WARNING and CAUTION in Section 1.1.2 before proceeding. If further information is required by the purchaser regarding a particular installation, application, or maintenance activity, please contact an authorized Eaton sales representative or the installing contractor.

1.1.1 Warranty and Liability Information

No warranties, expressed or implied, including warranties of fitness for a particular purpose of merchantability, or warranties arising from course of dealing or usage of trade, are made regarding the information, recommendations and descriptions contained herein. In no event will Eaton be responsible to the purchaser or user in contract, in tort (including negligence), strict liability or otherwise for any special, indirect, incidental or consequential damage or loss whatsoever, including but not limited to damage or loss of use of equipment, plant or power system, cost of capital, loss of power, additional expenses in the use of existing power facilities, or claims against the purchaser or user by its customers resulting from the use of the information and descriptions contained herein.

1.1.2 Safety Precautions

All safety codes, safety standards, and/or regulations must be strictly observed in the installation, operation, and maintenance of this device.



WARNING

THE WARNINGS AND CAUTIONS INCLUDED AS PART OF THE PROCEDURAL STEPS IN THIS DOCUMENT ARE FOR PERSONAL SAFETY AND PROTECTION OF EQUIPMENT FROM DAMAGE. AN EXAMPLE OF A TYPICAL WARNING LABEL HEADING IS SHOWN ABOVE TO FAMILIARIZE PERSONNEL WITH THE STYLE OF PRESENTATION. THIS WILL HELP TO INSURE THAT PERSONNEL ARE ALERT TO WARNINGS, WHICH APPEAR THROUGHOUT THE DOCUMENT. IN ADDITION, WARNINGS AND CAUTIONS ARE ALL UPPER CASE AND BOLDFACE.



CAUTION

COMPLETELY READ AND UNDERSTAND THE MATERIAL PRESENTED IN THIS DOCUMENT BEFORE ATTEMPTING INSTALLATION, OPERATION, OR APPLICATION OF THE EQUIPMENT. IN ADDITION, ONLY QUALIFIED PERSONS SHOULD BE PERMITTED TO PERFORM ANY WORK ASSOCIATED WITH THIS EQUIPMENT. ANY WIRING INSTRUCTIONS PRESENTED IN THIS DOCUMENT MUST BE FOLLOWED PRECISELY. FAILURE TO DO SO COULD CAUSE PERMANENT EQUIPMENT DAMAGE.

1.2 General Information

Transfer switches are used to protect critical electrical loads against loss of power. The load's Source 1 power source is backed up by a Source 2 power source. A transfer switch is connected to both the Source 1 and Source 2 power sources and supplies the load with power from one of the two sources. In the event that power is lost from Source 1, the transfer switch transfers the load to the Source 2 power source. This transfer is automatic. Once Source 1 power is restored, the load is automatically transferred back to the Source 1 power source (Figure 2).

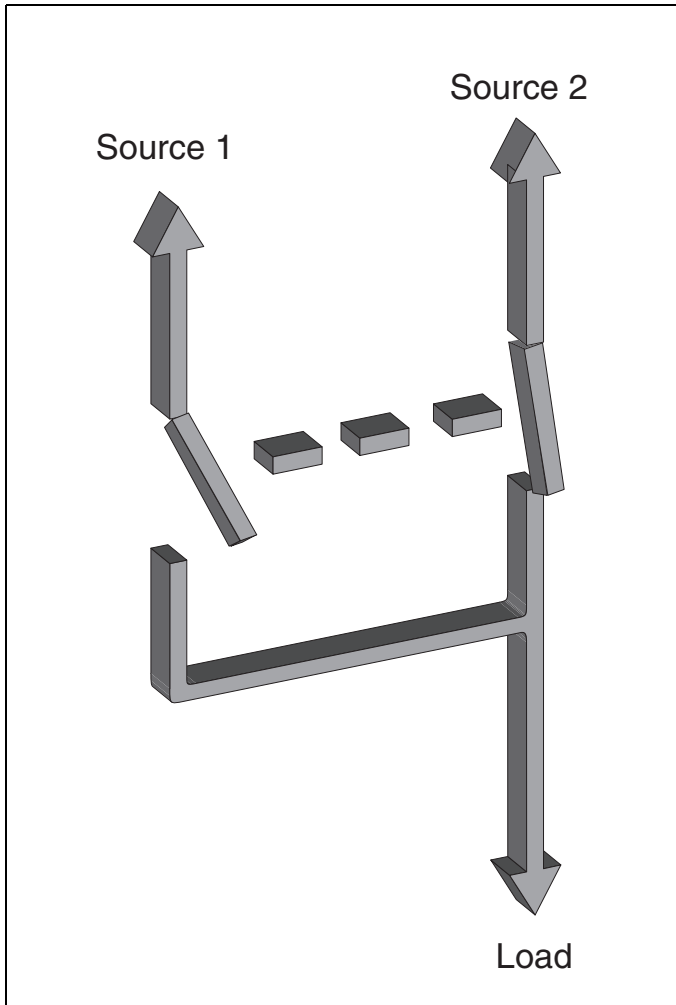

Figure 2. Typical Load Transfer Switch Schematic (Contactor Type).

In ATS equipment, the switch's intelligence system initiates the transfer when the Source 1 power fails, falls below, or rises above a preset voltage. If the Source 2 power source is a standby generator, the ATS initiates generator startup and transfers to the Source 2 power source when sufficient generator voltage is available. When Source 1 power is restored, the ATS automatically transfers back and initiates generator shutdown. In the event the Source 1 power source fails and the Source 2 power source does not appear, the ATS remains connected to the Source 1 power source until the Source 2 power source does appear. Conversely, if connected to the Source 2 power source

and the Source 2 power source fails while the Source 1 power source is still unavailable, the ATS remains connected to the Source 2 power source.

ATSs automatically perform the transfer function and include three basic elements:

1. A power contactor to connect and disconnect the load to and from either power source.
2. Solenoids to make the transfer of the main contacts from source to source.
3. Intelligence/supervisory circuits to constantly monitor the condition of the power sources and thus provide the intelligence necessary for the switch and related circuit operation.

1.2.1 Design Configuration

The Eaton contactor based ATS is a compact design that uses a power contactor to transfer essential loads from one power source to another (Figure 3 [100A]).



Figure 3. Typical Power Panel for a 100A Model.

The Eaton contactor based ATS was designed with easy installation and simplified maintenance in mind. Three main panels comprise the contactor based ATS design:

1. Power panel;
2. Voltage selection and transformer panel (if required); and
3. Microprocessor-based logic panel.

ATC-300 2-Position Contactor Based Transfer Switch



Figure 4. Contactor Based ATS (100A).

Each panel is independently mounted with interconnecting wiring terminated at the connector receptacles on the ATC-300 Controller. Door or individual panel removal is achieved without disturbing critical connections by removing the connectors from the receptacles and cutting the wire ties that secure the wires to the door.

Mounting the enclosure is simple using top and bottom mounting flanges with elongated (teardrop) mounting holes. These mounting holes, along with power panel positioning bolts and pre-tapped inserts, insure proper power panel mounting after the initial enclosure installation. Refer to Section 4 for specific mounting and modification details.

Table 1. Withstand Ratings.

UL 1008 WITHSTAND AND CLOSE-ON RATINGS (KA)

UL 1008 Ampere Rating	480 Volts		600 Volts	
	Any Breaker	Specific Breaker	Any Breaker	Specific Breaker
100	10,000	30,000	10,000	22,000
200	10,000	30,000	22,000	35,000
260	30,000	50,000	-	-
320	30,000	50,000	-	-
400	30,000	50,000	-	-

1.3 ATS Catalog Number Identification

Transfer switch equipment catalog numbers provide a significant amount of relevant information that pertains to a particular piece of equipment. The Catalog Number Identification Table (Table 2) provides the required interpretation information. An example is offered here to initially simplify the process.

Example: Catalog Number (circled numbers correspond to position headings in Table 2).

① to ② ③ ④ ⑤ to ⑥ ⑦ ⑧ ⑨ to ⑫ ⑬ ⑭ ⑮
 AT C 3 C2 X 2 0400 W R U

The catalog number ATC3C2X20400WRU describes an ATS with a 2 pole, 2 position Power Contactor mounted on a baseplate within the enclosure. The intelligence represented by the logic panel is ATC-300 controller. The continuous current rating of this equipment is 400A and applicable at 240 Vac, 60 Hz. The transfer switch equipment is enclosed in a NEMA 3R enclosure and is listed for UL applications.

Table 2. Transfer Switch Catalog Number Explanation

POSITIONS 1 TO 2 BASIC DEVICE		POSITION 3 SWITCHING DEVICE	POSITION 4 CONTROL PANEL	POSITIONS 5 TO 6 SWITCHING DEVICE			
Automatic Transfer Switch	AT	Contactor	C	ATC-300 Controller	3	2 Position Power Contactor	C2
POSITION 7 SWITCHING DEVICE ARRANGEMENT	POSITION 8 NUMBER OF POLES	POSITIONS 9 TO 12 AMPERE RATING	POSITION 13 VOLTAGE/ FREQUENCY	POSITION 14 ENCLOSURE		POSITION 15 LISTING	
Fixed Mount	Two (2)	40A – 0040	208 Vac/60 Hz	B	Type 1	S	UL/CSA Listing
	Three (3)	80A – 0080	220 Vac/50 Hz	G	Type 12	J	No Listing
	Four (4)	100A – 0100	240 Vac/60 Hz	W	Type 3R	R	
		150A – 0150	380 Vac/50 Hz	H	Open	K	
		*200A – 0200	415 Vac/50 Hz	O			
		*225A – 0225	480 Vac/60 Hz	X			
		*260A – 0260	600 Vac/60 Hz	E			
	*400A – 0400						

*For 200A to 400A, 600 Vac application, please refer to IBO1602024E

1.4 Environmental Conditions

1.4.1 Operational Conditions

Normally, an ATS is applied indoors in an electrical equipment room. In the appropriate enclosure, it can be used for outdoor applications where the equipment is subject to falling rain, freezing temperatures, and no greater than 90% humidity (non-condensing). The ambient temperature range for operation is between -20 and 70°C (-4 to 158°F).

1.5 Glossary

With respect to their use within this document and as they relate to transfer switch and controller operation, the following terminology is defined.

Available

A source is defined as “available” when it is within its undervoltage/overvoltage/ underfrequency/overfrequency (if applicable) setpoint ranges for the nominal voltage and frequency setting.

Connected

Connected is defined as when the input is shorted by an external contact or connection.

Failed or Fails

A source is defined as “failed” when it is outside of the applicable voltage and frequency setpoint ranges for the nominal voltage and frequency setting for a time exceeding 0.5 seconds after the time delay emergency fail (TDEF) time delays expires.

Failsafe

Failsafe is a feature that prevents disconnection from the only available power source and also forces a transfer or re-transfer operation to the only available power source.

Re-Transfer

Re-transfer is defined as a change of the load connection from the Source 2 to the Source 1.

Source 1

Source 1 is the primary source (normal source, normal power source, or normal).

Source 2

Source 2 is the secondary source (emergency source, emergency power source, emergency, standby, or backup source).

Source 1: Failed or Fails

Source 1 is defined as “failed” when it is outside of its undervoltage/overvoltage/ underfrequency/overfrequency (if applicable) setpoint ranges for the nominal voltage and frequency setting.

Source 2: Failed or Fails

Source 2 is defined as “failed” when it is outside of its undervoltage/overvoltage/ underfrequency/overfrequency (if applicable) setpoint ranges for the nominal voltage and frequency setting for a time exceeding 0.5 seconds after the Time Delay Emergency Fail (TDEF) time delay expires.

Transfer

Transfer is defined as a change of the load connection from the Source 1 to the Source 2 power source.

Unconnected

Unconnected is defined as when the input is not shorted by an external contact or connection.

Section 2: Receiving, Handling, and Storage

2.1 Receiving

Every effort is made to ensure that the ATS equipment arrives at its destination undamaged and ready for installation. Packing is designed to protect internal components as well as the enclosure. Care should be exercised, however, to protect the equipment from impact at all times. Do not remove the protective packaging until the equipment is ready for installation.

When the ATS equipment reaches its destination, the customer should inspect the shipping container for any obvious signs of rough handling and/or external damage that occurred during transportation. Record any external and internal damage for reporting to the transportation carrier and Eaton, once a thorough inspection is complete. All claims should be as specific as possible and include the catalog and General Order numbers.

A shipping label affixed to the shipping container includes a variety of equipment and customer information, such as General Order Number and catalog numbers. Make certain that this information matches other shipping paper information.

Each transfer switch is packed securely with appropriate shipping materials to prevent damage during shipment. Do not remove or discard the packing material until the equipment is ready for installation.

Once the top packaging is removed from the shipment, the enclosure door can be opened. A plastic bag of documents will be found in the enclosure, usually attached to the inside of the enclosure. Important documents, such as test reports, wiring diagrams, and appropriate instruction leaflets, are enclosed within the bag and should be filed in a safe place.

2.2 Handling

As previously mentioned, ATS equipment is packaged for forklift movement. Protect the equipment from impact at all times and DO NOT double stack.

Once the equipment is at the installation location and ready to be installed, packaging material can be removed and discarded. Once the enclosure is unbolted from the wooden pallet, it can be hand moved to its installation position. Be careful not to damage the top or bottom enclosure mounting flanges. Refer to Section 4 of this manual for specific installation instructions.

2.3 Storage

Although well packaged, this equipment is not suitable for outdoor storage. The equipment warranty will not be applicable if there is evidence of outdoor storage. If the equipment is to be stored indoors for any period of time, it should be stored with its protective packaging material in place. Protect the equipment at all times from excessive moisture, construction dirt, corrosive conditions, and other contaminants.

It is strongly suggested that the package-protected equipment be stored in a climate-controlled environment with temperatures from -30 to 85°C (-22 to 185°F) and with a relative humidity of 80% or less. DO NOT, under any circumstance, stack other equipment on top of a transfer switch equipment enclosure, whether packaged or not.

Section 3: Equipment Description

3.1 General

The ATS consists of three basic panels:

1. The power panel;
2. The voltage selection and transformer panel (if required); and
3. The microprocessor-based logic panel.

These panels are interconnected via connector plugs and mounted in an enclosure (Figure 5).



Figure 5. Three Basic Panels of the ATS (40-400A).

3.2 Power Panel

The power panel is used for making load, power, and neutral connections. The power contactor is mounted on a steel baseplate (Figure 6).

3.2.1 Main Contacts

This ATS incorporates a power contactor. The main contacts connect and disconnect the load to and from the different power sources. The power contactor is mechanically and electrically interlocked to prevent the two sets of main contacts from being closed simultaneously.



Figure 6. Typical Power Panel for 40-400A Models.

3.3 Voltage Selection

3.3.1 Standard Voltage Selection (208, 240, 480, 600, 60 Hz and 220, 380, 415, 50 Hz.)

The Standard voltage selection panel consists of multi-tap transformers, contained in a steel case mounted in the enclosure (Figure 7). The voltage is selected by simply removing the wires from the default primary taps of both transformers and installing them on the primary taps for the desired voltage. Taps are provided for 208 to 600 Vac to satisfy application voltage. The factory default position is 600 Vac.

CAUTION

WHEN CHANGING THE SELECTED VOLTAGE, THE POWER MUST BE REMOVED FROM THE ATS AND THE WIRES MUST BE MOVED ON THE TAPS OF BOTH TRANSFORMERS.

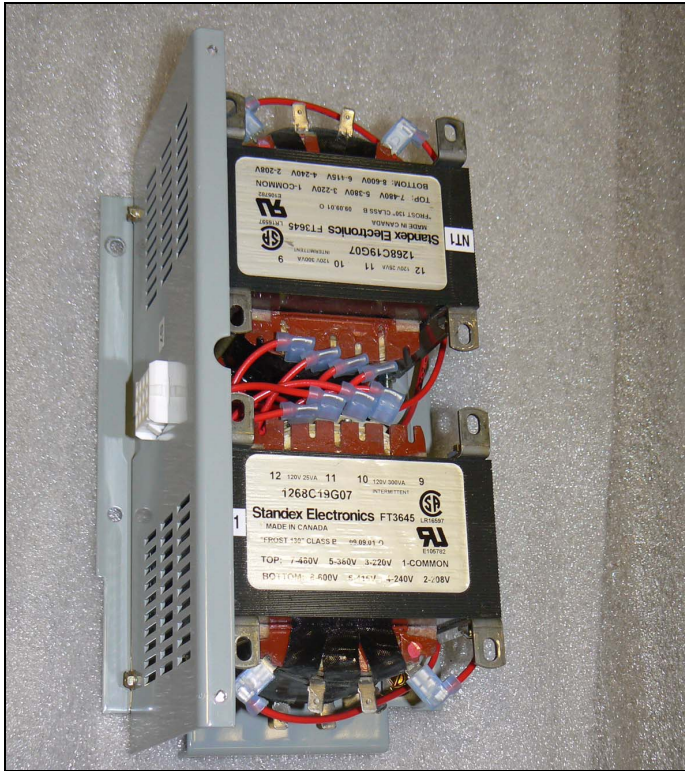

Figure 7. Standard Voltage Selection Terminals (Shown Connected to the 480 Vac Taps).

3.4 ATC-300 Logic Panel

The ATC-300 is a microprocessor-based transfer switch logic control package. The hardware and software of the controller contain the intelligence/supervisory circuits that constantly monitor the condition of the power sources. It provides the intelligence necessary for the operation of the ATS (Figure 8).

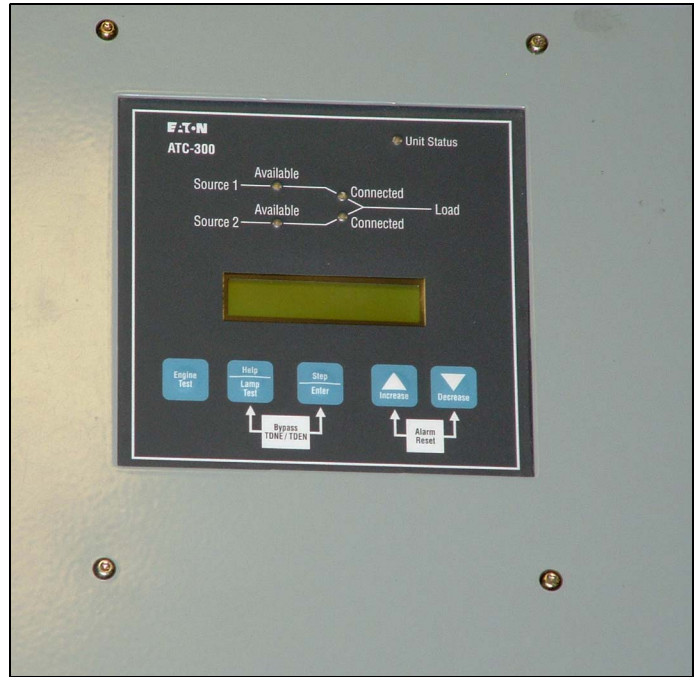

Figure 8. ATC-300 Logic Control Panel.

The ATC-300 controller has an operating temperature of -20 to 70°C (-4 to 158°F).

The controller circuit board is protected by an insulating conformal coating.

The specifications, under normal operating conditions, are as follows:

- Tolerance for voltage sensing function: $\pm 1\%$ of full scale
- Tolerance for frequency sensing function: ± 0.3 Hz of setting

3.5 Features

A variety of standard and optional features are available for Eaton ATCs. **All features or combinations of features may not be available on specific ATCs.** All features and/or accessories are Underwriters Laboratories (UL) listed unless noted.

3.5.1 Standard Features

The following is a list of the standard features for the ATC-300 Controlled ATS.

1. Time Delay Normal to Emergency (TDNE)

This feature provides a time delay when transferring from the Source 1 to the Source 2 power source. Timing begins when Source 2 becomes available. It permits controlled transfer of the load circuit to Source 2.

Adjustable 0 - 1800 Seconds

2. Time Delay on Engine Starting (TDES)

This feature provides a time delay of the signal to initiate the engine/generator start cycle in order to override momentary power outages or voltage fluctuations of Source 1.

Adjustable 0 - 120 Seconds

3. Time Delay Emergency to Normal (TDEN)

This feature provides a time delay of the re-transfer operation to permit stabilization of Source 1. Timing begins when Source 1 becomes available. If Source 2 fails during timing, then re-transfer is immediate overriding the time delay.

Adjustable 0 - 1800 Seconds

4. Time Delay for Engine Cool-down (TDEC)

This feature provides a time delay of the signal to initiate the engine/generator stop cycle after the re-transfer operation. This allows the engine/generator to cool down by running unloaded. Timing begins on completion of the re-transfer cycle.

Adjustable 0 - 1800 Seconds

5. Source 2 Monitoring and Protection

This feature provides monitoring and protection based on the Source 2 voltage and/or frequency setpoints. All feature 5 functions are Failsafe operations.

5B. 1-Phase Undervoltage and Underfrequency Protection

Adjustable Undervoltage:

Dropout: 78 - 97% of nominal

Pickup: (Dropout + 2%) to 99% of nominal

Adjustable Underfrequency:

Dropout: 90 - 97% of nominal

Pickup: (Dropout + 1Hz) to 99% of nominal

5C. 1-Phase Overvoltage/Overfrequency

Adjustable Overvoltage:

Dropout: 105 - 110% of nominal

Pickup: 103% to (Dropout - 2%) of nominal

Adjustable Overfrequency:

Dropout: 103 - 105% of nominal

Pickup: 101% to (Dropout - 1Hz) of nominal

5D. 1-Phase Undervoltage

Adjustable Undervoltage:

Dropout: 78 - 97% of nominal

Pickup: (Dropout + 2%) to 99% of nominal

5E. 1-Phase Overvoltage

Adjustable Overvoltage:

Dropout: 105 - 110% of nominal

Pickup: 103% to (Dropout - 2%) of nominal

5F. 3-Phase Undervoltage

Adjustable Undervoltage:

Dropout: 78 - 97% of nominal

Pickup: (Dropout + 2%) to 99% of nominal

5G. 3-Phase Overvoltage

Adjustable Overvoltage:

Dropout: 105 - 110% of nominal

Pickup: 103% to (Dropout - 2%) of nominal

5H. Phase Reversal

For a 3-phase wye source, this feature monitors the phase sequence of the sources. If a source does not have the same ABC or CBA sequence as the setpoint value, that source will be considered "Unavailable."

For a 3-phase delta source, this feature should be turned off via the PHASE REV setpoint.

5J. All Phase Undervoltage and Underfrequency Protection

Adjustable Undervoltage:

Dropout: 78 - 97% of nominal

Pickup: (Dropout + 2%) to 99% of nominal

Adjustable Underfrequency:

Dropout: 90 - 97% of nominal

Pickup: (Dropout + 1Hz) to 99% of nominal

5K. All Phase Overvoltage/Overfrequency

Adjustable Overvoltage:

Dropout: 105 - 110% of nominal

Pickup: 103% to (Dropout - 2%) of nominal

Adjustable Overfrequency:

Dropout: 103 - 105% of nominal

Pickup: 101% to (Dropout - 1Hz) of nominal

5L. Source 2 3-Phase Voltage Unbalance

For a 3-phase wye source, this feature monitors phase voltage ratios. Voltage unbalance (%) is calculated as the difference between the maximum and minimum phase voltage, divided by the minimum phase voltage. User-selectable setpoints are available for dropout and pickup unbalance settings (minimum 2% differential). Dropout is adjustable from 5 to 20%. Pickup is adjustable from 3 to (Dropout -2%). A setpoint for user-selectable time delay from 10 to 30 seconds is provided. The factory default setpoints are: 5% dropout, 3% pickup, and 30 seconds time delay. A user-selectable setpoint for enable and disable is also provided.

When an unbalance condition is detected on Source 2, the Unbalance Timer (TD UNBAL) starts timing. After TD UNBAL times out, Source 2 is declared "failed".

For a 3-phase delta source, this feature should be turned off via the VOLT UNBAL setpoint.

6. Test Operators

Eaton ATs are provided with a Test Pushbutton that simulates a loss of the Source 1 power source as standard (Feature 6B). All programmed time delays (TDNE, TDEN, etc.) will be performed as part of the Test. Engine run time of the Test is equal to the Plant Exerciser (Feature 23) programmed setpoint. All Tests are Failsafe protected.

6B. Test Pushbutton

Programmable setpoints include:

1. Load or No Load Testing, or Disabled
2. Engine run time equal to the plant exerciser (Feature 23) setting

7. Time Delay Emergency Fail (TDEF)

This feature provides a time delay that prevents a connected Source 2 power source from being declared "Failed" in order to override momentary generator fluctuations. If the Source 2 power source remains in the failed state then, 0.5 seconds after the TDEF timer expires, the transfer switch will proceed with the programmed sequence for retransfer. This time delay is only implemented when the Source 2 power source is a generator.

Adjustable 0 - 6 Seconds

8. Time Delay Bypass Pushbutton

This feature provides a way (by pushing the Help and Step pushbutton simultaneously) to bypass the TDNE (Feature 1) and/or TDEN (Feature 2) time delays. The Time Delay Bypass function, when activated by pushing the Help and Step pushbutton simultaneously, will reduce any or all of the programmed time delay to zero.

8C. Bypass TDEN

This feature provides one set of pushbuttons to bypass the TDEN time delay.

8D. Bypass TDNE

This feature provides one set of pushbuttons to bypass the TDNE time delay.

12. Power Source Annunciation

This feature provides LEDs to give switch position and power source availability indications.

Switch Position

Provides LEDs to indicate the switch position

12C. Source 1 - Source Connected

This feature provides a green LED that, when lit, indicates the load is connected to Source 1.

12D. Source 2 - Source Connected

This feature provides a red LED that, when lit, indicates the load is connected to Source 2.

Power Source Availability

Provides LEDs to indicate if a power source is available. LEDs may be integral or separate from the controller.

12G. Source 1 - Available

This feature provides a white LED that, when lit, indicates Source 1 is available.

12H. Source 2 - Available

This feature provides an amber LED that, when lit, indicates Source 2 is available.

14. Relay Auxiliary Contacts

14G. Source 1 Present: Provides two (2) normally open and two (2) normally closed contacts. The relay is energized when Source 1 is available.

14H. Source 2 Present: Provides two (2) normally open and two (2) normally closed contacts. The relay is energized when Source 2 is available.

15. Switch Position Indication Contact

This feature provides a contact that indicates if the power switching device is in the "Open" or "Closed" position.

15E. Source 1 Position Indication Contact

This feature provides 1 dry form "C" contact that indicates the position of the Source 1 power switching device.

15F. Source 2 Position Indication Contact

This feature provides 1 dry form "C" contact that indicates the position of the Source 2 power switching device.

23. Plant Exerciser (PE)

This feature provides a means for automatic testing of the engine generator set or standby power system. All programmed time delays will be performed during plant exerciser operations.

23K. Plant Exerciser Selectable – Disabled/1/7/14/28 Day Interval

This feature provides for automatic test operation of the generator. Available test cycles are daily, 7, 14, or 28 days with duration equal to the programmed engine test time.

Programmable setpoints allow for selection of three test cycles:

- Engine Start/Run Only (No Load);
- Exercise with Load Transfer; or
- Disabled

This is a “Failsafe” operation.

26. Source 1 - Monitoring and Protection

This feature provides Source 1 monitoring and protection functions. If the Source 1 power supply fails, then the Automatic Transfer Controller will begin the sequence of operations necessary to transfer the load circuit to the Source 2 power supply. All Feature 26 monitoring and protection functions are Failsafe operations.

26D. Go to Source 2

This feature provides the capability for an external contact opening to initiate a load circuit transfer to the Source 2 power source. This includes starting the engine/generator, performing the programmed time delays, and the transfer operation. Re-transfer will occur when the external contact is closed or under a Failsafe condition.

26H. Phase Reversal Protection

For a 3-phase wye source, this feature monitors the phase sequence of the sources. If a source does not have the same ABC or CBA sequence as the phase reversal setpoint, the source will be considered “Unavailable”.

For a 3-phase delta source, this feature should be turned off via the PHASE REV setpoint.

26J. All Phase Undervoltage and Underfrequency Protection

Adjustable Undervoltage:

Dropout: 78 - 97% of nominal

Pickup: (Dropout + 2%) to 99% of nominal

Adjustable Underfrequency:

Dropout: 90 - 97% of nominal

Pickup: (Dropout + 1Hz) to 99% of nominal

26K. All Phase Overvoltage/Overfrequency

Adjustable Overvoltage:

Dropout: 105 - 110% of nominal

Pickup: 103% to (Dropout – 2%) of nominal

Adjustable Overfrequency:

Dropout: 103 - 105% of nominal

Pickup: 101% to (Dropout -1Hz) of nominal

26L. Source 1 3-Phase Voltage Unbalance

.For a 3-phase wye source, this feature monitors phase voltage ratios. Voltage unbalance (%) is calculated as the difference between the maximum and minimum phase voltage, divided by the minimum phase voltage. User-selectable setpoints are available for dropout and pickup unbalance settings (minimum 2% differential). Dropout is adjustable from 5 to 20%. Pickup is adjustable from 3 to (Dropout – 2%). A setpoint for user-selectable time delay from 10 to 30 seconds is provided. The factory default setpoints are: 5% dropout, 3% pickup, and 30 seconds time delay. A user-selectable setpoint for enable and disable is also provided.

When an unbalance condition is detected on Source 1, the Unbalance Timer (TD UNBAL) starts timing. After TD UNBAL times out, Source 1 is declared “failed”.

For a 3-phase delta source, this feature should be turned off via the VOLT UNBAL setpoint.

32F. In Phase Transition

Provides In-Phase transition, which is a feature that will permit a transfer or re-transfer between 2 available sources that have a phase angle difference of 8 degrees or less. The In-Phase transition feature includes permissible frequency difference and synchronization time setpoints. In the event source 1 and source 2 fail to synchronize within a specified amount of time, due to excessive phase angle difference or frequency difference, then the transfer will take place under delayed transition. Alarm relay will energize and failure will be logged into the transfer history as either “Sync Fail – Freq” or “Sync Fail – Phase” depending on whether the frequency difference or the phase difference was excessive. The adjustable frequency difference is 0.0 to 3.0 Hz. If the synchronization does not occur within a specified amount of time, the Alarm relay will energize and the failure will be logged into the Transfer History as either “Sync Fail - Freq” or “Sync Fail - Phase” depending on whether the frequency difference or the phase difference was excessive.

35. Pre-Transfer Signal

This feature provides a signal to a remote device prior to a re-transfer operation. It provides one Form “C” contact (NO/NC) for interface with other equipment (typically elevator controls). The contacts close/open on a timed basis prior to transfer in either direction. After TDNE/TDEN times out, this relay closes and the Pre-transfer Timer (TPRE) starts timing. After the TPRE times out, the transfer proceeds by starting the TDN timer if enabled. The pre-transfer relay opens after the transfer is complete.

Adjustable 0 - 120 Seconds

35A. Pre-Transfer Signal with 1 N.O. and 1 N.C. Contacts

This feature provides pre-transfer signal and includes 1 N.O. and 1N.C. contacts.

42. Seismic Withstand Capability

Provides transfer switch with seismic capability exceeding the worst case Zone 4 required per both the Uniform Building Code and the California Building Code.

3.5.2 Optional Features

The following is a list of the optional features for the ATC-300 Controlled ATS. **All features or combinations of features may not be available on specific ATs**

9B. Maintenance Selector Switch (MSS)

Marked "OFF", "ON". This feature provides selector switch disconnection of control to transfer thus allowing testing of the transfer switch control logic circuitry without initiating load transfer. Positioning the MSS in the "OFF" position isolates the control circuit, permitting manual operation of the transfer switch or testing of logic circuitry without load transfer.

14. Relay Auxiliary Contacts: This feature provides form "C" relay auxiliary contacts.

14C. Source 1 Present: Provides four (4) normally open and four (4) normally closed contacts. The relay is energized when Source 1 is available.

14D. Source 2 Present: Provides four (4) normally open and four (4) normally closed contacts. The relay is energized when Source 2 is available.

15. Switch Position Indication Contact

This feature provides a contact that indicates if the power switching device is in the "Open" or "Closed position.

15G. Source 1 Position Indication Contact

This feature provides 3 Dry Form "C" contacts that indicate the position of the Source 1 power-switching device.

15H. Source 2 Position Indication Contact

This feature provides 3 Dry Form "C" contacts that indicate the position of the Source 2 power-switching device.

18. Metering

This feature includes all required external devices (CTs, shorting blocks, fuses, etc.) for a fully functional metering system.

18O. IQ Analyzer Normal (S1) Only

18P. IQ Analyzer Emergency (S2) Only

18Q. IQ Analyzer Normal (S1) & Emergency (S2) Switch Selectable

18V. IQ Analyzer Load

18R. IQ DP-4000 Normal (S1) Only

18S. IQ DP-4000 Emergency (S2) Only

18T. IQ DP-4000 Normal (S1) & Emergency (S2) Switch Selectable

18U. IQ DP-4000 Load

18AN. IQ 250/260 Normal (S1) Only

18AE. IQ 250/260 Emergency (S2) Only

18AL. IQ 250/260 Load

18W. Ammeter

A single ammeter is a true RMS sensing device that displays single phase current only.

The ammeter can be mounted on Source 1, Source 2, or load. The meter can also be configured for 1, 2, or 3-phase sensing by supplying one meter per phase for Source 1, Source 2, or load. Ammeters for both Source 1 and Source 2 can also be grouped together.

23L. 24 Hour, 7day, 365 Day Programmable Plant Exerciser

This plant exerciser has two channel electronic time switches with 365-day, 7-day, 24-hour programming. Each channel can be independently programmed and can provide up to 400 events. The plant exerciser offers daily, weekly or annual programming capability with up to 99 separate holiday periods of any duration and priority. An LCD display indicates load status, time-of-day, weekday and date.

29G. Auto/Manual Operation

This feature provides 2-position auto/manual selector switch marked "Auto/Manual" which permits the selection of automatic or manual operation. Once the selector switch is transferred to manual mode, manual transfer between Normal (S1) and Emergency (S2) can be achieved by operating another 2-position selector switch marked "Normal-Emergency".

38. Stainless Steel Logic Cover

38A. Stainless Steel Cover for Device Panel

Provides an added level of security by providing a pad lockable stainless steel cover for use with standard transfer switch device panel. The cover is designed for NEMA 1, 3R, 4X, and 12 applications.

38B. Stainless Steel Cover for Controller

Provides an added level of security by providing a pad lockable stainless steel cover for use with standard transfer switch logic controllers and/or associated device panels. These covers function with Eaton's ATC series logic controllers and device panels. The covers are designed for NEMA 1, 3R, 4X, and 12 applications.

41. Space Heater With Thermostat

This feature provides a space heater and non-adjustable thermostat. External control power is not required.

41A. Space Heater With Thermostat - 100 Watt

This feature provides a 100 watt (W) space heater with a non-adjustable thermostat.

49B. Sensing Isolation Transformer (Up to 600 VAC only)

This feature provides 3-phase, 4-wire for Source-1 and Source-2 sensing input on ATC controller for a high resistance grounded delta system.

51D1. 50kA CVX Surge Device

This feature gives protection for surge current capacity rating 50kA, upto 480VAC by providing a low impedance surge path to ground while supporting rated voltage. It provides LED indication.

51F1. 100kA CVX Surge Device

This feature gives protection for surge current capacity rating 100kA, upto 480VAC by providing a low impedance surge path to ground while supporting rated voltage. It provides LED indication.

3.6 Enclosure

The rugged steel ATS enclosure is supplied with three door hinges, regardless of enclosure size. They ensure proper support of the door and door mounted devices (Figure 9). The hinges have removable hinge pins to facilitate door removal. Certain procedures, such as switch mounting, are simplified with the door removed. The doors are supplied as standard with pad-lockable latches.



Figure 9. Typical Type 1 Enclosure (Door Closed).

The door is used to mount a variety of lights, switches, and push-buttons, depending upon the options required for a particular ATS. All lights and switches are mounted in the plastic door-mounted panel.

The rear of the enclosure is supplied with teardrop shaped holes in the top and bottom mounting flanges to facilitate mounting. It is also supplied with two positioning bolts and various pre-tapped inserts to insure proper positioning of the power panel anytime the power panel must be repositioned to accommodate a different cable entry position. Cable entry holes are the responsibility of the customer.

ATS enclosures and all internal steel mounting plates, such as the power panel mounting plate, go through a pretreatment cleaning system prior to painting to ensure a durable finish.

The standard ATS enclosure is NEMA 1 Type for general use. However, a variety of enclosures are available to address almost any environmental circumstance (see Table 3).

Table 3. Transfer Switch Equipment Enclosures

NEMA TYPE	DESIGN	PROTECTION
Open	Indoor	
1	Indoor	Enclosed Equipment
3R	Outdoor	Rain, Ice Formation
12	Indoor	Dust, Dirt, and Non-Corrosive Liquids

3.7 Standards

Eaton ATS equipment, enclosed in any of the enclosures listed in Table 3, is listed for application by UL and ULC. In addition, Eaton ATSs are listed in File E38116 by Underwriters Laboratories, Inc. under Standard UL 1008. This standard covers requirements for automatic transfer switches intended for use in ordinary locations to provide lighting and power as follows:

- a. In emergency systems, in accordance with articles 517 and 700 in the National Electrical Code, ANSI/ NFPA 70, and the National Fire Protection Association No. 76A; and/or
- b. In standby systems, in accordance with article 702 of the National Electrical Code; and/or
- c. In legally required standby systems in accordance with article 701 of the National Electrical Code.

Eaton ATSs are available to meet NFPA 110 for emergency and standby power systems, and NFPA 99 for health care facilities when ordered with the appropriate options.

Standard UL 1008 for ATSs lists devices under the reexamination program which only require a continual physical reexamination of the components used in the product to ensure consistency with the originally submitted device. Follow-up testing is not required by UL 1008.

Section 4: Installation and Wiring

4.1 General

Eaton ATCs are factory wired and tested. Installation requires solidly mounting the enclosed unit and connecting power cables and auxiliary pilot circuits. Physical mounting procedures and power cable connections are covered in this section. All other required wiring or electrical connection references are covered in a separate Customer Wiring Booklet packaged with the ATC.

Locate the wiring schematic, review it, and keep it readily available for reference purposes during installation and testing. Once an ATC is properly installed and wired, it should be mechanically and electrically checked for proper installation and operation. The procedures for these initial mechanical and electrical checks are outlined in Section 6 of this instruction manual.

WARNING

BE CERTAIN THAT THE SOLID STEEL DOOR IS PROPERLY INSTALLED BEFORE THE TRANSFER SWITCH EQUIPMENT IS PUT INTO SERVICE. THE DOOR PROVIDES PROTECTION FROM DANGEROUS VOLTAGES AT THE LINE AND LOAD TERMINALS WHEN THE EQUIPMENT IS IN OPERATION. FAILURE TO DO SO COULD RESULT IN PERSONAL INJURY OR DEATH.

4.2 Mounting Location

Choose a location that offers a flat, rigid mounting surface capable of supporting the weight of the enclosed ATC equipment. For standard ATCs, avoid locations that are moist, hot, or dusty. However, Eaton offers optional enclosure designs that can be used in special environments. If there are any doubts as to a location's suitability, discuss them with your Eaton representative.

Check to make certain that there are no pipes, wires, or other mounting hazards in the immediate mounting area that could create a problem.

Carefully remove all packing material from the ATC at the mounting location. Even though an equipment inspection should have been made when the equipment was received, make another careful inspection of the enclosure and the enclosed ATC components as the packing material is removed and the enclosure readied for mounting. Be especially alert for distorted metal, loose wires, or damaged components.

4.3 Mounting Procedure

CAUTION

SINCE THE ENCLOSED ATC MUST BE LIFTED INTO PLACE FOR MOUNTING, BE CERTAIN THAT ADEQUATE RESOURCES ARE AVAILABLE FOR LIFTING TO AVOID PERSONNEL INJURIES OR EQUIPMENT DAMAGE.

All equipment enclosures and power panels are of the same design. Only the overall physical dimensions change. Note that the enclosure is provided with four teardrop (elongated) mounting holes, two in the top mounting flange and two in the bottom.

Cable entry holes are not part of the enclosure when shipped from the factory and must be provided in the field, either before or after mounting the enclosure. Cable access may be from the top, bottom, and/or side.

CAUTION

EXTREME CARE SHOULD BE TAKEN TO PROTECT THE TRANSFER SWITCH FROM DRILL CHIPS, FILINGS, AND OTHER CONTAMINANTS WHEN MAKING THE CABLE ENTRY HOLES. EXTREME CARE SHOULD ALSO BE TAKEN WHEN MOUNTING THE ENCLOSURE TO PREVENT COMPONENT DAMAGE OR A FUTURE MALFUNCTION.



Figure 10. Typical (40A-400A) Contactor Based ATC Equipment (Door Open).

With the enclosed ATS equipment unpacked and ready for mounting, proceed with the following steps.

- Step 1:** The ATS enclosure door is hinge mounted with removable hinge pins. To simplify the mounting procedure and avoid damaging the door-mounted logic panel, it is strongly suggested that the door be carefully removed and put it in a safe place until mounting is complete. To remove the door, open the door and disconnect the connectors at the back of the ATC-300 logic panel. Remove the wire ties securing the harness to the inside of the door. Carefully remove the hinge pins then the door from the enclosure.
- Step 2:** Install the required upper and lower mounting bolt anchors and the two upper mounting bolts in the mounting surface.
- Step 3:** Gently lift the enclosure and guide the teardrop holes in the upper mounting flange over the upper mounting bolts. Do not completely tighten the bolts at this time.
- Step 4:** While still supporting the enclosure, install the two lower mounting bolts in the lower mounting flange. Again, do not completely tighten the bolts at this time. Use shims, if required, to prevent deformation of the enclosure if the mounting surface is distorted.
- Step 5:** Tighten all four mounting bolts after any required shimming is completed.

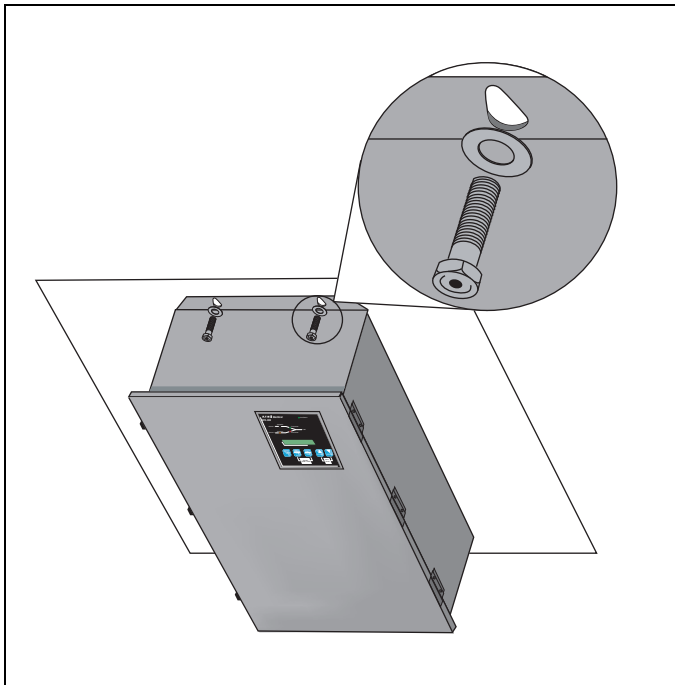

Figure 11. Typical Mounting of the ATS to a Mounting Surface.

- Step 6:** Double check to ensure that all packing and shipping materials have been removed.

4.4 Power Cable Connections

WARNING

POWER CONDUCTORS MAY HAVE VOLTAGE PRESENT THAT CAN CAUSE SEVERE PERSONAL INJURY OR DEATH. DE-ENERGIZE ALL POWER OR CONTROL CIRCUIT CONDUCTORS TO BE CONNECTED TO THE ATS EQUIPMENT BEFORE BEGINNING TO WORK WITH THE CONDUCTORS AND/OR TERMINATING THEM TO THE EQUIPMENT.

CAUTION

USE OF CABLE LUGS NOT DESIGNED FOR THE ATS MAY CAUSE HEATING PROBLEMS.

CAUTION

TO HELP PREVENT COMPONENT DAMAGE OR FUTURE MALFUNCTIONS, USE EXTREME CARE TO KEEP CONTAMINANTS OUT OF THE ATS EQUIPMENT WHEN MAKING POWER CABLE CONNECTIONS.

CAUTION

RUN THE POWER CABLE THROUGH THE GUTTER SPACE PROVIDED TO THE RIGHT OR LEFT OF POWER PANEL.

Test all power cables prior to connection to the unit to ensure that the conductors or cable insulation have not been damaged while being pulled into position.

Power cables are to be connected to solderless screw type lugs located on the ATS switching devices. Refer to the separate Customer Wiring Booklet supplied with the ATS equipment for power termination. Verify that the lugs supplied will accommodate the power cables being used. Also verify that the cables comply with local electrical codes. Standard ATS equipment, as supplied from the factory, will accommodate the wire sizes shown in Table 4.

Carefully strip the insulation from the power cables to avoid nicking or ringing of the conductor strands. Prepare the stripped conductor termination end by cleaning it with a wire brush. If aluminum conductors are used, apply an appropriate joint compound to the clean conductor surface area.

WARNING

IMPROPER POWER CABLE CONNECTIONS CAN CAUSE EXCESSIVE HEAT AND SUBSEQUENT EQUIPMENT FAILURE.

Tighten the cable lugs to the torque identified on the label affixed to the door of the unit.

Table 4. Transfer Switch Equipment Wire Sizes

TRANSFER SWITCH AMPERE RATING	WIRE SIZE RANGES	NUMBER OF CABLES PER PHASE	TERMINAL TEMPERATURE RATING °C (°F)
100	#14-2/0	1	75 (167)
200	#6-250 KCMIL	1	75 (167)
320	#4-600 KCMIL or (2) 1/0-250 KCMIL	1 or 2 - depending on wire size used	75 (167)
400	#4-600 KCMIL or (2) 1/0-250 KCMIL	1 or 2 - depending on wire size used	75 (167)
600	#2-600 KCMIL	2	75 (167)

4.5 Wiring



WARNING

POWER CONDUCTORS AND CONTROL WIRING MAY HAVE VOLTAGE PRESENT THAT CAN CAUSE SEVERE PERSONAL INJURY OR DEATH. DEENERGIZE ALL POWER OR CONTROL CIRCUIT CONDUCTORS BEFORE BEGINNING TO PERFORM ANY WIRING ACTIVITY TO OR WITHIN THE ATS EQUIPMENT.

Power sources, load conductors, and control wiring should be connected to locations as indicated in the Customer Wiring Booklet supplied with the ATS equipment.



CAUTION

ENSURE THE ATS VOLTAGE IS SET CORRECTLY. IT SHOULD BE THE SAME AS THE SOURCE 1 AND SOURCE 2 LINE VOLTAGES. OPERATING THE EQUIPMENT ON IMPROPER VOLTAGE CAN CAUSE EQUIPMENT DAMAGE.

Once the ATS equipment has been installed and wired, perform the initial mechanical and electrical procedures as outlined in Section 6 to verify that the equipment is installed and operating properly.

4.6 Engine Start Connection

The engine control contact connections are located on the logic panel of the ATS. Connect the engine start wires to the terminals marked 13 and 14 on J-5 connector on the ATC-300 Controller (see Figure 12). A contact closes between these terminal when an engine start signal is provided by the ATS logic. The wiring diagram provides additional engine start connection information. Use the proper wire size as listed by the generator set (Genset) manufacturer.

NOTICE

PRIOR TO MAKING THE ENGINE START CONNECTION TO THE SWITCH, SET THE ENGINE GENERATOR CONTROLS SELECTOR SWITCH IN THE OFF POSITION TO PREVENT AN UNWANTED ENGINE START. CONTROL WIRING, SUCH AS THE ENGINE START WIRES, MUST BE RUN IN A SEPARATE CONDUIT FROM THE POWER CABLES.

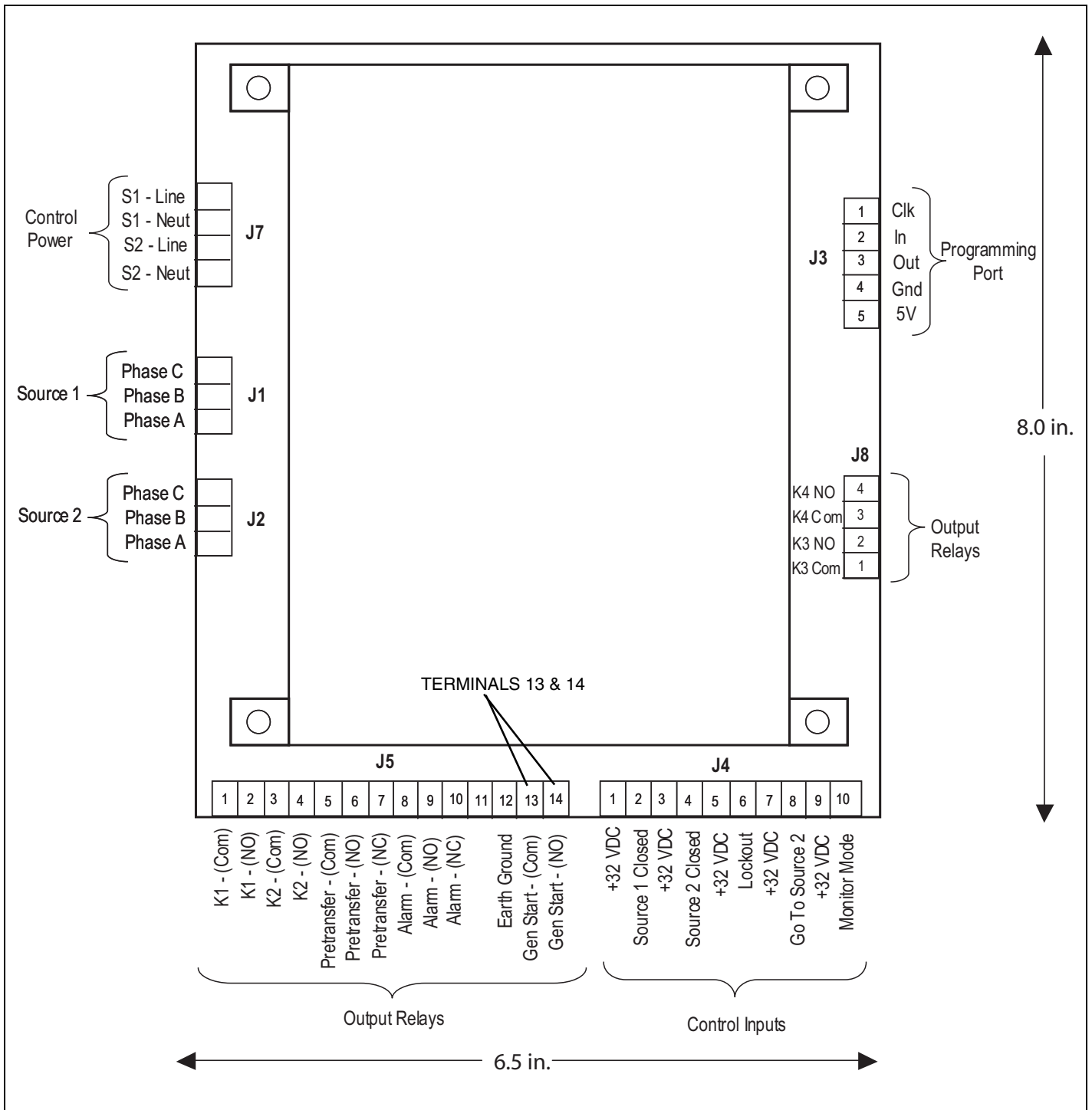

Figure 12. Location of Terminals 13 and 14 on the J-5 Connector of ATC-300 Controller.

4.7 Voltage Selection Adjustments

Certain devices, such as the Voltage Selection Panel, sensing relays, and timers, need to be set and/or calibrated prior to placing the ATS equipment in service. Adjustments for logic devices are described in the separate instructional document dedicated to the specific logic being used. Voltage selection adjustments are described in this section.

CAUTION

BE SURE THAT THE CORRECT VOLTAGE IS SELECTED TO MATCH THE SYSTEM VOLTAGE. AN IMPROPER SELECTION AND/OR CONNECTION COULD RESULT IN EQUIPMENT DAMAGE.

4.7.1 Standard Voltage Selection Panels (208, 240, 480, 600 V, - 60 Hz & 220, 380, 415 V, -50 Hz)

The Standard voltage selection panel consists of multi-tap transformers, contained in a steel case mounted in the enclosure. To change the voltage from the factory default 600 Vac, follow the steps detailed below.

Step 1: Loosen the six screws securing the cover of the Voltage Selection Transformer case. Slide the cover up, then away from the case.

Step 2: Remove the wires from the primary taps of both transformers and installed them on the taps for the desired voltage (Figure 13B). Note that only one wire per transformer is moved since the second wire is the zero reference.

CAUTION

WHEN CHANGING THE VOLTAGE, ONE WIRE MUST BE MOVED ON THE PRIMARY TAPS OF BOTH TRANSFORMERS.



Figure 13A. Standard Voltage Selection Panel.



Figure 13B. Standard Voltage Selection Panel.

Step 3: Reinstall the cover and tighten the four screws.

4.8 Terminal Block Wire Installation and Removal

Proceed with the following steps and associated figures to install or remove terminal block wiring.

Step 1: Figure 14 shows two tension clamp terminal blocks. There is a large one and small one, but the operation is the same for both. A small tool, such as a screwdriver, will be pushed into the square hole next to the wire hole and a wire will be inserted into the larger circular hole on the outer edge.

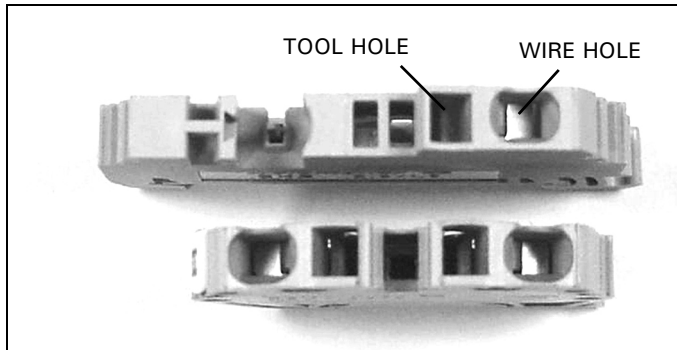

Figure 14. Tension Clamp Terminal Blocks.

Step 2: Begin by inserting a small, flathead screwdriver into the square (tool) hole with the flat surface of the screwdriver against the back wall of the hole. With a little bit of force, push the screwdriver in on a slight angle toward the center of the clamp. Be sure to slide it in until it clicks. You will then see the clamp open in the wire hole.

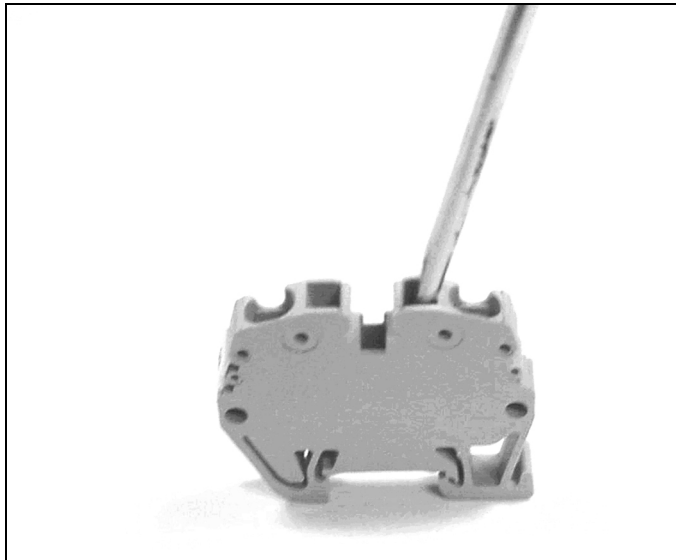

Figure 15. Screwdriver Inserted in the "Tool" Hole.

Step 3: Once the screwdriver is in place, obtain a stripped wire (strip about 1/4 in.) and insert it into the larger circular wire hole. Push the wire in until it can go no further.

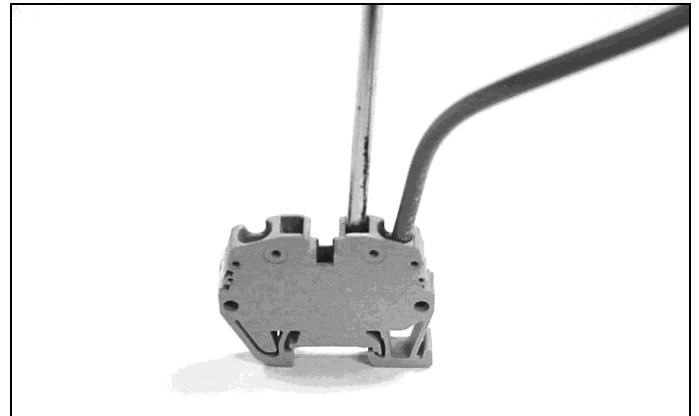

Figure 16. Wire Inserted in the "Wire" Hole.

Step 4: While holding the wire in place, pull the screwdriver out. The wire will now be held securely in the terminal block. Pull on the wire to insure that it is correctly inserted into the clamp.

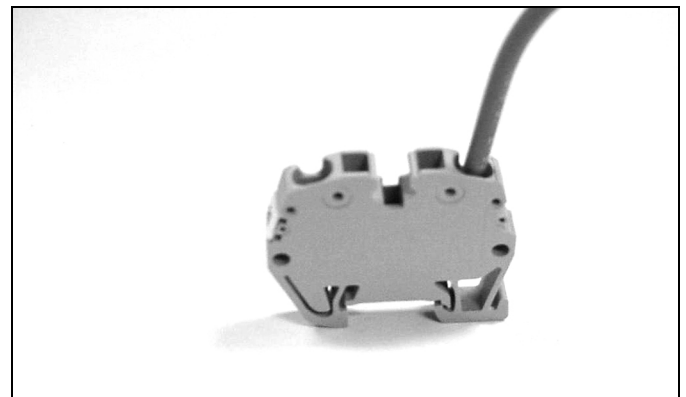

Figure 17. Wire Securely Installed in the Terminal Block.

Section 5: Operation

5.1 General

An ATS provides a power contactor to connect and disconnect the load to and from the Source 1 and Source 2 power sources (Section 3.2.1).

5.2 Manual Operation

WARNING

DO NOT ATTEMPT TO MANUALLY OPERATE THE ATS WITH SOURCE 1 OR SOURCE 2 AVAILABLE.

WARNING

HIGH VOLTAGES ARE PRESENT IN AND AROUND TRANSFER SWITCH EQUIPMENT. BEFORE ATTEMPTING TO MANUALLY TRANSFER, DISCONNECT THE LINE POWER FROM THE EQUIPMENT BEING SERVICED BY OPENING AND LOCKING OUT, IF POSSIBLE, THE NEXT HIGHEST DISCONNECT DEVICE. FAILURE TO FOLLOW THIS PROCEDURE COULD CAUSE SEVERE PERSONAL INJURY AND/OR DEATH.

ALWAYS TURN THE SOURCE 1 POWER OFF AND TURN THE SOURCE 2 (IF A GENERATOR) CONTROL SELECTOR SWITCH TO THE "OFF" POSITION BEFORE ATTEMPTING A MANUAL TRANSFER.

To manually operate:

1. Disconnect all sources of power.
2. Disconnect the J7 connector from the ATC-300 controller.
3. Locate the manual lever on the left side of the contactor.
4. Locate the handle used to manually transfer the switch.
5. Attach the handle to the manual lever.
6. Rotate the lever down to go to Source 1.
7. Rotate the lever down again to go to Source 2.

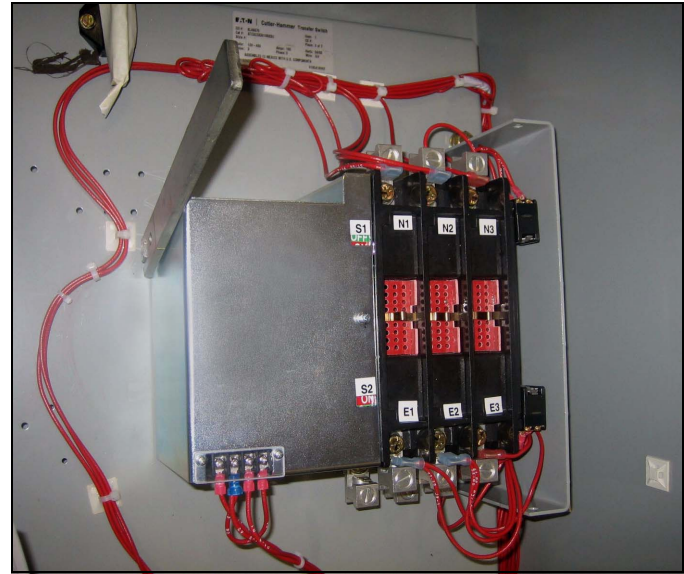

Figure 18. ATC-300 Manual Operating Handle in Use.

8. Once the manual operation is complete and automatic operation is desired, connect the sources of power.
9. Check for 120 Vac at J7-4 to J7-3 if Source 1 is available.
10. Check for 120 Vac at J7-2 to J7-1 if Source 2 is available. See the Troubleshooting Guide (Table 3, Section 7 of ATC 300 Controller Instruction Booklet IB01602009E) if values are above 130 Vac or below 110 Vac.
11. Insert the J7 connector into the controller.
12. Follow the testing procedure in Section 6 to ensure proper automatic operation.

5.3 Automatic Transfer

The operating sequence of an ATS is dictated by the switch's standard features and selected options. Operation of an ATS during Source 1 power source failure and Source 1 power source restoration will be described here with only standard options included on the switch. Additional options, as described in Section 3, can change sequences and timing, depending upon the options selected. It is strongly suggested that you become familiar with additional options selected with the particular ATS and their effect on the normal operation of an ATS.

5.3.1 Source 1 Power Source Failure

Standard Source 1 power source failure is defined as a reduction or loss of voltage. If this occurs, the sequence of operation is as follows.

1. Failure of Source 1 is detected by the controller intelligence.
2. When the controller detects a failure, the engine contacts close (after delay if programmed) and start the engine-driven generator.
3. When the Source 2 voltage reaches its operation rating, the K2 relay closes, starting the transfer operation. This operating sequence causes the contactor to open Source 1 and close on Source 2.
4. The load is now transferred to the Source 2 power source.

5.3.2 Source 1 Power Source Restoration

1. A return to the Source 1 power source begins when the voltage in all phases of a 3-phase sensing unit, or phase-to-phase in a single sensing unit, is restored to a preset value.
2. At the preset voltage, the controller will cause the K1 relay to change state. This starts the return to the Source 1 power source.
3. During this sequence, the contactor opens Source 2 and closes on Source 1.
4. Simultaneously, the engine cool-down timer initiates the shut down of the engine driven generator.
5. Transfer of the load back to the Source 1 power source is now complete.

Section 6: Testing and Problem Solving

6.1 Testing

After the ATS equipment is initially installed or during planned outages, the installation should be tested to ensure that all equipment operates properly. This attention to detail will help avoid unexpected malfunctions. Mechanical and/or electrical tests should be performed as described in this section.

The frequency of subsequent testing should be based on recommendations of the Genset manufacturer. Use the test pushbutton to check the electrical operation of the switch.



WARNING

HIGH VOLTAGES ASSOCIATED WITH OPERATIONAL TRANSFER SWITCH EQUIPMENT PRESENT A SHOCK HAZARD THAT CAN CAUSE SEVERE PERSONAL INJURY OR DEATH. USE EXTREME CAUTION TO AVOID TOUCHING ELECTRICAL CONNECTIONS WHENEVER INSPECTING OR TESTING THE EQUIPMENT.

IN ADDITION, IMPROPER OPERATION OF THE GENERATOR SET PRESENTS A HAZARD THAT CAN CAUSE SEVERE PERSONAL INJURY OR DEATH. OBSERVE ALL SAFETY PRECAUTIONS IN YOUR GENERATOR SET OPERATIONS AND INSTALLATION MANUALS.

6.1.1 Mechanical and/or Electrical Testing

NOTICE

SINCE FEATURE 4 (TIME DELAY ENGINE COOL-OFF), AS DESCRIBED IN SECTION 3, IS A STANDARD FEATURE, AN ENGINE START SIGNAL WILL BE PRESENT FOR A PERIOD OF TIME WHEN THE SWITCH IS FIRST ENERGIZED. THE PERIOD OF TIME IS EQUAL TO THE TIMER SETTING. TO AVOID STARTING THE ENGINE DURING THIS TIME PERIOD, TURN THE GENERATOR CONTROLS TO THE OFF POSITION.

Energize the ATS equipment as described in Sections 6.1.2 through 6.1.6. Insure that all safety precautions are taken and that all **WARNINGS** and **CAUTIONS** are observed.

6.1.2 No Voltage Steps

With no voltage available on either power source, proceed as follows.

- Step 1:** The generator engine start controls should be in the OFF position to prevent an undesired start.
- Step 2:** Ensure that the ATS has been set to the proper applied system voltage (See Section 4.7).
- Step 3:** Check all ATS loads to ensure that they are ready to be energized.

6.1.3 Connecting the Power Sources

- Step 1:** Close the Source 1 power source upstream protection device.
- Step 2:** Connect the engine start battery cable.
- Step 3:** With the emergency generator in the OFF position, close the Source 2 power source upstream protective device, assuming such a device used.

NOTICE

AT THIS POINT, AND PRIOR TO MAKING ANY ATTEMPT TO ENERGIZE THE ATS EQUIPMENT, THE ENGINE-DRIVEN GENERATOR SHOULD BE OPERATED. IF NECESSARY, THE VOLTAGE REGULATOR ON THE GENERATOR SHOULD BE ADJUSTED ACCORDING TO THE MANUFACTURER'S RECOMMENDATIONS. THE ATS EQUIPMENT WILL RESPOND ONLY TO THE RATED VOLTAGE AND FREQUENCY PROGRAMMED INTO THE CONTROLLER.

Step 4: Close any generator engine-start controls opened as a result of actions taken in Step 1, Section 6.1.2.

Step 5: Where required, use an accurate voltmeter to check phase-to-phase and phase-to-neutral voltages present at the transfer switch Source 1, Source 2, and/or load terminals.

6.1.4 Operational Checks

Step 1: Check to ensure that Source 1 switching device is in the CLOSED position. This should have been done in Section 6.1.3, Step 1.

Step 2: Initiate an automatic transfer operation from the Source 1 to the Source 2 power source by pressing the <Engine Test> pushbutton two times.

Note:The ATC-300 Logic Controller provides the capability to set the Engine Test function to:

- 0. No Load Engine Test;
- 1. Load Engine Test; or
- 2. Disabled.

The factory default is set to:

- 1. Load Engine Test
 - a. After the Time Delay Engine Starting (TDES) has timed out, the engine should start, run, and build up to normal voltage and frequency.
 - b. The transfer switch will transfer to the Source 2 power source after the Time Delay Normal to Emergency (TDNE) times out.

Step 3: Initiate an automatic transfer operation back to the Source 1 power source by pressing the <Engine Test> pushbutton one time.

- 1. After the Time Delay Emergency to Normal timer (TDEN) has timed out, the transfer switch will transfer back to the Source 1 power source.
- 2. The Time Delay for Engine Cool-Off (TDEC - Feature 4) will allow the engine to run unloaded for a preset time after transfer to the Source 1 power source is completed.

6.1.5 Alternate Tests

- 1. Alternate operational tests may be possible depending upon the options provided with any given ATS. Refer to the schematic diagram provided with the ATS equipment, along with the specification nameplate, to determine the exact options provided.



WARNING

DO NOT ATTEMPT TO MANUALLY OPERATE THE ATS WITH THE SOURCE 1 POWER SOURCE CONNECTED AND AVAILABLE.

DO NOT ATTEMPT TO MANUALLY OPERATE THE ATS WITH THE SOURCE 2 POWER SOURCE CONNECTED AND AVAILABLE.

6.2 Problem Solving



WARNING

HAZARDOUS VOLTAGES IN AND AROUND ATS EQUIPMENT DURING THE PROBLEM SOLVING PROCESS CAN CAUSE SEVERE PERSONAL INJURY AND/OR DEATH. AVOID CONTACT WITH ANY VOLTAGE SOURCE WHILE PROBLEM SOLVING.



WARNING

ONLY PROPERLY TRAINED PERSONNEL, FAMILIAR WITH THE ATS EQUIPMENT AND ITS ASSOCIATED EQUIPMENT, SHOULD BE PERMITTED TO PERFORM THE PROBLEM SOLVING FUNCTION. IF AN INDIVIDUAL IS NOT QUALIFIED TO PERFORM THE PROBLEM SOLVING FUNCTION, THE INDIVIDUAL SHOULD NOT ATTEMPT ANY OF THESE PROCEDURES.

A basic problem-solving effort is the first step to take prior to calling for assistance. Frequently, the effort will successfully address most problems encountered. The problem solving procedure is presented in the Troubleshooting Guide (Table 3, Section 7 of ATC 300 Controller Instruction Booklet IB01602009E). Remember, only qualified individuals familiar with the ATS equipment and the system in which it is applied should attempt these problem solving procedures.

If a problem persists after having completed the problem solving procedure, contact a Eaton representative for further assistance. When calling for assistance, the following is the minimum information required to properly address the need:

- 1. Style number of ATS, if applicable;
- 2. Catalog number of ATS;
- 3. Actual location of the ATS (type of facility, address, etc.);
- 4. Company name and name and position of individual representing company;
- 5. Basic description of the situation as it exists; and
- 6. Any results of the problem solving steps taken and/or readings taken.

Section 7: Adjustments

7.1 General

Refer to I.B. 01602009E, supplied with the ATS for ATC-300 Controller adjustments and programming.

Section 8: Maintenance

8.1 Introduction



WARNING

HIGH VOLTAGES ARE PRESENT IN AND AROUND ATS EQUIPMENT. BEFORE INSPECTING OR MAINTAINING THIS EQUIPMENT, DISCONNECT THE LINE POWER FROM, THEN LOCK OUT. IF POSSIBLE, THE NEXT HIGHEST DISCONNECT DEVICE. FAILURE TO FOLLOW THIS PROCEDURE COULD CAUSE SEVERE PERSONAL INJURY AND/OR DEATH.

In general, ATS switch equipment is designed to be relatively maintenance free under normal usage. However, because of the variability of application conditions and the importance placed on dependable operation by this type of equipment, inspection and maintenance checks should be made on a regularly scheduled basis. Since equipment maintenance will consist mainly of keeping the equipment clean, the frequency of maintenance will depend to a large extent on the cleanliness of the equipment's surroundings. If a significant amount of dust or foreign matter is present, a more frequent maintenance schedule should be followed.

It is suggested that visual inspections of the equipment be made on a regular basis, not just during scheduled periods. Always be alert for an accumulation of dirt in and around the structure; loose parts; and/or hardware, cracks, and/or discoloration to insulation; and damaged or discolored components.

8.2 Procedures

A suggested maintenance procedure is outlined in Table 5.

Table 5. Periodic Maintenance Procedures

STEP	ACTION
a. Make the ATS equipment safe for inspection and/or maintenance.	Disconnect the line power from equipment being serviced by opening the next highest disconnect device. Make certain that any accessory control power is switched off by disconnecting all control plugs.
b. Inspect the structure area for safety hazards or potential maintenance problems.	Inspect the area, especially where switching device is installed, for any safety hazards, including personnel safety and fire hazards. Exposure to certain chemical vapors can cause deterioration of electrical connections. Inspect for accumulated dirt, loose hardware, or physical damage. Examine the primary insulation for evidence of cracking or overheating. Overheating will show as discoloration, melting, or blistering of conductor insulation, or as pitting or melting of conductor surfaces due to arcing. Inspect the secondary control connections for damage and the control wiring for insulation integrity.
c. Inspect the power contactor for dust, dirt, soot, grease, moisture, or corrosion.	Remove dust, dirt, soot, grease, moisture, and corrosion contamination from the surface of the switching device using a dry soft lint-free cloth, dry soft bristle brush, and vacuum cleaner. Do not blow debris into the power contactor. If contamination is found, look for the source and fix the problem.
d. Check for material integrity, uneven wear, discoloration, or loose hardware.	Severe material cracking will require replacement and loose hardware will need to be tightened.
e. Check the terminals and connectors for looseness or signs of overheating.	Overheating will show as discoloration, melting, or blistering of the conductor insulation. Connections that do not have signs of looseness or overheating should not be disturbed.
f. Contact Inspection Procedure	Carefully remove the arc chute clips using needle nose pliers. Remove the arc chutes to inspect the contacts. Contact Eaton Care (1-877-ETN-CARE, Option-2) if the contacts have excessive wear. Reinstall the arc chutes and arc chute clips, making sure the ends of the clips are fully seated in the grooves on the barriers.
g. Exercise the power contactor if it is not often exercised while in operation. This will permit a "wiping" action by the contacts.	If the power contactor is used for frequent switching during normal operation, this step can be disregarded.
h. Return the ATS equipment to service.	Make certain all barriers are in place and doors closed. Reapply secondary and primary power.

SECTION 9: RENEWAL PARTS GUIDE

9.1 General

Refer to Figure 19 for assistance with selecting and ordering selected ATS renewal parts. For more information, please see Renewal Parts Publication (RP01603002E).

Example: To order the ATC-300 Controller for an **ATC3C2X20400WRU** transfer switch, order Catalog Number as shown in Figure 19, below.



ATC-300 Controller - 2 Position Contactor type (In-Phase) - CAT#8160A00G27	
Transformer Pack	100A, 2-Pole, 3-Pole, 4-Pole - Cat# 68B2584G04 200A, 2-Pole, 3-Pole, 4-Pole - Cat# 68B2584G04 400A, 2-Pole, 3-Pole, 4-Pole - Cat# 68C8229G01
Power Panel	100A (Domestic Switch), 480VAC, 2-Pole - Cat# 68C8471G14 100A (Domestic Switch), 480VAC, 3-Pole - Cat# 68C8471G15 100A (Domestic Switch), 480VAC, 4-Pole - Cat# 68C8471G16 100A (AG Switch), up to 240VAC, 2-Pole - Cat# 68C8471G04 100A (AG Switch), up to 240VAC, 3-Pole - Cat# 68C8471G05 100A (AG Switch), up to 240VAC, 4-Pole - Cat# 68C8471G06 200A (Domestic Switch), 480VAC, 2-Pole - Cat# 68C8471G11 200A (Domestic Switch), 480VAC, 3-Pole - Cat# 68C8471G12 200A (Domestic Switch), 480VAC, 4-Pole - Cat# 68C8471G13 200A (AG Switch), up to 240VAC, 2-Pole - Cat# 68C8471G01 200A (AG Switch), up to 240VAC, 3-Pole - Cat# 68C8471G02 200A (AG Switch), up to 240VAC, 4-Pole - Cat# 68C8471G03 400A (Domestic Switch), 480VAC, 2-Pole - Cat# 69C2951G03 400A (Domestic Switch), 480VAC, 3-Pole - Cat# 69C2951G01 400A (Domestic Switch), 480VAC, 4-Pole - Cat# 69C2951G02 400A (AG Switch), up to 240VAC, 2-Pole - Cat# 69C2951G13 400A (AG Switch), up to 240VAC, 3-Pole - Cat# 69C2951G11 400A (AG Switch), up to 240VAC, 4-Pole - Cat# 69C2951G12
Power Panel (Cont.)	100A (Domestic Switch), 600VAC, 2-Pole - Cat# 68C8471G11 100A (Domestic Switch), 600VAC, 3-Pole - Cat# 68C8471G12 100A (Domestic Switch), 600VAC, 4-Pole - Cat# 68C8471G13 200A (Domestic Switch), 600VAC, 2-Pole - Cat# 69C2951G03 200A (Domestic Switch), 600VAC, 3-Pole - Cat# 69C2951G01 200A (Domestic Switch), 600VAC, 4-Pole - Cat# 69C2951G02
Wiring Harness	AG Switch, up to 240VAC, 2-Pole - Cat# 68C8189G05 + 68C8189G06 AG Switch, up to 240VAC, 3-Pole, 1-Phase - Cat# 68C8189G05 + 68C8189G09 AG Switch, up to 240VAC, 3-Pole, 3-Phase - Cat# 68C8189G05 + 68C8189G07 AG Switch, up to 240VAC, 4-Pole - Cat# 68C8189G05 + 68C8189G08 Domestic Switch, up to 600VAC, 2-Pole - Cat# 68C8189G01 + 68C8189G04 Domestic Switch, up to 600VAC, 3-Pole - Cat# 68C8189G01 + 68C8189G02 Domestic Switch, up to 600VAC, 4-Pole - Cat# 68C8189G01 + 68C8189G02
100W Space Heater	AG Switch, up to 240VAC - Cat# 8160A41G55 Domestic Switch, up to 600VAC - Cat# 8160A41G54

Figure 19. Typical ATC-300 Controlled Contactor Based ATS.

**Section 10: ATC-300 Controlled ATS
Quick Start Instructions**

! WARNING

THESE QUICK START INSTRUCTIONS ARE NOT A COMPLETE SOURCE OF INFORMATION ON THE ATC-300 CONTROLLED ATS EQUIPMENT. INSTALLATION SHOULD NOT BE STARTED UNTIL THE ENTIRE INSTRUCTION BOOK HAS BEEN REVIEWED AND UNDERSTOOD. FAILURE TO FOLLOW THE FULL INSTRUCTIONS CAN RESULT IN DEATH, SEVERE PERSONAL INJURY, OR PROPERTY DAMAGE.

! WARNING

THESE QUICK START INSTRUCTIONS ARE PROVIDED FOR USE ONLY BY TECHNICIANS HIGHLY FAMILIAR AND EXPERIENCED WITH ATC-300 CONTROLLED ATS EQUIPMENT INSTALLATION, SET UP, AND TESTING. IT IS STRONGLY SUGGESTED THAT THE FULL INSTRUCTIONS BE FOLLOWED FOR ALL INSTALLATIONS, SET UP, AND TESTING.

Step 1: Mount the ATS on a flat rigid surface (Figure 20). Shim if necessary.

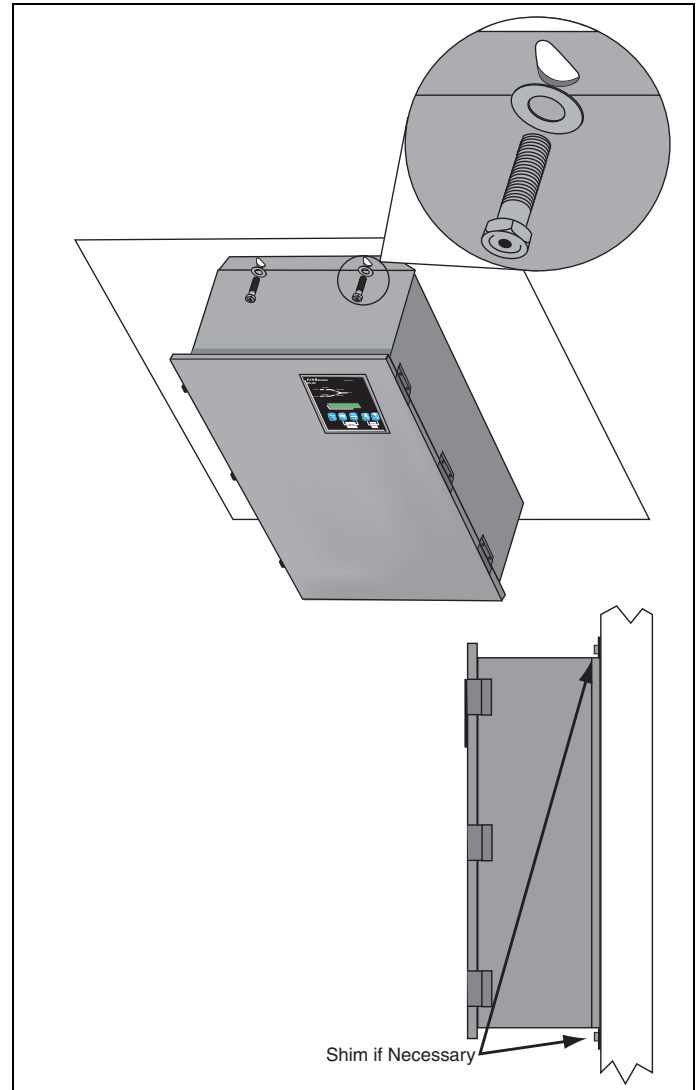

Figure 20. Mounting Details.

Step 2: Install the power cables. Cables must be sized and installed per National Electrical Code, refer to NFPA70. The cables must be sized within the specified cable size range on the side of the cable connectors.

Connect the cables and torque to the correct value indicated on the label on the door in the following order:

1. Load Cables* (T1, T2, T3);
2. Source 1 or Utility Supply (N1, N2, N3); and
3. Source 2 or Generator Supply (E1, E2, E3).

For 4 pole transfer switches, connect the load cables (TN), Source 1 or utility supply (NN), and Source 2 or generator supply (EN). Refer to Figure 21 for the location of all parts discussed in this document.

*Load cables MUST be connected and torqued BEFORE installing the SUPPLY cables (Figures 21).

ATC-300 2-Position Contactor Based Transfer Switch

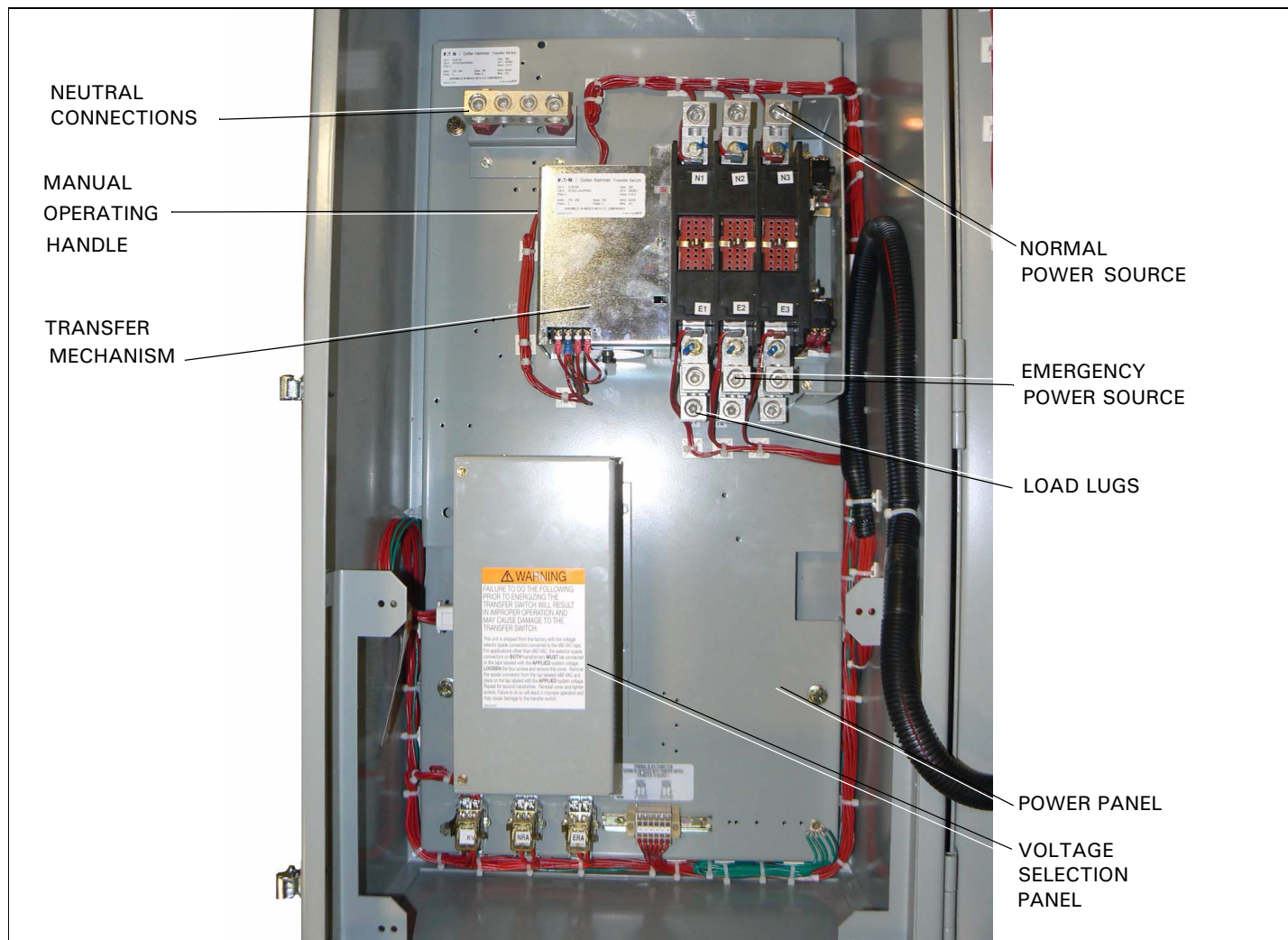

Figure 21. 100A, 3-Pole, ATS Interior Components.

Step 3: Turn the generator OFF at the generator control panel. This will prevent unexpected activation of the generator.

Step 4: Connect the Engine Generator Start wires to terminals 13 and 14 on the J-5 connector on the ATC-300 Controller (Figure 22). This contact is CLOSED whenever

the engine generator is needed, and should be connected to a generator controller. **NEVER** connect directly to a starter solenoid or ignition system. See the Genset manufacturer instruction leaflet for recommended wire sizes and location procedures.

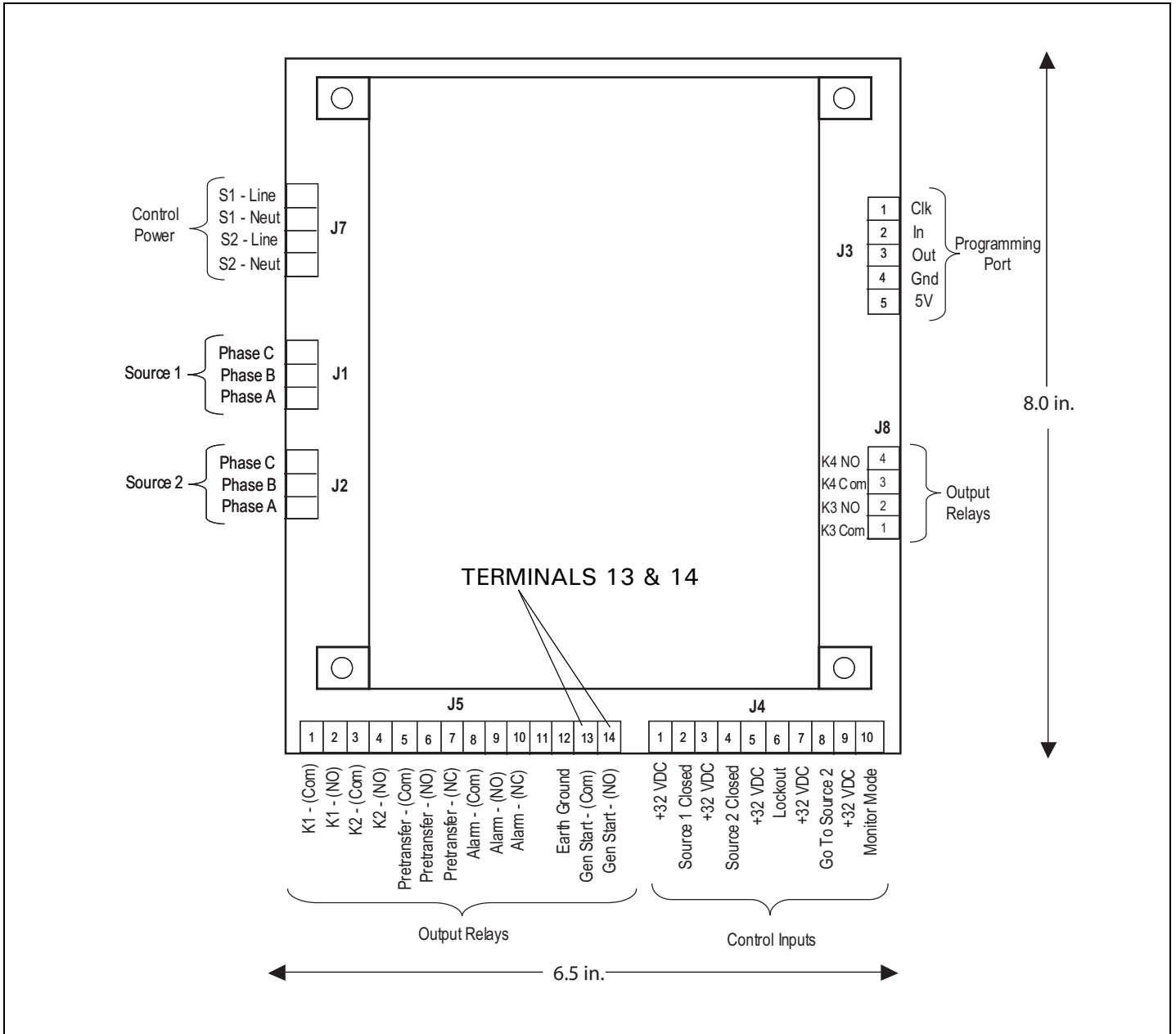

Figure 22. Engine Generator Control Connection.

Step 5: Apply Utility (Source 1) power. If the switch is properly applied for the system voltage ordered, the display should work and the Source 1 Available white LED should light (Figure 23). Using a voltmeter, check for proper system voltage on Source 1 and load terminals. Check all phases on a 3-phase switch. Voltage measurements should be taken phase to phase and phase to neutral.

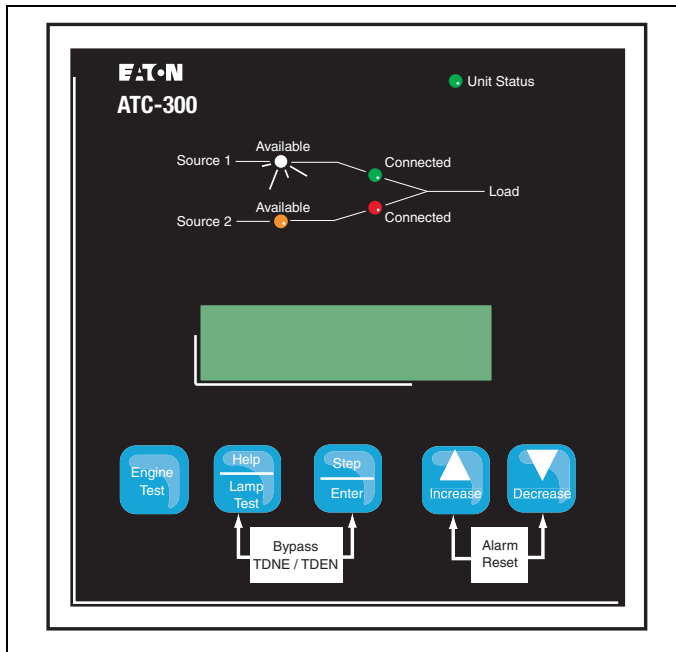

Figure 23. ATC-300 Logic (Utility Supplying Load).

Step 6: To view the setpoints, press the <Step/Enter> pushbutton and enter the Password.

Note: The factory default Password is 0300. Once all installation and testing is complete, the Password should be changed by authorized personnel to a unique Password for the equipment.

After entering the password, press the <Step/Enter> pushbutton until the VIEW SETPOINTS menu appears. Select YES. Press the <Step/Enter> pushbutton to scroll through the setpoints (Figures 24 through 26 and Table 6).

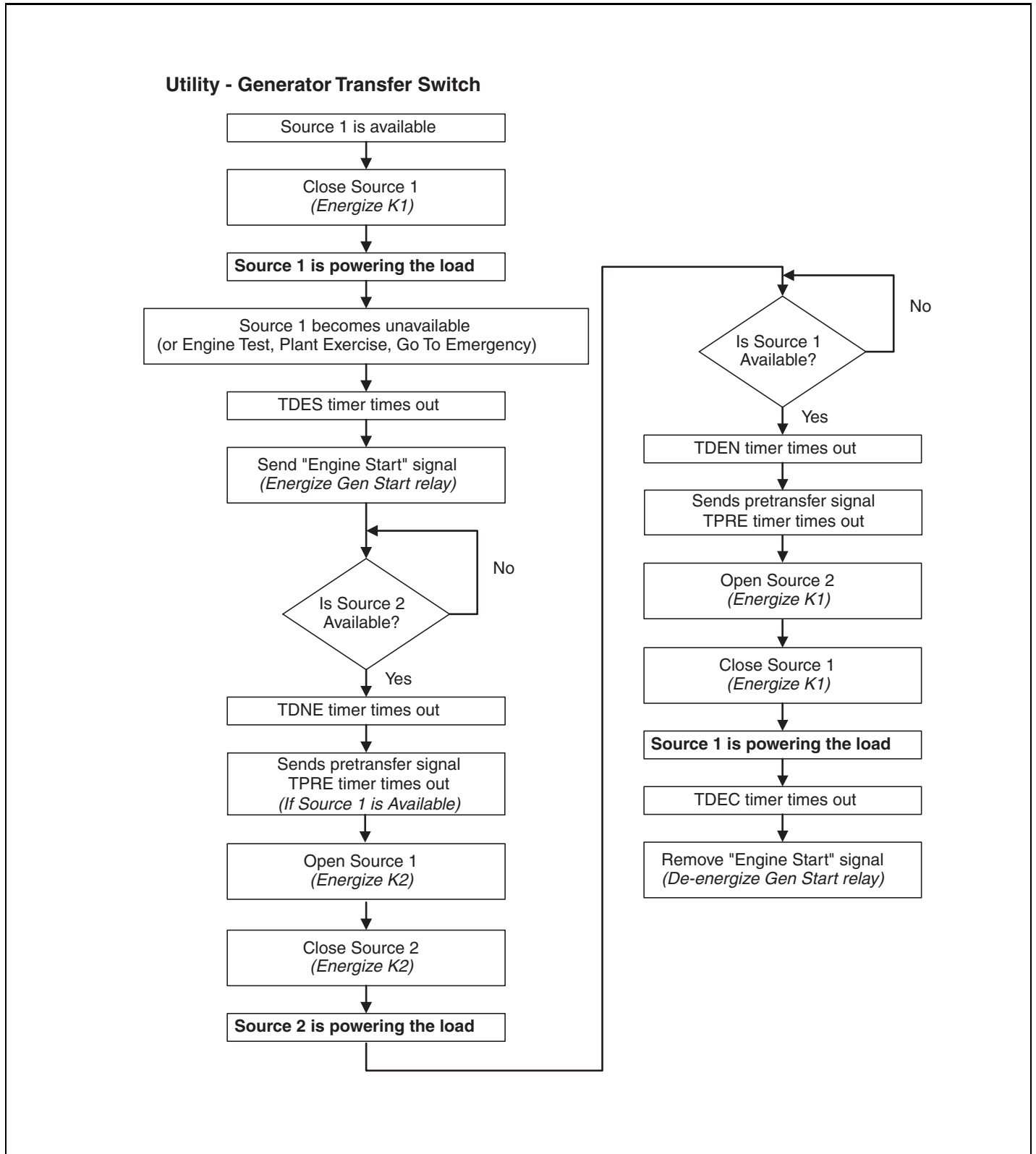

Figure 24. Utility - Generator Transfer Switch.

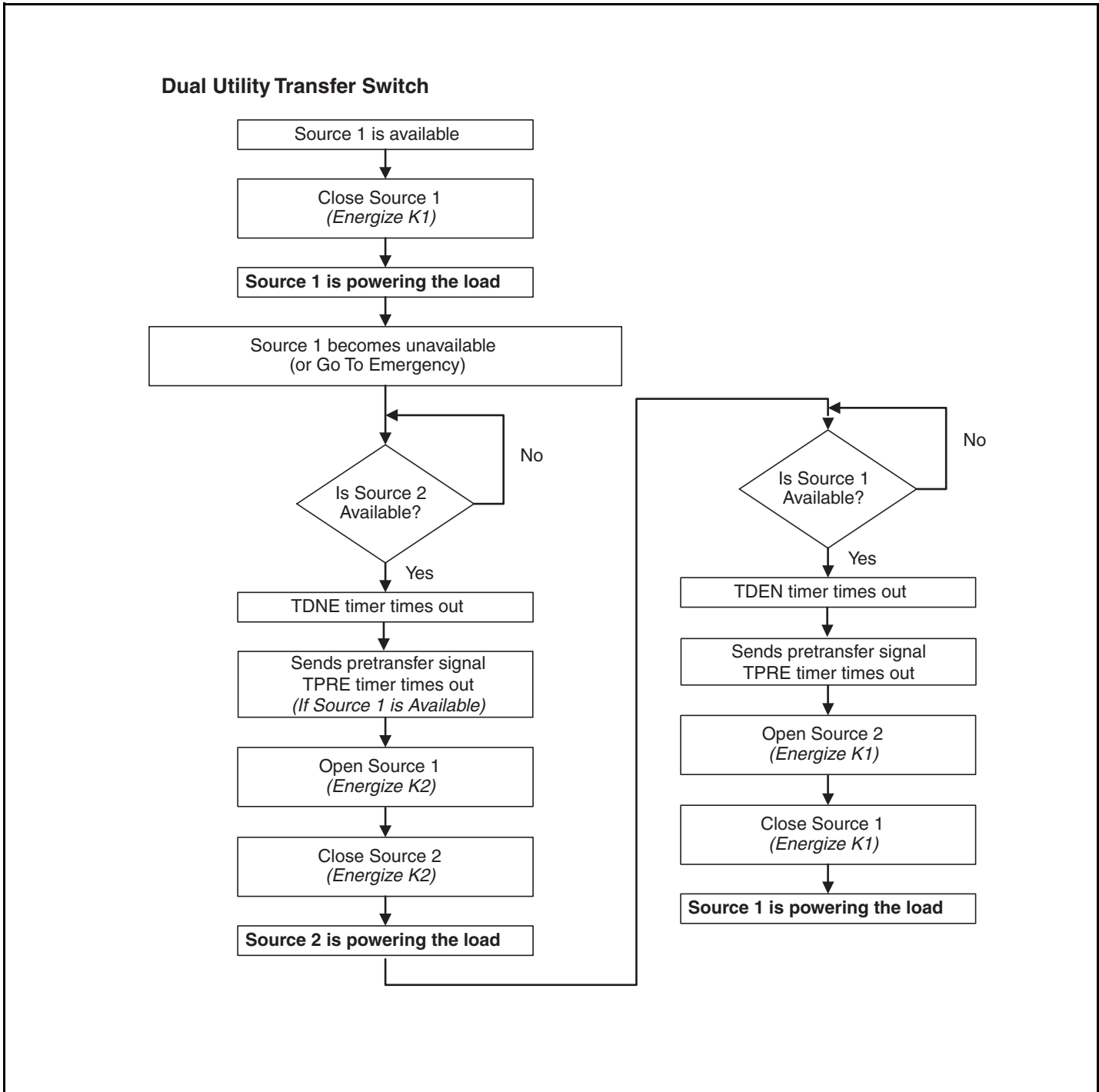

Figure 25. Dual Utility Transfer Switch.

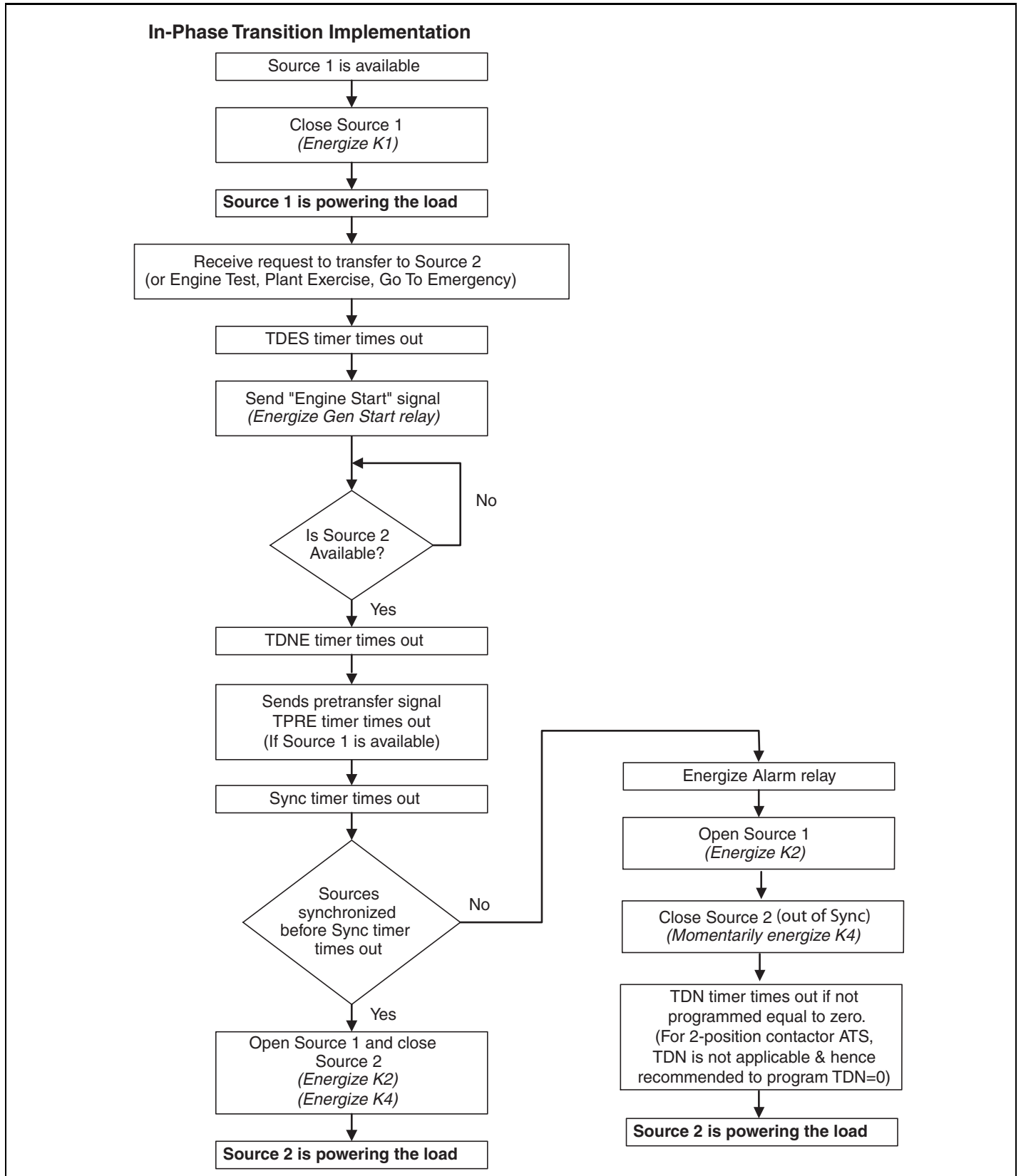

Figure 26. In-Phase Transition Implementation.

Table 6. Setpoint Possibilities

SETPOINT	SETPOINT UNITS	DESCRIPTION	RANGE	FACTORY DEFAULT
New Password	Four Digits	Set New Password	0000 to 9999	0300
TDES	Minutes: Seconds	Time Delay Engine Start	0 to 120 seconds	0:03
TDNE	Minutes: Seconds	Time Delay Normal to Emergency	0 to 1800 seconds	0:00
TDEN	Minutes: Seconds	Time Delay Emergency to Normal	0 to 1800 seconds	5:00
TDEC	Minutes: Seconds	Time Delay Engine Cool-off	0 to 1800 seconds	5:00
NOM FREQ	Hertz	Nominal Frequency	50 or 60 Hz	As ordered
NOM VOLTS	Volts	Nominal Voltage	120 to 600 volts	As ordered
S1 UV DROP	Volts	Source 1 Undervoltage Dropout Range: Contactor Style ATS (2-position)	78 to 97% of Nominal System Voltage	85%
S2 UV DROP	Volts	Source 2 Undervoltage Dropout Range: Contactor Style ATS (2-position)	78 to 97% of Nominal System Voltage	85%
S1 UV PICK	Volts	Source 1 Undervoltage Pickup Range: Contactor Style ATS (2-position)	(Dropout + 2%) to 99% of Nominal System Voltage	90%
S2 UV PICK	Volts	Source 2 Undervoltage Pickup Range: Contactor Style ATS (2-position)	(Dropout + 2%) to 99% of Nominal System Voltage	90%
S1 OV DROP	Volts	Source 1 Overvoltage Dropout Range: Contactor Style ATS (2-position)	105 to 110% of Nominal System Voltage	110%
S2 OV DROP	Volts	Source 2 Overvoltage Dropout Range: Contactor Style ATS (2-position)	105 to 110% of Nominal System Voltage	110%
S1 OV PICK	Volts	Source 1 Overvoltage Pickup Range: Contactor Style ATS (2-position)	103% to (Dropout -2%) of Nominal System Voltage	105%
S2 OV PICK	Volts	Source 2 Overvoltage Pickup Range: Contactor Style ATS (2-position)	103% to (Dropout -2%) of Nominal System Voltage	105%
S1 UF DROP	Hertz	Source 1 Underfrequency Dropout Range: Contactor Style ATS (2-position)	90 to 97% of Nominal System Frequency	90%
S2 UF DROP	Hertz	Source 2 Underfrequency Dropout Range: Contactor Style ATS (2-position)	90 to 97% of Nominal System Frequency	90%
S1 UF PICK	Hertz	Source 1 Underfrequency Pickup Range: Contactor Style ATS (2-position)	(Dropout + 1 Hz) to 99% of Nominal System Frequency	95%
S2 UF PICK	Hertz	Source 2 Underfrequency Pickup Range: Contactor Style ATS (2-position)	(Dropout + 1 Hz) to 99% of Nominal System Frequency	95%
S1 OF DROP	Hertz	Source 1 Overfrequency Dropout Range: Contactor Style ATS (2-position)	103 to 105% of Nominal System Frequency	105%
S2 OF DROP	Hertz	Source 2 Overfrequency Dropout Range: Contactor Style ATS (2-position)	103 to 105% of Nominal System Frequency	105%
S1 OF PICK	Hertz	Source 1 Overfrequency Pickup Range: Contactor Style ATS (2-position)	101% to (Dropout -1 Hz) of Nominal System Frequency	102%
S2 OF PICK	Hertz	Source 2 Overfrequency Pickup Range: Contactor Style ATS (2-position)	101% to (Dropout -1 Hz) of Nominal System Frequency	102%
PLANT EXER	Days	Plant Exerciser Programming	OFF, DAILY, 7-DAY, 14-DAY or 28 DAY	OFF
PE LOAD XFR		Plant Exerciser Load Transfer	0 or 1 (1 = yes)	0
PE DAY	Days	Plant Exerciser Day of the Week	1 SUN, 2 MON, 3 TUE, 4 WED, 5 THU, 6 FRI or 7 SAT	
PE HOUR	Hours	Plant Exerciser Hour	0 to 23	0
PE MINUTE	Minutes	Plant Exerciser Minute	0 to 59	0
TEST MODE		Test Mode	0, 1 or 2 (0 = No Load Engine Test, 1 = Load Engine Test, 2 = Disabled)	0
TER	Hours: Minutes	Engine run test time	0 min to 600 min	5:00
TPRE	Minutes: Seconds	Pretransfer delay timer	0 sec to 120 sec	0:00
PHASES		Three phase or single phase	1 or 3	AS ORDERED
VOLT UNBAL	Volts	Voltage Unbalanced	0 or 1 (1 = Enabled)	1
UNBAL DROP %	Percent	Percent for Unbalanced Voltage Dropout	5 to 20% of Phase to Phase Voltage Unbalance	20%
UNBAL PICK %	Percent	Percent for Unbalanced Voltage Pickup	Dropout minus (UNBAL DROP % -2) to 3%	10%
UNBAL DELAY	Seconds	Unbalanced Delay Timer	10 to 30	0:20
TDEF	Seconds	Time Delay Emergency Fail Timer	0 sec to 6 sec	6
IN-PHASE	Hertz	In-phase Transition	0 or 1 (1 = Enabled)	1
IP FREQ DIFF	Hertz	In-phase Transition Frequency Difference	0.0 Hz to 3.0 Hz	1

Table 6. Setpoint Possibilities (cont')

SETPOINT	SETPOINT UNITS	DESCRIPTION	RANGE	FACTORY DEFAULT
SYNC TIME	Minutes	In-phase Transition Synchronization Timer	1 min to 60 min	5
PHASE REV		Phase Reversal	OFF, ABC, or CBA	OFF
DST ADJUST		Day Light Savings	0 or 1 (1 = Enabled)	1
LANGUAGE		Selected Language	English, French, or Spanish	English
CHANGE TIME/DATE?		Set Time and Date		
	Hours	Set Hour	0 to 23	Eastern Standard Time
	MINUTES	Set Minute	0 to 59	Eastern Standard Time
	WEEKDAY	Set Weekday	SUN, MON, TUE, WED, THU, FRI or SAT	Eastern Standard Time
	MONTH	Set Month	JAN or 01	Eastern Standard Time
	DAY	Set Day	1 to 31	Eastern Standard Time
	YEAR	Set Year	Current Year	Eastern Standard Time
RESET SYSTEM COUNTERS?			Yes or No	No
RESET ALL?		Resets all System Counters	Yes or No	No
RESET ENGINE RUN?	Hours	Resets ENGINE RUN Counter	0 to 9999	XXXX
RESET S1 CONN	Hours	Resets S1 CONN Counter	0 to 9999	XXXX
RESET S2 CONN	Hours	Resets S2 CONN Counter	0 to 9999	XXXX
RESET S1 AVAIL	Hours	Resets S1 AVAIL Counter	0 to 9999	XXXX
RESET S2 AVAIL	Hours	Resets S2 AVAIL Counter	0 to 9999	XXXX
RESET LOAD ENERG	Hours	Resets LOAD ENERG Counter	0 to 9999	XXXX
RESET TRANSFERS	Hours	Resets TRANSFERS Counter	0 to 9999	XXXX
SAVE SETPOINTS?		Save Changed Setpoints	Yes or No	Yes

See tables in the appendix for Voltage and Frequency Pickup and Dropout settings.

Step 7: To change or add a setpoint, select **Yes** when the "Change Setpoints" message appears on the screen. Use the **<Step/Enter>** pushbutton to step through the setpoints.

Use the **<Increase>** and **<Decrease>** pushbuttons to change the setpoint.

When finished scrolling through and changing the desired setpoints, answer **Yes** when the "Save Setpoints?" question appears on the screen. The display will return to the default screen.

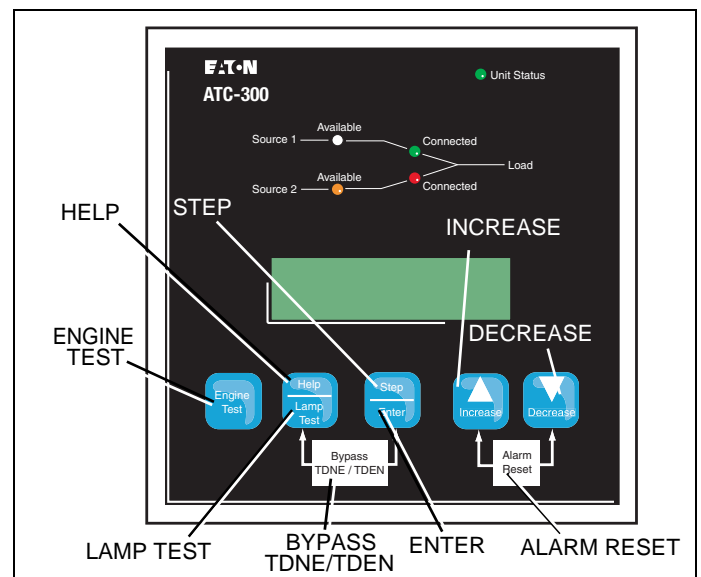

Figure 27. ATC-300 Pushbuttons.

ATC-300 Contactor Based Transfer Switch

WARNING

THE GENERATOR SHOULD BE MANUALLY STARTED AND THE OUTPUT CHECKED AND VERIFIED BEFORE PROCEEDING TO STEP 8. IF IMPROPER VOLTAGE/FREQUENCY IS APPLIED TO THE LOAD, THE ATS MAY BE DAMAGED.

Step 8: Manually start the engine generator at the generator controller. Check that the generator is running and the *Source 2 Available* amber LED is lit. Press the **<Step/Enter>** pushbutton, step through the phase voltages, frequency, and message display. If the source message indicates that the source is Good, shut down the generator and place the Genset controller in the Auto-operating position. If the message indicates a problem with the source, the setpoints should be reviewed and the generator checked for proper voltage and frequency output.

Step 9: Initiate a Load Test from the front panel of the ATC-300 (Figure 28). This may be done by setting the engine test setpoint to:

- 1 Load Test

then saving the setpoints. Once the engine test setpoint has been changed and saved, press the **<Engine Test>** pushbutton twice. The generator should start, the ATS should transfer and run on the generator for the set test interval, then proceed to a TDEN countdown and return to Source 1. While the ATS is connected to Source 2, use a voltmeter to check for correct system voltage on the load terminals of the ATS. Check all phases on a 3-phase system. Voltage measurements should be taken phase to phase and phase to neutral. A load test will cause a momentary power outage during transfer.

Step 10: ATC3 Controlled ATS Power Failure Test - Initiate a Load Test by simulating an actual power failure.

1. This should be done by opening the upstream breaker or fused disconnect switch.
2. The generator should start and the ATS should transfer to Source 2.
3. After transfer, close the upstream breaker, or close the Source 1 Control Circuit Fused Disconnect. The TDEN timer should begin counting, and, when complete, the ATS should transfer to Source 1. The TDEC should time out and shut the Source 2 power unit down.

NOTICE

WHILE PERFORMING TESTING, IF AN UNDESIRED OR UNDOCUMENTED RESULT OCCURS, FIRST CONTACT THE LOCAL GENSET DEALER. IF THE RESULT IS NOT CORRECTED, CONTACT THE EATON POWER QUALITY TECHNICAL SUPPORT CENTER AT 1-800-354-2070.

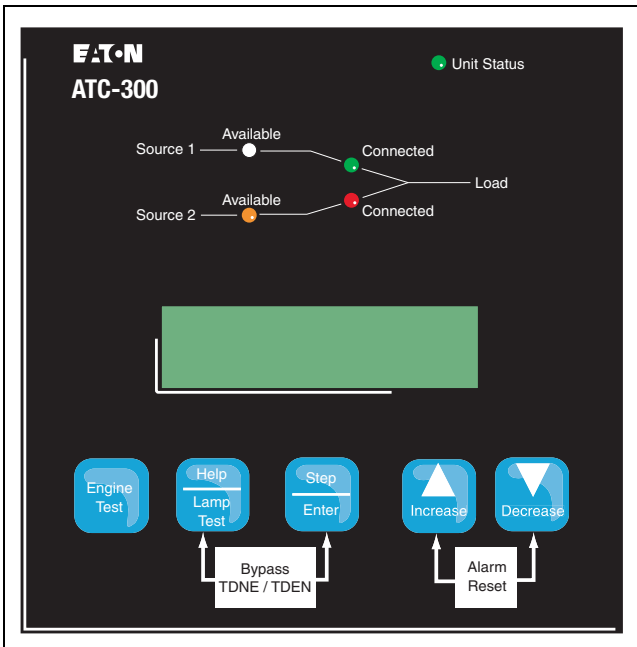

Figure 28. ATC-300 Logic.

Appendix A: Pickup / Dropout Tables

UNDervOLTAGE PICKUP / DROPOUT TABLE

PERCENTAGE	VOLTAGE							
	120	208	220	240	380	415	480	600
97	116	202	213	233	369	403	466	582
96	115	200	211	230	365	398	461	576
95	114	198	209	228	361	394	456	570
94	113	196	207	226	357	390	451	564
93	112	193	205	223	353	386	446	558
92	110	191	202	221	350	382	442	552
91	109	189	200	218	346	378	437	546
90	108	187	198	216	342	374	432	540
89	107	185	196	214	338	369	427	534
88	106	183	194	211	334	365	422	528
87	104	181	191	209	331	361	418	522
86	103	179	189	206	327	357	413	516
85	102	177	187	204	323	353	408	510
84	101	175	185	202	319	349	403	504
83	100	173	183	199	315	344	398	498
82	98	171	180	197	312	340	394	492
81	97	168	178	194	308	336	389	486
80	96	166	176	192	304	332	384	480
79	95	164	174	190	300	328	379	474
78	94	162	172	187	296	324	374	468
77	92	160	169	185	293	320	370	462
76	91	158	167	182	289	315	365	456
75	90	156	165	180	285	311	360	450
74	89	154	163	178	281	307	355	444
73	88	152	161	175	277	303	350	438
72	86	150	158	173	274	299	346	432
71	85	148	156	170	270	295	341	426
70	84	146	154	168	266	291	336	420
69	83	144	152	166	262	286	331	414
68	82	141	150	163	258	282	326	408
67	80	139	147	161	255	278	322	402
66	79	137	145	158	251	274	317	396
65	78	135	143	156	247	270	312	390
64	77	133	141	154	243	266	307	384
63	76	131	139	151	239	261	302	378
62	74	129	136	149	236	257	298	372
61	73	127	134	146	232	253	293	366
60	72	125	132	144	228	249	288	360
59	71	123	130	142	224	245	283	354
58	70	121	128	139	220	241	278	348
57	68	119	125	137	217	237	274	342
56	67	116	123	134	213	232	269	336
55	66	114	121	132	209	228	264	330
54	65	112	119	130	205	224	259	324
53	64	110	117	127	201	220	254	318
52	62	108	114	125	198	216	250	312
51	61	106	112	122	194	212	245	306
50	60	104	110	120	190	208	240	300

ATC-300 2-Position Contactor Based Transfer Switch

OVERVOLTAGE PICKUP / DROPOUT TABLE

PERCENTAGE	VOLTAGE								
	120	208	220	240	380	415	480	600	
120	144	250	264	288	456	498	576	720	
119	143	248	262	286	452	494	571	714	
118	142	245	260	283	448	490	566	708	
117	140	243	257	281	445	486	562	702	
116	139	241	255	278	441	481	557	696	
115	138	239	253	276	437	477	552	690	
114	137	237	251	274	433	473	547	684	
113	136	235	249	271	429	469	542	678	
112	134	233	246	269	426	465	538	672	
111	133	231	244	266	422	461	533	666	
110	132	229	242	264	418	457	528	660	Dropout
109	131	227	240	262	414	452	523	654	
108	130	225	238	259	410	448	518	648	
107	128	223	235	257	407	444	514	642	
106	127	220	233	254	403	440	509	636	
105	126	218	231	252	399	436	504	630	Pickup

UNDERFREQUENCY PICKUP / DROPOUT TABLE

PERCENTAGE	FREQUENCY		
	50	60	
97	49	58	
96	48	58	
95	48	57	Pickup
94	47	56	
93	47	56	
92	46	55	
91	46	55	
90	45	54	Dropout

OVERFREQUENCY PICKUP / DROPOUT TABLE

PERCENTAGE	FREQUENCY		
	50	60	
110	55	66	
109	55	65	
108	54	65	
107	54	64	
106	53	64	
105	53	63	Dropout
104	52	62	
103	52	62	
102	51	61	Pickup



ATC-300 2-Position Contactor Based Transfer Switch

Notes:



**ATC-300 2-Position Contactor
Based Transfer Switch**

Notes:



ATC-300 2-Position Contactor Based Transfer Switch

Notes:

This instruction booklet is published solely for information purposes and should not be considered all-inclusive. If further information is required, you should consult Eaton.

Sale of the product(s) shown in this literature is subject to terms and conditions outlined in appropriate Eaton selling policies or other contractual agreements between the parties. This literature is not intended to and does not enlarge or add to any such contract. The sole source governing the rights and remedies of any purchaser of this equipment is the contract between the purchaser and Eaton.

NO WARRANTIES, EXPRESSED OR IMPLIED, INCLUDING WARRANTIES OF FITNESS FOR A PARTICULAR PURPOSE OR MERCHANTABILITY, OR WARRANTIES ARISING FROM COURSE OF DEALING OR USAGE OF TRADE, ARE MADE REGARDING THE INFORMATION, RECOMMENDATIONS AND DESCRIPTIONS CONTAINED HEREIN. In no event will Eaton be responsible to the purchaser or user in contract, in tort (including negligence), strict liability or otherwise for any special, indirect, incidental or consequential damage or loss whatsoever, including but not limited to damage or loss of use of equipment, plant or power system, cost of capital, loss of power, additional expenses in the use of existing power facilities, or claims against the purchaser or user by its customers resulting from the use of the information, recommendations and description contained herein.

CSA is a registered trademark of the Canadian Standards Association. National Electrical Code and NEC are registered trademarks of the National Fire Protection Association, Quincy, Mass. NEMA is the registered trademark and service mark of the National Electrical Manufacturers Association. Uniform Building Code (UBC) is a trademark of the International Conference of Building Officials (ICBO). UL is a federally registered trademark of the Underwriters Laboratories Inc.

Eaton Corporation
Electrical Group
1000 Cherrington Parkway
Moon Township, PA 15108
United States
877-ETN-CARE (877-386-2273)
Eaton.com