



Powering Business Worldwide

## O & M Manual for the EATON ATC-300 + Automatic Transfer Switch Controller

Instruction Booklet

<i>Description</i>	<i>Page</i>
Introduction . . . . .	2
Hardware Description . . . . .	7
Status Monitoring and Setpoints . . . . .	11
Typical Function of the ATC-300 + Controller. . . . .	13
Operation . . . . .	15
Programming . . . . .	20
Troubleshooting and Maintenance . . . . .	24
Appendix A: Display Messages for Status and Timers . . . . .	26
Appendix B: Operational Flowcharts . . . . .	27
Appendix C: Display Menu Tree . . . . .	30
Appendix D: Pickup / Dropout Tables . . . . .	36

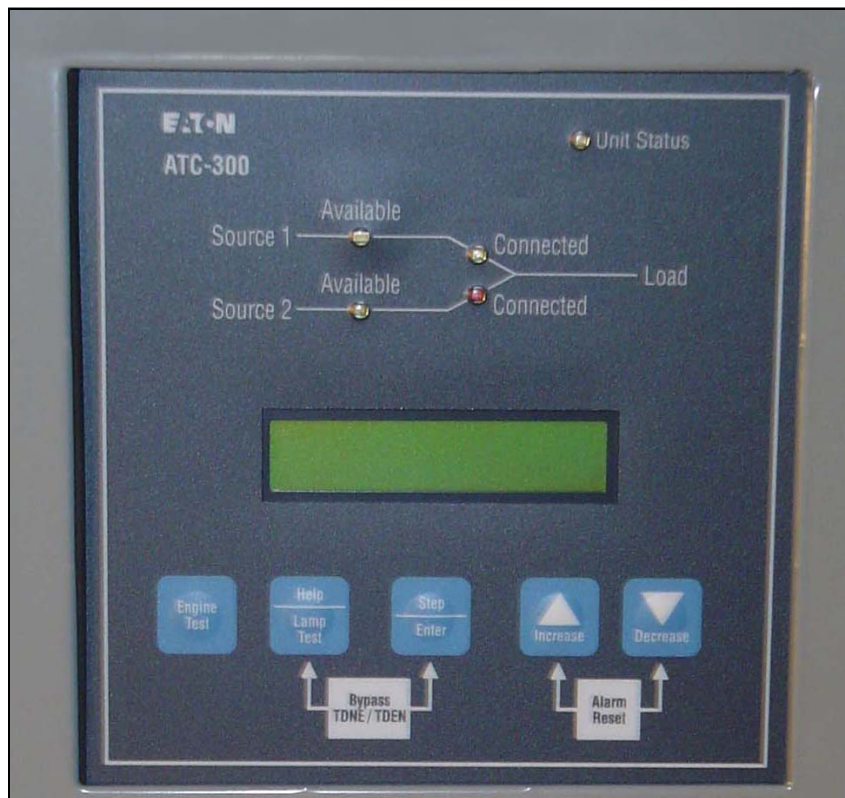

**CAUTION**

THE ATC-300+ CONTROLLER IS FACTORY PROGRAMMED FOR A SPECIFIC AUTOMATIC TRANSFER SWITCH. DO NOT ATTEMPT TO INTERCHANGE ATC-300+ CONTROL DEVICES WITHOUT CONSULTING EATON ELECTRICAL.

All possible contingencies that may arise during installation, operation, or maintenance, and all details and variations of this equipment do no purport to be covered by these instructions. If further information is desired by the purchaser regarding a particular installation, operation, or maintenance of particular equipment, please contact an authorized EATON Sales Representative or the installing contractor.

**Section 1: Introduction****1.1 Preliminary Comments and Safety Precautions**

This technical document is intended to cover most aspects associated with the installation, application, operation, and maintenance of the Automatic Transfer Controller (ATC)-300 Controller. It is provided as a guide for authorized and qualified personnel only in the selection and application of the ATC-300+ Controller. Please refer to the specific WARNING and CAUTION in Section 1.1.2 before proceeding. If further information is required by the purchaser regarding a particular installation, application, or maintenance activity, please contact an authorized EATON sales representative or the installing contractor.

**1.1.1 Warranty and Liability Information**

No warranties, expressed or implied, including warranties of fitness for a particular purpose of merchantability, or warranties arising from course of dealing or usage of trade, are made regarding the information, recommendations and descriptions contained herein. In no event will EATON be responsible to the purchaser or user in contract, in tort (including negligence), strict liability or otherwise for any special, indirect, incidental or consequential damage or loss whatsoever, including but not limited to damage or loss of use of equipment, plant or power system, cost of capital, loss of power, additional expenses in the use of existing power facilities, or claims against the purchaser or user by its customers resulting from the use of the information and descriptions contained herein.

**1.1.2 Safety Precautions**

All safety codes, safety standards, and/or regulations must be strictly observed in the installation, operation, and maintenance of this device.

**WARNING**

THE WARNINGS AND CAUTIONS INCLUDED AS PART OF THE PROCEDURAL STEPS IN THIS DOCUMENT ARE FOR PERSONNEL SAFETY AND PROTECTION OF EQUIPMENT FROM DAMAGE. AN EXAMPLE OF A TYPICAL WARNING LABEL HEADING IS SHOWN ABOVE TO FAMILIARIZE PERSONNEL WITH THE STYLE OF PRESENTATION. THIS WILL HELP TO INSURE THAT PERSONNEL ARE ALERT TO WARNINGS, WHICH APPEAR THROUGHOUT THE DOCUMENT. IN ADDITION, WARNINGS AND CAUTIONS ARE ALL UPPER CASE AND BOLDFACE.

**CAUTION**

COMPLETELY READ AND UNDERSTAND THE MATERIAL PRESENTED IN THIS DOCUMENT BEFORE ATTEMPTING INSTALLATION, OPERATION, OR APPLICATION OF THE EQUIPMENT. IN ADDITION, ONLY QUALIFIED PERSONS SHOULD BE PERMITTED TO PERFORM ANY WORK ASSOCIATED WITH THIS EQUIPMENT. ANY WIRING INSTRUCTIONS PRESENTED IN THIS DOCUMENT MUST BE FOLLOWED PRECISELY. FAILURE TO DO SO COULD CAUSE PERMANENT EQUIPMENT DAMAGE.

**1.2 Background**

Transfer switches are used to protect critical electrical loads against loss of power. The load's Source 1 power source is backed up by a Source 2 power source. A transfer switch is connected to both the Source 1 and Source 2 power sources and supplies the load with power from one of the two sources. In the event that power is lost from Source 1, the transfer switch transfers the load to the Source 2 power source. This transfer can be automatic or manual, depending upon the type of transfer switch equipment being used. Once Source 1 power is restored, the load is automatically or manually transferred back to the Source 1 power source, again depending upon the type of transfer equipment being used.

In automatic transfer switch (ATS) equipment, the switch's intelligence system initiates the transfer when the Source 1 power falls below or rises above a preset voltage or frequency. If the Source 2 power source is a standby generator, the ATS initiates generator start up then transfers to the Source 2 power source when sufficient generator voltage is available. When Source 1 power is restored, the ATS automatically transfers back to the Source 1 power source and initiates generator engine shutdown.

An ATS consist of three basic elements:

1. Main contacts to connect and disconnect the load to and from the power sources.
2. A mechanism to transfer the main contacts from source to source.
3. Intelligence/supervisory circuits to constantly monitor the condition of the power sources and thus provide the intelligence necessary for the switch and related circuit operation.

This manual deals with the third basic element of the ATS, the required intelligence/supervisory circuits. Earlier ATSs were controlled by relay logic type or a solid-state, single board controllers. In either case, the control panel consisted of a number of individually mounted and wired devices offering a limited amount of system flexibility, especially in the case of the relay logic design. The ATC-300+ Controller advances the application of intelligence, supervisory, and programming capabilities for ATS equipment.

**1.3 Product Overview**

The ATC-300+ Controller is a comprehensive, multi-function, microprocessor based ATS controller. It is a compact, self-contained, panel mounted device designed to replace traditional relay and solid-state logic panels.

## ATC-300+ Automatic Transfer Switch Controller

Designed to meet the needs of markets worldwide, the ATC-300+ Controller:

- Is a UL Recognized Component
- Complies with UL 1008/ CSA 22.2-178
- Meets the Intent of UL 991
- Meets IEC 1000-4-2, 1000-4-3, 1000-4-4, 1000-4-5, 1000-4-6, and 1000-4-11
- Meets CISPR 11, Class A
- Complies with FCC Part 15, Class A
- Meets European Standards Conformance (CE mark)

The ATC-300+ Controller provides an unmatched degree of programmed flexibility to address the needs of any system. It operates from all system voltages between 120 and 600 Vac, single-phase and 3-phase, at 50 or 60 Hz. In addition, a period of no control power operation is provided. The ATC-300+ Controller monitors the condition of the 3-phase line-to-line voltage and frequency of both the Source 1 and Source 2 power sources. It can also be programmed for single-phase operation. The ATC-300+ Controller provides the necessary intelligence to insure that the switch operates properly through a series of programmed sensing and timing functions.

A standard ATC-300+ Controller will:

- Monitor Source 1 and Source 2 power source voltages and frequencies;
- Provide undervoltage monitoring of the Source 1 and Source 2 power sources;
- Permit customer programming;
- Display real-time and historical information;
- Permit system testing;
- Store customer/factory established parameters in nonvolatile memory; and
- Provide faceplate source status indications.

### 1.4 Glossary

With respect to their use within this document and as they relate to ATS and controller operation, the following terminology is defined.

#### Available

A source is defined as "available" when it is within its undervoltage/overvoltage/ underfrequency/overfrequency (if applicable) setpoint ranges for the nominal voltage and frequency setting.

#### Connected

Connected is defined as when the input is shorted by an external contact or connection.

#### Failed or Fails

A source is defined as "failed" when it is outside of the applicable voltage and frequency setpoint ranges for the nominal voltage and frequency setting for a time exceeding 0.5 seconds after the time delay emergency fail (TDEF) time delays expires.

#### Failsafe

Failsafe is a feature that prevents disconnection from the only available power source and also forces a transfer or re-transfer operation to the only available power source.

#### Re-Transfer

Re-transfer is defined as a change of the load connection from the Source 2 to the Source 1.

#### Source 1

Source 1 is the primary source (normal source, normal power source, or normal).

#### Source 2

Source 2 is the secondary source (emergency source, emergency power source, emergency, standby, or backup source).

#### Source 1: Failed or Fails

Source 1 is defined as "failed" when it is outside of its undervoltage/overvoltage/ underfrequency/overfrequency (if applicable) setpoint ranges for the nominal voltage and frequency setting.

#### Source 2: Failed or Fails

Source 2 is defined as "failed" when it is outside of its undervoltage/overvoltage/ underfrequency/overfrequency (if applicable) setpoint ranges for the nominal voltage and frequency setting for a time exceeding 0.5 seconds after the TDEF time delay expires.

#### Transfer

Transfer is defined as a change of the load connection from the Source 1 to the Source 2 power source, except when specifically used as "Transfer to Neutral".

#### Transfer to Neutral

Transfer to neutral is defined as when the load circuits are disconnect from both the Source 1 and Source 2 power sources.

#### Unconnected

Unconnected is defined as when the input is not shorted by an external contact or connection.

#### $V_{IN, RMS}$

Refers to the operating input voltage (Vac, RMS).

## 1.5 Functions/Features/Options

The primary function of ATC-300+ Controller is to accurately monitor power sources and provide the necessary intelligence to operate an ATS in an appropriate and timely manner. In addition, the ATC-300+ Controller provides programming through the device's faceplate or communication option.

### 1.5.1 Operational Simplicity

From installation to programming to usage, the ATC-300+ Controller was designed with operational simplicity in mind. Only one style needs to be considered, regardless of input/output requirements or system voltages and frequencies. The ATC-300+ Controller provides the functionality of numerous other devices combined in one package that mounts in 6.5 by 8.5 inches of panel space.

The user-friendly front panel interface simplifies routine operation, programming, data presentation, and setting adjustments. An LCD-based display provides the flexibility of a back-lit display for enhanced visibility. The operation of the front panel membrane pushbuttons move the ATC-300+ Controller display from function to function or step to step within a function.

**1.5.2 Standard and Optional Features**

A variety of programmable features are available with the ATC 300 Controller to meet a wide variety of application requirements. Individual features or feature combinations provide the intelligence required to tailor ATSS to individual needs.

The features are factory activated, depending upon customer requirements. The specific variable setpoints associated with standard and factory activated features are stored in nonvolatile memory. Activated feature setpoints are available for customer adjustment. Any feature not selected and factory activated cannot be viewed or adjusted.

**1.5.2.1 Standard Features**

The following is a list of the standard features of the ATC-300+ Controller.

**1. Time Delay Normal to Emergency (TDNE)**

This feature provides a time delay when transferring from the Source 1 to the Source 2 power source. Timing begins when Source 2 becomes available. It permits controlled transfer of the load circuit to Source 2.

Adjustable 0 - 1800 Seconds

**2. Time Delay on Engine Starting (TDES)**

This feature provides a time delay of the signal to initiate the engine/generator start cycle in order to override momentary power outages or voltage fluctuations of Source 1.

Adjustable 0 - 120 Seconds

**3. Time Delay Emergency to Normal (TDEN)**

This feature provides a time delay of the re-transfer operation to permit stabilization of Source 1. Timing begins when Source 1 becomes available. If Source 2 fails during timing, then re-transfer is immediate, overriding the time delay.

Adjustable 0 - 1800 Seconds

**4. Time Delay for Engine Cool-down (TDEC)**

This feature provides a time delay of the signal to initiate the engine/generator stop cycle after the re-transfer operation. This allows the engine/generator to cool down by running unloaded. Timing begins on completion of the re-transfer cycle.

Adjustable 0 - 1800 Seconds

**5. Source 2 Monitoring and Protection**

This feature provides monitoring and protection based on the Source 2 voltage and/or frequency setpoints. All feature 5 functions are "failsafe" operations.

**5H. Phase Reversal**

For a 3-phase wye source, this feature monitors the phase sequence of the sources. If a source does not have the same ABC or CBA sequence as the setpoint value, that source will be considered "Unavailable".

For a 3-phase delta source, this feature should be turned off via the PHASE REV setpoint.

**5J. 3-Phase Undervoltage and Underfrequency Protection**

Adjustable Undervoltage:  
 Dropout (Breaker Style): 50 - 97% of nominal  
 Dropout (Contactor Style): 78 - 97% of nominal  
 Pickup: (Dropout + 2%) - 99% of nominal

Adjustable Underfrequency:  
 Dropout (Breaker Style): 90 - 97% of nominal  
 Dropout (Contactor Style): 90 - 97% of nominal  
 Pickup: (Dropout + 1Hz) - 99% of nominal

**5K. 3-Phase Overvoltage/Overfrequency**

Adjustable Overvoltage:  
 Dropout (Breaker Style): 105 - 120% of nominal  
 Dropout (Contactor Style): 105 - 110% of nominal  
 Pickup: 103% - (Dropout - 2%) of nominal

Adjustable Overfrequency:  
 Dropout (Breaker Style): 103 - 110% of nominal  
 Dropout (Contactor Style): 103 - 105% of nominal  
 Pickup: 101% - (Dropout - 1Hz) of nominal

**5L. Source 2 3-Phase Source 2 Voltage Unbalance**

For a 3-phase wye source, this feature monitors phase voltage ratios. Voltage unbalance (%) is calculated as the difference between the maximum and minimum phase voltage, divided by the minimum phase voltage. User-selectable setpoints are available for dropout and pickup unbalance settings (minimum 2% differential). Dropout is adjustable from 5 to 20%. Pickup is adjustable from 3 to (Dropout - 2%). A setpoint for user-selectable time delay from 10 to 30 seconds is provided. The factory default setpoints are: 5% dropout, 3% pickup, and 30 seconds time delay. A user-selectable setpoint for enable and disable is also provided.

When an unbalance condition is detected on Source 2, the Unbalance Timer (TD UNBAL) starts timing. After TD UNBAL times out, Source 2 is declared "failed".

For a 3-phase delta source, this feature should be turned off via the VOLT UNBAL setpoint.

## ATC-300+ Automatic Transfer Switch Controller

### 6. Test Operators

Eaton ATCs are provided with a Test Pushbutton that simulates a loss of the Source 1 power source as standard (Feature 6B). All programmed time delays (TDNE, TDEN, etc.) will be performed as part of the Test. Engine run time of the Test is equal to the Plant Exerciser (Feature 23) programmed setpoint. All Tests are Failsafe protected.

### 6B. Test Pushbutton

Programmable setpoints include:

1. Load, No Load Testing, or Disabled and
2. Engine run time is equal to the Plant Exerciser (Feature 23) setting.

### 7. Time Delay Emergency Fail (TDEF)

This feature provides a time delay that prevents a connected emergency source from being declared "failed" in order to override momentary generator fluctuations. If the Source 2 power source remains in the failed state then, 0.5 seconds after the TDEF timer expires, the transfer switch will proceed with the programmed sequence for re-transfer. This time delay is only implemented when the Source 2 power source is a generator.

Adjustable 0 - 6 Seconds

### 8. Time Delay Bypass Pushbutton

This feature provides a way (by pushing the Help and Step pushbutton simultaneously) to bypass the TDNE (Feature 1) and/or TDEN (Feature 2) time delays. The Time Delay Bypass function, when activated by pushing the Help and Step pushbutton simultaneously, will reduce any or all of the programmed time delay to zero.

### 8C. Bypass TDEN

This feature provides a membrane pushbutton to bypass the TDEN time delay.

### 8D. Bypass TDNE

This feature provides a membrane pushbutton to bypass the TDNE time delay.

### 12. Power Source Annunciation

This feature provides LEDs to give switch position and power source availability indications.

#### Switch Position

Provides LEDs to indicate the switch position.

### 12C. Source 1 - Source Connected

This feature provides a green LED that, when lit, indicates the load is connected to Source 1.

### 12D. Source 2 - Source Connected

This feature provides a red LED that, when lit, indicates the load is connected to Source 2.

#### Power Source Availability

Provides LEDs to indicate if a power source is available. LEDs may be integral or separate from the controller.

### 12G. Source 1 - Available

This feature provides a white LED that, when lit, indicates Source 1 is available.

### 12H. Source 2 - Available

This feature provides an amber LED that, when lit, indicates Source 2 is available.

### 23. Plant Exerciser (PE)

This feature provides a means for automatic testing of the engine/generator set or standby power system. All programmed time delays will be performed during plant exerciser operations.

### 23K. Plant Exerciser Selectable – Disabled/1/7/14/28 Day Interval

This feature provides for automatic test operation of the generator. Available test cycles are daily, 7, 14, or 28 days with duration equal to the programmed engine test time.

Programmable setpoints allow for selection of three test cycles:

- Engine Start/Run Only (No Load);
- Exercise with Load Transfer; or Disabled
- This is a "Failsafe" operation.

### 26. Source 1 - Monitoring and Protection

This feature provides Source 1 monitoring and protection functions. If the Source 1 power supply fails, then the ATC-300+ will begin the sequence of operations necessary to transfer the load circuit to the Source 2 power source. All Feature 26 monitoring and protection functions are "failsafe" operations.

### 26D. Go to Source 2

This feature provides the capability for an external contact opening to initiate a load power transfer to the Source 2 power source. This includes starting the engine/generator, performing the programmed time delays, and the transfer operation. Re-transfer will occur when the external contact is closed or under a "failsafe" condition. A connection point on the controller for the connection of an external contact is included.

**26H. Phase Reversal Protection**

For a 3-phase wye source, this feature monitors the phase sequence of the sources. If a source does not have the same ABC or CBA sequence as the phase reversal setpoint, the source will be considered "Unavailable".

For a 3-phase delta source, this feature should be turned off via the PHASE REV setpoint.

**26J. 3-Phase Undervoltage and Underfrequency Protection**

Adjustable Undervoltage:

Dropout (Breaker Style): 50 - 97% of nominal

Dropout (Contactor Style): 78 - 97% of nominal

Pickup: (Dropout + 2%) - 99% of nominal

Adjustable Underfrequency:

Dropout (Breaker Style): 90 - 97% of nominal

Dropout (Contactor Style): 90 - 97% of nominal

Pickup: (Dropout + 1Hz) - 99% of nominal

**26K. 3-Phase Overvoltage/Overfrequency**

Adjustable Overvoltage:

Dropout (Breaker Style): 105 - 120% of nominal

Dropout (Contactor Style): 105 - 110% of nominal

Pickup: 103% - (Dropout - 2%) of nominal

Adjustable Overfrequency:

Dropout (Breaker Style): 103 - 110% of nominal

Dropout (Contactor Style): 103 - 105% of nominal

Pickup: 101% - (Dropout - 1Hz) of nominal

**26L. Source 1 3-Phase Voltage Unbalance**

For a 3-phase wye source, this feature monitors phase voltage ratios. Voltage unbalance (%) is calculated as the difference between the maximum and minimum phase voltage, divided by the minimum phase voltage. User-selectable setpoints are available for dropout and pickup unbalance settings (minimum 2% differential). Dropout is adjustable from 5 to 20%. Pickup is adjustable from 3 to (Dropout - 2%). A setpoint for user-selectable time delay from 10 to 30 seconds is provided. The factory default setpoints are: 5% dropout, 3% pickup, and 30 seconds time delay. A user-selectable setpoint for enable and disable is also provided.

When an unbalance condition is detected on Source 1, the Unbalance Timer (TD UNBAL) starts timing. After TD UNBAL times out, Source 1 is declared "failed".

For a 3-phase delta source, this feature should be turned off via the VOLT UNBAL setpoint.

**29. Alternate Transfer Modes of Operation**

Provides standard or optional transfer modes, mode selection devices, and operational methods for ATSSs.

**29J. Type of Operation (MANTR) Operation (new feature)**

This feature provides for a selection between an automatic transfer and re-transfer mode or a manual pushbutton re-transfer to Normal from the Emergency Source mode. If this option is not selected the factory default selection is automatic.

**32. Delayed Transition Transfer Modes for Open Transition Transfer Switches**

This feature provides delayed transition transfer modes for an open transition transfer switch. Often used in systems with inductive loads, a delayed transition transfer switch may prevent or reduce in-rush currents due to out of phase switching of inductive loads.

**32A. Time Delay Neutral**

This feature provides a time delay in the neutral position during the transfer and re-transfer operations during which both Source 1 and Source 2 are disconnected from the load circuit. The time delay is programmable and is the same for both transfer and re-transfer operations.

Adjustable 0 - 120 Seconds

**32F. In-Phase Transition**

Provides In-phase transition, which is a feature that will permit a transfer or re-transfer between 2 available sources that have a phase angle difference of 8 degrees or less. The In-phase transition feature includes permissible frequency difference and synchronization time setpoints. In the event source 1 and source 2 fail to synchronize within a specified amount of time, due to excessive phase angle difference or frequency difference, then the transfer will take place under delayed transition. Alarm relay will energize and failure will be logged into the transfer history as either "Sync Fail - Freq" or "Sync Fail - Phase" depending on whether the frequency difference or the phase difference was excessive. The adjustable frequency difference is 0.0 to 3.0 Hz.

**35. Pre-Transfer Signal**

This feature provides a signal to a remote device prior to a re-transfer operation. It provides one Form "C" contact (NO/NC) for interface with other equipment (typically elevator controls). The contacts close/open on a timed basis prior to transfer in either direction. After TDNE/TDEN times out, this relay closes and the Pre-transfer Timer (TPRE) starts timing. After the TPRE times out, the transfer proceeds by starting the TDN timer if enabled. The pre-transfer relay opens after the transfer is complete.

Adjustable 0 - 120 Seconds

**35A. Pre-transfer Signal with 1 N.O. and 1 N.C. Contacts**

This feature provides pre-transfer signal and includes 1 N.O. and 1 N.C. contact.

**36. Emergency Inhibit (new feature)**

This feature enables the Emergency inhibit control input to inhibit transfers to the Emergency Source. See Control Inputs section for more information.

**48F. RS-485 with Modbus Option**

Provides communications for the ATC-300+ via Modbus through an integrated RS-485 port. Registers are available to read back status, voltages, frequencies, and historical data. Registers are also available for transfer switch control. Setpoints may be read back and/or programmed via a pass-through command. See the ATC-300+ Modbus Communication Guide pn: 66A7787.

### 1.5.2.2 Optional Features

The following is a list of the optional features of the ATC-300+ Controller.

#### 12. Power Source Annunciation

This feature provides LEDs to give switch position and power source availability indications.

#### Overcurrent Trip Indication

Available only with integral Overcurrent Protection (Feature 16). (Shown on Automatic Transfer Controller Display.)

#### 12L. Source 1 Tripped (Requires Feature 16) Via ATC-300+ LDC-Based Display

The Automatic Transfer Controller LCD display will read "Lockout" if the Source 1 circuit breaker is in the "tripped" position.

#### 12M. Source 2 Tripped (Requires Feature 16) Via ATC-300+ LDC-Based Display

The Automatic Transfer Controller LCD display will read "Lockout" if the Source 2 circuit breaker is in the "tripped" position.

## Section 2: Hardware Description

### 2.1 General

The purpose of this section is to familiarize the reader with the ATC-300+ Controller hardware, its nomenclature, and to list the unit's specifications. The information presented is divided into the following three parts:

- Operator Panel;
- Rear Access Area; and
- Specification Summary.

### 2.2 Front (Operator) Panel

The front panel, depending on the installation, is normally accessible from the outside of a panel or door. The front panel provides a means to:

- Alert the user to specific conditions;
- Program the controller; and
- Set and monitor the operating parameters.

The ATC-300+ Controller front panel serves two primary functions: output and input. The output function consists of:

- A two-line, 16 character LCD display module
- Five LED outputs
  - 1 Unit Status
  - 2 Source 1 Available
  - 3 Source 1 Connected
  - 4 Source 2 Available
  - 5 Source 2 Connected

There are seven input functions accessible through the pushbuttons:

- 1 Help/Lamp Test
- 2 Engine Test
- 3 Step/Enter
- 4 Increase
- 5 Decrease
- 6 Alarm Reset
- 7 Bypass Time Delay



Figure 1. The ATC-300+ Controller Front Panel.

2.2.1 The Output Function Components

The Display

A 2-line, 16-character alphanumeric LCD Display module is used to display all ATC-300+ Controller monitored parameters, setpoints, and messages in easy to read formats. The display has a green high contrast background that allows clear visibility of any information displayed. The display is continuously lit for clear visibility under poorly lit or no light conditions.

Six different displays can be presented via the LCD Display:

- Status Display
- Source 1 Display
- Source 2 Display
- Time/Date Display
- History Display
- Setpoints Display

As a default when there are no active commands or timers being displayed, the display shows information from the source that is connected to the load. This is referred to as the "Home" screen.

Line 1:	Source 1 or 2	Metered Voltage
Line 2:	Date	Time

Example:	Source 1	480V
	1/20/06	3:35PM

See Section 3 for more detailed information.

The LEDs

Unit Status

The green Unit Status LED blinks at a rate of once per second while in the ATC-300 Controller is in the "Run" Mode. This indicates that the ATC-300+ has completed a self-diagnostic and system diagnostic cycle. The self-diagnostic cycle checks include the:

- Microprocessor operation and
- Memory operation.

The system diagnostic cycle checks include the:

- Output relay operation;
- Control input operation; and
- Transfer switch operation.

The Unit Status LED blinks at an increased rate while the ATC-300+ Controller is in the "Program" Mode.

Source 1 Available

The white Source 1 Available LED illuminates if the Source 1 power source meets the criteria to be considered "available". That is, when it is within its undervoltage/overvoltage/underfrequency/overfrequency/voltage unbalance/phase reversal (if applicable) setpoint ranges for the nominal voltage and frequency setting.

Source 1 Connected

The green Source 1 Connected LED illuminates when the Source 1 switching device and its associated position indicating auxiliary contact are closed.

Source 2 Available

The amber Source 2 Available LED illuminates if the Source 2 power source meets the criteria to be considered "available". That is, when it is within its undervoltage/overvoltage/underfrequency/overfrequency/voltage unbalance/phase reversal (if applicable) setpoint ranges for the nominal voltage and frequency setting.

Source 2 Connected

The red Source 2 Connected LED illuminates when the Source 2 switching device and its associated position indicating auxiliary contact are closed.

2.2.2 The Input Function Components

The Pushbuttons and Combinations

Help/Lamp Test Pushbutton

The Help/Lamp Test pushbutton serves two functions. If the Help/Lamp Test pushbutton is pressed when a message is present on the LCD Display, a detailed description of the message will appear. The detailed message description will scroll across the bottom of the display. The detailed description can be aborted by pressing Help/Lamp Test key a second time.

**ATC-300+ Automatic Transfer Switch Controller**

If the LCD Display is displaying the Home screen when the Help/Lamp Test key is pressed, all of the LED's will momentarily illuminate, then the following information will scroll across the display:

- Serial number of the ATC-300+ Controller;
- Hardware revision number (= parts list revision number);
- Software version and revision number;
- Feature code – a decodable string listing all optional features programmed in the ATC-300+ Controller; and
- Firmware version.

**Engine Test Pushbutton**

The Engine Test pushbutton allows the user to test the Source 2 (generator) engine. The engine test function can be set with the ATC-300+ Controller to one of three setpoint modes to allow flexibility in how the test is run:

- 0 No Load Engine Test;
- 1 Load Engine Test; or
- 2 Disabled.

The factory default is set to 0 - No Load Engine Test.

For complete information on the Engine Test function, see Section 5.7.

**Step/Enter Pushbutton**

The Step/Enter pushbutton allows the user to scroll through the information and setpoint displays. By pressing the Step/Enter pushbutton, the information on the LCD Display will advance through the voltage(s), frequency, and status condition of Source 1, then Source 2, then the time and date information, then the history information, then the setpoints. The information on the LCD Display advances one step through the displayed information cycle with each depression of the Step/Enter pushbutton.

**Increase Pushbutton**

The Increase pushbutton allows the user to increase the value of the setpoints. When ATC-300+ Controller is in the "Program" Mode (to change setpoint values), each time the Increase pushbutton is pressed, the value of the displayed item will increase by one.

**Decrease Pushbutton**

The Decrease pushbutton allows the user to decrease the value of the setpoints. When ATC-300+ Controller is in the "Program" Mode (to change setpoint values), each time the Decrease pushbutton is pressed, the value of the displayed item will decrease by one.

**Alarm Reset Function (Increase + Decrease Pushbuttons)**

Pressing the Increase and Decrease pushbuttons simultaneously will reset the Alarm function. In addition, if both pushbuttons are pressed simultaneously while viewing any of the historical logged values in the program mode, the value of the current item displayed resets to zero.

**Bypass Time Delay Function (Step/Enter + Help/Lamp Test)**

Pressing the Step/Enter and Help/Lamp Test pushbuttons simultaneously will bypass the TDNE or TDEN functions when they actively counting. The "Bypass TDNE/TDEN" function does not have a user accessible, programmable setpoint for enable or disable.

**2.3 Rear Access Area**

The rear access area of the ATC-300+ Controller is normally accessible from the rear of an open panel door (Figure 2).

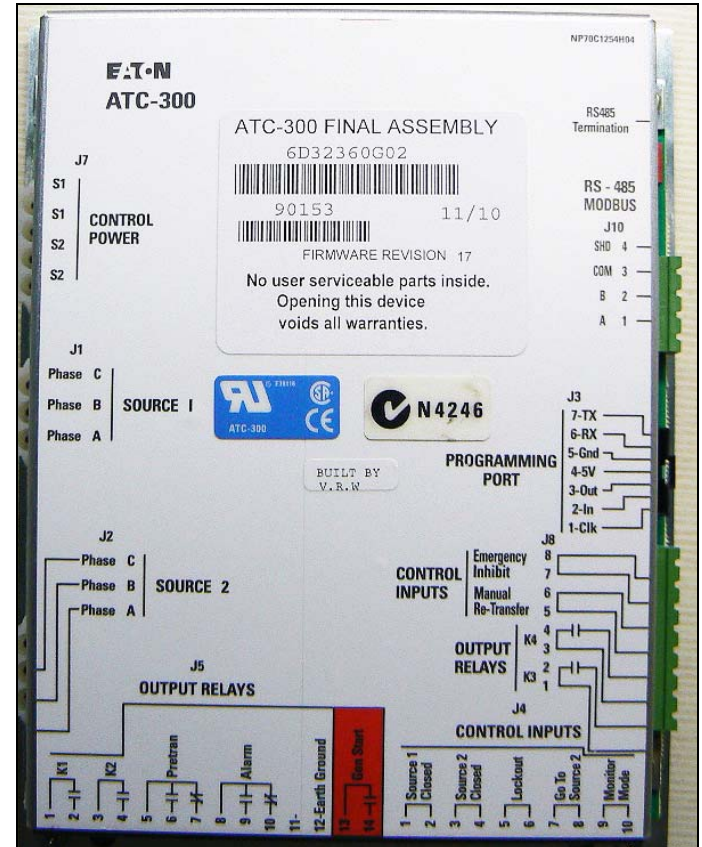

**Figure 2. ATC-300+ Controller (Rear View).**

All wiring connections to the ATC-300+ Controller are made at the rear of the chassis.

**Note:** To allow for uniform identification, the frame of reference when discussing the rear access area is with the panel door open and the User facing the back of the ATC-300+ Controller.

Located at the left rear of the chassis are connectors J1, J2, and J7. J1 and J2 provide for voltage monitoring of Source 1 and Source 2 respectively. J7 is provided for Sources 1 and Source 2 control power input. Located at the right rear of the chassis is the J3 programming port connector. The J4 and J5 connectors are located at the bottom of the controller. The J4 connector provides DC wetted connections for various control inputs. The J5 and J8 connectors provide dry relay contacts for primary control outputs.

See Section 5.5.1 for contact ratings.

## 2.4 Specification Summary

**Table 1. ATC-300 + Controller Specifications**

Input Control Voltage	65 to 145 Vac 50/60 Hz	
Voltage Measurements of	Source 1 VAB Source 1 VBC Source 1 VCA	Source 2 VAB Source 2 VBC Source 2 VCA
Voltage Measurement Range	0 to 790 Vac RMS (50/60 Hz)	
Voltage Measurement Accuracy	± 1% of Full Scale	
Frequency Measurements of	Source 1 and Source 2	
Frequency Measurement Range	40 Hz to 70 Hz	
Frequency Measurement Accuracy	± 0.3 Hz Over the Measurement Range	
Undervoltage Dropout Range: Breaker/Switch Style ATS Contactor Style ATS	50 to 97% of the Nominal System Voltage 78 to 97% of the Nominal System Voltage	
Undervoltage Pickup Range: Breaker/Switch Style ATS Contactor Style ATS	(Dropout + 2%) to 99% of the Nominal System Voltage (Dropout + 2%) to 99% of the Nominal System Voltage	
Overvoltage Dropout Range: Breaker/Switch Style ATS Contactor Style ATS	105 to 120% of the Nominal System Voltage 105 to 110% of the Nominal System Voltage	
Overvoltage Pickup Range: Breaker/Switch Style ATS Contactor Style ATS	103% to (Dropout -2%) of the Nominal System Voltage 103% to (Dropout -2%) of the Nominal System Voltage	
Underfrequency Dropout Range: Breaker/Switch Style ATS Contactor Style ATS	90 to 97% of the Nominal System Frequency 90 to 97% of the Nominal System Frequency	
Underfrequency Pickup Range: Breaker/Switch Style ATS Contactor Style ATS	(Dropout + 1Hz) to 99% of the Nominal System Frequency (Dropout + 1Hz) to 99% of the Nominal System Frequency	
Overfrequency Dropout Range: Breaker/Switch Style ATS Contactor Style ATS	103 to 110% of the Nominal System Frequency 103 to 105% of the Nominal System Frequency	
Overfrequency Pickup Range: Breaker/Switch Style ATS Contactor Style ATS	101% to (Dropout -1Hz) of the Nominal System Frequency 101% to (Dropout -1Hz) of the Nominal System Frequency	
Operating Temperature Range	-20 to +70°C (-4 to +158°F)	
Storage Temperature Range	-30 to +85°C (-22 to +185°F)	
Operating Humidity	0 to 95% Relative Humidity (Non-condensing)	
Operating Environment	Resistant to Ammonia, Methane, Nitrogen, Hydrogen, and Hydrocarbons	
Generator Start Relay	5 A, 1/6 HP @ 250 Vac 5 A @ 30 Vdc with a 150 W Maximum Load	
K1, K2, Pretransfer, Alarm Relays K3, K4	10 A, 1-3 HP @ 250 Vac 10 A @ 30 Vdc	
Applicable Testing	UL Recognized Component Meets UL 1008 Meets Intent of UL 991, Meets IEC 1000-4-2, 1000-4-3, 1000-4-4, 1000-4-5, 1000-4-6, 1000-4-11 Meets CISPR 11, Class A Complies with FCC Part 15, Class A	
Enclosure Compatibility	NEMA 1, NEMA 3R, and NEMA 12 UV Resistant ATC-300+ Faceplate	

**Section 3: Status Monitoring and Setpoints**

**NOTICE**

ALTHOUGH A WIDE VARIETY OF PARAMETERS AND SETPOINTS CAN BE DISPLAYED, THEY ARE NOT DISPLAYED IF THEY WERE NOT ORIGINALLY ORDERED AND PROGRAMMED.

**NOTICE**

WHETHER VIEWING OR PROGRAMMING, THE DISPLAY RETURNS TO THE HOME SCREEN IF NO PUSHBUTTON ACTIVITY IS DETECTED FOR APPROXIMATELY 2.5 MINUTES.

**3.1 Status Display**

The Status Display provides messages regarding anything that is presently changing or happening to the ATS's status, including source information, timer countdown, and failure reports. Refer to Appendix A for a complete list of Status Display messages.



Figure 3. The LCD Display.

**3.1.1 Source 1 and Source 2 Displays**

The Source 1 and Source 2 displays indicate the present status of the sources in terms of voltage and frequency. If the source is available, the condition display will be "SOURCE 1 GOOD" or "SOURCE 2 GOOD". If it is unavailable, one of the following possible conditions will be shown:

SOURCE 1 U-V                      SOURCE 2 U-V

The source voltage has dropped below the dropout setting and not risen above the pickup setting.

SOURCE 1 O-V                      SOURCE 2 O-V

The source voltage has risen above the dropout setting and not dropped below the pickup setting.

SOURCE 1 U-F                      SOURCE 2 U-F

The source frequency has dropped below the dropout setting and not risen above the pickup setting.

SOURCE 1 O-F                      SOURCE 2 O-F

The source frequency has risen above the dropout setting and not dropped below the pickup setting.

SOURCE 1 UNBAL                      SOURCE 2 UNBAL

The voltage unbalance has risen above the dropout setting and not dropped below the pickup setting.

S1 PHASE REVERSE                      S2 PHASE REVERSE

The phase sequence does not agree with the setpoint value, indicating that the phase sequence is reversed.

**3.1.2 Time/Date Display**

The Time/Date Display indicates real time in terms of hours, minutes, and seconds; and month, day, and year. It also indicates individual time and date items for programming purposes. The day of the week can also be set with 1 = Sunday, 2 = Monday, etc. The time, date, and day of the week can be set in the Program Mode.

**3.1.3 History Display**

The History Display indicates historical and cumulative counter values as follows:

**Engine Run Time**

This counter will log the generator run time in hours. Time will start being logged at the time the GEN START contacts are closed, and it will stop as soon as they are opened. This counter will count up to 9999 hours and then turn over to 0000. It can be reset to zero in the Program Mode.

**Source 1 Connected Time**

This counter logs the time in hours that Source 1 has been connected to the load. Time will be logged while the SOURCE 1 CLOSED control input is in the "connected" state. This counter will count up to 9999 hours and then turn over to 0000. It can be reset to zero in the Program Mode.

**Source 2 Connected Time**

This counter logs the time in hours that Source 2 has been connected to the load. Time will be logged while the SOURCE 2 CLOSED control input is in the "connected" state. This counter will count up to 9999 hours and then turn over to 0000. It can be reset to zero in the Program Mode.

**Source 1 Available Time**

When Source 1 meets the voltage and frequency setpoint criteria, this counter logs the time in hours. This counter will count up to 9999 hours and then turn over to 0000. It can be reset to zero in the Program Mode.

**Source 2 Available Time**

When Source 2 meets the voltage and frequency setpoint criteria, this counter logs the time in hours. This counter will count up to 9999 hours and then turn over to 0000. It can be reset to zero in the Program Mode.

**Load Energized Time**

When either of the two sources is connected to the load and the connected source is available, this counter will start logging the time in hours. This counter will count up to 9999 hours and then turn over to 0000. It can be reset to zero in the Program Mode.

**Total Number of Transfers**

This counter logs the number of transfer cycles that occur. This counter will count up to 9999 cycles and then turn over to 0000. It can be reset to zero in the Program Mode.

**Reason/Date/Time for the 16 Most Recent Transfers**

The 16 most recent transfer events are stored in history and may be viewed at the LCD Display as follows:

- Use the Step/Enter pushbutton to step to the "TRANSFER HISTORY" message.
- Press the Increase pushbutton to display the most recent transfer event (T01) along with the type and cause of the event.
- Press the Decrease pushbutton to display the date and time of the event. Continually pressing the Decrease pushbutton will cycle the display between the event display and the date/time of event display.
- Press the Increase pushbutton to display the next most recent transfer event (T02).
- Pressing the Step/Enter pushbutton, while viewing any of the transfer history displays, will exit the Transfer History displays.

**3.1.4 Setpoints Display**

The Setpoints Display indicates presently programmed setpoints. The setpoints can be altered with valid password entry. Keep in mind; if an optional ATC-300+ Controller feature was not originally ordered and programmed, it will not be displayed. Refer to Section 6 for more details on setpoints.

**3.1.5 Help Display**

This display presents moving language messages, explanations, and prompts to assist the operator. When the Help/Lamp Test Pushbutton is pressed and released a second time during the scrolling of a message, the message is aborted.

## Section 4: Typical Function of the ATC-300+ Controller

The ATC-300+ Controller operates as follows.

The input connections of the ATC-300+ controller are wetted and work on an opening or closure of an external contact. The output connections are dry contacts and function depending on input connections and / or source availability.

120 Vac, 60 Hz is required to power the ATC-300+ controller. Power is supplied to either pins 1 and 2 or 3 and 4 on the J-7 connector.

Source 1 (S1) sensing is supplied on the J-1 connector; Source 2 (S2) sensing is supplied on the J-2 connector.

K1 and K2 relays, located on pins 1 and 2 (K1) or pins 3 and 4 (K2) on the J-5 connector, along with the K3 and K4 relays, located on pins 1 and 2 (K3) and pins 3 and 4 (K4) on the J8 connector, are used to control device position. S1 and S2 inputs are located on pins 1 and 2 (S1) or pins 3 and 4 (S2) on the J-4 connector and are used to sense device position.

K1 and K3 close until the S1 input is satisfied but no longer than 6 seconds before the S1 device Alarm is triggered and the K1 and K3 relays are deenergized. The K2 and K4 relays function the same as the K1 relay in that they close until the S2 input is satisfied (closed) but no longer than 6 seconds before the S2 device Alarm is triggered and the K2 and K4 relays are deenergized. Either input **MUST** be satisfied prior to resetting the Alarm. The S1 and S2 connected inputs are wetted inputs that require a contact closure in order to be satisfied.

The S1 device Alarm will occur if the switch is commanded to go from S1 to S2 and the S1 connected input is **NOT** removed within 6 seconds after the command to transfer. The S1 device Alarm will also occur if the switch is commanded to go from S2 to S1 and the S1 connected input is **NOT** connected within 6 seconds after the command to transfer from the neutral position. That is the K2 relay closes **AFTER** TDNE or after TD PRE-TRAN times out, if the S1 connected input is **NOT** opened within 6 seconds the K2 relay will open and an S1 device error message, "SOURCE 1 DEVICE", will be displayed.

A typical transfer request will begin with an S1 outage (S1 becomes unavailable per the programmed setpoints), Engine Test, or Plant Exercise function. After TDES, if programmed, counts down, the Generator Start contact will close. For a Plant Exercise or Engine Test, the S2 available light **MUST** become available within 90 seconds or the generator start contacts will reopen. Once S2 meets the requirements to be considered available, then TDNE, if programmed, will time down. The pretransfer relay will energize if S1 is available. TD PRE-TRAN will time down if programmed and if S1 is available (Engine Test or Plant Exercise). The K2 relay will energize. The S1 connected input **MUST** open within 6 seconds (see above). K2 will open IF TDN is programmed. TDN will then time down and K2 and K4 will energize until the S2 connected input is closed (this **MUST** happen within 6 seconds of K2/K4 closure or the S2 device alarm will trigger and the K2 and K4 relays will deenergize). Once the S2 connected input is satisfied, K2 and K4 will open and the pretransfer relay will de-energize.

When S1 returns and becomes available per the programmed setpoints, TDEN, if programmed, will time out. The pretransfer relay will energize. TD PRE-TRAN, if programmed, will time out. K1 will energize for no longer than 6 seconds or until the S2 connected input is removed. If the 6 seconds times out, then an S2 device Alarm will trigger and K1 will open. Once the input is removed, then K1 will open if TDN is programmed. TDN will time down and K1 and K3 will reclose until the S1 input is satisfied, but for no longer than 6 seconds. If the 6 seconds is reached, then an S1 device Alarm will be triggered and the K1 and K3 relays will open. If the S1 connected input is satisfied, then K1 will open, the pretransfer relay will de-energize, and TDEC will time down and open the engine start contact.

The Go To Source 2 input (normally closed, open to initiate) causes the Engine Start contacts to close. Once the S2 sensing satisfies the setpoints programmed, then a transfer is initiated. The transfer functions as described above. The controller will maintain the Engine Start contacts and the S2 connected as long as the Go To Source 2 input is maintained. Once it is removed, a retransfer to S1, if S1 is available per the setpoints, will occur and functions as described above. "Go To Source 2" is displayed on the controller.

The Monitor Mode input (normally open, close to initiate) is utilized to put the controller in a "Monitor" only state. No other inputs will affect the operation of the controller when the Monitor Mode input is initiated. The controller will **ONLY** monitor the voltage and frequency of the S1 and S2 inputs. Changing of the setpoints of the controller **MAY** be accomplished while in Monitor Mode. All setpoints are accessible and all timers can be reset. "ATS Not In Automatic" is displayed on the controller.

The Lockout input (normally closed, open to initiate) is utilized to place the controller in a state where it will **NOT** supply any outputs regardless the inputs. It is used to monitor the state of any fault indicating devices. If the fault device trips due to an over current or over load condition, then a contact opening will place the controller in the Lockout state. The Alarm contact will change state when the lockout signal is sensed. "Lockout" is displayed on the controller. The fault indicating device **MUST** be reset before the controller can be reset or the Alarm will continue to indicate.

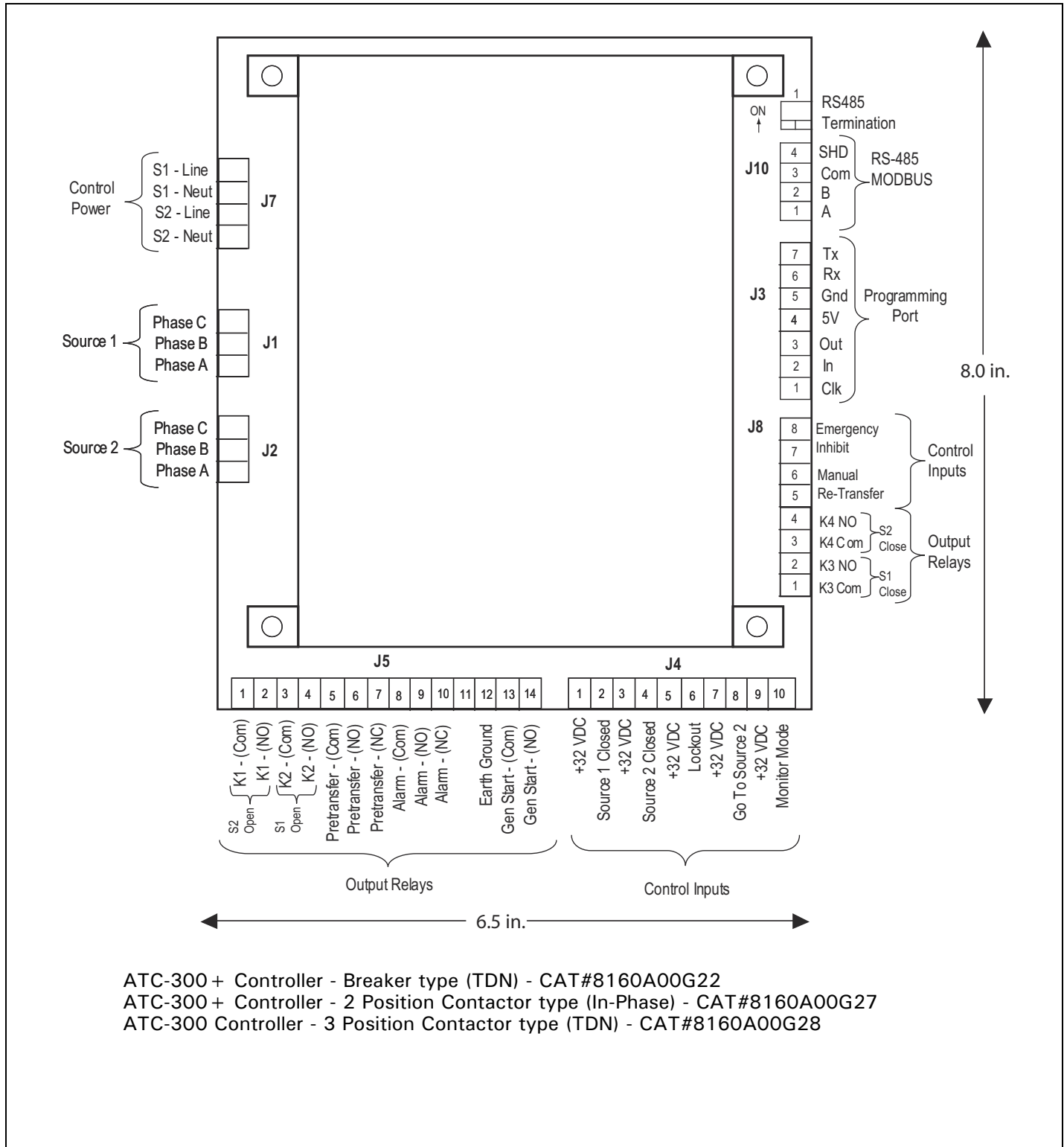

ATC-300+ Controller - Breaker type (TDN) - CAT#8160A00G22  
 ATC-300+ Controller - 2 Position Contactor type (In-Phase) - CAT#8160A00G27  
 ATC-300 Controller - 3 Position Contactor type (TDN) - CAT#8160A00G28

Figure 4. Connectors on the ATC-300+ Controller.

## Section 5: Operation

### 5.1 General

This section specifically describes the operation and functional use of the ATC-300+ Controller. The practical use of and operation within each category will be discussed. In this section, it is assumed that prior sections of this manual were reviewed and that the operator has a basic understanding of the hardware.

### 5.2 Automatic Mode

The Automatic Mode of the ATC-300+ Controller provides for automatic transfer and re-transfer from Source to Source as dictated by the features supplied and their programmed setpoint values. It provides a summary of the ATC-300+ Controller intelligence and supervisory circuits that constantly monitor the condition of both the Source 1 and Source 2 power sources, thus providing the required intelligence for transfer operations. These circuits, for example, automatically initiate an immediate transfer of power when the power fails or the voltage level drops below a preset value. Exactly what the ATC-300+ Controller will initiate in response to a given system condition depends upon the combination of standard and selected optional features.

### 5.3 Monitor Mode

Monitor Mode is a special operating mode in which the ATC-300+ Controller does not provide control for transfer operations. The ATC-300+ will, however, continuously monitor both Source 1 and Source 2 voltages and frequencies.

The ATC-300+ will be in Monitor Mode when the "Monitor Mode" control input is in the "Connected" state as described in Section 5.4. While in the Monitor Mode of operation, the ATC-300+ LCD Display will display "ATS NOT IN AUTOMATIC".

### 5.4 Control Inputs

The ATC-300+ has five individual input control signals. The inputs are DC wetted with the unregulated DC supply and appropriate current limiting to provide a nominal current of 10 mA per channel.

#### 5.4.1 Control Input Descriptions

The Control Input "State" definitions are as follows.

**Connected** - When the input is shorted by an external contact or connection.

**Unconnected** - When the input is NOT shorted by an external contact or connection.

The Control Input operations are defined as follows.

#### Source 1 Closed

When this input is in the "Connected" state, it indicates to the ATC-300+ Controller that the Source 1 device is closed. When this input is in the "Unconnected" state, it indicates to the ATC-300+ that the Source 1 device is open. This input is typically wired to the Source 1 device auxiliary contact that is closed when the Source 1 device is closed. The "Source 1 Closed" input is always enabled.

#### Source 2 Closed

When this input is in the "Connected" state, it indicates to the ATC-300+ Controller that the Source 2 device is closed. When this input is in the "Unconnected" state, it indicates to the ATC-300+ that the Source 2 device is open. This input is typically wired to the Source 2 device auxiliary contact that is closed when the Source 2 device is closed. The Source 2 input is always enabled.

#### Lockout

When the "Lockout" input is in the "Unconnected" state, the ATC-300+ Controller will not permit an automatic transfer operation. When the "Lockout" input is in the "Unconnected" state, the LCD Display will be active continuously. It will read "Lockout" on Line 2 of the LCD Display screen immediately, regardless of any controller or switching device operation. When the "Lockout" input is in the "Connected" state and the Alarm is reset, the ATC-300+ will permit automatic transfer operation. This input is typically wired to the normally closed Source 1 and Source 2 device alarm contact that opens when one of the devices has tripped due to a fault current. The "Lockout" input is selectable as enabled or disabled via factory control only.

#### Go To Source 2

When the "Go to Source 2" input is in the "Connected" state, the ATC-300+ Controller is in a normal, automatic operation mode. When the "Go To Source 2" input is in the "Unconnected" state, the ATC-300+ controller will initiate a generator start and then transfer to the Source 2 power source. The ATC-300+ will maintain the connection to Source 2 until the input changes to the "Connected" state, upon which it will initiate a re-transfer to the Source 1 power source. When the "Go To Source 2" input is in the "Unconnected" state, the LCD Display will be active continuously. Active time delays will be constantly displayed on Line 1, with real-time remaining countdown to zero status. It will constantly read "Go To Source 2" on Line 2 of the LCD Display. This operation is "failsafe". The "Go To Source 2" input is always enabled. The "Go To Source 2" input does not have a user accessible programmable setpoint for enable or disable.

#### Monitor Mode

When the "Monitor Mode" input is in the "Unconnected" state, operation of the ATC-300+ Controller will not be effected. When the "Monitor Mode" input is in the "Connected" state, the ATC-300+ will monitor the Source 1 and Source 2 voltages and frequencies but will not provide any control capabilities. When the "Monitor Mode" input is in the "Connected" state, the ATC-300+ LCD Display will be active continuously and will constantly read "ATS" on Line 1 and "NOT IN AUTOMATIC" on Line 2 of the LCD Display. The "Monitor Mode" input is selectable as enabled or disabled via factory control. The "Monitor Mode" input does not have a user accessible programmable setpoint for enable or disable. This is NOT a "failsafe" operation.

#### Manual Re-Transfer

With manual operation set, momentary closure on Pins 5 and 6 of Connector J8 allows ATC-300+ to proceed with a re-transfer operation at the operators discretion. Should a failure of the emergency source occur while waiting for the manual return, the re-transfer proceeds automatically.

**Emergency Inhibit**

This input is located on Pins 7 and 8 of Connector J8 and is enabled when the Emergency Inhibit optional feature (36) is enabled. The contact is closed for normal operation. Opening this contact will activate the Emergency Inhibit input.

If the Emergency Inhibit contact is opened when the load is connected to the Normal Source, no action will be taken if the Normal Source is available. If the Normal Source is not available, an immediate transfer to the neutral position will occur.

If the Emergency Inhibit contact is opened when the load is connected to the Emergency Source, the ATC-300+ will transfer the load to the Normal Source if it is available. If the Normal Source is not available, an immediate transfer to the neutral position will occur.

The Emergency Inhibit input is only active when either Source 1 or Source 2 is preferred. This input is not active when the Preferred Source selection is set to None.

The Emergency Inhibit input takes priority over the Go To Emergency input if both inputs are activated at the same time. In this case, the generator will start but a transfer to the Emergency Source will be inhibited until the Emergency Inhibit input is deactivated.

**5.5 Output Relay**

The primary control outputs of the ATC-300+ Controller are dry relay contacts. These relays are comprised of one latching “Form A” relay to provide the generator start contacts, and six conventional coil “Form C” relays (four of which implement only the Form A contact) necessary to complete the electrical control function. Since the outputs were tested per the UL 1008 Dielectric Test, the dielectric rating for each output is a minimum of 1500 Vac. The output relays are pulsed to eliminate error caused by software “races” between Lockout and Source 1 or Source 2 Closed inputs.

The latched coil relay is UL/CSA rated at 5 A, 1/6 HP, 250 Vac. The DC rating is 5 A, 30 Vdc, with a 150 W maximum load. The remaining conventional relays are UL/CSA rated at 10 A, 1/3 HP, 250 Vac. The DC rating is 10 A at 30 Vdc.

**Note:** The ATC-300+ Controller MUST BE properly grounded at J-5, Pin 12 for proper operation.

The Output Relay functions are divided into two categories:

- Customer Connections and
- Transfer Operation Contacts.

**5.5.1 Output Relay Descriptions**

Specifically the relay functions are as follows.

**5.5.1.1 Customer Connections**



**CAUTION**

**THE ATC-300+ CONTROLLER MUST BE PROPERLY GROUNDED AT J-5, PIN 12 FOR PROPER OPERATION.**

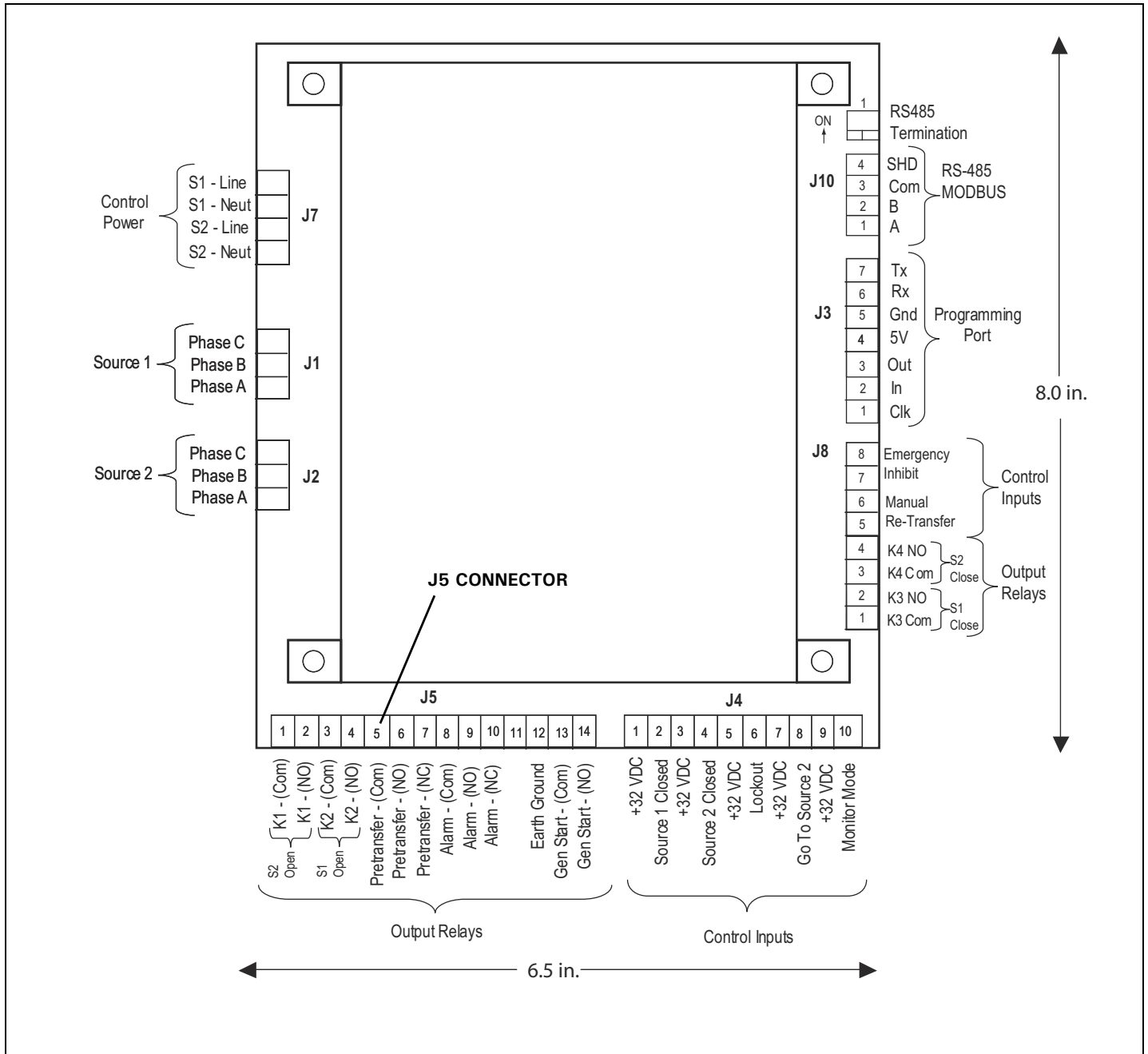

**Figure 5. Connector Output Relay Connections.**

**Generator Start Relay**

This latching relay is the generator start relay for system configurations that employ a generator as the Source 2 power source. This relay provides a Form A contact of silver alloy with gold flashing for closure of the generator start circuit.

The Form A contact is implemented with the Common Pin (J-5, Pin 13) and the Normally Open Pin (J-5, Pin 14). The generator start relay contacts are rated for 5 A, 1/6 HP @ 250 Vac. The DC rating is 5 A @ 30 Vdc with a 150 W maximum load.

**Alarm Relay**

The alarm relay is de-energized to indicate an absence of an alarm state and energized to indicate the presence of an alarm condition. Alarm conditions include the following.

1. Improper circuit breaker (or contactor) operation (breaker [or contactor] fails to open or close within six [6] seconds)
2. Motor operator failure (Breaker Type ATS only)
3. Lockout
4. Failsafe condition
5. Aborted engine test due to Source 2 unavailability
6. Aborted plant exerciser test due to Source 2 unavailability
7. Unsuccessful in-phase transition

The alarm relay will remain energized until "Alarm Reset" is pressed.

The full Form C contact of this relay may be wired to an alarm annunciator panel to indicate a problem with the ATS. The full Form C contact of this relay is implemented with the Common Pin (J-5, Pin 8), the Normally Closed Pin (J-5, Pin 10), and Normally Open Pin (J-5, Pin 9). The alarm relay contacts are rated for 10 A, 1-3 HP @ 250 Vac. The DC rating is 10A @ 30 Vdc.

**Pre-transfer Relay**

This Form C relay opens/closes on a timed basis (adjustable from 1 to 120 seconds) prior to the transfer operation between two available sources to allow the load to be de-energized prior to transfer in either direction. After TDNE/TDEN times out, this relay energizes and the Pre-transfer timer (TD PRE-TRAN) starts timing. After TD PRE-TRAN times out, the transfer proceeds. The pre-transfer relay de-energizes after the transfer is complete.

The full Form C contact of this relay is implemented with the Common Pin (J-5, Pin 5), the Normally Closed Pin (J-5, Pin 7), and the Normally Open Pin (J-5, Pin 6). The pre-transfer relay contacts are rated for 10 A, 1-3 HP @ 250 Vac. The DC rating is 10 A @ 30 Vdc.

**5.5.1.2 Transfer Operations Connections**

K1, K2, K3, and K4 are factory wired to operate the transfer switch. The relay contacts for each are rated for 10 A, 1/3 HP @ 250 Vac. The DC rating is 10 A @ 30 Vdc. K1 - K4 are Form C relays but only the Form A contacts are used to operate the transfer switch.

**Note:** The ATC-300+ Controller MUST BE properly grounded at J-5, Pin 12 for proper operation.

**Output Relay K1**

This Form A relay is used for control of the transfer switch motor to close the Source 1 breaker/switch for breaker/switch style transfer switches. The K1 relay momentarily energizes until the ATC-300+ senses that the Source 1 breaker/switch is closed, then K1 de-energizes. For contactor style transfer switches, this relay opens the Source 2 contactor via its trip coil. The K1 outputs are common pin (J-5, pin 1) and Normally Open pin (J-5, pin 2).

**Output Relay K2**

This Form A relay is used for control of the transfer motor to close the Source 2 breaker/switch for breaker/switch style transfer switches. The K2 relay momentarily energizes until the ATC-300+ senses that the Source 2 breaker/switch is closed, then K2 de-energizes. For contactor style transfer switches, this relay opens the Source 1 contactor via its trip coil. The K2 outputs are common pin (J-5, pin 3) and Normally Open pin (J-5, pin 4).

**Output Relay K3**

This Form A output is used for control of the close coil of the Source 1 contactor for contactor style switches. The K3 relay momentarily energizes until the ATC-300+ senses that the Source 1 contactor is closed, then K3 de-energizes. The K3 outputs are common pin (J-8, pin 1) and Normally Open pin (J-8, pin 2).

**Output Relay K4**

This Form A output is used for control of the close coil of the Source 2 contactor for contactor style switches. The K4 relay momentarily energizes until the ATC-300+ senses that the Source 2 contactor is closed, then K4 de-energizes. The K4 outputs are common pin (J-8, pin 3) and Normally Open pin (J-8, pin 4).

**5.6 Operating Voltage and Measurements**

The ATC-300+ Controller operates with control power from 65 to 145 Vac. The ATC-300+ operates on single and three phase systems with selectable frequency settings of 50 or 60 Hz depending on the system ordered.

The ATC-300+ can perform the time delay engine start function without control power. This is accomplished by the use of a supercap and a latching control relay. The supercap stays charged for several minutes to power the logic circuitry that provides the start pulse to the latching control relay. The latching control relay, which controls the generator, only changes state when it receives start or stop pulses. The coil voltage for the latching relay comes from another capacitor that also stays charged for several minutes.

The ATC-300+ Controller operates directly from the line sensing inputs of the Source 1 and Source 2 power sources. The nominal operating system inputs are from 120 to 600 Vac. The standard system assumes that neutral is available and that the transfer mechanism can therefore be powered from an available 120 Vac source. If a neutral conductor is not available, a 120 Vac supply is created by an external transformer.

All voltage monitoring and measurements are true RMS measurements.

## 5.7 Engine Test

The Engine Test is intended to permit the periodic performance of tests of the system. The exact test conditions are determined by the programmed setpoints. The operator-selected parameters include setting the engine run time and the Test Mode. Refer to Table 2 for test programming details.

There are three test modes:

- 0 No Load Engine Test;
- 1 Load Engine Test; or
- 2 Disabled.

The factory default is set to 0 - No Load Engine Test

**Note:** If the Source 2 power source is not programmed as a generator, this function will be inactive.

### NOTICE

**IF THE ATS IS UNABLE TO PROCESS A ENGINE TEST REQUEST DUE TO THE ATS STATUS, THE REQUEST IS IGNORED.**

When the Engine Test pushbutton is pressed, the following message will appear on the LCD Display:

```
Line 1: Password 0 0 0 0
Line 2: Use Inc/Dec & Step
```

After entering the 4-digit password and pressing the Step/Enter pushbutton, the ATC-300+ will display the Time Delay on Engine Starting (TDES) timer countdown. Once the TDES countdown reaches zero, the ATC-300+ Controller will initiate an engine start. The engine run duration will be per the Engine Run Test Time setpoint.

If the (0) No Load Engine Test Mode has been selected, the transfer from Source 1 to Source 2 will not occur. If the (1) Load Engine Test Mode has been selected, the transfer from Source 1 to Source 2 will occur after the generator output has reached the specified setpoints. If the (2) Disabled Mode has been selected, or if the "Number of Generators" setpoint is programmed to zero, the Engine Test will not occur.

All enabled and programmed time delays will be performed per the setpoints during an engine test. The time delays will appear on the LCD Display with "countdown to zero" when active. Depending on the setpoints and the optional features selected with the ATC-300+ Controller, these can include:

- TDES;
- Time Delay Normal to Emergency (TDNE);
- Time Delay Emergency to Normal (TDEN);
- Time Delay for Engine Cooldown (TDEC);
- Time Delay Neutral (TDN); and
- Pre-transfer Delay Signal (TD PRE-TRAN).

All operations are "Failsafe", that is they prevent disconnection from the only available power source and also force a transfer or re-transfer operation to the only available power source.

During an engine test, if the Engine Test pushbutton is pressed a second time before the Engine Test is complete and correct password has been entered; the Engine Test will be terminated. An engine test may also be aborted in the following ways:

1. If the Emergency Source does not become available within 90 seconds of the ATC-300+ providing the engine start command;
2. If, during the TDNE countdown, the Emergency Source goes unavailable more than three times (Each time, TDNE will restart);
3. If the Emergency Source is powering the load and it goes unavailable for more than the TDEF setting; and
4. If the Normal source becomes unavailable.

When an engine test is aborted due to an unavailable source during TDNE countdown, the Alarm relay will energize, a "TEST ABORTED" message will appear on the display, and the event will be logged into the Transfer History as "Aborted Test".

## 5.8 Plant Exerciser

### NOTICE

**THE PLANT EXERCISER FEATURE ALLOWS FOR AUTOMATIC PROGRAMMING OF THE DESIRED TEST CYCLE ON A DAILY, 7-DAY, 14-DAY, OR 28-DAY BASIS. IF THE ATS IS UNABLE TO PROCESS A PLANT EXERCISER REQUEST DUE TO THE ATS STATUS, THE REQUEST IS IGNORED.**

The plant exerciser is a feature that provides an automatic test of the generator. The test can be run daily, every 7 days, every 14 days, or every 28 days with durations equal to the programmed engine test time. Two optional modes of plant exercising are available:

- No Load Exercise; and
- Load Exercising with "Failsafe".

The ATC-300+ Controller allows the user to program the exact day, hour, and minute that the Plant Exercise will occur. This allows for the Plant Exercise to take place at the most opportune time for the specific facility.

The hour and minute that the Plant Exerciser is performed are programmed with the "PE HOUR" and "PE MINUTE" setpoints where "PE HOUR" is in military time (1:00 PM = 13:00) and the "PE MINUTE" can be set from 0 to 59. The test day is programmed with the "PE DAY" setpoint. The ATC-300+ Controller compares the "PE DAY" setpoint with the "WEEKDAY" setting, which is set along with the time and date. If a 7-day plant exercise is programmed, the selections are from "1 SUN" through "7 SAT".

If a 14-day plant exercise is programmed, the "PE DAY" setpoint can be set from "1 SUN" to "14 SAT" where "1 SUN" is the first Sunday of the 14-day period and "14 SAT" is the second Saturday of the 14-day period.

If a 28-day plant exercise is programmed, the "PE DAY" setpoint can be set from "1 SUN" to "28 SAT" where "1 SUN" is the first Sunday of the 28-day period and "28 SAT" is the fourth Saturday of the 28-day period.

If desired, the Plant Exerciser can be disabled by choosing "OFF" for the "Plant Exer-" setpoint.

Plant Exercising in the Load Exercising Mode is "Failsafe". If the generator fails during testing for any reason, the ATC-300+ will signal the transfer switch to return to the Source 1 power source. The ATC-300+ will display "FAILSAFE" until a pushbutton is pressed.

### 5.9 In-phase Transition (Optional Feature 32F)

The In-phase transition feature permits a transfer or re-transfer only between 2 available sources that have a phase angle difference of eight (8) degrees or less. The In-phase transition feature includes user-adjustable permissible frequency difference setpoint (0.0 - 3.0 Hz) and a programmable Sync timer. The Sync times will count down and be displayed while waiting for the two sources to synchronize.

In-phase transition is an open transition with both sources in-phase. An anticipatory scheme is used for controlling the circuit breakers. The advance angle is calculated based on the frequency difference between the two sources and also the response time of the breaker. This results in the optimum reconnect angle of 0 degrees for all of the frequency difference values.

Both sources must be available and the frequency difference must be less than the in-phase transition frequency difference setpoint (0.0 to 3.0 Hz). When these conditions are met, the ATC-300+ Controller will monitor the phase difference between the two sources. The synchronization timer will count down and be displayed as "SYNC TIME" while waiting for synchronization to be detected. When the phase difference is within the advance angle window, the "transfer" command is given. This is an open transition but both sources will be in-phase when the transfer occurs.

In the event source 1 and source 2 fail to synchronize within a specified amount of time, due to excessive phase angle difference or frequency difference, then the transfer will take place under delayed transition. Alarm relay will energize and failure will be logged into the transfer history as either "Sync Fail - Freq" or "Sync Fail - Phase" depending on whether the frequency difference or the phase difference was excessive.

### 5.10 Program Mode

The ATC-300+ Controller is fully programmable from the device's faceplate once the Password has been correctly entered. Any operator associated with programming the ATC-300+ Controller will quickly discover that ATC-300+ programming is just a matter of simple, repetitive steps. However, because of the importance placed on this function and its critical relationship to the proper functioning of the system, Section 6 of this manual is dedicated to the Program Mode. Refer to that section and Table 2 for details.

## Section 6: Programming

### 6.1 Introduction

**NOTICE**

**ALTHOUGH ALL ATC-300 CONTROLLER PROGRAMMABLE FEATURES ARE ADDRESSED IN THIS SECTION, ONLY THOSE ORDERED BY THE CUSTOMER AND INITIALLY PROGRAMMED AT THE FACTORY WILL APPEAR IN THE DISPLAY FOR PROGRAMMING CHANGES IN THE FIELD.**

The ATC-300 Controller is fully programmable from the device's faceplate or remotely through the communications port. Users can reprogram setpoints as well as other parameters. The time, date, and setpoints can only be changed while the device is in the Program Mode.

Program Mode is achieved by entering a valid password when prompted by the Setpoints screens. The Unit Status LED will blink at a faster rate when viewing the setpoints while in Program Mode.

**NOTICE**

**WHILE IN THE PROGRAM MODE, THE ATC-300+ CONTROLLER IS NEVER OFF-LINE AND CONTINUES TO FUNCTION IN ACCORDANCE WITH PREVIOUSLY PROGRAMMED SETPOINTS.**

### 6.2 Password

To enter the Program Mode, the ATC-300+ Controller requires a password to prevent unauthorized persons from modifying setpoint values.

There are five screens related to the password, which is a four-digit number from 0000 to 9999.

1. 

VIEW SETPOINTS?	YES
-----------------	-----

Use the Increase or Decrease pushbuttons to select Yes, then use the Step/Enter pushbutton to enter the selection and move to the next screen

2. 

CHANGE SETPOINTS?	YES
-------------------	-----

Use the Increase or Decrease pushbuttons to select Yes or No, then use the Step/Enter pushbutton to enter the selection and move to the next screen. If No is selected, the user will be able to review the setpoints but not make any changes. If Yes is selected, the Password screen will appear.

3. 

PASSWORD (Use Inc/Dec)	0000
---------------------------	------

Use the Increase or Decrease keys to scroll to the desired value (0 - 9) for the first digit, then use the Step/Enter key to enter the value and move to the next digit. Repeat for remaining three digits. After all four numerals of the password are entered, press the Step/Enter pushbutton to enter the password and proceed to the next screen. If an invalid password is entered, the LCD Display shall read "Invalid Password" and the user must press the Step/Enter pushbutton to initiate another password entry sequence.

**Note:** The factory default password is "0300". If the password is forgotten, contact the factory for the backdoor password.

## ATC-300+ Automatic Transfer Switch Controller

4. 

CHANGE PASSWORD?	YES
---------------------	-----

Use the Increase or Decrease pushbuttons to select Yes or No, then use the Step/Enter pushbutton to enter the selection and move to the next screen. If No is selected, the first Setpoint screen will appear. If Yes is selected, the following screen will appear.

5. 

NEW PASSWORD	0000
(Use Inc/Dec)	

Use the Increase or Decrease pushbuttons to scroll to the desired value (0 - 9) for the first digit of the new password, then use the Step/Enter pushbutton to enter the value and move to the next digit. Repeat for remaining three digits.

The user then steps through the setpoint screens and can change the setpoint values. During this time, the Unit Status LED will blink at a faster rate. At the end of the setpoint screens, the user will be prompted to save the setpoints.

### 6.3 Display Only Mode

In the Display Only Mode, the ATC-300+ Controller allows the user to view all setpoints and their programmed values. Each press of the Step/Enter pushbutton will advance the program to the next setpoint. Setpoint values CANNOT be changed while in the Display Only Mode.

### 6.4 Change Setpoints Mode

In the Change Setpoints Mode, the user can step through the Setpoint screens and change the Setpoint values using the Increase and Decrease pushbuttons. During this time, the Unit Status LED will blink at a faster rate to indicate Program Mode. At the end of the setpoint screens, the LCD Display will read Save Setpoints? Either the Increase or Decrease pushbutton may be used to select either Yes or No". The Step/Enter pushbutton is then pressed to enter the selection. If Yes is selected at the Save Setpoints? Screen, the ATC-300+ shall save the Setpoint settings and the LCD Display shall read Programming Setpoints to confirm entry. If "No" is selected, then all Setpoints will remain unchanged.

### 6.5 Programmable Features and Setpoints



**CHANGING THE SYSTEM NOMINAL VOLTAGE OR FREQUENCY SETPOINT WILL AUTOMATICALLY CHANGE ALL THE PICKUP AND DROPOUT SETTINGS TO THE NEW DEFAULT VALUES.**

---

All ATC-300+ Controller programmable features and associated setpoint possibilities with any required explanations are presented in Table 2. Remember that only features originally ordered and factory programmed will appear in the display.

The following setpoints are programmable if the corresponding feature is programmed.

**Table 2. Programmable Features and Setpoints**

SETPOINT	SETPOINT UNITS	DESCRIPTION	RANGE	FACTORY DEFAULT
New Password	Four Digits	Set New Password	0000 to 9999	0300
TDES	Minutes: Seconds	Time Delay Engine Start	0 to 120 seconds	0:03
TDNE	Minutes: Seconds	Time Delay Normal to Emergency	0 to 1800 seconds	0:00
TDEN	Minutes: Seconds	Time Delay Emergency to Normal	0 to 1800 seconds	5:00
TDEC	Minutes: Seconds	Time Delay Engine Cool-off	0 to 1800 seconds	5:00
NOM FREQ	Hertz	Nominal Frequency	50 or 60 Hz	As ordered
NOM VOLTS	Volts	Nominal Voltage	120 to 600 volts	As ordered
S1 UV DROP	Volts	Source 1 Undervoltage Dropout Range: Breaker/Switch Style ATS Contactor Style ATS (2-position/3-position)	50 to 97% of Nominal System Voltage 78 to 97% of Nominal System Voltage	80% 85%
S2 UV DROP	Volts	Source 2 Undervoltage Dropout Range: Breaker/Switch Style ATS Contactor Style ATS (2-position/3-position)	50 to 97% of Nominal System Voltage 78 to 97% of Nominal System Voltage	80% 85%
S1 UV PICK	Volts	Source 1 Undervoltage Pickup Range: Breaker/Switch Style ATS Contactor Style ATS (2-position/3-position)	(Dropout + 2%) to 99% of Nominal System Voltage (Dropout + 2%) to 99% of Nominal System Voltage	90% 90%
S2 UV PICK	Volts	Source 2 Undervoltage Pickup Range: Breaker/Switch Style ATS Contactor Style ATS (2-position/3-position)	(Dropout + 2%) to 99% of Nominal System Voltage (Dropout + 2%) to 99% of Nominal System Voltage	90% 90%
S1 OV DROP	Volts	Source 1 Overvoltage Dropout Range: Breaker/Switch Style ATS Contactor Style ATS (2-position/3-position)	105 to 120% of Nominal System Voltage 105 to 110% of Nominal System Voltage	115% 110%
S2 OV DROP	Volts	Source 2 Overvoltage Dropout Range: Breaker/Switch Style ATS Contactor Style ATS (2-position/3-position)	105 to 120% of Nominal System Voltage 105 to 110% of Nominal System Voltage	115% 110%
S1 OV PICK	Volts	Source 1 Overvoltage Pickup Range: Breaker/Switch Style ATS Contactor Style ATS (2-position/3-position)	103% to (Dropout -2%) of Nominal System Voltage 103% to (Dropout -2%) of Nominal System Voltage	110% 105%
S2 OV PICK	Volts	Source 2 Overvoltage Pickup Range: Breaker/Switch Style ATS Contactor Style ATS (2-position/3-position)	103% to (Dropout -2%) of Nominal System Voltage 103% to (Dropout -2%) of Nominal System Voltage	110% 105%
S1 UF DROP	Hertz	Source 1 Underfrequency Dropout Range: Breaker/Switch Style ATS Contactor Style ATS (2-position/3-position)	90 to 97% of Nominal System Frequency 90 to 97% of Nominal System Frequency	94% 90%
S2 UF DROP	Hertz	Source 2 Underfrequency Dropout Range: Breaker/Switch Style ATS Contactor Style ATS (2-position/3-position)	90 to 97% of Nominal System Frequency 90 to 97% of Nominal System Frequency	94% 90%
S1 UF PICK	Hertz	Source 1 Underfrequency Pickup Range: Breaker/Switch Style ATS Contactor Style ATS (2-position/3-position)	(Dropout + 1 Hz) to 99% of Nominal System Frequency (Dropout + 1 Hz) to 99% of Nominal System Frequency	96% 95%
S2 UF PICK	Hertz	Source 2 Underfrequency Pickup Range: Breaker/Switch Style ATS Contactor Style ATS (2-position/3-position)	(Dropout + 1 Hz) to 99% of Nominal System Frequency (Dropout + 1 Hz) to 99% of Nominal System Frequency	96% 95%
S1 OF DROP	Hertz	Source 1 Overfrequency Dropout Range: Breaker/Switch Style ATS Contactor Style ATS (2-position/3-position)	103 to 110% of Nominal System Frequency 103 to 105% of Nominal System Frequency	106% 105%
S2 OF DROP	Hertz	Source 2 Overfrequency Dropout Range: Breaker/Switch Style ATS Contactor Style ATS (2-position/3-position)	103 to 110% of Nominal System Frequency 103 to 105% of Nominal System Frequency	106% 105%
S1 OF PICK	Hertz	Source 1 Overfrequency Pickup Range: Breaker/Switch Style ATS Contactor Style ATS (2-position/3-position)	101% to (Dropout -1 Hz) of Nominal System Frequency 101% to (Dropout -1 Hz) of Nominal System Frequency	104% 102%
S2 OF PICK	Hertz	Source 2 Overfrequency Pickup Range: Breaker/Switch Style ATS Contactor Style ATS (2-position/3-position)	101% to (Dropout -1 Hz) of Nominal System Frequency 101% to (Dropout -1 Hz) of Nominal System Frequency	104% 102%
TDN	Minutes: Seconds	Time Delay Neutral	0 to 120 seconds	0:00
BAUD RATE		Modbus Baud Rate	9600 or 19200	9600
ADDRESS		Modbus Address	1 to 247	1
PLANT EXER	Days	Plant Exerciser Programming	OFF, DAILY, 7-DAY, 14-DAY or 28 DAY	OFF
PE LOAD XFR		Plant Exerciser Load Transfer	0 or 1 (1 = yes)	0

**ATC-300+ Automatic Transfer Switch Controller**
**Table 2 Programmable Features and Setpoints (Cont.)**

SETPOINT	SETPOINT UNITS	DESCRIPTION	RANGE	FACTORY DEFAULT
PE DAY	Days	Plant Exerciser Day of the Week	1 SUN, 2 MON, 3 TUE, 4 WED, 5 THU, 6 FRI or 7 SAT	
PE HOUR	Hours	Plant Exerciser Hour	0 to 23	0
PE MINUTE	Minutes	Plant Exerciser Minute	0 to 59	0
TEST MODE		Test Mode	0, 1 or 2 (0 = No Load Engine Test, 1 = Load Engine Test, 2 = Disabled)	0
TER	Hours: Minutes	Engine run test time	0 min to 600 min	5:00
TPRE	Minutes: Seconds	Pretransfer delay timer	0 sec to 120 sec	0:00
PHASES		Three phase or single phase	1 or 3	AS ORDERED
VOLT UNBAL	Volts	Voltage Unbalanced	0 or 1 (1 = Enabled)	1
UNBAL DROP %	Percent	Percent for Unbalanced Voltage Dropout	5 to 20% of Phase to Phase Voltage Unbalance	20%
UNBAL PICK %	Percent	Percent for Unbalanced Voltage Pickup	Dropout minus (UNBAL DROP % -2) to 3%	10%
UNBAL DELAY	Seconds	Unbalanced Delay Timer	10 to 30	0:20
TDEF	Seconds	Time Delay Emergency Fail Timer	0 sec to 6 sec	6
IN-PHASE	Hertz	In-Phase Transition	0 or 1 (1 = Enabled)	1
IP FREQ DIFF	Hertz	In-phase Transition Frequency Difference	0.0 Hz to 3.0 Hz	1.0
SYNC TIME	Minutes	In-phase Transition Synchronization Timer	1 min to 60 min	5
PHASE REV		Phase Reversal	OFF, ABC, or CBA	OFF
DST ADJUST		Day Light Savings	0 or 1 (1 = Enabled)	1
MAN RETRAN		Manual Retransfer	0 or 1 (1 = Enabled)	0
LANGUAGE		Selected Language	English, French, or Spanish	English
CHANGE TIME/DATE?		Set Time and Date		
	Hours	Set Hour	0 to 23	Eastern Standard Time
	MINUTES	Set Minute	0 to 59	Eastern Standard Time
	WEEKDAY	Set Weekday	SUN, MON, TUE, WED, THU, FRI or SAT	Eastern Standard Time
	MONTH	Set Month	JAN or 01	Eastern Standard Time
	DAY	Set Day	1 to 31	Eastern Standard Time
	YEAR	Set Year	Current Year	Eastern Standard Time
RESET SYSTEM COUNTERS?			Yes or No	No
RESET ALL?		Resets all System Counters	Yes or No	No
RESET ENGINE RUN?	Hours	Resets ENGINE RUN Counter	0 to 9999	XXXX
RESET S1 CONN	Hours	Resets S1 CONN Counter	0 to 9999	XXXX
RESET S2 CONN	Hours	Resets S2 CONN Counter	0 to 9999	XXXX
RESET S1 AVAIL	Hours	Resets S1 AVAIL Counter	0 to 9999	XXXX
RESET S2 AVAIL	Hours	Resets S2 AVAIL Counter	0 to 9999	XXXX
RESET LOAD ENERG	Hours	Resets LOAD ENERG Counter	0 to 9999	XXXX
RESET TRANSFERS	Cycles (Counts)	Resets TRANSFERS Counter	0 to 9999	XXXX
SAVE SETPOINTS?		Save Changed Setpoints	Yes or No	Yes

See tables in the appendix for Voltage and Frequency Pickup and Dropout settings.

## Section 7: Troubleshooting and Maintenance

### 7.1 Level of Repair

This manual is written with the assumption that only ATS troubleshooting will be performed. If the cause of malfunction is traced to an ATC-300+, the unit should be replaced with a new unit. The malfunctioning unit should then be returned to EATON Electrical for factory repairs.

### 7.2 ATC-300+ Controller Troubleshooting

The Troubleshooting Guide (Table 3) is intended for service personnel to identify whether a problem being observed is external or internal to the unit. For assistance with this determination, contact EATON Electrical. If a problem is identified to be internal, the unit should be returned to the factory for replacement.

#### NOTICE

**WHILE PERFORMING TESTING, IF AN UNDESIRE OR UNDOCUMENTED RESULT OCCURS, FIRST CONTACT THE LOCAL GENSET DEALER. IF THE RESULT IS NOT CORRECTED, CONTACT THE EATON POWER QUALITY TECHNICAL SUPPORT CENTER AT 1-800-354-2070.**

**Table 3. Troubleshooting Guide**

SYMPTOM	PROBABLE CAUSE	POSSIBLE SOLUTION(S)
All front panel indicator LED's are off.	Control power is deficient or absent.	Verify that control power is connected at J7 and that it is within specifications.
	ATC-300+ is malfunctioning.	Replace the unit.
"Unit Status" LED is not blinking.	Control power is deficient or absent.	Verify that control power is connected at J7 and that it is within specifications.
	ATC-300+ is malfunctioning.	Replace the unit.
One or more voltage phases read incorrectly.	Incorrect wiring.	Verify voltage with multimeter. Check wiring. Replace the unit.
	ATC-300+ is malfunctioning.	Verify ground connection at J-5, Pin 12
Front panel pushbuttons do not work.	Bad connection inside the ATC-300+.	Replace the unit.
Unit did not accept new setpoints via front panel.	Operator error.	Enter the correct Password and change the setpoints.
	No pushbuttons pressed for 2.5 minutes.	Avoid intervals of 2.5 minutes of inactivity with pushbuttons when changing setpoints.
Source 1 or Source 2 is not available when it should be.	Voltage and/or frequency are not within setpoint values.	Verify voltage and/or frequency with multimeter. Check the programmed setpoint values.
Unit displays "LOCK-OUT".	Circuit breaker tripped.	Check for a overload/short circuit condition
	Lockout circuit wiring problem.	Check lockout circuit wiring.
Unit displays "INHIBIT".	No contact closure at Emergency Inhibit Input	Check Emergency Inhibit Wiring at J8, Pins 7 and 8.
Unit displays "SOURCE 1 DEVICE".	Source 1 breaker/contacter did not open when it was commanded to open (within 6 seconds).	Check the Source 1 circuit breaker shunt trip (ST) wiring.
	Source 1 breaker/contacter did not close when it was commanded to close (within 6 seconds).	Check the Source 1 circuit breaker spring release (SR) wiring.
	Source 1 closed contacts did not open when Source 1 breaker opened (within 6 seconds).	Check the Source 1 closed control input wiring on J-4, Pins 1 and 2 and J-8, Pins 1 and 2.
	Source 1 closed contacts did not close when Source 1 breaker closed (within 6 seconds).	Check the Source 1 closed control input wiring on J-4, Pins 1 and 2 and J-8, Pins 1 and 2.
Unit displays "SOURCE 2 DEVICE".	Source 2 breaker/contacter did not open when it was commanded to open (within 6 seconds).	Check the Source 2 circuit breaker shunt trip (ST) wiring.
	Source 2 breaker/contacter did not close when it was commanded to close (within 6 seconds).	Check the Source 2 circuit breaker spring release (SR) wiring.
	Source 2 closed contacts did not open when Source 2 breaker opened (within 6 seconds).	Check the Source 2 closed control input wiring on J-4, Pins 3 and 4 and J-8, Pins 3 and 4.
	Source 2 closed contacts did not close when Source 2 breaker closed (within 6 seconds).	Check the Source 2 closed control input wiring on J-4, Pins 3 and 4 and J-8, Pins 3 and 4.

**Table 3. Troubleshooting Guide (Cont.)**

SYMPTOM	PROBABLE CAUSE	POSSIBLE SOLUTION(S)
Unit will not perform an Engine Test.	Engine Test pushbutton was not pressed.	Press the Engine Test pushbutton to initiate the test.
	Display is not displaying the Home screen before initiating the test.	Use the Step/Enter pushbutton to step to the Home screen. If a timer is timing down, wait until it is done.
	Engine Test setpoint is set to Disable (Value of "2").	Re-program the Engine Test setpoint.
	Number of generators setpoint is set to 0.	Re-program the number of generators setpoint.
	Generator became unavailable when connected to the load.	Increase the Time Delay Emergency Fail (TDEF) timer setpoint.
	Generator became unavailable before connecting to the load.	Check the generator for proper function.
Plant Exerciser failed to exercise.	Generator voltage and/or frequency did not become available within 90 seconds of engine starting.	Verify the voltage and/or frequency with a multimeter. Check the programmed setpoint values. Check the engine maintenance.
	Incorrect date or time setting.	Verify real time clock settings for the time and date.
	Incorrect setpoint programmed for the PE DAY, PE HOUR, and/or PE MINUTE.	Re-program the PE DAY, PE HOUR, and/or PE MINUTE setpoint.
	Generator voltage and/or frequency did not become available within 90 seconds of engine starting.	Verify the voltage and/or frequency with a multimeter. Check the programmed setpoint values. Check the engine maintenance.
	Generator became unavailable when connected to the load.	Increase the TDEF timer setpoint.
Engine fails to start after the TDES times out.	Generator became unavailable before connecting to the load.	Check the generator for proper function.
	Incorrect wiring.	Check the wiring between the Gen Start relay (J-5, Pins 13 and 14) and the engine.
	Gen Start relay contacts are not closed.	Replace the unit.
	Engine did not start.	Check the generator for proper function.

**7.3 ATC-300 + Replacement**

Follow these procedural steps to replace the ATC-300 +.

- Step 1: Turn off the control power at the main disconnect or isolation switch of the control power supply. If the switch is not located within view from the ATC-300 +, lock it out to guard against other personnel accidentally turning it on.
- Step 2: Verify that all "foreign" power sources wired to the ATC-300 + are de-energized. These foreign power sources may also be present on some of the terminal blocks.
- Step 3: Before disconnecting any wires from the unit, make sure they are individually identified to assure that reconnection can be correctly performed. Make a sketch to help with the task of terminal and wire identification.
- Step 4: Remove all wires and disconnect plug-type connectors.

- Step 6: Remove the unit from the door or panel. Lay the original mounting screws aside for later use.
- Step 7: Align the unit with the opening in the door or panel.
- Step 8: Using the original mounting hardware, secure the replacement unit to the door or panel.
- Step 9: Using the sketch mentioned in Step 3, replace each wire at the correct terminal and make sure each is secure. Make certain that each harness plug is securely seated.
- Step 10: Restore control power to the unit.

**7.4 Maintenance and Care**

The ATC-300 + is designed to be a self-contained and maintenance-free unit. The printed circuit boards are calibrated and conformally coated at the factory. They are intended for service by factory-trained personnel only.



**CAUTION**

**SUPPORT THE ATC-300 + FROM THE REAR WHEN THE SCREWS ARE LOOSENED OR REMOVED IN STEP 5. WITHOUT SUCH SUPPORT, THE UNIT COULD FALL OR THE PANEL COULD BE DAMAGED.**

- Step 5: Remove the four (4) mounting screws, located on the four corners, which hold the unit and trim plate against the door or panel. These are accessed from the front of the unit. Support the unit and remove the two center screws.

## Appendix A: Display Message for Status and Timers

### Display Message

TDEC	Countdown cool-off timing before the generator contacts are opened.
TDES	Countdown timing before the generator contacts are closed.
TDNE	Countdown timing before Source 1 is disconnected before transferring to Source 2. Timing begins when Source 2 is available.
TDN	Countdown timing with both sources disconnected from the load.
TDEN	Countdown timing before Source 2 is disconnected before transferring to Source 1. Timing begins when Source 1 becomes available.
TRANSFER	Waiting for the switch to make the transfer from the neutral position to the intended source.
ATS NOT IN AUTOMATIC	Control input for monitor mode is closed.
LOCK-OUT OVERCURRENT TRIP	A trip condition has been detected by either breaker, and the system is locked-out from further transfers.
MANUAL	Waiting for an input signal to complete the manual re-transfer
INHIBIT	Indicates that a transfer to the Emergency Source is inhibited because the Emergency inhibit input is activated.
ENGINE RUN	The engine run test timer is counting down before the test is completed. Pressing the Engine Test pushbutton will abort this timer and the test.
START TEST?	To initiate an engine test sequence, press the Engine Test pushbutton again, or press Increase and Decrease pushbuttons simultaneously to clear.
WAIT FOR S2	Waiting for the Source 2 source voltage and frequency to become available.
TD PRE-TRAN	Countdown timer while waiting for a pre-transfer acknowledge input.
SYNC TIME	Countdown timing in minutes while waiting for sources to synchronize during an in phase transition.
SOURCE 1 DEVICE	Indicates that the Source 1 device (i.e. circuit breaker, contactor) failed to open or close
SOURCE 2 DEVICE	Indicates that the Source 2 device (i.e. circuit breaker, contactor) failed to open or close.
TDEF	Countdown timing before declaring Source 2 unavailable (accounts for momentary generator fluctuations).
TD UNBAL	Countdown timer before declaring a source unavailable due to a voltage unbalance condition.
TEST ABORTED	Indicates that an engine test or plant exercise was aborted after three unsuccessful attempts. Source 2 did not remain available while TDNE was timing.
GO TO SOURCE 2	Indicates that the load is connected to Source 2 because the Go To Source 2 control input is in the "unconnected" state.
FAILSAFE	Indicates that the load was connected to Source 2 but Source 2 became unavailable so the load transferred back to Source 1.
SETPOINTS ERROR	Memory problem with the setpoints. Contact the factory.
OPTIONS ERROR	Memory problem with the factory options. Contact the factory.
PROGRAMMING SETPOINTS	Setpoints are being saved in memory.
WAITING FOR NEUTRAL	Waiting for the neutral position to be reached by the switch.
WAITING FOR S1 TO OPEN	Waiting for the Source 1 device (i.e. circuit breaker, contactor) to open.
WAITING FOR S2 TO OPEN	Waiting for the Source 2 device (i.e. circuit breaker, contactor) to open.
WAITING FOR S1 TO CLOSE	Waiting for the Source 1 device (i.e. circuit breaker, contactor) to close.
WAITING FOR S2 TO CLOSE	Waiting for the Source 2 device (i.e. circuit breaker, contactor) to close.

**Appendix B: Operational Flowcharts**

- Utility - Generator Transfer Switch
- Dual Utility Transfer Switch
- In-phase Transition Implementation

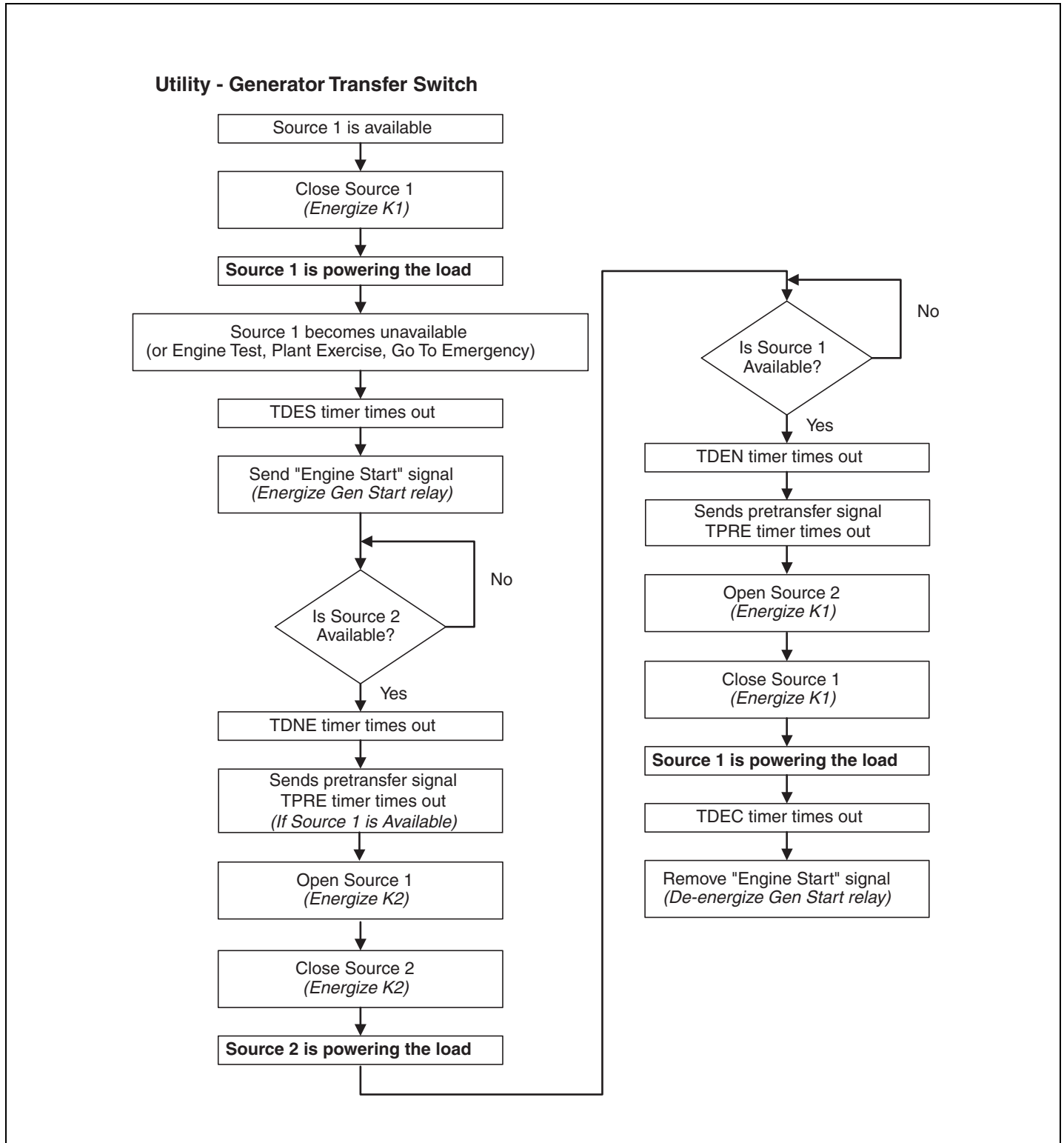

**Dual Utility Transfer Switch**

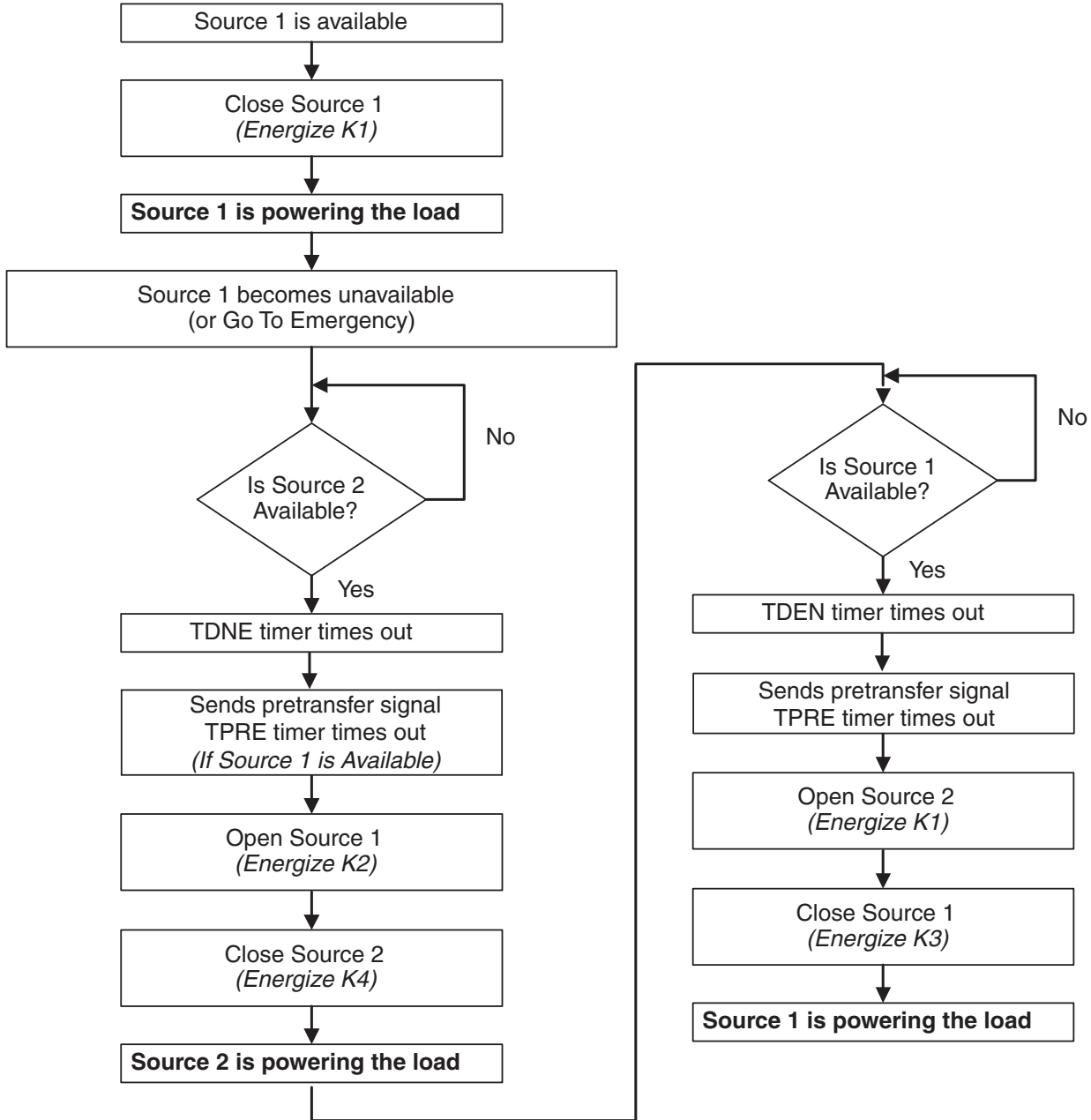

**In-Phase Transition Implementation**

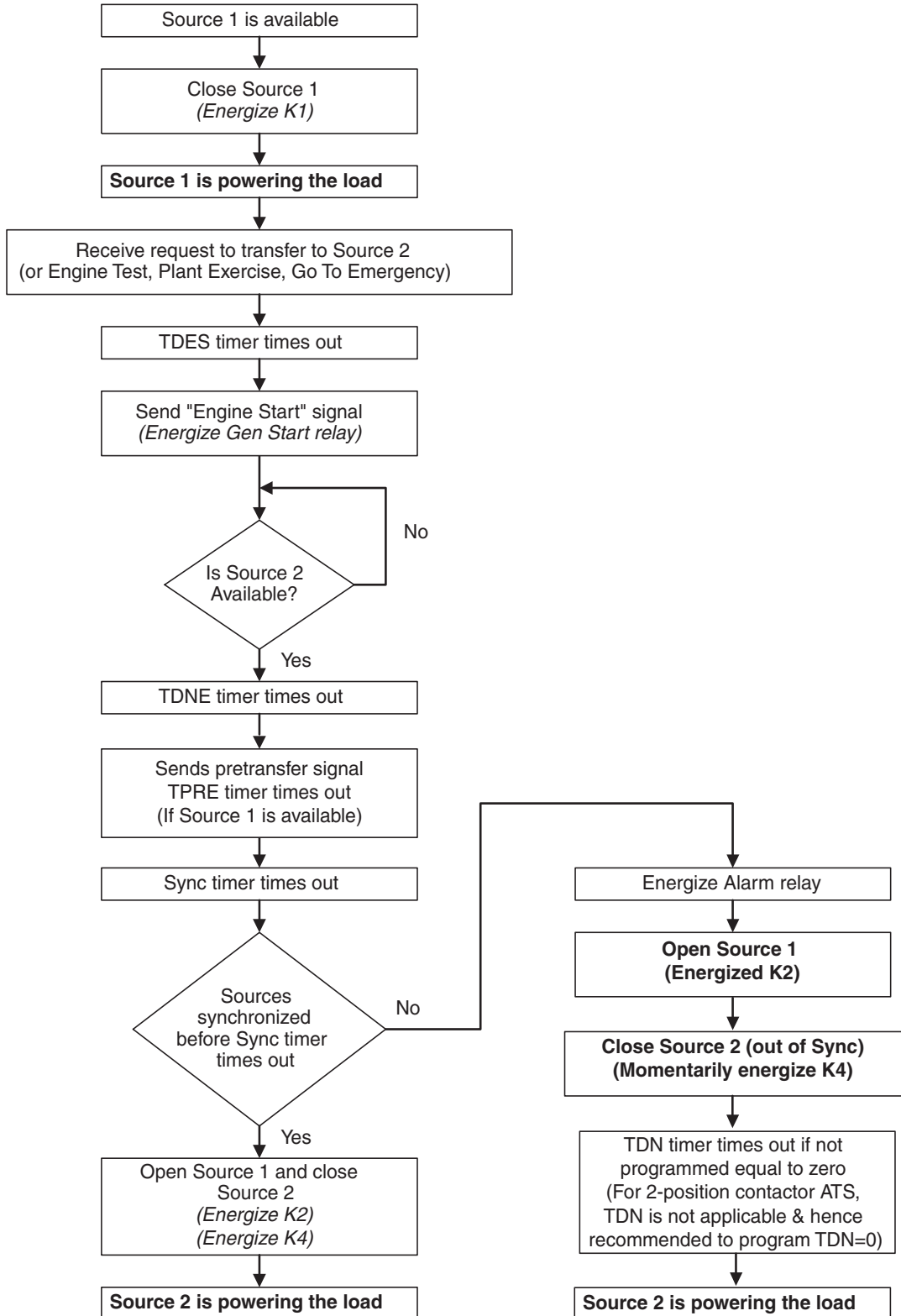

### Appendix C: Display Menu Tree

**Note:** Only standard and programmed optional Features will appear on the LCD Display. Optional Features that are not programmed will be skipped and will not appear on the LCD display.

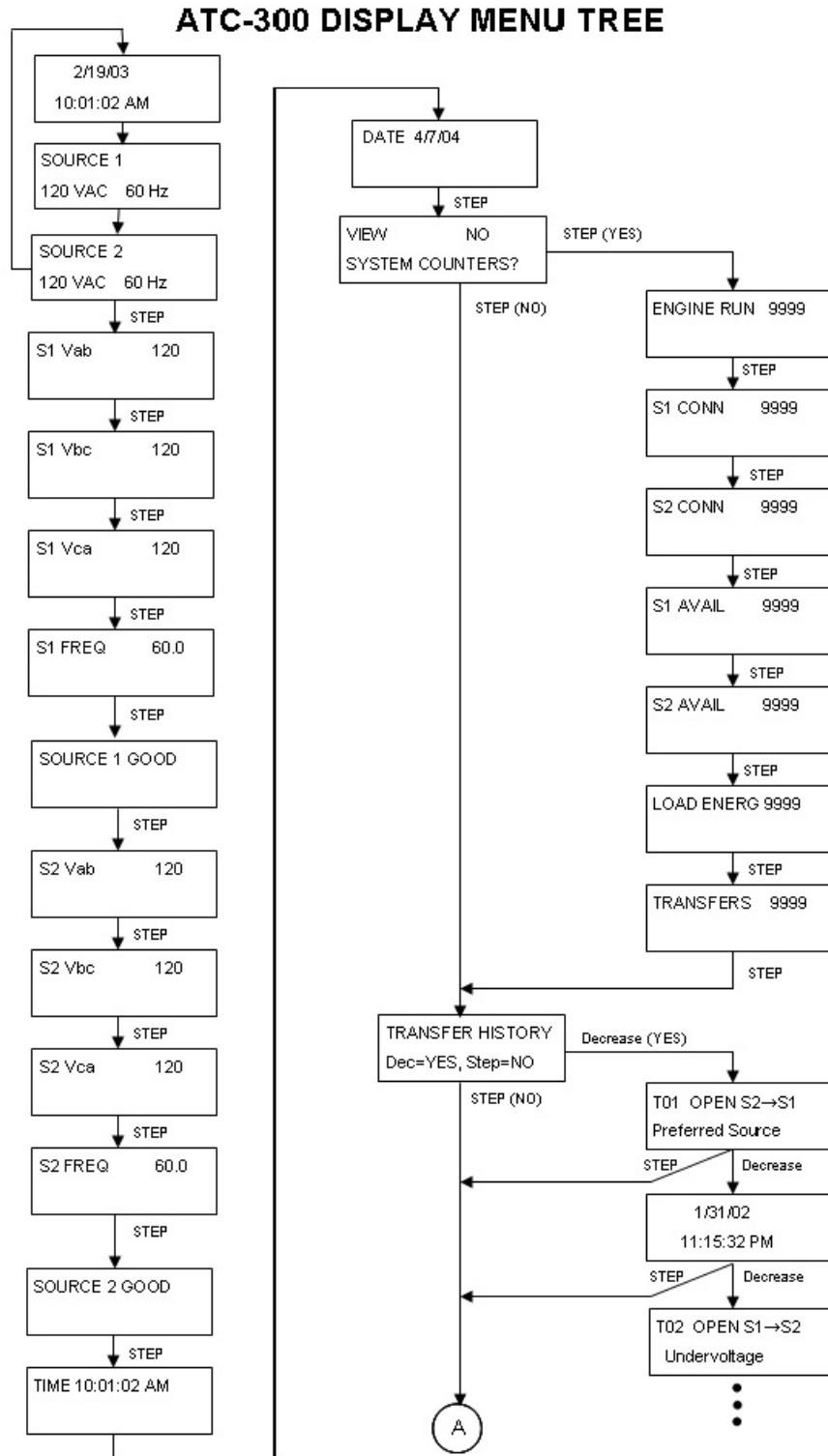

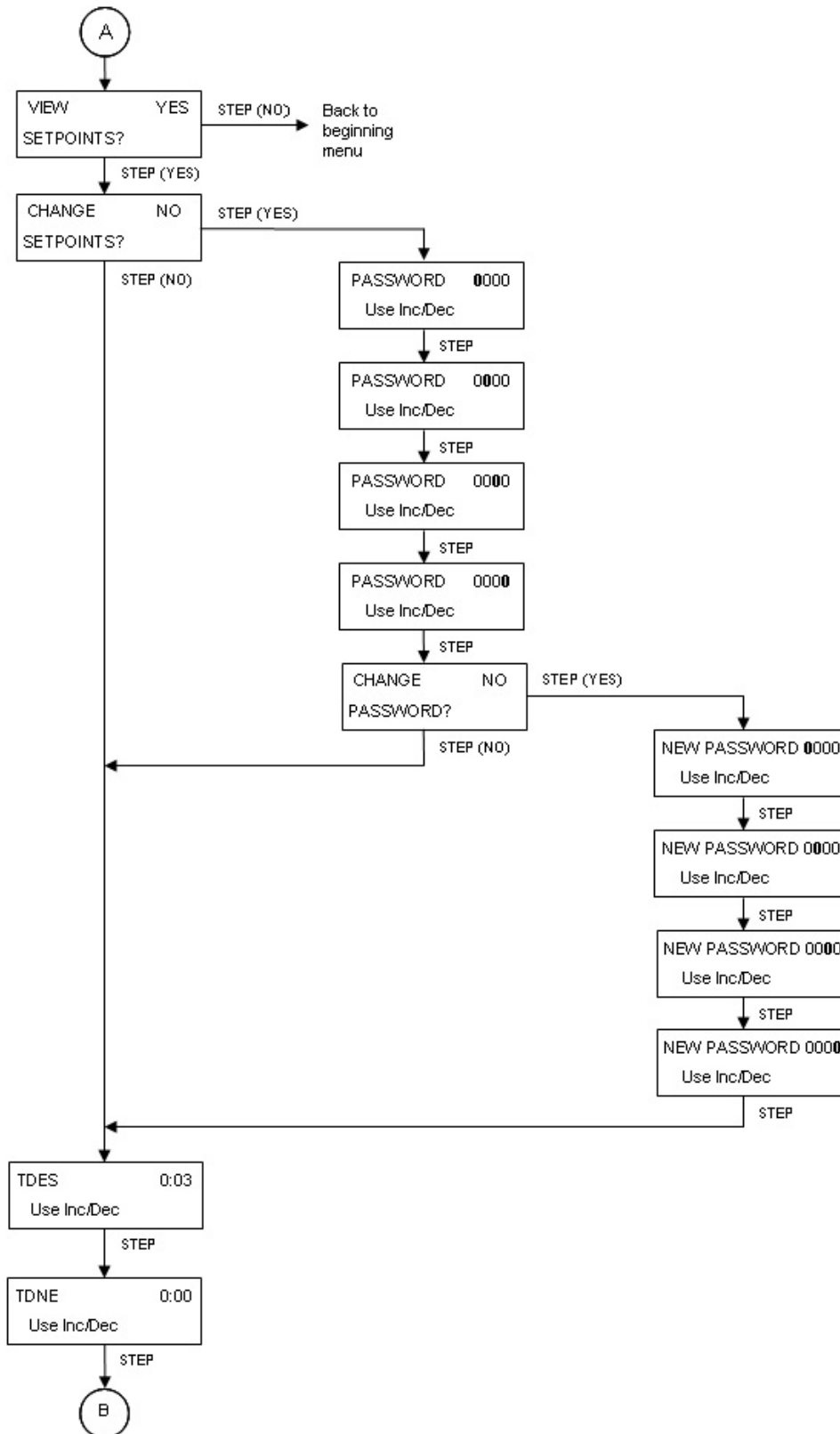

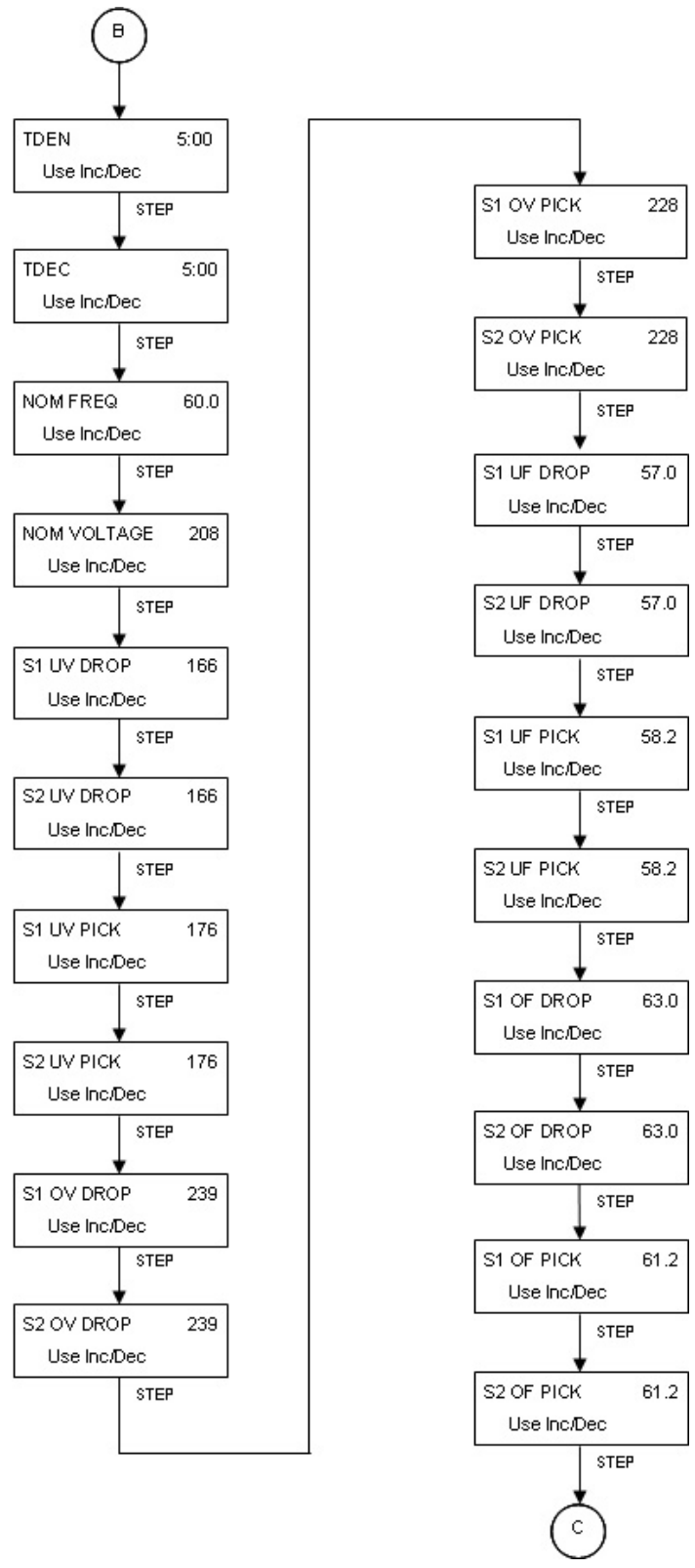

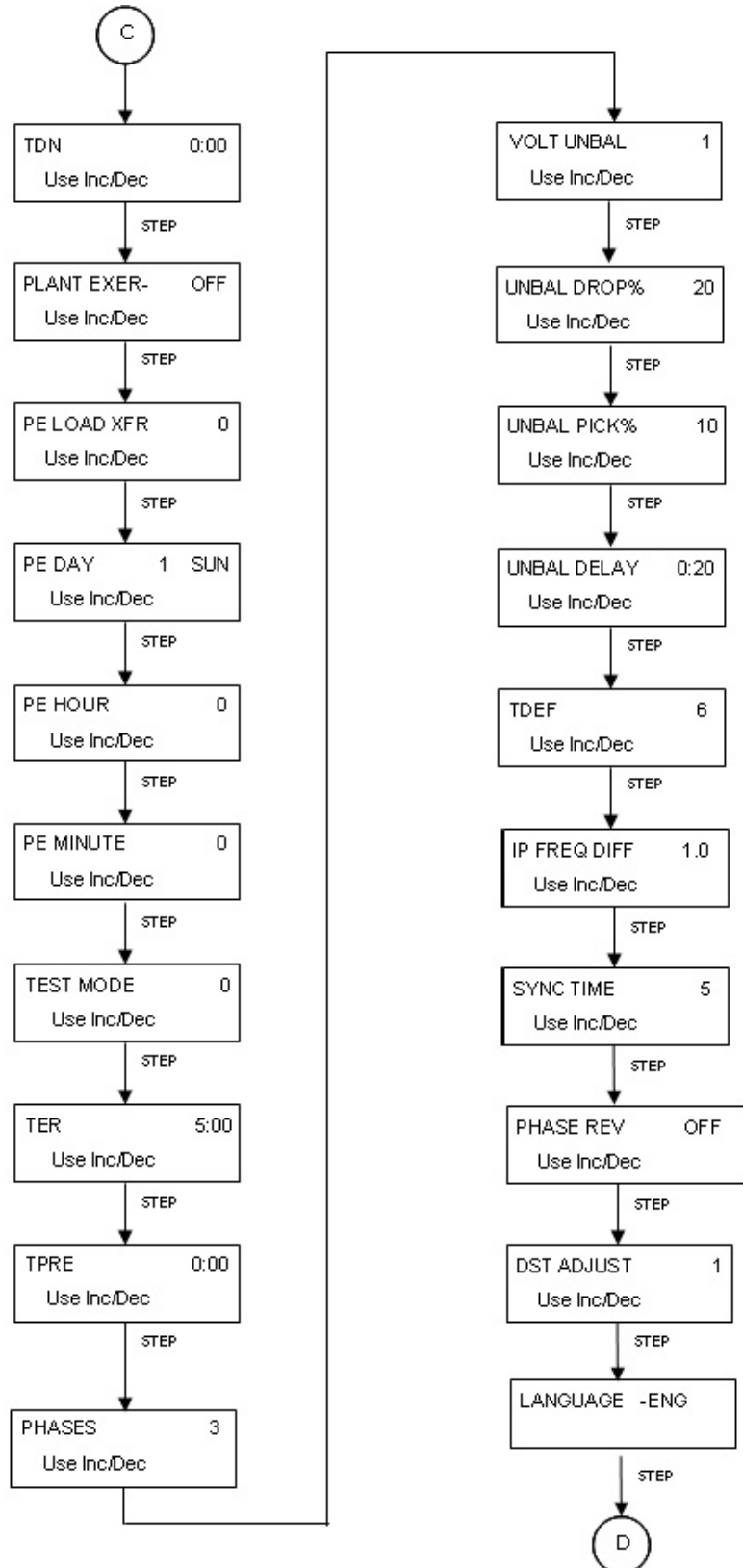

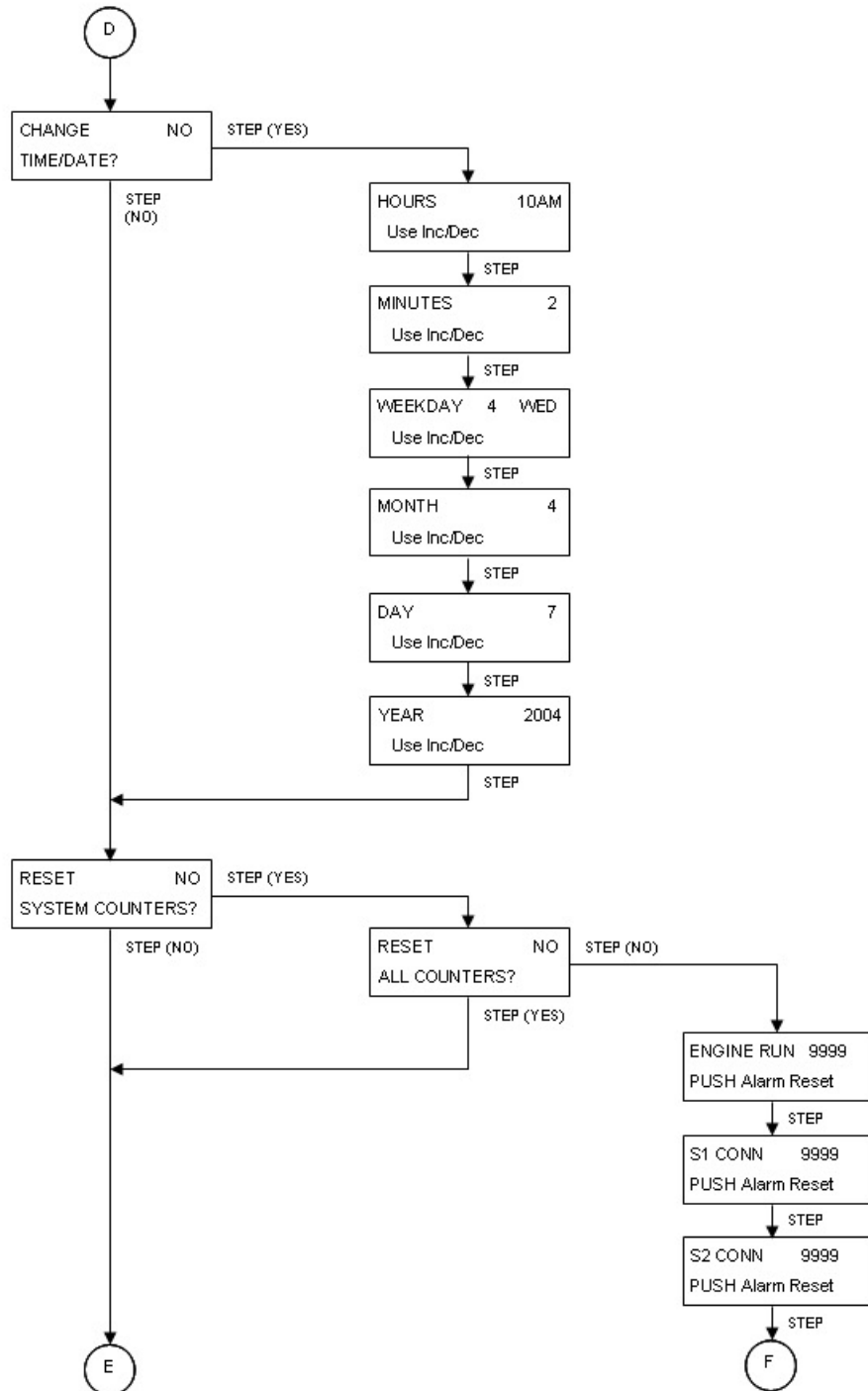

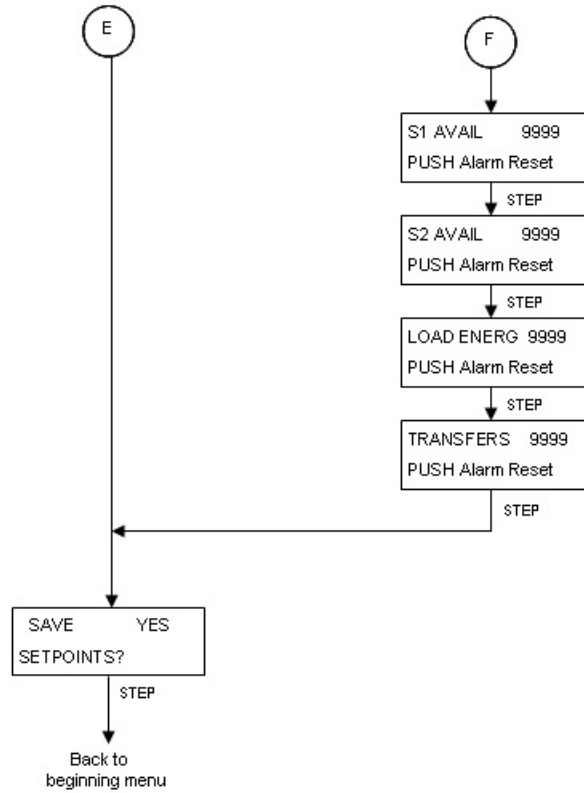

## Appendix D: Pickup / Dropout Tables

UNDERVOLTAGE PICKUP / DROPOUT TABLE

PERCENTAGE	VOLTAGE								
	120	208	220	240	380	415	480	600	
97	116	202	213	233	369	403	466	582	
96	115	200	211	230	365	398	461	576	
95	114	198	209	228	361	394	456	570	
94	113	196	207	226	357	390	451	564	
93	112	193	205	223	353	386	446	558	
92	110	191	202	221	350	382	442	552	
91	109	189	200	218	346	378	437	546	
<b>90</b>	<b>108</b>	<b>187</b>	<b>198</b>	<b>216</b>	<b>342</b>	<b>374</b>	<b>432</b>	<b>540</b>	Pickup-Breaker, Contactor (2-position/3-position)
89	107	185	196	214	338	369	427	534	
88	106	183	194	211	334	365	422	528	
87	104	181	191	209	331	361	418	522	
86	103	179	189	206	327	357	413	516	
<b>85</b>	<b>102</b>	<b>177</b>	<b>187</b>	<b>204</b>	<b>323</b>	<b>353</b>	<b>408</b>	<b>510</b>	Dropout- Contactor (2-position/3-position)
84	101	175	185	202	319	349	403	504	
83	100	173	183	199	315	344	398	498	
82	98	171	180	197	312	340	394	492	
81	97	168	178	194	308	336	389	486	
<b>80</b>	<b>96</b>	<b>166</b>	<b>176</b>	<b>192</b>	<b>304</b>	<b>332</b>	<b>384</b>	<b>480</b>	Dropout-Breaker
79	95	164	174	190	300	328	379	474	
78	94	162	172	187	296	324	374	468	
77	92	160	169	185	293	320	370	462	
76	91	158	167	182	289	315	365	456	
75	90	156	165	180	285	311	360	450	
74	89	154	163	178	281	307	355	444	
73	88	152	161	175	277	303	350	438	
72	86	150	158	173	274	299	346	432	
71	85	148	156	170	270	295	341	426	
70	84	146	154	168	266	291	336	420	
69	83	144	152	166	262	286	331	414	
68	82	141	150	163	258	282	326	408	
67	80	139	147	161	255	278	322	402	
66	79	137	145	158	251	274	317	396	
65	78	135	143	156	247	270	312	390	
64	77	133	141	154	243	266	307	384	
63	76	131	139	151	239	261	302	378	
62	74	129	136	149	236	257	298	372	
61	73	127	134	146	232	253	293	366	
60	72	125	132	144	228	249	288	360	
59	71	123	130	142	224	245	283	354	
58	70	121	128	139	220	241	278	348	
57	68	119	125	137	217	237	274	342	
56	67	116	123	134	213	232	269	336	
55	66	114	121	132	209	228	264	330	
54	65	112	119	130	205	224	259	324	
53	64	110	117	127	201	220	254	318	
52	62	108	114	125	198	216	250	312	
51	61	106	112	122	194	212	245	306	
50	60	104	110	120	190	208	240	300	

**OVERVOLTAGE PICKUP / DROPOUT TABLE**

PERCENTAGE	VOLTAGE								
	120	208	220	240	380	415	480	600	
120	144	250	264	288	456	498	576	720	
119	143	248	262	286	452	494	571	714	
118	142	245	260	283	448	490	566	708	
117	140	243	257	281	445	486	562	702	
116	139	241	255	278	441	481	557	696	
115	138	239	253	276	437	477	552	690	Dropout-Breaker
114	137	237	251	274	433	473	547	684	
113	136	235	249	271	429	469	542	678	
112	134	233	246	269	426	465	538	672	
111	133	231	244	266	422	461	533	666	
110	132	229	242	264	418	457	528	660	Pickup-Breaker Dropout-Contactor (2-position/3-position)
109	131	227	240	262	414	452	523	654	
108	130	225	238	259	410	448	518	648	
107	128	223	235	257	407	444	514	642	
106	127	220	233	254	403	440	509	636	
105	126	218	231	252	399	436	504	630	Pickup-Contactor (2-position/3-position)

**UNDERFREQUENCY PICKUP / DROPOUT TABLE**

PERCENTAGE	FREQUENCY		
	50	60	
97	49	58	
96	48	58	Pickup-Breaker
95	48	57	Pickup-Contactor (2-position/3-position)
94	47	56	Dropout-Breaker
93	47	56	
92	46	55	
91	46	55	
90	45	54	Dropout-Contactor (2-position/3-position)

**OVERFREQUENCY PICKUP / DROPOUT TABLE**

PERCENTAGE	FREQUENCY		
	50	60	
110	55	66	
109	55	65	
108	54	65	
107	54	64	
106	53	64	Dropout-Breaker
105	53	63	Dropout-Contactor (2-position/3-position)
104	52	62	Pickup-Breaker
103	52	62	
102	51	61	Pickup-Contactor (2-position/3-position)

**NOTES:**



**ATC-300+ Automatic  
Transfer Switch Controller**

NOTES:

This instruction booklet is published solely for information purposes and should not be considered all-inclusive. If further information is required, you should consult EATON.

Sale of product shown in this literature is subject to terms and conditions outlined in appropriate EATON selling policies or other contractual agreement between the parties. This literature is not intended to and does not enlarge or add to any such contract. The sole source governing the rights and remedies of any purchaser of this equipment is the contract between the purchaser and EATON.

NO WARRANTIES, EXPRESSED OR IMPLIED, INCLUDING WARRANTIES OF FITNESS FOR A PARTICULAR PURPOSE OR MERCHANTABILITY, OR WARRANTIES ARISING FROM COURSE OF DEALING OR USAGE OF TRADE, ARE MADE REGARDING THE INFORMATION, RECOMMENDATIONS AND DESCRIPTIONS CONTAINED HEREIN. In no event will EATON be responsible to the purchaser or user in contract, in tort (including negligence), strict liability or otherwise for any special, indirect, incidental or consequential damage or loss whatsoever, including but not limited to damage or loss of use of equipment, plant or power system, cost of capital, loss of power, additional expenses in the use of existing power facilities, or claims against the purchaser or user by its customers resulting from the use of the information, recommendations and description contained herein.

CSA is a registered trademark of the Canadian Standards Association. National Electrical Code and NEC are registered trademarks of the National Fire Protection Association, Quincy, Mass. NEMA is the registered trademark and service mark of the National Electrical Manufacturers Association. Uniform Building Code (UBC) is a trademark of the International Conference of Building Officials (ICBO). UL is a federally registered trademark of Underwriters Laboratories Inc.

Eaton Corporation  
Electrical Group  
1000 Cherrington Parkway  
Moon Township, PA 15108  
United States  
877-ETN CARE (877-386-2273)  
Eaton.com