

AGSWITCH 30-800 AMPERES



PRODUCT DESCRIPTION

An economical line of transfer switches with micro-processor based logic, offering a standard feature package, for agricultural standby power applications on 30-800 ampere systems at 208 and 240 volts.

STANDARD FEATURES

- UL 1008 Listed
- Microprocessor Based Logic
- Vertical In-Line Mechanism
- Normal/Standby Source Monitoring
- Group 9 (see below for description)
- Plant Exerciser with Fail Safe (Programmable)
- High Withstand, Closing, and Interrupting Ratings
- Manual Transfer Under Load
- Engine Start Contacts
- NEMA 3R, Gasketed Enclosure
- Go To Emergency Contact (Area Protection)
- Time Delay Neutral

FEATURE GROUP 9

- Time Delay Normal to Emergency
- Time Delay Engine Start
- Time Delay Emergency to Normal
- Time Delay Engine Cooldown
- Emergency Source Sensing
- Pilot Light – Normal
- Pilot Light – Emergency
- Auxiliary Contacts (4NO/4NC) – Normal
- Auxiliary Contacts (4NO/4NC) – Emergency

OPTIONAL FEATURES

- Feature 37A * Service Entrance without Ground Fault
- Feature 16N ** Overcurrent Trips (LI) on Normal
- Feature 16B ** Overcurrent Trips (LI) on Normal and Emergency

* Requires either 16N or 16B. Not available on 30-150A.

** Only available with 37A

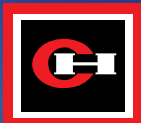

Cutler-Hammer

EATON

AGSWITCH

30-800 AMPERES



Interior of ATVAKDA30225BRU

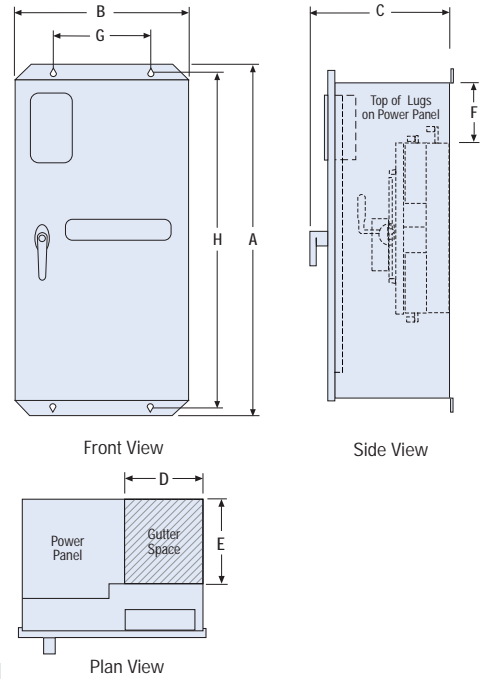

Switch Type	Power Panel			Enclosure			Gutter Space			Bolt Pattern		
	H	W	D	H	W	D	W	D	Bending	Horiz.	Vert.	
	(In.)	(In.)	(In.) ❶	(In.)	(In.)	(In.) ❷	(In.)	(In.)	(In.)	(In.)	(In.)	
	A	B	C	D	E	F	G	H				
FD (30-150A)	11.00	17.00	6.81	44	21	18.13	21	14.5	4	11.00	42.86	
KD (225A)	24.50	11.88	17.5	44	21	19.63	8	14.5	6	11.00	42.86	
KD (300A)	24.50	11.88	17.5	52	21	19.63	8	14.5	9	11.00	50.86	
LD (400A)	26.00	16.88	17.5	61	26	19.63	8	14.5	11	16.00	59.86	
MA (600A)	36.25	16.88	17.5	73	26	20.63	8	14.5	12	16.00	71.86	
NB (800A)	36.25	16.88	19.0	79	26	20.63	8	14.5	15	16.00	77.86	

Amperes	Approx. Shipping Weight (lbs.)
30-150	170
225-300	340
400	390
600	485
800	570

- ❶ Depth includes the interior handle extended.
- ❷ Enclosure depth includes the exterior door handle.
- ❸ 30-150 Amperes Only.
- ❹ Single Phase Only.

For example, to order the following:
AGswitch Automatic Transfer Switch, 208 Volts, 60 Hz, 3 phase, 4 wire, 3 pole, 225 amperes, NEMA 3R Gasketed Enclosure, UL Listed, Integral Overcurrent Protection Both Sources, Service Entrance Rated with optional features 16B and 37A
The ordering catalog sequence would be:
ATVAKDB30225BRU

CATALOG NUMBERS

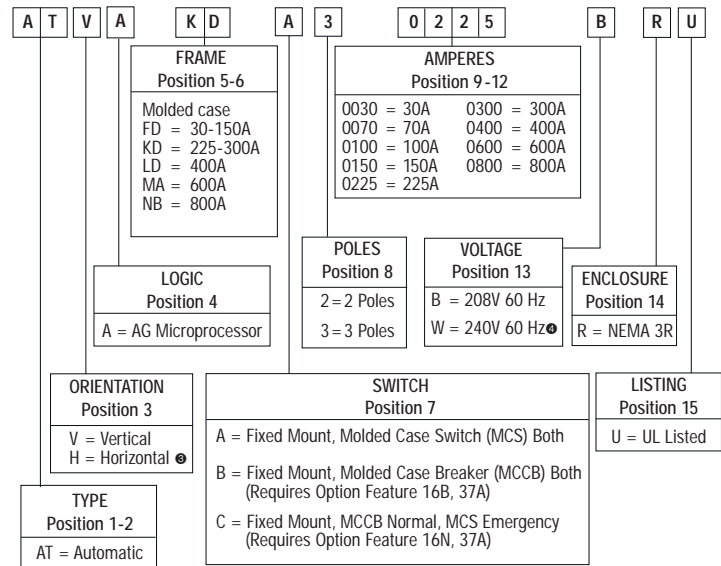

For more information on Cutler-Hammer products and services, call 1-800-525-2000 or 1-616-982-1059, For engineering services call 1-800-498-2678, or visit our web site at www.cutlerhammer.com

Cutler-Hammer
Pittsburgh, Pennsylvania U.S.A.

Publication No. PA.15A.01.S.E
November 1998
Printed in U.S.A. / DLD2624

Copyright Cutler-Hammer Inc., 1998
All Rights Reserved.



PA15A01SE