



## O & M Manual for the EATON ATC-300 Controlled Transfer Switch

Instruction Booklet

### New Information

<i>Description</i>	<i>Page</i>
Introduction . . . . .	2
Receiving, Handling, and Storage . . . . .	6
Equipment Description . . . . .	7
Installation and Wiring . . . . .	19
Operation . . . . .	28
Testing and Problem Solving . . . . .	31
Adjustments . . . . .	32
Maintenance . . . . .	33
Renewal Parts Guide . . . . .	34
ATC-300 Controlled ATS Quick Start Instructions . . . . .	36
Appendix A: Pickup / Dropout Tables . . . . .	48



**! WARNING**

**READ AND UNDERSTAND THE INSTRUCTIONS CONTAINED HEREINAFTER BEFORE ATTEMPTING TO UNPACK, ASSEMBLE, OPERATE, OR MAINTAIN THIS EQUIPMENT.**

**HAZARDOUS VOLTAGES ARE PRESENT INSIDE TRANSFER SWITCH ENCLOSURES THAT CAN CAUSE DEATH OR SEVERE PERSONAL INJURY. FOLLOW PROPER INSTALLATION, OPERATION, AND MAINTENANCE PROCEDURES TO AVOID THESE VOLTAGES.**

**TRANSFER SWITCH EQUIPMENT COVERED BY THIS INSTRUCTION BOOK IS DESIGNED AND TESTED TO OPERATE WITHIN ITS NAMEPLATE RATINGS. OPERATION OUTSIDE OF THESE RATINGS MAY CAUSE THE EQUIPMENT TO FAIL RESULTING IN DEATH, SERIOUS BODILY INJURY, AND/OR PROPERTY DAMAGE. ALL RESPONSIBLE PERSONNEL SHOULD LOCATE THE DOOR MOUNTED EQUIPMENT NAMEPLATE AND BE FAMILIAR WITH THE INFORMATION PROVIDED ON THE NAMEPLATE. A TYPICAL EQUIPMENT NAMEPLATE IS SHOWN IN FIGURE 1.**

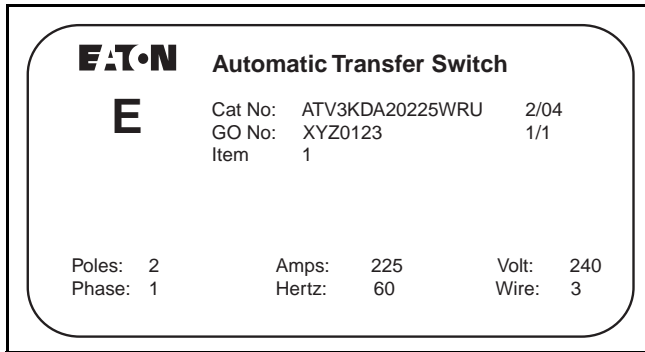

**Figure 1. Typical Automatic Transfer Switch (ATS) Equipment Nameplate.**

All possible contingencies that may arise during installation, operation, or maintenance, and all details and variations of this equipment do no purport to be covered by these instructions. If further information is desired by the purchaser regarding a particular installation, operation, or maintenance of particular equipment, please contact an authorized Eaton Sales Representative or the installing contractor.

**SECTION 1: INTRODUCTION**

**1.1 Preliminary Comments and Safety Precautions**

This technical document is intended to cover most aspects associated with the installation, application, operation, and maintenance of the Automatic Transfer Controller (ATC-300) Controlled ATS with ratings from 30 through 1000 (1200 non-UL) amperes (A). It is provided as a guide for authorized and qualified personnel only. Please refer to the specific WARNING and CAUTION in Section 1.1.2 before proceeding. If further information is required by the purchaser regarding a particular installation, application, or maintenance activity, please contact an authorized Eaton sales representative or the installing contractor.

**1.1.1 Warranty and Liability Information**

No warranties, expressed or implied, including warranties of fitness for a particular purpose of merchantability, or warranties arising from course of dealing or usage of trade, are made regarding the information, recommendations and descriptions contained herein. In no event will Eaton be responsible to the purchaser or user in contract, in tort (including negligence), strict liability or otherwise for any special, indirect, incidental or consequential damage or loss whatsoever, including but not limited to damage or loss of use of equipment, plant or power system, cost of capital, loss of power, additional expenses in the use of existing power facilities, or claims against the purchaser or user by its customers resulting from the use of the information and descriptions contained herein.

**1.1.2 Safety Precautions**

All safety codes, safety standards, and/or regulations must be strictly observed in the installation, operation, and maintenance of this device.

**! WARNING**

**THE WARNINGS AND CAUTIONS INCLUDED AS PART OF THE PROCEDURAL STEPS IN THIS DOCUMENT ARE FOR PERSONNEL SAFETY AND PROTECTION OF EQUIPMENT FROM DAMAGE. AN EXAMPLE OF A TYPICAL WARNING LABEL HEADING IS SHOWN ABOVE TO FAMILIARIZE PERSONNEL WITH THE STYLE OF PRESENTATION. THIS WILL HELP TO INSURE THAT PERSONNEL ARE ALERT TO WARNINGS, WHICH APPEAR THROUGHOUT THE DOCUMENT. IN ADDITION, WARNINGS AND CAUTIONS ARE ALL UPPER CASE AND BOLDFACE.**

**! CAUTION**

**COMPLETELY READ AND UNDERSTAND THE MATERIAL PRESENTED IN THIS DOCUMENT BEFORE ATTEMPTING INSTALLATION, OPERATION, OR APPLICATION OF THE EQUIPMENT. IN ADDITION, ONLY QUALIFIED PERSONS SHOULD BE PERMITTED TO PERFORM ANY WORK ASSOCIATED WITH THIS EQUIPMENT. ANY WIRING INSTRUCTIONS PRESENTED IN THIS DOCUMENT MUST BE FOLLOWED PRECISELY. FAILURE TO DO SO COULD CAUSE PERMANENT EQUIPMENT DAMAGE.**

**1.2 General Information**

Transfer switches are used to protect critical electrical loads against loss of power. The load's Source 1 power source is

backed up by a Source 2 power source. A transfer switch is connected to both the Source 1 and Source 2 power sources and supplies the load with power from one of the two sources. In the event that power is lost from Source 1, the transfer switch transfers the load to the Source 2 power source. This transfer can be automatic or manual, depending upon the type of transfer switch equipment being used. Once Source 1 power is restored, the load is automatically or manually transferred back to the Source 1 power source, again depending upon the type of transfer equipment being used (Figure 2).

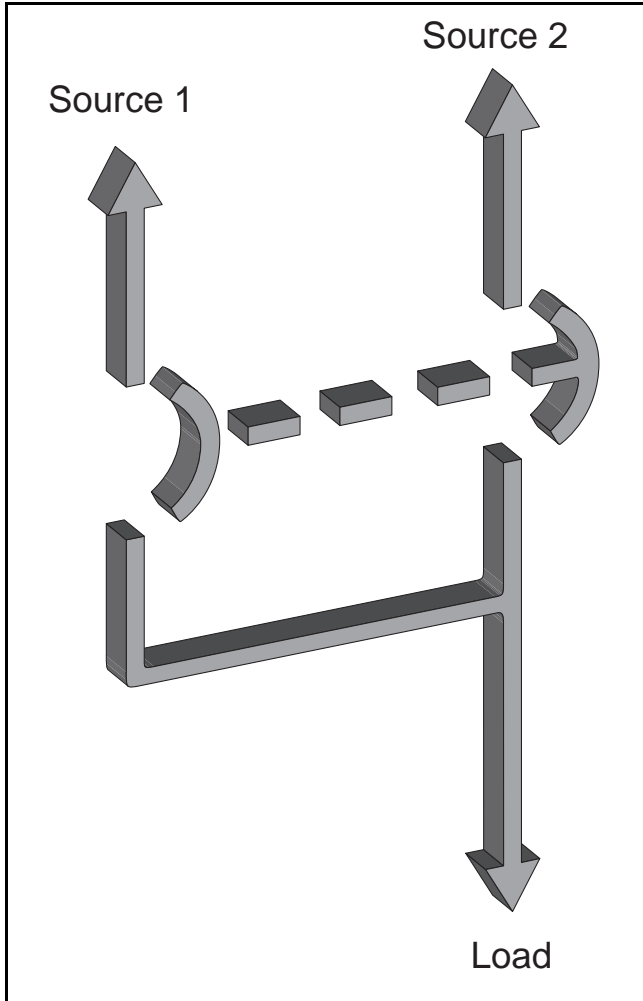

**Figure 2. Typical Load Transfer Switch (Circuit Breaker Type) Schematic.**

In ATS equipment, the switch’s intelligence system initiates the transfer when the Source 1 power fails, falls below, or rises above a preset voltage. If the Source 2 power source is a standby generator, the ATS initiates generator startup and transfers to the Source 2 power source when sufficient generator voltage is available. When Source 1 power is restored, the ATS automatically transfers back and initiates generator shutdown. In the event the Source 1 power source fails and the Source 2 power source does not appear, the ATS remains connected to the Source 1 power source until the Source 2 power source does appear. Conversely, if connected to the Source 2 power source and the Source 2 power source fails

while the Source 1 power source is still unavailable, the ATS remains connected to the Source 2 power source.

ATSs automatically perform the transfer function, and include three basic elements:

1. Main contacts to connect and disconnect the load to and from the power source.
2. A mechanism to transfer the main contacts from source to source.
3. Intelligence/supervisory circuits to constantly monitor the condition of the power sources and thus provide the intelligence necessary for the switch and related circuit operation.

**1.2.1 Design Configuration**

The Eaton ATS is a rugged, compact design that uses molded case switches and/or circuit breakers to transfer essential loads from one power source to another (Figures 3 [225-1200 A] and 4 [30-150 A]). Molded case switches are mechanically and electrically interlocked to prevent both switching devices from being closed at the same time.

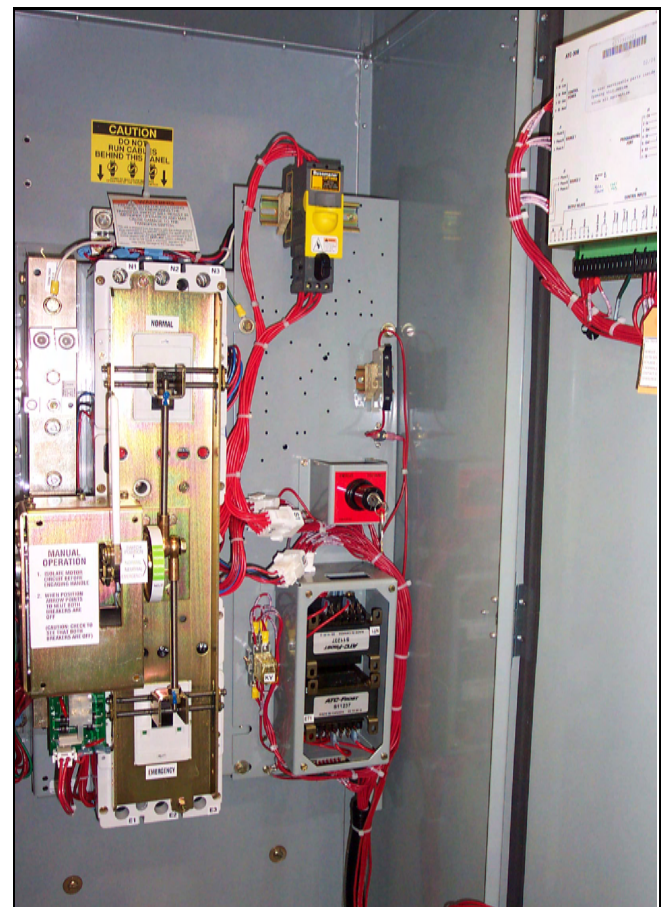

**Figure 3. Typical Power Panel for 225-1200 A Models (Deadfront Covers Removed).**

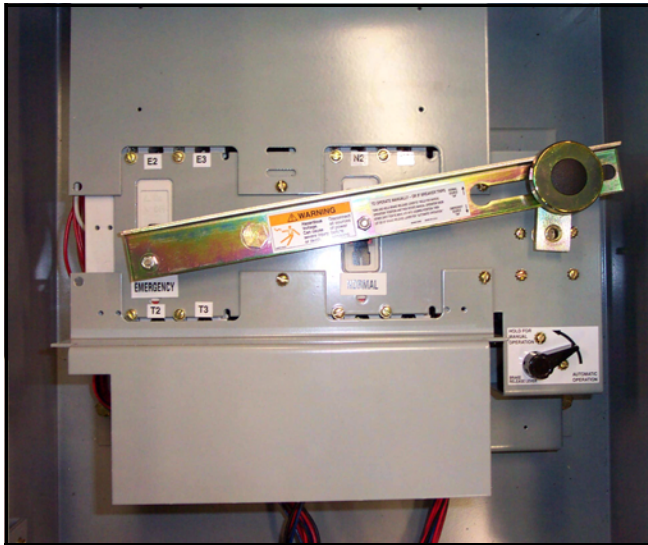

Figure 4. Typical Power Panel for 30-150 A Models (Deadfront Cover Installed).

Molded case switches and the associated transfer mechanisms are mounted vertically to save space in the assembly. The compact, vertical configuration uses a positive, metallic transfer and interlocking system between the molded case switches.

The Eaton ATS was designed with easy installation and simplified maintenance in mind. Three main panels comprise the transfer switch design:

1. Power panel;
2. Voltage selection and transformer panel (if required); and
3. Microprocessor-based logic panel.

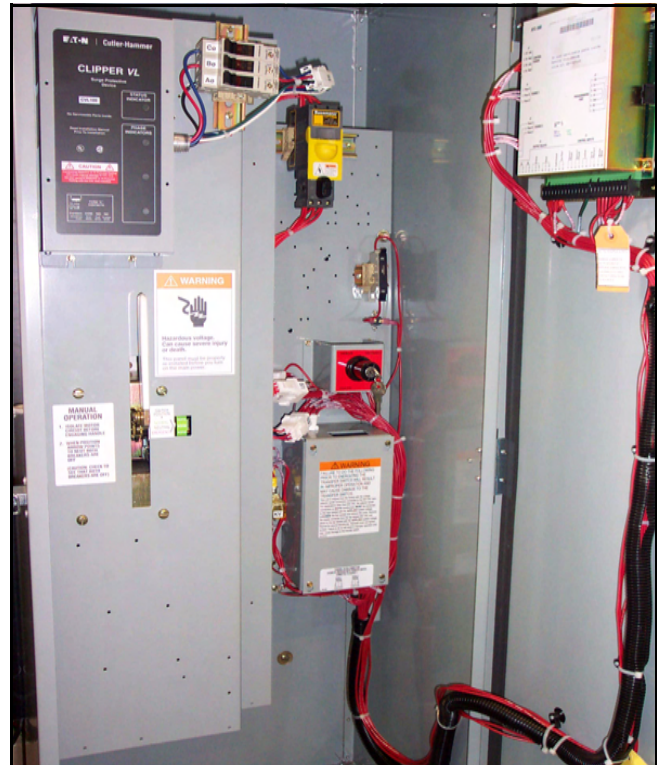

Figure 5. Vertical Design Transfer Switch with the Deadfront Cover in Place Over the Power Panel (225-1200 A).

Each panel is independently mounted with interconnecting wiring terminated at the connector receptacles on the ATC-300 Controller. Door or individual panel removal is achieved without disturbing critical connections by removing the connectors from the receptacles and cutting the wire ties that secure the wires to the door.

Mounting the enclosure is simple using top and bottom mounting flanges with elongated (teardrop) mounting holes. These mounting holes, along with power panel positioning bolts and pre-tapped inserts, insure proper power panel mounting after the initial enclosure installation or when switching from top to bottom or bottom to top entry. Refer to Section 4 for specific mounting and modification details.

### 1.3 ATS Catalog Number Identification

Transfer switch equipment catalog numbers provide a significant amount of relevant information that pertains to a particular piece of equipment. The Catalog Number Identification Table (Table 1) provides the required interpretation information. An example is offered here to initially simplify the process.

**Example:** Catalog Number (circled numbers correspond to position headings in Table 1.1):

① to ② ③ ④ ⑤ to ⑥ ⑦ ⑧ ⑨ to ⑫ ⑬ ⑭ ⑮  
 AT V 3 KD A 2 0225 W R U

The catalog number ATV3KDA20225WRU describes an ATS with the switching devices mounted vertically in the enclosure. The intelligence represented by the control panel is ATC-300 logic. The Eaton Series C Type HKD is used as the switching device and is in the form of a 2-pole molded case

switch on each source. The continuous current rating of this equipment is 225 A and applicable at 240 Vac, 60 Hz. The transfer switch equipment is enclosed in a NEMA 3R enclosure and is listed for UL applications.

**Table 1. Transfer Switch Catalog Number Explanation**

Positions 1 to 2		Position 3		Position 4		Positions 5 to 6		
Basic Device		Switching Device Orientation		Control Panel		Switching Device		
Automatic Transfer Switch	AT	Vertical	V <sup>1</sup>	ATC-300 Controller	3	HFD	Eaton Series C	FD
		Horizontal	H <sup>2</sup>			HKD	Eaton Series C	KD
						HLD	Eaton Series C	LD
						HMDL	Eaton	MD
						NB	Eaton	NB
						HND <sup>3</sup>	Eaton Series C	ND
				-				

Position 7		Position 8		Positions 9 to 12		Position 13		Position 14		Position 15	
Switching Device Arrangement		Number of Poles		Ampere Rating		Voltage/Frequency		Enclosure		Listing	
Fixed Mount Molded Case	A	Two	2	30 A – 0030		600 Vac/60 Hz	E	Type 12	J	*UL/CSA Listing	U
Switches Both Power Sources				70 A – 0070		480 Vac/60 Hz	X	Type 3R	R	No Listing	X
Fixed Mount Molded Case	B	Three	3	100 A – 0100		240 Vac/60 Hz	W	Open	K		
Circuit Breakers Both Power Sources				150 A – 0150		208 Vac/60 Hz	B				
Fixed Mount Molded Case	C	Four	4	225 A – 0225		120 Vac/60 Hz	A				
Circuit Breaker Source 1 Power Source,				300 A – 0300		220 Vac/50 or 60 Hz	G				
Molded Case Switch Source 2				400 A – 0400		600 Vac/50 Hz	K				
Power Source				600 A – 0600		415 Vac/50 Hz	O				
Fixed Mount Molded Case	D			800 A – 0800		401 Vac/50 Hz	N				
Switch Source 1 Power Source,				1000 A – 1000		380 Vac/50 Hz	H				
Molded Case Circuit Breaker				1200 A – 1200		365 Vac/50 Hz	Z				
Source 2 Power Source						230 Vac/50 Hz	M				

- Notes:** 1 Vertical orientation (225-1200 A)  
 2 Horizontal orientation (30-150 A)  
 3 Consult factory for availability.  
 \*CSA will only be applied to molded case switches, both power sources.

**1.4 Environmental Conditions**

**1.4.1 Seismic**

With proper installation, and by including the appropriate optional feature that includes specially designed cleats (optional feature #42), the ATs have a seismic capability which exceeds the worst case Zone 4 required levels, per both the Uniform Building Code and the California Building Code.

**1.4.2 Operational Conditions**

Normally, an ATS is applied indoors in an electrical equipment room. In the appropriate enclosure, it can be used for outdoor applications where the equipment is subject to falling rain, freezing temperatures, and no greater than 90% humidity (non-condensing). The ambient temperature range for operation is between -20 and 70°C (-4 to 158°F).

**1.5 Glossary**

With respect to their use within this document and as they relate to transfer switch and controller operation, the following terminology is defined.

**Available**

A source is defined as “available” when it is within its under-voltage/overvoltage/ underfrequency/overfrequency (if applicable) setpoint ranges for the nominal voltage and frequency setting.

**Connected**

Connected is defined as when the input is shorted by an external contact or connection.

**Failed or Fails**

A source is defined as “failed” when it is outside of the applicable voltage and frequency setpoint ranges for the nominal voltage and frequency setting for a time exceeding 0.5 seconds after the time delay emergency fail (TDEF) time delays expires.

**Failsafe**

Failsafe is a feature that prevents disconnection from the only available power source and also forces a transfer or re-transfer operation to the only available power source.

**Re-Transfer**

Re-transfer is defined as a change of the load connection from the Source 2 to the Source 1.

**Source 1**

Source 1 is the primary source (normal source, normal power source, or normal).

**Source 2**

Source 2 is the secondary source (emergency source, emergency power source, emergency, standby, or backup source).

**Source 1: Failed or Fails**

Source 1 is defined as “failed” when it is outside of its under-voltage/overvoltage/ underfrequency/overfrequency (if applicable) setpoint ranges for the nominal voltage and frequency setting.

**Source 2: Failed or Fails**

Source 2 is defined as “failed” when it is outside of its under-voltage/overvoltage/ underfrequency/overfrequency (if applicable) setpoint ranges for the nominal voltage and frequency setting for a time exceeding 0.5 seconds after the Time Delay Emergency Fail (TDEF) time delay expires.

**Transfer**

Transfer is defined as a change of the load connection from the Source 1 to the Source 2 power source, except when specifically used as “Transfer to Neutral”.

**Transfer to Neutral**

Transfer to Neutral is defined as when the load circuits are disconnect from both the Source 1 and Source 2 power sources.

**Unconnected**

Unconnected is defined as when the input is not shorted by an external contact or connection.

## SECTION 2: RECEIVING, HANDLING, AND STORAGE

### 2.1 Receiving

Every effort is made to ensure that the ATS equipment arrives at its destination undamaged and ready for installation. Packing is designed to protect internal components as well as the enclosure. Care should be exercised, however, to protect the equipment from impact at all times. Do not remove the protective packaging until the equipment is ready for installation.

When the ATS equipment reaches its destination, the customer should inspect the shipping container for any obvious signs of rough handling and/or external damage that occurred during transportation. Record any external and internal damage for reporting to the transportation carrier and Eaton, once a thorough inspection is complete. All claims should be as specific as possible and include the Shop Order and General Order numbers.

A shipping label affixed to the shipping container includes a variety of equipment and customer information, such as General Order Number and Customer Number. Make certain that this information matches other shipping paper information.

Each transfer switch enclosure is bolted through its top and bottom mounting flanges to a rigid wooden pallet. The pallet is open at two ends for movement by a forklift. Heavy-duty cardboard sides surround the enclosure and are further supported with reinforced cardboard corner posts. An egg crate design cardboard protector covers the entire top of the enclosure with additional cardboard protectors over the indicating light panel and operating handle. A heavy-duty cardboard lid covers the entire opening. The shipment is secured and further protected with shrink-wrap. Do not remove or discard the packing material until the equipment is ready for installation.

Once the top packaging is removed from the shipment, the enclosure door can be opened. A plastic bag of documents will be found in the enclosure, usually attached to the inside of the door. Important documents, such as test reports, wiring diagrams, and appropriate instruction leaflets, are enclosed within the bag and should be filed in a safe place.

### 2.2 Handling

As previously mentioned, ATS equipment is packaged for forklift movement. Protect the equipment from impact at all times and DO NOT double stack.

Once the equipment is at the installation location and ready to be installed, packaging material can be removed and discarded. Once the enclosure is unbolted from the wooden pallet, it can be hand moved to its installation position. Be careful not to damage the top or bottom enclosure mounting flanges. Refer to Section 4 of this manual for specific installation instructions.

### 2.3 Storage

Although well packaged, this equipment is not suitable for outdoor storage. The equipment warranty will not be applicable if there is evidence of outdoor storage. If the equipment is to be stored indoors for any period of time, it should be stored with its protective packaging material in place. Protect the equipment at all times from excessive moisture, con-

struction dirt, corrosive conditions, and other contaminants.

It is strongly suggested that the package-protected equipment be stored in a climate-controlled environment with temperatures from -30 to 85°C (-22 to 185°F) and with a relative humidity of 80% or less. DO NOT, under any circumstance, stack other equipment on top of a transfer switch equipment enclosure, whether packaged or not.

## SECTION 3: EQUIPMENT DESCRIPTION

### 3.1 General

The ATS consists of three basic panels:

1. The power panel;
2. The voltage selection and transformer panel; and
3. The microprocessor-based logic panel.

These panels are interconnected via connector plugs and mounted in an enclosure (Figure 6).

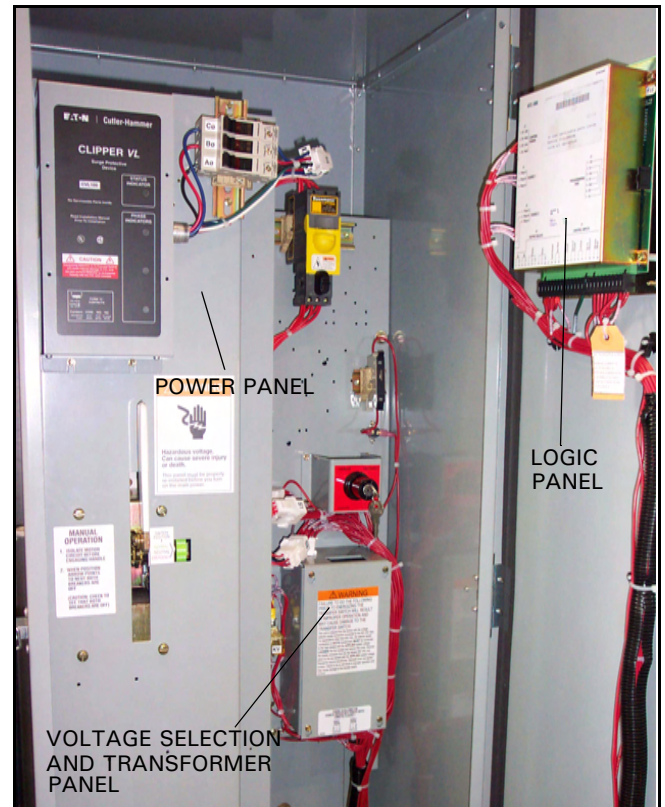

Figure 6. Three Basic Panels of the ATS (225-1200 A).

### 3.2 Power Panel

The power panel is used for making load, power, and neutral connections. The main contacts and the transfer mechanism are all on one steel frame (Figures 7 and 8).

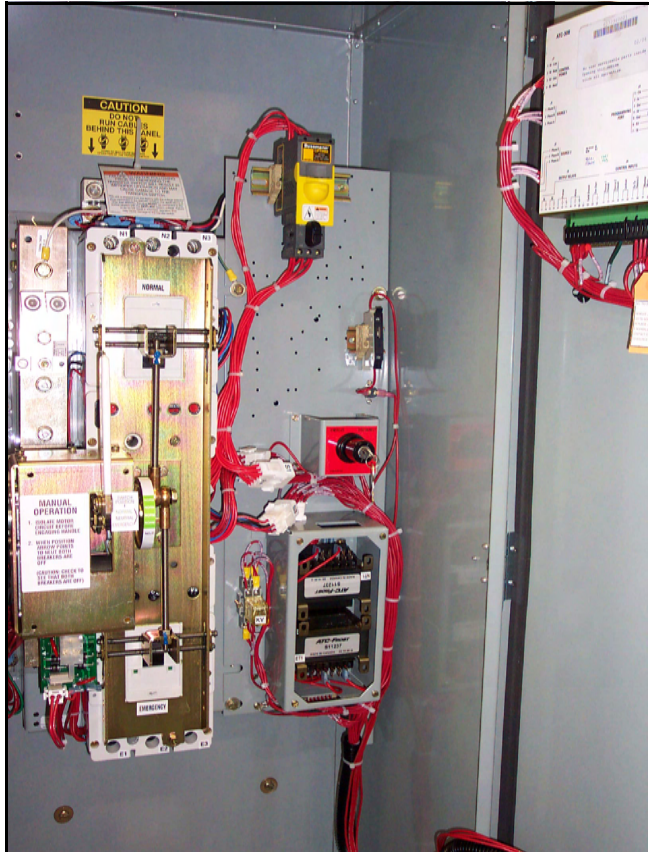

Figure 7. Typical Power Panel for 225-1200 A Models.

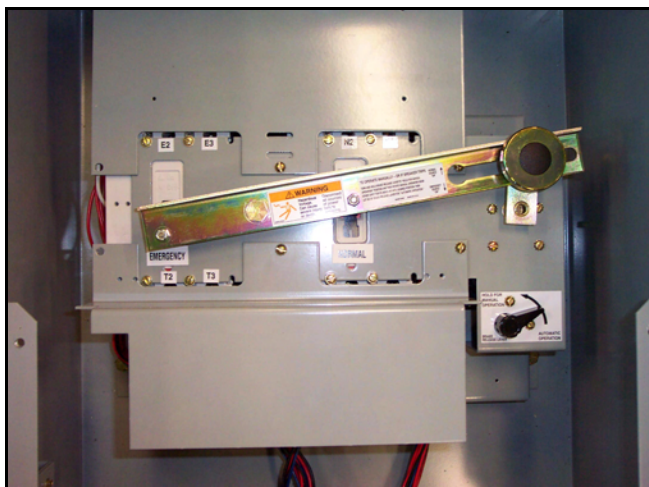

Figure 8. Typical Power Panel for 30-150 A Models.

**3.2.1 Steel Base Plate**

The steel base plate design (225-1200 A models only) permits the power panel to be moved vertically within the enclosure to accommodate top or bottom cable entry. Elongated holes on either side of the base plate ensure proper positioning. The bottom set of elongated holes positions the power panel higher in the enclosure, thus permitting bottom cable entry. The top set of elongated holes positions the power

panel lower in the enclosure for top cable entry. Section 4 discusses equipment mounting and load lug location in detail.

**3.2.2 Main Contacts**

This ATS incorporates Eaton-type molded case switches. The main contacts connect and disconnect the load to and from the different power sources. High-withstand molded case switches are the main contacts for the Source 1 and Source 2 power sources in standard switch ATSs (Figure 9 and Section 3.7). These continuous duty transfer switches are rated for all classes of loads, open or enclosed.

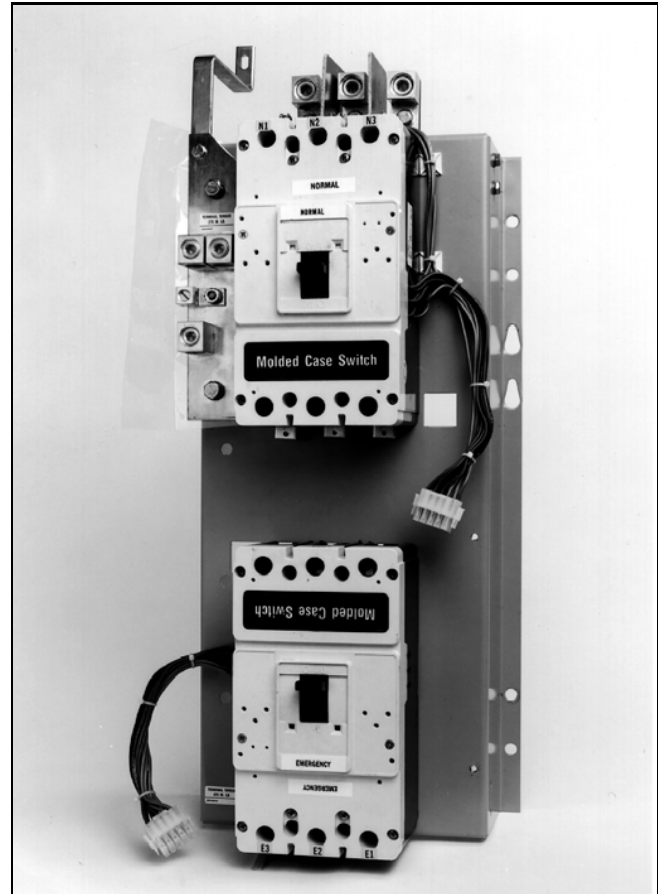
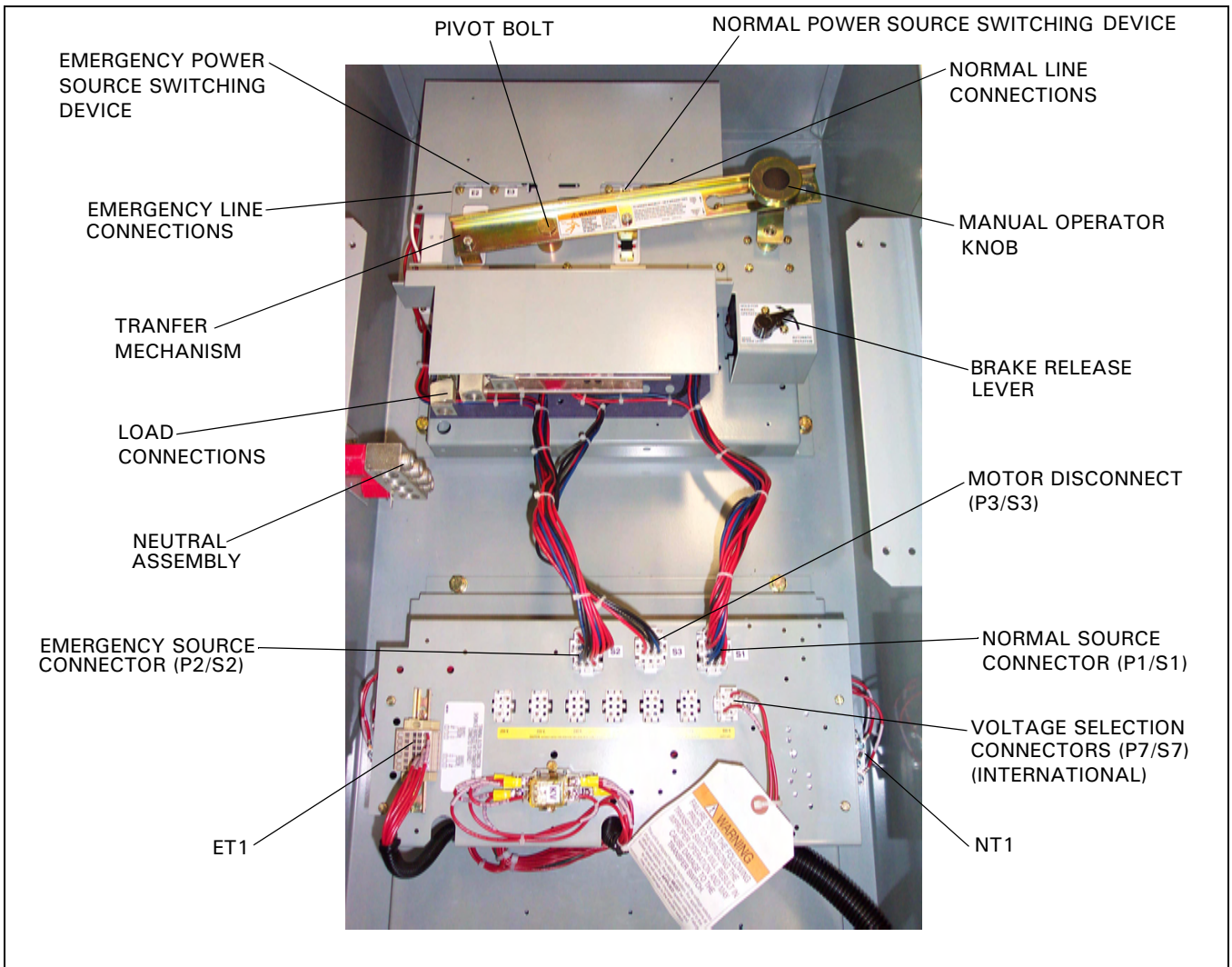

Figure 9. Mounted Molded Case Switches with the Transfer Mechanism Removed for Clarity (225-1200 A Models).

In addition, they have high dielectric strength, heavy-duty switching, high-withstand capabilities, and high interruption capacity.

The switching devices are mechanically and electrically interlocked to prevent the two sets of main contacts from being closed simultaneously. The load side contacts of each switching device are joined with a bus bar assembly to form a common load terminal location, either top or bottom (Figures 10 and 11).



**Figure 10. Typical (30-150 A) Horizontal Design Transfer Switch Equipment (Door Open).**

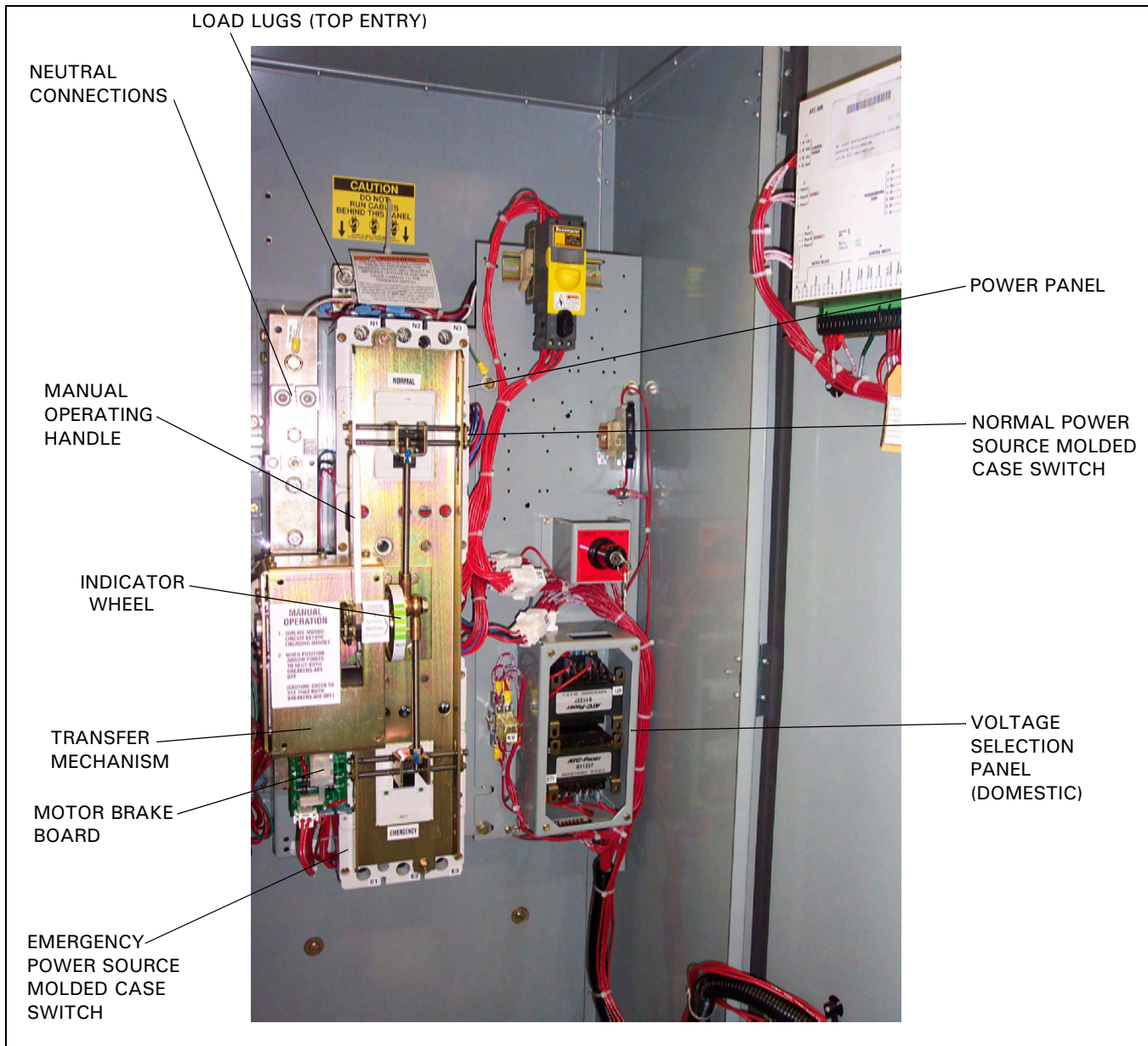

Figure 11. Typical (225-1200 A) Vertical Design Transfer Switch Equipment (Door Open and Deadfront Cover Removed).

3.2.3 Transfer Mechanism (225-1200 A)

The transfer mechanism transfers between power sources through a motor-driven, ratchet-type operation. A rotational motion is created on an indicator wheel by the ratchet's operation. The indicator wheel is attached to rigid shafts that convert the rotary motion into vertical linear motion. Opening and closing the switching devices is accomplished as a result of this vertical linear motion. The transfer mechanism is mounted in front of the molded case switches (Figure 6).

A solid steel shield (Deadfront Cover) attached to the ratchet assembly permits viewing of the rotary switch position indicator while restricting access to other parts of the power panel (Figure 12).

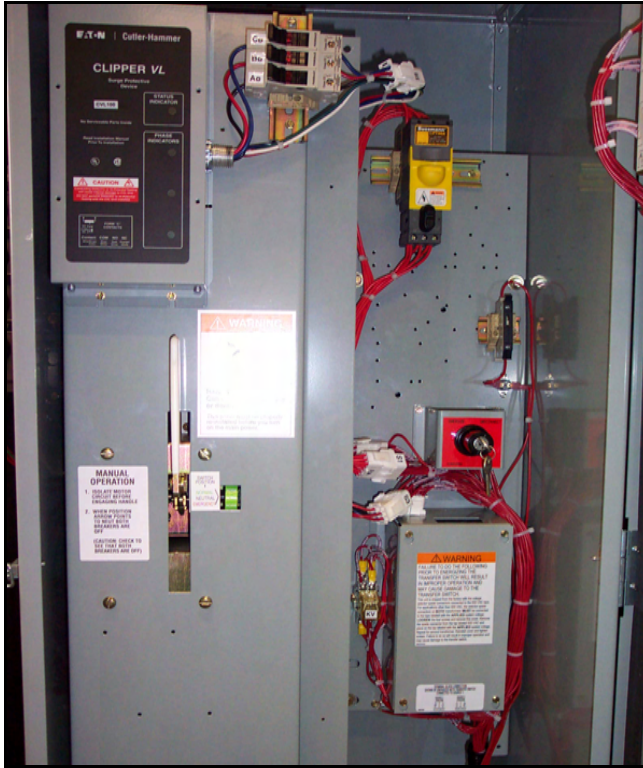

Figure 12. Vertical Design ATS Equipment with Deadfront Cover in Place Over the Power Panel (225-1200 A)

### 3.2.4 Transfer Mechanism (30-150 A)

This mechanism transfers between power sources using a motor-driven arm that connects to a lever that operates both the Source 1 and Source 2 switches (Figure 8).

## 3.3 Voltage Selection

### 3.3.1 North American Voltage Selection (120, 208, 240, 480, and 600 V, - 60 Hz)

The North American market voltage selection panel consists of multi-tap transformers, contained in a steel case mounted in the enclosure (Figure 13). The cover has "teardrop" holes for the screws to allow easy access to the transformers. The voltage is selected by simply removing the wires from the default primary taps of both transformers and installing them on the primary taps for the desired voltage. Taps are provided for 120 to 600 Vac to satisfy any required North American market application voltage. The factory default position is 600 Vac.

## ⚠ CAUTION

WHEN CHANGING THE SELECTED VOLTAGE, THE POWER MUST BE REMOVED FROM THE ATS AND THE WIRES MUST BE MOVED ON THE TAPS OF BOTH TRANSFORMERS.

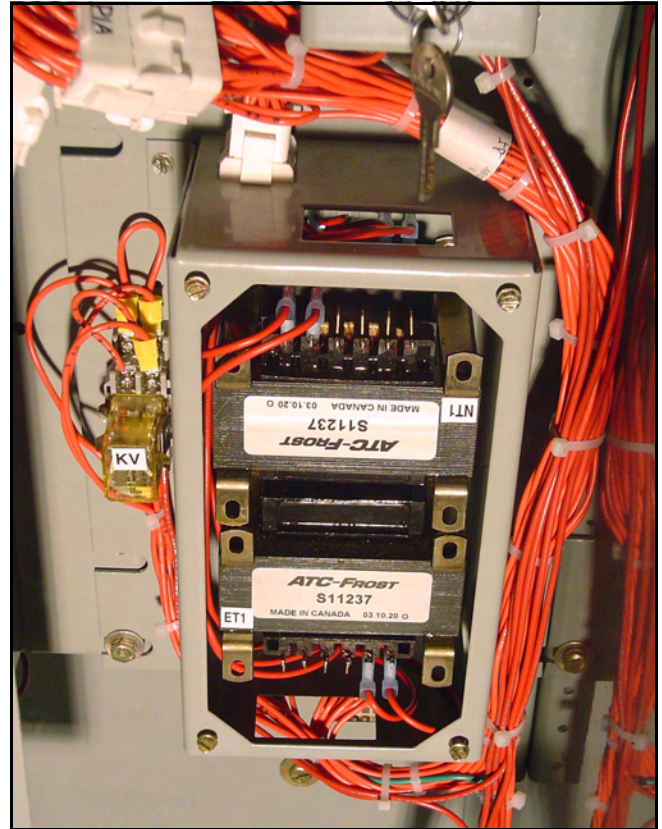
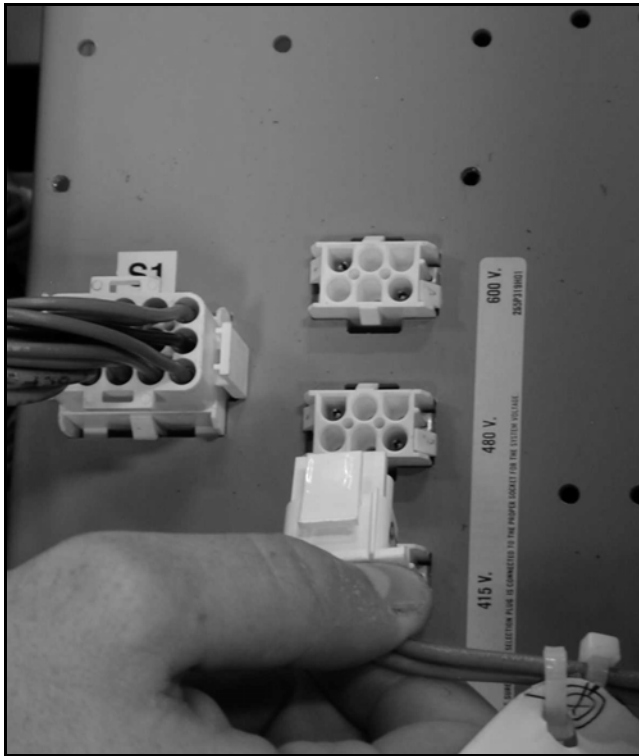

Figure 13. North American Market Voltage Selection Terminals (Shown Connected to the 120 Vac Taps).

**3.3.2 International Voltage Selection (208, 220, 240, 380, 415, and 600 V - 50-60 Hz)**

The International market voltage selection panel is a multi-tap, enclosed transformer mounted in the enclosure (Figure 14). Seven front accessible voltages taps from 208 to 600 Vac satisfy any required International market application voltage. A quick-change capability from one voltage to another is provided by a small disconnect plug. The factory default position is 600 VAC.



**Figure 14. International Market Vertical Design Voltage Selection Panel with Voltage Being Selected.**

**3.4 ATC-300 Logic Panel**

The ATC-300 is a microprocessor-based transfer switch logic control package. The hardware and software of the controller contain the intelligence/supervisory circuits that constantly monitor the condition of the power sources. It provides the intelligence necessary for the operation of the ATS (Figure 15).



**Figure 15. ATC-300 Logic Control Panel.**

The ATC-300 controller has an operating temperature of -20 to 70°C (-4 to 158°F).

The controller circuit board is protected by an insulating conformal coating.

The specifications, under normal operating conditions, are as follows:

- Tolerance for voltage sensing function: ± 1% of setting
- Tolerance for frequency sensing function: ± 0.3 Hz of setting

### 3.5 Features

A variety of standard and optional features are available for Eaton ATCs. **All features or combinations of features may not be available on specific ATCs.** All features and/or accessories are Underwriters Laboratories (UL) listed unless noted.

#### 3.5.1 Standard Features

The following is a list of the standard features for the ATC-300 Controlled ATS.

- 1. Time Delay Normal to Emergency (TDNE)**

This feature provides a time delay when transferring from the Source 1 to the Source 2 power source. Timing begins when Source 2 becomes available. It permits controlled transfer of the load circuit to Source 2.

Adjustable 0 - 1800 Seconds
  - 2. Time Delay on Engine Starting (TDES)**

This feature provides a time delay of the signal to initiate the engine/generator start cycle in order to override momentary power outages or voltage fluctuations of Source 1.

Adjustable 0 - 120 Seconds
  - 3. Time Delay Emergency to Normal (TDEN)**

This feature provides a time delay of the re-transfer operation to permit stabilization of Source 1. Timing begins when Source 1 becomes available. If Source 2 fails during timing, then re-transfer is immediate overriding the time delay.

Adjustable 0 - 1800 Seconds
  - 4. Time Delay for Engine Cool-down (TDEC)**

This feature provides a time delay of the signal to initiate the engine/generator stop cycle after the re-transfer operation. This allows the engine/generator to cool down by running unloaded. Timing begins on completion of the re-transfer cycle.

Adjustable 0 - 1800 Seconds
  - 5. Source 2 Monitoring and Protection**

This feature provides monitoring and protection based on the Source 2 voltage and/or frequency setpoints. All feature 5 functions are Failsafe operations.
  - 5B. Single Phase Undervoltage and Underfrequency Protection**

Adjustable Undervoltage:  
Dropout: 50 - 97% of nominal  
Pickup: (Dropout + 2%) to 99% of nominal

Adjustable Underfrequency:  
Dropout: 90 - 97% of nominal  
Pickup: (Dropout + 1Hz) to 99% of nominal
  - 5J. Three Phase Undervoltage and Underfrequency Protection**

Adjustable Undervoltage:  
Dropout: 50 - 97% of nominal  
Pickup: (Dropout + 2%) to 99% of nominal

Adjustable Underfrequency:  
Dropout: 90 - 97% of nominal  
Pickup: (Dropout + 1Hz) to 99% of nominal
  - 6. Test Operators**

Eaton ATCs are provided with a Test Pushbutton that simulates a loss of the Source 1 power source as standard (Feature 6B). All programmed time delays (TDNE, TDEN, etc.) will be performed as part of the Test. Engine run time of the Test is equal to the Plant Exerciser (Feature 23) programmed setpoint. All Tests are Failsafe protected.
  - 6B. Test Pushbutton**

Programmable Setpoints include:

    1. Load or No Load Testing, or Disabled
    2. Engine run time equal to the plant exerciser (Feature 23) setting
  - 7. Time Delay Emergency Fail (TDEF)**

This feature provides a time delay that prevents a connected Source 2 power source from being declared "Failed" in order to override momentary generator fluctuations. If the Source 2 power source remains in the failed state then, 0.5 seconds after the TDEF timer expires, the transfer switch will proceed with the programmed sequence for retransfer. This time delay is only implemented when the Source 2 power source is a generator.

Adjustable 0 - 6 Seconds
  - 8. Time Delay Bypass Pushbutton**

This feature provides a way (by pushing the Help and Step pushbutton simultaneously) to bypass the TDNE (Feature 1) and/or TDEN (Feature 2) time delays. The Time Delay Bypass function, when activated by pushing the Help and Step pushbutton simultaneously, will reduce any or all of the programmed time delay to zero.
  - 8C. Bypass TDEN**

This feature provides one set of pushbuttons to bypass the TDEN time delay.
  - 8D. Bypass TDNE**

This feature provides one set of pushbuttons to bypass the TDNE time delay.
  - 12. Power Source Annunciation**

This feature provides LEDs to give switch position and power source availability indications.
- Switch Position**
- Provides LEDs to indicate the switch position.

**12C. Source 1 - Source Connected**

This feature provides a green LED that, when lit, indicates the load is connected to Source 1.

**12D. Source 2 - Source Connected**

This feature provides a red LED that, when lit, indicates the load is connected to Source 2.

**Power Source Availability**

Provides LEDs to indicate if a power source is available. LEDs may be integral or separate from the controller.

**12G. Source 1 - Available**

This feature provides a white LED that, when lit, indicates Source 1 is available.

**12H. Source 2 - Available**

This feature provides an amber LED that, when lit, indicates Source 2 is available.

**15. Switch Position Indication Contact**

This feature provides a contact that indicates if the power switching device is in the "Open" or "Closed" position.

**15E. Source 1 Position Indication Contact**

This feature provides 1 dry Form "C" contact that indicates the position of the Source 1 power switching device.

**15F. Source 2 Position Indication Contact**

This feature provides 1 dry Form "C" contact that indicates the position of the Source 2 power switching device.

**21. Optional Power Cable Connection Terminals**

Eaton Transfer Switches are provided as standard with Source 1, Source 2, and Load Circuit solderless screw-type terminals for power cable connection. Alternate terminal wire sizes may be available dependant on transfer switch type and ampere rating.

**21A. Optional Power Cable Connection Terminals**

This feature provides alternate power cable connection terminals. Consult Eaton for available optional terminal sizes.

**23. Plant Exerciser (PE)**

This feature provides a means for automatic testing of the engine generator set or standby power system. All programmed time delays will be performed during plant exerciser operations.

**23K. Plant Exerciser Selectable – Disabled/1/7/14/28 Day Interval**

This feature provides for automatic test operation of the generator. Available test cycles are daily, 7, 14, or 28 days with duration equal to the programmed engine test time.

Programmable setpoints allow for selection of three test cycles:

- Engine Start/Run Only (No Load);
- Exercise with Load Transfer; or
- Disabled

This is a "Failsafe" operation.

**26. Source 1 - Monitoring and Protection**

This feature provides Source 1 monitoring and protection functions. If the Source 1 power supply fails, then the Automatic Transfer Controller will begin the sequence of operations necessary to transfer the load circuit to the Source 2 power supply. All Feature 26 monitoring and protection functions are Failsafe operations.

**26A. All Phase Undervoltage Protection**

This feature provides all phase undervoltage monitoring and protection.

Adjustable Undervoltage:  
Dropout: 50-97% of nominal  
Pickup: (Dropout + 2%) to 99% of nominal

**26D. Go to Source 2**

This feature provides the capability for an external contact opening to initiate a load circuit transfer to the Source 2 power source. This includes starting the engine/generator, performing the programmed time delays, and the transfer operation. Re-transfer will occur when the external contact is closed or under a Failsafe condition.

**29. Alternate Transfer Modes of Operation**

Provides standard or optional transfer modes, mode selection devices, and operational methods for Transfer Switches.

**29A. Automatic Operation**

Provides fully automatic transfer, re-transfer, and engine/generator startup and shutdown operations.

**32. Delayed Transition Transfer Modes for Open Transition Transfer Switches**

This feature provides delayed transition transfer modes for an open transition transfer switch. Often used in systems with inductive loads, a delayed transition transfer switch may prevent or reduce inrush currents due to out of phase switching of inductive loads.

**32A. Time Delay Neutral**

This feature provides a time delay in the neutral position during the transfer and re-transfer operations during which both Source 1 and Source 2 are disconnected from the load circuit. The time delay is programmable and is the same for both transfer and re-transfer operations.

Adjustable 0 - 120 Seconds

**35. Pre-Transfer Signal**

This feature provides a signal to a remote device prior to a re-transfer operation. It provides one Form "C" contact (NO/NC) for interface with other equipment (typically elevator controls). The contacts close/open

on a timed basis prior to transfer in either direction. After TDNE/TDEN times out, this relay closes and the Pre-transfer Timer (TPRE) starts timing. After the TPRE times out, the transfer proceeds by starting the TDN timer if enabled. The pre-transfer relay opens after the transfer is complete.

Adjustable 0 - 120 Seconds

### 35A. Pre-Transfer Signal with 1 N.O. and 1 N.C. Contacts

This feature provides pre-transfer signal and includes 1 N.O. and 1N.C. contacts.

### 38. Stainless Steel Covers

Provides an added level of security by providing a pad lockable stainless steel cover for use with standard transfer switch logic controllers and/or associated device panels. These covers function with Eaton's ATC series logic controllers and device panels. The covers are designed for NEMA 1, 3R, 4X, and 12 applications.

### 42. Seismic Certification

This feature provides a Seismic certified Transfer Switch with certificate for application in Seismic Zone 4 under the California Building Code, the Uniform Building Code, and BOCA.

## 3.5.2 Optional Features

The following is a list of the optional features for the ATC-300 Controlled ATS. **All features or combinations of features may not be available on specific ATSS**

### 5. Source 2 Monitoring and Protection

This feature provides monitoring and protection based on the Source 2 voltage and/or frequency setpoints. All feature 5 functions are Failsafe operations.

### 5C. 1-Phase Overvoltage/Overfrequency

Adjustable Overvoltage:  
Dropout: 105 - 120% of nominal  
Pickup: (Dropout -2%) - 103% of nominal

Adjustable Overfrequency:  
Dropout: 103 - 110% of nominal  
Pickup: (Dropout -1Hz) - 101% of nominal

### 5D. 1-Phase Undervoltage

Adjustable Undervoltage:  
Dropout: 50 - 97% of nominal  
Pickup: (Dropout +2%) - 99% of nominal

### 5E. 1-Phase Overvoltage

Adjustable Overvoltage:  
Dropout: 105 - 120% of nominal  
Pickup: (Dropout -2%) - 103% of nominal

### 5F. 3-Phase Undervoltage

Adjustable Undervoltage:  
Dropout: 50 - 97% of nominal  
Pickup: (Dropout +2%) - 99% of nominal

### 5G. 3-Phase Overvoltage

Adjustable Overvoltage:  
Dropout: 105 - 120% of nominal  
Pickup: (Dropout -2%) - 103% of nominal

### 5H. Phase Reversal

For a 3-Phase source, this feature monitors the phase sequence of the sources. If both sources do not have the same ABC or CBA sequence, the source that is not connected will be considered "Unavailable".

### 5K. 3-Phase Overvoltage/Overfrequency

Adjustable Overvoltage:  
Dropout: 105 - 120% of nominal  
Pickup: (Dropout -2%) - 103% of nominal

Adjustable Overfrequency:  
Dropout: 103 - 110% of nominal  
Pickup: (Dropout -1Hz) - 101% of nominal

### 5L. Source 2 3-Phase Source 2 Voltage Unbalance/Loss

For a 3-Phase source, this feature monitors phase voltage ratios. Voltage unbalance (%) is calculated as the difference between the maximum and minimum phase voltage, divided by the minimum phase voltage. User-selectable setpoints are available for dropout and pickup unbalance settings (minimum 2% differential). Dropout is adjustable from 5 to 20%. Pickup is adjustable from 3 to (Dropout - 2%). A setpoint for user-selectable time delay from 10 to 30 seconds is provided. A user-selectable setpoint for enable and disable is also provided.

### 12. Power Source Annunciation

This feature provides LEDs to give switch position and power source availability indications.

### Overcurrent Trip Indication

Available only with integral Overcurrent Protection (Feature 16). (Shown on Automatic Transfer Controller Display.)

### 12L. Source 1 Tripped (Requires Feature 16) Via ATC-300 LDC-Based Display

The Automatic Transfer Controller LCD display will read "Lockout" if the Source 1 circuit breaker is in the "tripped" position.

### 12M. Source 2 Tripped (Requires Feature 16) Via ATC-300 LDC-Based Display

The Automatic Transfer Controller LCD display will read "Lockout" if the Source 2 circuit breaker is in the "tripped" position.

### 14. Relay Auxiliary Contacts

This feature provides Form "C" relay auxiliary contacts.

### 14G. Source 1 Present 1NO/1NC

This feature provides two NO and two NC contacts. The relay is energized only when the Source 1 power source is available.

**14H. Source 2 Present 1NO/1NC**

This feature provides two NO and two NC contacts. The relay is energized only when the Source 2 power source is available.

**16. Integral Overcurrent Protection**

This feature provides thermal-magnetic overcurrent protection integral to the power switching device(s). All Feature 16 options include a "Lockout" function. If the power switching breaker trips on an overcurrent condition, then "Lockout" is displayed on the Automatic Transfer Controller display and automatic operation is prevented until the appropriate source is manually reset.

**16B. Integral Overcurrent Protection on Both Power Source Switching Devices**

This feature provides integral overcurrent protection on both Source 1 and Source 2 power switching devices.

**16E. Integral Overcurrent Protection on the Source 2 Power Switching Device**

This feature provides integral overcurrent protection on the Source 2 power switching device.

**16N. Integral Overcurrent Protection on the Source 1 Power Switching Device**

This feature provides integral overcurrent protection on the Source 1 power switching device.

**18. Metering and Communications**

The IQ Family of microprocessor-based multi-function monitoring and display devices features the latest technological advances in metering and communications capabilities.

The IQ Family is available with an optional communications interface for data collection, storage, and printout via the Eaton PowerNet System. (See Feature 48 – Communications for available communication modules.)

Feature 18 metering options include all required external devices (CTs, etc.) for a fully functioning metering system.

**IQ Analyzer**

The IQ Analyzer is a RMS sensing, multi-function micro-processor-based monitoring and display device with waveform capture that provides simultaneous monitoring of current, voltage, frequency, power (real, reactive and apparent), energy (real, reactive and apparent), demand (forward, reverse and net), harmonics (magnitude and phase angle), power factor, and percent THD (current and voltage).

The meter can be mounted on Source 1, Source 2, or load. The meter can also be configured for switching between Source 1 and Source 2.

**IQ DP-4000**

The IQ DP-4000 is a RMS sensing, multi-function micro-processor-based monitoring and display device that provides simultaneous monitoring of current, voltage, frequency, power (real, reactive and apparent), energy (real, reactive and apparent), power factor, and percent THD (current and voltage).

The meter can be mounted on Source 1, Source 2, or load. The meter can also be configured for switching between Source 1 and Source 2.

**Ammeter**

A single ammeter is a true RMS sensing device that displays single phase current only.

The ammeter can be mounted on Source 1, Source 2, or load. The meter can also be configured for 1, 2, or 3 phase sensing by supplying one meter per phase for Source 1, Source 2, or load. Ammeters for both Source 1 and Source 2 can also be grouped together.

**24. Battery Charger**

Provides an automatic battery charger for engine cranking batteries. Requires a separate 100-135 Vac, 60Hz customer supplied power source.

**24C. Battery Charger with 12 VDC Output**

Provides an automatic battery charger with 12 VDC, 5 amp output.

**24D. Battery Charger with 24VDC Output**

Provides an automatic battery charger with 24 VDC, 5 amp output.

**26. Source 1 - Monitoring and Protection**

This feature provides Source 1 monitoring and protection functions. If the Source 1 power supply fails, then the Automatic Transfer Controller will begin the sequence of operations necessary to transfer the load circuit to the Source 2 power supply. All Feature 26 monitoring and protection functions are Failsafe operations.

**26C. All Phase Overvoltage Protection**

Provides all phase overvoltage monitoring and protection.

Adjustable Overvoltage:  
Dropout: 105-120% of nominal  
Pickup: (Dropout -2%) to 103% of nominal

**26E. All Phase Underfrequency Protection**

Provides all phase underfrequency monitoring and protection.

Adjustable Underfrequency:  
Dropout: 90-97% of nominal  
Pickup: (Dropout + 1Hz) to 99% of nominal

**26F. All Phase Overfrequency Protection**

Provides all phase overfrequency monitoring and protection.

Adjustable Overfrequency:  
Dropout: 103-110% of nominal  
Pickup: (Dropout -1Hz) to 101% of nominal

**26H. Phase Reversal Protection**

For a 3-phase source, this feature monitors the phase sequence of the sources. If a source does not have the same ABC or CBA sequence as the phase reversal setpoint, the source will be considered "Unavailable".

**26L. Source 1 3-Phase Voltage Unbalance/Loss**

For a 3-Phase source, this feature monitors phase voltage ratios. Voltage unbalance (%) is calculated as the difference between the maximum and minimum phase voltage, divided by the minimum phase voltage. User-selectable setpoints are available for dropout and pickup unbalance settings (minimum 2% differential). Dropout is adjustable from 5 to 20%. Pickup is adjustable from 3 to (Dropout - 2%). A setpoint for user-selectable time delay from 10 to 30 seconds is provided. A user-selectable setpoint for enable and disable is also provided.

**29. Alternate Transfer Modes of Operation**

Provides standard or optional transfer modes, mode selection devices, and operational methods for Transfer Switches.

**29G. Automatic/Manual Operation with Selector Switch**

This feature provides a 2-position selector switch (labeled Auto/Manual) that permits selection of the automatic or manual transfer operation mode. When in the "Auto" position, the transfer switch operates with fully automatic transfer, re-transfer, and engine/generator start up and shut down operations. When in the "Manual" position, manual start-up of the engine/generator and manual transfer are required (see Section 5 for manual operation of the transfer switch). Manual shut-down of the engine/generator are also required. The selector switch for manual operation is provided.

**Note:** Transfer switches with Feature 29G MUST be labeled as Non-Automatic Transfer Switch Equipment.

**34. Logic Extender Cable**

Provides logic extender cables with connectors which permit remote mounting of the transfer panel and Automatic Transfer Controller in non-standard applications.

**34B. 72 Inches (1829 mm)**

Provides logic extender cable with connectors.

**37. Service Equipment Rated Transfer Switch**

This feature provides the label "Suitable for use as Service Equipment" and the features necessary to meet the requirements for the label. It includes the service disconnect with visible indication and neutral assembly with removable link. **Features 16B or 16N must be selected separately.**

**37A. Service Equipment Rated Transfer Switch Without Ground Fault Protection (30 – 1000 A)**

This feature provides Service Equipment rating for an application that does not require ground fault protection.

**37B. Service Equipment Rated Transfer Switch With Ground Fault Protection (800 – 1000 A)**

This feature provides Service Equipment rating for an application that requires ground fault protection.

**38. Stainless Steel Logic Cover****38C. SS ATC-300 Cover**

This feature provides a pad-lockable stainless steel cover for the ATC-300 Controller.

**39. Feeder Breakers****39A. Two 200 A Feeder Breakers**

This feature provides two (2) 200 A feeder breakers for the 200 A ATH3 transfer switch.

**39B. Three 200 A Feeder Breakers**

This feature provides three (3) 200 A feeder breakers for the 300 A ATH3 transfer switch.

**39C. Four 200 A Feeder Breakers**

This feature provides four (4) 200 A feeder breakers for the 400 A ATH3 transfer switch.

**41. Space Heater With Thermostat**

This feature provides a space heater and non-adjustable thermostat. External control power is not required.

**41A. Space Heater With Thermostat - 100 Watt**

This feature provides a 100 watt (W) space heater with a non-adjustable thermostat.

**51D. CVL050 Surge Device**

This feature provides a 50 KA, 600 Vac, 3 Ohm surge device. It can be mounted on the Source 1 line, the Source 2 line, both the Source 1 and Source 2 lines, or on the load line.

**51E. CVL080 Surge Device**

This feature provides an 80 KA, 600 Vac, 3 Ohm surge device. It can be mounted on the Source 1 line, the Source 2 line, both the Source 1 and Source 2 lines, or on the load line.

**51F. CVL100 Surge Device**

This feature provides a 100 KA, 600 Vac, 3 Ohm surge device. It can be mounted on the Source 1 line, the Source 2 line, both the Source 1 and Source 2 lines, or on the load line.

**51G. CHSPMAX**

This feature provides a 50 KA, 240/120 Vac, 1 Ohm surge device. It can be mounted on the Source 1 line, the Source 2 line, both the Source 1 and Source 2 lines, or on the load line.

**51H. CHSPULTRA**

This feature provides a 70 KA, 240/120 Vac, 1 Ohm surge device. It can be mounted on the Source 1 line, the Source 2 line, both the Source 1 and Source 2 lines, or on the load line.

**51J. Telephone Surge Protection**

The telephone line surge protection feature offers 4-pair telephone line protection. The features ship loose for customer mounting convenience.

**51K. Cable Surge Protection**

The TV and satellite cable surge protection feature offers 2 coaxial line protection (cable/satellite TV). The features ship loose for customer mounting convenience.

**51M. DC Surge Protection for Engine Start Connections**

This feature provides a 39 KA, 12 Vdc, surge device. This device will reduce a 6000 V transient to 80 V.

This feature provides a 39 KA, 24 Vdc, surge device. This device will reduce a 6000 V transient to 80 V.

These features ship loose for customer mounting convenience.

**3.6 Enclosure**

The rugged steel ATS enclosure is supplied with three door hinges, regardless of enclosure size. They ensure proper support of the door and door mounted devices (Figure 16). The hinges have removable hinge pins to facilitate door removal. Certain procedures, such as switch mounting, are simplified with the door removed. The doors are supplied as standard with pad-lockable latches.



Figure 16. Typical Type 1 Enclosure (Door Closed).

The door is used to mount a variety of lights, switches, and push-buttons, depending upon the options required for a particular ATS. All lights and switches are mounted in the plastic door-mounted panel.

The rear of the enclosure is supplied with teardrop shaped holes in the top and bottom mounting flanges to facilitate mounting. It is also supplied with two positioning bolts and various pre-tapped inserts to insure proper positioning of the power panel anytime the power panel must be repositioned to accommodate a different cable entry position. Cable entry holes are the responsibility of the customer.

ATS enclosures and all internal steel mounting plates, such as the power panel mounting plate, go through a pretreatment cleaning system prior to painting to ensure a durable finish.

The standard ATS enclosure is NEMA Type 3R for general outdoor use. However, a variety of enclosures are available to address almost any environmental circumstance (see Table 2).

Table 2. Transfer Switch Equipment Enclosures

NEMA TYPE	DESIGN	PROTECTION
Open	Indoor	
3R	Outdoor	Rain, Ice Formation
4/4X	Outdoor	Hose Down, Non-corrosive
12	Indoor	Dust, Dirt and Non-Corrosive Liquids

**3.7 Standards**

Eaton ATS equipment, enclosed in any of the enclosures listed in Table 2, is listed for application by UL and ULC. In addition, Eaton ATSS are listed in File E38116 by Underwriters Laboratories, Inc. under Standard UL 1008. This standard covers requirements for automatic transfer switches intended for use in ordinary locations to provide lighting and power as follows:

- a. In emergency systems, in accordance with articles 517 and 700 in the National Electrical Code, ANSI/NFPA 70, and the National Fire Protection Association No. 76A; and/or
- b. In standby systems, in accordance with article 702 of the National Electrical Code; and/or
- c. In legally required standby systems in accordance with article 701 of the National Electrical Code.

Eaton ATSS are available to meet NFPA 110 for emergency and standby power systems, and NFPA 99 for health care facilities when ordered with the appropriate options.

Since Eaton ATSS use specially designed molded case switches or circuit breakers the main power switching contacts, these devices must also be listed under the additional UL Standards 1087 and 489. UL uses two basic types of listing programs - label service and reexamination.

UL1087 and 489 employs a label service listing program which requires an extensive follow-up testing program for listed devices. Standard UL 1008 for ATSS lists devices under the reexamination program which only require a continual physical reexamination of the components used in the product to ensure consistency with the originally submitted device. Follow-up testing is not required by UL 1008.

Representative production samples of molded case switches and molded case circuit breakers used in Eaton ATCs are subjected to a complete test program identical to the originally submitted devices on an ongoing, periodic basis per UL 1087 and 489. The frequency of such a re-submittal can be as often as every quarter for a low ampere device.

## SECTION 4: INSTALLATION AND WIRING

### 4.1 General

Eaton ATCs are factory wired and tested. Installation requires solidly mounting the enclosed unit and connecting power cables and auxiliary pilot circuits. Physical mounting procedures and power cable connections are covered in this section. All other required wiring or electrical connection references are covered in a separate Customer Wiring Booklet packaged with the ATC.

Locate the wiring schematic, review it, and keep it readily available for reference purposes during installation and testing. Once an ATC is properly installed and wired, it should be mechanically and electrically checked for proper installation and operation. The procedures for these initial mechanical and electrical checks are outlined in Section 6 of this instruction manual.

### NOTICE

TO FACILITATE THE PROCEDURES DESCRIBED IN THIS SECTION, THE SOLID STEEL SHIELD OVER THE POWER PANEL SHOULD BE REMOVED. THE SHIELD IS ATTACHED TO THE RATCHET ASSEMBLY WITH FOUR SCREWS. REMOVE THE FOUR SCREWS AND SHIELD UNTIL THE PROCEDURES ARE COMPLETED.



### WARNING

BE CERTAIN THAT THE SOLID STEEL POWER PANEL SHIELD IS PROPERLY INSTALLED BEFORE THE TRANSFER SWITCH EQUIPMENT IS PUT INTO SERVICE. THE SHIELD PROVIDES PROTECTION FROM DANGEROUS VOLTAGES AT THE LINE AND LOAD TERMINALS WHEN THE EQUIPMENT IS IN OPERATION. FAILURE TO DO SO COULD RESULT IN PERSONAL INJURY OR DEATH.

### 4.2 Mounting Location

Choose a location that offers a flat, rigid mounting surface capable of supporting the weight of the enclosed ATC equipment. For standard ATCs, avoid locations that are moist, hot, or dusty. However, Eaton offers optional enclosure designs that can be used in special environments. If there are any doubts as to a location's suitability, discuss them with your Eaton representative.

Check to make certain that there are no pipes, wires, or other mounting hazards in the immediate mounting area that could create a problem.

Carefully remove all packing material from the ATC at the mounting location. Even though an equipment inspection should have been made when the equipment was received, make another careful inspection of the enclosure and the enclosed ATC components as the packing material is removed and the enclosure readied for mounting. Be especially alert for distorted metal, loose wires, or damaged components.

### 4.3 Mounting Procedure

**! CAUTION**

**SINCE THE ENCLOSED ATS MUST BE LIFTED INTO PLACE FOR MOUNTING, BE CERTAIN THAT ADEQUATE RESOURCES ARE AVAILABLE FOR LIFTING TO AVOID PERSONNEL INJURIES OR EQUIPMENT DAMAGE.**

All vertical design ATS equipment enclosures and power panels are of the same design. Only the overall physical dimensions change. Note that the enclosure is provided with four teardrop (elongated) mounting holes, two in the top mounting flange and two in the bottom. Also notice that the power panel has two sets of mounting holes. One set positions the power panel for top entry of cables and one set for bottom entry. This will be covered in more detail in Section 4.4.

Eaton ATS equipment is assembled and supplied as standard for top entry (see Figure 17), although equally adaptable to bottom entry. Cable entry holes are not part of the enclosure when shipped from the factory and must be provided in the field, either before or after mounting the enclosure.

**! CAUTION**

**EXTREME CARE SHOULD BE TAKEN TO PROTECT THE TRANSFER SWITCH FROM DRILL CHIPS, FILINGS, AND OTHER CONTAMINANTS WHEN MAKING THE CABLE ENTRY HOLES. EXTREME CARE SHOULD ALSO BE TAKEN WHEN MOUNTING THE ENCLOSURE TO PREVENT COMPONENT DAMAGE OR A FUTURE MALFUNCTION.**

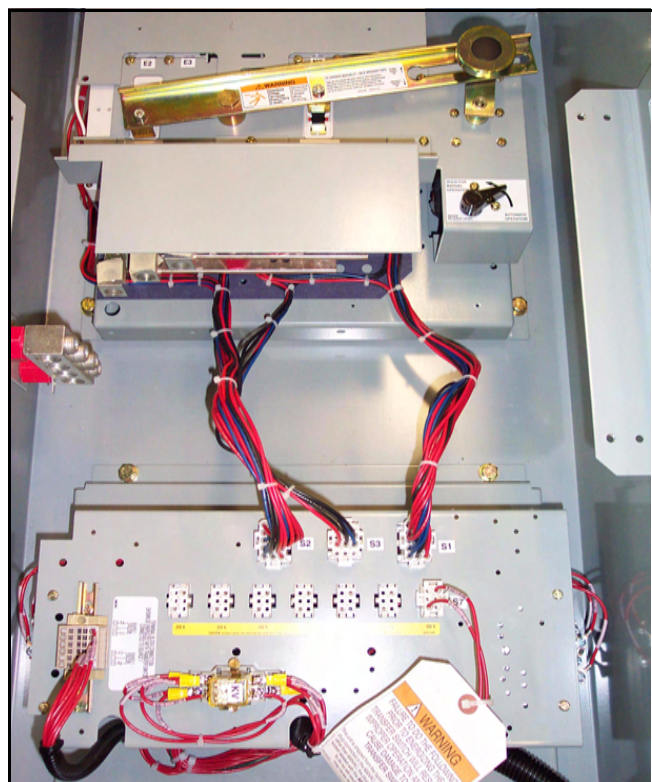

Figure 17. Typical (30-150 A) Horizontal Design ATS Equipment (Door Open).

With the enclosed ATS equipment unpacked and ready for mounting, proceed with the following steps.

- Step 1:** The ATS enclosure door is hinge mounted with removable hinge pins. To simplify the mounting procedure and avoid damaging the door-mounted logic panel, it is strongly suggested that the door be carefully removed and put it in a safe place until mounting is complete. To remove the door, open the door and disconnect the connectors at the back of the ATC-300 logic panel. Remove the wire ties securing the harness to the inside of the door. Carefully remove the hinge pins then the door from the enclosure.
- Step 2:** Install the required upper and lower mounting bolt anchors and the two upper mounting bolts in the mounting surface.
- Step 3:** Gently lift the enclosure and guide the teardrop holes in the upper mounting flange over the upper mounting bolts. Do not completely tighten the bolts at this time.
- Step 4:** While still supporting the enclosure, install the two lower mounting bolts in the lower mounting flange. Again, do not completely tighten the bolts at this time. Use shims, if required, to prevent deformation of the enclosure if the mounting surface is distorted.
- Step 5:** Tighten all four mounting bolts after any required shimming is completed.

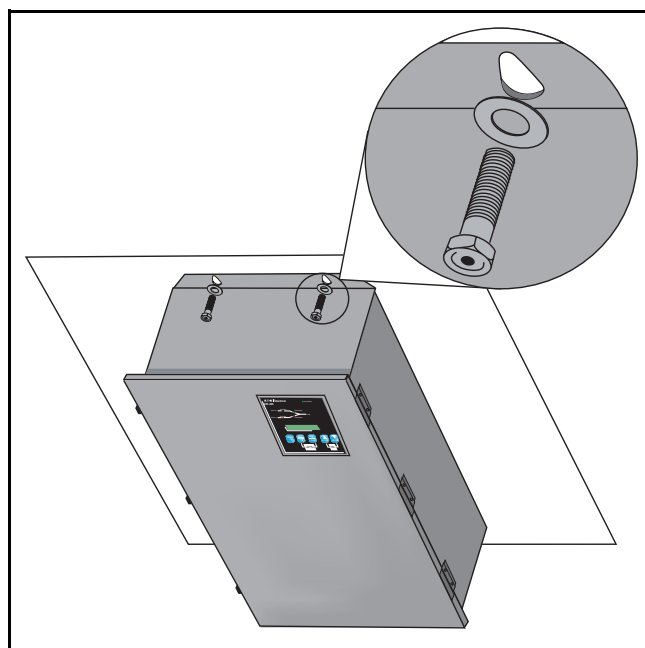

Figure 18. Typical Mounting of the ATS to a Mounting Surface.

- Step 6:** Double check to ensure that all packing and shipping materials have been removed.

### 4.4 Load Lug Location

This section applies only to the 255-1200 A switches. The load lugs for the 30-150 A switch are fixed.

ATS equipment is supplied from the factory with the load terminal lugs at the top. If the load lugs are to be repositioned to the bottom, do it at this time before wiring the unit or making power cable connections.

**⚠ WARNING**

**IF THE LOAD LUG LOCATION IS BEING CHANGED ON ALREADY INSTALLED TRANSFER SWITCH EQUIPMENT, MAKE SURE THAT THE SOURCE 1, SOURCE 2, AND OTHER POWER SOURCES CONNECTED TO THE EQUIPMENT ARE DE-ENERGIZED. HAZARDOUS VOLTAGES ARE PRESENT INSIDE ATS EQUIPMENT THAT CAN CAUSE SEVERE PERSONAL INJURY OR DEATH.**

With the solid steel shield removed, proceed with the following steps for bottom feed load termination. Refer to Figure 19 for transfer switch component names and locations.

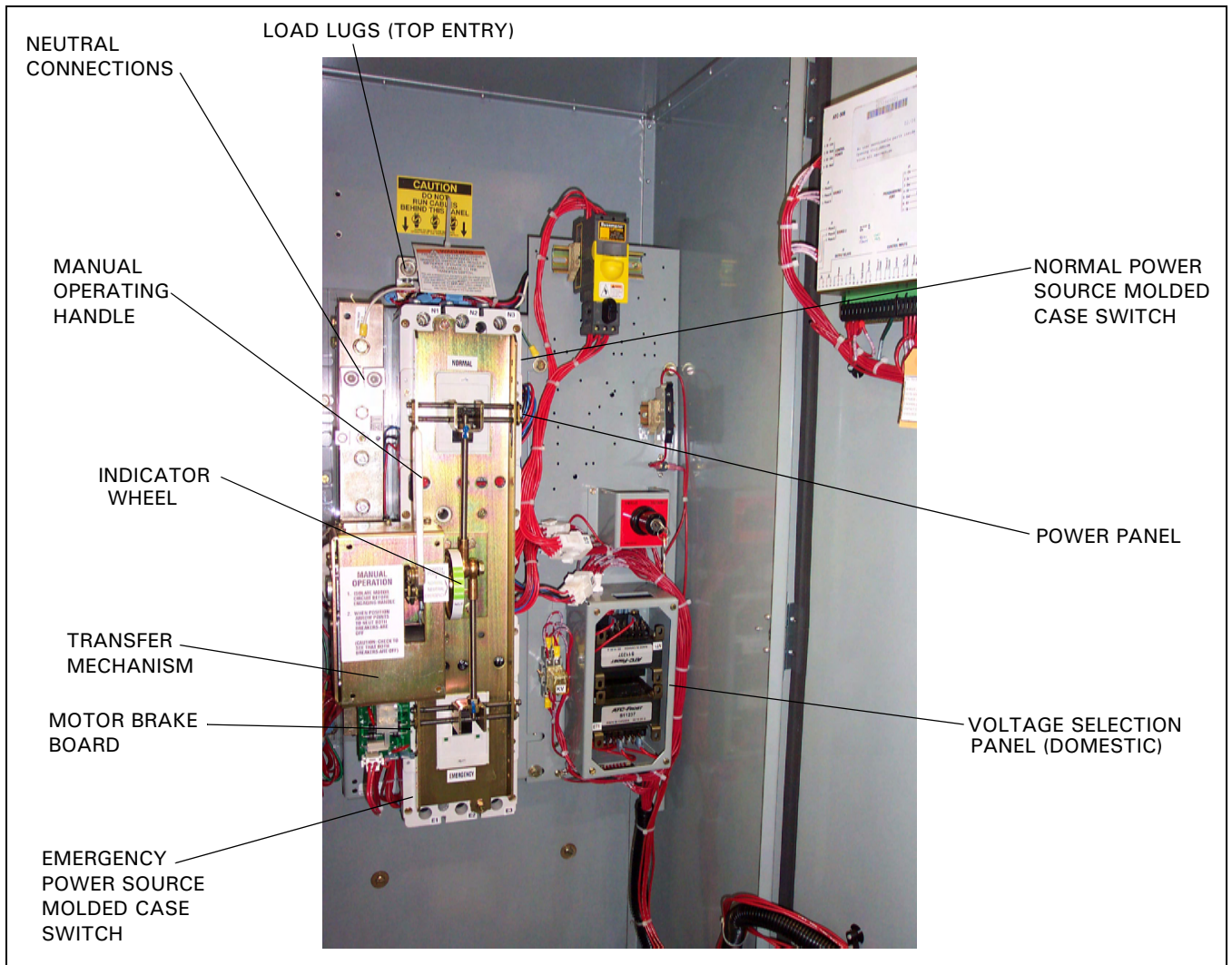

**Figure 19. Typical (225-1200 A) Vertical Design Transfer Switch Equipment (Door Open and Deadfront Cover Removed).**

**Step 1:** Disconnect the power panel from the rest of the transfer switch by unplugging the connector plugs P1, P2, and P3 (Figures 20 and 21).

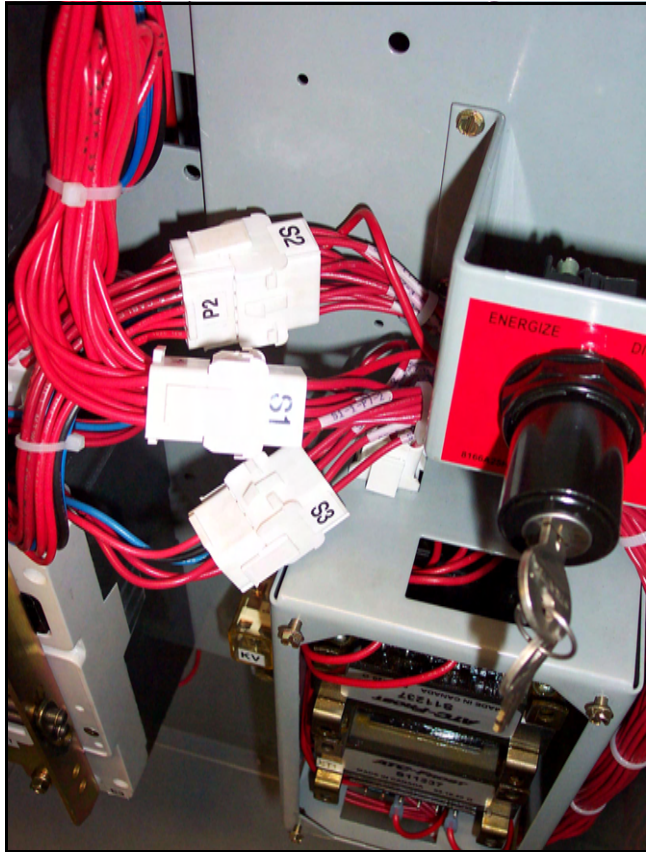

Figure 20. Location of the P1, P2, and P3 Connector Plugs for ATs with the North American Market Transformer Panel.

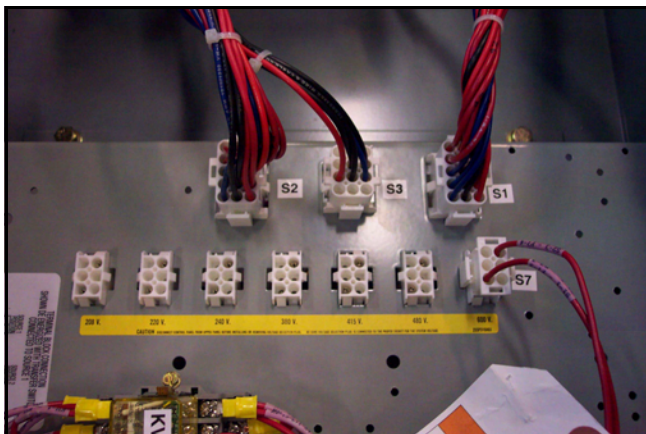

Figure 21. Location of the P1, P2, and P3 Connector Plugs for ATs with the International Market Transformer Panel.

**Step 2:** Remove the bolt that bonds the neutral strap to the rear of the enclosure, if it is in place.

**Step 3:** Remove the four bolts that secure the power panel in the enclosure. Depending upon the size of the panel, it may be advisable to have assistance with the removal. Once the power panel is free, carefully move it to a solid work surface (Figure 22).

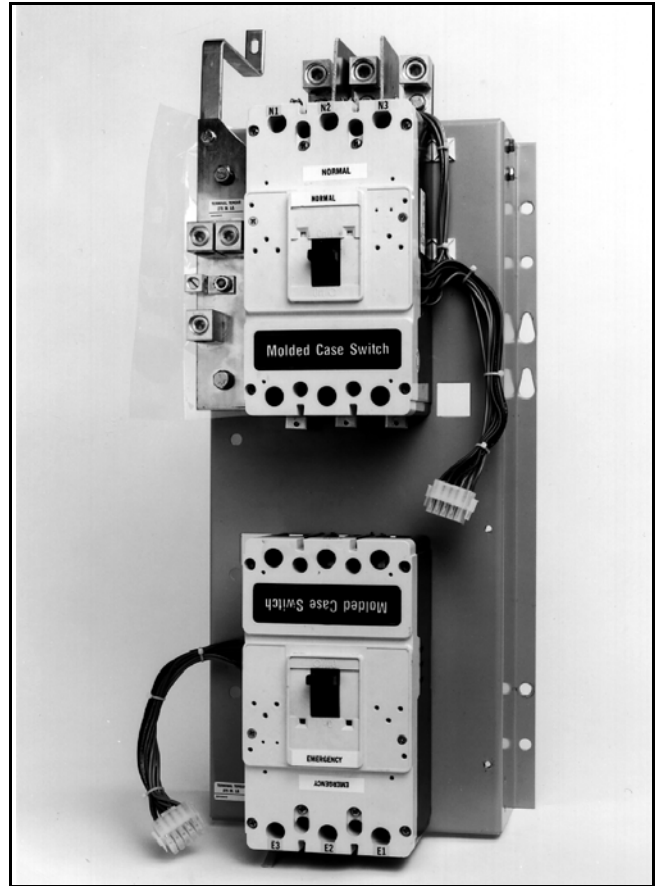

Figure 22. Power Panel Removed from the Enclosure (with the Transfer Mechanism Removed for Clarity - 225-1200 A Models).

**NOTICE**

AT THIS POINT, TAKE THE TIME TO REFER TO FIGURE 4-1 AND BECOME FAMILIAR WITH THE INSIDE REAR OF THE ENCLOSURE AND THE POWER PANEL MOUNTING PROVISIONS AVAILABLE FOR BOTH TOP AND BOTTOM ENTRY. IT WILL FACILITATE REINSTALLATION OF THE POWER PANEL.

**Step 4:** Remove the operating mechanism from the front of the power panel by removing the six bolts holding the mechanism in position. The molded case switches or optional circuit breakers should not be removed (Figure 23).

**NOTICE**

THE REAR-MOUNTED LOAD LUGS, DIP-INSULATED BUS BARS, STANDOFF INSULATORS, GLASS POLYESTER PHASE BARRIERS, AND METAL MOUNTING BRACKET ARE DESIGNED TO BE REMOVED AS ONE LOAD LUG ASSEMBLY (FIGURE 23).

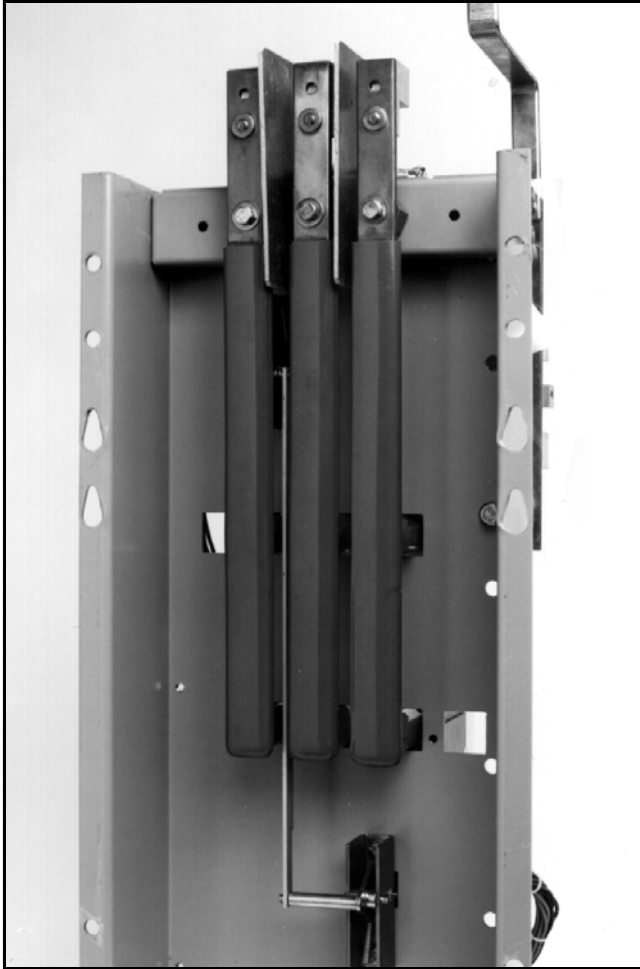

Figure 23. Mounted Load Lug Assembly (225-1200 A Models).

- Step 5:** The load lug assembly is removed by first removing the four, six, or eight bolts securing the pieces of insulated bus to the back of the power panel. The number of mounting bolts depends upon whether 2-, 3-, or 4-pole devices are installed. Mounting bolts are accessed through holes in the load end of the molded case switches or optional circuit breakers.
- Step 6:** Remove the four bolts holding the mounting bracket to the upper rear portion of the power panel. The load lug assembly can now be removed as one unit. Note that there are grooves in the back of the power panel and in the mounting bracket that keep the polyester phase barriers in their proper positions.
- Step 7:** Turn the load lug assembly 180° with the lugs at the bottom and remount the assembly by reversing the procedures described in Steps 5 and 6. The mount-

ing bracket will now be bolted to the bottom of the power panel. Make certain that all glass polyester phase barriers are in place and positioned properly in the grooves. When making any bolted connection to the bus, comply with the torque requirements as outlined in Table 3.

Table 3. Bolted Bus Connection Torque Requirements.

Power Panel Switching Device	Torque ft-lb (Nm)
Type FD	10 (14)
Type KD	20 (27)
Type LD	25 (34)
Type MD	25 (34)
Type ND	25 (34)
Type NB	25 (34)

- Step 8:** Remount the operating mechanism to the front of the power panel with the six bolts removed previously in Step 4.
- Step 9:** Position the power panel in the enclosure such that the two upper elongated holes, one on either side of the power panel, fit over the two positioning bolts located in the rear of the enclosure. This will line up the four correct mounting holes in the power panel with the pre-tapped inserts in the rear of the enclosure.
- Step 10:** With the power panel held securely against the back of the enclosure, replace and tighten the four mounting bolts removed previously in Step 3.
- Step 11:** If applicable, attach the neutral strap, removed in Step 2, to the back of the enclosure through the upper bonding hole.
- Step 12:** Reconnect the P1, P2, and P3 connector plugs that were disconnected in Step 1.

#### 4.5 Power Cable Connections

##### **! WARNING**

POWER CONDUCTORS MAY HAVE VOLTAGE PRESENT THAT CAN CAUSE SEVERE PERSONAL INJURY OR DEATH. DE-ENERGIZE ALL POWER OR CONTROL CIRCUIT CONDUCTORS TO BE CONNECTED TO THE ATS EQUIPMENT BEFORE BEGINNING TO WORK WITH THE CONDUCTORS AND/OR TERMINATING THEM TO THE EQUIPMENT.

##### **! CAUTION**

USE OF CABLE LUGS NOT DESIGNED FOR THE ATS MAY CAUSE HEATING PROBLEMS. BREAKER LUGS ONLY MOUNT TO THE BREAKER, WHILE TRANSFER SWITCH LUGS MOUNT TO BOTH THE BREAKER AND THE BUS BAR BEHIND THE BREAKER. FOR INSTALLATION INSTRUCTIONS, REFER TO THE INSTRUCTION LEAFLET SUPPLIED FOR THE SPECIFIC LUGS.

**! CAUTION**

TO HELP PREVENT COMPONENT DAMAGE OR FUTURE MALFUNCTIONS, USE EXTREME CARE TO KEEP CONTAMINANTS OUT OF THE ATS EQUIPMENT WHEN MAKING POWER CABLE CONNECTIONS.

**! CAUTION**

RUN THE POWER CABLE THROUGH THE GUTTER SPACE PROVIDED TO THE RIGHT OF POWER PANEL. DO NOT ROUTE THE POWER CABLES BEHIND OR TO THE LEFT OF THE POWER PANEL. RUNNING THE CABLES BEHIND OR TO THE LEFT OF THE POWER PANEL COULD INTERFERE WITH THE PROPER OPERATION OF THE TRANSFER SWITCH.

Test all power cables prior to connection to the unit to ensure that the conductors or cable insulation have not been damaged while being pulled into position.

Power cables are to be connected to solderless screw type lugs located on the ATS switching devices. Refer to the separate Customer Wiring Booklet supplied with the ATS equipment for power termination. Verify that the lugs supplied will accommodate the power cables being used. Also verify that the cables comply with local electrical codes. Standard ATS equipment, as supplied from the factory, will accommodate the wire sizes shown in Table 4.

Carefully strip the insulation from the power cables to avoid nicking or ringing of the conductor strands. Prepare the stripped conductor termination end by cleaning it with a wire brush. If aluminum conductors are used, apply an appropriate joint compound to the clean conductor surface area.

**! WARNING**

IMPROPER POWER CABLE CONNECTIONS CAN CAUSE EXCESSIVE HEAT AND SUBSEQUENT EQUIPMENT FAILURE.

Tighten the cable lugs to the torque identified on the label affixed to the door of the unit.

Table 4. Transfer Switch Equipment Wire Sizes

Transfer Switch Ampere Rating	Wire Size Ranges	Number of Cables per Phase	Terminal Temperature Rating °C (°F)
30-100	#14-3/0	1	75 (167)
150	#6-300KCMIL	1	75 (167)
225-300	#3-350KCMIL	1	75 (167)
400	#3-350KCMIL	2	75 (167)
600 (3P)	#1-500KCMIL	2	75 (167)
600 (4P)	3/0-400KCMIL	3	75 (167)
800-1200	3/0-500KCMIL	4	75 (167)

4.6 Wiring

**! WARNING**

POWER CONDUCTORS AND CONTROL WIRING MAY HAVE VOLTAGE PRESENT THAT CAN CAUSE SEVERE PERSONAL INJURY OR DEATH. DEENERGIZE ALL POWER OR CONTROL CIRCUIT CONDUCTORS BEFORE BEGINNING TO PERFORM ANY WIRING ACTIVITY TO OR WITHIN THE ATS EQUIPMENT.

Power sources, load conductors, and control wiring should be connected to locations as indicated in the Customer Wiring Booklet supplied with the ATS equipment.

**! CAUTION**

ENSURE THE ATS VOLTAGE IS SET CORRECTLY. IT SHOULD BE THE SAME AS THE SOURCE 1 AND SOURCE 2 LINE VOLTAGES. OPERATING THE EQUIPMENT ON IMPROPER VOLTAGE CAN CAUSE EQUIPMENT DAMAGE.

Once the ATS equipment has been installed and wired, perform the initial mechanical and electrical procedures as outlined in Section 6 to verify that the equipment is installed and operating properly.

**NOTICE**

REMEMBER TO REATTACH THE SOLID STEEL POWER PANEL SHIELD TO THE RATCHET ASSEMBLY AFTER COMPLETING ANY OF THE PROCEDURES DESCRIBED IN THIS SECTION.

**4.7 Engine Start Connection**

The engine control contact connections are located on the logic panel of the ATS. Connect the engine start wires to the terminals marked 13 and 14 on J-5 connector on the ATC-300 Controller (see Figure 24). A contact closes between these terminal when an engine start signal is provided by the ATS logic. The wiring diagram provides additional engine start connection information. Use the proper wire size as listed by the generator set (Genset) manufacturer.

**NOTICE**

**PRIOR TO MAKING THE ENGINE START CONNECTION TO THE SWITCH, SET THE ENGINE GENERATOR CONTROLS SELECTOR SWITCH IN THE OFF POSITION TO PREVENT AN UNWANTED ENGINE START. IT IS RECOMMENDED THAT CONTROL WIRING, SUCH AS THE ENGINE START WIRES, BE RUN IN A SEPARATE CONDUIT FROM THE POWER CABLES.**

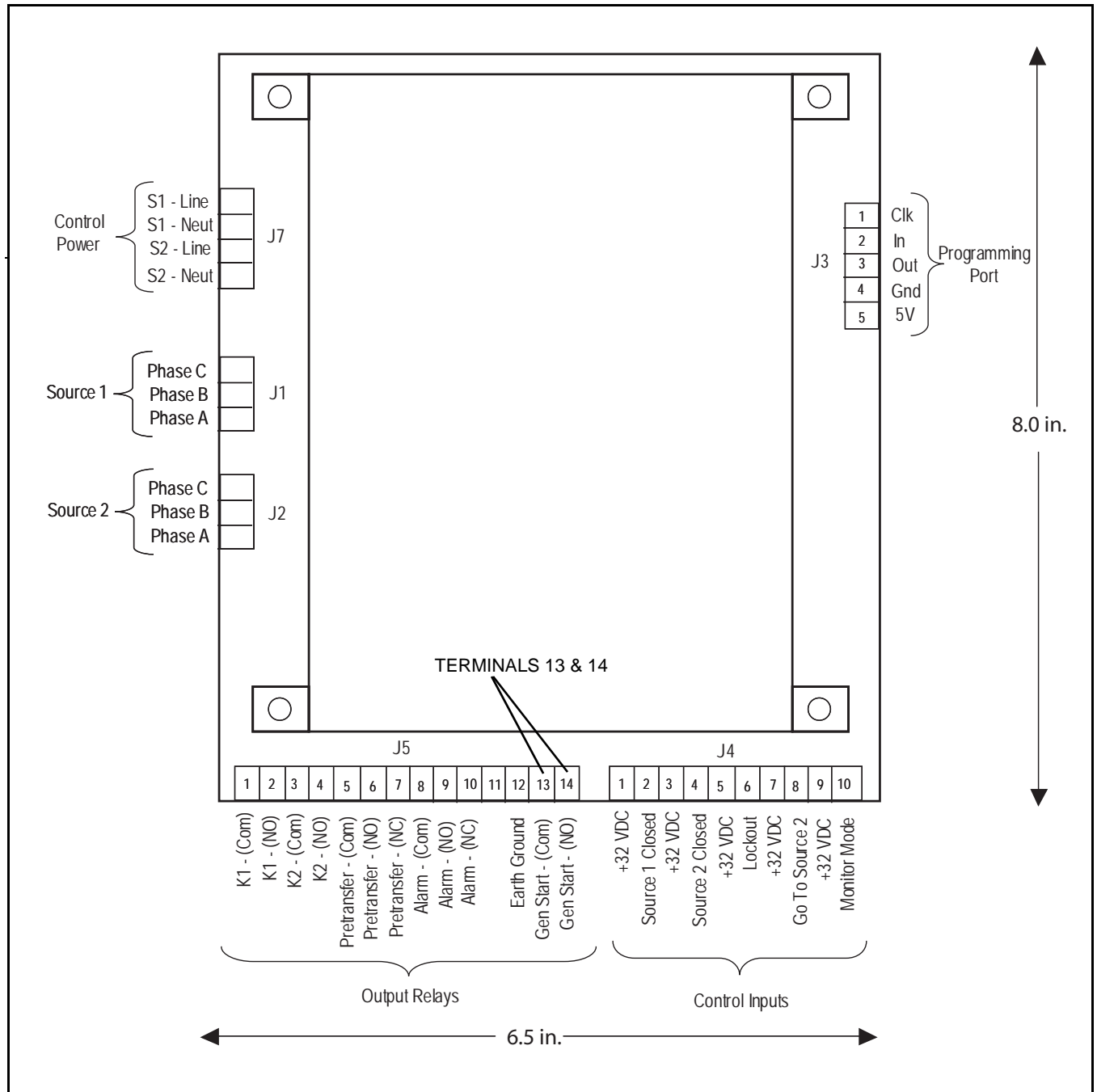

**Figure 24. Location of Terminals 13 and 14 on the J-5 Connector.**

## 4.8 Voltage Selection Adjustments

Certain devices, such as the Voltage Selection Panel, sensing relays, and timers, need to be set and/or calibrated prior to placing the ATS equipment in service. Adjustments for logic devices are described in the separate instructional document dedicated to the specific logic being used. Voltage selection adjustments are described in this section.

### CAUTION

**BE SURE THAT THE CORRECT VOLTAGE IS SELECTED TO MATCH THE SYSTEM VOLTAGE. AN IMPROPER SELECTION AND/OR CONNECTION COULD RESULT IN EQUIPMENT DAMAGE.**

#### 4.8.1 North American Market Voltage Selection Panels (120, 208, 240, 480, and 600 V, - 60 Hz)

##### Vertical and Horizontal Design Voltage Selection

The North American market Voltage Selection Panel consists of multi-tap transformers, contained in a steel case mounted in the enclosure. The cover has “teardrop” holes for the screws to allow easy access to the transformers. To change the voltage from the factory default 600 Vac, follow the steps detailed below.

- Step 1:** Loosen the four screws securing the cover of the Voltage Selection Transformer case. Slide the cover up, then away from the case.
- Step 2:** Remove the wires from the primary taps of both transformers and installed them on the taps for the desired voltage (Figure 25). Note that only one wire per transformer is moved since the second wire is the zero reference.

### CAUTION

**WHEN CHANGING THE VOLTAGE, ONE WIRE MUST BE MOVED ON THE PRIMARY TAPS OF BOTH TRANSFORMERS.**

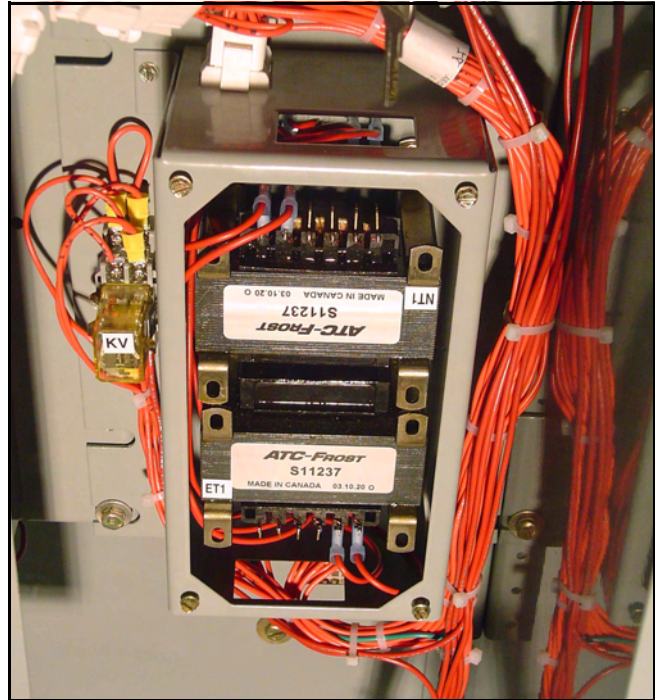

**Figure 25. North American Market Voltage Selection Panel with Voltage Being Selected.**

**Step 3:** Reinstall the cover and tighten the four screws.

#### 4.8.2 International Market Power Panels (208, 220, 240, 380, 415, and 600 V - 50-60 Hz)

##### Vertical Design Voltage Selection

The vertical design transfer switch is furnished with a multi-tap Voltage Selection Panel to the right of the power panel. Seven front accessible taps from 208 to 600 Vac are provided (Figure 26). A small disconnect plug is provided to change from one voltage to another. The transfer switch is shipped with the plug in the 600 Vac position.

##### Horizontal Design Voltage Selection

Horizontal design transfer switches are furnished with an adjustable line voltage plug and receptacles below the power panel. To change the line voltage, insert the plug in the desired receptacle (Figure 26). The transfer switch is shipped with the plug in the 600 Vac position.

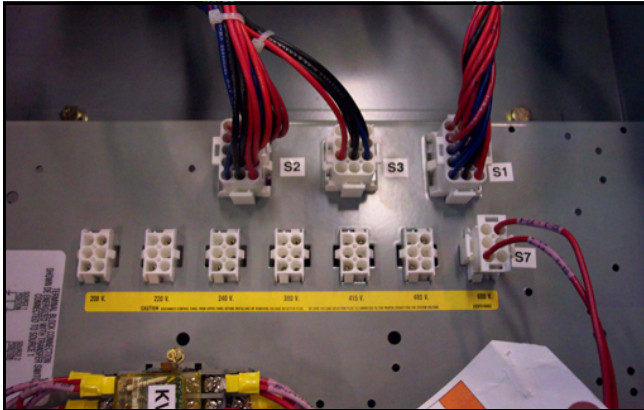
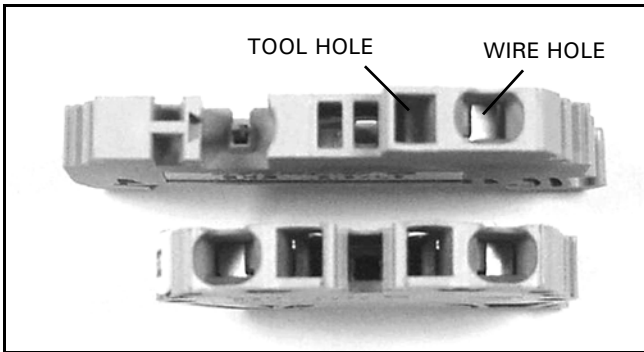

**Figure 26. Line Voltage Plug and Receptacles for Horizontal Design.**

**4.9 Terminal Block Wire Installation and Removal**

Proceed with the following steps and associated figures to install or remove terminal block wiring.

**Step 1:** Figure 27 shows two tension clamp terminal blocks. There is a large one and small one, but the operation is the same for both. A small tool, such as a screwdriver, will be pushed into the square hole next to the wire hole and a wire will be inserted into the larger circular hole on the outer edge.



**Figure 27. Tension Clamp Terminal Blocks.**

**Step 2:** Begin by inserting a small, flathead screwdriver into the square (tool) hole with the flat surface of the screwdriver against the back wall of the hole. With a little bit of force, push the screwdriver in on a slight angle toward the center of the clamp. Be sure to slide it in until it clicks. You will then see the clamp open in the wire hole.

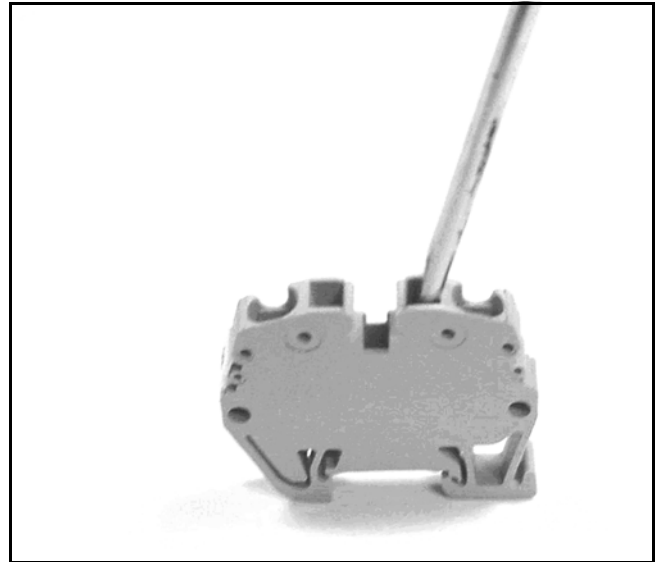

**Figure 28. Screwdriver Inserted in the "Tool" Hole.**

**Step 3:** Once the screwdriver is in place, obtain a stripped wire (strip about 1/4 in.) and insert it into the larger circular wire hole. Push the wire in until it can go no further.

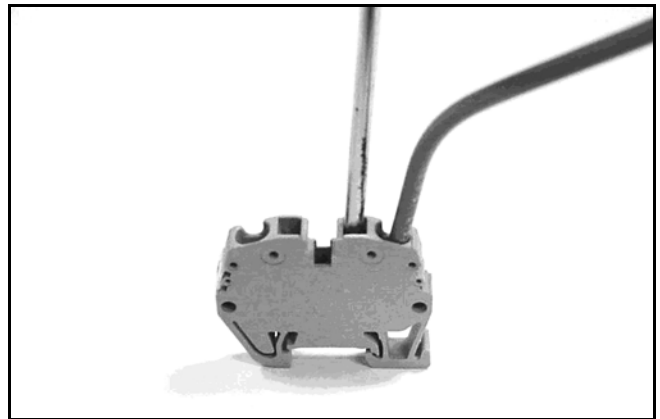

**Figure 29. Wire Inserted in the "Wire" Hole.**

**Step 4:** While holding the wire in place, pull the screwdriver out. The wire will now be held securely in the terminal block. Pull on the wire to insure that it is correctly inserted into the clamp.

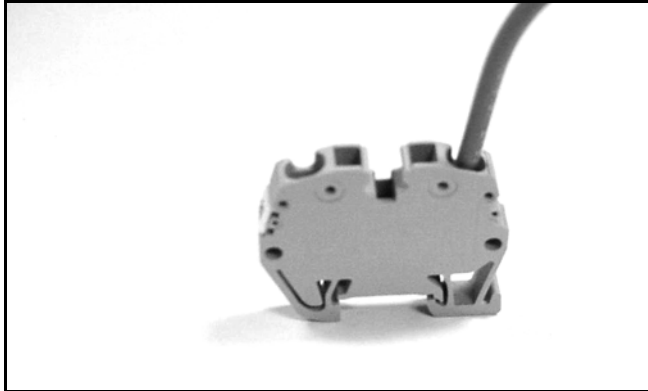

Figure 30. Wired Securely Installed in the Terminal Block.

## SECTION 5: OPERATION

### 5.1 General

An ATS provides main contacts to connect and disconnect the load to and from the Source 1 and Source 2 power sources (Section 3.2.2). Each transfer mechanism provides the mechanical motion required to open and close the mechanically interlocked main contacts (Section 3.2.3).

Note that the transfer mechanisms for the two types of ATSs described in this booklet (30-150 A and 225-1200 A) are different for both the manual and automatic modes.

### NOTICE

**IF AN ATS WITH ANY TYPE OF ELECTRICAL OPERATING CAPABILITIES IS TO BE OPERATED UTILIZING THE MANUAL OPERATING HANDLE, IT IS STRONGLY RECOMMENDED THAT THE TRANSFER MOTOR CIRCUIT FIRST BE ISOLATED. THIS IS ACCOMPLISHED BY UNPLUGGING THE (P3) PLUG MARKED MOTOR DISCONNECT (FIGURE 31). ANY ATTEMPT TO USE THE MANUAL OPERATING HANDLE WITHOUT FIRST ISOLATING THE MOTOR CIRCUIT CAUSES AN AUTOMATIC TRANSFER.**

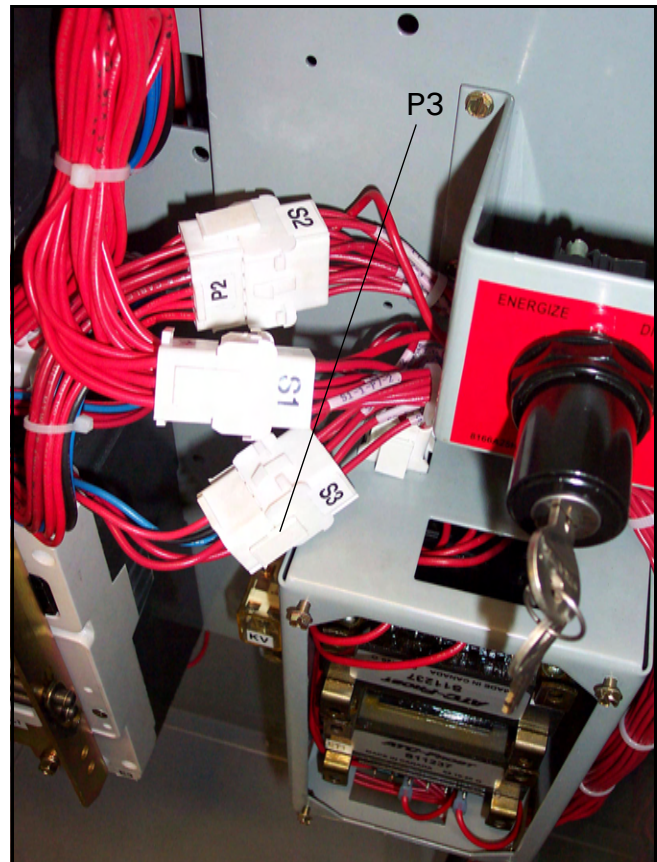

Figure 31. Motor Disconnect P3 must be disconnected.

### 5.2 Manual Operation (225-1200 A)

The manual operating handle can be used to create the rotational motion required to open and close the main contacts through a rigid mechanical interlocking system (Figure 32).

An indicator wheel attached to the operating handle and mechanical interlocking system rotates with each movement of the handle to open and/or close the main contacts (Figures 33). Three distinct switch positions are provided and indicated visually on the indicator wheel (Figure 34).



Figure 32. ATS Manual Operating Handle in Use (225-1200 A Models).

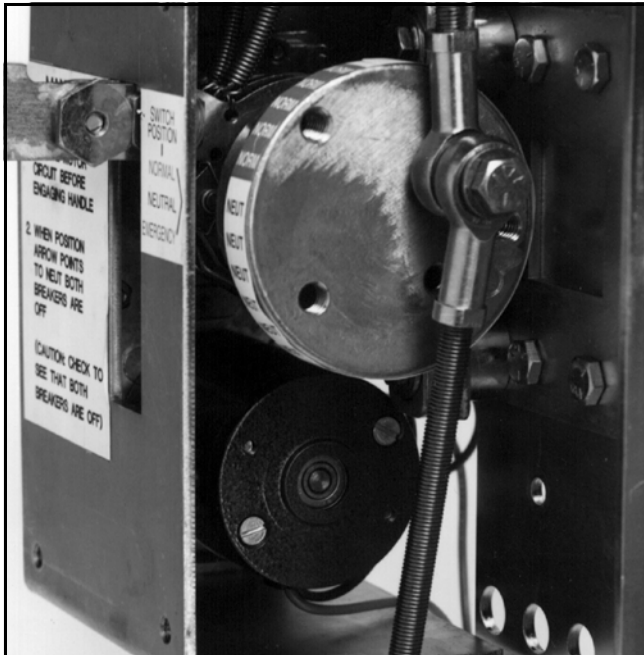

Figure 33. Indicator Wheel Mounted in the Switch with Motor Under the Wheel (225-1200 A Models).

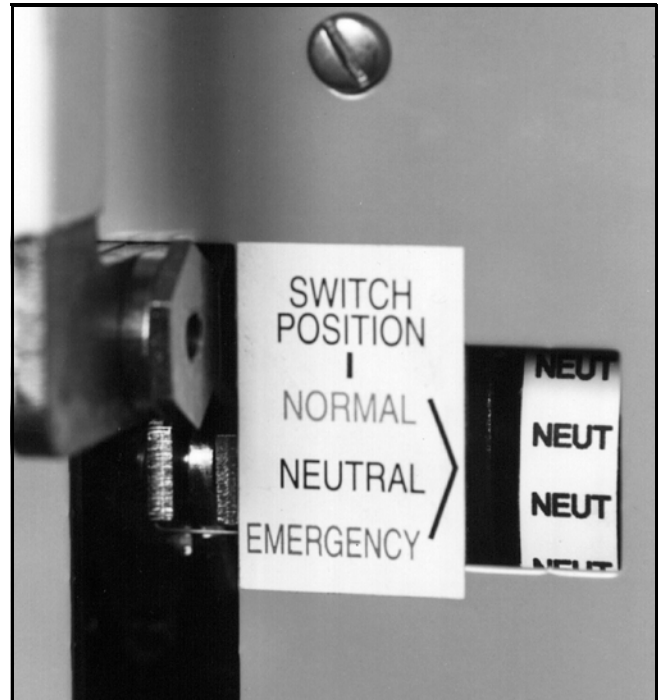

Figure 34. Indicator Wheel in Neutral Position (225-1200 A Models).

The three distinct switch positions or contact conditions are:

**Source 1:** The contacts associated with the Source 1 power source are closed and the Source 2 power source contacts are open.

**Neutral:** The contacts associated with both the Source 1 and Source 2 power sources are open. This position allows for load circuit maintenance.

**Source 2:** The contacts associated with the Source 1 power source are open and the Source 2 power source contacts are closed.

To manually operate the ATS, the manual operating handle is ratcheted until the desired switch position is indicated on the indicator wheel. The operating handle, no matter what design or type of switch operation, is always electrically "dead" and the indicator wheel free-wheels should a particular switch have a motor and be capable of electrical operation. This feature ensures no operator problems should the switch automatically operate while the manual handle is being used.

### 5.3 Manual Operation (30 - 150 A)

To operate the breaker manually, or if the breaker trips, unplug P3 from S3 to disconnect the motor circuit (Figure 35). Turn and hold the break release lever to "HOLD FOR MANUAL OPERATION" position, and then rotate the manual operator knob in either direction to move the ATS into the desired position. Let go of the brake release lever for "AUTOMATIC OPERATION" after P3 and S3 are reconnected.

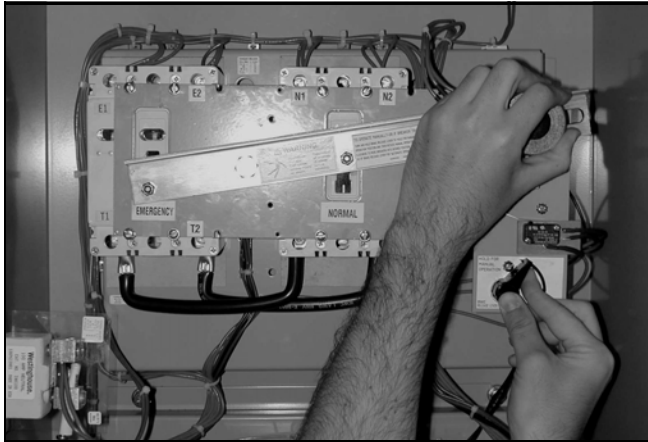

**Figure 35. Switch Being Manually Operated (30-150 A Model).**

4. Simultaneously, the engine cool-down timer initiates the shut down of the engine driven generator.
5. Transfer of the load back to the Source 1 power source is now complete.

## 5.4 Automatic Transfer

The operating sequence of an ATS is dictated by the switch's standard features and selected options. Operation of an ATS during Source 1 power source failure and Source 1 power source restoration will be described here with only standard options included on the switch. Additional options, as described in Section 3, can change sequences and timing, depending upon the options selected. It is strongly suggested that you become familiar with additional options selected with the particular ATS and their effect on the normal operation of an ATS.

### 5.4.1 Source 1 Power Source Failure

Standard Source 1 power source failure is defined as a reduction or loss of voltage. If this occurs, the sequence of operation is as follows.

1. Failure of Source 1 is detected by the controller intelligence.
2. When the controller detects a failure, the engine contacts close (after delay if programmed) and start the engine-driven generator.
3. When the Source 2 voltage reaches its operation rating, the K2 relay closes, starting the transfer operation. This operating sequence opens the Source 1 switch and closes the Source 2 switch.
4. The load is now transferred to the Source 2 power source.

### 5.4.2 Source 1 Power Source Restoration

1. A return to the Source 1 power source begins when the voltage in all phases of a three-phase sensing unit, or phase-to-phase in a single sensing unit, is restored to a preset value.
2. At the present voltage, the controller will cause the K1 relay to change state. This starts the return to the Source 1 power source and Source 1 transfer switch operation.
3. During this sequence, the Source 2 power source switch is opened and the Source 1 power source switch is closed.

## SECTION 6: TESTING AND PROBLEM SOLVING

### 6.1 Testing

After the ATS equipment is initially installed or during planned outages, the installation should be tested to ensure that all equipment operates properly. This attention to detail will help avoid unexpected malfunctions. Mechanical and/or electrical tests should be performed as described in this section.

The frequency of subsequent testing should be based on recommendations of the Genset manufacturer. Use the test pushbutton to check the electrical operation of the switch.



### WARNING

HIGH VOLTAGES ASSOCIATED WITH OPERATIONAL TRANSFER SWITCH EQUIPMENT PRESENT A SHOCK HAZARD THAT CAN CAUSE SEVERE PERSONAL INJURY OR DEATH. USE EXTREME CAUTION TO AVOID TOUCHING ELECTRICAL CONNECTIONS WHENEVER INSPECTING OR TESTING THE EQUIPMENT.

IN ADDITION, IMPROPER OPERATION OF THE GENERATOR SET PRESENTS A HAZARD THAT CAN CAUSE SEVERE PERSONAL INJURY OR DEATH. OBSERVE ALL SAFETY PRECAUTIONS IN YOUR GENERATOR SET OPERATIONS AND INSTALLATION MANUALS.

#### 6.1.1 Mechanical and/or Electrical Testing

### NOTICE

SINCE FEATURE 4 (TIME DELAY ENGINE COOL-OFF), AS DESCRIBED IN SECTION 3, IS A STANDARD FEATURE, AN ENGINE START SIGNAL WILL BE PRESENT FOR A PERIOD OF TIME WHEN THE SWITCH IS FIRST ENERGIZED. THE PERIOD OF TIME IS EQUAL TO THE TIMER SETTING. TO AVOID STARTING THE ENGINE DURING THIS TIME PERIOD, TURN THE GENERATOR CONTROLS TO THE OFF POSITION.

Energize the ATS equipment as described in Sections 6.1.2 through 6.1.6. Insure that all safety precautions are taken and that all **WARNINGS** and **CAUTIONS** are observed.

#### 6.1.2 No Voltage Steps

With no voltage available on either power source, proceed as follows.

- Step 1:** Check to make sure that both the Source 1 and Source 2 power switching devices are in the OPEN position. The switching devices can be put into the OPEN position using of the manual operating handle, stopping in the NEUTRAL position.
- Step 2:** The generator engine start controls should be in the OFF position to prevent an undesired start.
- Step 3:** Ensure that the ATS has been set to the proper applied system voltage (See Section 4.8).
- Step 4:** Check all ATS loads to ensure that they are ready to be energized.

#### 6.1.3 Connecting the Power Sources

- Step 1:** Close the Source 1 power source upstream protection device. The Source 1 power switching device should close

- Step 2:** Connect the engine start battery cable.

- Step 3:** With the emergency generator in the OFF position, close the Source 2 power source upstream protective device, assuming such a device used.

### NOTICE

AT THIS POINT, AND PRIOR TO MAKING ANY ATTEMPT TO ENERGIZE THE ATS EQUIPMENT, THE ENGINE-DRIVEN GENERATOR SHOULD BE OPERATED. IF NECESSARY, THE VOLTAGE REGULATOR ON THE GENERATOR SHOULD BE ADJUSTED ACCORDING TO THE MANUFACTURER'S RECOMMENDATIONS. THE ATS EQUIPMENT WILL RESPOND ONLY TO THE RATED VOLTAGE AND FREQUENCY PROGRAMMED INTO THE CONTROLLER.

- Step 4:** Close any generator engine-start controls opened as a result of actions taken in Step 4, Section 6.1.2.

- Step 5:** Where required, use an accurate voltmeter to check phase-to-phase and phase-to-neutral voltages present at the transfer switch Source 1, Source 2, and/or load terminals.

#### 6.1.4 Operational Checks

- Step 1:** Check to ensure that the Source 1 switching device is in the CLOSED position. This should have been done in Section 6.1.3, Step 1.

- Step 2:** Initiate an automatic transfer operation from the Source 1 to the Source 2 power source by pressing the **<Engine Test>** pushbutton two times.

**Note:**The ATC-300 Logic Controller provides the capability to set the Engine Test function to:

1. No Load Engine Test;
2. Load Engine Test; or
3. Disabled.

The factory default is set to:

1. Load Engine Test
  - a. After the Time Delay Engine Starting (TDES) has timed out, the engine should start, run, and build up to normal voltage and frequency.
  - b. The transfer switch will transfer to the Source 2 power source (the Source 1 switching device opens and Source 2 switching device closes) after the Time Delay Normal to Emergency (TDNE) times out.

- Step 3:** Initiate an automatic transfer operation back to the Source 1 power source by pressing the **<Engine Test>** pushbutton one time.

1. After the Time Delay Emergency to Normal timer (TDEN) has timed out, the transfer switch will transfer back to the Source 1 power source (the Source 2 switching device opens and the Source 1 switching device closes).
2. The Time Delay for Engine Cool-Off (TDEC - Feature 4) will allow the engine to run unloaded for a preset time after transfer to the Source 1 power source is completed.

**6.1.5 Alternate Tests**

1. Alternate operational tests may be possible depending upon the options provided with any given ATS. Refer to the schematic diagram provided with the ATS equipment, along with the specification nameplate, to determine the exact options provided.
2. If you attempt to manually operate the ATS with the Source 1 power source connected and available, the ATC-300 logic will cycle the ATS back to the Source 1 power source since it is the preferred source. The ATS was designed with this safety feature in case a manual transfer is attempted while the switch is in automatic mode and under load.

**6.2 Problem Solving**

---

 **WARNING**

---

**HAZARDOUS VOLTAGES IN AND AROUND ATS EQUIPMENT DURING THE PROBLEM SOLVING PROCESS CAN CAUSE SEVERE PERSONAL INJURY AND/OR DEATH. AVOID CONTACT WITH ANY VOLTAGE SOURCE WHILE PROBLEM SOLVING.**

---



---

 **WARNING**

---

**ONLY PROPERLY TRAINED PERSONNEL, FAMILIAR WITH THE ATS EQUIPMENT AND ITS ASSOCIATED EQUIPMENT, SHOULD BE PERMITTED TO PERFORM THE PROBLEM SOLVING FUNCTION. IF AN INDIVIDUAL IS NOT QUALIFIED TO PERFORM THE PROBLEM SOLVING FUNCTION, THE INDIVIDUAL SHOULD NOT ATTEMPT ANY OF THESE PROCEDURES.**

---

A basic problem-solving effort is the first step to take prior to calling for assistance. Frequently, the effort will successfully address most problems encountered. The problem solving procedure is presented in the Troubleshooting Guide. Remember, only qualified individuals familiar with the ATS equipment and the system in which it is applied should attempt these problem solving procedures.

If a problem persists after having completed the problem solving procedure, contact a Eaton representative for further assistance. When calling for assistance, the following is the minimum information required to properly address the need:

1. Style number of ATS, if applicable;
2. Catalog number of ATS;
3. Actual location of the ATS (type of facility, address, etc.);
4. Company name and name and position of individual representing company;
5. Basic description of the situation as it exists; and
6. Any results of the problem solving steps taken and/or readings taken.

**SECTION 7: ADJUSTMENTS****7.1 General**

Refer to I.B. 01602009E, supplied with the ATS for ATC-300 Controller adjustments and programming.

## SECTION 8: MAINTENANCE

### 8.1 Introduction

 **WARNING**

**HIGH VOLTAGES ARE PRESENT IN AND AROUND ATS EQUIPMENT. BEFORE INSPECTING OR MAINTAINING THIS EQUIPMENT, DISCONNECT THE LINE POWER FROM, THEN LOCK OUT, IF POSSIBLE, THE NEXT HIGHEST DISCONNECT DEVICE. FAILURE TO FOLLOW THIS PROCEDURE COULD CAUSE SEVERE PERSONAL INJURY AND/OR DEATH.**

In general, ATS switch equipment is designed to be relatively maintenance free under normal usage. However, because of the variability of application conditions and the importance placed on dependable operation by this type of equipment, inspection and maintenance checks should be made on a regularly scheduled basis. Since equipment maintenance will consist mainly of keeping the equipment clean, the frequency of maintenance will depend to a large extent on the cleanliness of the equipment's surroundings. If a significant amount of dust or foreign matter is present, a more frequent maintenance schedule should be followed.

It is suggested that visual inspections of the equipment be made on a regular basis, not just during scheduled periods. Always be alert for an accumulation of dirt in and around the structure; loose parts; and/or hardware, cracks, and/or discoloration to insulation; and damaged or discolored components.

### 8.2 Procedures

A suggested maintenance procedure is outlined in Table 5.

**Table 5. Periodic Maintenance Procedures**

Step	Action
a. Make the ATS equipment safe for inspection and/or maintenance.	Disconnect the line power from equipment being serviced by opening the next highest disconnect device. Make certain that any accessory control power is switched off by disconnecting all control plugs.
b. Inspect the structure area for safety hazards or potential maintenance problems.	Inspect the area, especially where molded case switching devices are installed, for any safety hazards, including personnel safety and fire hazards. Exposure to certain chemical vapors can cause deterioration of electrical connections.  Inspect for accumulated dirt, loose hardware, or physical damage.  Examine the primary insulation for evidence of cracking or overheating. Overheating will show as discoloration, melting, or blistering of conductor insulation, or as pitting or melting of conductor surfaces due to arcing.  Inspect the secondary control connections for damage and the control wiring for insulation integrity.
c. Inspect the molded case switching devices for dust, dirt, soot, grease, moisture, or corrosion.	Remove dust, dirt, soot, grease, moisture, and corrosion contamination from the surface of the switching device using a dry soft lint-free cloth, dry soft bristle brush, and vacuum cleaner. Do not blow debris into the circuit breaker or nearby breaker structure. If contamination is found, look for the source and fix the problem.
d. Check for material integrity, uneven wear, discoloration, or loose hardware.	Severe material cracking will require replacement and loose hardware will need to be tightened.
e. Check the terminals and connectors for looseness or signs of overheating.	Overheating will show as discoloration, melting, or blistering of the conductor insulation.  Connections that do not have signs of looseness or overheating should not be disturbed.
f. Exercise the molded case switching devices if they are not often exercised while in operation. This will permit a "wiping" action by the contacts.	If a switching device is used for frequent switching during normal operation, this step can be disregarded.
g. Return the ATS equipment to service.	Make certain all barriers are in place and doors closed. Reapply secondary and primary power.

**SECTION 9: RENEWAL PARTS GUIDE**

**9.1 General**

Refer to Figure 36A and B for assistance with selecting and ordering selected ATS renewal parts.

**Example:** To order the transformer panel for an **ATH3FDA30150XSU** transfer switch, order Catalog Number **TSTPH** as shown in Figures 36A and B.

COMPLETE POWER PANEL - PLEASE NOTE THE ORIGINAL CATALOG NUMBER OF TRANSFER SWITCH, AS IT IS REQUIRED TO COMPLETE THE CATALOG NUMBER OF A POWER PANEL.

EXAMPLE: ATV3KDA30300WSU  
ATH3FDB20200BSU

VERTICAL POWER PANEL CAT#: PPV3KDA30300XKU

NOTE THAT THE SECOND TO THE LAST CHARACTER WILL ALWAYS BE A "K" WHEN ORDERING A REPLACEMENT POWER PANEL.

HORIZONTAL POWER PANEL CAT#: PPH3FDB20200BKU (NOT SHOWN)

CAT#: TSMBB

Figure 36A. Typical ATC-300 Controlled ATS.

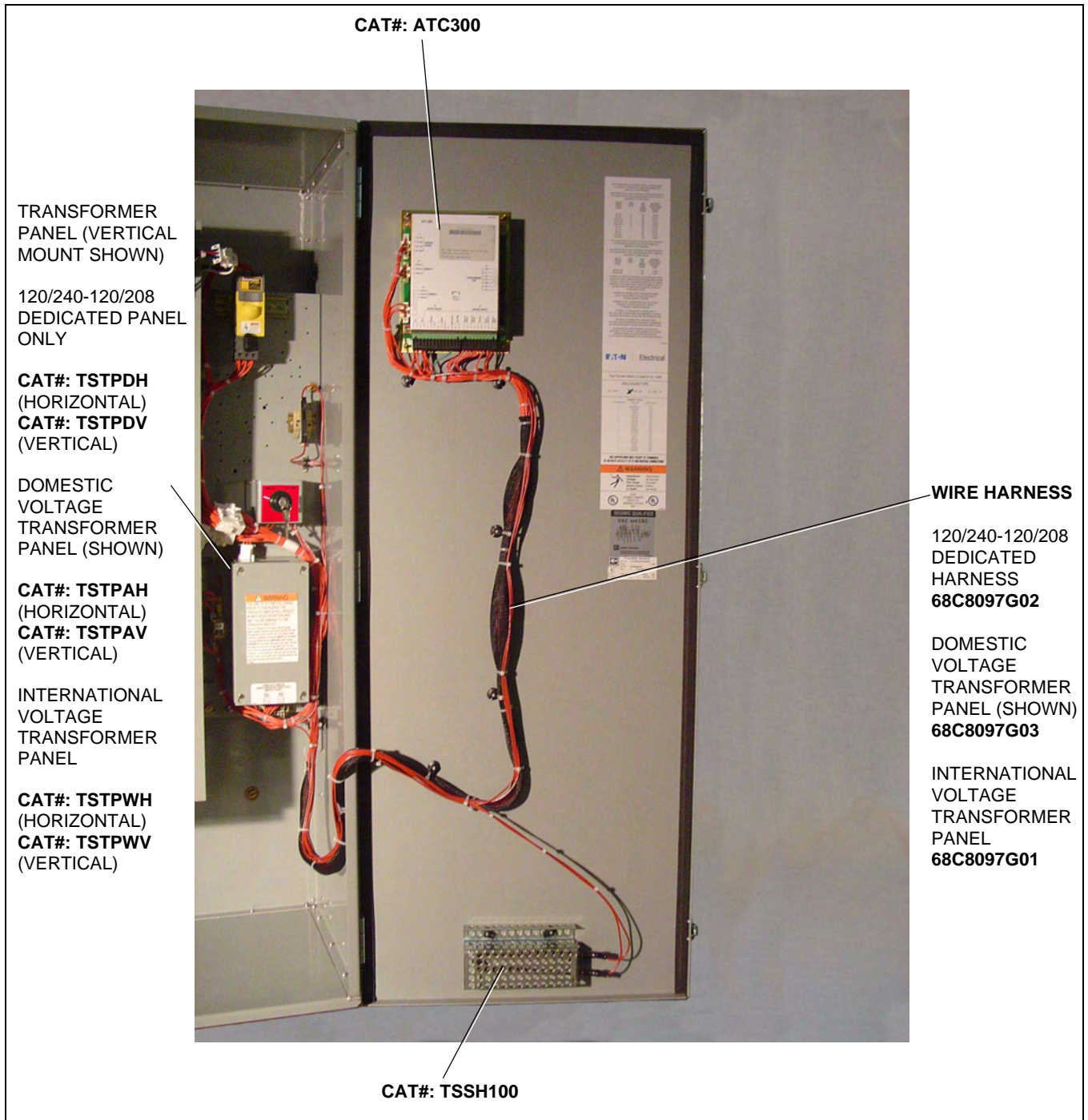

Figure 36B. Typical ATC-300 Controlled ATS.

## SECTION 10: ATC-300 CONTROLLED ATS QUICK START INSTRUCTIONS

**WARNING**

THESE QUICK START INSTRUCTIONS ARE NOT A COMPLETE SOURCE OF INFORMATION ON THE ATC-300 CONTROLLED ATS EQUIPMENT. INSTALLATION SHOULD NOT BE STARTED UNTIL THE ENTIRE INSTRUCTION BOOK HAS BEEN REVIEWED AND UNDERSTOOD. FAILURE TO FOLLOW THE FULL INSTRUCTIONS CAN RESULT IN DEATH, SEVERE PERSONAL INJURY, OR PROPERTY DAMAGE.

**WARNING**

THESE QUICK START INSTRUCTIONS ARE PROVIDED FOR USE ONLY BY TECHNICIANS HIGHLY FAMILIAR AND EXPERIENCED WITH ATC-300 CONTROLLED ATS EQUIPMENT INSTALLATION, SET UP, AND TESTING. IT IS STRONGLY SUGGESTED THAT THE FULL INSTRUCTIONS BE FOLLOWED FOR ALL INSTALLATIONS, SET UP, AND TESTING.

**Step 1:** Mount the ATS on a flat rigid surface (Figure 37). Shim if necessary. For seismic mounting requirements, check the main instruction sections of this manual.

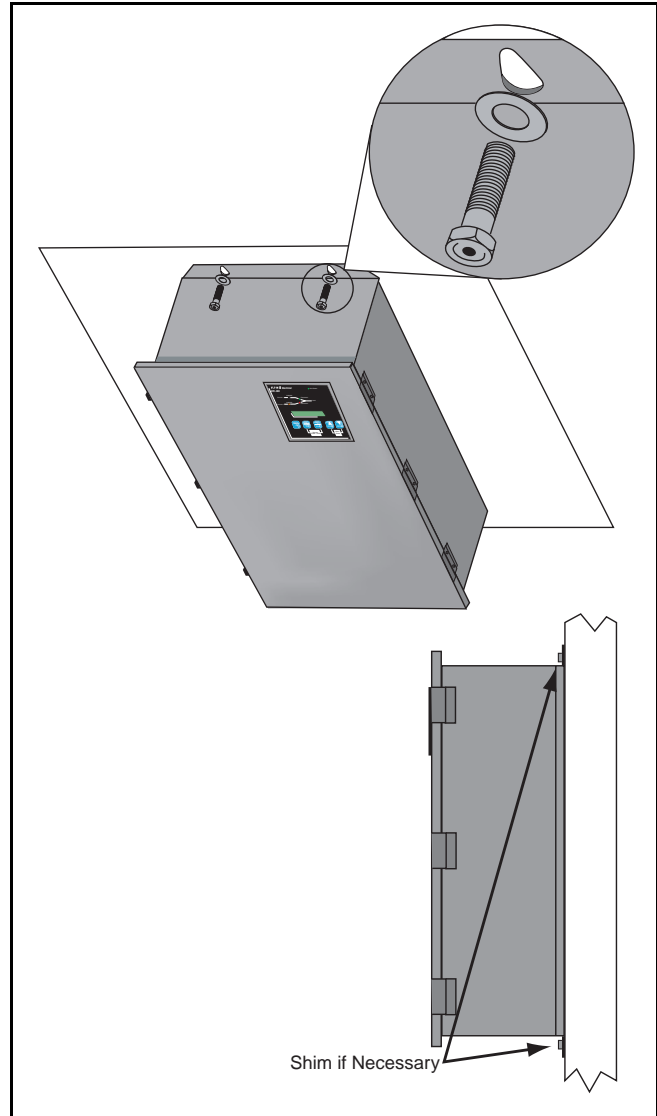

**Figure 37. Mounting Details**

**Step 2:** Install the power cables. Cables must be sized and installed per National Electrical Code, refer to NFPA70. The cables must be sized within the specified cable size range on the side of the cable connectors.

Connect the cables and torque to the correct value indicated on the label near the lugs in the following order:

1. Load Cables\* (T1, T2, T3);
2. Source 1 or Utility Supply (N1, N2, N3); and
3. Source 2 or Generator Supply (E1, E2, E3).

For 4 pole transfer switches, connect the load cables (TN), Source 1 or utility supply (NN), and Source 2 or generator supply (EN). Refer to Figure 38 for the location of all parts discussed in this document.

\* Load cables on switches using the vertical design MUST be connected and torqued BEFORE installing the SUPPLY cables (Figures 38 and 39).

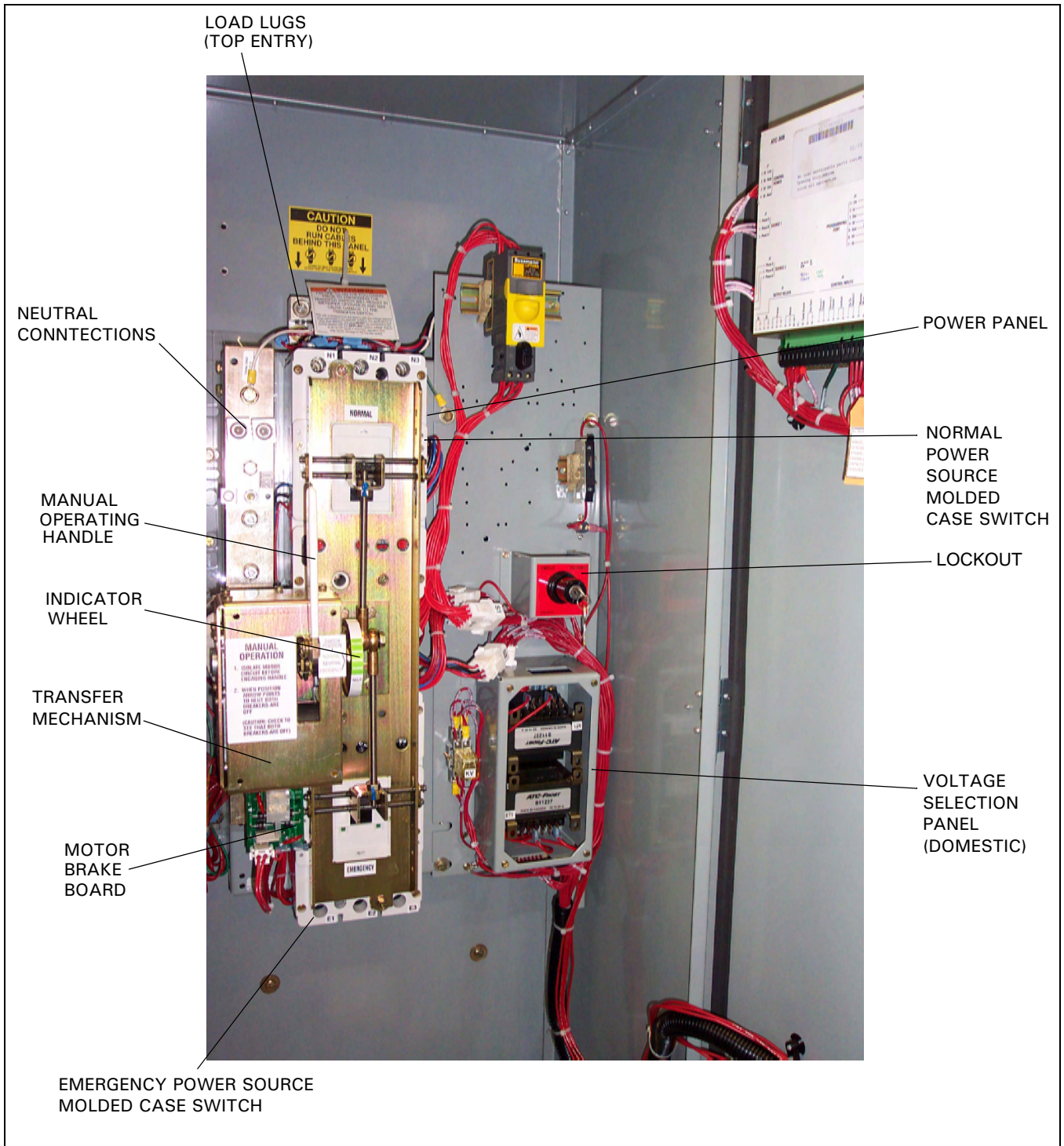

Figure 38. 300 A, 3-Pole, ATS Interior Components.

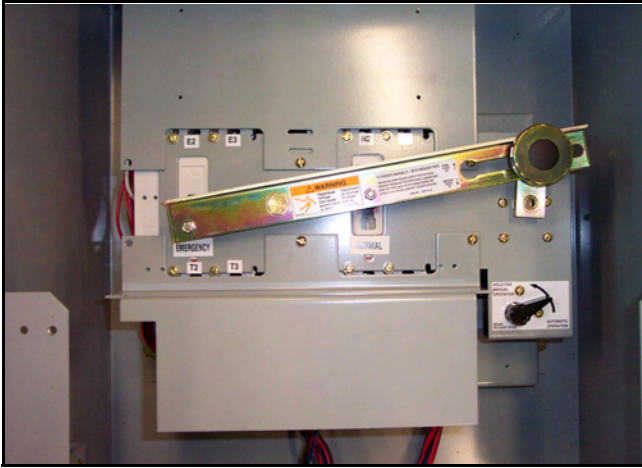
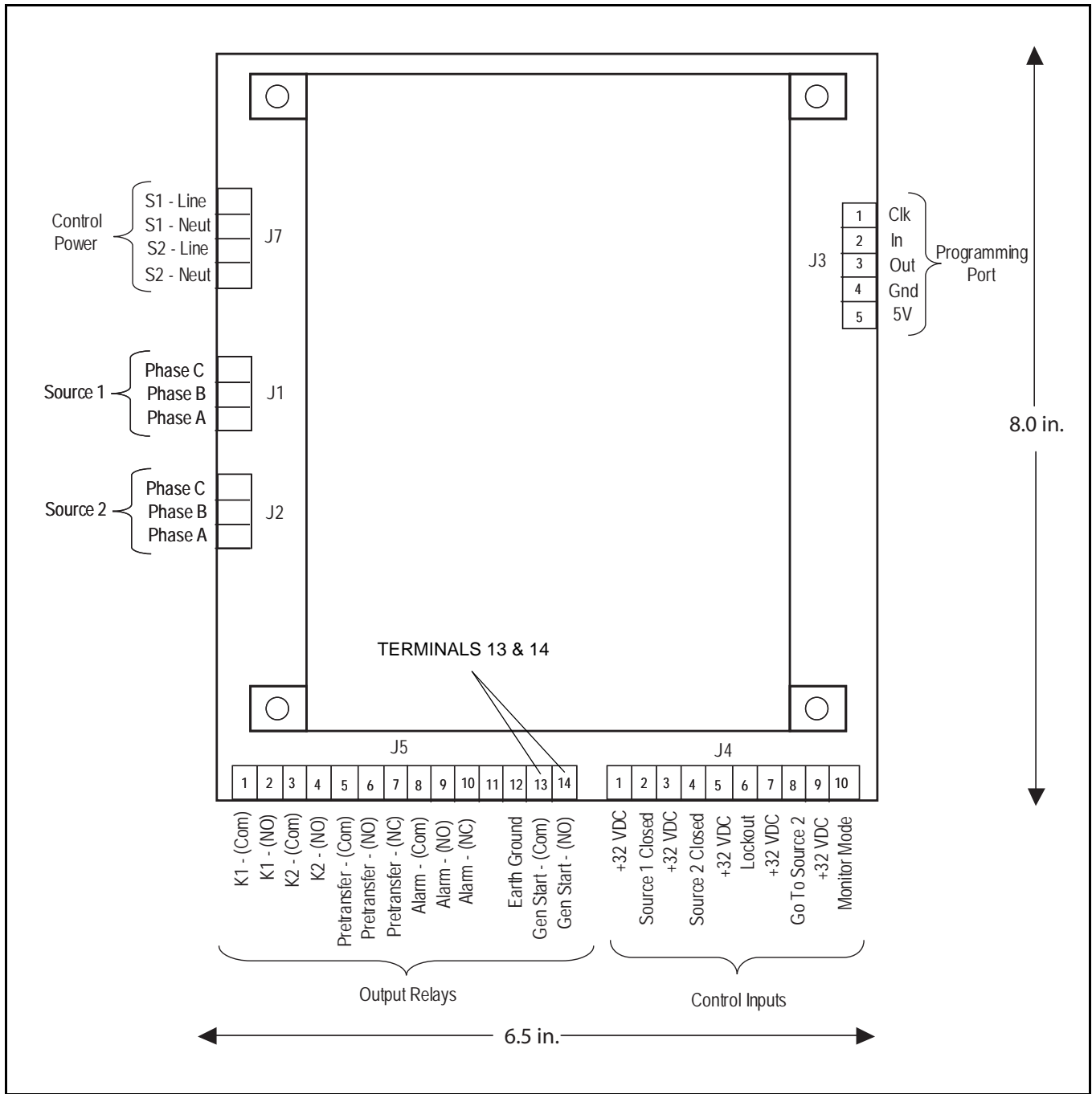

Figure 39. Horizontal Power Panel

- Step 3:** Turn the generator OFF at the generator control panel. This will prevent unexpected activation of the generator.
- Step 4:** Connect the Engine Generator Start wires to terminals 13 and 14 on the J-5 connector on the ATC-300 Controller (Figure 40). This contact is CLOSED whenever the engine generator is needed, and should be connected to a generator controller. **NEVER** connect directly to a starter solenoid or ignition system. See the Genset manufacturer instruction leaflet for recommended wire sizes and location procedures.
- Step 5:** Apply Utility (Source 1) power. If the switch is properly applied for the system voltage ordered, the display should work and the Source 1 Available white LED should light (Figure 41). Using a voltmeter, check for proper system voltage on Source 1 and load terminals. Check all phases on a 3-phase switch. Voltage measurements should be taken phase to phase and phase to neutral.



**Figure 40. Engine Generator Control Connection**

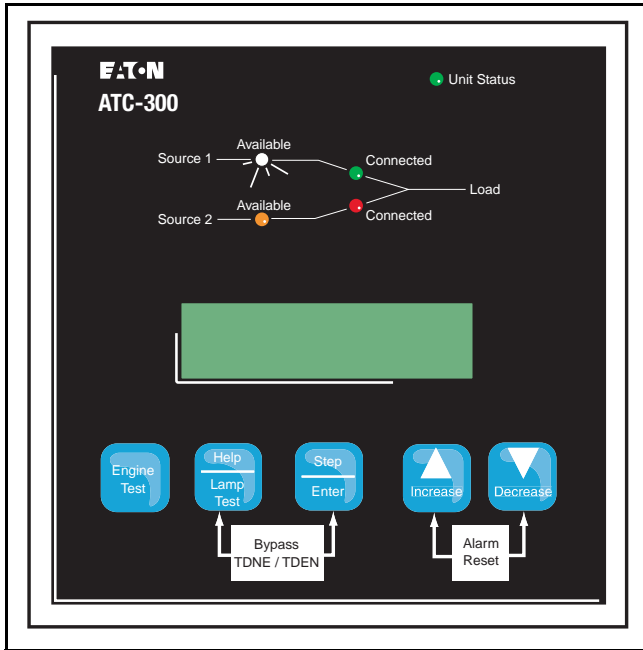

Figure 41. ATC-300 Logic (Utility Supplying Load)

**Step 6:** To view the setpoints, press the <Step/Enter> pushbutton and enter the Password.

**Note:** The factory default Password is 0300. Once all installation and testing is complete, the Password should be changed by authorized personnel to a unique Password for the equipment.

After entering the password, press the <Step/Enter> pushbutton until the VIEW SETPOINTS menu appears. Select YES. Press the <Step/Enter> pushbutton to scroll through the setpoints (Figures 42 through 44 and Table 6).

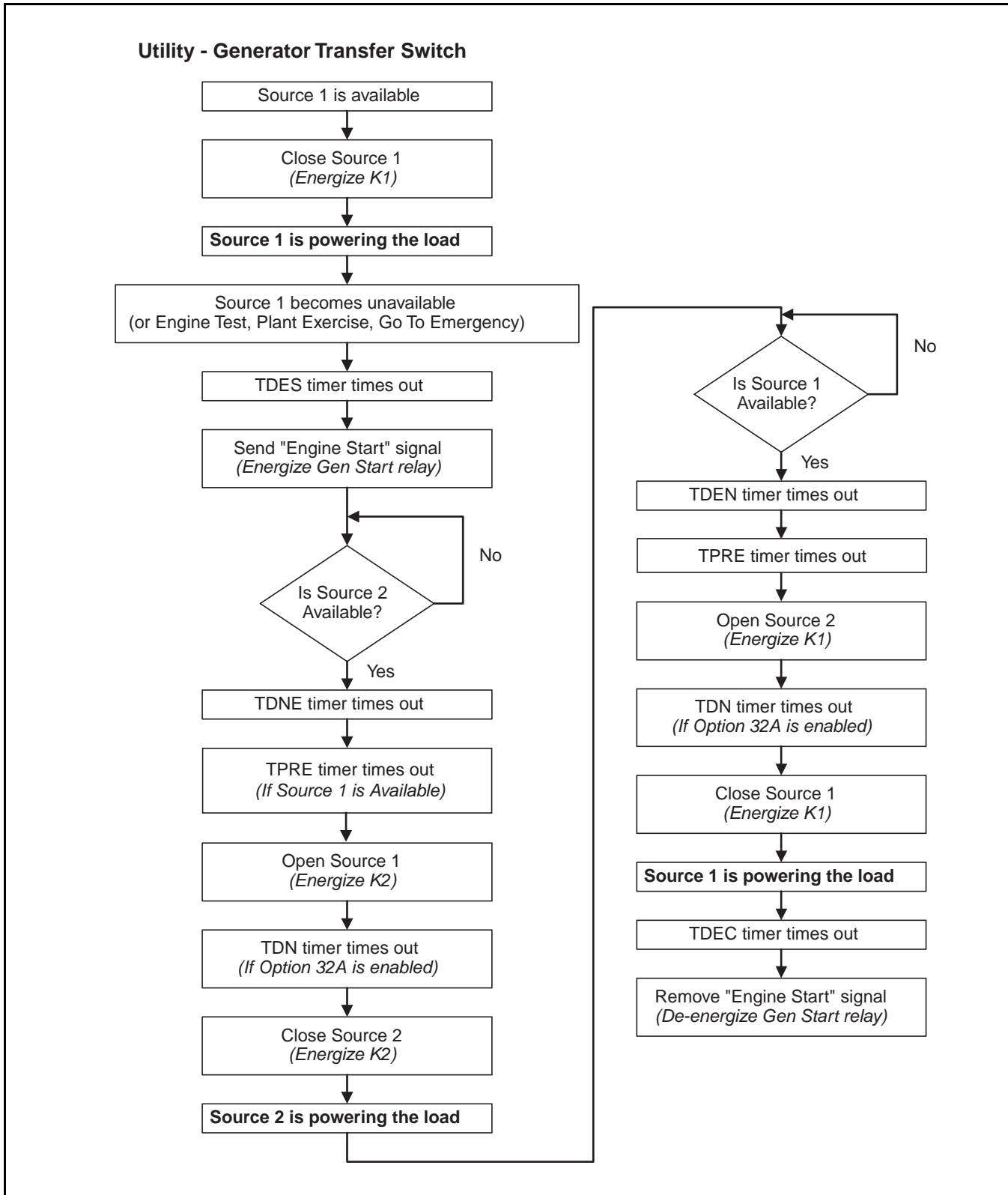

Figure 42. Utility - Generator Transfer Switch

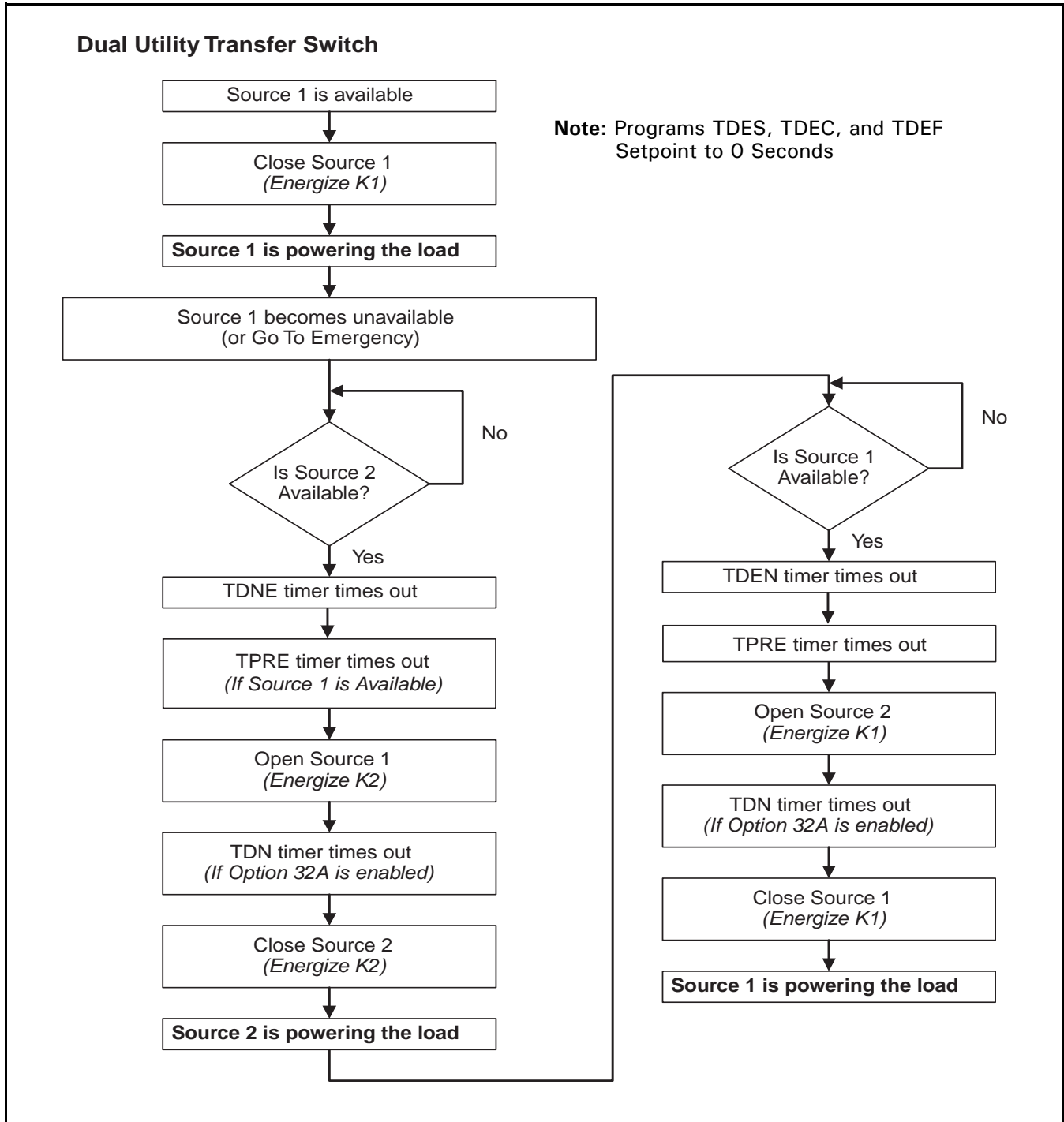

Figure 43. Dual Utility Transfer Switch

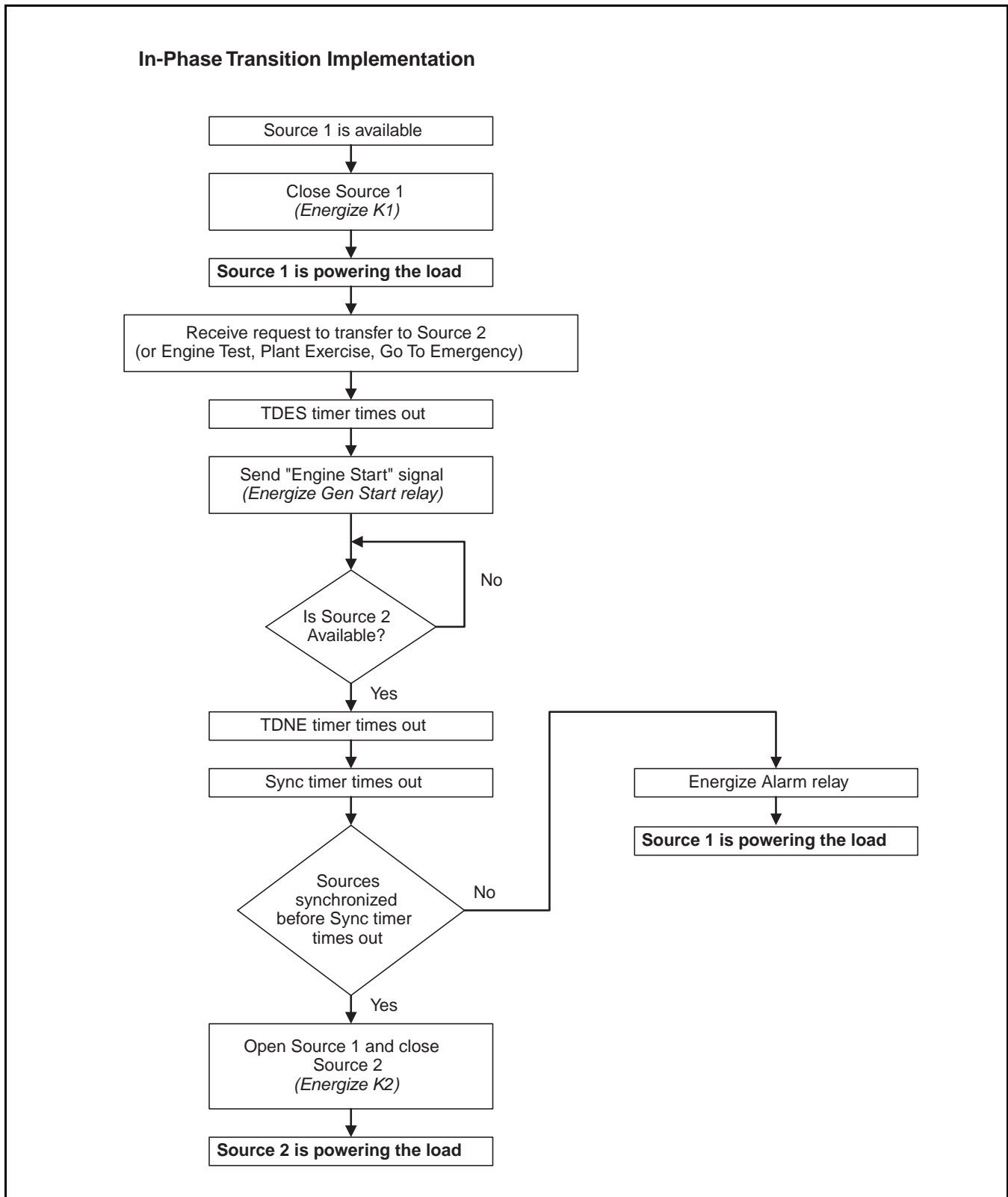

Figure 44. In-Phase Transition Implementation

Table 6. Setpoint Possibilities

Setpoint	Optional Feature	Setpoint Units	Description	Range	Factory Default
New Password		Four Digits	Set New Password	0000 to 9999	0300
TDES		Minutes: Seconds	Time Delay Engine Start	0 to 120 seconds	0:03
TDNE		Minutes: Seconds	Time Delay Normal to Emergency	0 to 1800 seconds	0:00
TDEN		Minutes: Seconds	Time Delay Emergency to Normal	0 to 1800 seconds	5:00
TDEC		Minutes: Seconds	Time Delay Engine Cool-off	0 to 1800 seconds	5:00
NOM FREQ		Hertz	Nominal Frequency	50 or 60 Hz	As ordered
NOM VOLTS		Volts	Nominal Voltage	120 to 600 volts	As ordered
S1 UV DROP		Volts	Source 1 Undervoltage Dropout	97% to 50% of NOMV	80% of NOMV in volts
S2 UV DROP		Volts	Source 2 Undervoltage Dropout	97% to 50% of NOMV	80% of NOMV in volts
S1 UV PICK		Volts	Source 1 Undervoltage Pickup	99% to (1UVD + 2%)	90% of NOMV in volts
S2 UV PICK		Volts	Source 2 Undervoltage Pickup	99% to (2UVD + 2%)	90% of NOMV in volts
S1 OV DROP	X	Volts	Source 1 Overvoltage Dropout	105% to 120%	115% of NOMV in volts
S2 OV DROP	X	Volts	Source 2 Overvoltage Dropout	105% to 120%	115% of NOMV in volts
S1 OV PICK	X	Volts	Source 1 Overvoltage Pickup	(1OVD - 2%) to 103%	110% of NOMV in volts
S2 OV PICK	X	Volts	Source 2 Overvoltage Pickup	(2OVD - 2%) to 103%	110% of NOMV in volts
S1 UF DROP	X	Hertz	Source 1 Underfrequency Dropout	90% to 97% of NOMF	94% of NOMF in hertz
S2 UF DROP		Hertz	Source 2 Underfrequency Dropout	90% to 97% of NOMF	94% of NOMF in hertz
S1 UF PICK	X	Hertz	Source 1 Underfrequency Pickup	(1UFD + 1Hz) to 99%	96% of NOMF in hertz
S2 UF PICK		Hertz	Source 2 Underfrequency Pickup	(2UFD + 1Hz) to 99%	96% of NOMF in hertz
S1 OF DROP	X	Hertz	Source 1 Overfrequency Dropout	103% to 110% of NOMF	106% of NOMF in hertz
S2 OF DROP	X	Hertz	Source 2 Overfrequency Dropout	103% to 110% of NOMF	106% of NOMF in hertz
S1 OF PICK	X	Hertz	Source 1 Overfrequency Pickup	(1OFD - 1Hz) to 101%	104% of NOMF in hertz
S2 OF PICK	X	Hertz	Source 2 Overfrequency Pickup	(2OFD - 1Hz) to 101%	104% of NOMF in hertz
TDN		Minutes: Seconds	Time Delay Neutral	0 to 120 seconds	0:00
PLANT EXER		Days	Plant Exerciser Programming	OFF, DAILY, 7-DAY, 14-DAY or 28 DAY	OFF
PE LOAD XFR			Plant Exerciser Load Transfer	0 or 1 (1 = yes)	0
PE DAY		Days	Plant Exerciser Day of the Week	SUN, MON, TUE, WED, THU, FRI or SAT	
PE HOUR		Hours	Plant Exerciser Hour	0 to 23	0
PE MINUTE		Minutes	Plant Exerciser Minute	0 to 59	0
TEST MODE			Test Mode	0, 1 or 2 (0 = No Load Engine Test, 1 = Load Engine Test, 2 = Disabled)	0
TER		Minutes	Engine run test time	0 min to 600 min	5:00
TPRE		Seconds	Pretransfer delay timer	0 sec to 120 sec	0:00
PHASES			Three phase or single phase	1 or 3	AS ORDERED
VOLT UNBAL	X	Volts	Voltage Unbalanced	0 or 1 (1 = Enabled)	1
UNBAL DROP %	X	Percent	Percent for Unbalanced Voltage Dropout	5 to 20% of Phase to Phase Voltage Unbalance	20%
UNBAL PICK %	X	Percent	Percent for Unbalanced Voltage Pickup	Dropout minus (UNBAL DROP % -2) to 3%	10%
UNBAL DELAY	X	Seconds	Unbalanced Delay Timer	10 to 30	20
TDEF		Seconds	Time Delay Emergency Fail Timer	0 sec to 6 sec	0:06
IN-PHASE	X		In-phase Transition	0 or 1 (1 = Enabled)	0
IP FREQ DIFF	X	Hertz	In-phase Transition Frequency Difference	0.0 Hz to 3.0 Hz	1
SYNC TIME	X	Minutes	In-phase Transition Synchronization Timer	1 min to 60 min	5
PHASE REV	X		Phase Reversal	OFF, ABC, or CBA	OFF

**Table 6. Setpoint Possibilities (cont')**

Setpoint	Optional Feature	Setpoint Units	Description	Range	Factory Default
DST ADJUST			Day Light Savings	0 or 1 (1 = Enabled)	1
LANGUAGE			Selected Language	English, French, Spanish, or Dutch	English
CHANGE TIME/ DATE?			Set Time and Date		
		Hours	Set Hour	0 to 23	Eastern Standard Time
		MINUTES	Set Minute	0 to 59	Eastern Standard Time
		WEEKDAY	Set Weekday	SUN, MON, TUE, WED, THU, FRI or SAT	Eastern Standard Time
		MONTH	Set Month	JAN or 01	Eastern Standard Time
		DAY	Set Day	1 to 31	Eastern Standard Time
		YEAR	Set Year	Current Year	Eastern Standard Time
RESET SYSTEM COUNTERS?				Yes or No	No
RESET ALL?			Resets all System Counters	Yes or No	No
RESET ENGINE RUN?		Hours	Resets ENGINE RUN Counter	0 to 9999	XXXX
RESET S1 CONN		Hours	Resets S1 CONN Counter	0 to 9999	XXXX
RESET S2 CONN		Hours	Resets S2 CONN Counter	0 to 9999	XXXX
RESET S1 AVAIL		Hours	Resets S1 AVAIL Counter	0 to 9999	XXXX
RESET S2 AVAIL		Hours	Resets S2 AVAIL Counter	0 to 9999	XXXX
RESET LOAD ENERG		Hours	Resets LOAD ENERG Counter	0 to 9999	XXXX
RESET TRANSFERS		Hours	Resets TRANSFERS Counter	0 to 9999	XXXX
SAVE SETPOINTS?			Save Changed Setpoints	Yes or No	Yes

See tables in the appendix for Voltage and Frequency Pickup and Dropout settings.

**Step 7:** To change or add a setpoint, select **Yes** when the "Change Setpoints" message appears on the screen. Use the **<Step/Enter>** pushbutton to step through the setpoints.

Use the **<Increase>** and **<Decrease>** pushbuttons to change the setpoint.

When finished scrolling through and changing the desired setpoints, answer **Yes** when the "Save Setpoints?" question appears on the screen. The display will return to the default screen.

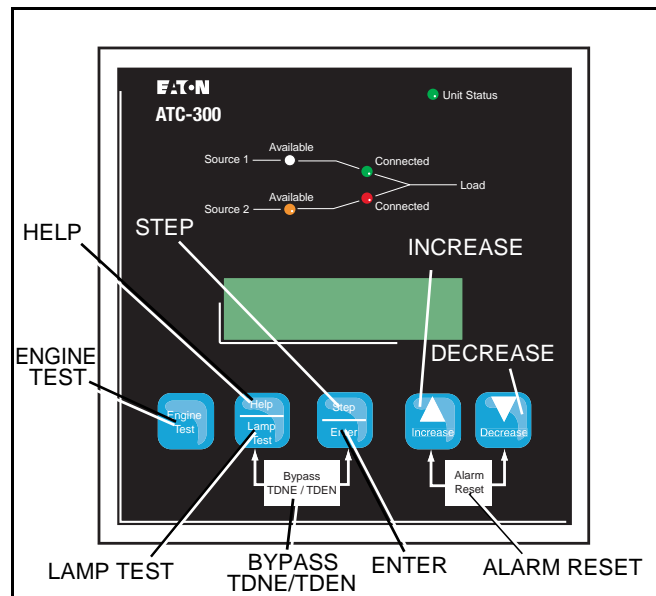

**Figure 45. ATC-300 Pushbuttons**

**WARNING**

**THE GENERATOR SHOULD BE MANUALLY STARTED AND THE OUTPUT CHECKED AND VERIFIED BEFORE PROCEEDING TO STEP 8. IF IMPROPER VOLTAGE/FREQUENCY IS APPLIED TO THE LOAD, THE ATS MAY BE DAMAGED.**

**Step 8:** Manually start the engine generator at the generator controller (Figure 44). Check that the generator is running and the *Source 2 Available* amber LED is lit. Press the **<Step/Enter>** pushbutton, step through the phase voltages, frequency, and message display. If the source message indicates that the source is Good, shut down the generator and place the Genset controller in the Auto-operating position. If the message indicates a problem with the source, the setpoints should be reviewed and the generator checked for proper voltage and frequency output.

**Step 9:** Initiate a Load Test from the front panel of the ATC-300 (Figure 46). This may be done by setting the engine test setpoint to:

1 Load Test

then saving the setpoints. Once the engine test setpoint has been changed and saved, press the **<Engine Test>** pushbutton twice. The generator should start, the ATS should transfer and run on the generator for the set test interval, then proceed to a TDEN countdown and return to Source 1. While the ATS is connected to Source 2, use a voltmeter to check for correct system voltage on the load terminals of the ATS. Check all phases on a 3-phase system. Voltage measurements should be taken phase to phase and phase to neutral. A load test will cause a momentary power outage during transfer.

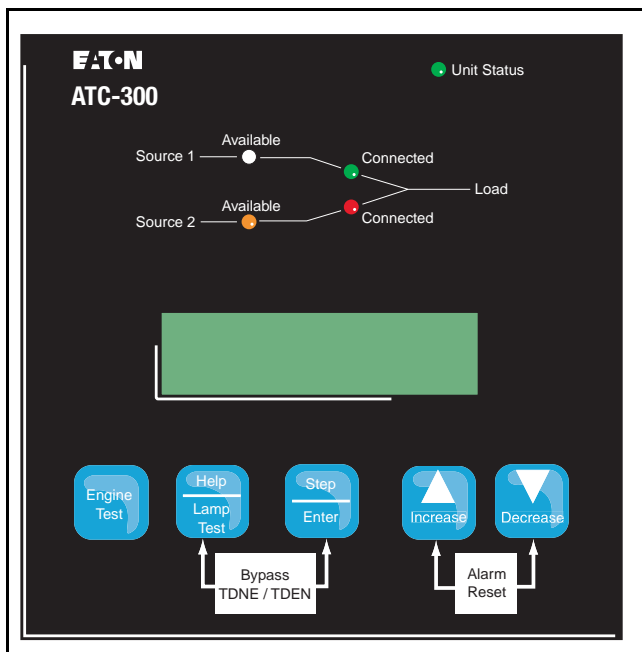

Figure 46. ATC-300 Logic.

**Step 10:** ATH3/ATV3 Power Failure Test - Initiate a Load Test by simulating an actual power failure.

1. This should be done by opening the upstream breaker or fused disconnect switch.
2. If the ATS is Service Equipment Rated with no upstream disconnect, use the Source 1 Control Circuit Fused Disconnect to simulate a power failure (Figure 47).

The Source 1 Control Circuit Fused Disconnect can be found in one of two places. The first would be located directly beside the Source 1 breaker. The second would be located on the transformer panel/customer connection panel. The Source 1 Control Circuit Fused Disconnect is the disconnect marked Source 1. The disconnect switch should be in the ON position for Source 1 operation. Turning the switch to the OFF position will simulate a Source 1 power outage.



Figure 47. Source 1 Control Disconnect in the ON Position.

3. The generator should start and the ATS should transfer to Source 2.
4. After transfer, close the upstream breaker, or close the Source 1 Control Circuit Fused Disconnect. The TDEN timer should begin counting, and, when complete, the ATS should transfer to Source 1. The TDEC should time out and shut the Source 2 power unit down.

**NOTICE**

WHILE PERFORMING TESTING, IF AN UNDESIRE OR UNDOCUMENTED RESULT OCCURS, FIRST CONTACT THE LOCAL GENSET DEALER. IF THE RESULT IS NOT CORRECTED, CONTACT THE EATON PRODUCT INTEGRITY CENTER AT 1-800-210-6208.

---

**APPENDIX A: Pickup / Dropout Tables**

UnderVoltage Pickup / Dropout Table								
Percentage	Voltage							
	120	208	220	240	380	415	480	600
97	116	202	213	233	369	403	466	582
96	115	200	211	230	365	398	461	576
95	114	198	209	228	361	394	456	570
94	113	196	207	226	357	390	451	564
93	112	193	205	223	353	386	446	558
92	110	191	202	221	350	382	442	552
91	109	189	200	218	346	378	437	546
<b>90</b>	<b>108</b>	<b>187</b>	<b>198</b>	<b>216</b>	<b>342</b>	<b>374</b>	<b>432</b>	<b>540</b> Pickup
89	107	185	196	214	338	369	427	534
88	106	183	194	211	334	365	422	528
87	104	181	191	209	331	361	418	522
86	103	179	189	206	327	357	413	516
85	102	177	187	204	323	353	408	510
84	101	175	185	202	319	349	403	504
83	100	173	183	199	315	344	398	498
82	98	171	180	197	312	340	394	492
81	97	168	178	194	308	336	389	486
<b>80</b>	<b>96</b>	<b>166</b>	<b>176</b>	<b>192</b>	<b>304</b>	<b>332</b>	<b>384</b>	<b>480</b> Dropout
79	95	164	174	190	300	328	379	474
78	94	162	172	187	296	324	374	468
77	92	160	169	185	293	320	370	462
76	91	158	167	182	289	315	365	456
75	90	156	165	180	285	311	360	450
74	89	154	163	178	281	307	355	444
73	88	152	161	175	277	303	350	438
72	86	150	158	173	274	299	346	432
71	85	148	156	170	270	295	341	426
70	84	146	154	168	266	291	336	420
69	83	144	152	166	262	286	331	414
68	82	141	150	163	258	282	326	408
67	80	139	147	161	255	278	322	402
66	79	137	145	158	251	274	317	396
65	78	135	143	156	247	270	312	390
64	77	133	141	154	243	266	307	384
63	76	131	139	151	239	261	302	378
62	74	129	136	149	236	257	298	372
61	73	127	134	146	232	253	293	366
60	72	125	132	144	228	249	288	360
59	71	123	130	142	224	245	283	354
58	70	121	128	139	220	241	278	348
57	68	119	125	137	217	237	274	342
56	67	116	123	134	213	232	269	336
55	66	114	121	132	209	228	264	330
54	65	112	119	130	205	224	259	324
53	64	110	117	127	201	220	254	318
52	62	108	114	125	198	216	250	312
51	61	106	112	122	194	212	245	306
50	60	104	110	120	190	208	240	300

OverVoltage Pickup / Dropout Table								
Percentage	Voltage							
	120	208	220	240	380	415	480	600
120	144	250	264	288	456	498	576	720
119	143	248	262	286	452	494	571	714
118	142	245	260	283	448	490	566	708
117	140	243	257	281	445	486	562	702
116	139	241	255	278	441	481	557	696
<b>115</b>	<b>138</b>	<b>239</b>	<b>253</b>	<b>276</b>	<b>437</b>	<b>477</b>	<b>552</b>	<b>690</b> Dropout
114	137	237	251	274	433	473	547	684
113	136	235	249	271	429	469	542	678
112	134	233	246	269	426	465	538	672
111	133	231	244	266	422	461	533	666
<b>110</b>	<b>132</b>	<b>229</b>	<b>242</b>	<b>264</b>	<b>418</b>	<b>457</b>	<b>528</b>	<b>660</b> Pickup
109	131	227	240	262	414	452	523	654
108	130	225	238	259	410	448	518	648
107	128	223	235	257	407	444	514	642
106	127	220	233	254	403	440	509	636
105	126	218	231	252	399	436	504	630

UnderFrequency Pickup / Dropout Table		
Percentage	Frequency	
	50	60
97	49	58
<b>96</b>	<b>48</b>	<b>58</b> Pickup
95	48	57
<b>94</b>	<b>47</b>	<b>56</b> Dropout
93	47	56
92	46	55
91	46	55
90	45	54

OverFrequency Pickup / Dropout Table		
Percentage	Frequency	
	50	60
110	55	66
109	55	65
108	54	65
107	54	64
<b>106</b>	<b>53</b>	<b>64</b> Dropout
105	53	63
<b>104</b>	<b>52</b>	<b>62</b> Pickup
103	52	62

---

**NOTES:**

**NOTES:**

This instruction booklet is published solely for information purposes and should not be considered all-inclusive. If further information is required, you should consult Eaton.

Sale of the product(s) shown in this literature is subject to terms and conditions outlined in appropriate Eaton selling policies or other contractual agreements between the parties. This literature is not intended to and does not enlarge or add to any such contract. The sole source governing the rights and remedies of any purchaser of this equipment is the contract between the purchaser and Eaton.

NO WARRANTIES, EXPRESSED OR IMPLIED, INCLUDING WARRANTIES OF FITNESS FOR A PARTICULAR PURPOSE OR MERCHANTABILITY, OR WARRANTIES ARISING FROM COURSE OF DEALING OR USAGE OF TRADE, ARE MADE REGARDING THE INFORMATION, RECOMMENDATIONS AND DESCRIPTIONS CONTAINED HEREIN. In no event will Eaton be responsible to the purchaser or user in contract, in tort (including negligence), strict liability or otherwise for any special, indirect, incidental or consequential damage or loss whatsoever, including but not limited to damage or loss of use of equipment, plant or power system, cost of capital, loss of power, additional expenses in the use of existing power facilities, or claims against the purchaser or user by its customers resulting from the use of the information, recommendations and description contained herein.

Effective 04/04  
EATON Electrical  
1000 Cherrington Parkway  
Moon Township, PA 15108-4312  
U.S.A.  
tel: 1-800-525-2000  
[www.eatonelectrical.com](http://www.eatonelectrical.com)