

ATC3C2X30400XRU

AUTOMATIC OPEN TRANSFER CONTACTOR SWITCH
 ATC-300+ CONTROL, 2 POSITION CONTACTOR
 FIXED MOUNTED
 3 POLE, 400 AMPS
 480/277V 60HZ, 3 PHASE, 4 WIRE
 TYPE-3R ENCLOSURE, UL 1008 LISTED

FEATURES INCLUDED:

- 1A TIME DELAY NORMAL TO EMERGENCY ADJ 0-1800 sec
- 2A TIME DELAY ENGINE START ADJ 0-120 sec
- 3A TIME DELAY EMERGENCY TO NORMAL ADJ 0-1800 sec
- 4A TIME DELAY ENGINE COOL-OFF ADJ 0-1800 sec
- 5H EMERGENCY (S2) SENSING PHASE REVERSAL
- 5J EMERGENCY (S2) SENSING ALL PHASE UNDERVOLTAGE/UNDER FREQ
- 5K EMERGENCY (S2) SENSING ALL PHASE OVERVOLTAGE/OVER FREQ
- 5L EMERGENCY (S2) SENSING ALL PHASE VOLTAGE UNBALANCE
- 6B ENGINE TEST PUSHBUTTON
- 7A TIME DELAY ENGINE FAIL ADJ 0-6 sec
- 8C TIME DELAY BYPASS EMERGENCY TO NORMAL
- 8D TIME DELAY BYPASS NORMAL TO EMERGENCY
- 12C LED INDICATION NORMAL (S1) CONNECTED
- 12D LED INDICATION EMERGENCY (S2) CONNECTED
- 12G LED INDICATION NORMAL (S1) AVAILABLE
- 12H LED INDICATION EMERGENCY (S2) AVAILABLE
- 14G AUX RELAY CONTACTS NORMAL (S1) AVAILABLE 2 FORM C
- 14H AUX RELAY CONTACTS EMERGENCY (S2) AVAILABLE 2 FORM C
- 15E POSITION INDICATION CONTACT NORMAL (S1) AVAILABLE 1 FORM C
- 15F POSITION INDICATION CONTACT EMERGENCY (S2) AVAILABLE 1 FORM C
- 23K PLANT EXERCISER 7/14/28 DAY LOAD/NO LOAD 0-600 min
- 26D GO TO EMERGENCY (S2) INPUT
- 26H NORMAL (S1) SENSING PHASE REVERSAL
- 26J NORMAL (S1) SENSING ALL PHASE UNDERVOLTAGE/UNDER FREQ
- 26K NORMAL (S1) SENSING ALL PHASE OVERVOLTAGE/OVER FREQ
- 26L NORMAL (S1) SENSING ALL PHASE VOLTAGE UNBALANCE
- 29J SELECTABLE AUTOMATIC OR NON-AUTOMATIC RETRANSFER w/FAILSAFE
- 32F IN-PHASE TRANSITION
- 35A PRETRANSFER SIGNAL CONTACTS 1 FORM C
- 42 IBC/CBC SEISMIC QUALIFIED
- 48F COMMUNICATIONS MODBUS w/o MPOI
- 49C MULTI-TAP VOLTAGE TRANSFORMER

REQUIRED FOR SEISMIC, RECOMMENDED FOR ALL APPLICATIONS:
 USE 4, 1/2-13 UNC GRADE 5 OR BETTER HEX HEAD BOLTS AND WASHERS.
 THESE BOLTS ARE TO BE TORQUED TO 75 FT. LBS. (102 NM).

NOTES:

- 1 APPROXIMATE SHIPPING WEIGHT = 250 LBS [113 KG]
- 2 DIMENSIONS SHOWN IN INCHES [MILLIMETERS]
- 3 AUTOMATIC & NON-AUTOMATIC CONTROLS PROVIDED BASED ON CUSTOMER ORDER INFORMATION.
- 4 TRANSFORMER PACK IS NOT INCLUDED WITH 240/120V, 1 PHASE OR 208/120V SYSTEMS.
- 5 FOR SWITCHED NEUTRAL APPLICATIONS, CONNECT TO TERMINALS MARKED 'NN', 'EN', AND 'LN'. NEUTRAL ASSEMBLY WILL NOT BE PROVIDED.

ONE LINE DIAGRAM

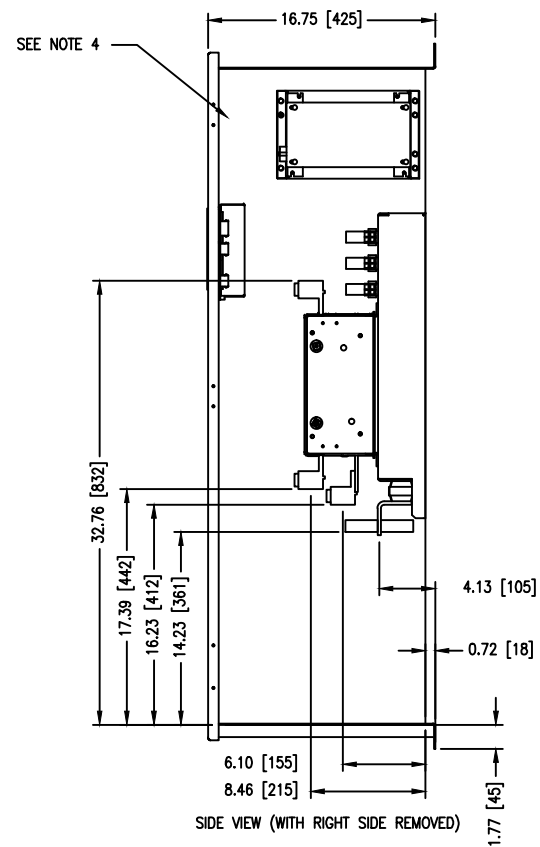
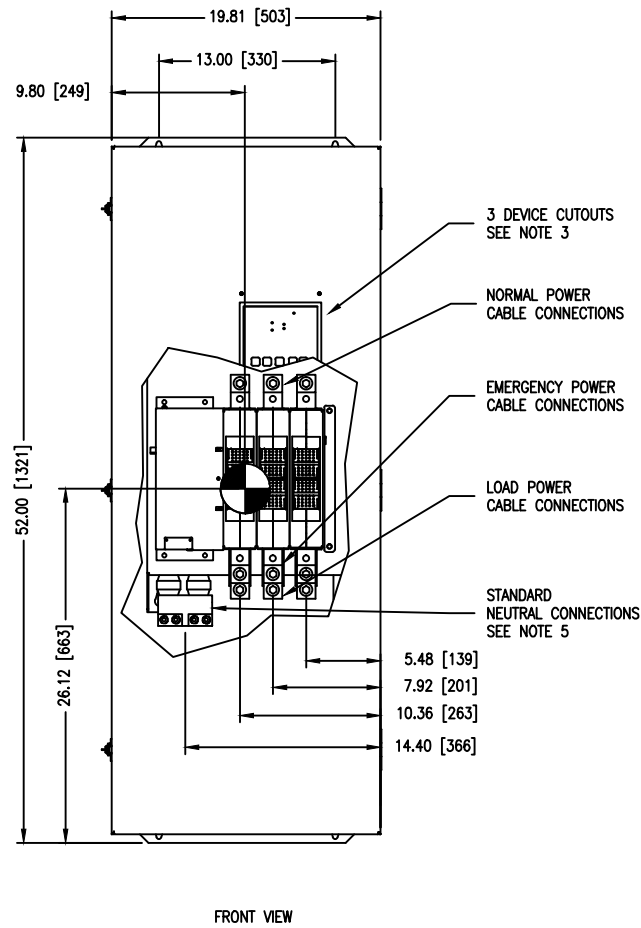
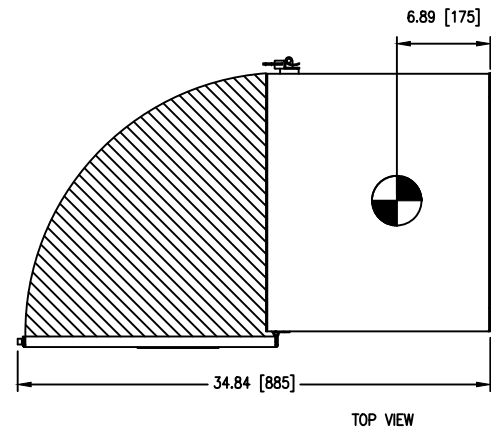
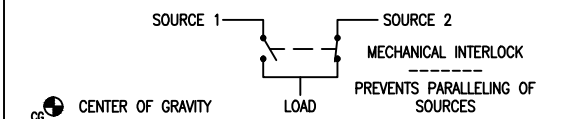

01 REVISION

DFTR		DATE	THE INFORMATION ON THIS DOCUMENT WAS CREATED BY EATON CORPORATION. IT WAS DISCLOSED IN CONFIDENCE AND IS ONLY TO BE USED FOR THE PURPOSE IN WHICH IT WAS SUPPLIED.	
APPD		DATE	TITLE AUTOMATIC OPEN TRANSFER CONTACTOR SWITCH 480V 2 POSITION 225-400 AMP ATC-300+ CONTROLLER	
FEDERAL ID NO. 88725	S.O.		TYPE ATC3C2X30400XRU	OUTLINE
PRODUCT CODE AT	REVISION 01	DESIGNATION 400A	G.O. -	DWG 400A 01
				SHEET 1 OF 4

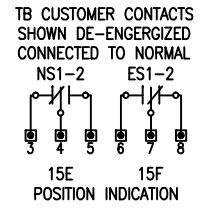
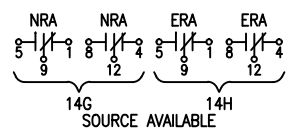
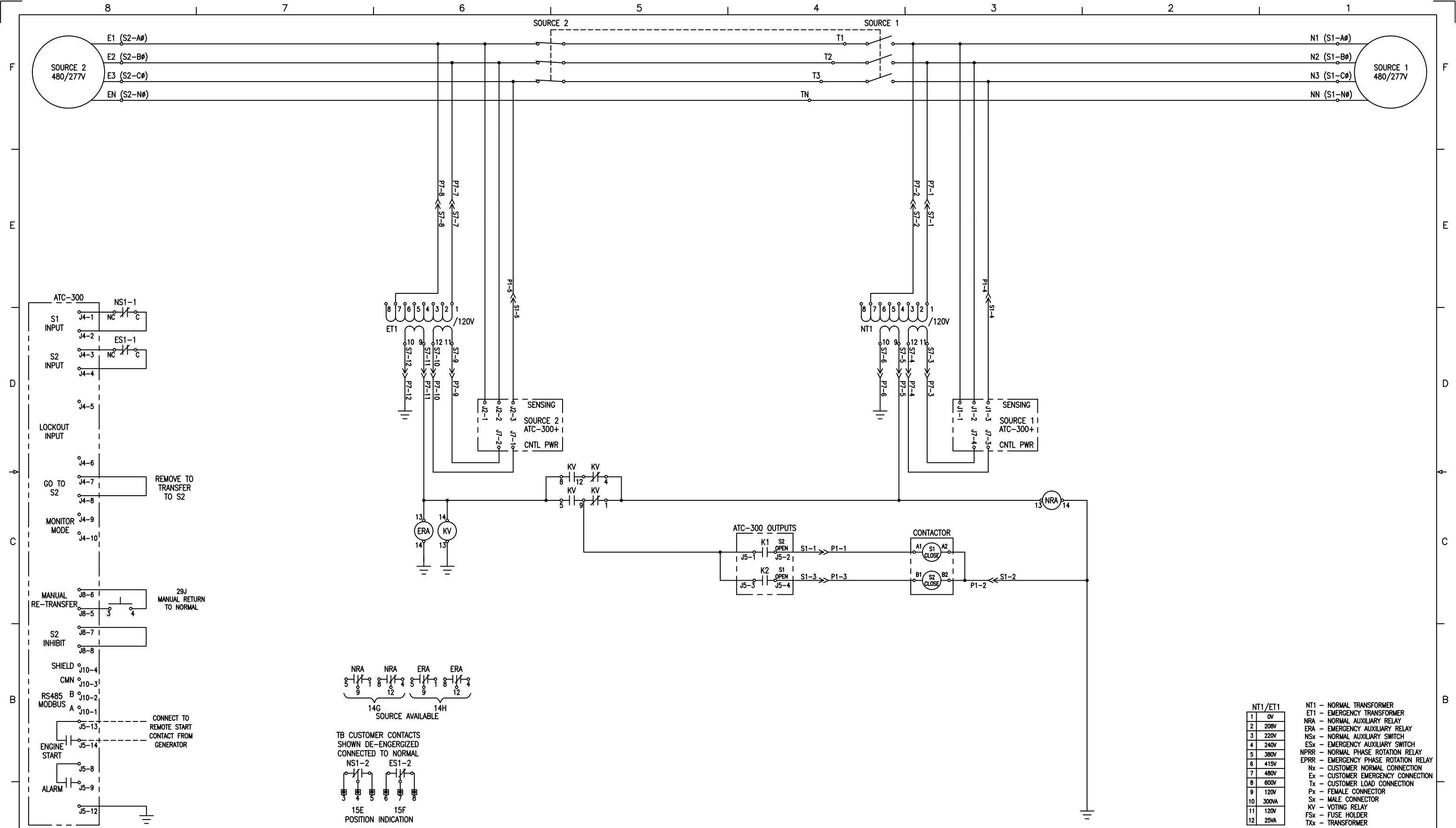

NT1/ET1	
1	0V
2	208V
3	220V
4	240V
5	380V
6	415V
7	480V
8	600V
9	120V
10	300VA
11	120V
12	25VA

- NT1 - NORMAL TRANSFORMER
- ET1 - EMERGENCY TRANSFORMER
- NRA - NORMAL AUXILIARY RELAY
- ERA - EMERGENCY AUXILIARY RELAY
- NSx - NORMAL AUXILIARY SWITCH
- ESx - EMERGENCY AUXILIARY SWITCH
- NPRR - NORMAL PHASE ROTATION RELAY
- EPRR - EMERGENCY PHASE ROTATION RELAY
- Nx - CUSTOMER NORMAL CONNECTION
- Ex - CUSTOMER EMERGENCY CONNECTION
- Px - FEMALE CONNECTOR
- Tx - CUSTOMER LOAD CONNECTION
- Sx - MALE CONNECTOR
- KV - VOTING RELAY
- FSx - FUSE HOLDER
- TXx - TRANSFORMER

01
REVISION

FEDERAL ID NO. 88725		S.O.		DATE		DATE		THE INFORMATION ON THIS DOCUMENT WAS CREATED BY EATON CORPORATION. IT WAS DISCLOSED IN CONFIDENCE AND IS ONLY TO BE USED FOR THE PURPOSE IN WHICH IT WAS SUPPLIED.	
PRODUCT CODE AT		REVISION 01		DESIGNATION 400A		G.O. -		DWG 400A S1	
				TITLE AUTOMATIC OPEN TRANSFER CONTACTOR SWITCH 480V 2 POSITION 225-400 AMP ATC-300+ CONTROLLER		TYPE ATC3C2X30400XRU		SCHEMATIC	
				SHEET 2 OF 4		SHEET 2 OF 4			

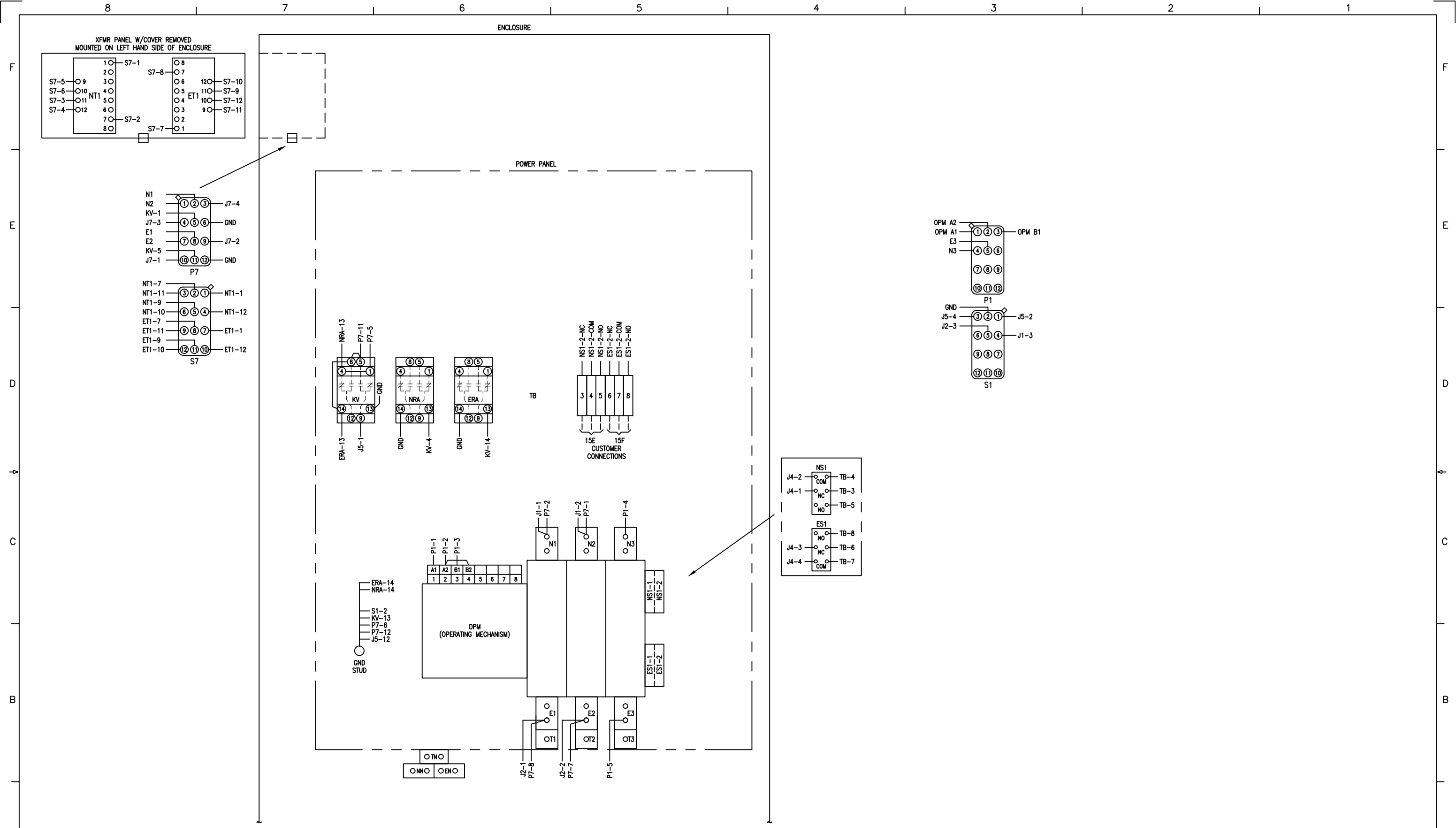

01
REVISION

DFTR		DATE	THE INFORMATION ON THIS DOCUMENT WAS CREATED BY EATON CORPORATION. IT WAS DISCLOSED IN CONFIDENCE AND IS ONLY TO BE USED FOR THE PURPOSE IN WHICH IT WAS SUPPLIED.	
APPD		DATE	 TITLE AUTOMATIC OPEN TRANSFER CONTACTOR SWITCH 480V 2 POSITION 225-400 AMP ATC-300+ CONTROLLER	
FEDERAL ID NO. 88725	S.O.		TYPE ATC3C2X30400XRU	DIAGRAM
PRODUCT CODE AT	REVISION 01	DESIGNATION 400A	G.O. -	DWG 400A W1
			SHEET 3 OF 4	

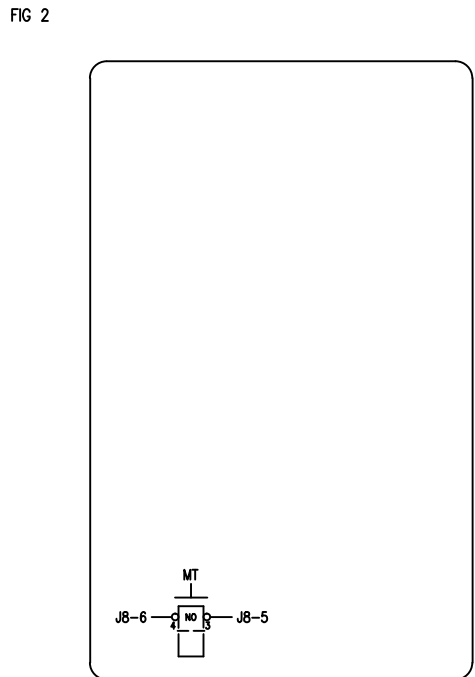
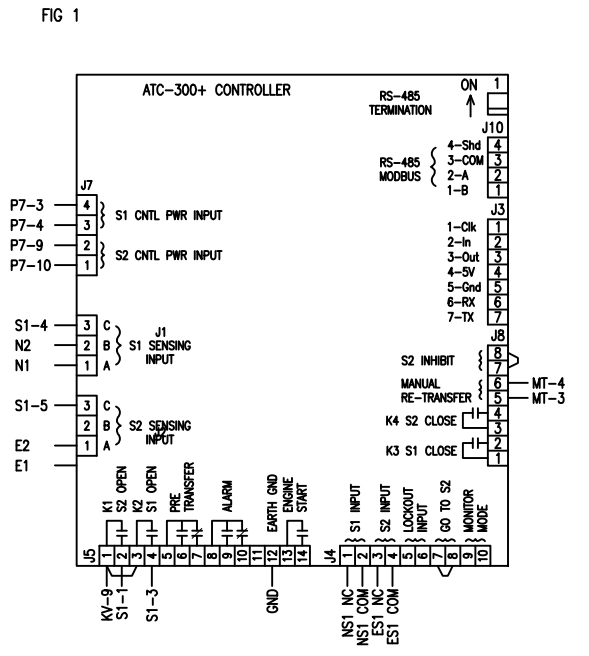
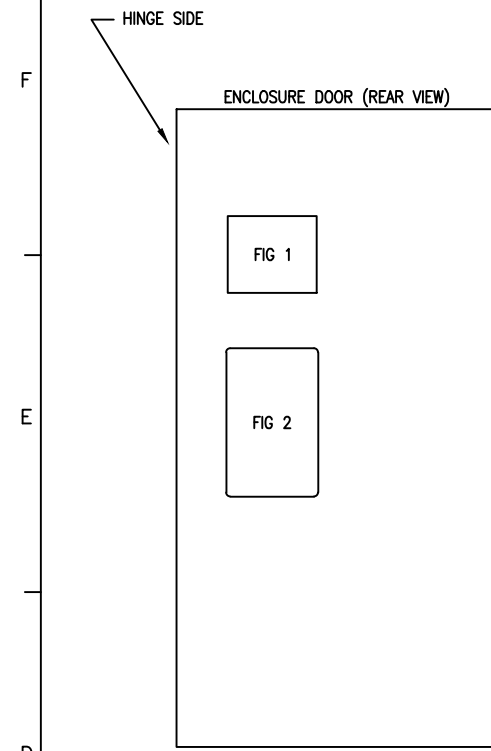

29J (MT) PRESS TO RETURN TO SOURCE 1

01 REVISION	DFTR		DATE	THE INFORMATION ON THIS DOCUMENT WAS CREATED BY EATON CORPORATION. IT WAS DISCLOSED IN CONFIDENCE AND IS ONLY TO BE USED FOR THE PURPOSE IN WHICH IT WAS SUPPLIED.	
	APPD		DATE		
	FEDERAL ID NO. 88725		S.O.	TITLE AUTOMATIC OPEN TRANSFER CONTACTOR SWITCH 480V 2 POSITION 225-400 AMP ATC-300+ CONTROLLER	
	PRODUCT CODE AT		REVISION 01	DESIGNATION 400A	TYPE ATC3C2X30400XRU DIAGRAM G.O. - DWG 400A W2 SHEET 4 OF 4