



Powering Business Worldwide

## ATC-900 Magnum Transfer Switch O & M Manual

Instruction Booklet

<i>Description</i>	<i>Page</i>
Introduction .....	3
Receiving, Handling, and Storage .....	10
Equipment Description .....	10
Installation and Wiring .....	16
Operation .....	22
Drawout and Fixed Switching Devices .....	24
Operation of the Bypass Isolation Transfer Switch .....	37
Testing and Problem Solving .....	31
Maintenance .....	33
Renewal Parts Guide .....	35



4000A Magnum



2000A Magnum

**⚠ WARNING**

READ AND UNDERSTAND THE INSTRUCTIONS CONTAINED HEREIN- AFTER BEFORE ATTEMPTING TO UNPACK, ASSEMBLE, OPERATE, OR MAINTAIN THIS EQUIPMENT.

HAZARDOUS VOLTAGES ARE PRESENT INSIDE TRANSFER SWITCH ENCLOSURES THAT CAN CAUSE DEATH OR SEVERE PERSONAL INJURY. FOLLOW PROPER INSTALLATION, OPERATION, AND MAINTENANCE PROCEDURES TO AVOID THESE VOLTAGES.

TRANSFER SWITCH EQUIPMENT COVERED BY THIS INSTRUCTION BOOK IS DESIGNED AND TESTED TO OPERATE WITHIN ITS NAME-PLATE RATINGS. OPERATION OUTSIDE OF THESE RATINGS MAY CAUSE THE EQUIPMENT TO FAIL RESULTING IN DEATH, SERIOUS BODILY INJURY, AND/OR PROPERTY DAMAGE. ALL RESPONSIBLE PERSONNEL SHOULD LOCATE THE DOOR MOUNTED EQUIPMENT NAMEPLATE AND BE FAMILIAR WITH THE INFORMATION PROVIDED ON THE NAMEPLATE. A TYPICAL EQUIPMENT NAMEPLATE IS SHOWN IN FIGURE 1.

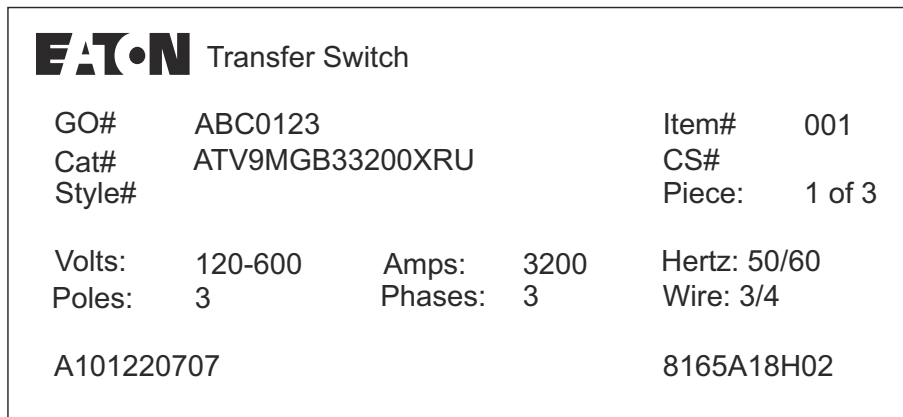

Figure 1. Typical Automatic Transfer Switch Equipment Nameplate.

**NOTICE**

A FINAL INSPECTION OF THE EQUIPMENT SHOULD BE PERFORMED PRIOR TO ENERGIZING THE TRANSFER SWITCH.

- Step 1:** Remove any dirt or debris that may have collected during shipment or installation. NEVER use high pressure blowing air. This could drive dirt or other foreign objects into electrical or mechanical components which could cause damage. Use an industrial quality vacuum cleaner to remove any dirt or foreign objects.
- Step 2:** Be certain all cable connections are correct and that the phase rotation of both sources match.
- Step 3:** Inspect the engine start connections and verify the correct connection of all control wires.

- Step 4:** Check all programmable setpoints and adjust as necessary. In addition, adjust any optional accessories as required.
- Step 5:** Be certain that the actual lug torque values are in keeping with the requirements outlined in the instruction book to insure the integrity of power connections.
- Step 6:** Check to be sure that all covers and barriers are properly installed and fastened.

ALL POSSIBLE CONTINGENCIES WHICH MAY ARISE DURING INSTALLATION, OPERATION, OR MAINTENANCE, AND ALL DETAILS AND VARIATIONS OF THIS EQUIPMENT DO NOT PURPORT TO BE COVERED BY THESE INSTRUCTIONS. IF FURTHER INFORMATION IS DESIRED BY THE PURCHASER REGARDING HIS PARTICULAR INSTALLATION, OPERATION, OR MAINTENANCE OF PARTICULAR EQUIPMENT, CONTACT AN EATON REPRESENTATIVE.

## Section 1: Introduction

### 1.1 Preliminary Comments and Safety Precautions

This technical document is intended to cover most aspects associated with the installation, application, operation, and maintenance of transfer switch equipment with ratings from 800 through 5000 amperes (A), except for the specific logic used to control the equipment. It is provided as a guide for authorized and qualified personnel only. Please refer to the specific WARNING and CAUTION in Section 1.1.2 before proceeding. If further information is required by the purchaser regarding a particular installation, application, or maintenance activity, contact an Eaton representative. For information associated with the control, refer to the separate instruction book pertaining to the logic package installed in the switch.

#### 1.1.1 Warranty and Liability Information

No warranties, expressed or implied, including warranties of fitness for a particular purpose of merchant-ability, or warranties arising from course of dealing or usage of trade, are made regarding the information, recommendations and descriptions contained herein. In no event will Eaton be responsible to the purchaser or user in contract, in tort (including negligence), strict liability or otherwise for any special, indirect, incidental or consequential damage or loss whatsoever, including but not limited to damage or loss of use of equipment, plant or power system, cost of capital, loss of power, additional expenses in the use of existing power facilities, or claims against the purchaser or user by its customers resulting from the use of the information and descriptions contained herein.

#### 1.1.2 Safety Precautions

All safety codes, safety standards, and/or regulations must be strictly observed in the installation, operation, and maintenance of this device.

---

### WARNING

**THE WARNINGS AND CAUTIONS INCLUDED AS PART OF THE PROCEDURAL STEPS IN THIS DOCUMENT ARE FOR PERSONNEL SAFETY AND PROTECTION OF EQUIPMENT FROM DAMAGE. AN EXAMPLE OF A TYPICAL WARNING LABEL HEADING IS SHOWN ABOVE TO FAMILIARIZE PERSONNEL WITH THE STYLE OF PRESENTATION. THIS WILL HELP TO INSURE THAT PERSONNEL ARE ALERT TO WARNINGS, WHICH APPEAR THROUGHOUT THE DOCUMENT. IN ADDITION, CAUTIONS ARE ALL UPPER CASE AND BOLDFACE.**

---

### CAUTION

**COMPLETELY READ AND UNDERSTAND THE MATERIAL PRESENTED IN THIS DOCUMENT BEFORE ATTEMPTING INSTALLATION, OPERATION, OR APPLICATION OF THE EQUIPMENT. IN ADDITION, ONLY QUALIFIED PERSONS SHOULD BE PERMITTED TO PERFORM ANY WORK ASSOCIATED WITH THE EQUIPMENT. ANY WIRING INSTRUCTIONS PRESENTED IN THIS DOCUMENT MUST BE FOLLOWED PRECISELY. FAILURE TO DO SO COULD CAUSE PERMANENT EQUIPMENT DAMAGE.**

---



---

### WARNING

**THE CLOSED TRANSITION PRODUCT CONTAINS A SPECIAL CONTACT ARRANGEMENT (OVERLAPPING CONTACTS). MISUSE CAN RESULT IN DEATH, SEVERE PERSONAL INJURY, AND/OR PROPERTY DAMAGE.**

---

### 1.2 General Information

Transfer switches are used to protect critical electrical loads against loss of power. The Source 1 power source of the load is backed-up by a Source 2 power source. A transfer switch is connected to both the Source 1 and Source 2 power sources and supplies the load with power from one of these two sources. In the event that power is lost from the Source 1 power source, the transfer switch transfers the load to the Source 2 power source. This transfer can be automatic or manual, depending upon the type of transfer switch equipment being used. Once Source 1 power is restored, the load is automatically or manually transferred back to the Source 1 power source, again depending upon the type of transfer equipment being used (Figure 2).

In addition, the Eaton closed transition transfer switch may be applied where it is desirable to avoid any momentary power interruptions. Although the closed transition switch is not a substitute for an uninterruptable power source (UPS), it does eliminate power interruptions to loads except to those caused by power sources or equipment external to the transfer switch. If both sources are acceptable as determined by the IQ Transfer logic, a make-before-break transfer is performed during a transfer test or retransfer operation.

#### 1.2.1 Transfer Switch Types

There are four types of transfer switch equipment.

##### *Automatic Transfer Switch*

Automatic transfer switches (ATSs) automatically perform the transfer function. They consist of three basic elements:

1. Main contacts to connect and disconnect the load to and from the source of power.
2. Intelligence/supervisory circuits to constantly monitor the condition of the power sources and thus provide the intelligence necessary for the switch and related circuit operation.
3. A transfer mechanism to effect the transfer of the main contacts from source to source.

**Basic Transfer Switch (Power Panel)**

The basic transfer switch is designed for use with customer furnished logic. It is similar in design to the automatic version, except the intelligence circuit (logic panel) and voltage selection panel are omitted. All control devices are the customer's responsibility.

**Non-Automatic Transfer Switch (Electrically Operated)**

Non-automatic transfer switches are manually initiated, electrically operated devices for applications where automatic load transfer is not required.

**Bypass Isolation Transfer Switch**

The bypass isolation switch is designed for applications where maintenance, inspection, and testing must be performed while maintaining continuous power to the load (Figures 3 and 4). This is typically required in critical life support systems and standby power situations calling for safe system maintenance with no power disruptions. Such a design allows for the quick removal of the different switching devices for inspection, maintenance, or replacement.

The ATS, non-automatic transfer switch (electrically operated), and bypass isolation transfer switch are the available types for the configuration described in this manual.

Operation of the ATS and the bypass isolation switch only are discussed in this manual (Sections 5 and 7 respectively).

**1.2.2 Design Configuration**

The Eaton transfer switch is a rugged, compact design utilizing power case switches or power case circuit breakers to transfer essential loads from one power source to another. Open transition switching devices are interlocked to prevent both switching devices from being closed at the same time. The versatile design, in addition to standard transfer functions, offers an optional integral thermal and short circuit protection in either or both switching devices.

The switching devices are in a compact vertical arrangement. The logic can be easily disconnected from the switching device without disturbing critical connections. The enclosure is free standing, and, by using the specially supplied cleats, the switch is (Option 42) OSHPD Seismic Certified (3200 A and below). The terminals are mounted in the rear of the switch, permitting rear, top, bottom, or side cable or bus bar entrance.

The switching devices have a high withstand rating (Table 1). The high-speed, stored-energy switching mechanism guarantees a transfer time of less than 5 cycles.

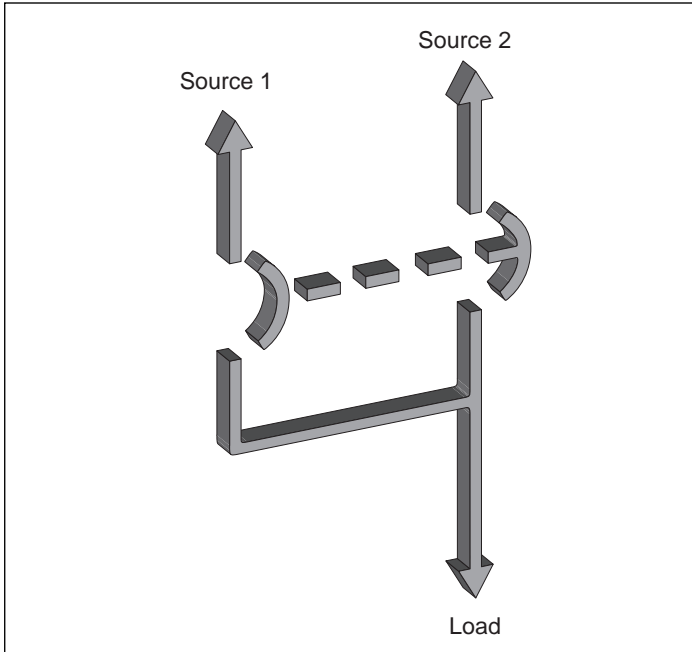

Figure 2. Typical Load Transfer Switch (Switching Device Type) Schematic.

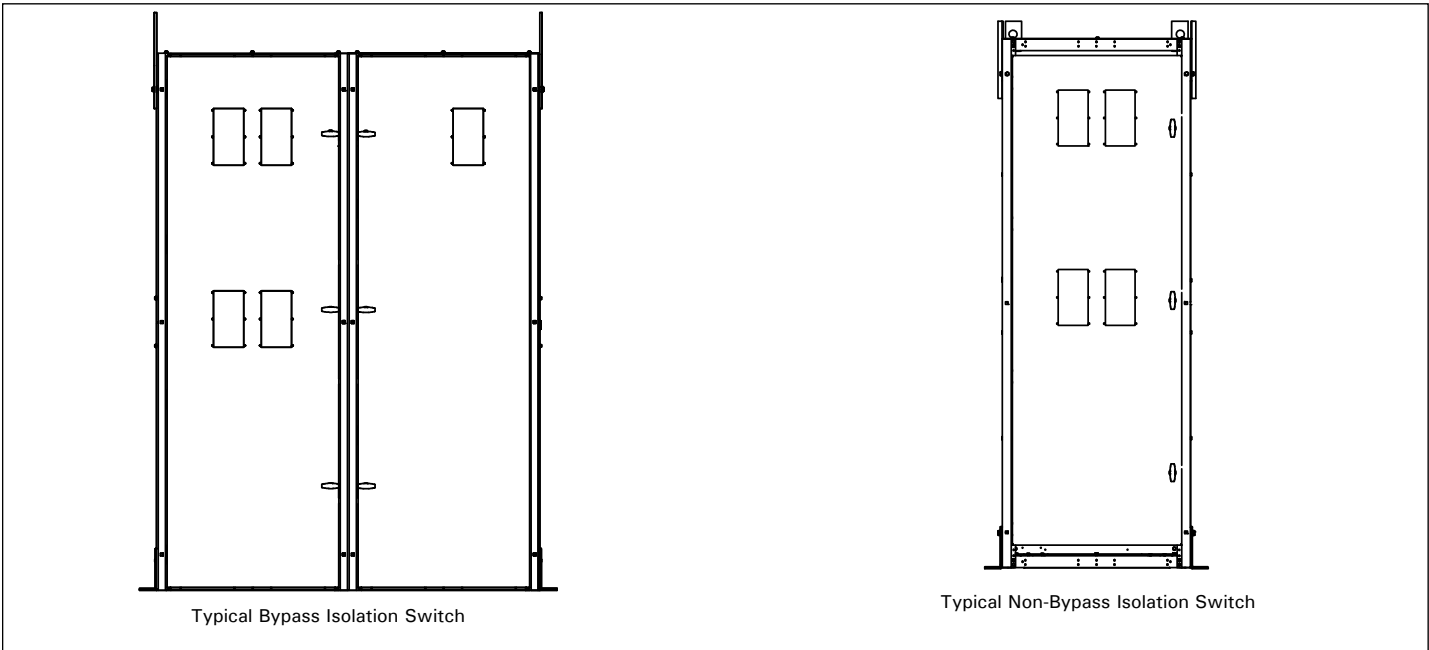
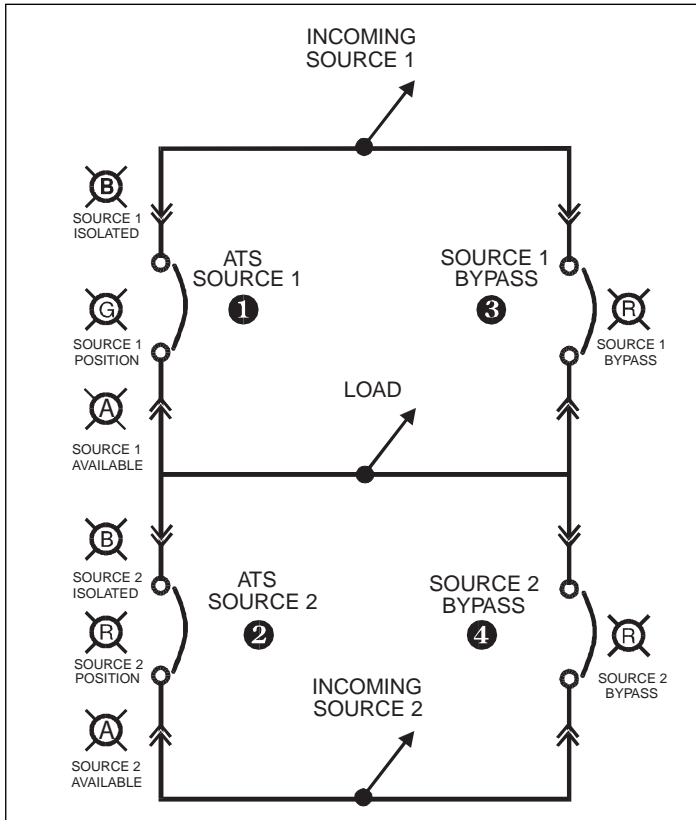

Figure 3. Typical Bypass Isolation Switch.



**Figure 4. Typical Bypass Isolation Switch Schematic.**

**Table 1. System Coordination Information – Withstand, Closing and Interrupting Ratings**

TRANSFER SWITCH AMPERE RATING	3-CYCLE SHORT-CIRCUIT 600V (kA)	30-CYCLE <sup>1</sup> SHORT-TIME 600V (kA)
<b>UL 1008</b>		
800	100	85
1000	100	85
1200	100	85
1600	100	85
2000	100	85
2500	100	85
3000	100	85
3200	100	85
4000	100	...
<b>UL 891</b>		
4000	...	85 <sup>2</sup>
5000	...	85 <sup>2</sup>

<sup>1</sup> A Ratings used for coordination with upstream breakers with short-time ratings.  
<sup>2</sup> UL 1066 short-time withstand rating.

### 1.3 Magnum Fixed and Drawout Switching Devices

#### 1.3.1 General Magnum Switching Device

In a typical Magnum automatic transfer switch, the switching device is a Magnum power case switch. The magnum power case switch does not include an overcurrent trip. For specific applications like an integrated service entrance rated automatic transfer switch or an application where it is desirable to include overcurrent trips to the magnum device, a magnum breaker can be provided on either or both Source 1 and/or Source 2 device. In those cases the magnum device includes an overcurrent trip. The standard trip unit is a Digitrip 520. Optionally a digitrip 520M, 520MC, or 1150 can be provided.



Figure 5. The Magnum Fixed Switching Device.

The magnum power case switch can be provided in a standard fixed mounted design or an optional drawout design. Bypass isolation automatic transfer switches are provided with all drawout type designs. In addition the 4000A and 5000A designs come standard with drawout magnum power devices.



Figure 6. The Magnum Drawout Switching Device.

The Magnum transfer switches are available in the following configurations:

Table 2. Magnum Transfer Switch Configurations

NUMBER OF SWITCHING DEVICES	SWITCHING DEVICE TYPE
2	Fixed
2	Drawouts
4 (Bypass Isolation)	Drawouts

All Magnum switching devices are 100% rated, Underwriters Laboratories (UL) listed, and are built and tested in an ISO 9002 certified facility to applicable NEMA, ANSI, IEEE, and UL standards. For more information on Magnum switching devices, consult the Magnum switching device manual supplied with the transfer switch.

The main difference between the fixed and drawout versions of the Magnum switching devices used in the Magnum transfer switch is the mounting method. Fixed switching devices are bolted directly into the transfer switch frame while drawout switching devices are mounted in an extendable carriage within the transfer switch, allowing the switching device to be “drawn out” for service, maintenance, and/or replacement.



**Figure 7. Fixed Switching Device for the Magnum Transfer Switch.**



**Figure 9. Drawout Switching Device Fully Extended from the Magnum Transfer Switch.**

**1.3.3 Magnum Fixed Switching Devices**

The Magnum fixed type switching device differs from the drawout version in that it has no levering device, primary disconnects, and secondary disconnects.



**Figure 8. Drawout Switching Device Installed in the Magnum Transfer Switch.**

**1.3.2 Magnum Drawout Switching Devices**

The Magnum drawout switching device is a design having three positions with the compartment door closed (CONNECT, TEST, DISCONNECT) and one position out of its compartment on the extendable carriage rails (REMOVE). The Magnum drawout switching device is equipped with both primary and secondary disconnects to provide for the drawout functioning. The operating mechanism is a two-step, stored energy mechanism, either manually or electrically operated. When withdrawn on the extendable carriage rails, Magnum switching devices can be inspected, accessory items added, and minor maintenance performed. The inside of the compartment can also be inspected with the switching device withdrawn on the extendable carriage rails.



**Figure 10. Primary and Secondary Connections on a Magnum Fixed Switching Device.**

In addition, a fixed switching device does not have a standard feature to hold the switching device in a “trip-free” position.

Magnum fixed switching device terminals have holes for making bolted horizontal primary bus connections. Adapters are available for making vertical primary bus connections. Secondary connections can be made through standard terminal blocks or a special connector compatible with the drawout switching device’s type secondary connector. Both secondary connection devices are mounted at the top front of the switching device.

The Magnum fixed switching devices have two mounting feet, one on each side, to permit the switching device to be securely mounted to the transfer switch frame. Each mounting foot has two slotted mounting holes to facilitate mounting.

**1.4 Transfer Switch Catalog Number Identification**

Transfer switch equipment catalog numbers provide a significant amount of relevant information that pertains to a particular piece of equipment. The catalog number identification table (Table 3) provides the required interpretation information. An example for an open transition switch is offered to initially simplify the process.

**Example:** Catalog Number (circled numbers correspond to position headings in Table 3).

① to ②	③	④	⑤ to ⑥	⑦	⑧	⑨ to ⑫	⑬	⑭	⑮
AT	V	9	MG	B	3	3200	X	R	U

The catalog number ATV9MGB33200XRU describes an ATS with the switching devices mounted vertically in the enclosure. The intelligence, represented by the ATC-900, is a microprocessor-based logic package. The Magnum Breaker is used as the switching device and is a 3-pole power case breaker for each source. The continuous current rating of this equipment is 3200 A and is applicable at 480/277 Vac, 60 Hz. The transfer switch equipment is enclosed in a NEMA 3R enclosure and is listed for Underwriters Laboratories (UL) and Canadian Standards Association (CSA) applications.

**Table 3. Transfer Switch Catalog Number Explanation.**

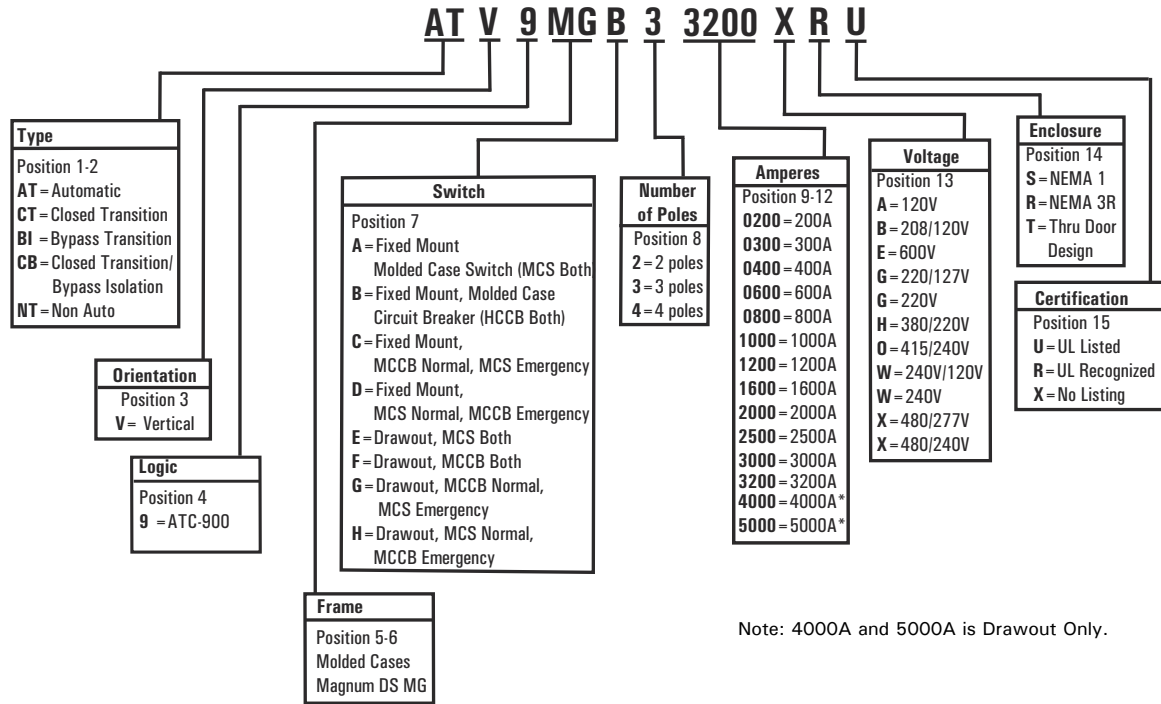

## Section 2: Receiving, Handling, and Storage

### 2.1 Receiving

Every effort is made to ensure that the transfer switch equipment arrives at its destination undamaged and ready for installation. Crating and packing is designed to protect internal components as well as the enclosure. Transfer switch enclosures are skid mounted and suited for fork lift movement. Care should be exercised, however, to protect the equipment from impact at all times. Do not remove the protective packaging until the equipment is at the installation location and ready for installation.

When the transfer switch equipment reaches its destination, the customer should inspect the shipping container for any obvious signs of rough handling and/or external damage incurred during transportation. Record any external and internal damage observed for reporting to the transportation carrier and Eaton, once a thorough inspection is completed. All claims should be as specific as possible and include the General Order numbers.

A shipping label is affixed to the top of the shipping container which includes a variety of equipment and customer information, such as General Order Number (GO #) and Catalog Number (Cat #). Make certain that this information matches other shipping paper information.

Each transfer switch enclosure is bolted to a rigid wooden pallet. The pallet is open at two ends for movement by a fork lift. The shipment is secured and further protected with shrink wrap. Do not discard the packing material until the equipment is ready for installation.

A plastic bag of documents will be found within the enclosure, usually attached to the inside of the door. Important documents, such as test reports, wiring diagrams, and appropriate instruction leaflets, are enclosed within the bag and should be filed in a safe place.

### 2.2 Handling

As previously mentioned, the transfer switch equipment is packaged for fork lift movement. Protect the equipment from impact at all times and DO NOT double stack. Once the equipment is at the installation location and ready for installation, the packaging material can be removed. Once the enclosure is unbolted from the wooden pallet, it can be installed using the lifting provision located on the top of the structure. Be careful not to damage the top or bottom enclosure mounting flanges. Refer to Section 4 of this manual for specific installation instructions.

### 2.3 Storage

Although well packaged, this equipment is not suitable for storage outdoors. The equipment warranty will not be applicable if there is evidence of outdoor storage. If the equipment is to be stored indoors for any period of time, it should be stored with its protective packaging material in place. Protect the equipment at all times from excessive moisture, construction dirt, corrosive conditions, and other contaminants.

It is strongly suggested that the package-protected equipment be stored in a climate controlled environment of -20° to 85°C (-4° to 185°F) with a relative humidity of 80% or less. DO NOT, under any circumstances, stack other equipment on top of a transfer switch equipment enclosure, whether packaged or not.

## Section 3: Equipment Description

### 3.1 General

This Eaton transfer switch equipment is available in three different configurations:

- ATS (Closed and Open transition);
- Non-Automatic (Electrically Operated) (Open Transition Only);
- Bypass Isolation Transfer Switch (Open and Closed Transition); and

Refer to Section 1 for a discussion of all three types. Each transfer switch is usually supplied in an enclosure, although unmounted sub-assemblies can be supplied for mounting by the customer. The enclosed ATS is the only specific type that will be discussed in this section.



**Figure 11. Typical Power Compartments (Open Transition Shown).**

The enclosed ATS consists of three basic panels interconnected through connector plugs and mounted in an enclosure:

- Power Compartments;
- Voltage Selection Panel; and
- Logic Panel

The components comprising the three panels are installed in accordance with the specific requirements of the circuit being controlled. Each transfer switch is, therefore, tailor-made to a specific application.

### 3.2 Power Compartments

The power compartment consists of a means for making load, power, and neutral connections. The main contacts and the transfer mechanism are all on one steel frame (Figure 12). The actual power connections are shown in Figure 13.



Figure 12. Power Case Switching Device.

#### 3.2.1 Main Contacts

The main contacts connect and disconnect the load to and from the different power sources. High withstand power case switches are the main contacts for the Source 1 and Source 2 power sources in standard, unmodified ATSS. Optional integral thermal and short circuit protection in either or both switching devices is available (Section 3.6). These continuous duty devices are rated for all classes of loads. In addition, they have high dielectric strength, heavy-duty switching and withstand capabilities, and high interrupting capacity.

#### 3.2.2 Switch Interlocks (Open Transition Only)

Eaton transfer switches are mechanically and electrically interlocked to prevent the two sets of main contacts from being closed simultaneously.

#### 3.2.3 Drawout Interlocks

The standard **closed transition** ATS is not provided with a mechanical interlock. All bypass switching devices are mechanically interlocked to the drawout mechanism to ensure that the switching device is always open when connecting or disconnecting it from the line and load stabs when in the bypass mode.

All **open transition** switching devices are mechanically interlocked to the drawout mechanism to ensure that the switching device is always open when connecting or disconnecting it from the line and load stabs.

The switching device will close only in the DISCONNECT, TEST, and CONNECT positions.

**3.2.4 TRANSFER MECHANISM**

The transfer switch uses Eaton Magnum power case switching devices and power case switches with a stored-energy mechanism. An electrical operator automatically recharges the mechanism after the switching device has been closed, and an indicator on the switch shows whether it is in the OPEN or CLOSED position and the status of the stored energy mechanism.

tion and the status of the stored energy mechanism.

The switching device is closed by energizing a solenoid that releases the spring mechanism. A shunt trip will open the switching device if energized.

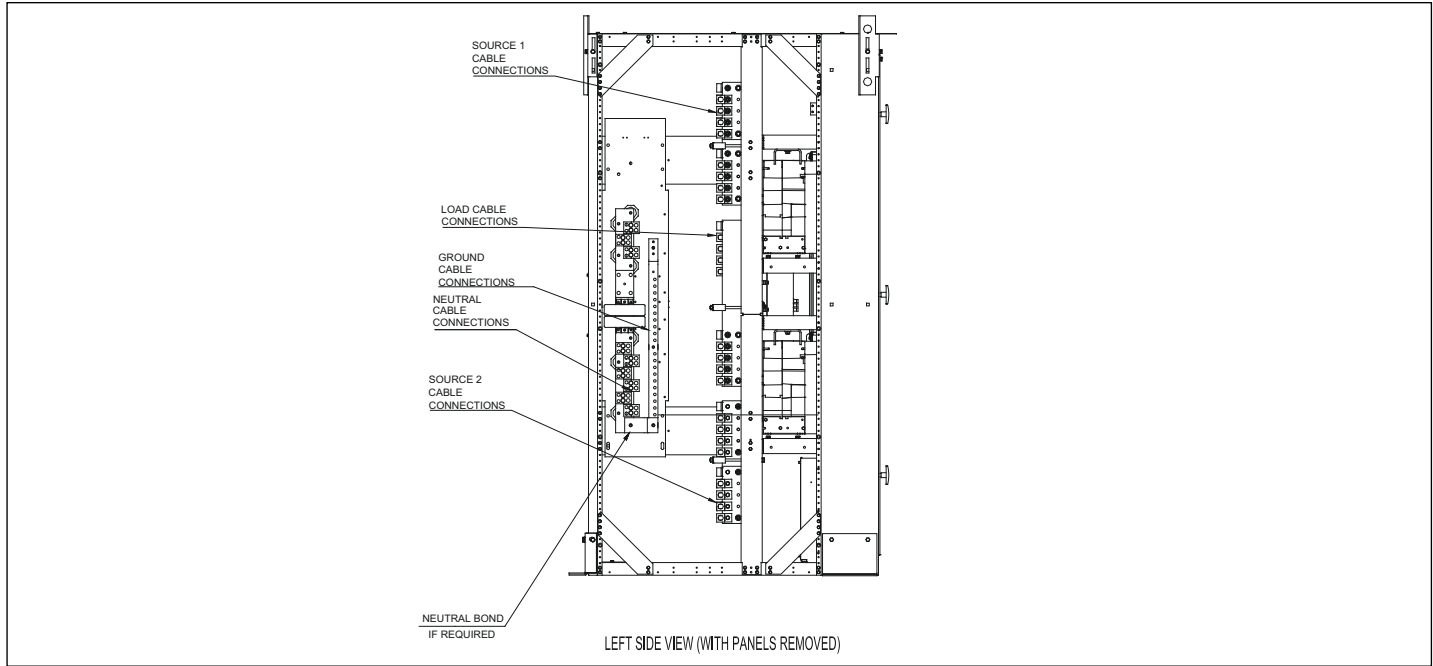

**Figure 13. Terminal Connections for a Typical Drawout Transfer Switch (800-3200A Closed Transition Shown).**

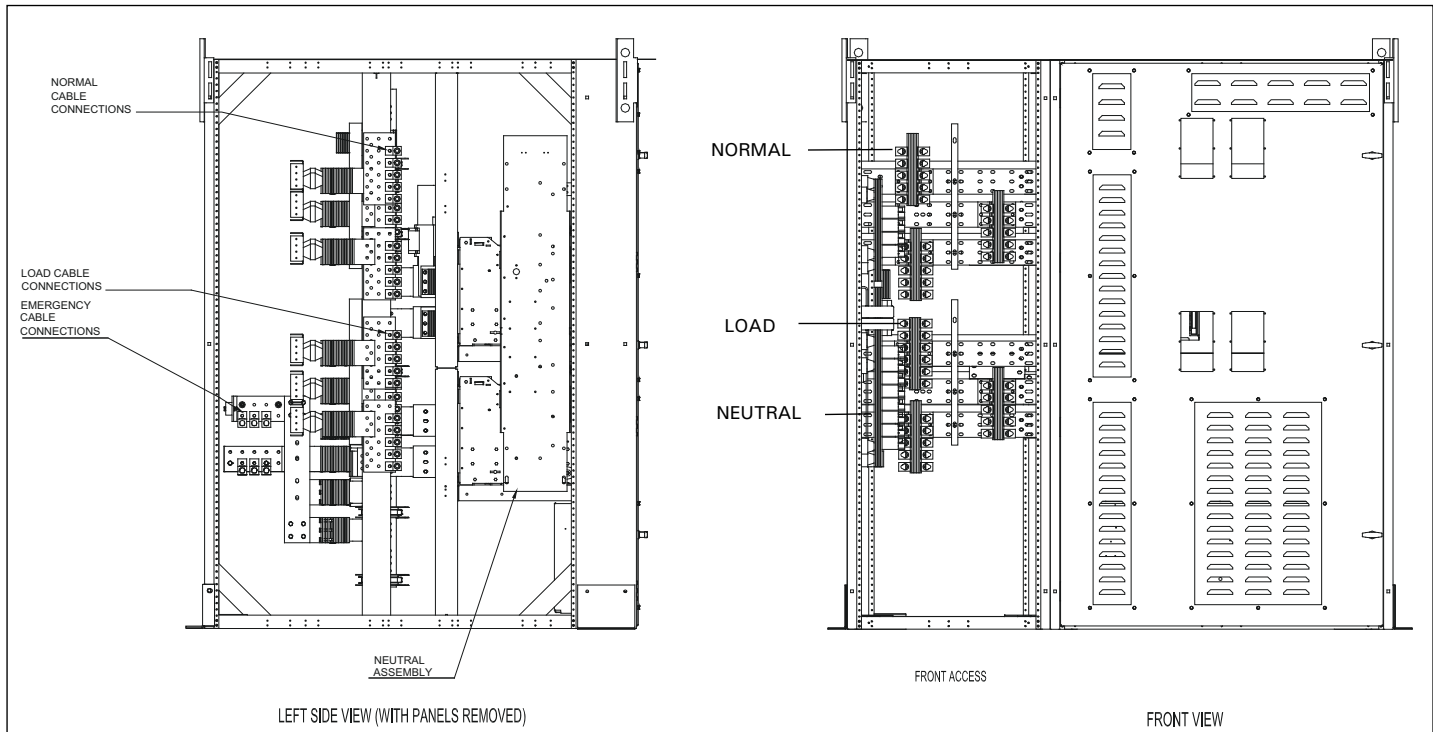

**Figure 13a. Terminal Connections for a Typical Drawout Transfer Switch (4000A Shown).**

**3.2.5 Drawout Mechanism**

The drawout mechanism is described in detail in Section 6 (Figure 14).



**Figure 14. Drawout Mechanism (Closed Transition Shown)**

**3.3 Voltage Selection Panel**

**3.3.1 Voltage Selection Connectors (208, 220, 240, 380, 415, 480, and 600 Vac, 50/60 Hz)**

The voltage selection panel consists of multi-tap transformers, contained in a steel case mounted in the transfer switch enclosure (Figure 15). It is mounted at the bottom panel of the switch. The cover has “teardrop” holes for the screws to allow easy access to the transformers. The voltage is selected by simply removing the connector and reconnecting to the desired voltage. (The ATC-900) setpoints will have to be changed to the voltage selected). If the connectors are not on the outside, the switch is older than November of 2014. Taps are available to switch out, see section 4.6 for instructions. Taps are provided for 208, 240, 480, 600 for North America and 220, 380, 415 for International voltages. Figure 16 shows the two transformers inside the enclosure Line Replaceable Unit (LRU), one for Source 1 and the other for Source 2, Vac to satisfy most voltage requirements. The factory default position is the voltage tap based on customer voltage specification.



**Figure 15. Voltage Selection Panel**

**⚠ WARNING**

**WHEN CHANGING THE SELECTED VOLTAGE, THE POWER MUST BE REMOVED FROM THE TRANSFER SWITCH AND THE WIRES MUST BE MOVED ON THE TAPS OF BOTH TRANSFORMERS.**



**Figure 16. Power Transformers (Source1 & Source 2).**

**3.4 Logic Panel**

The logic panel provides the intelligence and supervisory circuits which constantly monitor the condition of both the Source 1 and Source 2 power sources, thus providing the required intelligence for transfer operations (Figure 17). Detailed information is presented in a separate document:

- ATC-900 Instruction Book IB140012EN

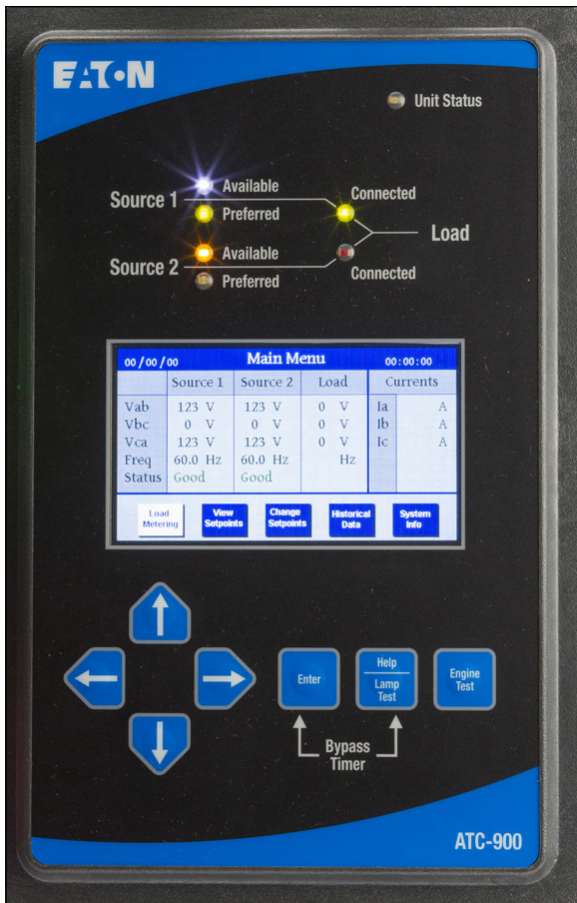

Figure 17. ATC-900.

### 3.5 Neutrals

All 2-pole and 3-pole transfer switches are equipped with 100% rated neutral connections (Figures 18 and 19). Different lug configurations are available (See Option 21A).

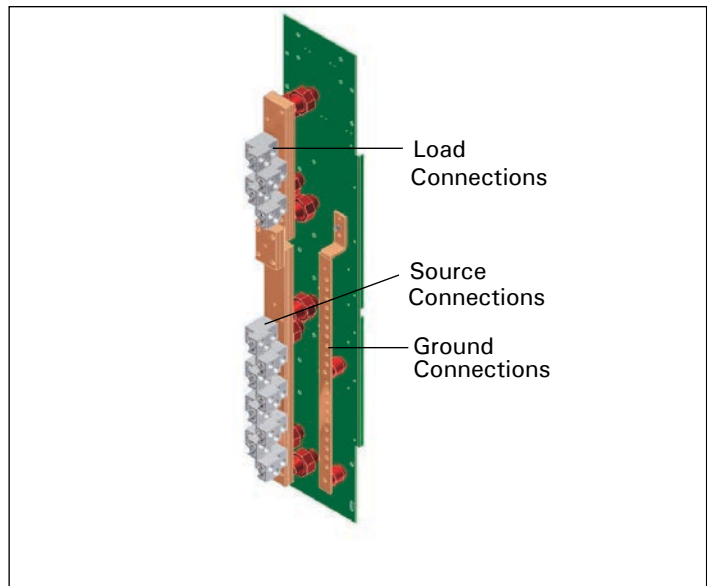

Figure 19. Solid Neutral.

### 3.6 Features

Switch options, which are not part of the logic scheme, are available to meet a variety of other application requirements. Options are numbered with an associated description. More detailed selections, which must be made within a specific option number, are identified by letters. For available options associated with the logic scheme, refer to the specific logic document associated with the type of logic selected.

The ATC-900 has many features that are available to the user. These features are standard and are available. Appendix A of the ATC-900 IB, has a list of all of the features including any acronyms used along with a brief description. The feature numbers corresponds to the internal codes and some of these numbers may be on the product drawings. Also see Table 5 "ATC-900 Features" for a compact list. Table 5 also includes an Inputs/Output full list with Appendix B showing the I/O descriptions.

Some of the features will have to be hard coded into a certain I/O position which cannot be changed by the user. An example of this would be Service Entrance; the Go To Neutral would be a fixed input. The programmable I/Os are covered in Section 5. The only item that is optional for the transfer switch is the closed transition optional feature. The closed transition is covered in section 1.5.3 of the ATC-900 IB

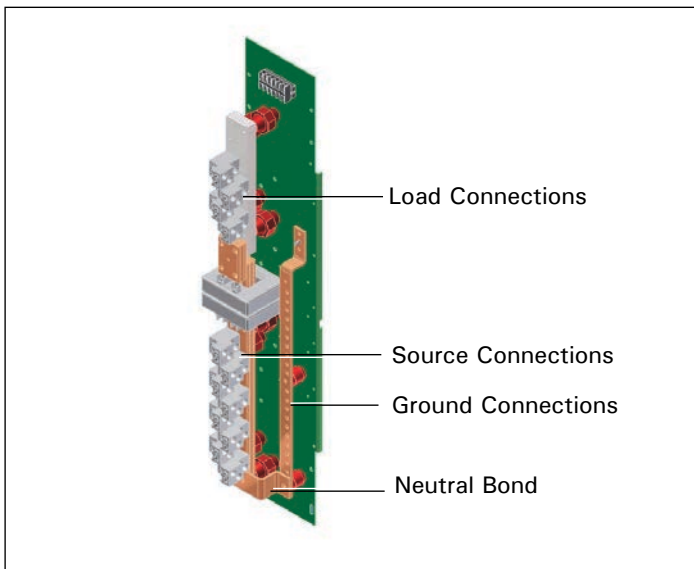

Figure 18. Neutral SE with Ground Fault.

#### NOTICE

OPTIONS ARE UL LISTED, EXCEPT AS NOTED, WHEN SUPPLIED ON UL LISTED SWITCHES. IF AN OPTION IS SELECTED WHICH IS NOT UL LISTED, THE SWITCH WILL NOT HAVE A UL LABEL.

#### NOTICE

NOT ALL OPTIONS ARE AVAILABLE FOR ALL TRANSFER SWITCH CONFIGURATIONS. IF IN DOUBT, CHECK PRICE LIST 29-920 FOR THE AVAILABILITY OF OPTIONS FOR A SPECIFIC TRANSFER SWITCH DESIGN. THE OPTION NUMBERS USED HERE CORRESPOND TO THE NUMBERS USED IN THE PRICE LIST.

The following are some of the more popular options that can be used on the Magnum Switch. There are several others which are shown in the ATC-900 instruction booklet.

### 9B. Maintenance Selector Switch (MSS)

Provides a 2-position, maintained contact selector switch marked "Operate" and "Disable." When the MSS is placed in the "Disable" position, the controller logic will be disconnected from the transfer motor circuit. The MSS is placed in the "Operate" position for normal automatic operation.

### 29G. Automatic/Manual Operation With Selector Switch

Provides 2-position selector switch (labeled Auto/manual) that permits selection of the automatic or manual transfer. When in the "Auto" position, the transfer switch operates with fully automatic transfer, retransfer and generator startup and shutdown operations. When in the "Manual" position, manual operation is required to initiate the generator startup or retransfer with generator shutdown operations.

**Note:** Transfer switches with **Feature 29** must have a white light lit when the switch is not in the automatic switch mode.

### 37. Service Equipment Rated Transfer Switch

Provides the label "suitable for use as service equipment" and the features necessary to meet the requirements for the label. Includes service disconnect with visible indication and neutral assembly with removable link. **Feature 16B or 16N** must be selected separately.

#### 37A. Service Equipment Rated

Transfer Switch Without Ground Fault Protection Provides service equipment rating for an application that does not require ground fault protection.

#### 37B. Service Equipment Rated Transfer Switch With Ground Fault Protection

Provides service equipment rating for an application that requires ground fault protection.

### 38. Steel Cover

Provides protection for a device panel as option 38a and protection for the controller as option 38b.

### 41E. Space Heater With Thermostat

Provides 1 100 or 375-watt space heater. A separate transformer is provided for the 375 watt heater and it is located on the top shelf of the switch.

### CVX

The CVX device features a Thermally Protected Metal Oxide Varistor technology and comes with high intensity LED phase status indicators.

### SPD

The SPD features a Thermally Protected Metal Oxide Varistor technology. It comes with dual-colored protection status indicators for each phase and for neutral-ground protection mode. It comes with an audible alarm with silence button and a Form C contact. An optional SPD with surge counter feature package is available. This provides six-digit surge counter with reset button.

## 3.7 Enclosure

The rugged steel switch enclosure is supplied with four door hinges, regardless of enclosure size, to insure proper support of the door and door mounted devices. The hinges have removable hinge pins to facilitate door removal. The doors are supplied as standard with thumbscrew and padlock latches. Cable entry holes are the customer's responsibility.

The door is used to mount a variety of lights, switches, and push buttons, depending upon the options required for a particular switch. All switch doors are supplied with a heavy duty plastic accessory panel in place, whether or not external devices are required. When lights, pushbuttons, or switches are required, they are normally mounted in the plastic door mounted panel.

Transfer switch enclosures and some internal steel mounting plates, such as the transformer panel mounting plate, go through a pre-treatment cleaning system prior to painting to insure a durable finish. Should the enclosure become scratched and in need of touch up paint, use ANSI 61. All remaining steel is galvanized.

The standard switch enclosure is NEMA Type 1 for general indoor use (Table 4).

**Table 4. Transfer Switch Equipment Enclosures.**

NEMA TYPE	DESIGN	PROTECTION
1	Indoor	Enclosed Equipment
3R	Outdoor	Rain, Ice Formation

## 3.8 Standards

Eaton transfer switch equipment is listed for application by UL and CSA. In addition, Eaton ATs are listed in File E38116 by UL, Inc., under Standard UL 1008. This standard covers requirements for ATs intended for use in ordinary locations to provide for lighting and power as follows:

- In emergency systems, in accordance with articles 517 and 700 in the National Electrical Code (NEC), American National Standards Institute/National Fire Protection Association (ANSI/NFPA) 70 and the NFPA No. 76A and/or
- In stand-by systems, in accordance with article 702 of the NEC and/or
- In legally required stand-by systems in accordance with article 701 of the NEC.
- In critical operations power systems (COPS article 708) in accordance with article 708 of the NEC

Eaton ATs are available to meet NFPA 110 for emergency and stand-by power systems, and NFPA 99 for health care facilities when ordered with the appropriate options.

Since Eaton ATs utilize specially designed switches and/or switching devices as the main power switching contacts, these devices must also be listed under the additional UL Standard 1066. UL utilizes two basic types of listing programs: a) Label Service and b) Re-examination. UL1066 employs a label service listing program which requires an extensive follow-up testing program for listed devices. Standard UL1008 for ATs lists devices under the re-examination program which only requires a continual physical re-examination of the components used in the product to insure consistency with the originally submitted device. Follow-up testing IS NOT required by UL1008.

Representative production samples of switches and switching devices used in Eaton ATs are subjected to a complete test program identical to the originally submitted devices on an ongoing periodic basis per UL1066. The frequency of such a re-submittal can be as often as every quarter for a low ampere device.

## Section 4: Installation and Wiring

### 4.1 General

Eaton transfer switches are factory wired and tested. Installation requires solidly mounting the enclosed unit and connecting the power cables and auxiliary pilot circuits. Physical mounting procedures and power cable connections are covered in this section. All other required wiring or electrical connection references are covered in a separate **Customer Wiring Diagram** packaged with the transfer switch.

Locate the wiring booklet, review it, and keep it readily available for reference purposes during installation and testing. Once a transfer switch is properly installed and wired, it should be mechanically and electrically checked for proper installation and operation. The procedures for these initial mechanical and electrical checks are outlined in Section 8.1 of this instruction manual.

### WARNING

**BE CERTAIN THAT THE SOLID STEEL DEAD FRONT SHIELDS ARE PROPERLY INSTALLED BEFORE THE TRANSFER SWITCH EQUIPMENT IS PUT INTO SERVICE. THE SHIELD PROVIDES PROTECTION FROM DANGEROUS VOLTAGES AT THE LINE AND LOAD TERMINALS WHEN THE EQUIPMENT IS IN OPERATION. FAILURE TO DO SO COULD RESULT IN PERSONAL INJURY OR DEATH.**

### 4.2 Mounting Location

Choose a location that offers a flat, rigid mounting surface capable of supporting the weight of the enclosed transfer switch equipment. Avoid locations that are moist, hot, or dusty. However, Eaton offers enclosure designs that can be used in special environments. If there are any doubts as to the suitability of the location, discuss it with your Eaton representative.

Check to make certain that there are no pipes, wires, or other hazards in the immediate area that could create a problem. The panels provide ample room for rear cable entry from top, bottom, and sides. At no time should cable be routed to retard the action of relays or cover the logic in a way that restricts adjustments. Maintain proper electrical clearances between live metal parts and grounded metal.

For installation and maintenance purposes, the Source 1 and Source 2 power sources must have an overcurrent protective device upstream of the transfer switch, unless overcurrent protection is integral to the switch.

The dimensions of the transfer switch are an important consideration in determining proper location selection.

### 4.3 Unpackaging and Inspection

#### CAUTION

**SINCE THE ENCLOSED TRANSFER SWITCH MUST BE LIFTED INTO PLACE FOR MOUNTING, BE CERTAIN THAT ADEQUATE RESOURCES ARE AVAILABLE FOR LIFTING TO AVOID PERSONNEL INJURIES OR EQUIPMENT DAMAGE.**

Proceed with the following four steps:

- Step 1:** Carefully uncrate the transfer switch. If damage is visible, please contact your local Eaton sales representative or the factory.
- Step 2:** Open the door and visually verify that there are no broken or damaged components or evidence of distorted metal or loose wires as a result of rough handling.
- Step 3:** A label on the door provides specifications for your transfer switch. Verify that these specifications comply with your requirements.
- Step 4:** Remove any braces or packing used to protect the transfer switch or internal components during shipping.

#### CAUTION

**EXTREME CARE SHOULD BE TAKEN TO PROTECT THE TRANSFER SWITCH FROM DRILL CHIPS, FILLINGS, AND OTHER CONTAMINANTS WHEN MAKING THE CABLE ENTRY HOLES AND MOUNTING THE ENCLOSURE TO PREVENT COMPONENT DAMAGE OR A FUTURE MALFUNCTION.**

**4.4 Mounting Procedure**

**NOTICE**

**CABLE ENTRY HOLES ARE NOT PART OF THE ENCLOSURE WHEN SHIPPED FROM THE FACTORY AND MUST BE PROVIDED IN THE FIELD, EITHER BEFORE OR AFTER MOUNTING THE ENCLOSURE.**

With the enclosed transfer switch equipment unpacked and ready for mounting, proceed with the following steps:

- Step 1:** Mounting and cabling access is best provided by removing side and rear covers (when applicable). See Section 9.3 for cover removal instructions.
- Step 2:** Gently maneuver the switch into its location using all of the supplied lift brackets.
- Step 3:** Bolt the enclosure to the base. Use separate cleats (Option 42 only) if Seismic Uniform Building Code (UBC) Zone 4 certification is desired (Figure 20), and secure with 1/2-13 UNC Grade 5 hex bolts. Seismic per IBC 2009, CBC2010, OSHPD OSP-0014-10 (3200 A and below). See the Outline drawing (xxxx.O001) for specific mounting areas for the switch as well as the Bypass type switch.
- Step 4:** Tighten bolts to 50 ft-lbs (68 Nm).
- Step 5:** Double check to ensure that all packing and shipping material has been removed

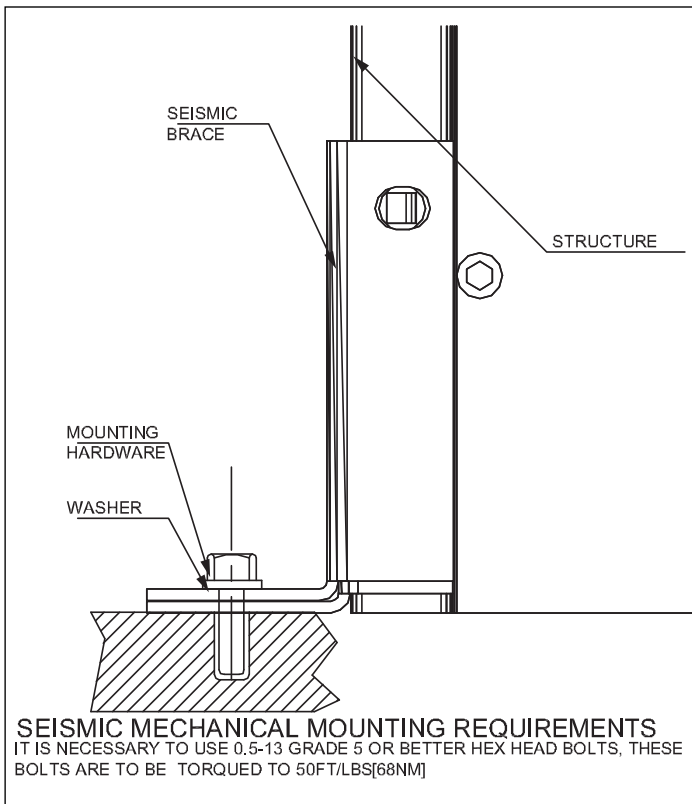

**Figure 20. Seismic Tested and Approved Product Mounting Instructions.**

**4.5 Power Cable Connections**

**WARNING**

**POWER CONDUCTORS MAY HAVE VOLTAGE PRESENT THAT CAN CAUSE SEVERE PERSONAL INJURY OR DEATH. DE-ENERGIZE ALL POWER OR CONTROL CIRCUIT CONDUCTORS TO BE CONNECTED TO THE TRANSFER SWITCH EQUIPMENT BEFORE BEGINNING TO WORK WITH THE CONDUCTORS AND/OR TERMINATING THEM TO THE EQUIPMENT.**

**CAUTION**

**USE OF CABLE LUGS NOT DESIGNED FOR THE TRANSFER SWITCH APPLICATIONS MAY CAUSE HEATING PROBLEMS. BREAKER LUGS ONLY MOUNT TO THE BREAKER, WHILE TRANSFER SWITCH LUGS MOUNT TO BOTH THE BREAKER AND THE BUS BAR BEHIND THE BREAKER. FOR INSTALLATION INSTRUCTIONS, REFER TO THE INSTRUCTION LEAFLET SUPPLIED FOR THE SPECIFIC LUGS.**

**CAUTION**

**TO HELP PREVENT COMPONENT DAMAGE OR FUTURE MALFUNCTIONS, USE EXTREME CARE TO KEEP CONTAMINANTS OUT OF THE TRANSFER SWITCH EQUIPMENT WHEN MAKING POWER CABLE CONNECTIONS.**

**CAUTION**

**RUN THE POWER CABLE THROUGH THE GUTTER SPACE PROVIDED IN THE REAR OF POWER COMPARTMENTS.**

Test all power cables prior to connection to the unit to ensure that the conductors or cable insulation have not been damaged while being pulled into position.

Power cables are to be connected to solderless screw type lugs located on the ATS switching devices. Refer to the separate customer wiring diagram supplied with the ATS equipment for power termination. Verify that the lugs supplied will accommodate the power cables being used. Also verify that the cables comply with local electrical codes. Standard ATS equipment, as supplied from the factory, will accommodate the wire sizes shown in Table 5.

Carefully strip the insulation from the power cables to avoid nicking or ringing of the conductor strands. Prepare the stripped conductor termination end by cleaning it with a wire brush. If aluminum conductors are used, apply an appropriate joint compound to the clean conductor surface area.

Wrap line cables together with nominal 3/8 inch nylon rope or rope having tensile strength of 2,000 pounds.

Wrap at 4 inches and 15 inches from the line terminals with 8 and 18 wraps respectively or every 1 inch with 1 wrap.

Repeat the above for the load cables.

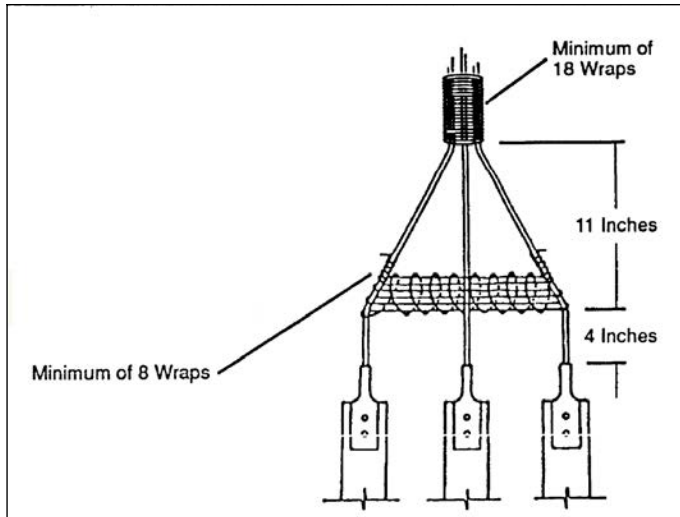

Figure 21. Cable Bracing Instructions.

**CAUTION**

**IMPROPER POWER CABLE CONNECTIONS CAN CAUSE EXCESSIVE HEAT AND SUBSEQUENT EQUIPMENT FAILURE.**

Tighten the cable lugs to the torque identified on the label affixed to the door.

Proceed with the following steps:

- Step 1:** Verify that the line and load cables comply with applicable electrical codes.
- Step 2:** Verify that the transfer switch rated current and voltage (see identification plate on the door of the transfer switch) agree with system current and voltage.
- Step 3:** After the transfer switch is mounted, provide the conduit or cable openings as required. Ensure that no metal filings contaminate the transfer switch components.
- Step 4:** Test all power cables before connecting them to the unit to insure that the conductors or the cable insulation have not been damaged while being pulled into position.
- Step 5:** Carefully strip the insulation from the power cables. Avoid nicking or ringing of the conductor strands. Prepare the stripped conductor termination end by cleaning it with a wire brush. If aluminum conductors are used, apply an appropriate joint compound to the clean conductor surface area. Refer to Figure 13 for the approximate locations of the power connections.

**Table 5. Wire Size for Available Power Cable Connections.**

DEVICE	SWITCH RATING (AMPS)	CABLES PER PHASE	RANGE WIRING SIZE
Switch	800-2000	6	3/0-750 MCM
Switch	2500-3200	9	3/0-750 MCM
Switch	4000	10	3/0-750 MCM
Switch	5000	12	3/0-750 MCM
Neutral	800-2000	24	4/0-500 MCM
Neutral	2500-3200	36	4/0-500 MCM
Neutral	4000	48	4/0-500 MCM
Neutral	5000	48	4/0-500 MCM

- Step 6:** Make the necessary connections of any options using the wiring diagrams supplied with the unit.
- Step 7:** Connect the engine start wires to the Red Terminal blocks for S2 Generator Start located in the bottom panel.

**4.6 Voltage Selection Adjustment (Non-Connector)**

Certain devices, such as the voltage selection panel, sensing relays, and timers need to be set and/or calibrated prior to placing the transfer switch equipment into service. Adjustments for logic devices are described in the separate instructional document dedicated to the specific logic being used. Voltage selection adjustments are described here. For newer switches (Nov 2014) there is a voltage selection connector. Please see section 3.3.1 for the voltage selection types. If the voltage selection is not on the front of the transformer using a connector, then one would need to

open the transformer and move the physical tap connectors. The following is how to change the taps.

Voltage selection is made at the multi-tap transformer subassembly (see Figures 22, 22A, and 22B) mounted in the lower compartment of the transfer switch. This subassembly includes two identical control power transformers with one connected to Source 1(NT1) and the other connected to Source 2 (ET1). The control power transformers are mounted behind a removable panel (see Figure 22B).

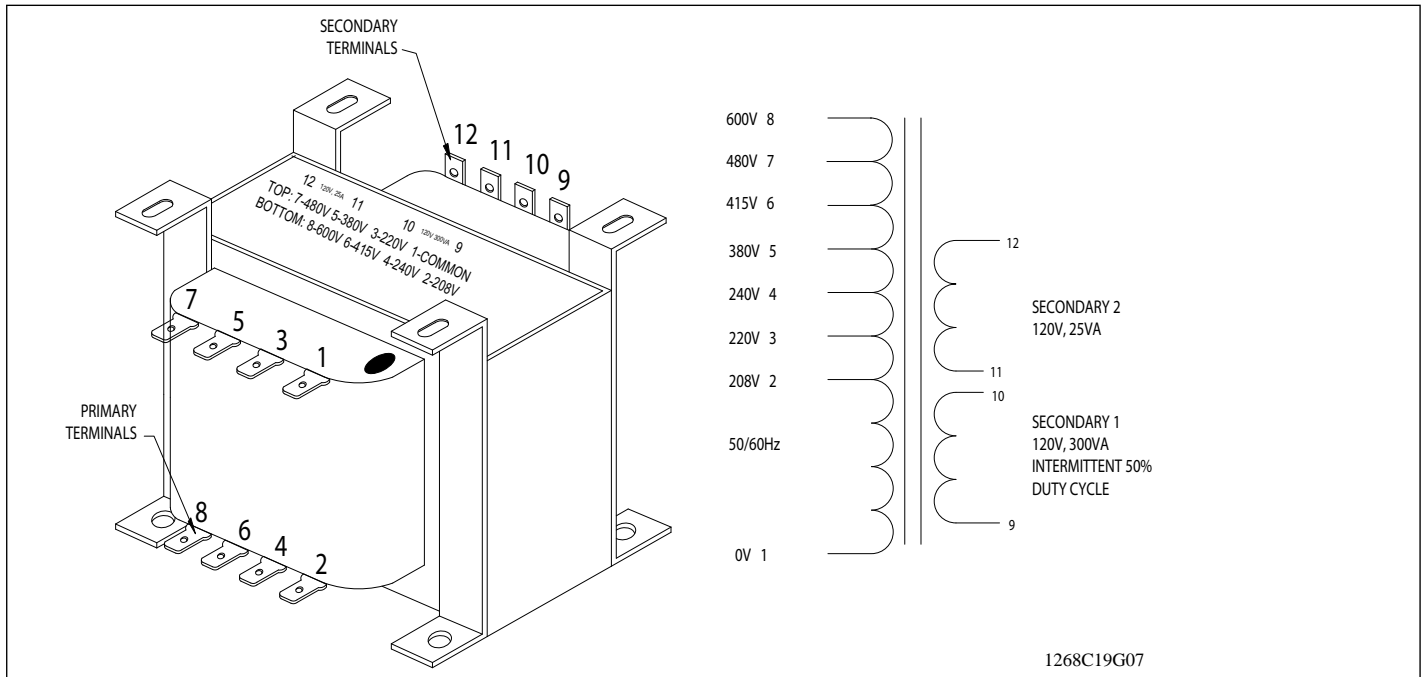

**Figure 22. Transformer and Taps.**



**Figure 22A.**

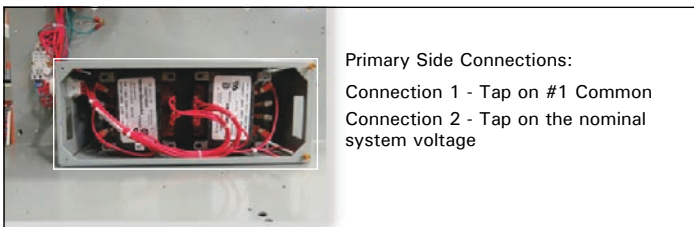

**Figure 22B.**

**⚠ WARNING**

**DISCONNECT ALL SOURCES OF POWER OR DISCONNECT P7/S7 PRIOR TO PERFORMING THE FOLLOWING. FAILURE TO DO SO MAY CAUSE SERIOUS INJURY OR DEATH.**

- Remove the transformer pack cover by loosening the 4 screws located at each corner of the transformer pack assembly.
- The transformers are factory set on the voltage tap specified by the customer. (See illustration above for location of various taps and voltages)
- Detach the spade connector from the existing voltage tap and place on the tap that is suitable for your application.

**⚠ CAUTION**

**BE SURE THAT THE CORRECT VOLTAGE IS SELECTED TO MATCH THE SYSTEM VOLTAGE. AN IMPROPER SELECTION AND/OR CONNECTION COULD RESULT IN EQUIPMENT DAMAGE.**

- After changing the taps on both transformers, replace the transformer pack cover and tighten all four screws.

**4.7 Control Wiring to Magnum Power Case Switch/ Breaker**

Control connections to the magnum power case switch can be made to the terminal blocks mounted above each device. The dead front needs to be removed first to gain access to the terminal locations. Typically the Source 1 (Normal) is the upper power device and Source 2 (Emergency) is the lower power device. The terminals are numbered the same for each one and also the same for fixed mounted or drawout designs. An example of the auxiliary contacts is shown in typical drawing below.

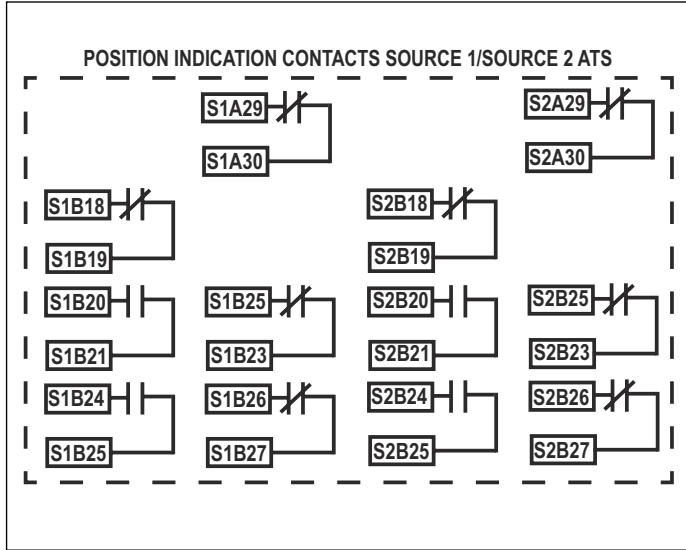

**4.8 Wiring**

**CAUTION**

**POWER CONDUCTORS AND CONTROL WIRING MAY HAVE VOLTAGE PRESENT THAT CAN CAUSE SEVERE PERSONAL INJURY OR DEATH. DE-ENERGIZE ALL POWER OR CONTROL CIRCUIT CONDUCTORS BEFORE BEGINNING TO PERFORM ANY WIRING ACTIVITY TO OR WITHIN THE TRANSFER SWITCH EQUIPMENT.**

Power sources, load conductors, and control wiring should be connected to locations as indicated in the **Customer Wiring Diagrams** supplied with the transfer switch equipment.

**4.8.1 Engine Start Connection**

The engine control contact connections are located on the bottom area of the switch at a terminal block and are Red. All customer connections are located there. The S2 generator start's terminal blocks are red in color

**Note:** Prior to making the engine start connection to the switch on bypass isolation units, set the engine generator controls selector switch in the OFF position to prevent an unwanted engine start. A contact closes between these terminal blocks when an engine start signal is provided by the ATS logic.

**4.8.2 ALARM CONTACTS (CLOSED TRANSITION ONLY)**

**Closed transition only** ATSS are provided with an extra shunt trip on the Source 1 device. This shunt trip is energized when the Time Delay Utility Parallel (TDUP) times out (preset by user), thus opening the source device. The TDUP timer starts timing when both sources are paralleled. Refer to the IQ Transfer instruction book for additional alarms.

**4.8.3 I/O Contact Terminal Blocks**

All customer connections are located on the bottom of the switch to terminal blocks. As shown in the ATC-900 Instruction Booklet, there are 4 in and 4 out available programmable I/Os from the controller. These are wired out from the ATC-900 to terminal blocks for easier access. With I/O Modules, there could be up to 20 in and 20 out (Form C) available. Some I/O may be fixed depending on the options chosen i.e. service entrance needs Go to Neutral so that input would be fixed. See Figure 15a. Below is a list of the I/O signals and other signal terminal blocks.

Inputs	TBJ9 1-8
Outputs	TBJ4 7-18
Gen Start 1	TBJ15 1-3
Gen Start 2 (red)	TBJ15 4-6
Source 1 Available	TBJ4 1-3
Source 2 Available	TBJ4 4-6

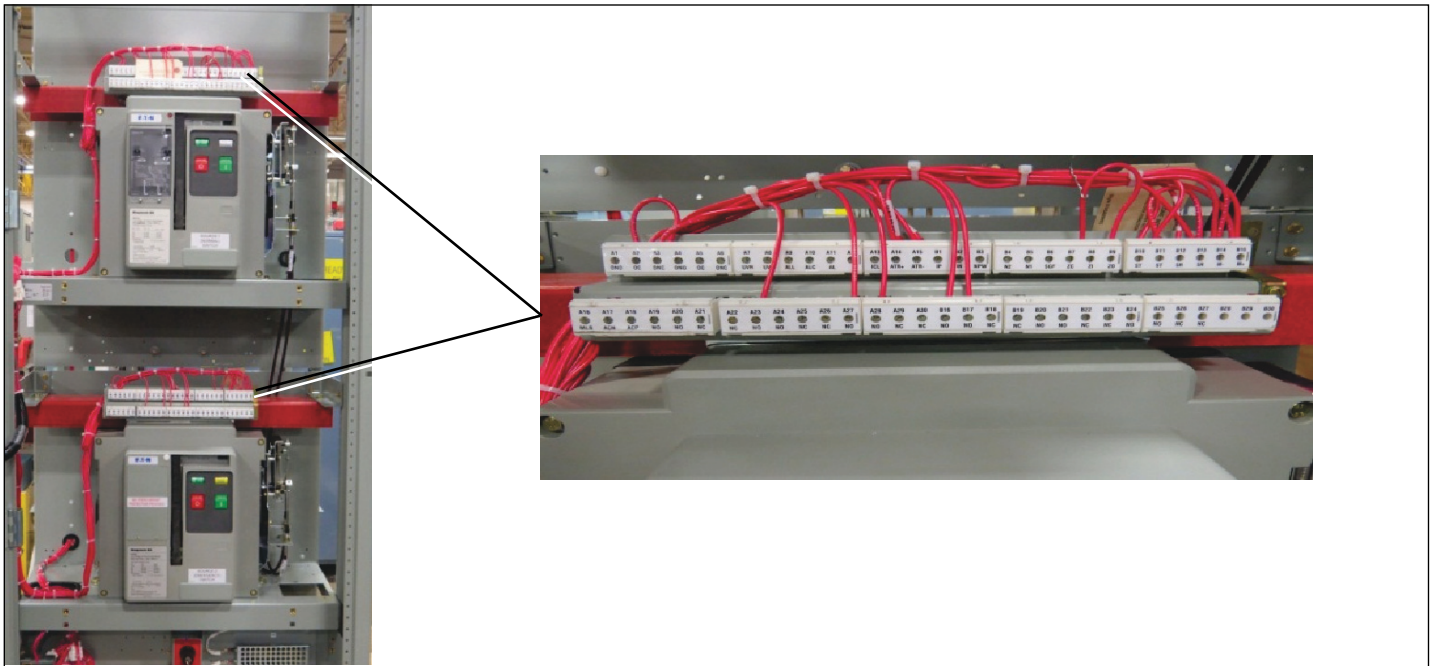

**Figure 23. Terminal Blocks Mounted Above Each Device.**

## Section 5: Operation

### 5.1 General

#### WARNING

THE CLOSED TRANSITION PRODUCT CONTAINS A SPECIAL CONTACT ARRANGEMENT (OVERLAPPING CONTACTS). MISUSE CAN RESULT IN DEATH, SEVERE PERSONAL INJURY, AND/OR PROPERTY DAMAGE.

A transfer switch provides main contacts to connect and disconnect the load to and from the Source 1 and Source 2 power sources. A stored-energy type transfer mechanism provides the mechanical motion required to open and close the main contacts (Paragraph 3.2.1).

Each switch can be manually operated. Before a switching device can be closed, the stored energy mechanism must be charged by pumping the handle (Figure 24).



Figure 24. Pumping Handle Charges Stored Energy Mechanism (Closed Transition Shown).

In the **closed transition product**, a single switching device can be manually closed by following the instructions detailed in Figure 26. An indicator window shows whether the switch is open or closed.

The open transition switching device can be closed by pushing the close button (Figure 25). The other switching device is prevented from closing through a rigid mechanical interlock (Paragraph 3.2.2). An indicator window shows whether the switch is open or closed.



Figure 25. Close Switch by Pushing Close Button.

#### NOTICE

IF A TRANSFER SWITCH WITH ANY TYPE OF ELECTRICAL OPERATING CAPABILITIES IS TO BE OPERATED MANUALLY UTILIZING THE MANUAL OPERATING HANDLE, IT IS STRONGLY RECOMMENDED THAT THE TRANSFER CONTROL CIRCUIT FIRST BE ISOLATED. THIS IS ACCOMPLISHED BY DISCONNECTING THE S7/P7 PLUG ON THE TRANSFORMER PANEL. AN AUTOMATIC ENGINE START WILL OCCUR UNLESS THE GENERATOR RUN SWITCH SET TO "OFF." IF, HOWEVER, A TRANSFER SWITCH IS SUPPLIED WITH A FOUR-POSITION SELECTOR SWITCH (OPTION 6H), IT CAN BE TURNED TO THE OFF POSITION, MAKING IT UNNECESSARY TO UNPLUG THE LOGIC. IN THE CASE OF THE ATS DESIGN, ANY ATTEMPT TO OPERATE THE MANUAL HANDLE WITHOUT FIRST ISOLATING THE CONTROL CIRCUIT CAUSES AN AUTOMATIC TRANSFER.

### 5.2 Automatic Transfer Switch

The operating sequence of an ATS is dictated by the switch's standard features and selected options. Operation of an ATS during Source 1 power source failure, Source 1 power source restoration, and testing is described in the associated Controller Instruction Booklet.

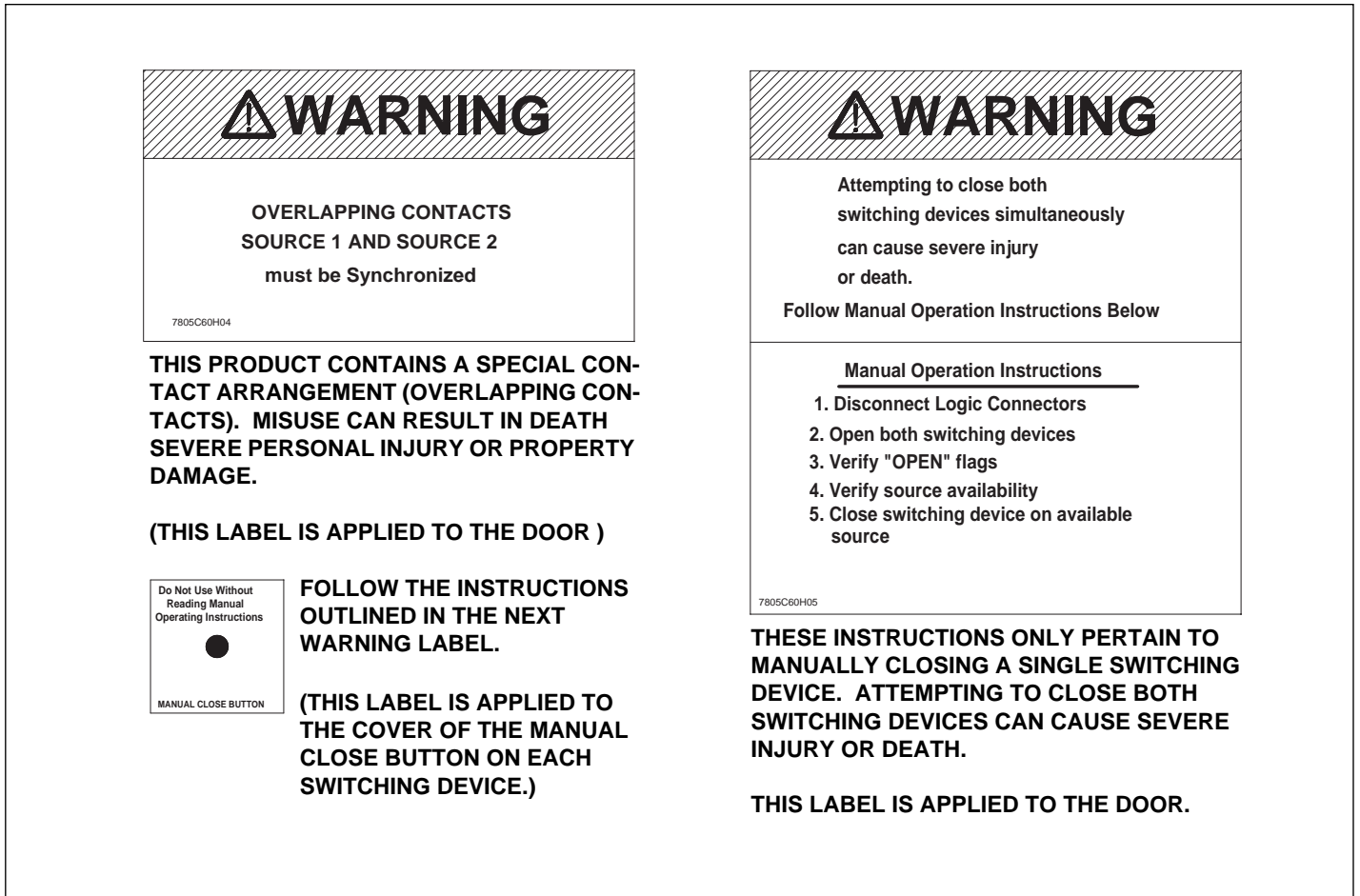

**Figure 26. Switching Device Closing Precautions (Closed Transition Only).**

## Section 6: Drawout and Fixed Switching Devices

### 6.1 Installing a Drawout Switching Device

In transfer switches equipped with drawout switching devices, bolted-in carriages with extendable rails support the switching devices.



Figure 27. Switching Device Drawn Out from the Transfer Switch.

To install a drawout switching device, the extendable rails must first be pulled all the way out. Once the rails are fully extended, the switching device can be carefully placed on the rails.

#### CAUTION

**IT IS IMPORTANT TO TAKE GREAT CARE WHEN PLACING A DRAWOUT SWITCHING DEVICE ON ITS EXTENDED RAILS. IF THE SWITCHING DEVICE IS NOT PROPERLY SEATED ON THE EXTENDABLE RAILS, IT COULD FALL FROM THE RAILS CAUSING EQUIPMENT DAMAGE AND/OR BODILY INJURY.**

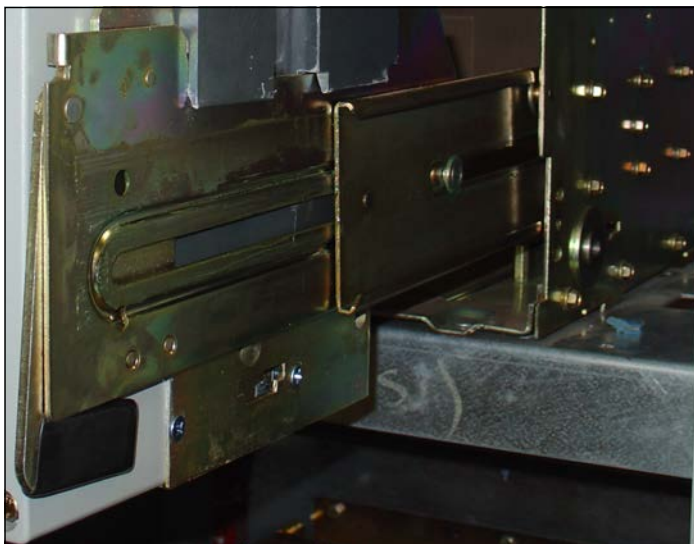

Figure 28. Drawout Rail Supports Fully Seated in the Rail Cutouts.

Carefully lower the switching device onto the extended rails. Be certain that the switching device's four molded drawout rail supports are fully seated in the extendable rail cutouts on both sides (Figure 29). **Do not remove the lifting yoke from the switching device until it is properly seated on the rails.**



Figure 29. Switching Device in the REMOVE Position.

Once the switching device is properly seated on the extended rails, the lifting yoke can be removed and the rest of the switching device installation procedure can be completed.

#### 6.1.1 Switching Device Positioning

The Magnum drawout switching device has four normal positions:

- REMOVE (Withdrawn) (Figure 29)
- DISCONNECT (Figure 32)
- TEST (Figure 31)
- CONNECT (Figure 30)

The REMOVE position is a position outside the compartment on the carriage's drawout rails where the switching device is not engaged with the levering mechanism. The DISCONNECT, TEST, and CONNECT, positions are reached by means of the levering mechanism.

With the switching device solidly positioned on the carriage's extendable rails and the levering-in mechanism in the DISCONNECT position, carefully and firmly push the switching device into the compartment as far as it will go. The outer (recessed) portion of the switching device face plate should align with the GREEN target line (labeled DISC) on the inside top left wall of the carriage (Figure 33).

#### CAUTION

**MAKE CERTAIN THAT THE SWITCHING DEVICE IS FULLY INSERTED INTO ITS COMPARTMENT BEFORE ANY ATTEMPT IS MADE TO LEVER THE SWITCHING DEVICE. ATTEMPTING TO LEVER THE SWITCHING DEVICE IN BEFORE IT IS FULLY POSITIONED INSIDE ITS COMPARTMENT CAN RESULT IN DAMAGE TO BOTH THE SWITCHING DEVICE AND THE COMPARTMENT.**

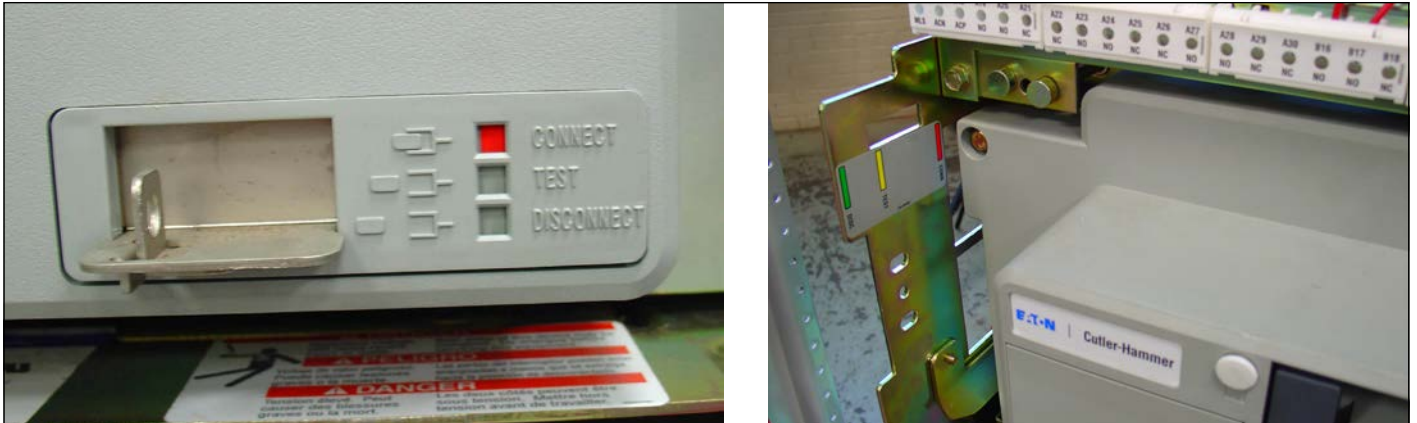

Figure 30. Switching Device in the CONNECT Position.

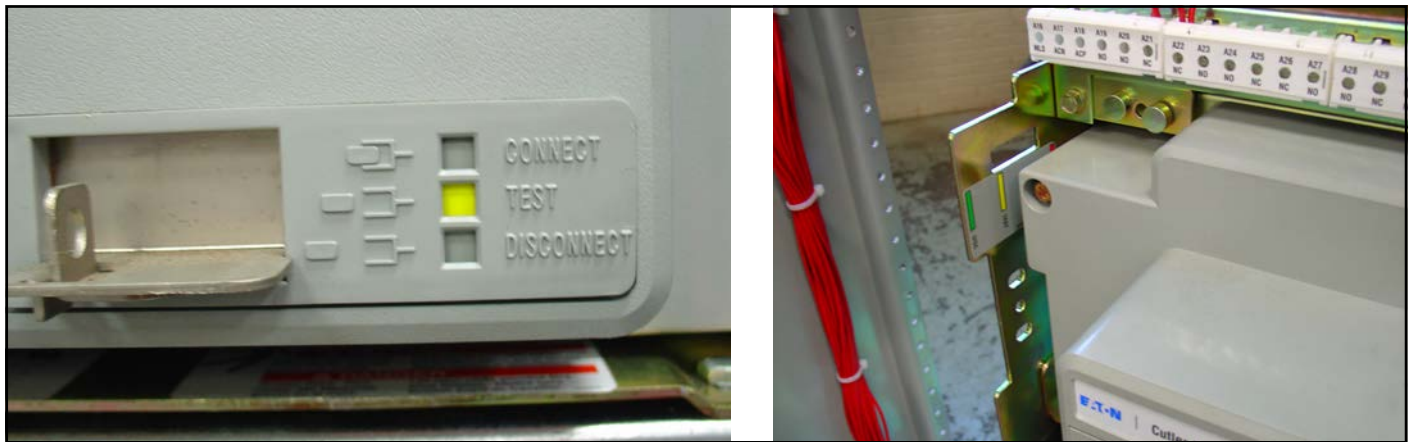

Figure 31. Switching Device in the TEST Position.

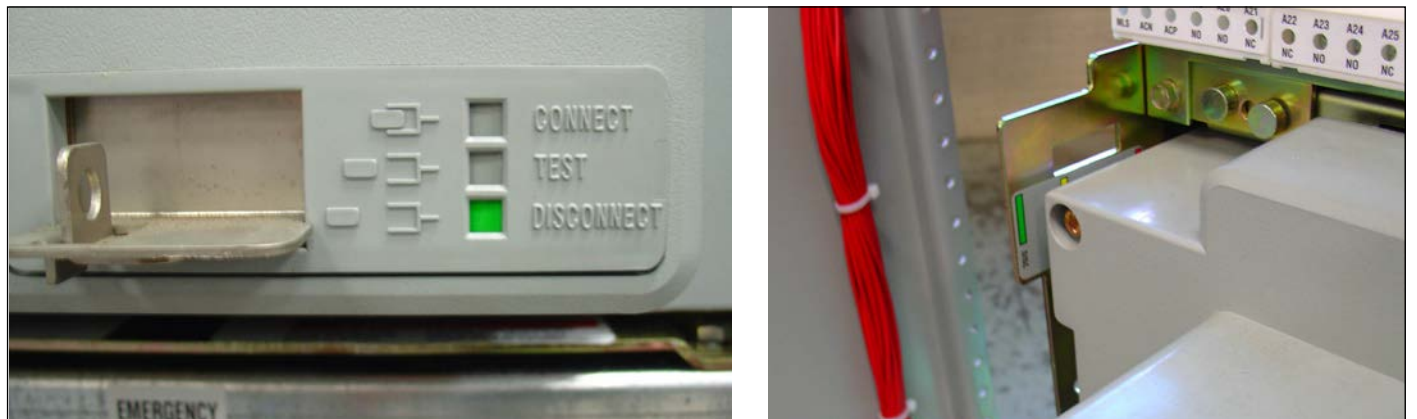

Figure 32. Switching Device in the DISCONNECT Position.

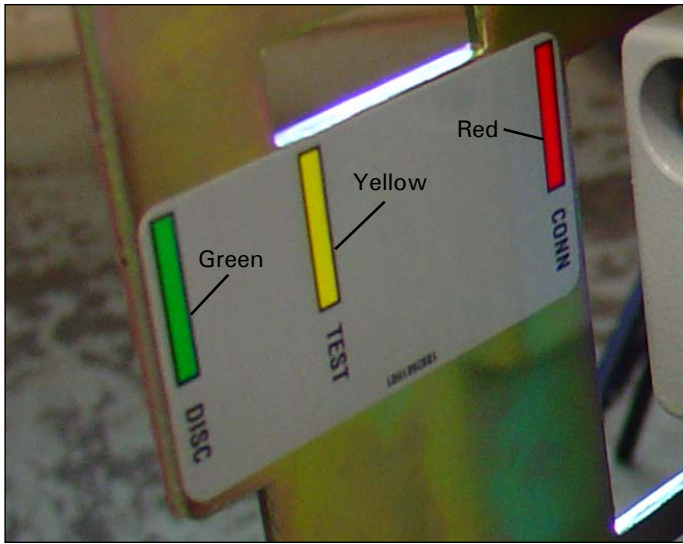

Figure 33. Carriage Label Showing DISCONNECT, TEST, and CONNECT Positions of the Recessed Cover.

6.1.2 Levering the Switching Device

The switching device is now ready to be levered. With the switching device OPEN, the levering device access door can be raised. The levering device is hand operated using a standard 3/8" square drive and ratchet, which is not provided (Figure 34). As long as the access door is raised, the switching device is held in the "trip free" condition. Begin by rotating the levering-in screw to the full counter clockwise (DISCONNECT) position.



Figure 34. Levering and Position Indication.

Close the compartment door and begin levering the switching device into its different positions using a clockwise ratcheting motion. When the switching device is levered fully to the DISCONNECT or CONNECT position, the levering shaft hits a hard stop. Do NOT exceed 25 ft lb (33.9 Nm) of torque or the levering mechanism may be damaged.

NOTICE

**THE SWITCHING DEVICE CAN BE LEVERED WITH THE COMPARTMENT DOOR OPEN OR CLOSED, BUT IT IS ADVISABLE TO CLOSE THE DOOR PRIOR TO LEVERING.**

The position of the switching device within its compartment is indicated by color coded position indicators (See Figure 30 through 33):

- Red = Connect;
- Yellow = Test; and
- Green = Disconnect.

To remove the switching device from its compartment, follow the procedure just described using a counter clockwise ratcheting motion.

NOTICE

**THE SWITCHING DEVICE MECHANISM IS INTERLOCKED SUCH THAT CHARGED CLOSING SPRINGS ARE AUTOMATICALLY DISCHARGED IF THE SWITCHING DEVICE IS LEVERED INTO OR OUT OF THE CELL. DISCHARGE TAKES PLACE BETWEEN THE DISCONNECT AND TEST POSITION.**

6.2. Fixed Switching Device

The Magnum fixed type switching device differs from the drawout version in that it has no levering device, primary disconnects, and secondary disconnects (Figure 35). In addition, a fixed switching device does not have a standard feature to hold the switching device in a "trip free" position



Figure 35. Typical Magnum Fixed Switching Device.

Fixed switching device terminals have holes for making bolted horizontal primary bus connections. Adapters are available for making vertical primary bus connections. Secondary connections can be made through standard terminal blocks or a special connector compatible with the drawout switching device's type secondary connector. Both secondary connection devices are mounted at the top front of the switching device.

The fixed switching device frame has two mounting feet, one on each side, to permit the fixed switching device to be securely mounted. Each mounting foot has two slotted mounting holes which are used to bolt the switching device securely in place. Use either 3/8" or M 10 bolts for this purpose. Refer to the dimensional drawings supplied with the transfer switch for switching device and bus stab dimensions.

### 6.3 Switching Device Operation

Switching devices should be operated manually and/or electrically before they are put into service. This can be done during the installation process or some later date prior to start-up. To check the switching device operation, follow the operational procedures outlined in switching device manual supplied with the transfer switch for both manually operated and electrically operated switching devices.

## Section 7: Operation of the Bypass Isolation Transfer Switch

### 7.1 Operator Panel

The design of this transfer switch allows quick removal of the different switching devices for inspection or maintenance or, if required, quick replacement.

Depending on the optional features selected by the customer the bypass isolation switch will have two operator panels with switches and lights (Figure 36 and 37).

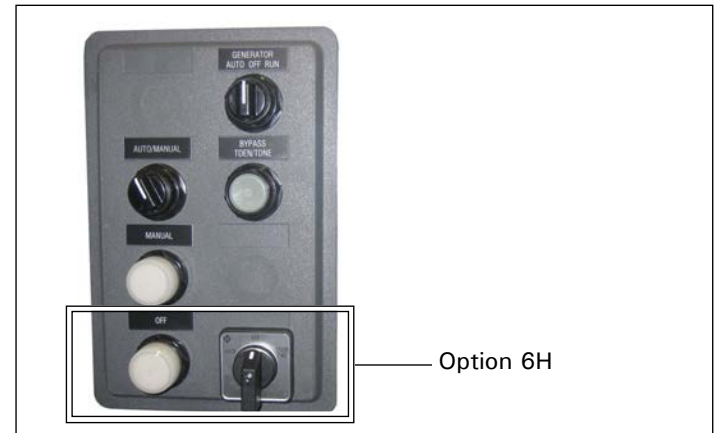

**Figure 36. Typical Bypass Isolation Transfer Switch Device Panel.**

The left door control panel will have following standard features:

1. AMBER LED on the ATC-900 Controller to indicate if the Source 1 power source is available.
2. AMBER LED on the ATC-900 Controller to indicate if the Source 2 power source is available.
3. GREEN LED on the ATC-900 Controller to indicate if the Source 1 position is energized, that is, the Source 1 switching device in the automatic transfer switch is closed.
4. RED LED on the ATC-900 Controller to indicate if the Source 2 position is energized, that is, the Source 2 switching device in the automatic transfer switch is closed.
5. The Engine Test Pushbutton can be pressed twice and released with the ATC-900 controller in the status state to initiate a self test. This test can be initiated and accomplished while in the Run or Program Modes. Pressing the Engine Test Pushbutton again while in the engine run condition aborts the test.

Upon test initiation, a generator start of the non-preferred source is engaged after TDES timeout. If a full test is programmed, a transfer with all programmed timers occurs. The test engine run timer will hold the load for the required timeout and the test is concluded with a re-transfer cycle. For an engine run only test, no transfer will occur and the engine will run for the programmed run time.

6. Three-position selector switch to control the generator:
  - AUTO - The intelligence circuit of the transfer switch will start the generator if the Source 1 power source is not available.
  - OFF - The intelligence circuit of the transfer switch will not be able to start the generator, which eliminates nuisance starts during maintenance.
  - RUN - The generator will run regardless of the availability of the Source 1 power source.



Figure 37. Magnum Bypass Lights.

The right door control panel has following standard features:

1. BLUE light to indicate if the Source 1 switching device is isolated (only if the Source 1 switching device is racked out).
2. BLUE light to indicate if the Source 2 switching device is isolated (only if the Source 2 switching device is racked out).
3. RED light to indicate if the Source 1 bypass switching device is closed.
4. RED light to indicate if the Source 2 bypass switching device is closed.

## 7.2 Automatic Operation

The intelligence/supervisory circuits on Eaton transfer switches constantly monitor the condition of both the Source 1 and Source 2 power sources. These circuits automatically initiate an immediate transfer of power from the Source 1 to the Source 2 power source when the power source fails or the voltage level drops below a preset value. Transfer back to the Source 1 power source is automatic upon return of the Source 1 power source. Monitoring the power source is always performed on the line side of the power source to which the switch is connected. The Source 1 power source is the preferred source and the transfer switch will always seek this source when it is available.

## 7.3 Bypassing the Transfer Switch

For a Bypass type switch, there are instructions on the front of the door and will be changed depending on the options,

### WARNING

**THE CLOSED TRANSITION PRODUCT CONTAINS A SPECIAL CONTACT ARRANGEMENT (OVERLAPPING CONTACTS). MISUSE CAN RESULT IN DEATH, SEVERE PERSONAL INJURY, AND/OR PROPERTY DAMAGE.**

### 7.3.1 Source 1 to Source 1 Bypass

The Source 1 switching device can be bypassed and isolated by the following sequence (Figures 36, 37, 38, and 39):

1. Move the generator selector switch to the OFF position to avoid nuisance starts.
2. Close the Source 1 bypass switch manually. The Source 1 bypass RED light will illuminate.
3. Remove J7 Plug from ATC-900 controller. The switch may contain a Maintenance switch (9B) or a Test switch (6H) and in these cases removal of the J7 power connector is not necessary. Instructions are provided on the door.
4. Open and rack out the Source 1 switching device (see Section 6). The Source 1 isolated BLUE light will illuminate and the Source 1 position energized GREEN LED on the ATC-900 controller will no longer be illuminated.
5. Inspect and/or perform the needed maintenance on the Source 1 switching device.
6. Rack in the Source 1 switching device (see Section 6). The Source 1 switching device will automatically recharge when it is in the CONNECT position.
7. Reconnect J7 plug back onto the ATC-900 controller.
8. ATC-900 controller will automatically sense the availability of the preferred Source 1 and will connect the Source 1 switching device. Source 1 isolated BLUE light will no longer be illuminated and the Source 1 position energized GREEN LED will be illuminated.
9. Open the Source 1 bypass switch. The Source 1 bypass RED light will no longer be illuminated.
10. Move the generator selector switch to the AUTO position
11. The Source 1 switching device is now back in automatic operation.

### 7.3.2 Source 2 to Source 2 Bypass

The Source 2 switching device can be bypassed and isolated by the following sequence (considering Source 2 is the only source available):

1. Move the generator selector switch to the RUN position to avoid losing power to source 2.
2. Close the Source 2 bypass switch manually. The Source 2 bypass RED light will illuminate.
3. Remove J7 Plug from ATC-900 controller. The switch may contain a Maintenance switch (9B) or a Test switch (6H) and in these cases removal of the J7 power connector is not necessary. Instructions are provided on the door.
4. Open and rack out the Source 2 switching device (see Section 6). The Source 2 isolated BLUE light will illuminate and the Source 2 position energized RED LED on the ACT-900 controller will no longer be illuminated.
5. Inspect and/or perform the needed maintenance on the Source 2 switching device.
6. Rack in the Source 2 switching device (see Section 6). The Source 2 switching device will automatically recharge when in the CONNECT position.
7. Reconnect J7 plug back onto the ATC-900 controller.
8. ATC-900 controller will automatically sense the availability of the Source 2 and will connect the Source 2 switching device. Source 2 isolated BLUE light will no longer be illuminated and the Source 2 position energized RED LED will be illuminated.

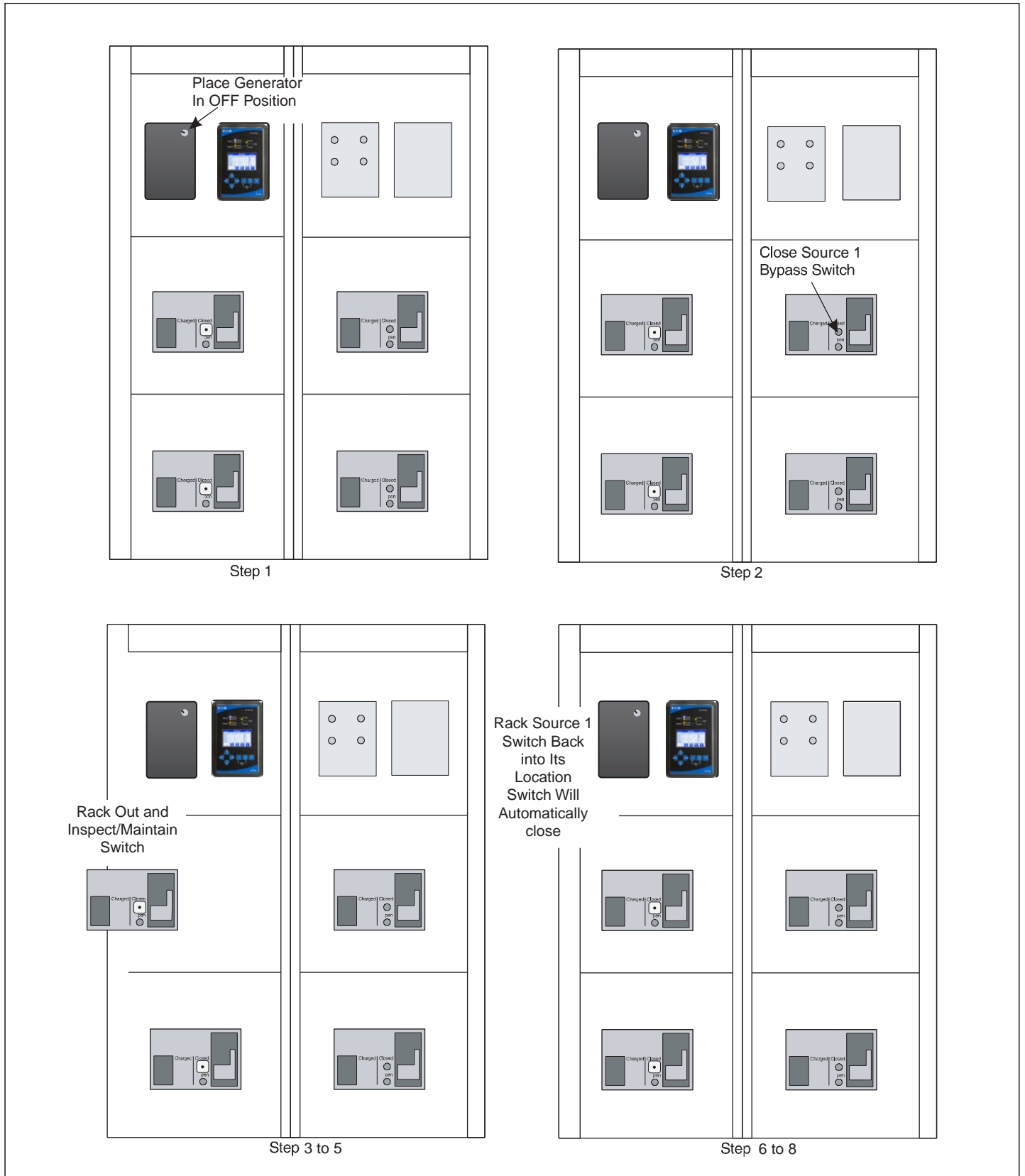

**Figure 38. Transfer from Normal Switching Device to Normal Bypass Switching Device, Steps 1-8.**

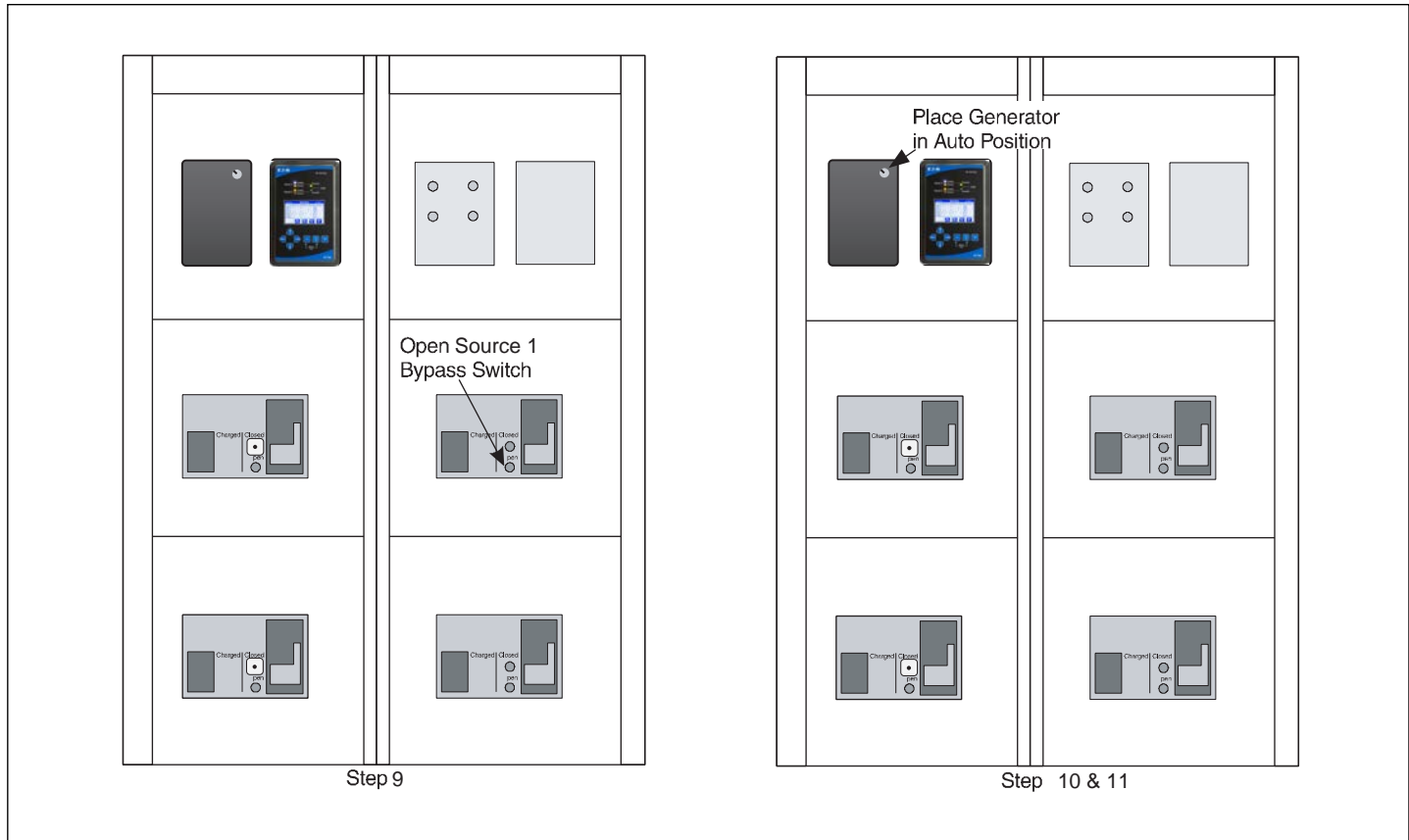

**Figure 39. Transfer from Normal Switching Device to Normal Bypass Switching Device, Steps 9-11.**

9. Open the Source 2 Bypass switch. The source 2 Bypass RED light will no longer be illuminated.
10. Move the generator selector switch to the AUTO position.
11. The Source 2 Switching device is now back in automatic operation.

**7.3.3 Source 1 to Source 2 Bypass (Open Transition Only)**

The Source 1 switching device can be isolated and bypassed to source 2 by the following sequence:

1. Move the generator selector switch to the RUN position because the load needs to be energized from the Source 2 power source.
2. Make sure that the Source 2 power source is available.
3. Remove J7 Plug from ATC-900 controller.
4. Open and rack out the Source 1 switching device manually (see Section 6). The Source 1 isolated BLUE light will illuminate and Source 1 position energized GREEN LED will no longer be illuminated.
5. Close the Source 2 bypass switching device manually. The Source 2 bypass RED light will be illuminated.
6. Inspect and/or perform the needed maintenance on the Source 1 switching device.
7. Rack in the Source 1 switching device (see Section 6). The Source 1 switching device will automatically recharge when it is in the CONNECT position. The Source 1 isolated BLUE light will no longer be illuminated.

**Note:** Source 1 switching device will not be closed with Source 2 bypass switching device closed due to mechanical interlock.

8. Reconnect J7 plug back onto the ATC-900 controller.
9. Open the Source 2 bypass switching device. The Source 2 bypass RED light will no longer be illuminated.
10. The Source 1 switching device should now automatically close and Source 1 position energized GREEN LED will be illuminated.
11. Move the generator selector switch to the AUTO position.
12. The Source 1 switching device is now back in automatic operation.

**7.3.4 Source 2 to Source 1 Bypass (Open Transition Only)**

The Source 2 switching device can be bypassed to source 1 by the following sequence:

**Note:** This operation can be performed by programming Preferred Source = Source 2 inside the ATC-900 controller

1. Ensure that the Source 1 power is available since the load will be energized from the Source 1 power source.
2. Move the generator selector switch to the OFF position to avoid nuisance starting of the generator while work is being performed on the Source 2 switching device.
3. Remove J7 PLUG from ATC-900 controller.
4. Open and rack out the Source 2 switching device manually (see Section 6). The source 2 isolated BLUE light will illuminate and Source 2 position energized RED LED will no longer be illuminated.

5. Close the Source 1 bypass switching device manually. The Source 1 bypass BLUE light will illuminate.
  6. Inspect and/or perform the needed maintenance on the Source 2 switching device.
  7. Rack in the Source 2 switching device (see Section 6). The Source 2 Switching device will automatically recharge when it is in the Connect position. The source 2 isolated BLUE light will no longer be illuminated.
- Note:** Source 2 switching device will not be closed with Source 1 bypass switching device closed due to mechanical interlock.
8. Reconnect J7 plug back onto the ATC-900 controller.
  9. Open the Source 1 bypass switching device. The Source 1 bypass BLUE light will no longer be illuminated.
  10. The Source 2 switching device should now automatically close and Source 2 position energized RED LED will be illuminated.
  11. Move the generator selector switch to the AUTO position.
  12. The Source 2 switching device is now back in automatic operation.
  13. Now re-program Preferred Source = Source 1 inside the ATC controller.
  14. With Source 1 available as a preferred source, Source 2 switching device should now open automatically close and Source 1 switching device should close automatically. Source 2 position energized RED LED will no longer be illuminated and Source 1 position energized GREEN LED will be illuminated.

## 7.4 Manual Operation When in Bypass Mode

### 7.4.1 Source 1 Bypass to Source 2 Bypass

When the transfer switch is set to Source 1 bypass, it can be transferred to Source 2 bypass by the following sequence:

1. Move the generator selector switch to the RUN position.
2. Open the Source 1 bypass switching device. The Source 1 bypass RED light will no longer be illuminated.
3. Close the Source 2 bypass switching device manually and the Source 2 bypass RED light will illuminate.

### 7.4.2 Source 2 Bypass to Source 1 Bypass

When the transfer switch is set to Source 2 bypass, it can be transferred to the Source 1 bypass switching device by the following sequence:

1. Open the Source 2 bypass switching device and the Source 2 bypass RED light will no longer be illuminated.
2. Close the Source 1 bypass switching device manually and the Source 1 bypass RED light will illuminate.
3. Move the generator selector switch to the OFF or AUTO position.

## Section 8: Testing and Problem Solving

### 8.1 Testing

After transfer switch equipment is initially installed or during planned outages, the installation should be tested to ensure that all equipment operates properly. This attention to detail will help to avoid unexpected malfunctions. Mechanical and/or electrical tests should be performed.

The frequency of subsequent testing should be based on recommendations of the generator set manufacturer. Use the test push-button to check the electrical operation of the switch. **IF A TEST SWITCH IS PROVIDED, ALWAYS RETURN THE SWITCH TO THE AUTO POSITION AFTER THE TEST IS COMPLETE.**

#### WARNING

**HIGH VOLTAGES ASSOCIATED WITH OPERATIONAL TRANSFER SWITCH EQUIPMENT PRESENT A SHOCK HAZARD THAT CAN CAUSE SEVERE PERSONAL INJURY OR DEATH. USE EXTREME CAUTION TO AVOID TOUCHING ELECTRICAL CONNECTIONS WHENEVER INSPECTING OR TESTING THE EQUIPMENT.**

**IN ADDITION, IMPROPER OPERATION OF THE GENERATOR SET PRESENTS A HAZARD THAT CAN CAUSE SEVERE PERSONAL INJURY OR DEATH. OBSERVE ALL SAFETY PRECAUTIONS IN YOUR GENERATOR SET OPERATIONS AND INSTALLATION MANUALS**

#### WARNING

**FOR MECHANICAL OPERATIONS, REFER TO SECTION 5. IN THIS INSTRUCTION BOOK. REFER TO THE APPLICABLE LOGIC INSTRUCTION BOOK FOR ELECTRICAL TESTING**

### 8.2 Problem Solving

#### WARNING

**HAZARDOUS VOLTAGES IN AND AROUND TRANSFER SWITCH EQUIPMENT DURING THE PROBLEM SOLVING PROCESS CAN CAUSE PERSONAL INJURY AND/OR DEATH. AVOID CONTACT WITH ANY VOLTAGE SOURCE WHILE PROBLEM SOLVING.**

#### WARNING

**ONLY PROPERLY TRAINED PERSONNEL FAMILIAR WITH THE TRANSFER SWITCH EQUIPMENT AND ITS ASSOCIATED EQUIPMENT SHOULD BE PERMITTED TO PERFORM THE PROBLEM SOLVING FUNCTION. IF AN INDIVIDUAL DOES NOT FEEL QUALIFIED TO PERFORM THE PROBLEM SOLVING FUNCTION, THE INDIVIDUAL SHOULD NOT ATTEMPT TO PERFORM ANY OF THESE PROCEDURES.**

A basic problem solving effort is the first step to take prior to calling for assistance. Frequently, the effort will successfully address most problems encountered. Most problem solving procedures are outlined in the instruction manual unique to the type of logic being used. In addition, several problem solving procedures are presented here which are specific to the type of switches or switching devices used in this equipment.

If a problem persists after having completed the problem solving procedure, contact an Eaton representative for further assistance. When calling for assistance, the following is the MINIMUM information required to properly address the need:

1. General Order Number (GO #) of the transfer switch, plus related Item Number;
2. Catalog and/or Style Number of the transfer switch;
3. Actual location of transfer switch (type of facility, address, etc.);
4. Company name;
5. Name and position of individual representing company;
6. Basic description of situation as it exists; and
7. Any results of problem solving steps taken and/or readings taken.

### **WARNING**

**THIS CLOSED TRANSITION PRODUCT CONTAINS A SPECIAL CONTACT ARRANGEMENT (OVERLAPPING CONTACTS). MISUSE CAN RESULT IN DEATH, SEVERE PERSONAL INJURY, AND/OR PROPERTY DAMAGE.**

#### 8.2.1 Transfer Switch Appears Inoperative

- Step 1:** Verify that all plugs and sockets are properly interconnected.
- Step 2:** Verify that the correct system voltage appears at Source 1 switch. Measure the voltage at the breaker lugs.
- Step 3:** Verify that the voltage selection plug is in the proper position to match the system voltage.
- Step 4:** Look for any obviously burned components. Determine the cause and rectify, if possible. Replace any defective components after the cause is determined.
- Step 5:** For **closed transition**, refer to Figure 25 for manual operating instructions. Verify whether or not the system voltage now appears on the load terminals.  
 If YES: Check the logic for problems in the respective logic instruction book.  
 If NO: Check all power connections and the switching mechanism.
- Step 5:** For **open transition**, press the Push-To-Close button on the Source 1 switching device. Verify whether or not the system voltage now appears on the load terminals.  
 If YES: Check the logic for problems in the respective logic instruction book.  
 If NO: Check all power connections and the switching mechanism.

#### 8.2.2 Transfer Switch Will Not Automatically Transfer to Source 1

- Step 1:** Check for the proper line voltage on N1, N2, and N3.
- Step 2:** Is the Source 1 switching device charged?  
 If YES: Continue with the other procedures.  
 If NO: Go through section 8.2.4 first before continuing.

#### Step 3: Is the Source 2 switch OPEN?

- If YES: Proceed to Step 5.  
 If NO: Proceed to Step 4.

#### Step 4: Measure the voltage between terminals S2B10 and S2B11 on the Source 2 switching device (shunt trip). Does the voltage measure 120 Vac ± 10 volts? Record the reading.

- If YES: Check the shunt trip in the Source 2 switch.  
 If NO: Check the wiring to S2B10 and S2B11.

#### Step 5: Measure the voltage between terminals S1B12 and S1B13 on the Source 1 switching device (spring release coil). Does the voltage measure 120 Vac ± 10 volts? Record the reading.

- If YES: Check the spring release coil in Source 1 switching device.  
 If NO: Check the wiring to S1B12 and S1B13.

#### 8.2.3 Transfer Switch Will Not Automatically Transfer to Source 2

- Step 1:** Check for the proper line voltage on E1, E2, and E3.
- Step 2:** Is the Source 2 switching device charged?  
 If YES: Continue with the other procedures.  
 If NO: Go through Section 8.2.4 first before continuing.
- Step 3:** Is the Source 1 switching device OPEN?  
 If YES: Proceed to Step 5.  
 If NO: Proceed to Step 4.
- Step 4:** Measure the voltage between terminals S1B10 and S1B11 on the Source 1 switching device (shunt trip). Does the voltage measure 120 Vac ± 10 volts? Record the reading.  
 If YES: Check the shunt trip in the Source 1 switch.  
 If NO: Check the wiring to S1B10 and S1B11.
- Step 5:** Measure the voltage between terminals S2B12 and S2B13 on the Source 2 switching device (spring release coil). Does the voltage measure 120 Vac ± 10 volts? Record the reading.  
 If YES: Check the spring release coil in Source 2 switch.  
 If NO: Check the wiring to S2B12 and S2B13.

#### 8.2.4 Transfer Switch Will Not Automatically Recharge Switches

- Step 1:** Measure the voltage between terminals B15 and B14 on the switching device that does not automatically recharge. Does the voltage read 120 Vac ± 10 volts? Record the reading.  
 If YES: Check the electrical operator inside the switching device.  
 If NO: Verify the wiring to B15 and B14.

**Step 2:** If problem persists, contact Eaton.

**Eaton Care for assistance**  
**877-386-2273 option 2, option 4, and then option 3**

**Section 9: Maintenance**

**9.1 Introduction**

 **WARNING**

**HIGH VOLTAGES ARE PRESENT IN AND AROUND TRANSFER SWITCH EQUIPMENT. BEFORE INSPECTING OR MAINTAINING THIS EQUIPMENT, DISCONNECT THE LINE POWER FROM THE EQUIPMENT BEING SERVICED BY OPENING AND LOCKING OUT, IF POSSIBLE, THE NEXT HIGHEST DISCONNECT DEVICE. FAILURE TO FOLLOW THIS PROCEDURE COULD CAUSE PERSONAL INJURY AND/OR DEATH.**

 **WARNING**

**THE CLOSED TRANSITION PRODUCT CONTAINS A SPECIAL CONTACT ARRANGEMENT (OVERLAPPING CONTACTS). MISUSE CAN RESULT IN DEATH, SEVERE PERSONAL INJURY, AND/OR PROPERTY DAMAGE.**

In general, transfer switch equipment is designed to be relatively maintenance free under normal usage. However, because of the variability of application conditions and the importance placed on dependable operation by this type of equipment, inspection and maintenance checks should be made on a regularly scheduled basis. Since equipment maintenance will consist mainly of keeping the equipment clean, the frequency of maintenance will depend, to a large extent, on the cleanliness of the surroundings. If a significant amount of dust or foreign matter is present, a more frequent maintenance schedule should be followed.

It is suggested that visual inspections of the equipment be made on a regular basis, not just during regularly scheduled periods. Always be alert for an accumulation of dirt in and around the structure, loose parts and/or hardware, cracks and/or discoloration to insulation, and damaged or discolored components.

**9.2 Maintenance Procedures**

A suggested maintenance procedure to follow is outlined in Table 6.

**Table 6. Periodic Maintenance Procedures.**

STEP	ACTION
a. Make the transfer switch equipment safe for inspection and/or maintenance.	Disconnect the line power from the equipment being serviced by opening next highest disconnect device. Make certain that any accessory control power is switched off and the logic plugs are disconnected
b. Inspect the structure area for any safety hazards or potential maintenance problems.	Inspect the area, especially where switching devices are installed, for any safety hazards, including personnel safety and fire hazards. Exposure to certain chemical vapors can cause deterioration of electrical connections.  Inspect for accumulated dirt, loose hardware, or physical damage.  Examine the primary insulation for evidence of cracking or overheating. Overheating will show as discoloration, melting or blistering of conductor insulation, or as pitting or melting of conductor surfaces due to arcing.  Inspect the secondary control connections for damage and the control wiring for insulation integrity
c. Inspect the switching devices for dust, dirt, soot, grease, moisture, or corrosion.	Remove the dust, dirt, soot, grease, moisture, and corrosion contamination from the surface of the switching device using a dry, soft lint-free cloth, dry, soft bristle brush, and vacuum cleaner. Do not blow debris into the switching device or nearby breaker structure. If contamination is found, look for the source and fix the problem.
d. Check for material integrity, uneven wear, discoloration, or loose hardware.	Severe material cracking will require replacement and loose hardware will need to be tightened.
e. Check all terminals and connectors for looseness or signs of overheating.	Overheating will show as discoloration, melting, or blistering of conductor insulation.  Connections that do not have signs of looseness or overheating should not be disturbed.
f. Contact Inspection Procedure	Loosen the arc chute retaining screws on the top rear of the breaker, then slide the molded cover toward the back of the breaker. The arc chute can then be lifted out of the molded case and the contacts can be inspected. Contact Eaton Care (1-877-ETN-CARE, Option-2, Option-4, Option-3) if the contacts have excessive wear. Reinstall the arc chute, slide the cover forward and tighten the retaining screw.
g. Exercise the switching devices if they are not often exercised while in operation. This will permit a wiping action by the contacts.	If a switching device is used for frequent switching during normal operation, this step can be disregarded.
h. Inspect NEMA 3R filters for blockage or contamination.	For NEMA 3R enclosed transfer switches with venting, check that the air filters are clean and uncompromised. Replace the filters as necessary.
i. Return the transfer switch equipment to service.	Make certain that all barriers are in place and the doors are closed. Reapply the Source 1 and Source 2 power.

### 9.3 Cover Removal and Replacement

Many of the maintenance procedures outlined in Table 6 require the removal and replacement of side and rear covers. For all NEMA 1 and NEMA 3R enclosed transfer switches, see Section 9.3.1 for cover removal and replacement instructions.

#### 9.3.1 Cover Removal and Replacement

A 3/8" wrench or socket and ratchet is required to perform this procedure.

##### **Cover Removal**

**Step 1:** Locate the bolts used to secure the cover to the frame and remove them with the 3/8" wrench. Remove the top screws last while holding the cover in place (Figure 40).

**Step 2:** Allow the top of the cover to slowly tilt away from the enclosure frame (Figure 41).

**Step 3:** Move your hands around to the sides and lift the cover free (Figure 42).



Figure 41. Tilting the Cover Away from the Frame.



Figure 42. Lifting the Cover Free.



Figure 40. Removing the Bolts.

**Section 10: Renewal Parts Guide**

**10.1 General**

Refer to Figure 43 through 45 for assistance with selecting and ordering selected ATS renewal parts.

The replacement controller needs to match the originally supplied features. The easiest way to supply this list is to provide the **original order number** on the original shipment. The ATS product line has a data base that is maintained with the original feature list. The general order number or GO # is on the nameplate of the ATS located on the inside of the door. In addition it is very helpful to also supply the **15 digit catalog number** of the ATS. This number is also available on the nameplate of the ATS.

SWITCH TYPE	CONTROLLER	REPLACEMENT STYLE	
<b>Magnum Based Design</b>			
Magnum Open Transition	ATC-900	ATC-900BTONI	A
Magnum Closed Transition Only	ATC-900	ATC-900BTONCF	D
Magnum Closed Transition with Open, In-phase, LVD, TDN	ATC-900	ATC-900BTONIC	B

Harness's may change depending on certain options ordered. The best way to order a harness is to call tech support or sales with the GO number

There is a new top shelf for the switch that moves some components that do not need nearly any attention. This added shelf removes some large components from the bottom panel (Figure 43) and places them on the top shelf as shown in Figure 44. The top shelf shown in the figure has a PXG200, power supply, and a covered transformer for the larger heater. Other components may include PTs, metering housings, etc.



**Figure 44. Top Component Shelf**

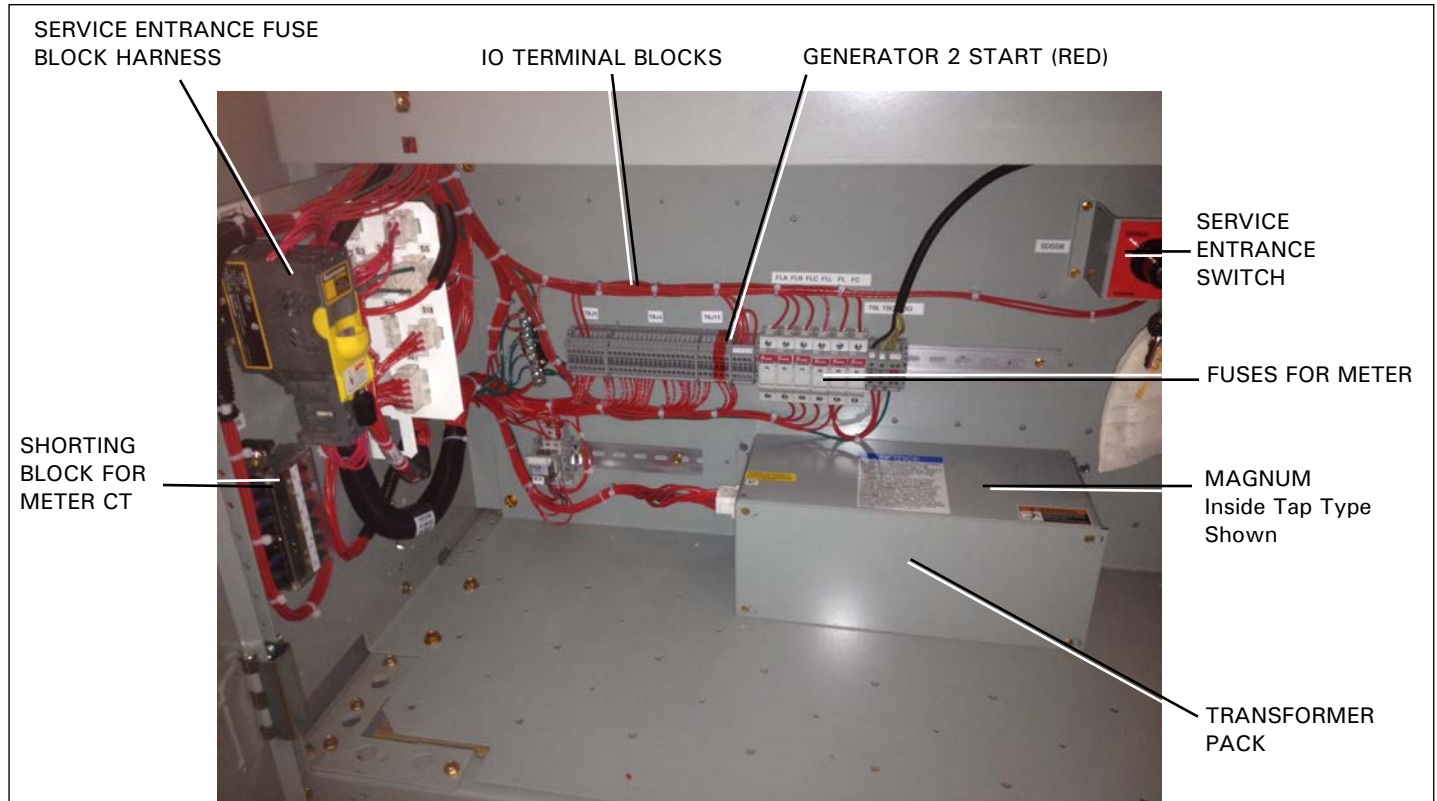

**Figure 43. Bottom Panel for User Interface**

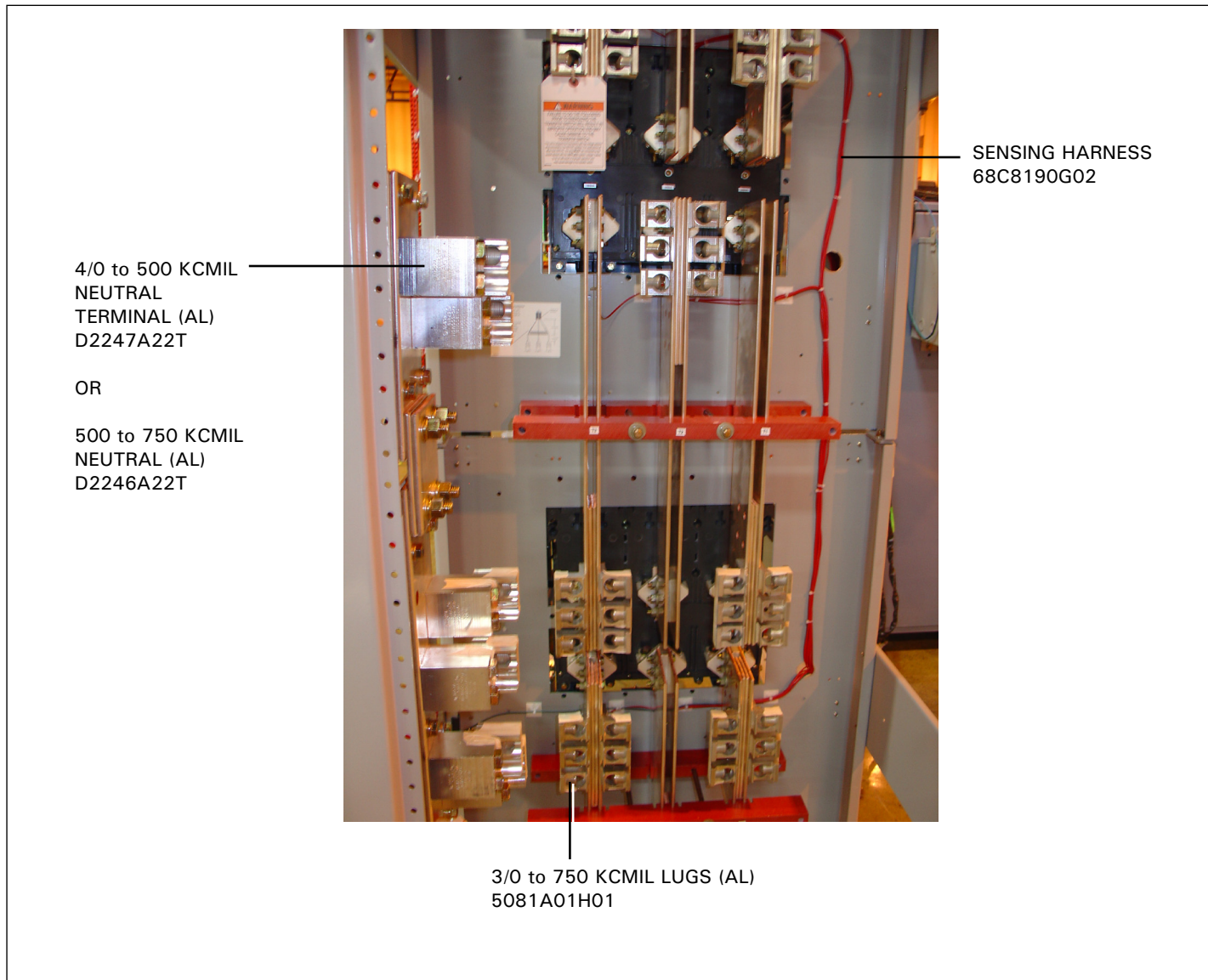

Figure 45. Rear of Switch

**Notes:**

**Notes:**

**Notes:**

This instruction booklet is published solely for information purposes and should not be considered all-inclusive. If further information is required, you should consult an authorized Eaton sales representative.

The sale of the product shown in this literature is subject to the terms and conditions outlined in appropriate Eaton selling policies or other contractual agreement between the parties. This literature is not intended to and does not enlarge or add to any such contract. The sole source governing the rights and remedies of any purchaser of this equipment is the contract between the purchaser and Eaton.

NO WARRANTIES, EXPRESSED OR IMPLIED, INCLUDING WARRANTIES OF FITNESS FOR A PARTICULAR PURPOSE OR MERCHANTABILITY, OR WARRANTIES ARISING FROM COURSE OF DEALING OR USAGE OF TRADE, ARE MADE REGARDING THE INFORMATION, RECOMMENDATIONS, AND DESCRIPTIONS CONTAINED HEREIN. In no event will Eaton be responsible to the purchaser or user in contract, in tort (including negligence), strict liability or otherwise for any special, indirect, incidental or consequential damage or loss whatsoever, including but not limited to damage or loss of use of equipment, plant or power system, cost of capital, loss of power, additional expenses in the use of existing power facilities, or claims against the purchaser or user by its customers resulting from the use of the information, recommendations and description contained herein.

CSA is a registered trademark of the Canadian Standards Association. National Electrical Code and NEC are registered trademarks of the National Fire Protection Association, Quincy, Mass. NEMA is the registered trademark and service mark of the National Electrical Manufacturers Association. Uniform Building Code (UBC) is a trademark of the International Conference of Building Officials (ICBO). UL is a federally registered trademark of Underwriters Laboratories Inc.

Eaton  
Electrical Sector  
1000 Eaton Boulevard  
Cleveland, Ohio 44122  
United States  
877-ETN CARE (877-386-2273)  
Eaton.com