



New Information
Reprint of B.15A.04A.S.E
pages 1-12, dated November 1999.

Automatic and Non-Automatic Transfer Switches Free Standing 600-4000 Amperes

Table of Contents	Page
Introduction	2
Design Highlights	2
Typical Applications	3
Basic Switch Components	3
Mini-SPB Switches	4
SPB Fixed Mount Switches	4
SPB Drawout Switches	4
Transfer Switch Withstand Ratings	4
Power and Transformer Panels	5
Logic	6
Switch and Feature Selection	7-9
Dimensions and Weights	10-12



Introduction

Cutler-Hammer SPB Transfer Switches are designed for a variety of standby power applications for critical loads. They monitor both normal and standby power sources. In the event of a primary power source interruption, these switches will automatically transfer the load circuits to the standby power source. Once primary power has been restored, the process is automatically reversed.

The SPB family of transfer switches cover applications ranging from 600 to 4000 amperes through 600 Vac, in Automatic, Manual or Non-Automatic configurations, open or closed transition, standard or service entrance. They are designed for applications where total system coordination must be accomplished while achieving a high level of Withstand, Interrupting and Closing performance.

Drawout construction is available for applications, such as critical life support systems, where preventive maintenance, inspection and testing must be accomplished while maintaining continuity of power to the load.

Cutler-Hammer SPB Transfer Switches meet or exceed all industry standards for endurance, reliability and performance. They are listed under Underwriters Laboratories UL 1008 Standard for Transfer Switch Equipment. With certain options, they also comply with emergency and standby system requirements as defined in NFPA 99 for health care facilities.

SPB Transfer Switch Family

- Mini-SPB fixed mount 600-1200 amperes
- SPB fixed mount 800-4000 amperes
- SPB drawout 800-4000 amperes

The Cutler-Hammer family of SPB Transfer Switches offers the utmost in flexibility, reliability and value. These switches must exceed many national and international standards. They are designed and built in accordance with the following:

UL 1008	Standard for Safety for Automatic Transfer Switches
UL 489	Standard for Circuit Breakers and Molded Case Switches
NEC Articles 517, 700, 701, 702	Code Sections Applicable Switch Equipment
NFPA 110	Emergency and Standby Power Systems
NFPA 99	Health Care Facilities
EGSA 100S	Standard for Transfer Switches
NEMA ICS10	Standard for Transfer Switch Equipment
UBC	Uniform Building Code for Seismic Zone 4
ISO 9000	International Organization for Standardization

Design Highlights

- UL 1008 listed
- Free standing
- SPB insulated case switches
- High withstand ratings
- Full 60-cycle short time withstand capability
- Safe manual transfer under load
- IQ Transfer Logic (automatic)
- Multi-tap voltage selection plug
- Integral service entrance capability
- Integral overcurrent protection capability
- Drawout capability
- Durable powder-coated steel enclosures
- UBC Zone 4 seismic qualified
- American Bureau of Shipping qualified
- ISO 9001 designed
- ISO 9002 manufactured
- ISO 14001 manufacturing facility

Typical Applications

Utility – Generator

Transfer switches are traditionally applied between a utility and a generator set for emergency and stand-by power systems.

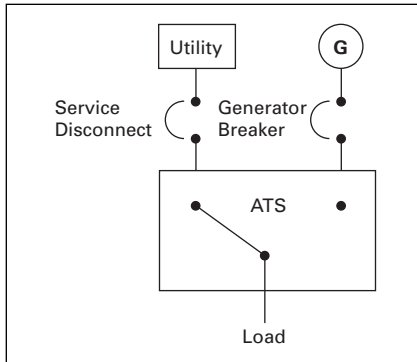

Standard Application Utility – Generator

Generator – Generator

Transfer switches are sometimes applied between two generator sets for prime power use, often in remote installations. In such applications, source power is periodically alternated between the generator sets to equally share run time between the two.

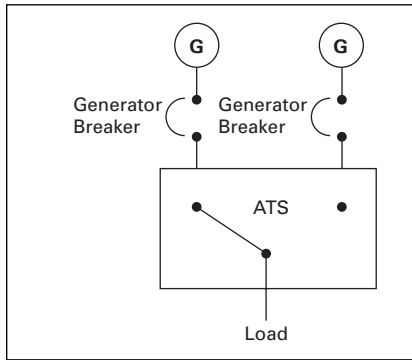

Standard Application Generator – Generator

Service Entrance Equipment

Often, it is desirable to apply the transfer switch as a service equipment device thereby eliminating the need for separate service disconnects and overcurrent protective devices. This switch is particularly adaptable to wastewater and water treatment plants, pumping stations, industrial plants, telecommunications facilities and other installations where all the loads are critical in nature and need to be backed up by an alternate power source.

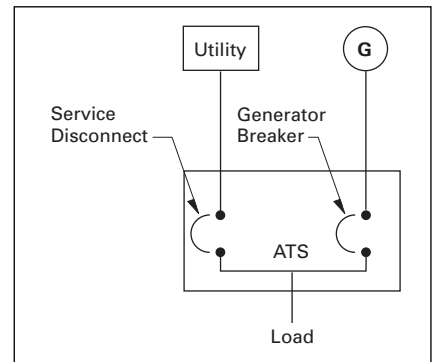

Service Entrance Application

Basic Components of SPB Automatic Transfer Switches

Indicating Lights

Logic [IQ Transfer (ATC-600) Shown]

- Monitors Source Condition
- Initiates Power Transfers

Transformer Panel

- Steps line power down to 120 Vac for logic and electrical operator control power
- Multi-Tap Voltage Selector for application on a variety of system voltages
- Engine Start Contacts

Dead Front Cover

Power Panel

Manual Charging Handle

Electrical Operator Push Button

Power Panel

- Performs power transfer between Normal and Emergency Sources utilizing SPB Insulated Case Switches or Circuit Breakers

Mini-SPB and SPB Fixed Mount Transfer Switches



1200 Ampere, 3-pole NEMA 1 Enclosed



3000 Amperes, 4-pole, NEMA 1 Enclosed

SPB Drawout Transfer Switch



2000 Amperes, 3-pole NEMA 1 Enclosed Drawout

Mini-SPB Fixed Mount

- 600-1200 amperes
- 2-, 3-, 4-pole
- 120-600 Vac
- 65,000 amperes withstand/closing/interrupting at 480 Vac
- Fixed mount construction
- Available in Type 1, 3R, 4, 4X and 12 enclosures
- Front cable access

Catalog Number
ATVISPA31200XSU

SPB Fixed Mount

- 800-4000 amperes
- 2-, 3-, 4-pole (except 4000 amperes: 2- and 3-pole only)
- 120-600 Vac
- 100,000 amperes withstand/closing/interrupting at 480 Vac
- Fixed mount construction
- Available in Type 1 and 3R enclosures
- Rear, side and top cable access

Catalog Number
ATVISPA43000XSU

SPB Drawout

- 800-4000 amperes
- 2-, 3-, 4-pole (except 4000 amperes: 2- and 3-pole only)
- 120-600 Vac
- 100,000 amperes withstand/closing/interrupting at 480 Vac
- Drawout construction with switch position indicator
- Completely interchangeable power switching devices
- Available in Type 1 and 3R enclosures
- Rear, sides and top cable access

The Cutler-Hammer Drawout SPB Switch should be considered for any systems requiring either greater redundancy, easier maintainability or where true selective coordination is desired.

The Cutler-Hammer Drawout SPB Switch provides the capability to isolate either of the two power sources -Normal or Emergency- and its associated logic, while maintaining power to the load.

Each switching section is independent and can be replaced either with a spare switch, or for less critical replacement needs, a replacement unit is available from the factory within 24 hours.

Catalog Number
ATVISPG32000XSU

Transfer Switch Withstand Ratings

Systems Coordination Information — Withstand, Closing and Interrupting Ratings

Standard UL1008 3-Cycle ATS Ampere Rating	Ratings when used with Upstream Breaker (kA)			Ratings when used with Upstream Fuse (kA)		60-Cycle, Extended Rating Ratings used for Coordination with Upstream Breakers with Short Time Ratings			
	Volts			Maximum Fuse Rating	Fuse Type	Volts			
	240	480	600			600	240	480	600

Mini-SPB

600	85	65	65	800	L	200	35	35	35
800	85	65	65	1000	L	200	51	51	51
1000	85	65	65	1600	L	200	51	51	51
1200	85	65	65	1600	L	200	51	51	51

SPB Fixed and Drawout

800	100	100	85	2000	L	200	51	51	51
1000	100	100	85	2000	L	200	51	51	51
1200	100	100	85	2000	L	200	51	51	51
1600	100	100	85	3000	L	200	51	51	51
2000	100	100	85	3000	L	200	51	51	51
2500	100	100	85	4000	L	200	51	51	51
3000	100	100	85	4000	L	200	51	51	51
4000	100	100	85	-	-	-	85	85	85

Power and Transformer Panels

Unmatched Performance and Versatility

The Cutler-Hammer family of SPB transfer switches offers unmatched performance, versatility and value for standby power applications. At the heart of these designs is the SPB insulated case switch with the following features:

Superior Main Contact Structure

All Cutler-Hammer SPB Transfer Switches meet or exceed the standards set forth in UL 1008 and UL 489 with high withstand, totally enclosed SPB switches. No other transfer switch manufacturer has met the rigid testing requirements of this combination of standards. Completely enclosed contacts add a measure of safety and reliability. It also ensures the integrity of the contact assemblies and minimizes the need for periodic maintenance of the contacts, reducing downtime and maintenance time.

Fast, Powerful and Safe Switching Mechanism

The mechanism utilizes a high speed five-cycle stored energy switching mechanism. This mechanism can be operated manually under a FULL LOAD.

Ease of Coordination and Application — Short Time Withstand

The use of electronic trips has allowed performance curve shaping to facilitate proper system coordination. The most significant is the "short time" rated trip unit.

These trip settings may be set for what are considered extremely high currents for much longer durations than the three-cycle withstand test required under UL1008. To facilitate improved coordination, Cutler-Hammer's SPB transfer switches have been tested and are provided with 60-cycle, extended withstand ratings.

SPB Switch Features



SPB Insulated Case Switch

- UL 489 and UL1008 listed
- 65-100 kA standard withstand ratings
- 60-cycle, extended withstand ratings
- Five-cycle closing speed
- Electrically operated
- True 4-pole switched neutral availability
- Totally enclosed contact assembly
- 3A/3B auxiliary contacts for customer connection (each SPB switch)

Optional Integral Overcurrent Protection Capability

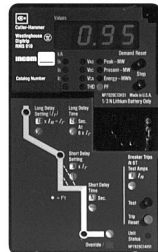

Optional Digitrip SPB Trip Unit

For service entrance and other applications, Digitrip solid state trip units can be integrated into the power switching section. This eliminates the need for separate upstream protective devices, saving cost and space. Available with various combinations of Long, Short Time, Instantaneous, Ground Fault Protection and Communications.

Interlocking for Open Transition Applications

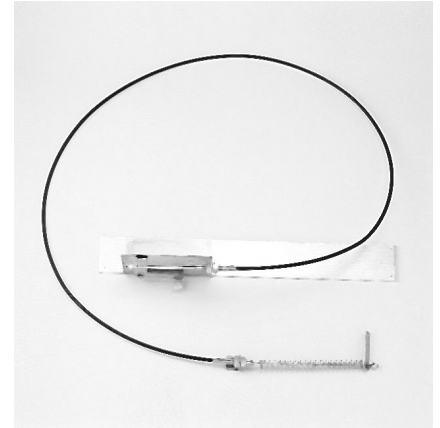

Mechanical Cable Interlock

The open transition type SPB Transfer Switches feature both mechanical (cable) and electrical interlocking to prevent paralleling of sources.

Multi-Tap Voltage Selector

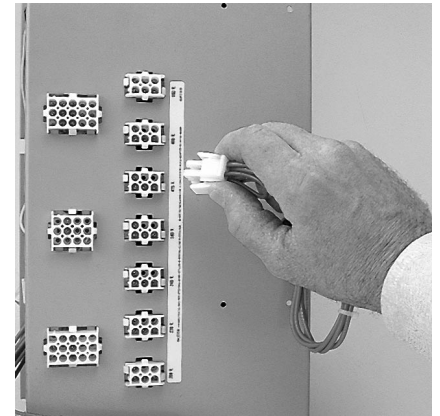

Multi-Tap Voltage Selector

Allows transfer switch to be readily applied on most system voltages worldwide by proper insertion of selector plug. Available system voltages include 208, 220, 240, 380, 415, 480 or 600 Vac, 50 or 60 Hz.

Logic

Application Versatility

Whether the application calls for open or closed transition, manual or automatic operation, Cutler-Hammer has the right logic controller for the task. IQ Transfer controllers have set a new standard for transfer switch technology featuring:

- Microprocessor-based logic
- Digital display
- Field set point programmability
- Transfer history
- PowerNet Communications capability
- Voltmeter and frequency meter
- True rms voltage sensing
- Mimic BUS/LED display
- Load voltage decay delayed transition capability
- In-phase monitor capability
- Field upgrade capability

Automatic Transfer Open Transition



IQ Transfer (ATC-600)

Open transition type SPB transfer switches utilize the Cutler-Hammer programmable IQ Transfer microprocessor-based logic controller.

Available with:

- Time delayed neutral
- Delayed transition-load voltage decay
- In-phase motor

Automatic Transfer Closed Transition



Closed Transition (ATC-800) IQ Transfer

Closed transition applications feature the Closed Transition IQ Transfer logic controller.

Available with two operating sequence choices:

- Closed/alarm
- Closed/in-phase/load voltage decay

Non-Automatic

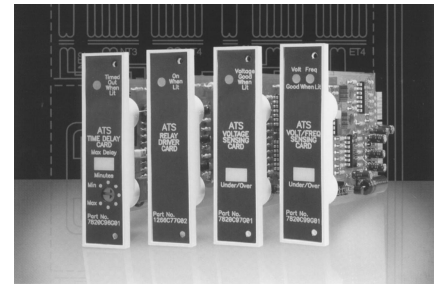

Solid State

Electrically operated transfers are accomplished with the Cutler-Hammer Solid State logic package.

Ease of Maintenance

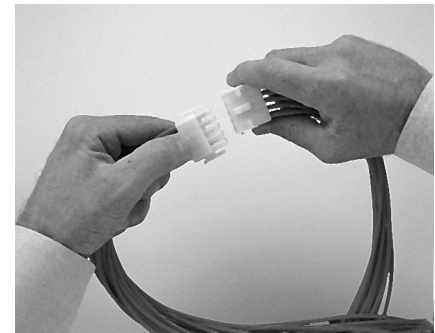

Logic Disconnect Plugs

Keyed quick-disconnect plugs are provided for easy and complete isolation of the control circuitry.

Maintenance can be performed on the logic independent from the power sections and still allow the user to manually transfer power under full load conditions.

Switch and Feature Selection

Cutler-Hammer Transfer Switch Equipment offers flexibility and versatility to the system designer and user. All switches include the basic features necessary for normal operation as standard (see pages 6-7). Cutler-Hammer also offers an extensive array of optional features/accessories that allows the user to customize a new transfer switch to match the application. Select the appropriate catalog number for the application from the table below. Then choose from the following pages any optional features/accessories needed to complete the project requirements.

Catalog Number System

Catalog Number: ATVISP30800XRU with Optional Features 16B, 37B, 32B, 23J, 42

The below example would specify the following:

- Automatic Transfer Switch
- 480 volts
- 3-phase
- 4-wire
- 3-pole
- 800 amperes
- IQ Transfer Logic (ATC-600)
- NEMA 3R enclosure

- UL listed
- Integral overcurrent protection both sources
- Service entrance rated
- Delayed transition-load voltage decay
- Plant exerciser
- Seismic Zone 4 certified
- Feature Group 9 included

Catalog Number Selection Guide

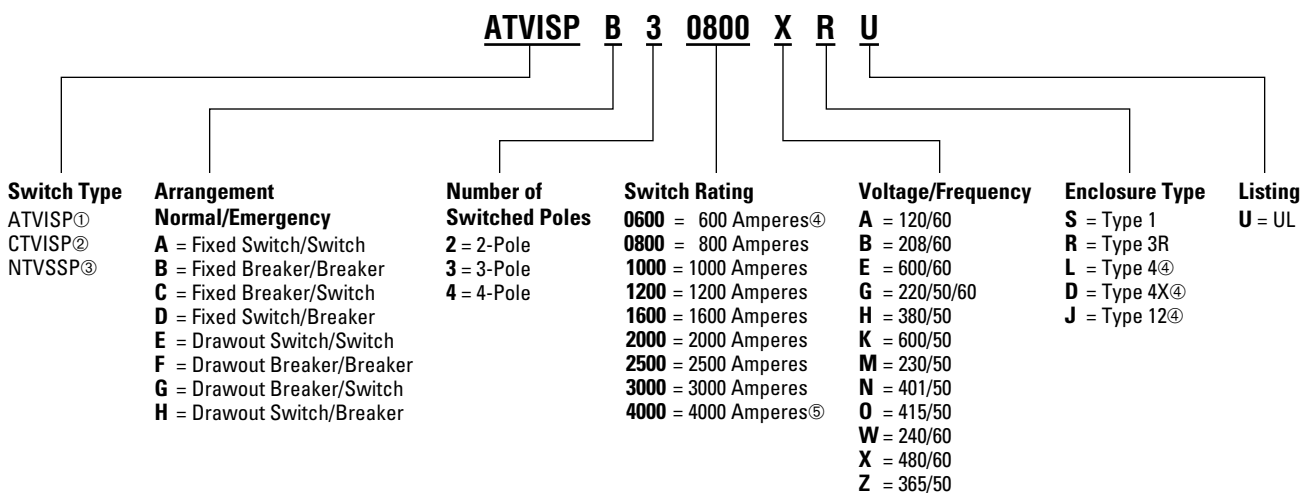

① ATVISP: Automatic, Open Transition IQ Transfer (ATC-600) Logic.
 ② CTVISP: Automatic, Closed Transition IQ Transfer (ATC-800) Logic.
 ③ NTVISP: Non-Automatic, Electrically Operated, Open Transition Solid State Logic.
 ④ Mini-SPB only.
 ⑤ 4-Pole not available.

Switch and Feature Selection, Continued

Transfer Switch Features

Feature Numbers indicated with an asterisk (*) are part of Feature Group 9.

Description	Feature Number	ATVISP Automatic Open Transition	CTVISP Automatic Closed Transition	NTVSSP Non-Automatic Open Transition
Source Monitoring-Normal Power (All Phases)				
Under Voltage Sensing – All Phases	–	S	S	–
Over Voltage Sensing – All Phases	26C	O	O	–
Under Frequency	26E	O	O	–
Over Frequency	26F	O	O	–
Go to Emergency Rate (Area Protection)	26D	O	O	–
Phase Rotation	26H	O	O	–
Source Monitoring-Emergency Power				
1-Phase, Under Voltage/Under Frequency	5B*	S	S	–
1-Phase, Over Voltage/Over Frequency	5C	O	O	–
Phase Rotation	5H	O	O	–
3-Phase, Under Voltage/Under Frequency	5J*	S	S	–
3-Phase, Over Frequency and Over Voltage Sensing	5K	O	O	–
Time Delays				
Time Delay Normal to Emergency (TDNE)	1*	S	S	–
Time Delay Emergency to Normal (TDEN)	3*	S	S	–
Time Delay Engine Start (TDES)	2*	S	S	–
Time Delay Engine Cooldown (TDEC)	4*	S	S	–
Time Delay Emergency Fail (TDEF)	7*	S	S	–
Bypass TDEN Pushbutton	8C	O	O	–
Bypass TDNE Pushbutton	8D	O	O	–
Pre-transfer Signal Contacts (Elevator Control), up to 10 Devices	35A	O	O	–
Cranking Limiter	30A	O	O	–
Test Operators and Selector Switches				
Programmable Engine Test	6	S	S	–
System Selection	–	S	S	–
Maintenance Selector Switch	9B	O	O	–
Preferred Source Selector Switch Utility/Utility or Utility/Generator	10B	O	O	–
Preferred Source Selector Switch Generator/Generator	10D	O	O	–
Pushbutton Return to Normal	29E	O	O	–
Relay Auxiliary Contacts				
Relay Auxiliary Contacts	14C* and 14D*	S	S	–
Indicating Lights				
Position Indicators	12C* and 12D*	S	S	O
Source Availability Indicators	12G* and 12H*	S	S	O
Preferred Source Indicators	–	S	S	–
Load Energized Indication	–	S	S	–
History Display				
Source Availability Time	–	S	S	–
Source Run Time	–	S	S	–
Source Connected Time	–	S	S	–
Load Energized Time	–	S	S	–
Number of Transfers	–	S	S	–
Date, Time and Reason for Last 16 Transfers	–	S	S	–
Viewable Set Points				
Digital Display	–	S	S	–
Real-Time Clock				
Real-Time Clock	–	S	S	–
Integral Overcurrent Protection^①				
Digitrip – Both Sources	16B	O	O	O
Digitrip – Normal Source	16N	O	O	O
Digitrip – Emergency Source	16E	O	O	O
Service Entrance Rating (Requires Feature 16B or 16N)				
Service Entrance without Ground Fault Protection	37A	O	O	O
Service Entrance with Ground Fault Protection	37B	O	O	O

① Digitrip 510 Standard with Optional Feature 16. Digitrip 610, 810, 910, and OPTIM 750, 1150 also available. Contact Factory. S = Standard, O = Optional.

Switch and Feature Selection, *Continued*

Transfer Switch Features

Description	Feature Number	ATVISP Automatic Open Transition	CTVISP Automatic Closed Transition	NTVSSP Non-Automatic Open Transition
High Withstand Rating (100 kA at 480 Vac)				
600 to 1200 Amperes	17C	O	O	O
1600 to 4000 Amperes	17C	S	S	S
Plant Exerciser – Solid State Digital				
Plant Exerciser with Fail Safe	23J	O	O	–
Battery Chargers (For Separate Mounting)				
5A, 12 Vac Output – Requires 120 Vac Source	24C	O	O	O
5A, 24 Vac Output – Requires 120 Vac Source	24D	O	O	O
Load Transitioning (Inductive Motors and Transformers)				
Delayed Transition – Timer (Time Delay Neutral)	32A	O	–	–
Delayed Transition – Load Voltage Decay	32B	O	–	–
In-Phase Monitor, Load Voltage Decay	32C	O	–	–
In-Phase Monitor, Time Delay Neutral Timer	32D	O	①	–
Load Control				
Load Sequencing, up to 10 Devices	45	O	O	–
Load Shed from Emergency (Remote)	36	O	O	–
Metering				
Integrated Digital Meters				
Voltage – Normal, Emergency, Load	–	S	S	–
Frequency – Normal, Emergency	–	S	S	–
IQ Generator (Volts, Amperes, Frequency)				
Normal Source	18I	O	O	O
Emergency Source	18J	O	O	O
Both Sources	18K	O	O	O
IQ DP 4000 Microprocessor Metering Package				
Normal Source	18R	O	O	O
Emergency Source	18S	O	O	O
Both Sources	18T	O	O	O
IQ Analyzer Power Quality Metering Package				
Normal Source	18O	O	O	O
Emergency Source	18P	O	O	O
Both Sources	18Q	O	O	O
PowerNet Communication				
PowerNet System	②	O	O	–
Remote Alarm Contact				
Remote Alarm Contact	–	S	S	–
Space Heater with Thermostat (Requires separate 120V Power Supply)				
100 Watts	41A	O	O	O
200 Watts	41B	O	O	O
400 Watts	41C	O	O	O
Rear Bus Connections				
Rear Bus Connections	20A③	O	O	O
Non-Standard Terminals				
Non-Standard Terminals	21A	O	O	O
Logic Extender Cable				
48 Inches (1219.2 mm)	34A	O	O	O
72 Inches (1828.8 mm)	34B	O	O	O
96 Inches (2438.4 mm)	34C	O	O	O
120 Inches (3048.0 mm)	34D	O	O	O
144 Inches (3657.6 mm)	34E	O	O	O
Closed Transition (Operation Sequence)				
Closed, Alarm	47D	–	④	–
Closed, In-Phase, Load Voltage Decay	47C	–	④	–
Seismic Zone 4 Certification				
Seismic Zone 4 Certification	42	S	S	S

① Included as standard in Closed Transition with Feature Set 47C.
② Contact Factory.

③ Not available on Mini-SPB.
④ CTVISP must be selected with either 47C or 47D.

S = Standard, O = Optional.

**Dimensions and Weights —
Mini-SPB Fixed Mount**

**Automatic, Non-Automatic and
Manual Transfer Switches**

Enclosures meet all current applicable NEMA and UL standards for conduit entry, cable bending, gutter space and shielding of live components.

Available Enclosures

- NEMA 1
- NEMA 3R
- NEMA 4
- NEMA 4X
- NEMA 12

NEMA 1 Enclosures

NEMA 1 Transfer Switches are supplied with a front door only. They can be mounted in corner or against a wall.

All mini-SPB enclosure designs feature front cable access.

Transfer Switch Rating

Description	Weight Lbs. (kg)
3-Pole, 600-1200 Amperes	850 (386)
4-Pole, 600-1200 Amperes	950 (431)

Dimensions in Inches (mm)

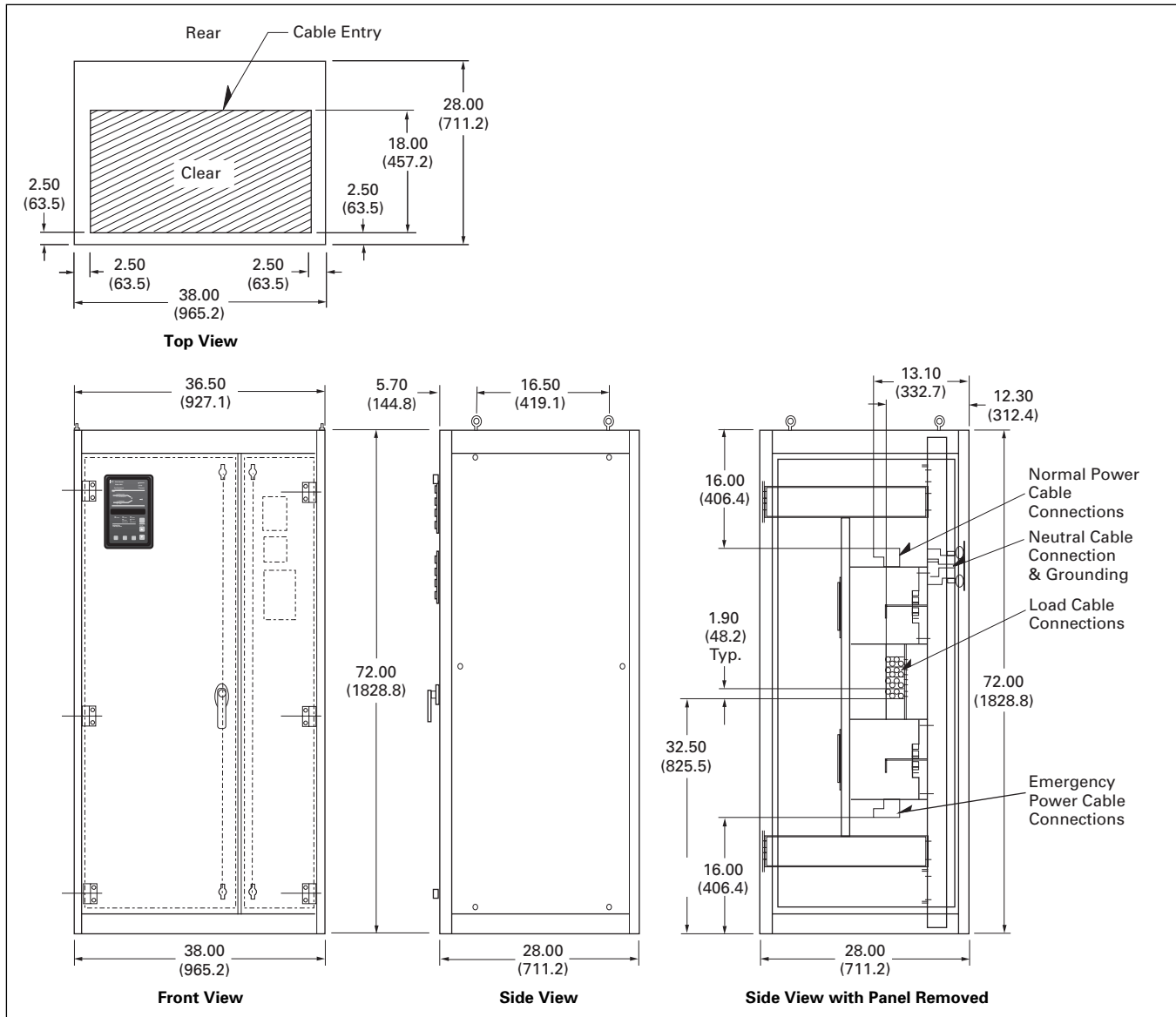

Dimensions are approximate in inches (mm) and should not be used for construction purposes.

**Dimensions and Weights —
SPB Fixed Mount and Drawout
Transfer Switches**

**Automatic, Non-automatic and Manual
Transfer Switches**

Enclosures meet all current applicable NEMA and UL standards for conduit entry, cable bending, gutter space and shielding of live components.

NEMA 1 Enclosures

NEMA 1 Transfer Switches are supplied with a front door only. They can be mounted in corner or against a wall. Access to cable space can be via either side, bottom, top, or the rear.

NEMA 3R Enclosures

Additional 2-inch (50.8 mm) clearance on each side of enclosure for hooded vent patterns.

Requires appropriate rear-end clearance based on 26-34-inch (660.4-863.6 mm) door (800-2000 amperes) or 24-inch (609.6 mm) double doors (2500-4000 amperes).

NEMA 3R Transfer Switches are supplied with front and rear doors. They can be mounted against a wall (allowing for hooded vent pattern clearance) but not in a corner. Access to cable space is via rear only.

Note: When open switch is mounted in customer enclosure, a vent pattern similar to that used on a Cutler-Hammer enclosure must be utilized.

Dimensions in Inches (mm)

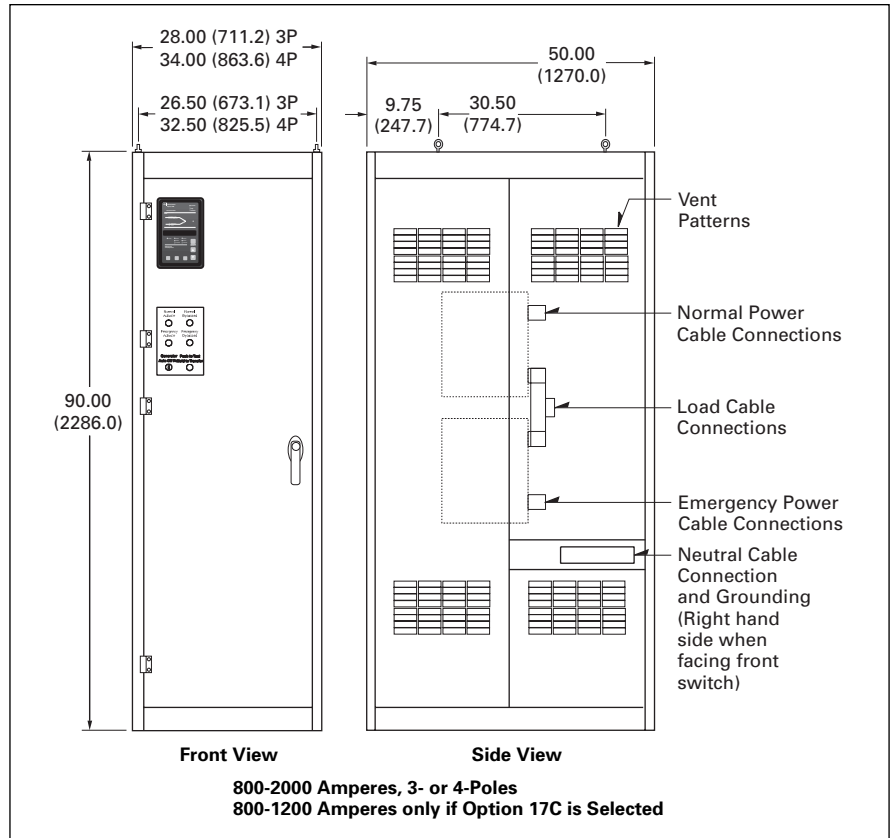

Dimensions are approximate in inches (mm) and should not be used for construction purposes.

Dimensions and Weights — SPB Fixed Mount and Drawout Transfer Switches, *Continued*

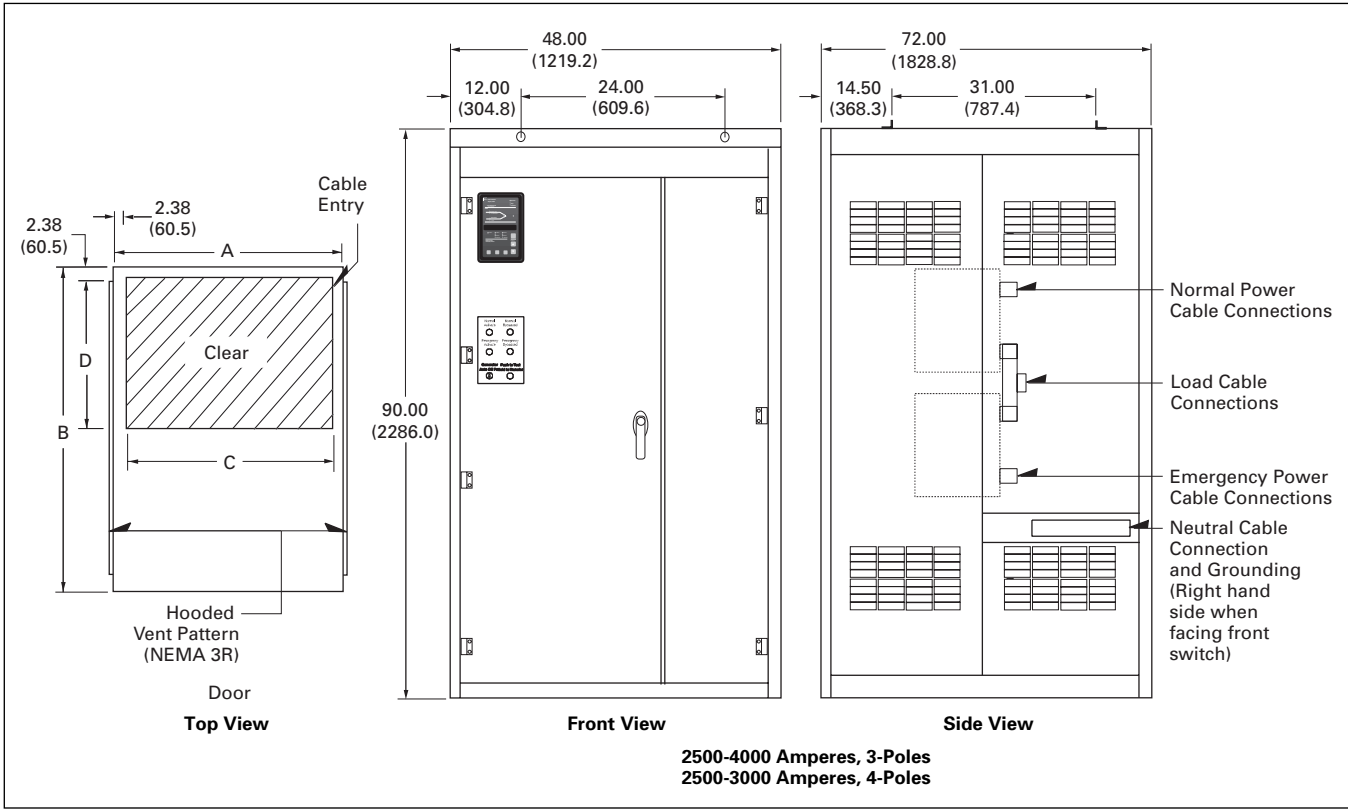

Dimensions and Weights

Transfer Switch Ampere Rating	Dimensions and Conduit Openings in Inches (mm)				Weight Lbs. (kg)	
	A	B	C	D		
3-Pole						
800-2000 ^①	Fixed	28.00 (711.2)	50.00 (1270.0)	23.50 (596.9)	22.00 (558.8)	1300 (590)
	Drawout		60.00 (1524.0)		28.40 (721.4)	1650 (749)
2500-4000	Fixed	48.00 (1219.2)	60.00 (1524.0)	43.25 (1098.6)	22.00 (558.8)	1900 (863)
	Drawout		72.00 (1828.8)		33.80 (858.5)	2200 (999)
4-Pole						
800-2000 ^①	Fixed	34.00 (863.6)	50.00 (1270.0)	29.50 (749.3)	22.00 (558.8)	1400 (636)
	Drawout		60.00 (1524.0)		28.40 (721.4)	1900 (863)
2500-3000	Fixed	48.00 (1219.2)	60.00 (1524.0)	43.25 (1098.6)	22.00 (558.8)	2100 (953)
	Drawout		72.00 (1828.8)		29.60 (751.8)	2400 (1090)

① 800-1200 amperes supplied with Option 17C.

Dimensions are approximate in inches (mm) and should not be used for construction purposes.

Copyright Cutler-Hammer Inc., 2001.
All Rights Reserved.