



Instructions for Cutler-Hammer Maintenance Bypass Switch

Catalog Numbered Units MBS

The Cutler-Hammer Maintenance Bypass Switch (MBS) is a closed transition switching device for use in conjunction with Uninterruptable Power Supply (UPS) equipment to maintain total continuity of power to connected load circuits when bypass of the UPS equipment is required for maintenance purposes.



WARNING

THIS PRODUCT CONTAINS A SPECIAL CONTACT ARRANGEMENT (OVERLAPPING CONTACTS). MISUSE CAN RESULT IN DEATH, SEVERE PERSONAL INJURY OR PROPERTY DAMAGE.

THIS PRODUCT CAN BE USED ONLY WITH A SINGLE SOURCE POWER SUPPLY. CUTLER-HAMMER IS NOT LIABLE FOR THE MISAPPLICATION OR MISINSTALLATION OF ITS PRODUCTS.

Description

The Cutler-Hammer MBS switching panel consists of two (2) molded case switches interconnected by a unidirectional, motor driven transfer mechanism to achieve closed transition (make-before-break) switching between the power supply originating from the load side of the UPS equipment (Normal) and directly from the utility power supply (Bypass) originating upstream of the UPS equipment (Figure 1). The MBS is also supplied with its own control panel which provides operating voltage for transfer as permitted by a logic signal originating in the UPS controls. The MBS switching panel and control panel are interconnected by a keyed harness plug connector. A control device panel is mounted to the enclosure door of the MBS which permits local electrical operation to the normal or bypass positions via pushbuttons and also provides local status indication via pilot lights.

Installation

The Cutler-Hammer MBS is factory wired and tested. Installation simply requires mounting and connection of service cables and the lockout control circuit from the UPS.

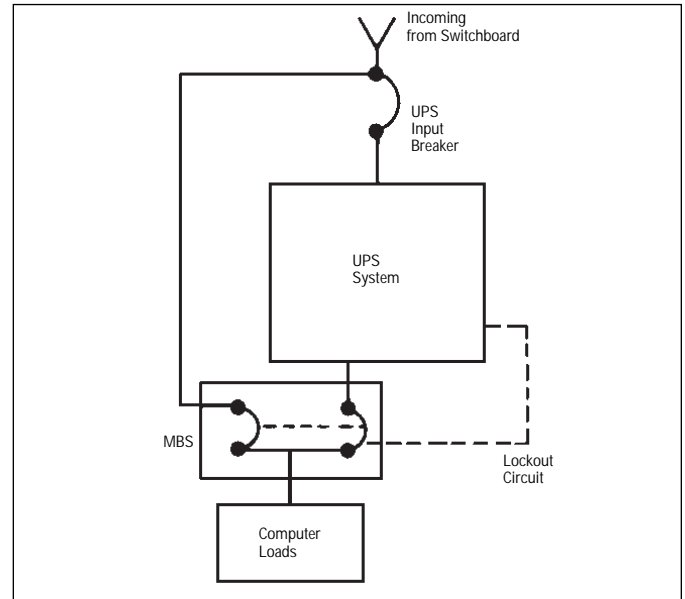

Figure 1 Application with Static UPS System

NOTICE

Protect the switch from construction grit and metal chips during the installation process.

Mounting

Mount the MBS enclosure vertically to a rigid supporting structure. Level all mounting points by using flat washers behind the holes to avoid forced distortion of the enclosure. See Figure 2 for mounting dimensions.



WARNING

DO NOT MAKE ANY POWER OR CONTROL CIRCUITRY CONNECTIONS BEFORE DE-ENERGIZING SUCH CONDUCTORS. MAKE SURE THAT NORMAL AND BYPASS POWER CONNECTIONS ARE IN PROPER PHASE ROTATION. IMPROPER POWER CONNECTIONS OR FAILURE TO INSURE DE-ENERGIZATION OF SUCH CONDUCTORS CAN RESULT IN DEATH, SEVERE PERSONAL INJURY, OR PROPERTY DAMAGE.

Power Connections

All power cables should enter enclosure adjacent to the solderless screw type lug terminals provided for connection to the MBS. Route cables to the side of the enclosure making sure that such cables will not interfere with the MBS operation or block components of unit from access for maintenance or inspection purposes. Tighten cable lugs to the torque specified on the label provided on MBS panel immediately adjacent to such lugs. See Figure 2 for typical power cable interconnections and Table 1 for terminal data.



CAUTION

THIS PRODUCT MUST INTERFACE WITH A LOGIC SIGNAL PROVIDED BY THE UPS CONTROLS WHICH PERMITS ELECTRICAL OPERATION OF MBS ONLY UNDER CERTAIN CONDITIONS. FAILURE TO INTERFACE MBS WITH THE UPS LOGIC SIGNAL CAN RESULT IN PERSONAL INJURY OR PROPERTY DAMAGE.

UPS Logic Lockout Circuit Connection

The control circuit conductors originating from the UPS lockout controls should enter the enclosure adjacent to the red solderless, screw-type terminal blocks marked T1 and T2. These terminal blocks are located on the MBS control panel in the lower right corner of the enclosure. Refer to UPS instructions for identification and location of the lockout circuit interconnections within the UPS controls.

Table 1 Power Cable Terminal Data

No. Cables Per Phase	Wire Size Range
1	#6 - 1/0
1	#3 - 350 MCM
2	250 - 500 MCM
2	#1 - 500 MCM
3	3/0 - 400 MCM
4	4/0 - 500 MCM

Operation

The MBS is electrically operated via pushbutton (PB) operators locally mounted on a pilot device panel on the enclosure door.

NOTICE

Electrical operation of the MBS is inhibited by the lockout contact supplied from the UPS logic.

Electrical operation of the MBS is permitted by the UPS logic when the lockout contact is opened. Opening of the UPS lockout contact will de-energize the KL relay and thereby enable the PB operators. Depressing the PB marked "Bypass" will energize relay KB causing the MBS motor transfer mechanism to operate the molded case switches, transferring the connected load on a make-before-break basis to the bypass position. If the lockout signal originating in the UPS controls permits, retransfer back to the normal UPS power position is similarly accomplished by depressing the PB marked "Normal" which will permit relay KN to energize, causing the transfer of connected load circuits back to the normal UPS power supply. The transfer motor circuit, once energized is broken by the opening of the appropriate limit switch (NLS or BLS) contact. Voltage for transfer and controls is taken from a common 120 VAC power source originating from either the normal transformer (NT1) or bypass transformer (BT1) as selected by the voting relay KV. Three (3) pilot lights are supplied on the enclosure device panel:

1. Normal (Green) - Indicates MBS is on normal UPS power.
2. Bypass (Green) - Indicates MBS is on bypass power
3. Lockout (Red) - Indicates presence of UPS lockout signal and MBS operation is inhibited.

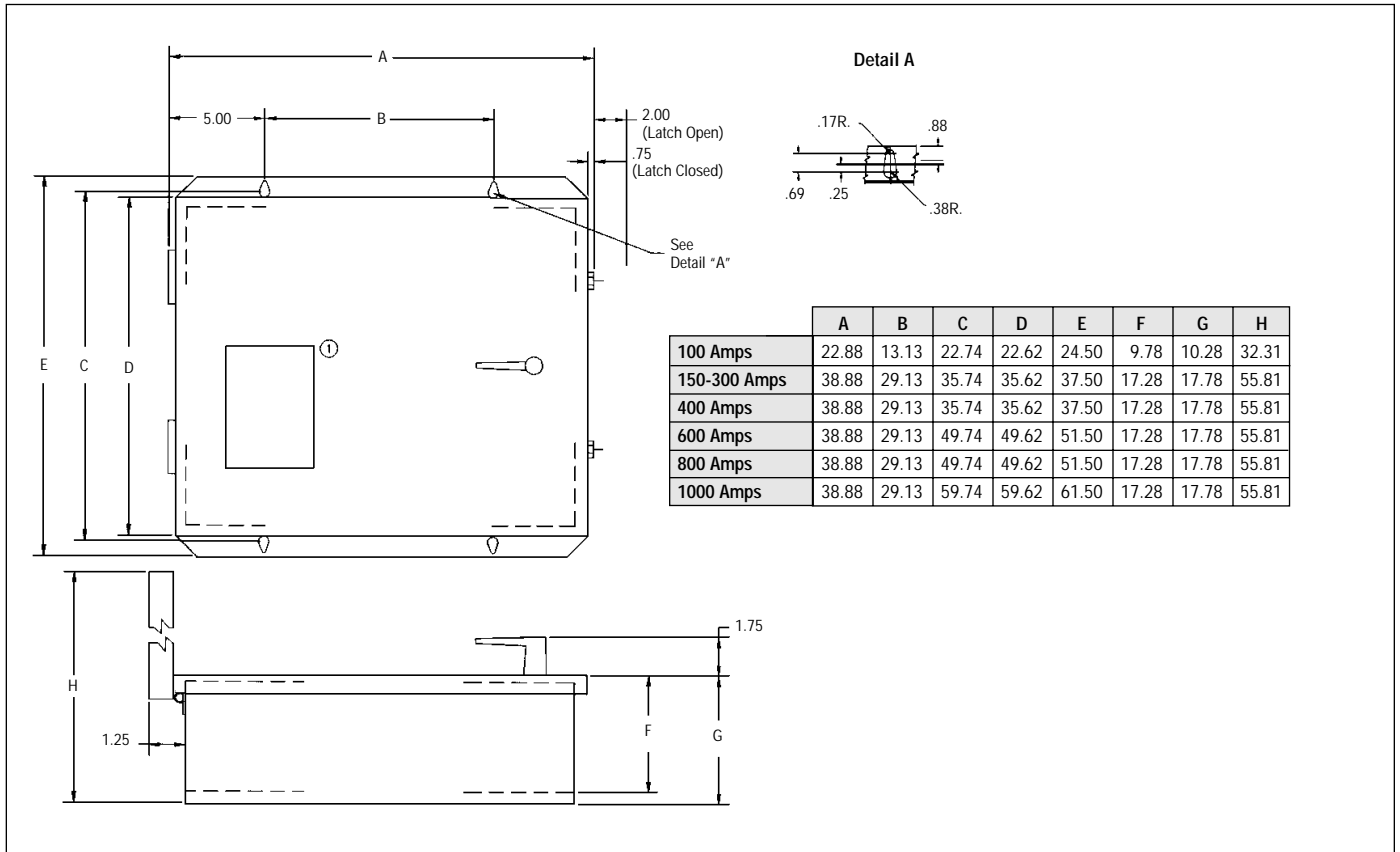

Figure 2 Outline Dimensions

Cutler-Hammer
Pittsburgh, Pennsylvania U.S.A.

Effective 12/98 (ISI)
Style 5724B23H01
Printed in U.S.A.

