

Peaking Switches

Index	Page
General Description	2
Applications	2
External Connections	2
Sequence of Operation	3
Protection	3
Technical Specifications	3
Components	3
Communications	6



General Description

Previously installed engine generator sets with existing open or closed transition automatic transfer switches cannot be continuously connected (paralleled) to the utility source. The main problem is that transfer switches are mechanically and electrically interlocked to prohibit simultaneous power flow through both the normal and emergency sides.

The Cutler-Hammer Peaker switch is a product that works with the existing engine and transfer switch and solves this problem by providing a safe bypass path for generator energy to flow onto the load bus, even while the load is fed from the normal (utility) source.

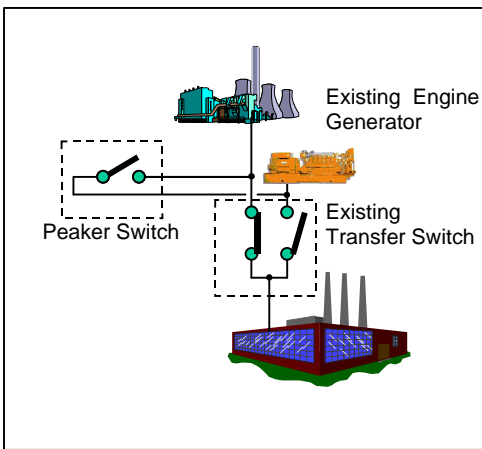

Applications

Cutler-Hammer peaking switches are designed as inexpensive retrofit solutions to convert existing open or closed transition transfer switches into full time capable paralleling systems.

As the peaker switch only includes one switching device (for the generator), it cannot disconnect the utility main when the generator is operating. For standby service applications, you must disconnect the utility to prevent backfeeding power when utility power is lost. For this reason, the peaker switch is nearly always used as a retrofit product to an existing transfer switch.

For new applications that require peak shaving *and* standby service, refer to the Cutler-Hammer Soft-Load Closed-Transition Transfer Switch (see CH publication TD.15A.04B.T.E). The Cutler-Hammer peaker switch supports multiple, paralleled generator sets by including:

- Dead Bus Closing Protection
- Isochronous Load Sharing

Dead Bus Closing Protection

To prevent out of phase closure between two sources, the Cutler-Hammer peaker switch includes a sync check (IEEE Device

25) function. This function monitors the voltage, phase and frequency across the peaker switch power switching device. If the two sources are not matched, the sync-check function prevents the peaker switch from closing. In the special case of one side of the peaker switch being dead (zero volts), the peaker switch can close at any time since there can not be an out-of-phase closure.

However, in the case of multiple generators attempting to simultaneously close to a common bus, you must include provisions to prevent two sources from simultaneously closing to what they think is a dead bus but milliseconds later becoming energized.

The Cutler-Hammer Peaking Switch accomplishes the Dead Bus Closing Protection by connected a twisted shielded pair of cable between each Peaking Switch. This cable permits each switch to communicate using the Echelon Lonworks™ protocol and allows a “dead bus token” to be passed to each peaker switch in turn. Only the station that presently possesses the token may close to the bus.

Isochronous Load Sharing

When two or more generators are connected to a common bus, they each share a portion of the load. Without a load balancing signal connected between the generators, the engines will not equally share to load. The result is that one generator could become prematurely overloaded.

If the generators were perfectly balanced, one would expect that:

- 2 generators each share 50% load
- 3 generators each share 33% load
- 4 generators each share 25% load
- etc.

Practically speaking, generators cannot be perfectly balanced. To compensate for this mismatch in capacity, the Cutler-Hammer Peaking Switch connects a second twisted pair cable. This second twisted pair transmits a signal that represents the total loading of the system. Individual Peaking Switches use this line to balance their output so each generator is equally loaded.

Reverse Power (Islanding Protection)

When a generator produces more output than can be consumed by the connected loads, the excess power must travel through the utility service entrance and onto the utility distribution system. This constitutes a safety hazard and is specifically prohibited by utilities.

To prevent this, many utilities require additional protective relaying at the customer service entrance. The requirements vary by utility, but typically the relays required include:

- 32 Reverse Power
- 27 Undervoltage

- 59 Overvoltage
- 81U Underfrequency
- 81O Overfrequency

Unless the current flow through the service entrance connection approached zero at the time of the loss of the utility voltage, these relays will detect the loss by noting a change in bus frequency or voltage. For applications that must guarantee tripping of the customer service entrance breaker, some utilities specify that a “transfer trip” scheme be employed. A transfer trip scheme connects the customer service entrance breaker to the utility substation breaker or recloser. If the utility substation breaker or recloser opens, the transfer trip system sends a remote trip signal to the customer’s service entrance breaker, tripping that customer off line.

Transfer trip systems are expensive. Plus they are not needed unless the nominal current through the service entrance approaches zero. As a result, many engineers use conventional protective relays before resorting to transfer trip.

External Connections

The Peaking Switch requires these field connections:

- 3-phase to generator
- 3-phase to “normal” bus
- One twisted pair to governor
- One twisted pair to voltage regulator
- Contact closure, engine start
- One twisted, shielded pair for Load Share
- One twisted shielded for Dead Bus Control
- (Optional) Modbus (RS-232 or RS-485) or Lonworks (FT-10 78 kbps) to SCADA system

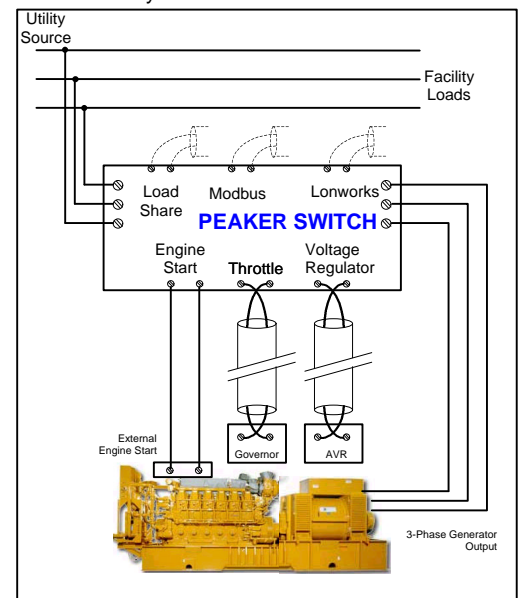

Sequence of Operation

The Cutler-Hammer peaking switch, in response to the closing of an external dry contact, starts the engine and parallels it to the utility when a contact is closed. This contact can originate from a variety of sources:

- Output from PLC, TouchTone™ activated switch or SCADA RTU
- Selector switch (Peaking Mode Enable) on front panel of peaking switch
- Via command received on the Modbus or Lonworks network connections on the peaking switch

Regardless of the method, the sequence of operation after this contact is closed is detailed below.

Peaking Operation - Start

1. Peaking switch receives command to start (e.g. move "Peaking Mode" selector switch to enable position).
2. Separate engine start contact wired from peaker switch to the generator is closed by peaker switch.
3. Peaking switch waits until generator voltage and frequency are within tolerance of the utility at which point the bypass switching device closes.
4. The peaking switch sends commands (analog output) to the generator governor and voltage regulator to incrementally increase the load on the generator to export power up to the user selected limit. (Signals sent to governor and voltage regulator are available in a variety of analog or PWM signals -- specify based governor and voltage regulator installed before ordering Peaker Switch.)

Peaking Operation - Stop

1. Peaking switch loses signal commanding it to start (e.g. move "Peaking Mode" selector switch to disable position).
2. The generator is unloaded in incremental steps until the generator output is below a user selectable disconnect set point.
3. The bypass switching device opens.
4. The generator runs until the Cool-Down timer expires.
5. The generator engine is shut down.

Loss of generator or normal source while in parallel to the normal source

1. A protective relay internal to the peaking switch trips.
2. The bypass switching device opens.
3. The peaking switch switches to lockout mode. The existing automatic transfer switch now controls the generator exclusively. In this mode, the system reverts to its mode of operation before the peaking switch was installed. The generator will provide power to the load until the utility is restored, at which time the transfer switch (after a Time Delay

Emergency to Normal -- provided in ATS) switches back to normal source power. Note that the lockout mode requires user intervention to reset and should only be done once the connection to utility power is restored.

Protection

The Cutler-Hammer peaker switch provides ANSI C37.90-1989 3-phase protective relay functions for the generator:

- 25 Sync Check
- 25A Automatic Synchronization
- 27 Undervoltage
- 32 Reverse Power (W, VA, var)
- 40 Loss of Field (32 var)
- 46 Neg. Seq. Overcurrent
- 47 Neg. Seq. Overvoltage
- 51V Volt restrained overcurrent
- 59 Overvoltage
- 81 Over/under frequency

The peaker switch is supplied with four CT and four PT inputs. The fourth CT input operates in two modes:

- 1-phase current input
- Load Share line

The Load Share line is only needed when 2 or more generators are paralleled to a common bus. When only one generator is used, the fourth CT input can be configured for additional relay protection for the utility connection. This protection includes (all 1-phase):

- 27 Undervoltage
- 32 Reverse Power (W, VA, var)
- 59 Overvoltage
- 81 Over/under frequency

If the customer wishes to provide additional utility protection, they can choose whether to supply the 3-phase protection on the utility or the generator or they may request an additional protective relay such as:

- Cutler-Hammer FB-5000
- Beckwith M-3520 or M-3410
- Basler BE1-951
- Schweitzer SEL-351

When combined with the protection offered by a main breaker (50, 51, 50G, 51G, 50N, 51N), this relaying can provide islanding protection (detecting then separating when utility fails).

When paralleling two or more generators to a common bus, one solution to provide islanding detection is to install a new protective relay at the customer main breaker. Another option is to install a "Soft-Load" transfer switch upstream from the existing main breaker. The Cutler-Hammer Soft Load Transfer Switch provides the protective functions necessary to provide islanding protection. Refer to Cutler-Hammer publication TD.15A.04B.T.E for more information on the CH Soft-Load Closed-Transition transfer switch.

Note that utilities having jurisdiction may require that not only particular relay functions be installed, they may insist on a particular brand of protective relay(s). As the protective relaying provided by the Cutler-Hammer peaking switch is an integral part of the switch, it cannot be removed for credit. Cutler-Hammer will install the additional relay(s) required by the utility, but this relaying is redundant and increases the cost of the peaking switch. Cutler-Hammer will work with a utility to discuss in detail the protective relaying provided.

Technical Specifications

Standards

- UL508 listed Industrial Control Panel
- UL891 Dead Front Switchboards
- CUL

Seismic

With proper installation and by including the appropriate option which includes specially designed cleats (required for floor standing units over 800A), a Peaking Switch has a seismic capability which exceeds the worst case Zone 4 required levels per both the Uniform Building Code and the California Building Code.

Operating Conditions

NEMA 1 enclosure specified: Normal operation in an electrical equipment room for indoor applications.

NEMA 3R enclosure specified: Outdoor applications subject to falling rain, freezing temperatures, 95% humidity (non-condensing).

Ambient temperature for operation between -20° and +65°C.

Power Requirements

18-75 Vdc (<10 W)
85-265 Vac (<25 W)

The Cutler-Hammer peaker switch is supplied with a built-in 24 Vdc battery and charger. The 24 Vdc power supply provides sufficient power to maintain peaker switch operation for a minimum of 2 hours following a complete power outage.

This battery can be optionally connected in a best battery arrangement with the existing engine cranking batteries. A battery charger is supplied that maintains full charge on the built-in battery. An automatic control voltage selector connects the charger to either utility or generator bus voltage depending on which is available.

Components

The Peaking Switch is offered in two designs:

- Contactor based (400A, 540A designs)

- Stored energy breaker based (800A to 4000A designs)

The *contactor based designs* are wall mounted units with these dimensions (NEMA 1):

400 - 540A

- 52" (1320 mm) H
- 21" (533 mm) W
- 17" (432 mm) D



Available space for IQ Analyzer or other metering or relaying

Front panel operator interface (HMI)

540A Wall mount Peaker Switch

The *stored energy breaker designs* are floor mounted designs (rear access required -- these cannot be mounted flush with a wall) NEMA 1:

800A - 2000A

- 90" (2270 mm) H
- 34" (864 mm) W
- 61.75" (1570 mm) D

2500A - 4000A

- 90" (2270 mm) H
- 48" (1220 mm) W
- 73.75" (1870 mm) D

Front accessible designs (28" depth) are available up to 1200A. Certain restrictions

apply to available options for these "mini" designs.

Annunciators/HMI

Each peaker switch includes a password protected local human machine interface (HMI) that provides monitoring, control override and setpoint access.



The standard display includes a 4 line by 20 character display capable of displaying up to 4 parameters at a time (e.g. Vab, Vbc, Vca, plus Average V).

Values that can be displayed include:

- Voltage (A, B, C and average)
- Currents (A, B, C and average)
- Frequency (1/100 Hz resolution)
- Power Factor
- kW, kvar, kVA
- % voltage imbalance
- % current imbalance
- Runtime
- Status
- Digital Input Status
- Digital Output Status
- Voltage bias output
- Frequency bias output

Through the HMI, the protective relay settings are viewed and changed.

540A Peaker Switch - Interior View

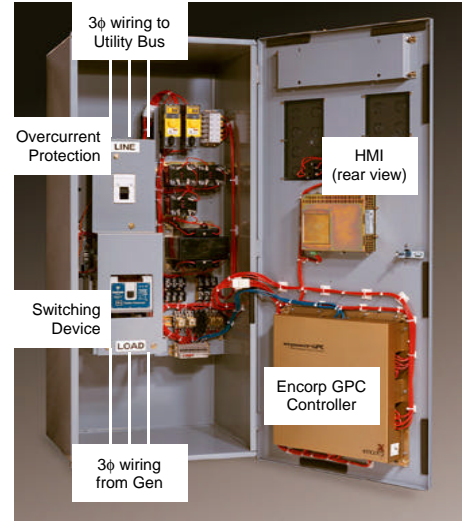

Protective Relay Settings

3-phase Voltage Relay (27/59)

- Hi Hi voltage and hysteresis
- Hi voltage and hysteresis
- Lo voltage and hysteresis
- Lo Lo voltage and hysteresis
- Set Time (Lo and Hi)
- Set Time (Lo Lo and Hi Hi)
- Clear Time (Lo and Hi)
- Clear Time (Lo Lo and Hi Hi)

Power Relay 1 (32): W, var, VA

- Hi Hi power and hysteresis
- Hi power and hysteresis
- Lo power and hysteresis
- Lo Lo power and hysteresis
- Set Time (Lo and Hi)
- Set Time (Lo Lo and Hi Hi)

Multiple Peaker Switches Connection Diagram

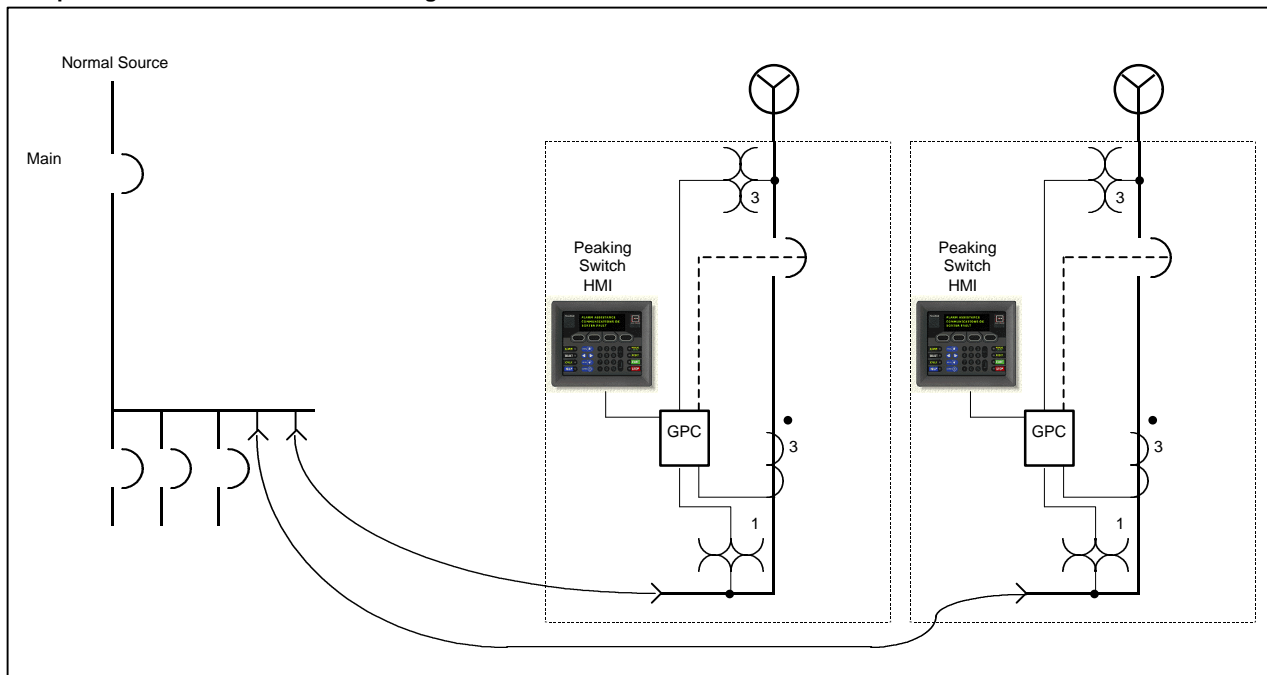

- Clear Time (Lo and Hi)
- Clear Time (Lo Lo and Hi Hi)

Power Relay 2 (32): W, var, VA

- Hi Hi power and hysteresis
- Hi power and hysteresis
- Lo power and hysteresis
- Lo Lo power and hysteresis
- Set Time (Lo and Hi)
- Set Time (Lo Lo and Hi Hi)
- Clear Time (Lo and Hi)
- Clear Time (Lo Lo and Hi Hi)

Typically the second reverse power relay is configured to measure vars. This provides loss of field (40) trip.

Negative Sequence Current (46)

- Hi Hi current and hysteresis
- Hi current and hysteresis
- Set Time (Hi)
- Set Time (Hi Hi)
- Clear Time (Hi)
- Clear Time (Hi Hi)

Negative Sequence Voltage (47)

- Hi Hi current and hysteresis
- Hi current and hysteresis
- Set Time (Hi)
- Set Time (Hi Hi)
- Clear Time (Hi)
- Clear Time (Hi Hi)

Voltage Restrained Overcurrent (51V)

- Hi current
- Rated voltage
- Set Time (Hi)
- Clear Time (Hi)

Generator Frequency Relay (81)

- Hi Hi Hz and hysteresis
- Hi Hz and hysteresis

- Lo Hz and hysteresis
- Lo Lo Hz and hysteresis
- Set Time (Lo and Hi)
- Set Time (Lo Lo and Hi Hi)
- Clear Time (Lo and Hi)
- Clear Time (Lo Lo and Hi Hi)

Alarms/Trips

As standard the Cutler-Hammer peaking switch is programmed with the second reverse power relay configured to monitor var direction flow. Loss of field (40) is annunciated as "Generator Lo Lo vars". See complete list of trip messages below:

- Generator Frequency Hi Hi
- Generator Frequency Hi
- Generator Frequency Lo
- Generator Frequency Lo Lo
- Generator Voltage Hi Hi
- Generator Voltage Hi
- Generator Voltage Lo
- Generator Voltage Lo Lo
- Generator kW Hi Hi
- Generator kW Hi
- Generator kW Lo
- Generator kW Lo Lo
- Generator vars Hi Hi
- Generator vars Hi
- Generator vars Lo
- Generator vars Lo Lo
- Generator V unbal Hi Hi
- Generator V unbal Hi
- Generator I unbal Hi Hi
- Generator I unbal Hi
- Generator Overcurrent
- Generator Failure
- Fail to Sync
- Breaker Fault

Pilot Lights

Standard lights are listed below. Can be deducted for credit or to simplify the front control panel. Letter following description corresponds to the color of the lens (Green, Red, White or Amber)

- Generator Breaker Open (G)
- Generator Breaker Closed (R)
- Engine Running (W)
- Control Fault (R)
- Control not in Auto (W)
- Alarm (A)
- Generator Power Avail (W)
- Fail to Sync (A)
- Sources Synced (W)
- Protective relay trip (R)

Control Switches

- Alarm Reset/Silence
- Auto/Test 2-position selector
- Auto Enable/Disable 2-position selector
- Initiate Test: Start/Normal 2-position spring return selector
- Alarm Horn: Enable/Disable

Other Settings

In addition to the settings listed above, several settings are available that usually do not require modification once the unit has been matched to the engine-generator set. The settings are configured during start-up and then not changed. To limit the likelihood of accidental modification of these additional settings, these settings are not displayed on the front panel HMI. They are configured using a laptop computer connected to the Lonworks network port (or optionally Modbus, contact CH for

Service Entrance Islanding Protection Provided by Soft-Load Transfer Switch

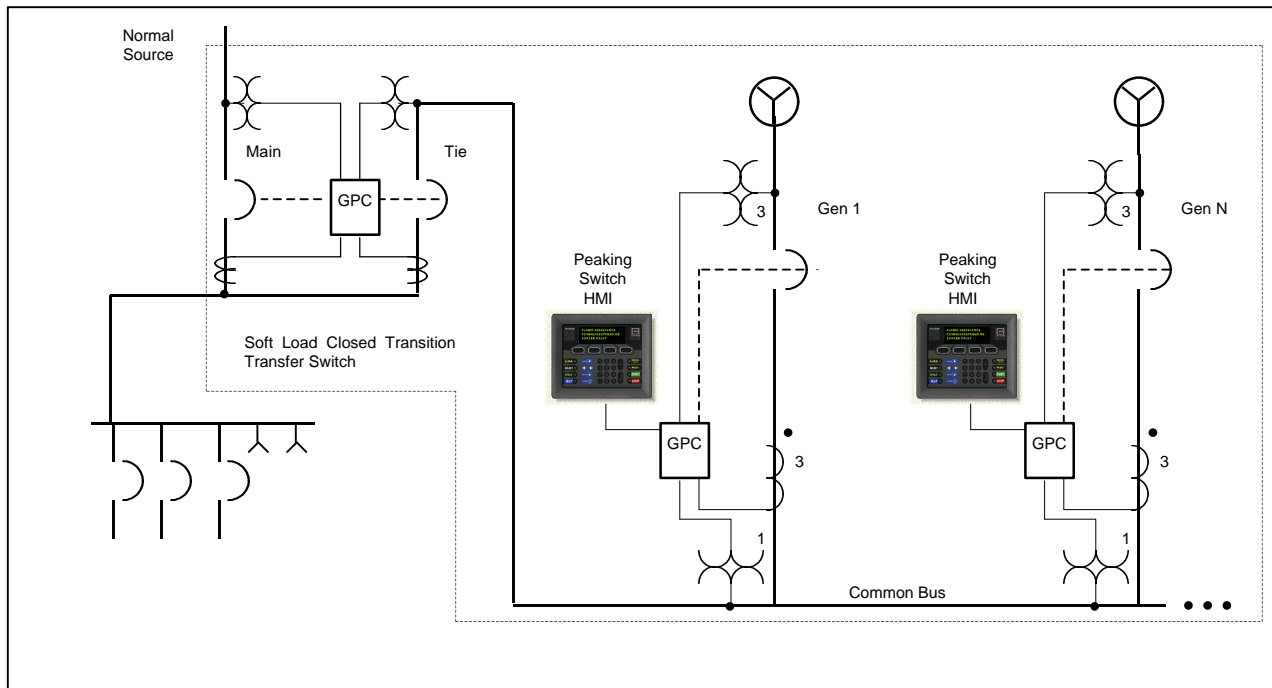

availability). Some of those settings include:

Load Share

- Max Gen kW
- Gen Baseload kW
- Gen Disconnect kW
- Raise-Lower rate kW/sec
- Proportional gain, Load share
- Proportional gain, Base load

25A Automatic Synchronizer

- Phase accept window (xx.xx degrees)
- Voltage accept window (xx.x V)
- Slip accept range (Hz/sec)
- Fail to Sync time
- Slip Freq. setpoint (Hz)
- Breaker close time (x.xx seconds)
- Dead bus delay (x.xx seconds)
- Synchronizer proportional gain (kp)
- Synchronizer integral gain (ki)
- Voltage match prop. gain (kp)
- Voltage match rate (V/sec)

Communications

The Peaker Switch as standard supports the following communications:

- Modbus RTU
 - RS-232 or
 - RS-485 2-wire
- Lonworks
 - FT-10 (78 kbps)

Optionally, these communications options can be added:

- Ethernet
 - Modbus TCP/IP
 - HTML (web server)
- Auto-answer / Auto-dial modem
 - Modbus RTU
- Touch-tone™ access
 - dispatch and monitor from telephone using synthesized voice prompting
- Lonworks RS-232
 - used for remote modem or dial-up access
- Modbus Plus (MB+)

Modbus

The Cutler-Hammer Peaking Switch supports these Modbus function codes:

- 1 - Read Coil Status
- 2 - Read Input Status
- 3 - Read Holding/Output Register
- 4 - Read Input Register
- 5 - Change Single Coil
- 6 - Change Single Holding Register
- 15 - Change Block of Output Bits
- 16 - Change Block of Holding Registers

Data are stored within standard 0xxxx, 1xxxx, 3xxxx and 4xxxx registers. 1xxxx and 3xxxx registers are considered read-only and are used to provide current operating status of the peaking switch. 0xxxx and 4xxxx are read-write registers and are used to store setpoints or to override signals within the peaking switch. Over 1000 registers are provided, covering

nearly every operational aspect of the peaking switch. Serial port parameters are fixed at 9600 bps, no parity and 1 stop bit (10 bit frame).

Modbus is a master-slave protocol that supports, as standard, one master with up to 247 slaves. Cutler-Hammer permits adding additional masters by including the Modicon BM-85 Bridge Multiplexer. This permits additional Modbus masters (such as remote SCADA terminals) to simultaneously access the Modbus slave communication port. BM-85 Bridge MUXs may be daisy-chained via their built-in Modbus Plus network to grant an arbitrarily large number of Modbus masters simultaneous access the peaking switch.

DDE and OPC servers are available for developing custom programs that interface with the Cutler-Hammer peaking switch. Modem, radio, microwave, fiber, twisted pair or infrared connections are available using Modbus.

Lonworks

The Cutler-Hammer peaking switch uses the FT-10 (Twisted Pair, Free Topology) 78 kbps implementation of the Echelon Lonworks network. This network supports up to 500 meters of twisted, shielded pair when configured with taps, or up to 1500 m when wired in a true daisy-chain (in and out from each node). The Cutler-Hammer peaking switch uses this Lonworks LAN for three primary purposes:

- Remote I/O
- Operator Interface
- Computer Interface (programming)

As Lonworks is a peer-to-peer network, an arbitrary number of nodes can be connected (subject to Lonworks 32000 nodes limitation) to the network using any combination of computers, peaking switches, remote I/O blocks or human machine interfaces (HMI). Connection can be directly to the twisted pair, or after converting to RS-232 using the SLTA-10, via modem, radio or line driver.

The connection from the FT-10 twisted pair to a computer, modem or other device is as follows:

- ISA bus use: PCLTA-10 card
- PCI bus use: PCLTA-20 card
- RS-232 use: SLTA-10 box
- PC Card (Type II) formerly PCMCIA use: PCC-10

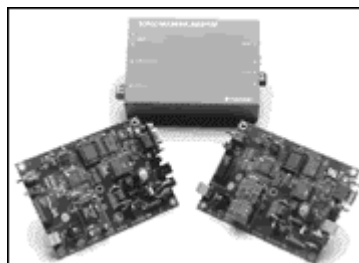

A DDE server is available for interfacing custom programs (VB, Delphi, Excel) that interface with the peaking switch.

Refer to www.echelon.com for more information on the Lonworks protocol.

Remote Access

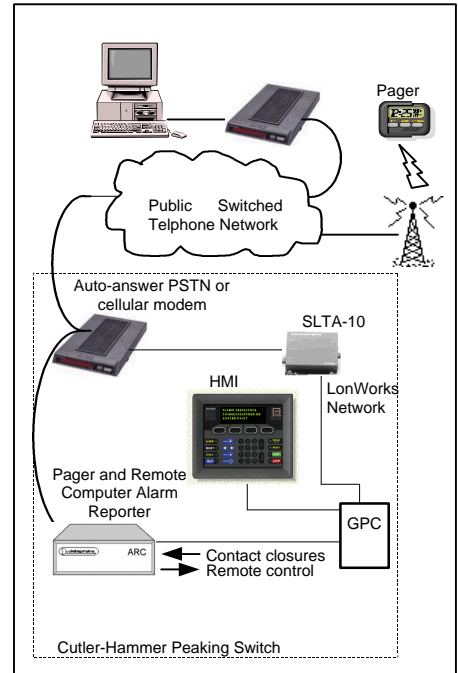

A variety of methods exist for remotely monitoring and controlling the peaking switch:

- Computer dial-in to Modbus slave port
- Computer dial-in to Lonworks port
- Computer dial-in to "Pager and Remote Computer Alarm Reporter"
- Operator through Touch-Tone™ control of peaking switch

Dial-In to Modbus

The peaking switch includes one (1) Modbus slave port. This port supports two addresses. One address (lower of two address pair) communicates with the built-in PLC control contained within the Encorp GPC. The second, higher address connects with the synchronizing, alarming and protective relay logic within the same GPC. For example:

- Modbus address 001 - GPC PLC
- Modbus address 002 - GPC controller

As standard, the peaking switch includes a local HMI to provide monitoring and local setpoint control functions. This HMI connects to the peaking switch via the Modbus port.

Modbus communication is the customary choice for users of commercial HMI or SCADA packages (such as Wonderware InTouch, Iconic Genesis or Intellution iFix).

If the application requires both local and remote access to the peaker, the peaking switch can be provided with two options:

- **Local or remote**
An optional push button on the peaker switch is pressed to select "local" operation. This switches the Modbus serial port to connect to the local HMI and disconnects the remote modem port. After a user selectable time delay, the Modbus port reverts to connecting to the modem port.
- **Local and remote**
Simultaneous access to the single Modbus port on the peaker switch from both a local HMI and a remote modem requires that the optional BM-85 Bridge Mux be installed.

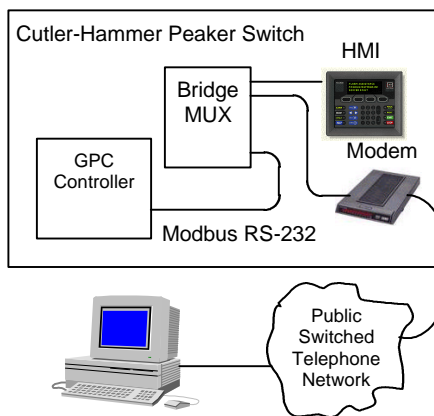

Dial-In to Lonworks

To provide a remote connection to the Lonworks twisted pair network, the Echelon SLTA-10 interface is installed. This external box converts the 78 kbps twisted pair

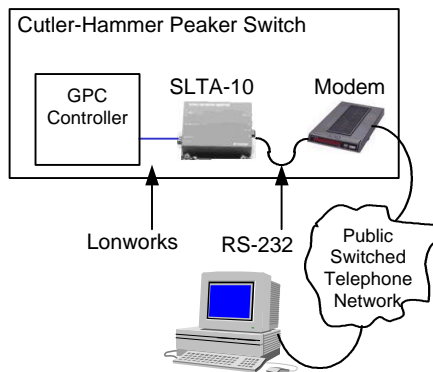

network into RS-232. The RS-232 baud is selectable from 1200 to 38400 bps. The RS-232 port from the SLTA-10 is connected to a modem. Both the modem and the SLTA-10 are connected to the same DC power source as the GPC to insure reliable operation during switching, engine starting and other transitory operations.

Cutler-Hammer software permits dialing into the Lonworks network and accessing all controller functions.

Dial-In to Pager and Alarm Responder

Dial-in applications imply that a remote computer takes the lead in initiating communications with a remote peaker switch. This is acceptable for periodic monitoring or for remote dispatching applications.

However, for more urgent notification requirements, it is desirable to have the peaker switch initiate the communications with the computer. Further, should the computer not answer or if the message must be simulcast to multiple sites (including alpha-numeric pagers), the ability to queue multiple alarms with time-stamping at the remote site is required.

To accomplish this, the peaking switch is configured with a "Pager and Remote Computer Alarm Reporter". This device includes a separate real-time clock and responds to contact closure signals which cause the unit to dial one or more numbers and deliver a message. If the number dialed is a computer, the message is sent to the computer based on what combination of input signals was triggered. The computer then can acknowledge this message by returning an acknowledge code. The receipt of the acknowledge code is then used by the peaker switch to determine if additional numbers are dialed or if the peaker switch terminates dialing until the next change in state of the input leads.

Direct Operator Control through Phone

The methods of accessing and controlling the peaking switch from a remote location discussed above have all required a computer at the remote location to control the peaker switch.

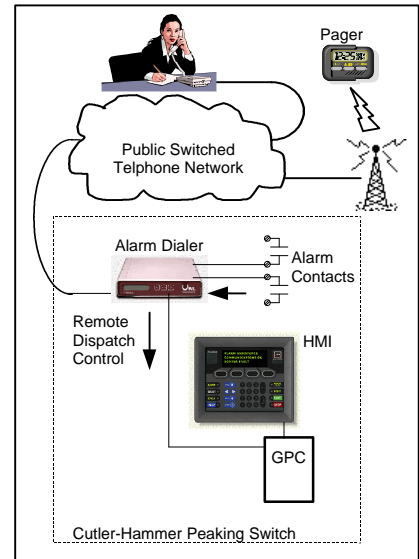

For applications that require remote control, but where a computer is not available or desired, specify the "Touch-Tone™ Alarm Dialer" option. This option mounts a device that connects to the phone line, plus monitors 8 digital points in the peaker switch. This option also permits the remote control of 3 outputs (dry contacts). As standard, one of the dry contact relays is wired such that when closed, it signals the peaker switch to initiate a peaking operation (engine start, parallel, close generator to bus). Two contacts are available as user configurable spares (example, "Start Engine Pre-Alarm Horn", etc.)

This unit also self-initiates a call to one or more phone numbers when one or more of the 8 digital inputs change state. The unit can transmit either a recorded voice message (example "North County Dairy Engine 1 Low Fuel") or can dial a numeric pager and transmit a sequence of recorded Touch-Tone™ tones previously recorded that appear as a sequence of numbers on the pager. This permits automatic dispatching of maintenance, helping increase uptime.