



Instructions for Cutler-Hammer Residential Automatic Transfer Switch





WARNING

READ AND UNDERSTAND THE INSTRUCTIONS CONTAINED HEREINAFTER BEFORE ATTEMPTING TO UNPACK, ASSEMBLE, OPERATE OR MAINTAIN THIS EQUIPMENT.

HAZARDOUS VOLTAGES ARE PRESENT INSIDE TRANSFER SWITCH ENCLOSURES THAT CAN CAUSE DEATH OR SEVERE PERSONAL INJURY. FOLLOW PROPER INSTALLATION, OPERATION AND MAINTENANCE PROCEDURES TO AVOID THESE VOLTAGES.

TRANSFER SWITCH EQUIPMENT COVERED BY THIS INSTRUCTION BOOK IS DESIGNED AND TESTED TO OPERATE WITHIN ITS NAMEPLATE RATINGS. OPERATION OUTSIDE OF THESE RATINGS MAY CAUSE THE EQUIPMENT TO FAIL RESULTING IN DEATH, SERIOUS BODILY INJURY AND/OR PROPERTY DAMAGE. ALL RESPONSIBLE PERSONNEL SHOULD LOCATE THE DOOR MOUNTED EQUIPMENT NAMEPLATE AND BE FAMILIAR WITH THE INFORMATION PROVIDED ON THE NAMEPLATE. A TYPICAL EQUIPMENT NAMEPLATE IS SHOWN IN FIGURE 1.

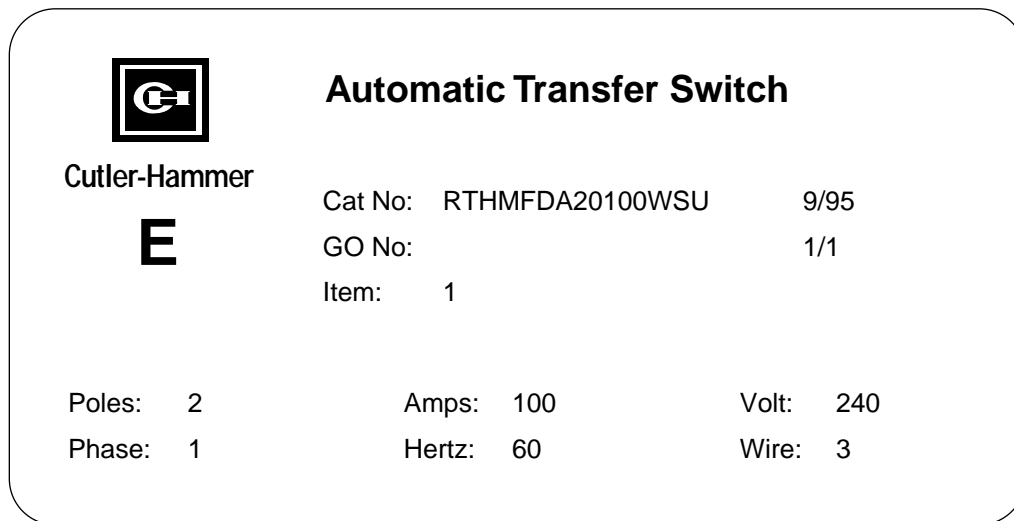

Figure 1 Typical Automatic Transfer Switch Equipment Nameplate

All possible contingencies which may arise during installation, operation or maintenance, and all details and variations of this equipment do no purport to be covered by these instructions. If further information is desired by purchaser regarding his particular installation, operation or maintenance of particular equipment, contact a Cutler-Hammer representative.

TABLE OF CONTENTS

	Page
SECTION 1: INTRODUCTION	
1.1 Preliminary Comments and Safety Precautions.....	1
1.1.1 Warranty and Liability Information.....	1
1.1.2 Safety Precautions.....	1
1.2 General Information.....	1
1.2.1 Design Configuration.....	2
1.3 Transfer Switch Catalog Number Identification.....	2
SECTION 2: RECEIVING, HANDLING AND STORAGE	
2.1 Receiving.....	4
2.2 Handling.....	4
2.3 Storage.....	4
SECTION 3: EQUIPMENT DESCRIPTION	
3.1 Introduction.....	5
3.2 Options.....	5
3.3 Standards.....	5
SECTION 4: INSTALLATION AND WIRING	
4.1 General.....	7
4.2 Mounting Location.....	7
4.3 Mounting Procedure.....	8
4.4 Power Cable Connections.....	9
4.5 Wiring.....	10
4.6 Installation.....	10
4.7 Engine Start Connection.....	10
4.8 Preliminary Checks.....	10
SECTION 5: FUNCTIONAL TESTING	
5.1 Preliminary Checks.....	13
5.2 Energize the Switch.....	13
5.3 Operational Checks.....	13

Page

SECTION 6: TESTING AND PROBLEM SOLVING

6.1 Plant Exerciser Timer14
6.1.1 Timer Programming.....14

SECTION 7: MAINTENANCE

7.1 Introduction.....15
7.2 Procedures.....15

LIST OF FIGURES

Figure	Title	Page
1-1	Typical Load Transfer Switch (circuit breaker type) Schematic.....	1
1-2	Typical Residential Automatic Transfer Switch.....	3
4-1	Dimensions and Plan View of Residential Automatic Transfer Switch (30 -100A)	7
4-2	Dimensions and Plan View of Residential Automatic Transfer Switch (150 -200A)	7
4-3	Cover Removal	8
4-4	Deadfront Removal	9
4-5	Cable Connections	9
4-6	Typical installation of a residential or light duty automatic transfer switch	11
4-7	Typical installation of a residential or light duty automatic transfer switch	11
4-8	Diagram of Typical Installation (Critical Loads Only)	12
4-9	Diagram of Typical Installation (All Household Loads)	12
7-1	Wiring Diagram for Residential Automatic Transfer Switch	16

LIST OF TABLES

Table	Title	Page
1.1	Transfer Switch Catalog Number Explanation.....	2
4.1	Wire Size for Automatic Transfer Switch	9
7.1	Periodic Maintenance Procedures.....	17

SECTION 1: INTRODUCTION

1.1 PRELIMINARY COMMENTS AND SAFETY PRECAUTIONS

This technical document is intended to cover most aspects associated with the installation, application, operation and maintenance of the Residential Automatic Transfer Switch. It is provided as a guide for authorized and qualified personnel only. Please refer to the specific WARNING and CAUTION in Section 1.1.2 before proceeding. If further information is required by the purchaser regarding a particular installation, application or maintenance activity, a Cutler-Hammer representative should be contacted.

1.1.1 WARRANTY AND LIABILITY INFORMATION

No warranties, expressed or implied, including warranties of fitness for a particular purpose of merchantability, or warranties arising from course of dealing or usage of trade, are made regarding the information, recommendations and descriptions contained herein. In no event will Cutler-Hammer be responsible to the purchaser or user in contract, in tort (including negligence), strict liability or otherwise for any special, indirect, incidental or consequential damage or loss whatsoever, including but not limited to damage or loss of use of equipment, plant or power system, cost of capital, loss of power, additional expenses in the use of existing power facilities, or claims against the purchaser or user by its customers resulting from the use of the information and descriptions contained herein.

1.1.2 SAFETY PRECAUTIONS

All safety codes, safety standards and/or regulations must be strictly observed in the installation, operation and maintenance of this device.



WARNING

THE WARNINGS AND CAUTIONS INCLUDED AS PART OF THE PROCEDURAL STEPS IN THIS DOCUMENT ARE FOR PERSONNEL SAFETY AND PROTECTION OF EQUIPMENT FROM DAMAGE. AN EXAMPLE OF A TYPICAL WARNING LABEL HEADING IS SHOWN ABOVE TO FAMILIARIZE PERSONNEL WITH THE STYLE OF PRESENTATION. THIS WILL HELP TO INSURE THAT PERSONNEL ARE ALERT TO WARNINGS, WHICH APPEAR THROUGHOUT THE DOCUMENT. IN ADDITION, CAUTIONS ARE ALL UPPER CASE AND BOLDFACE.



CAUTION

READ AND UNDERSTAND THE MATERIAL PRESENTED IN THIS DOCUMENT BEFORE ATTEMPTING INSTALLATION, OPERATION OR APPLICATION OF THE EQUIPMENT. IN ADDITION, ONLY QUALIFIED PERSONS SHOULD BE PERMITTED TO PERFORM ANY WORK ASSOCIATED WITH THE EQUIPMENT. ANY WIRING INSTRUCTIONS PRESENTED IN THIS DOCUMENT MUST BE FOLLOWED PRECISELY. FAILURE TO DO SO COULD CAUSE PERMANENT EQUIPMENT DAMAGE.

1.2 GENERAL INFORMATION

Transfer switches are used to protect critical electrical loads against loss of power. The load's normal power source is backed up by a secondary (emergency) power source. A transfer switch is connected to both the normal and emergency power sources and supplies the load with power from one of these two sources. In the event that power is lost from the normal power source, the transfer switch transfers the load to the secondary (emergency) power source. Transfer can be automatic or manual, depending upon the type of transfer switch equipment being used. Once normal power is restored, the load is automatically or manually transferred back to

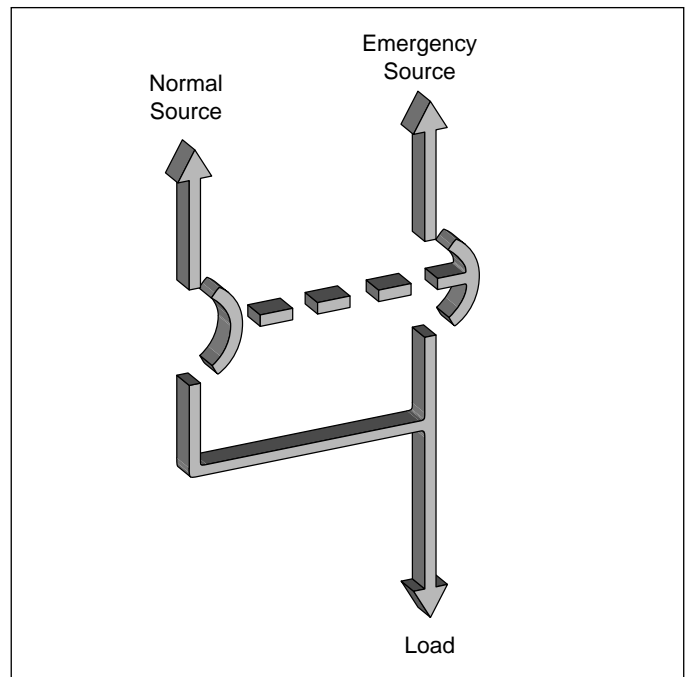

Figure 1-1 Typical Load Transfer Switch (circuit breaker type) Schematic

the normal power source, again depending upon the type of transfer equipment being used (Figure 1-1).

In automatic transfer switch equipment, the switch's intelligence system initiates the transfer when normal power fails or falls below a preset voltage. If the emergency power source is a standby generator, the transfer switch initiates generator starting and transfers to the emergency power source when sufficient generator voltage is available. When normal power is restored, the transfer switch automatically transfers back and initiates engine shutdown. In the event the normal power source fails and the emergency power source does not appear, the automatic transfer switch remains connected to the normal power source until the emergency power source does appear. Conversely, if connected to the emergency power source and the emergency power source fails while the normal power source is still unavailable, the automatic transfer switch remains connected to the emergency power source.

Automatic transfer switches automatically perform the transfer function, and include three basic elements:

- (1) Main contacts to connect and disconnect the load to and from the source of power.
- (2) A mechanism to make the transfer of the main contacts from source to source.
- (3) Intelligence/supervisory circuits to constantly monitor the condition of the power sources and thus provide the intelligence necessary for the switch and related circuit operation.

1.2.1 DESIGN CONFIGURATION

The Cutler-Hammer transfer switch is a rugged, compact design that utilizes molded case switches to transfer essential loads from one power source to another (Figure 1-2). Molded case switches are interlocked to prevent both switches from being closed at the same time.

1.3 TRANSFER SWITCH CATALOG NUMBER IDENTIFICATION

Transfer switch equipment catalog numbers provide a significant amount of relevant information pertaining to a specific piece of equipment. The Catalog Number Identification Table (Table 1.1) provides the required interpretation information. An example is offered to initially simplify the process.

Example: Catalog Number (circled numbers correspond to position headings in Table 1.1)

The catalog number RTHMFDA20100WSU describes an automatic transfer switch with the switching devices mounted horizontally in the enclosure. The intelligence

① to ② ③ ④ ⑤ to ⑥ ⑦ ⑧ ⑨ to ⑫ ⑬ ⑭ ⑮
RT H M FD A 2 0100 W S U

Table 1.1 Transfer Switch Catalog Number Explanation

Positions 1-2		Position 3		Position 4		Positions 5-6		
Basic Device		Switching Device Orientation		Control Panel		Switching Device		
Residential	RT	Horizontal	H	Microprocessor	M	HFD	Cutler-Hammer Series C̄ FD	

Position 7		Position 8	Positions 9-12	Position 13	Position 14	Position 15
Switching Device Arrangement		Number of Poles	Ampere Rating	Voltage/Frequency	Enclosure	Listing
Fixed Mount Molded Case Switches	A	Two 2	30A – 0030 70A – 0070 100A – 0100 150A – 0150 200A – 0200	240VAC/60Hz W	NEMA 1 S NEMA 3R R	UL Listed U

represented by the control panel is microprocessor logic. The frame is for 100 amp service, and the switch is a 2-pole, fixed mount molded case switch. The continuous current rating of this equipment is 100 amperes and applicable at 240 VAC, 60Hz. The transfer switch equipment is enclosed in a NEMA 1 enclosure and listed for UL applications.

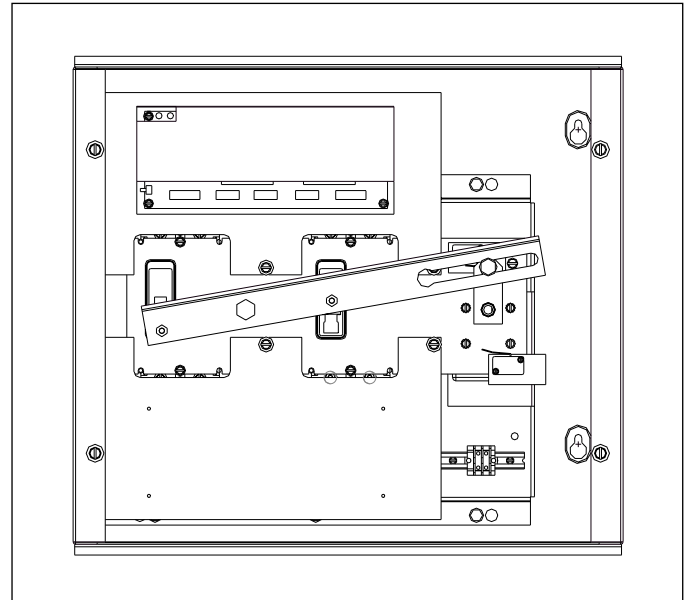

Figure 1-2 Typical Residential Automatic Transfer Switch (30-100A)

SECTION 2: RECEIVING, HANDLING, AND STORAGE

2.1 RECEIVING

Every effort is made to ensure that the transfer switch equipment arrives at its destination undamaged and ready for installation. Packing is designed to protect internal components as well as the enclosure. Care should be exercised, however, to protect the equipment from impact at all times. Do not remove protective packaging until the equipment is ready for installation .

When transfer switch equipment reaches its destination, the customer should inspect the shipping container for any obvious signs of rough handling and/ or external damage that occurred during transportation. Record any external and internal damage for reporting to the transportation carrier and Cutler-Hammer, once a thorough inspection is complete. All claims should be as specific as possible and include Shop Order and General Order numbers.

A shipping label affixed to the shipping container includes a variety of equipment and customer information, such as General Order number and Customer Number. Make certain that this information matches other shipping paper information.

Each transfer switch enclosure is packaged in its own box. Heavy duty cardboard sides surround the enclosure and are further supported with reinforced cardboard corner posts. A heavy duty cardboard lid covers the entire opening. Do not discard the packing material until the equipment is ready for installation.

Once the top packaging is removed from the shipment, the enclosure door can be opened. A plastic bag of documents will be found in the enclosure, usually attached to the inside of the door. Important documents, such as test reports, wiring diagrams, appropriate instruction leaflets and a warranty registration card, are enclosed within the bag and should be filed in a safe place.

2.2 HANDLING

As previously mentioned, transfer switch equipment is packaged in its own box. Protect the equipment from impact at all times and do not double stack. Once the equipment is in the installation location and ready to be installed, packaging material can be removed. Refer to Section 4 of this manual for specific installation instructions.

2.3 STORAGE

Although well packaged, this equipment is not suitable for storage outdoors. The equipment warranty will not be applicable if there is evidence of outdoor storage. If the equipment is to be stored indoors for any period of time, it should be stored with its protective packaging material in place. Protect the equipment at all times from excessive moisture, construction dirt, corrosive conditions, and other contaminants. It is strongly suggested that the package-protected equipment be stored in a climate-controlled environment of -20°C to 65°C with a relative humidity of 80 percent or less. Do not under any circumstance, stack other equipment on top of a transfer switch equipment enclosure, whether packaged or not.

SECTION 3: EQUIPMENT DESCRIPTION

3.1 INTRODUCTION

The Cutler-Hammer Residential Automatic Transfer Switch is assembled and tested at the factory. It is designed to be used in conjunction with standby power distribution equipment to provide an alternate source of power to critical circuits in the event that a primary power source is interrupted.

This switch monitors both normal and standby power sources and automatically transfers critical load circuits between the two sources depending upon which source is available. The normal source is preferred and will remain connected to the switch if it is available.

3.2 OPTIONS

The following section describes the standard features in the RTHM Transfer Switch. The time delays are not adjustable.

1. *Time Delay Normal to Emergency (TDNE)*

This feature delays the transfer from the normal power source to the emergency power source in order to override momentary normal power source outages and/or fluctuations. Timing begins when the emergency power source becomes available. It does not affect initiation of the engine start circuit. Should the normal power source fail, the engine start contact will close and, if connected to an engine generator, will initiate an engine start-up in 10 seconds. The TDNE timer is set for three seconds.

2. *Time Delay on Engine Starting (TDES)*

This feature is used only where the emergency power source is an engine generator. It delays initiation of the engine start circuit in order to override momentary normal power source outages and/or fluctuations. It does not affect the ability of the transfer switch to transfer from the normal power source to the emergency power source. The TDES timer is set for 10 seconds.

3. *Time Delay Emergency to Normal (TDEN)*

This feature delays transfer from the emergency power source to the normal power source to allow the normal power source to stabilize before the transfer is initiated. Timing begins when the normal source becomes available. If the emergency power source fails during timing, the time delay is overridden and an immediate transfer to the normal power source will occur. The TDEN timer is set for 10 seconds.

4. *Time Delay Engine Cool-Off*

This feature allows the engine generator to run after the transfer switch returns to the normal power source without load. The TDEC timer is set for 5 minutes.

5D. *Undervoltage Sensing for Emergency Source*

This feature enables the logic to constantly monitor the emergency power source. The logic prevents transfer from the normal power source to the emergency source until the emergency power source has reached an acceptable operating voltage. Drop-out is set at 70% of nominal voltage and pick-up is set at 80% of nominal voltage.

23. *Plant Exerciser*

This feature is a 7-day timer and provides automatic testing of the emergency source once each week, 15 minutes no load.

26. *Undervoltage Sensing for Normal Source*

This feature enables the logic to constantly monitor the normal power source. The logic prevents transfer from the emergency power source to the normal source until the normal power source has reached an acceptable operating voltage. Drop-out is set at 70% of nominal

3.3 STANDARDS

Cutler-Hammer transfer switch equipment enclosed in a NEMA 1 enclosure is listed for application by UL and UL-C. In addition, Cutler-Hammer automatic transfer switches are listed in File E38116 by Underwriters Laboratories, Inc. under Standard UL 1008. This standard covers requirements for automatic transfer switches intended for use in ordinary locations to provide lighting and power as follows:

- a. In emergency systems, in accordance with articles 517 and 700 in the National Electrical Code, ANSI/NFPA 70 and the National Fire Protection Association No. 76A and/or
- b. In standby systems, in accordance with article 702 of the National Electrical Code and/or
- c. In legally required standby systems in accordance with article 701 of the National Electrical Code.

Cutler-Hammer automatic transfer switches are available to meet NFPA110 for emergency and standby power systems, and NFPA99 for health care facilities when ordered with the appropriate options.

Since Cutler-Hammer automatic transfer switches use specially designed molded case switches as the main power switching contacts, these devices must also be listed under the additional UL Standard 1087. Underwriters laboratories uses two basic types of listing programs — label service and re-examination.

UL1087 employ a label service listing program which requires an extensive follow-up testing program for listed devices. Standard UL1008 for automatic transfer switches lists devices under the reexamination program which only requires a continual physical reexamination of the components used in the product to ensure consistency with the originally submitted device. Follow-up testing is not required by UL1008.

Representative production samples of molded case switches and molded case circuit breakers used in Cutler-Hammer automatic transfer switches are subjected to a complete test program identical to the originally submitted devices on an ongoing periodic basis per UL1087. The frequency of such a re-submittal can be as often as every quarter for a low ampere device. Any failure during one of these periodic re-submittals could result in a loss of the valued UL listing mark.

SECTION 4: INSTALLATION AND WIRING

4.1 GENERAL

Transfer switches are factory wired and tested. Installation requires solidly mounting the enclosed unit and connecting power cables and auxiliary pilot circuits. Physical mounting procedures and power cable connections are covered in this section. Once a transfer switch is properly installed and wired, it should be mechanically and electrically checked for proper installation and operation. The procedures for these initial mechanical and electrical checks are outlined in Section 5 of this instruction manual.

4.2 MOUNTING LOCATION

Choose a location that offers a flat, rigid mounting surface capable of supporting the weight of the enclosed transfer switch equipment (Figure 4-1, 30-100A or Figure 4-2, 150-200A). Avoid locations that are moist, hot, or dusty, however, there are enclosure designs available for special environments. If there are any doubts as to location suitability, discuss it with your Cutler-Hammer representative.

Check to make certain that there are no pipes, wires, or other mounting hazards in the immediate mounting area that could create a problem.

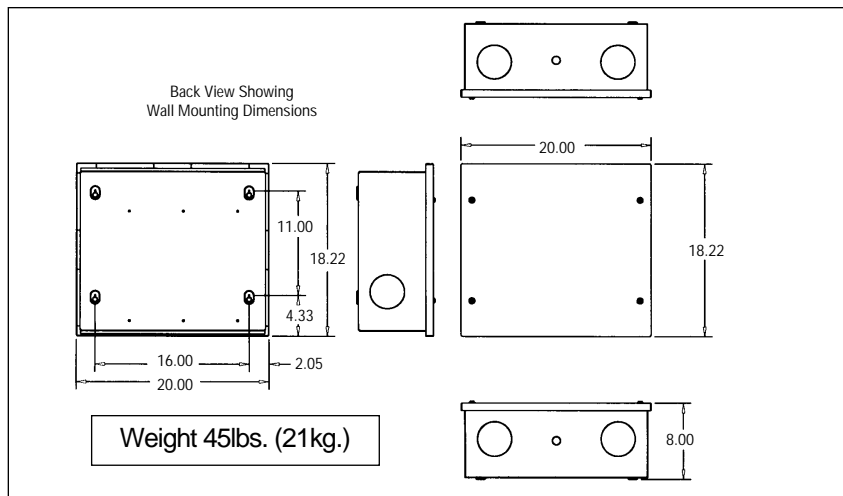

Figure 4-1 Dimensions and Plan View of Residential Automatic Transfer Switch (in) (30-100A)

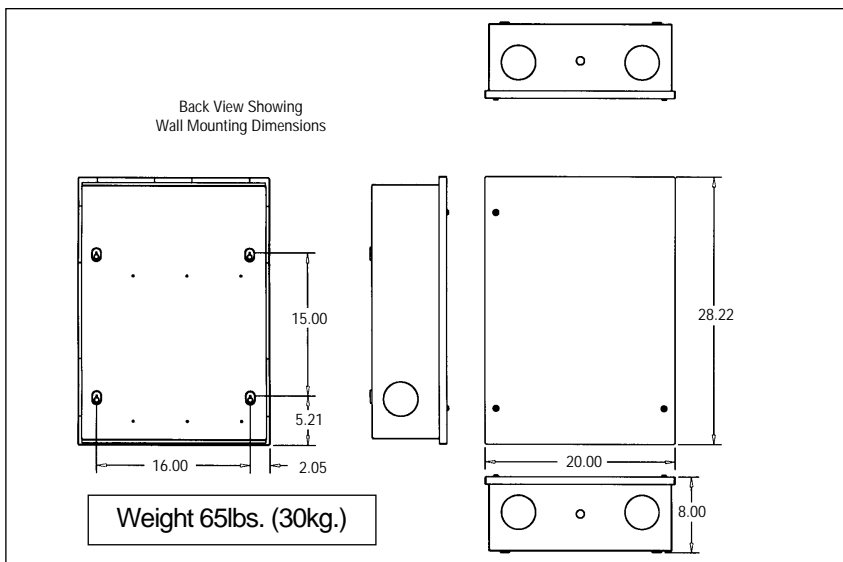

Figure 4-2 Dimensions and Plan View of Residential Automatic Transfer Switch (in) (150-200A)

Carefully remove all packing material from the transfer switch at the mounting location. Do not discard the Top Cardboard Pad. It is used as a template for locating the mounting holes. Even though an equipment inspection was made when the equipment was received, make another careful inspection of the enclosure and the enclosed transfer switch as packing material is removed and the enclosure readied for mounting. Be especially alert for distorted metal, loose wires or damaged components.

4.3 MOUNTING PROCEDURE



CAUTION

EXTREME CARE SHOULD BE TAKEN TO PROTECT THE TRANSFER SWITCH FROM DRILL CHIPS, FILINGS AND OTHER CONTAMINANTS WHEN MAKING THE CABLE ENTRY HOLES AND MOUNTING THE ENCLOSURE TO PREVENT COMPONENT DAMAGE OR A FUTURE MALFUNCTION .

NOTICE

The installation must comply fully with all applicable codes, standards and regulations.

With the enclosed transfer switch equipment unpacked and ready for mounting, proceed with these steps:

- Step 1:** Remove the 4 cover screws and place the cover in a safe place (Figure 4-3).
- Step 2:** Before removing the 4 screws that hold the top Dead Front cover in place, disconnect the 5 white plugs on the logic board. Care should be taken when it is placed aside. Remove the 4 screws from the bottom Dead Front and place it in a safe place (Figure 4-4).
- Step 3:** Depending upon customer preference and Transfer Switch location, the knockouts may be used or additional holes may be drilled for cable entry and control wiring.

NOTICE

For control wiring (Generator start wiring), these wires must be isolated from both power source cables.

Step 4: Mount the switch to a rigid structure as close to the electrical loads as possible. Use the card board template provided to mark the mounting pattern, and start the mounting hardware several turns into the mounting structure. Lift the switch over the embossed teardrop mounting holes and secure the mounting screws.

Step 5: Connect cables as follows (Figure 4-5):

- NORMAL (utility) power cables to terminals N1, N2.
- EMERGENCY (generator) power cables to E1, E2.
- Customer load cables to T1, T2.
- NEUTRAL cable to Neutral terminal.
- GROUND wire to green 1/4-20 bolt.

Step 6: Generator start terminals are red and numbered 51, 52. They are located in the lower right hand corner of the power panel, and used when the generator has an automatic start feature.

Step 7: Tighten all cables and wiring to the specifications on the labeling within the switch.

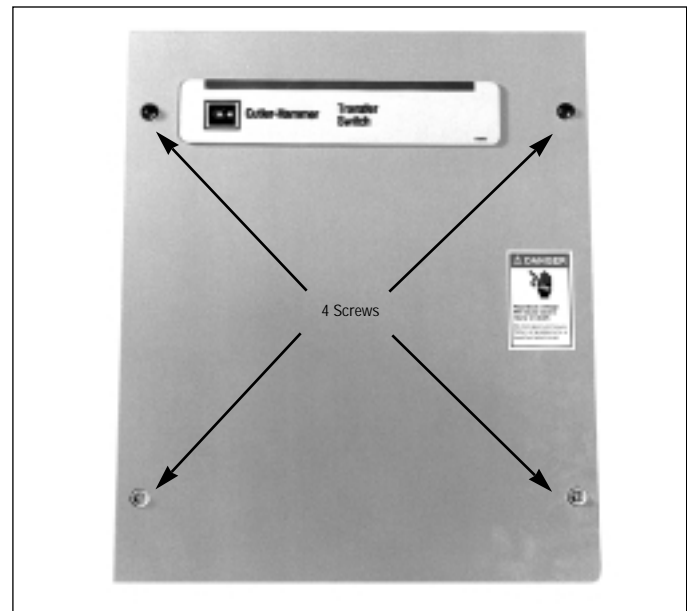

Figure 4-3 Cover Removal

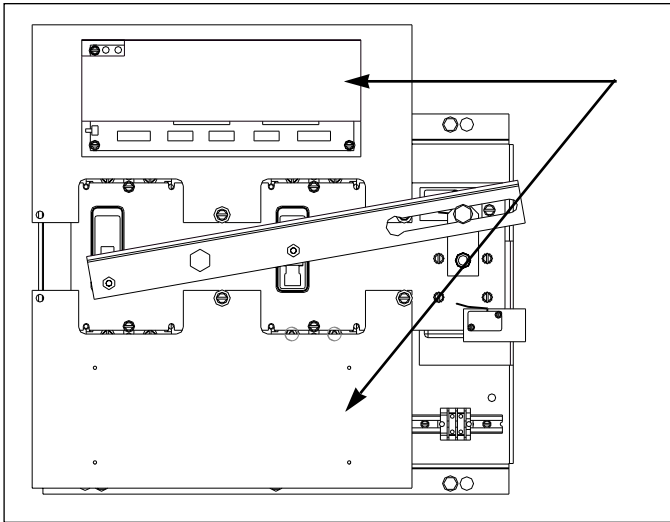

Figure 4-4 Deadfront Removal

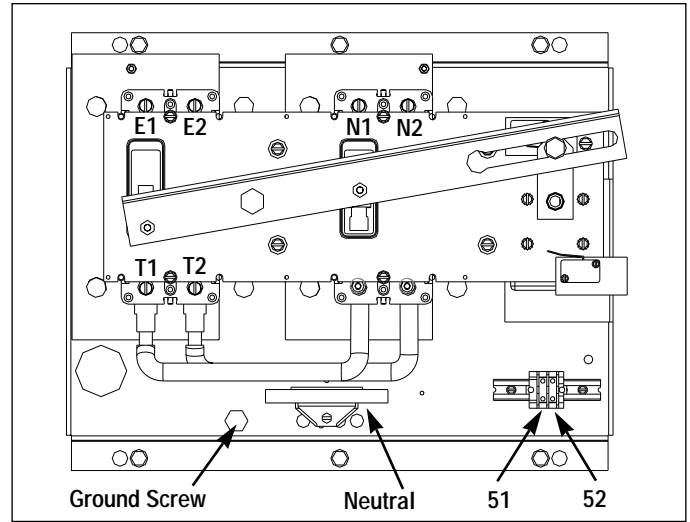

Figure 4-5 Cable Connections

4.4 POWER CABLE CONNECTION



WARNING

POWER CONDUCTORS MAY HAVE VOLTAGE PRESENT THAT CAN CAUSE SEVERE PERSONAL INJURY OR DEATH. DE-ENERGIZE ALL POWER OR CONTROL CIRCUIT CONDUCTORS TO BE CONNECTED TO THE TRANSFER SWITCH EQUIPMENT BEFORE BEGINNING TO WORK WITH THE CONDUCTORS AND/OR TERMINATING THEM TO THE EQUIPMENT.



CAUTION

USE CABLE LUGS, NOT DESIGNED FOR THE TRANSFER SWITCH MAY CAUSE HEATING PROBLEMS. BREAKER LUGS ONLY MOUNT TO THE BREAKER, WHILE TRANSFER SWITCH LUGS MOUNT TO BOTH THE BREAKER AND THE BUSBAR BEHIND THE BREAKER. FOR INSTALLATION INSTRUCTIONS, REFER TO THE INSTRUCTION LEAFLET SUPPLIED FOR THE SPECIFIC LUGS.

Table 4.1 Wire Size for Automatic Transfer Switch

Transfer Switch Amp Rating	Wire Size Range	Number of Cables per Phase
30 - 150	#14 - 3/0	1
200	#6-300MCM	1



CAUTION

TO HELP PREVENT COMPONENT DAMAGE OR FUTURE MALFUNCTIONS, USE EXTREME CARE TO KEEP CONTAMINANTS OUT OF THE TRANSFER SWITCH EQUIPMENT WHEN MAKING POWER CABLE CONNECTIONS.

Test all power cables prior to connection to the unit to ensure that conductors or cable insulation has not been damaged while being pulled into position.

Power cables are to be connected to solderless screw type lugs located on the transfer switch switching devices. Verify that the lugs supplied will accommodate the power cables being used. Also verify that the cables comply with local electrical codes. Standard transfer switch equipment, as supplied from the factory, will accommodate the wire sizes shown in Table 4.1.

Carefully strip insulation from the power cables to avoid nicking or ringing of the conductor strands. Prepare the stripped conductor termination end by cleaning it with a wire brush. If aluminum conductors are used, apply an appropriate joint compound to the clean conductor surface area.

**CAUTION**

IMPROPER POWER CABLE CONNECTIONS CAN CAUSE EXCESSIVE HEAT AND SUBSEQUENT EQUIPMENT FAILURE.

Tighten cable lugs to the torque identified on the label affixed to the unit immediately adjacent to the lugs.

4.5 WIRING**WARNING**

POWER CONDUCTORS AND CONTROL WIRING MAY HAVE VOLTAGE PRESENT THAT CAN CAUSE SEVERE PERSONAL INJURY OR DEATH. DE-ENERGIZE ALL POWER OR CONTROL CIRCUIT CONDUCTORS BEFORE BEGINNING TO PERFORM ANY WIRING ACTIVITY TO OR WITHIN THE TRANSFER SWITCH EQUIPMENT.

**CAUTION**

CHECK THE TRANSFER SWITCH EQUIPMENT NAMEPLATE FOR RATED VOLTAGE. IT SHOULD BE THE SAME AS THE NORMAL AND EMERGENCY LINE VOLTAGES. OPERATING THE EQUIPMENT ON IMPROPER VOLTAGE CAN CAUSE EQUIPMENT DAMAGE.

4.6 INSTALLATION

In a typical installation for critical loads (Figure 4-6), the automatic transfer switch (ATS) (1) and the generator (2) are connected to the residential power supply. The ATS (1) and emergency distribution panel (3) receive normal power from a dedicated breaker in the utility service panel (4). The ATS and emergency panel receive emergency power from the generator (2). Power from the utility feeds the utility panel.

When normal power fails, the ATS will sense the failure, start the generator, and switch all loads to the emergency panel. All emergency loads will receive power from the

generator. A line breaker is required between the emergency source (generator) and the transfer switch (Figure 4-8). When normal power returns, the ATS will switch all power back to the utility and shut down the generator.

In addition, another typical installation for household loads can be considered (Figure 4-7). Refer to Figure 4-9 for a household loads connection diagram.

4.7 ENGINE START CONNECTION

The engine control contact connections are located on the lower right of the intelligence portion of the ATS. NOTE: Prior to making the engine start connection to the switch, set the engine generator controls selector switch in the OFF position to prevent an unwanted engine start. Connect the engine start wires to the red terminal blocks marked 51 and 52. A contact closes between these terminal blocks when an engine start signal is provided by the ATS logic. The wiring diagram (Figure 7-1) provides additional engine start connection information.

4.8 PRELIMINARY CHECKS

After the ATS enclosure is installed and power cables are connected to the equipment, thoroughly inspect the unit to ensure that no tools were left inside and that the cabinet is free of debris. If necessary, use a vacuum cleaner to remove any and all construction or installation debris from the equipment.

Read and understand all labels on the equipment. Review and understand the wiring diagrams supplied with the equipment. Note any optional accessories that may have been furnished with this unit and review their operation.

Verify that the phase-to-phase line voltages of both the normal and emergency power sources are the same and that they match rated voltage as indicated on the ATS ratings label.

**CAUTION**

SEVERE EQUIPMENT DAMAGE CAN RESULT IF UNIT IS NOT APPLIED AT PROPER VOLTAGE. DO NOT ENERGIZE EQUIPMENT IF SUPPLY VOLTAGES DO NOT MATCH EQUIPMENT RATINGS LABEL. CONTACT THE FACTORY FOR INSTRUCTIONS TO MODIFY THE VOLTAGE RATING IN THE FIELD.

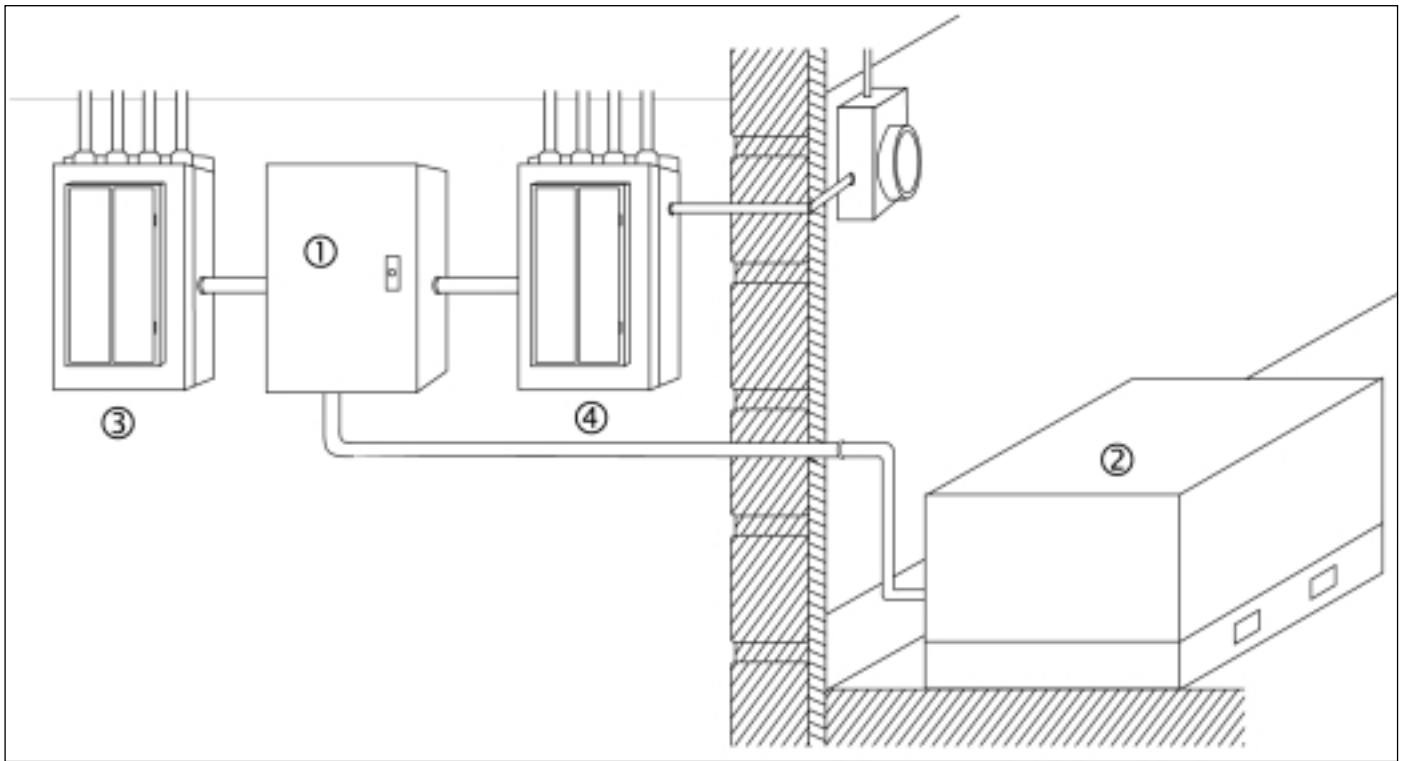

Figure 4-6 Typical installation of a residential or light duty automatic transfer switch. The switch (1) and generator (2) are connected to the power supply. The automatic transfer switch is located between the emergency distribution (3) and the utility panel (4).

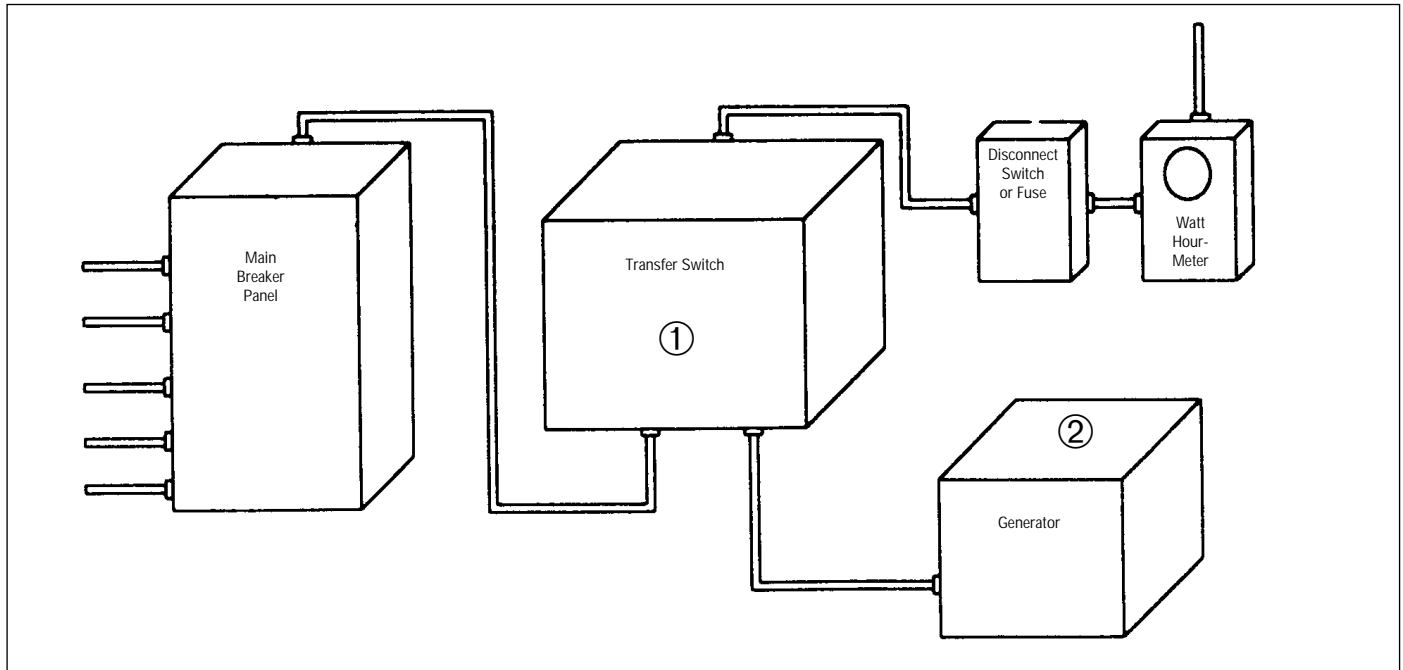

Figure 4-7 Typical installation of a residential or light duty automatic transfer switch. The switch (1) and generator (2) are connected to the power supply. The automatic transfer switch is located between the utility and the household loads.

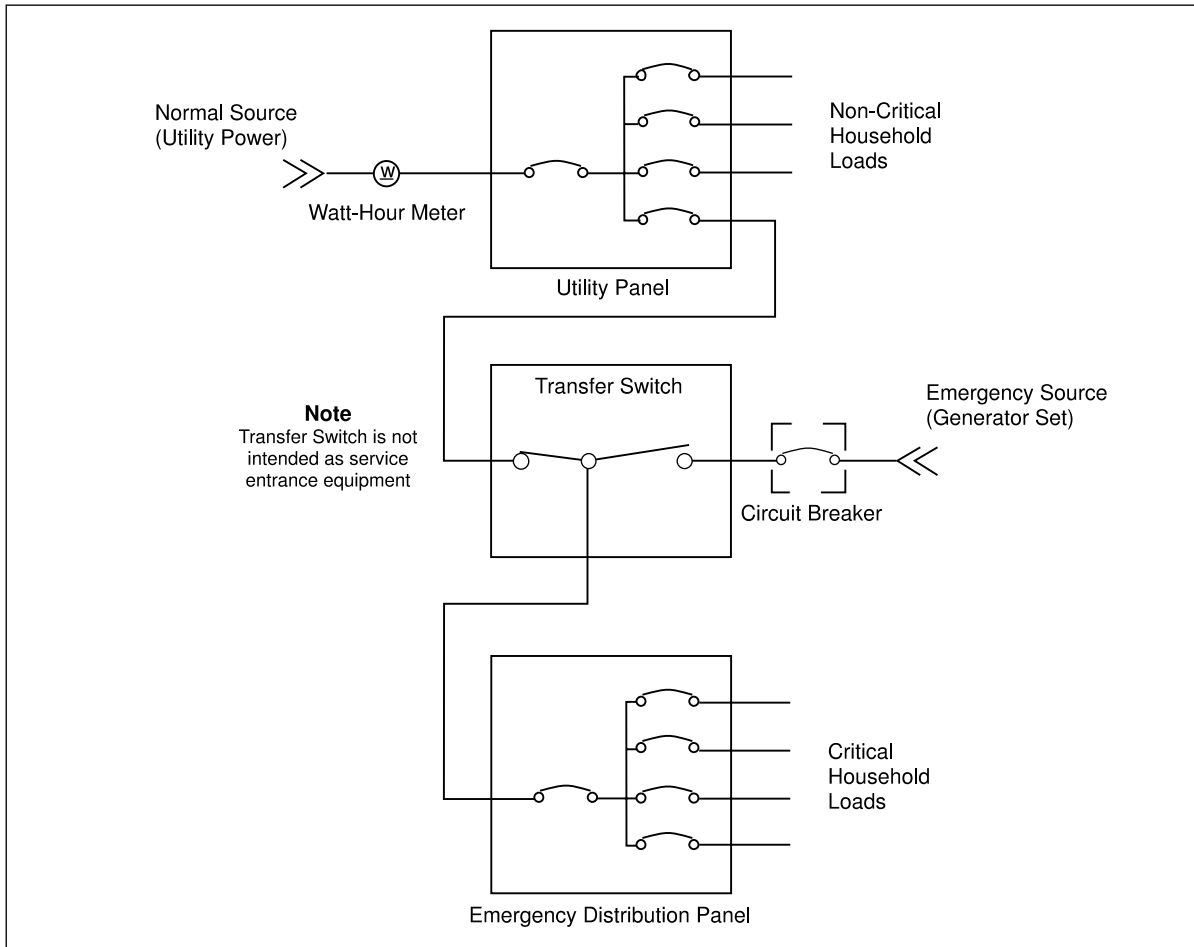

Figure 4-8 Diagram of Typical Installation (Critical Loads Only)

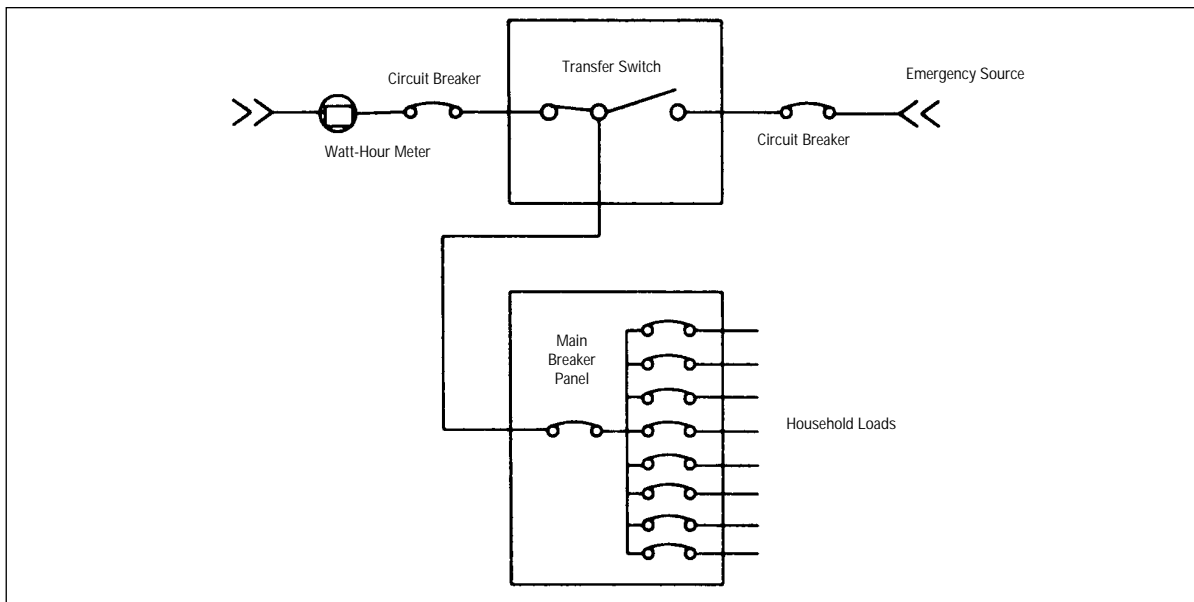

Figure 4-9 Diagram of Typical Installation (All Household Loads)

SECTION 5: FUNCTIONAL TESTING



WARNING

YOU ARE READY TO ENERGIZE THE EQUIPMENT. VOLTAGES WITHIN THE ENCLOSURE ARE CAPABLE OF CAUSING SEVERE PERSONAL INJURY OR DEATH.

USE EXTREME CAUTION TO AVOID CONTACT WITH ENERGIZED EQUIPMENT.

5.1 PRELIMINARY CHECKS

Step 1: Check all loads connected the ATS to ensure that they are ready to be energized.

5.2 ENERGIZE THE SWITCH

Step 1: Close the upstream normal source breaker or switch to connect the ATS to the normal source voltage.

Step 2: If the ATS unit is not already in the NORMAL position, the motorized transfer mechanism will engage and automatically switch to the NORMAL position.

Step 3: Using a voltmeter, measure line-to-line and line-to-neutral voltages across the normal line terminals to ensure normal voltage is correct.



WARNING

CONTACT WITH ENERGIZED COMPONENTS WILL CAUSE ELECTRICAL SHOCK CAPABLE OF PRODUCING SEVERE PERSONAL INJURY OR DEATH. USE EXTREME CAUTION TO AVOID CONTACT WITH ENERGIZED COMPONENTS WHEN USING A METER FOR VOLTAGE CHECKS.

Step 4: Position the engine control selector switch located on the standby engine generator to the AUTOSTART position. (It may also be labeled REMOTE START.)

Step 5: Close the upstream emergency source breaker or switch to connect the ATS to the emergency supply source.

5.3 OPERATIONAL CHECKS

Step 1: Open the upstream normal breaker originally closed in Step 2 of Section 5.2.

NOTICE

This will simulate an interruption of the normal power source.

Step 2: After a brief time delay of 10 seconds, the standby engine generator will start.

Step 3: The ATS Time Delay Normal to Emergency (TDNE) will begin to time after the engine begins to run. After time out, the motorized transfer mechanism will engage and automatically switch from the NORMAL to EMERGENCY position.

Step 4: Using a voltmeter, measure line-to-line and line-to-neutral voltages across the emergency line terminals to ensure that the emergency voltage is correct. If necessary, make adjustments to the voltage regulator on the generator according to the manufacturer's recommendations to correct any voltage deviations. The ATS will only respond to correct voltage from the emergency source.

Step 5: Close the normal breaker described in Step 1.

Step 6: The ATS Time Delay Emergency to Normal (TDEN) timer will begin timing, and the motorized transfer mechanism will engage and automatically switch from the EMERGENCY to NORMAL position and the generator will shut down.

SECTION 6: ADJUSTMENTS

6.1 PLANT EXERCISER TIMER

Option 23, described in Section 3.5, is a plant exerciser. The plant exerciser is a once every 7-day timer switch used to exercise the engine driven generator.

6.1.1 TIMER PROGRAMMING

Depress the PE Switch located on the end of the printed circuit board for 2 seconds and release. Both Normal and Emergency LEDs will flash twice indicating the plant exerciser is now programmed correctly. The transfer switch will initiate a test now and every seven days from this time forward. If for some reason both power sources are unavailable for longer than 20 seconds, the plant exerciser will have to be reprogrammed when either power source becomes available. To cancel the plant exerciser, depress the PE Switch for 4 seconds and release. Both Normal and Emergency LEDs will flash 4 times to indicate the plant exerciser is now disabled. After the current exercise is complete the Transfer Switch will transfer back to Normal. The plant exerciser will now have to be reprogrammed in order to exercise the generator.

SECTION 7: MAINTENANCE

7.1 INTRODUCTION



WARNING

HIGH VOLTAGES ARE PRESENT IN AND AROUND TRANSFER SWITCH EQUIPMENT. BEFORE INSPECTING OR MAINTAINING THIS EQUIPMENT, DISCONNECT LINE POWER FROM THE EQUIPMENT BEING SERVICED BY OPENING AND LOCKING OUT, IF POSSIBLE, THE NEXT HIGHEST DISCONNECT DEVICE. FAILURE TO FOLLOW THIS PROCEDURE COULD CAUSE PERSONAL INJURY AND/OR DEATH.

In general, transfer switch equipment is designed to be relatively maintenance free under normal usage. However, because of the variability of application conditions and the importance placed on dependable operation by this type of equipment, inspection and mainte-

nance checks should be made on a regularly scheduled basis. Since equipment maintenance will consist mainly of keeping the equipment clean, the frequency of maintenance will depend, to a large extent, on the cleanliness of the surroundings. If a significant amount of dust or foreign matter is present, a more frequent maintenance schedule should be followed.

It is suggested that visual inspections of the equipment be made on a regular basis, not just during regularly scheduled periods. Always be alert for an accumulation of dirt in and around the structure, loose parts and/or hardware, cracks and/or discoloration to insulation, and damaged or discolored components.

Figure 7-1 is the wiring diagram for the residential automatic transfer switch. Only qualified and experienced personnel should attempt any diagnostic work using this diagram.

7.2 PROCEDURES

A suggested maintenance procedure to follow is outlined in Table 7.1.

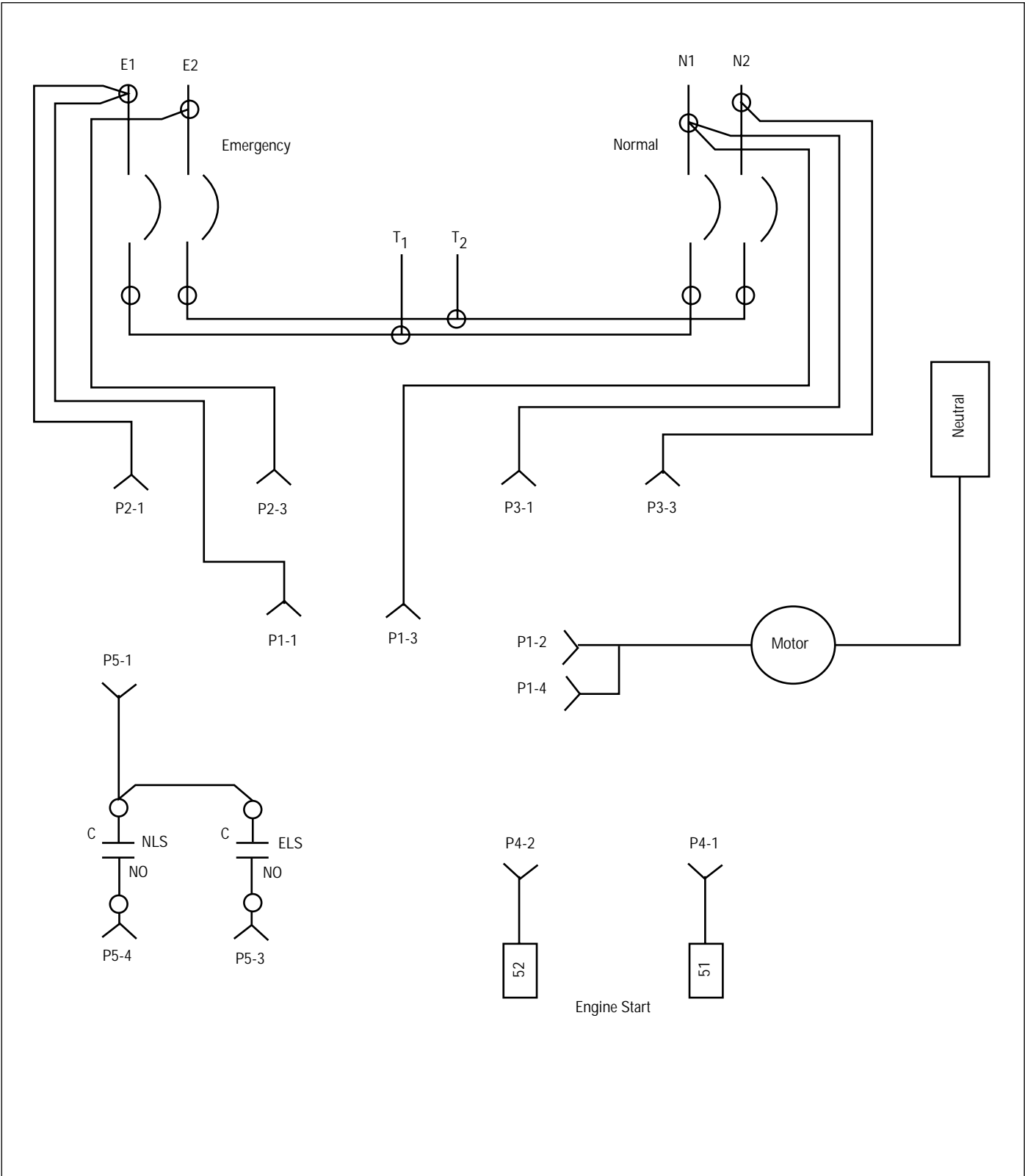

Figure 7-1 Wiring Diagram for Residential Automatic Transfer Switch

Table 7.1 Periodic Maintenance Procedures

Step	Action
a. Make transfer switch equipment safe for inspection and/or maintenance.	Disconnect line power from equipment being serviced by opening next highest disconnect device. Make certain that any accessory control power is switched off.
b. Inspect structure area for safety hazards or potential maintenance problems.	<p>Inspect area, especially where molded case switching devices are installed, for any safety hazards, including personnel safety and fire hazards. Exposure to certain chemical vapors can cause deterioration of electrical connections.</p> <p>Inspect for accumulated dirt, loose hardware or physical damage.</p> <p>Examine primary insulation for evidence of cracking or overheating. Overheating will show as discoloration, melting, or blistering of conductor insulation, or as pitting or melting of conductor surfaces due to arcing.</p> <p>Inspect secondary control connections for damage, and control wiring for insulation integrity.</p>
c. Inspect molded case switching devices for dust, dirt, soot, grease, moisture or corrosion.	Remove dust, dirt, soot, grease, moisture and corrosion contamination from the surface of the switching device using a dry soft lint-free cloth, dry soft bristle brush and vacuum cleaner. Do not blow debris into circuit breaker or nearby breaker structure. If contamination is found, look for the source and fix the problem.
d. Check for material integrity, uneven wear, discoloration or loose hardware.	Severe material cracking will require replacement and loose hardware will need to be tightened.
e. Check terminals and connectors for looseness or signs of overheating.	<p>Overheating will show as discoloration, melting, or blistering of conductor insulation.</p> <p>Connections that do not have signs of looseness or overheating should not be disturbed.</p>
f. Exercise the molded case switching devices if they are not often exercised while in operation. This will permit wiping action by the contacts.	If a switching device is used for frequent switching during normal operation, this step can be disregarded.
g. Return transfer switch equipment to service.	Make certain all barriers are in place and doors closed. Re-apply secondary and primary power.

This instruction booklet is published solely for information purposes and should not be considered all inclusive. If further information is required, you should consult Cutler-Hammer.

Sale of product shown in this literature is subject to terms and conditions outlined in appropriate Cutler-Hammer selling policies or other contractual agreement between the parties. This literature is not intended to and does not enlarge or add to any such contract. The sole source governing the rights and remedies of any purchaser of this equipment is the contract between the purchaser and Cutler-Hammer.

NO WARRANTIES, EXPRESSED OR IMPLIED, INCLUDING WARRANTIES OF FITNESS FOR A PARTICULAR PURPOSE OR MERCHANTABILITY, OR WARRANTIES ARISING FROM COURSE OF DEALING OR USAGE OF TRADE, ARE MADE REGARDING THE INFORMATION, RECOMMENDATIONS AND DESCRIPTIONS CONTAINED HEREIN. In no event will Cutler-Hammer be responsible to the purchaser or user in contract, in tort (including negligence), strict liability or otherwise for any special, indirect, incidental or consequential damage or loss whatsoever, including but not limited to damage or loss of use of equipment, plant or power system, cost of capital, loss of power, additional expenses in the use of existing power facilities, or claims against the purchaser or user by its customers resulting from the use of the information, recommendations and description contained herein.

Cutler-Hammer

Pittsburgh, Pennsylvania U.S.A.

Effective 9/99 (ISI)
Style 5724B30H03
Printed in U.S.A.

EAT•N