



Instructions for Cutler-Hammer Transfer Switch Equipment (30 - 1000 Amperes)





WARNING

READ AND UNDERSTAND THE INSTRUCTIONS CONTAINED HEREINAFTER BEFORE ATTEMPTING TO UNPACK, ASSEMBLE, OPERATE OR MAINTAIN THIS EQUIPMENT.

HAZARDOUS VOLTAGES ARE PRESENT INSIDE TRANSFER SWITCH ENCLOSURES THAT CAN CAUSE DEATH OR SEVERE PERSONAL INJURY. FOLLOW PROPER INSTALLATION, OPERATION AND MAINTENANCE PROCEDURES TO AVOID THESE VOLTAGES.

TRANSFER SWITCH EQUIPMENT COVERED BY THIS INSTRUCTION BOOK IS DESIGNED AND TESTED TO OPERATE WITHIN ITS NAMEPLATE RATINGS. OPERATION OUTSIDE OF THESE RATINGS MAY CAUSE THE EQUIPMENT TO FAIL RESULTING IN DEATH, SERIOUS BODILY INJURY AND/OR PROPERTY DAMAGE. ALL RESPONSIBLE PERSONNEL SHOULD LOCATE THE DOOR MOUNTED EQUIPMENT NAMEPLATE AND BE FAMILIAR WITH THE INFORMATION PROVIDED ON THE NAMEPLATE. A TYPICAL EQUIPMENT NAMEPLATE IS SHOWN IN FIGURE 1.

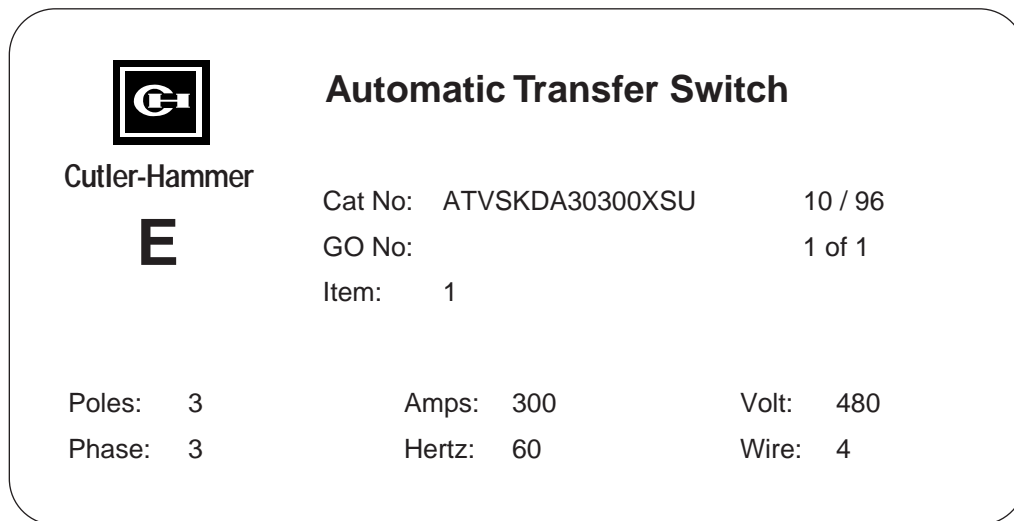

Figure 1 Typical Automatic Transfer Switch Equipment Nameplate

All possible contingencies which may arise during installation, operation or maintenance, and all details and variations of this equipment do no purport to be covered by these instructions. If further information is desired by purchaser regarding his particular installation, operation or maintenance of particular equipment, contact a Cutler-Hammer representative.

TABLE OF CONTENTS

	Page
SECTION 1: INTRODUCTION	
1.1 Preliminary Comments and Safety Precautions.....	1
1.1.1 Warranty and Liability Information.....	1
1.1.2 Safety Precautions.....	1
1.2 General Information.....	1
1.2.1 Transfer Switch Types.....	2
1.2.2 Design Configuration.....	2
1.3 Transfer Switch Catalog Number Identification.....	3
SECTION 2: RECEIVING, HANDLING AND STORAGE	
2.1 Receiving.....	6
2.2 Handling.....	6
2.3 Storage.....	6
SECTION 3: EQUIPMENT DESCRIPTION	
3.1 General.....	7
3.2 Power Panel.....	7
3.2.1 Vertical Design Steel Base Plate.....	8
3.2.2 Main Contacts.....	8
3.2.3 Vertical Design Transfer Mechanism.....	8
3.2.4 Horizontal Design Transfer Mechanism.....	8
3.3 Voltage Selection Panel.....	9
3.4 Logic Panel.....	9
3.5 Options (Non-Logic Panel).....	9
3.6 Enclosure.....	11
3.7 Standards.....	12
SECTION 4: INSTALLATION AND WIRING	
4.1 General.....	13
4.2 Mounting Location.....	13
4.3 Mounting Procedure.....	13
4.4 Vertical Design Load Lug Location.....	15
4.5 Power Cable Connections.....	19
4.6 Wiring.....	20
4.7 Voltage Selection Adjustments.....	20
SECTION 5: OPERATION	
5.1 General.....	22
5.2 Vertical Design Operation.....	22
5.3 Horizontal Design Operation.....	23
5.4 Non-Automatic Operation (Manually Operated).....	24
5.5 Non-Automatic Operation (Electrically Operated).....	24
5.6 Automatic Transfer Switch.....	24

	Page
SECTION 6: TESTING AND PROBLEM SOLVING	
6.1 Testing	26
6.2 Problem Solving	26
6.2.1 Transfer Switch Appears Inoperative	26
SECTION 7: MAINTENANCE	
7.1 Introduction.....	28
7.2 Procedures.....	28

LIST OF FIGURES

Figure	Title	Page
1	Typical Automatic Transfer Switch Equipment Nameplate	iii
1-1	Typical Load Transfer Switch (circuit breaker type) Schematic.....	2
1-2	Vertical Design Automatic Transfer Switch Equipment with Deadfront Cover in Place Over Power Panel (225-1000 Amperes).....	3
1-3	Vertical Design Automatic Transfer Switch Equipment Shown with Deadfront Cover Removed (225-1000 Amperes).....	3
1-4	Horizontal Design Automatic Transfer Switch Equipment (30-150 Amperes)	5
3-1	Typical Vertical Design Power Panel (Unmounted).....	7
3-2	Typical Horizontal Design Power Panel (Mounted)	7
3-3	Molded Case Switches Mounted in Vertical Design (Transfer Mechanism Removed for Clarity).....	8
3-4	Vertical Design Voltage Selection Panel with Voltage Being Selected	9
3-5	Typical Solid State Logic Panel (Door Mounted)	9
3-6	Charger Mounting Dimensions in inches (mm).....	10
3-7	Typical Type 1 Enclosure (Door Closed)	11
4-1	Enclosed Automatic Transfer Switch Dimensions and Approximate Weights	14
4-2	Vertical Design Power Panel Mounting Reference in Inches (mm)	15
4-3	Vertical Design Load Lug Assembly Shown Mounted	16
4-4	Typical (225-1000 Amperes) Vertical Design Transfer Switch Equipment (Door Open and Deadfront Shield Removed).....	17
4-5	Typical (30-150 Amperes) Horizontal Design Transfer Switch Equipment (Door Open).....	18
4-6	Line Voltage Plug and Receptacles (shown with covers removed) for Horizontal Design	20
5-1	Transfer Switch Manual Operating Handle in Use on Vertical Design	22
5-2	Indicator Wheel Shown Mounted in Mechanism with Motor Mounted Under Wheel	22
5-3	Indicator Wheel Indicating Neutral Position on Vertical Design.....	23
5-4	Motor Disconnect Being Unplugged	23
5-5	Electrical Operation Pushbutton and Position Indicating Lights Shown Mounted	24

LIST OF TABLES

Table	Title	Page
1.1	Transfer Switch Catalog Number Explanation.....	4
3.1	Transfer Switch Equipment Enclosures.....	12
4.1	Bolted Bus Connection Torque Requirements	17
4.2	Transfer Switch Equipment Wire Sizes	19
7.1	Periodic Maintenance Procedures.....	29

SECTION 1: INTRODUCTION

1.1 PRELIMINARY COMMENTS AND SAFETY PRECAUTIONS

This technical document is intended to cover most aspects associated with the installation, application, operation and maintenance of transfer switch equipment with ratings from 30 through 1000 amperes, except for the specific logic used to control the equipment. It is provided as a guide for authorized and qualified personnel only. Please refer to the specific WARNING and CAUTION in Section 1.1.2 before proceeding. If further information is required by the purchaser regarding a particular installation, application or maintenance activity, a Cutler-Hammer representative should be contacted. For information associated with the control, refer to the separate instruction book pertaining to the logic package installed in the switch.

1.1.1 WARRANTY AND LIABILITY INFORMATION

No warranties, expressed or implied, including warranties of fitness for a particular purpose of merchantability, or warranties arising from course of dealing or usage of trade, are made regarding the information, recommendations and descriptions contained herein. In no event will Cutler-Hammer be responsible to the purchaser or user in contract, in tort (including negligence), strict liability or otherwise for any special, indirect, incidental or consequential damage or loss whatsoever, including but not limited to damage or loss of use of equipment, plant or power system, cost of capital, loss of power, additional expenses in the use of existing power facilities, or claims against the purchaser or user by its customers resulting from the use of the information and descriptions contained herein.

1.1.2 SAFETY PRECAUTIONS

All safety codes, safety standards and/or regulations must be strictly observed in the installation, operation and maintenance of this device.



WARNING

THE WARNINGS AND CAUTIONS INCLUDED AS PART OF THE PROCEDURAL STEPS IN THIS DOCUMENT ARE FOR PERSONNEL SAFETY AND PROTECTION OF EQUIPMENT FROM DAMAGE. AN EXAMPLE OF A TYPICAL WARNING LABEL HEAD-ING IS SHOWN ABOVE TO FAMILIARIZE PERSON-

NEL WITH THE STYLE OF PRESENTATION. THIS WILL HELP TO INSURE THAT PERSONNEL ARE ALERT TO WARNINGS, WHICH APPEAR THROUGHOUT THE DOCUMENT. IN ADDITION, CAUTIONS ARE ALL UPPER CASE AND BOLDFACE.



CAUTION

COMPLETELY READ AND UNDERSTAND THE MATERIAL PRESENTED IN THIS DOCUMENT BEFORE ATTEMPTING INSTALLATION, OPERATION OR APPLICATION OF THE EQUIPMENT. IN ADDITION, ONLY QUALIFIED PERSONS SHOULD BE PERMITTED TO PERFORM ANY WORK ASSOCIATED WITH THE EQUIPMENT. ANY WIRING INSTRUCTIONS PRESENTED IN THIS DOCUMENT MUST BE FOLLOWED PRECISELY. FAILURE TO DO SO COULD CAUSE PERMANENT EQUIPMENT DAMAGE.

1.2 GENERAL INFORMATION

Transfer switches are used to protect critical electrical loads against loss of power. The load's normal power source is backed up by a secondary (emergency) power source. A transfer switch is connected to both the normal and emergency power sources and supplies the load with power from one of these two sources. In the event that power is lost from the normal power source, the transfer switch transfers the load to the secondary (emergency) power source. Transfer can be automatic or manual, depending upon the type of transfer switch equipment being used. Once normal power is restored, the load is automatically or manually transferred back to the normal power source, again depending upon the type of transfer equipment being used (Figure 1-1).

In automatic transfer switch equipment, the switch's intelligence system initiates the transfer when normal power fails or falls below a preset voltage. If the emergency power source is a standby generator, the transfer switch initiates generator starting and transfers to the emergency power source when sufficient generator voltage is available. When normal power is restored, the transfer switch automatically transfers back and initiates engine shutdown. In the event the normal power source fails and the emergency power source does not appear, the automatic transfer switch remains connected to the normal power source until the emergency power source does appear. Conversely, if connected to the emergency power source and the emergency power source fails while the normal power source is still unavailable, the automatic transfer switch remains connected to the emergency power source.

1.2.1 TRANSFER SWITCH TYPES

Four types of basic transfer switch equipment are available:

Automatic Transfer Switch

Automatic transfer switches automatically perform the transfer function. They consist of three basic elements:

- (1) Main contacts to connect and disconnect the load to and from the source of power.
- (2) Intelligence/supervisory circuits to constantly monitor the condition of the power sources and thus provide the intelligence necessary for the switch and related circuit operation.
- (3) A transfer mechanism to effect the transfer of the main contacts from source to source.

Basic Transfer Switch

The basic transfer switch is designed for use with customer furnished controls. It is similar in design to the automatic version except the intelligence circuit (logic panel) and voltage selection panel are omitted. All automatic sensing devices, relays or solid state devices are the customer's responsibility.

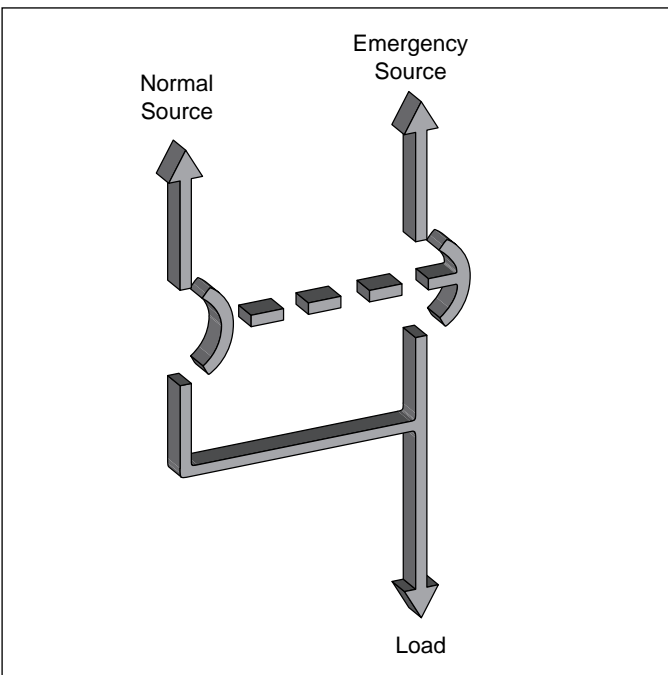

Figure 1-1 Typical Load Transfer Switch (circuit breaker type) Schematic

Non-Automatic Transfer Switch (Manually Operated)

Non-Automatic transfer switches provide the main contacts and the transfer mechanism to effect the transfer of the main contacts from source to source. Transfer of power, however, is accomplished by true hand operation (not power assisted) of the transfer switch. This switch is similar to the basic switch in that an intelligence circuit and a motor driven mechanism are not part of the design.

Non-Automatic Transfer Switch (Electrically Operated)

This transfer switch is similar to the Non-Automatic Transfer Switch (Manually Operated) just described except that an electrical operation feature is added. The switch electrically transfers power when an appropriate pushbutton on the front of the enclosure is pushed. If necessary, the switch can also be operated manually.

1.2.2 DESIGN CONFIGURATION

The Cutler-Hammer transfer switch is a rugged, compact design utilizing molded case switches to effect the transfer of essential loads from one power source to another (Figures 1-2, 1-3 and 1-4). Molded case switches are interlocked to prevent both switches from being closed at the same time. The versatile design, in addition to standard transfer functions, offers an optional integral thermal and short circuit protection in either or both switching devices.

Molded case switches and the associated transfer mechanism are usually mounted vertically in the assembly. The vertical configuration (225-1000 amperes) is accomplished by utilizing a positive, metallic transfer and interlocking system between the molded case switches. A horizontally mounted transfer mechanism is utilized with transfer switches 30 to 150 amperes.

The Cutler-Hammer automatic transfer switch was designed with installation ease and simplified maintenance in mind. Three main panels comprise the automatic transfer switch design:

- Power Panel
- Voltage Selection Panel
- Logic Panel

Each panel is independently mounted with interconnecting wiring terminated in connector plugs to permit individual door or panel removal without disturbing critical connections. Enclosure mounting is simplified by utilizing top and bottom mounting flanges with elongated mounting holes.

For the vertical design, installed power panel positioning bolts, elongated mounting holes and pre-tapped inserts insure proper power panel mounting after initial enclosure installation or when switching from top to bottom entry and vice versa. Refer to Section 4 for mounting and modification details.

1.3 TRANSFER SWITCH CATALOG NUMBER IDENTIFICATION

Transfer switch equipment catalog numbers provide a significant amount of relevant information that pertains to a particular piece of equipment. The Catalog Number Identification Table (Table 1.1) provides the required interpretation information. An example is offered to initially simplify the process.

Example: Catalog Number (*circled numbers correspond to position headings in Table 1.1*) –

① to ② ③ ④ ⑤ to ⑥ ⑦ ⑧ ⑨ to ⑫ ⑬ ⑭ ⑮
AT V S KD A 3 0225 B S U

The catalog number ATVSKDA30225BSU describes an Automatic Transfer Switch with the switching devices mounted vertically in the enclosure. The intelligence represented by the control panel is solid state logic. The Cutler-Hammer Series C Type HKD is used as the switching device and is in the form of a 3-pole molded case switch on each source. The continuous current rating of this equipment is 225 amperes and applicable at 208 VAC, 60Hz. The transfer switch equipment is enclosed in a NEMA 1 enclosure and is both UL and UL-C listed.



Figure 1-2 Vertical Design Automatic Transfer Switch Equipment with Deadfront Cover in Place Over Power Panel (225-1000 Amperes)

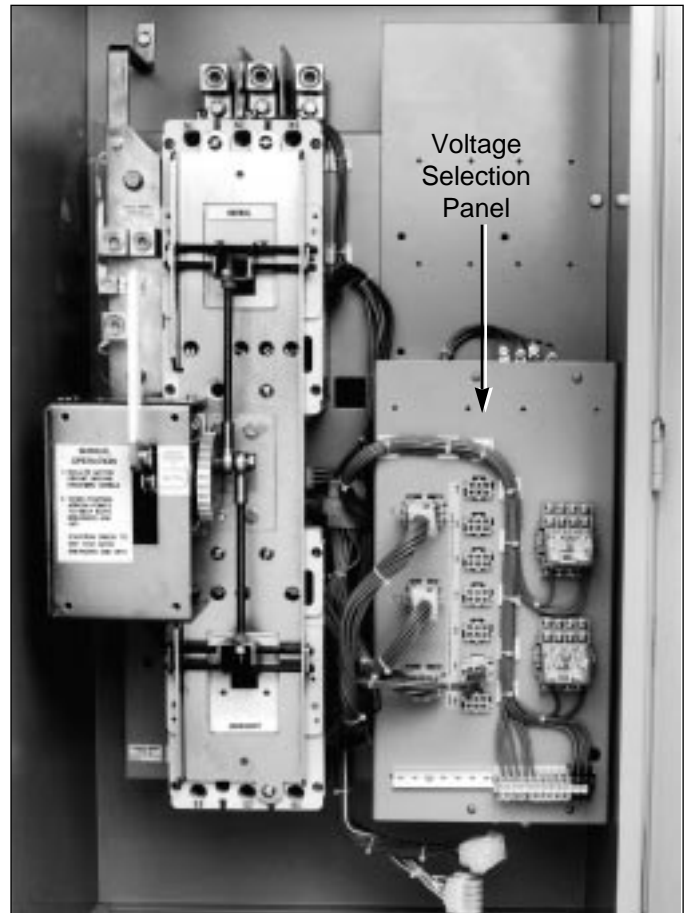

Figure 1-3 Vertical Design Automatic Transfer Switch Equipment Shown with Deadfront Cover Removed (225-1000 Amperes)

Table 1.1 Transfer Switch Catalog Number Explanation^④

Positions 1-2		Position 3		Position 4		Positions 5-6		
Basic Device		Switching Device Orientation		Control Panel		Switching Device		
Automatic Transfer Switch	AT	Vertical	V ^①	IQ Transfer	I	HFD	Cutler-Hammer Series C	FD
		Horizontal	H ^②			HKD		
Non-Automatic Transfer Switch (Electrically Operated)	NT			Microprocessor	M	HLD	Cutler-Hammer Series C	LD
				Solid State Logic	S	MA	Cutler-Hammer	MA
				Not Applicable	X	NB	Cutler-Hammer	NB
Non-Automatic Transfer Switch (Manually Operated)	MT					HND	Cutler-Hammer Series C	ND ^③
Basic Transfer Switch (Power Panel Only)	PP							

Position 7		Position 8		Positions 9-12		Position 13		Position 14		Position 15	
Switching Device Arrangement		Number of Poles		Ampere Rating		Voltage/Frequency		Enclosure		Listing	
Fixed Mount Molded Case Switches Both Power Sources	A	Two	2	30A – 0030	120VAC/60Hz	A	No Enclosure	K	UL Listed	U	
				70A – 0070	208VAC/60Hz	B	Type 1	S			
Fixed Mount Molded Case Breakers Both Power Sources	B	Three	3	100A – 0100	600VAC/60Hz	E	Type 12	J	UL Recognized	R	
				150A – 0150	220VAC/50 or 60Hz	G	Type 3R	R	Component		
Fixed Mount Molded Case Breaker Normal Power Source, Molded Case Switch Emergency Power Source	C	Four	4	225A – 0225	380VAC/50Hz	H	Type 4 ^③	L			
				300A – 0300	600VAC/50Hz	K	Type 4X ^③	D	UL Listed and	C	
				400A – 0400	230VAC/50Hz	M			Meets Canadian		
				600A – 0600	401VAC/50Hz	N			Electrical Code		
				800A – 0800	415VAC/50Hz	O					
Fixed Mount Molded Case Switch Normal Power Source, Molded Case Breaker Emergency Power Source	D			1000A – 1000	240VAC/60Hz	W			No Listing	X	
					480VAC/60Hz	X					
					365VAC/50Hz	Z					

- ① Vertical orientation (225-1000 amperes)
- ② Horizontal orientation (30-150 amperes)
- ③ Contact factory for availability
- ④ Not all combinations are possible

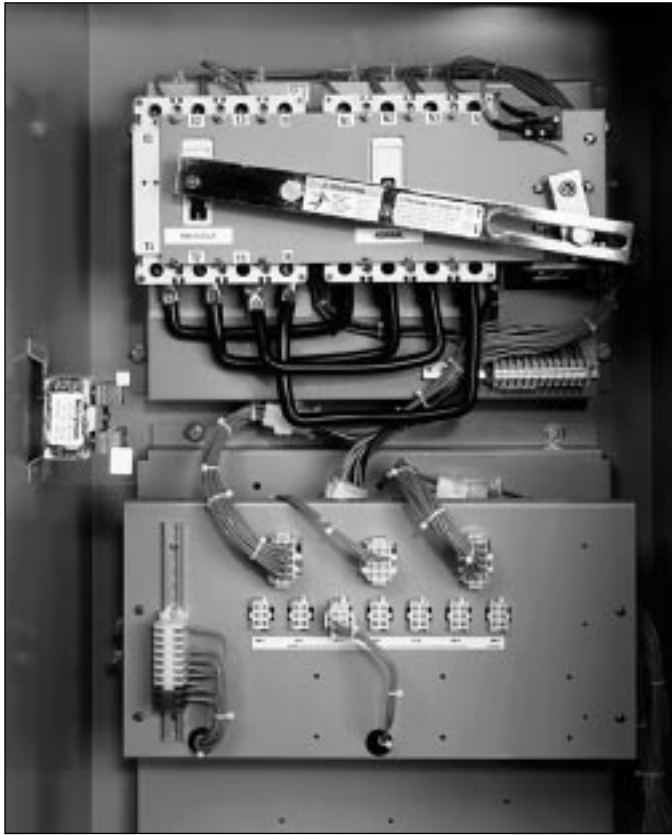

Figure 1-4 Horizontal Design Automatic Transfer Switch Equipment (30-150 Amperes)

SECTION 2: RECEIVING, HANDLING AND STORAGE

2.1 RECEIVING

Every effort is made to insure that transfer switch equipment arrives at its destination undamaged and ready for installation. Crating and packing is designed to protect internal components as well as the enclosure. Transfer switch enclosures are skid mounted and suited for fork lift movement. Care should be exercised, however, to protect the equipment from impact at all times. Do not remove protective packaging until the equipment is ready for installation.

When transfer switch equipment reaches its destination, the customer should inspect the shipping container for any obvious signs of rough handling and/or external damage incurred during the transportation phase. Record any external and internal damage observed for reporting to the transportation carrier and Cutler-Hammer, once a thorough inspection is completed. All claims should be as specific as possible and include shop order and general order numbers.



CAUTION

MAKE NOTE OF THE WARNING LABEL ATTACHED TO THE TOP OF THE SHIPPING CONTAINER THAT WARNS AGAINST DOUBLE STACKING TRANSFER SWITCH EQUIPMENT.

A shipping label is affixed to the top of the shipping container which includes a variety of equipment and customer information, such as General Order Number (GO#) and Catalog Number (Cat#). Make certain that this information matches other shipping paper information.

Each transfer switch enclosure is bolted through its top and bottom mounting flanges to a rigid wooden pallet. The pallet is open at two ends for movement by a fork lift. Heavy duty cardboard sides surround the enclosure and are further supported with reinforced cardboard corner posts.

An egg crate design cardboard protector covers the entire top of the enclosure with additional cardboard protectors over the indicating light panel and operating handle. A heavy duty cardboard lid covers the entire opening. The shipment is secured and further protected with shrink wrap. Do not discard the packing material until the equipment is ready for installation.

Once the top packaging is removed from the shipment, the enclosure door can be opened. A plastic bag of documents will be found within the enclosure, usually attached to the inside of the door. Important documents, such as test reports, wiring diagrams, appropriate instruction leaflets and a warranty registration card, are enclosed within the bag and should be filed in a safe place.

2.2 HANDLING

As previously mentioned, transfer switch equipment is packaged for fork lift movement. Protect the equipment from impact at all times and do not double stack. Once the equipment is in the installation location and ready to be installed, packaging material can be removed. Once the enclosure is unbolted from the wooden pallet, it can be hand moved to its installation position. Be careful not to damage the top or bottom enclosure mounting flanges. Refer to Section 4 of this manual for specific installation instructions.

2.3 STORAGE

Although well packaged, this equipment is not suitable for storage outdoors. The equipment warranty will not be applicable if there is evidence of outdoor storage. If the equipment is to be stored indoors for any period of time, it should be stored with its protective packaging material in place. Protect the equipment at all times from excessive moisture, construction dirt, corrosive conditions and other contaminants. It is strongly suggested that the package protected equipment be stored in a climate controlled environment of -20° to 85° with a relative humidity of 80% or less. Do not, under any circumstances, stack other equipment on top of a transfer switch equipment enclosure, whether packaged or not.

SECTION 3: EQUIPMENT DESCRIPTION

3.1 GENERAL

Cutler-Hammer transfer switch equipment is available in four different configurations:

- Automatic Transfer Switch
- Basic Transfer Switch
- Non-Automatic Transfer Switch (Manually Operated)
- Non-Automatic Transfer Switch (Electrically Operated)

Refer to Section 1 for a discussion of the four types. Each transfer switch is usually supplied in an enclosure, although unmounted sub-assemblies can be supplied for mounting by the customer. Since the enclosed automatic transfer switch encompasses all transfer switch equipment possibilities, it is the only specific type that will be discussed in this section.

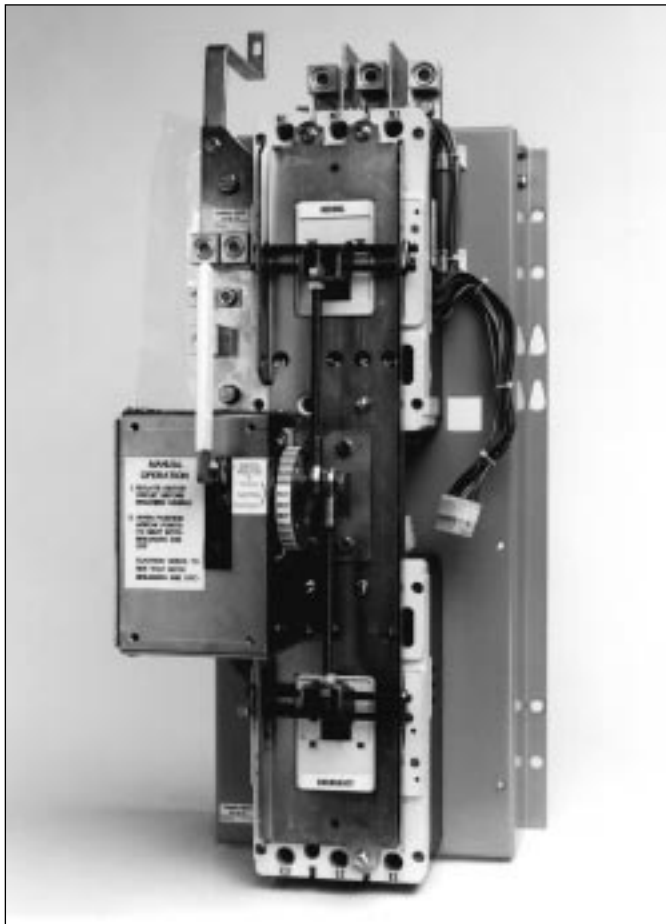

Figure 3-1 Typical Vertical Design Power Panel (Unmounted)

The enclosed automatic transfer switch consists of three basic panels interconnected through connector plugs and mounted in an enclosure (Figures 1-3, 1-4, 4-4 and 4-5):

- Power Panel
- Voltage Selection Panel
- Logic Panel
 - IQ Transfer
 - Solid State
 - Micro-processor based

The components comprising the three panels are installed in accordance with the specific requirements of the circuit being controlled. Each transfer switch is, therefore, tailor-made to a specific application.

3.2 POWER PANEL

The power panel consists of a means for making load, power and neutral connections, the main contacts and the transfer mechanism all on one steel base plate (Figures 3-1 and 3-2).

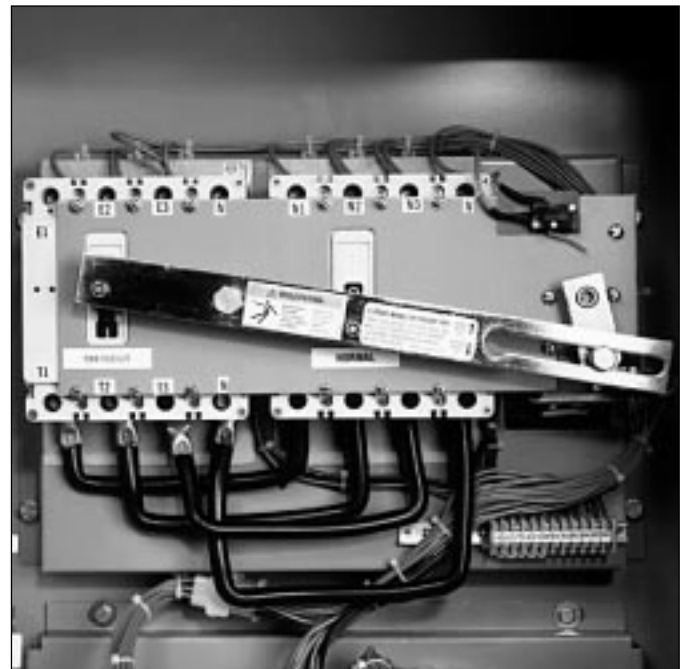

Figure 3-2 Typical Horizontal Design Power Panel (Mounted)

3.2.1 VERTICAL DESIGN STEEL BASE PLATE

The steel base plate on the vertical design permits the power panel to be moved vertically within the enclosure to accommodate top or bottom cable entry (Figure 4-2). Elongated holes on either side of the base plate insure proper positioning. The bottom set of elongated holes position the power panel higher in the enclosure, thus permitting bottom cable entry. The top set of elongated holes position the power panel lower in the enclosure for top cable entry. Section 4 discusses equipment mounting and load lug location in detail.

3.2.2 MAIN CONTACTS

The main contacts connect and disconnect the load to and from the different power sources. High withstand molded case switches are the main contacts for the Normal and Emergency power sources in standard, unmodified automatic transfer switches. Optional integral thermal and short circuit protection in either or both switching devices is, however, available (Figure 3-3 and Section 3.5). These continuous duty switches are rated for all classes of loads, open or enclosed. In addition, they have high dielectric strength, heavy-duty switching and withstand capabilities, and high interrupting capacity. The switches incorporate positive, quick-make, quick-break toggle mechanisms and De-ion arc chutes.

Vertically mounted switching devices are mechanically and electrically interlocked to prevent the two sets of main contacts from being closed simultaneously. The load side contacts of each switching device are joined with a bus bar assembly to form a common load terminal location, either top or bottom (Figure 4-3).

Horizontally mounted switching devices are also mechanically and electrically interlocked. The molded case switches are kept trip-free in the closed position. This permits thermal and short circuit protection to be incorporated in either or both interrupters.

3.2.3 VERTICAL DESIGN TRANSFER MECHANISM

The transfer mechanism transfers between power sources through a motor driven ratchet type operation. A rotational motion is created on an indicator wheel by the ratchet's operation. The indicator wheel is attached to rigid shafts which convert the rotary motion into vertical linear motion. Opening and closing of the switching devices is accomplished as a result of this vertical linear motion. The transfer mechanism is mounted in front of the molded case switches (Figure 3-1).

A solid steel shield attached to the ratchet assembly permits viewing of the rotary switch position indicator while restricting access to other parts of the power panel (Figure 1-2).

3.2.4 HORIZONTAL DESIGN TRANSFER MECHANISM

The horizontal design mechanism consists of a pivoting rocker-arm lever which operates the switch handles as the arm is moved by a rotating lever connected to the transfer motor. A slide pin engaging a pivot in the rotating lever converts rotary motion to linear motion. Motor limit switches are mounted externally to the molded case switches and operated by the rotating lever. Each limit switch is synchronized with its associated molded case switch to operate when its switch closes (Figure 3-2).

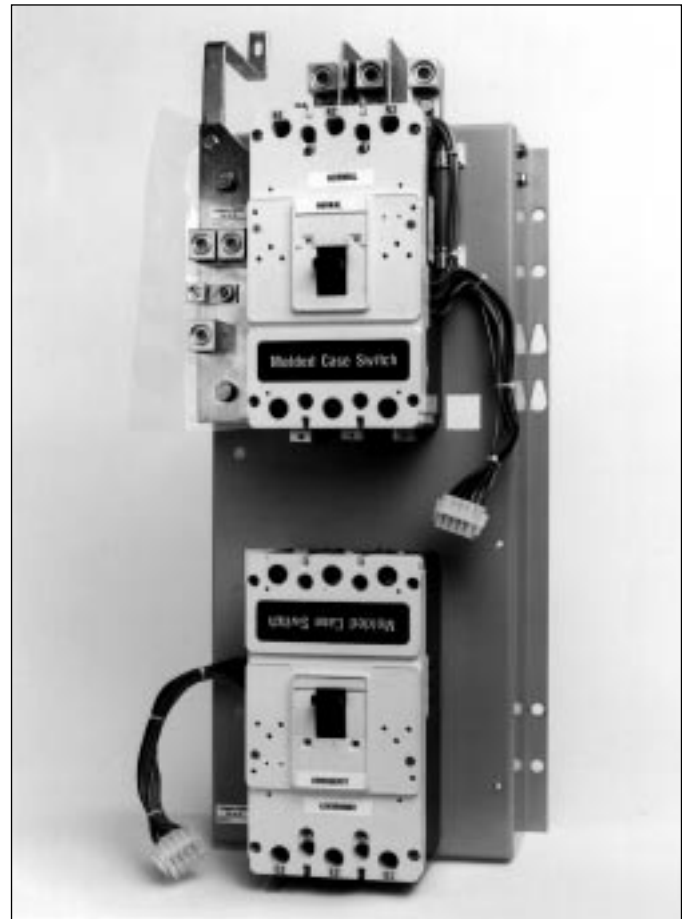

Figure 3-3 Molded Case Switches Mounted in Vertical Design (Transfer Mechanism Removed for Clarity)

3.3 VOLTAGE SELECTION PANEL

The voltage selection panel is a multi-tap enclosed transformer mounted in the enclosure (Figure 3-4). Seven front accessible voltages taps from 208 to 600 volts AC satisfy any required application voltage. A quick change capability from one voltage to another is provided by a small disconnect plug.

3.4 LOGIC PANEL

The logic panel provides the intelligence and supervisory circuits which constantly monitor the condition of both normal and emergency power sources thus providing the required intelligence for transfer operations (Figure 3-5). Three different possibilities are available with detailed information presented in separate documents:

- IQ Transfer Instruction Book
- Solid State Instruction Leaflet
- Micro-processor Based Instruction Leaflet

3.5 OPTIONS (NON-LOGIC PANEL)

Switch options, which are not part of the logic scheme, are available to meet a variety of other application requirements. Options are numbered with an associated description. More detailed selections that must be made within a specific option are lettered. For available options associated with the logic scheme, refer to the specific logic document associated with the type of logic selected.

NOTICE

*Options are Underwriters Laboratories, Inc. listed, except as noted, when supplied on UL Listed Switches. If an option is selected that is **Not UL Listed**, the switch **Will Not Have A UL Label**.*



Figure 3-4 Vertical Design Voltage Selection Panel with Voltage Being Selected



Figure 3-5 Typical Solid State Logic Panel (Door Mounted)

NOTICE

Not all options are available for all transfer switch configurations. If in doubt, check Price List 29-920 for the availability of options for a specific transfer switch design. The option numbers used here correspond to the numbers used in the price list.

14. Relay Auxiliary Contact

The Normal power source relay is energized only when the switch is in the Normal position and Normal power is present. The Emergency power source relay is energized whenever the Emergency power source is present.

- C. Normal Power Source: Provides 2 NO and 2 NC contacts
- D. Emergency Power Source: Provides 2 NO and 2 NC contacts

16. Power Switch with Integral Overcurrent Protection

Use of this option can, in many cases, eliminate the need for separate upstream overcurrent/short circuit protection, thus enabling code requirements to be met with a device that takes up less space and requires less wiring.

- B. Both Normal and Emergency Sides
- E. Emergency side only
- N. Normal side only

18. IQ Metering

- I. IQ Generator - Normal Only
- J. IQ Generator - Emergency Only
- K. IQ Generator - Both N&E (Selectable)
- O. IQ Analyzer - Normal Only
- P. IQ Analyzer - Emergency Only
- Q. IQ Analyzer - Both N&E (Selectable)
- R. DP-4000 - Normal Only
- S. DP-4000 - Emergency Only
- T. DP-4000 - Both N&E (Selectable)

20A. Rear Bus Connections

Front connected solderless lugs are furnished as standard on all enclosed and open units. Rear bus connections are only available on open units.

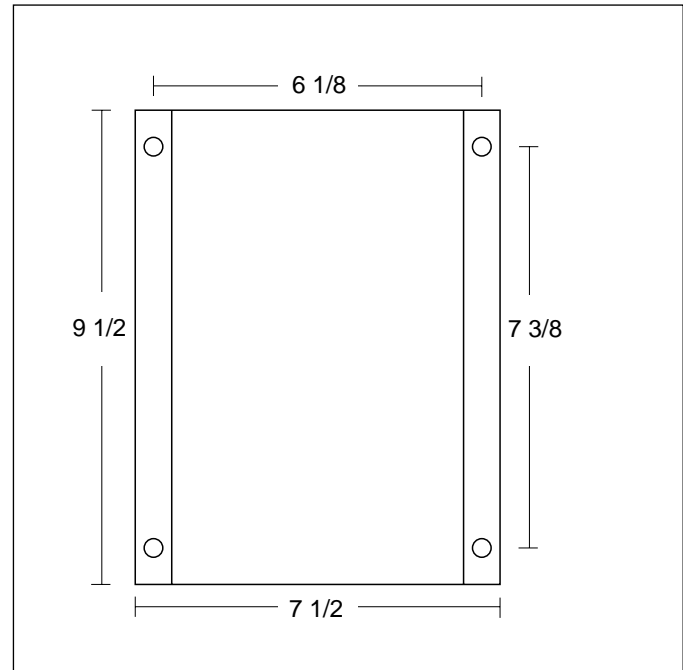

Figure 3-6 Charger Mounting Dimensions in inches (mm)

21A. Non-Standard Terminals

(Refer to Cutler-Hammer)

24. Battery Charger

The trickle charge DC output is 12 or 24 volts. Units are supplied in a separate wall mounted enclosure, and have an automatic high-low charge rate.

- C. 12 volt
- D. 24 volt

When supplied, the battery charger is provided in a separate wall mounted enclosure (Figure 3-6). Separate instructions and wiring information are provided with the charger for installation purposes.

NOTICE

A separate 120 VAC control power supply is required for the battery charger input. No connections between the transfer switch and battery charger should be made.

33. Shunt Trip

The shunt trip is wired to terminal blocks for customer connection. (120V coil supplied as standard.)

- A. Supplied in Normal Breaker
- B. Supplied in Emergency Breaker

34. Extender Cable

An extender cable provides a means for extending the distance between the power switching panel and the logic panel. This allows for remote mounting of the logic panel.

- A. 48 inch (1.2 m)
- B. 72 inch (1.8 m)
- C. 96 inch (2.4 m)
- D. 120 inch (3.0 m)
- E. 144 inch (3.7 m)

Special lengths are available. Contact Cutler-Hammer.

37. Service Entrance

- A. Provides transfer switch as suitable for service equipment rating - A key operated selector switch permits external, power operated service disconnection with external pilot light for disconnect indication, also includes Option 16.
- B. Same as A except includes ground fault protection.

41. Space Heater with Thermostat

- A. 100 Watts
- B. 200 Watts
- C. 400 Watts

42. Seismic Withstand Capability

Provides transfer switch with seismic capability exceeding the worst case Zone 4 required levels per both the **Uniform Building Code** and the **California Building Code**.

3.6 ENCLOSURE

The rugged steel switch enclosure is supplied with three door hinges, regardless of enclosure size, to insure proper support of the door and door mounted devices (Figures 3-6 and 4-1). The hinges have removable



Figure 3-7 Typical Type 1 Enclosure (Door Closed)

hinge pins to facilitate door removal. Certain procedures, such as switch mounting, are simplified with the door removed. The doors are supplied as standard with a key lockable handle.

The door is used to mount a variety of lights, switches and pushbuttons, depending upon the options required for a particular switch. All switch doors are supplied with a heavy duty plastic accessory panel in place, whether or not external devices are required. When lights, pushbuttons or switches are required, they are normally mounted in the plastic door mounted panel.

The rear of the enclosure is supplied with elongated holes in the top and bottom mounting flanges to facilitate mounting. The vertical design is also supplied with two positioning bolts and various pre-tapped inserts to insure proper positioning of the power panel, anytime the power panel must be repositioned to accommodate a different

Table 3.1 Transfer Switch Equipment Enclosures

NEMA Type	Design	Protection
1	Indoor	Enclosed Equipment
3R	Outdoor	Rain, Ice Formation
12	Indoor	Dust, Dirt and Non-corrosive Liquids
4/4X	Indoor/Outdoor	Dust, Rain, Splashing Water, Corrosion Resistant

cable entry position. Cable entry holes are the responsibility of the customer.

Transfer switch enclosures and all internal steel mounting plates, such as the power panel mounting plate, go through a pre-treatment cleaning system prior to painting to insure a durable finish.

The standard switch enclosure is NEMA Type 1 for general indoor use. A variety of enclosures are, however, available to address almost any environmental circumstance (Table 3.1).

3.7 STANDARDS

Cutler-Hammer transfer switch equipment enclosed in a NEMA 1 enclosure is listed for application by UL. In addition, Cutler-Hammer Automatic Transfer Switches are listed in File E38116 by Underwriters Laboratories, Inc. under Standard UL 1008. This standard covers requirements for automatic transfer switches intended for use in ordinary locations to provide for lighting and power as follows:

- a. In emergency systems, in accordance with articles 517 and 700 in the National Electrical Code, ANSI/NFPA 70 and the National Fire Protection Association No. 76A and/or
- b. In stand-by systems, in accordance with article 702 of the National Electrical Code and/or
- c. In legally required stand-by systems in accordance with article 701 of the National Electrical Code.

Cutler-Hammer Automatic Transfer Switches are available to meet NFPA 110 for emergency and stand-by power systems, and NFPA99 for health care facilities when ordered with the appropriate options.

Since Cutler-Hammer Automatic Transfer Switches utilize specially designed molded case switches and/or molded case circuit breakers as the main power switching contacts, these devices must also be listed under the additional UL Standards 489 and 1087. Underwriters laboratories utilize two basic types of listing programs: a) Label service b) Re-examination. UL489 and UL1087 employ a label service listing program which requires an extensive follow-up testing program for listed devices. Standard UL1008 for automatic transfer switches lists devices under the re-examination program which only requires a continual physical re-examination of the components used in the product to insure consistency with the originally submitted device. Follow-up testing is not required by UL1008.

Representative production samples of molded case switches and molded case circuit breakers used in Cutler-Hammer Automatic Transfer Switches are subjected to a complete test program identical to the originally submitted devices on an ongoing periodic basis per UL489 and UL1087. The frequency of such a re-submittal can be as often as every quarter for a low ampere device.

SECTION 4: INSTALLATION AND WIRING

4.1 GENERAL

Transfer switches are factory wired and tested. Installation requires solidly mounting the enclosed unit and connecting power cables and auxiliary pilot circuits. Physical mounting procedures and power cable connections are covered in this section. All other required wiring or electrical connection references are covered in a separate **Customer Wiring Booklet** packed with the transfer switch. Locate the wiring booklet, review it, and keep it readily available for reference purposes during installation and testing. Once a transfer switch is properly installed and wired, it should be mechanically and electrically checked for proper installation and operation. The procedures for these initial mechanical and electrical checks are outlined in Section 6 of this instruction manual.

NOTICE

To facilitate the procedures described in this section for the vertical design, remove the solid steel shield over the power panel. The shield is attached to the ratchet assembly with four screws. Remove the four screws and shield until the procedures are completed.



WARNING

BE CERTAIN THAT THE SOLID STEEL POWER PANEL SHIELD USED WITH THE VERTICAL DESIGN IS PROPERLY INSTALLED BEFORE TRANSFER SWITCH EQUIPMENT IS PUT INTO SERVICE. THE SHIELD PROVIDES PROTECTION FROM DANGEROUS VOLTAGES AT THE LINE AND LOAD TERMINALS WHEN THE EQUIPMENT IS IN OPERATION. FAILURE TO DO SO COULD RESULT IN PERSONAL INJURY OR DEATH.

4.2 MOUNTING LOCATION

Choose a location that offers a flat, rigid mounting surface capable of supporting the weight of the enclosed transfer switch equipment (Figure 4-1). Avoid locations that are moist, hot and/or dusty. Enclosure designs are, however, available for special environments. If there are any doubts as to location suitability, discuss it with your Cutler-Hammer representative.

Check to make certain that there are no pipes, wires or other mounting hazards in the immediate mounting area that could create a present or future problem.

Carefully remove all packing material from the transfer switch at the mounting location. Even though an equipment inspection was made when the equipment was received, make another careful inspection of the enclosure and the enclosed transfer switch as packing material is removed and the enclosure readied for mounting. Be especially alert for distorted metal, loose wires or damaged components.

4.3 MOUNTING PROCEDURE



CAUTION

SINCE THE ENCLOSED TRANSFER SWITCH MUST BE LIFTED INTO PLACE FOR MOUNTING, BE CERTAIN THAT ADEQUATE RESOURCES ARE AVAILABLE FOR LIFTING TO AVOID PERSONNEL INJURIES OR EQUIPMENT DAMAGE.

Refer to Figure 4-1 for enclosure mounting dimension references. All transfer switch equipment enclosures are of the same design. Only the overall physical dimensions change. The enclosure is provided with four elongated mounting holes, two in the top mounting flange and two in the bottom.

If the transfer switch equipment is of the vertical design, the power panel is provided with two sets of mounting holes. One set positions the panel for top entry of cables and one set for bottom entry (Figure 4-2). This will be covered in more detail later in this section under "Load Lug Location."

Transfer switch equipment is assembled and supplied as standard for top entry, although equally adaptable to bottom entry. Cable entry holes are not part of the enclosure when shipped from the factory and must be provided in the field, either before or after mounting the enclosure.



CAUTION

EXTREME CARE SHOULD BE TAKEN TO PROTECT THE TRANSFER SWITCH FROM DRILL CHIPS, FILINGS AND OTHER CONTAMINANTS WHEN MAKING THE CABLE ENTRY HOLES AND MOUNTING THE ENCLOSURE TO PREVENT COMPONENT DAMAGE OR A FUTURE MALFUNCTION.

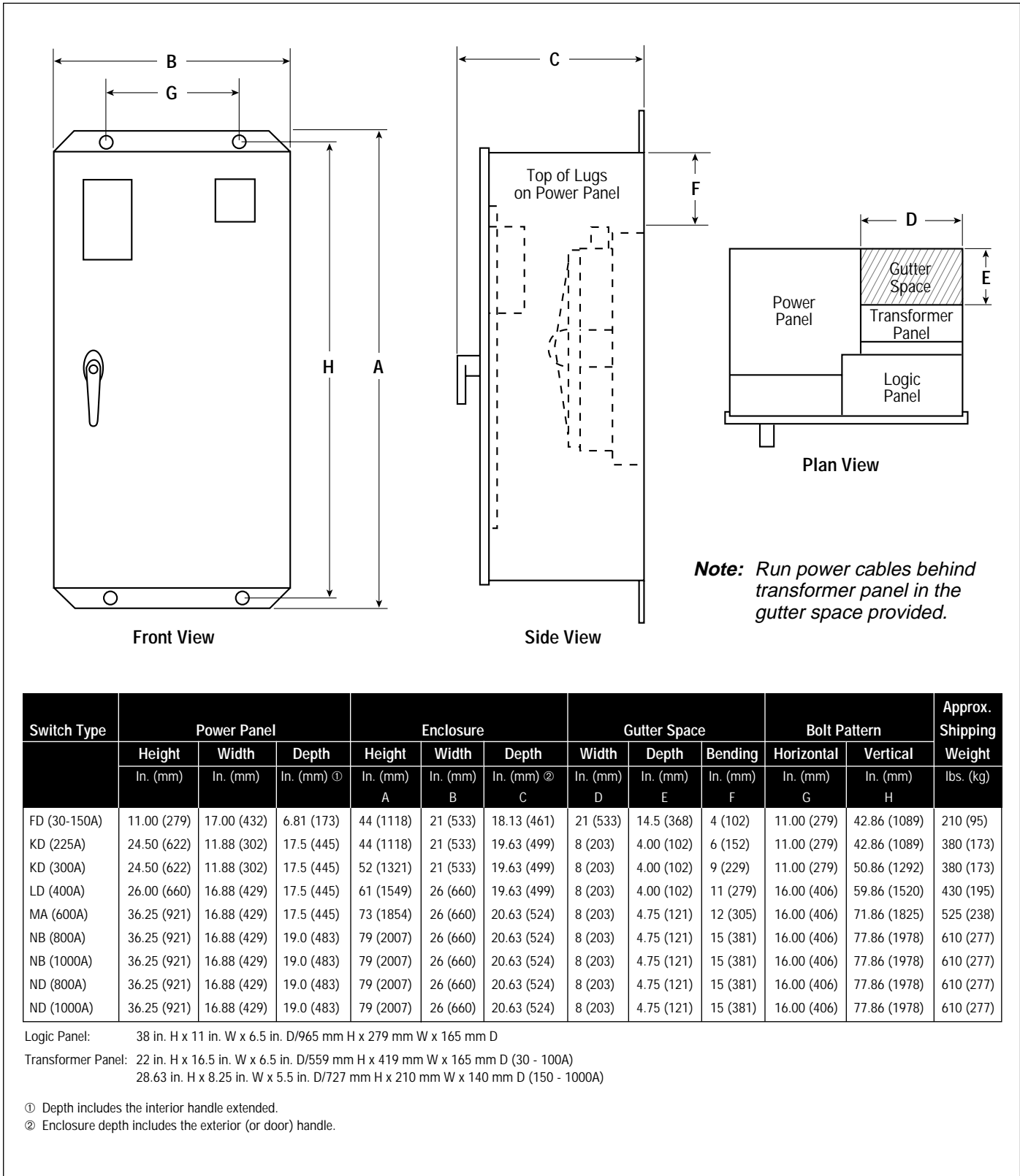

Figure 4-1 Enclosed Automatic Transfer Switch Dimensions and Approximate Weights

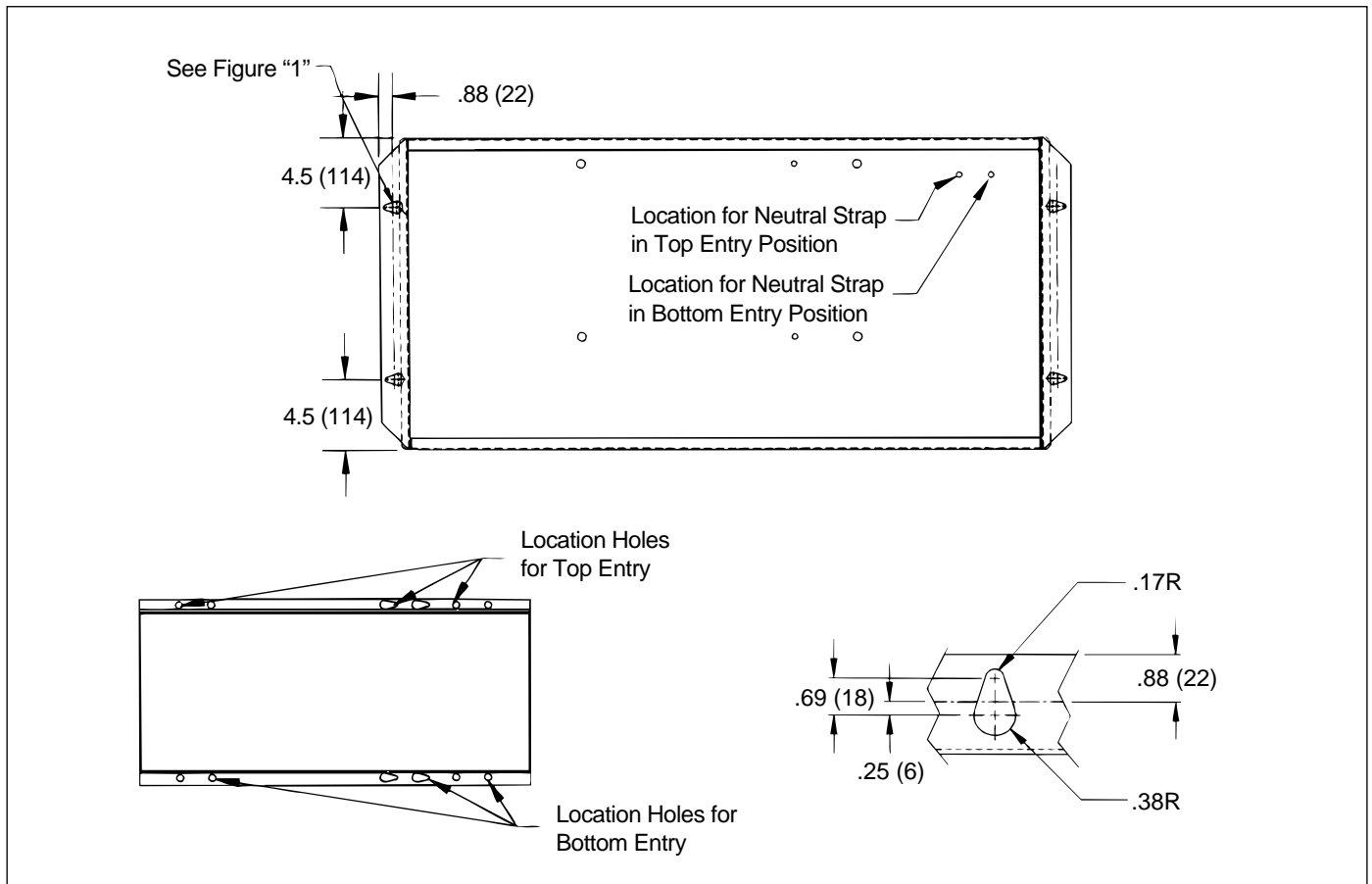

Figure 4-2 Vertical Design Power Panel Mounting Reference in Inches (mm)

With the enclosed transfer switch equipment unpacked and ready for mounting, proceed with the following steps:

- Step 1:** The transfer switch enclosure door is hinge mounted with removable hinge pins. To simplify the mounting procedure and avoid damaging the door mounted logic panel, carefully remove the door and set aside in a safe place until mounting is complete.
- Step 2:** Install required mounting bolt anchors and the two upper mounting bolts in the mounting surface.
- Step 3:** Gently lift the enclosure and guide the elongated holes in the upper mounting flange over the upper mounting bolts, but do not completely tighten the bolts.

Step 4: While still supporting the enclosure, install the two lower mounting bolts in the lower mounting flange, but do not completely tighten. Use shims, if required, to prevent deformation of the enclosure when the mounting surface is distorted.

Step 5: Tighten all four mounting bolts after any required shimming is completed.

Step 6: Double check to ensure that all packing and shipping material has been removed.

4.4 VERTICAL DESIGN LOAD LUG LOCATION

Transfer switch equipment is supplied as standard from the factory with its load terminal lugs at the top. If the

load lugs are to be repositioned to the bottom, do it at this time before wiring the unit or making power cable connections.



WARNING

IF THE LOAD LUG LOCATION IS BEING CHANGED ON ALREADY INSTALLED TRANSFER SWITCH EQUIPMENT, MAKE SURE THAT THE NORMAL, EMERGENCY AND OTHER POWER SOURCES CONNECTED TO THE EQUIPMENT ARE DE-ENERGIZED. HAZARDOUS VOLTAGES ARE PRESENT INSIDE TRANSFER SWITCH EQUIPMENT AND CAN CAUSE SEVERE PERSONAL INJURY OR DEATH.

With the solid steel shield removed, proceed with the following steps (Figure 1-3):



Figure 4-3 Vertical Design Load Lug Assembly Shown Mounted

Step 1: Disconnect the power panel from the rest of the transfer switch by unplugging the connector plugs (S1, S2 and S3) (Figure 4-4).

Step 2: Remove the bolt that bonds the neutral strap to the rear of the enclosure, if it is in place

Step 3: Remove the four bolts that secure the power panel in the enclosure. Depending upon the size of the panel, it may be advisable to have assistance with the removal. Once the power panel is free, carefully move it to a solid work surface (Figure 3-1).

NOTICE

At this point, take the time to refer to Figure 4-2 and become familiar with the inside rear of the enclosure and the power panel mounting provisions available for both top and bottom entry. It will facilitate re-installation of the power panel.

Step 4: Remove the operating mechanism from the front of the power panel by removing the six bolts holding the mechanism in position. The molded case switches or optional circuit breakers do not have to be removed (Figure 3-3).

NOTICE

The rear mounted load lugs, dip insulated bus bars, standoff insulators, glass polyester phase barriers, and metal mounting bracket are designed to be removed as one load lug assembly (Figure 4-3).

Step 5: The load lug assembly, just mentioned, is removed by first removing the six or eight bolts securing the pieces of insulated bus to the back of the power panel. The number of mounting bolts depends upon whether 3 or 4-pole devices are installed. Mounting bolts are accessed through holes in the load end of the molded case switches or optional circuit breakers.

Step 6: Next, remove the 4 bolts holding the mounting bracket to the upper rear portion of the power panel. The load lug assembly can now be removed as one unit. Note that there are grooves in the back of the power panel and in the mounting bracket that keep the polyester phase barriers in their proper positions.

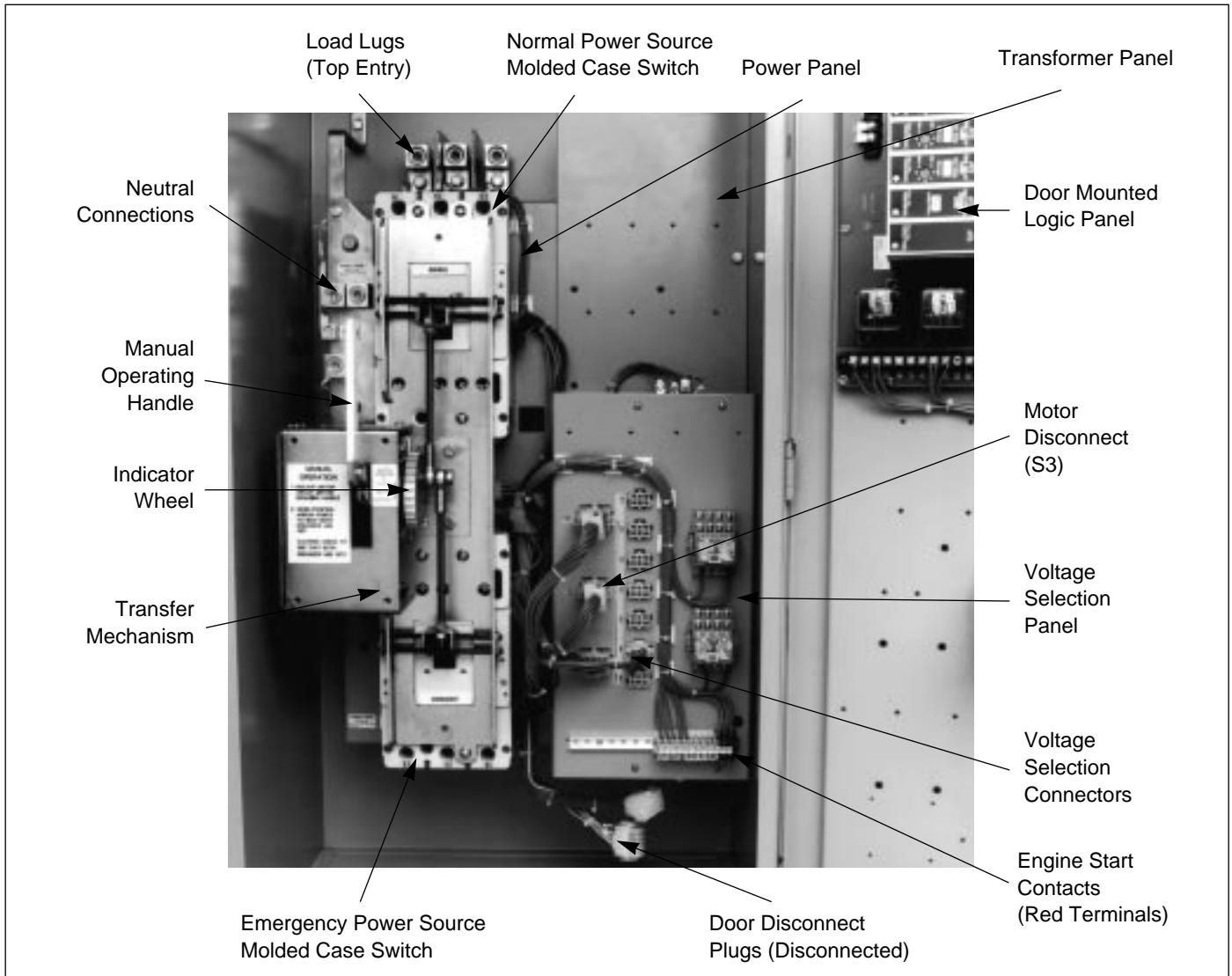

Figure 4-4 Typical (225-1000 Amperes) Vertical Design Transfer Switch Equipment (Door Open and Deadfront Shield Removed)

Step 7: Turn the load lug assembly 180° with the lugs at the bottom and remount the assembly by reversing the procedures described in Steps 5 and 6. The mounting bracket will now be bolted to the bottom of the power panel. Make certain that all glass polyester phase barriers are in place and positioned properly in the grooves provided. When making any bolted connection to the bus, comply with the torque requirements as outlined in Table 4.1.

Table 4.1 Bolted Bus Connection Torque Requirements

Power Panel Switching Device	Torque in-lb (Nm)
Type FD	10 (13)
Type KD	20 (27)
Type LD	25 (33.8)
Type MA	25 (33.8)
Type ND/NB	25 (33.8)

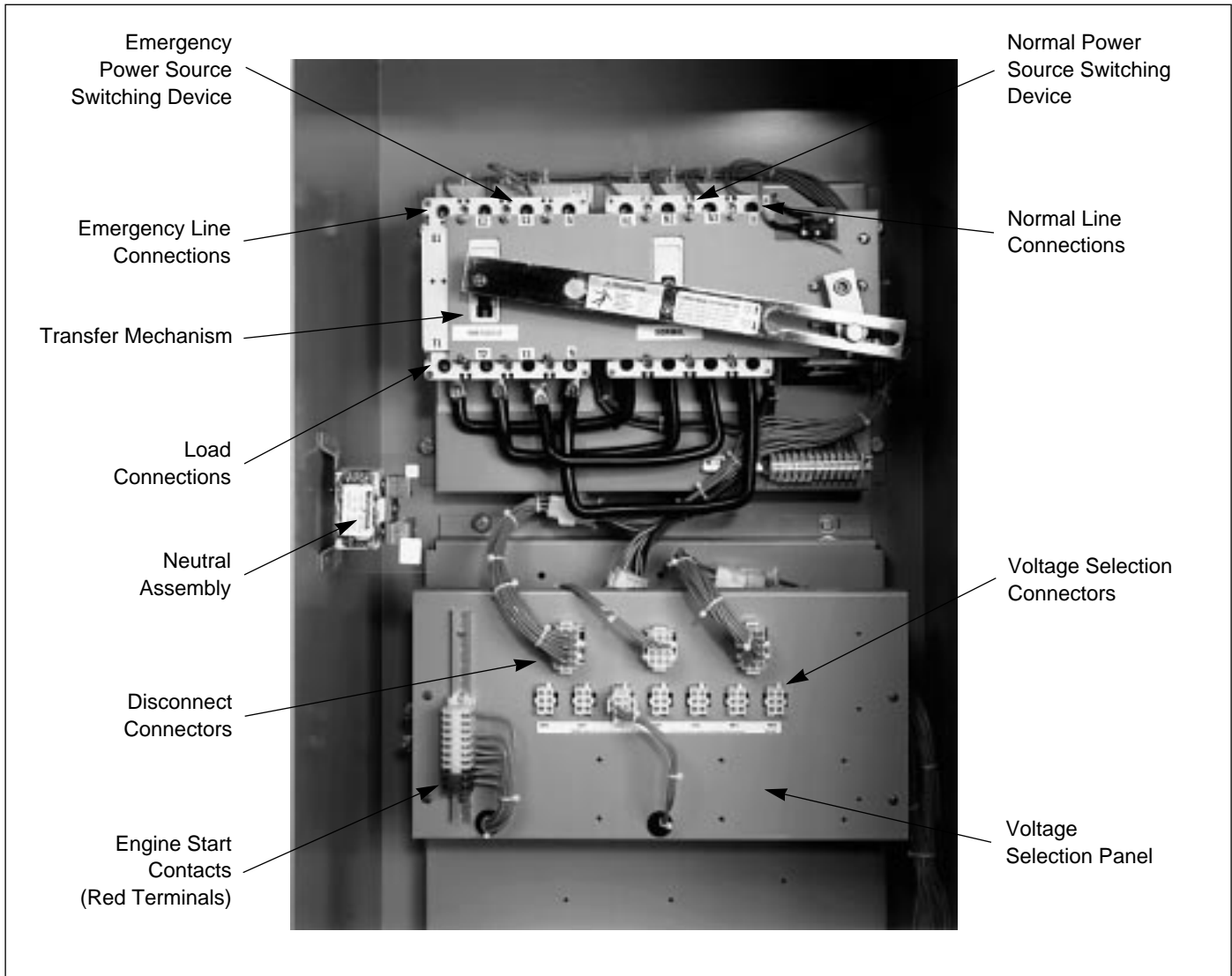

Figure 4-5 Typical (30-150 Amperes) Horizontal Design Transfer Switch Equipment (Door Open)

Step 8: Remount the operating mechanism to the front of the power panel with the six bolts removed previously in Step 4.

Step 9: Position the power panel in the enclosure such that the two upper elongated holes, one on either side of the power panel, fit over the two positioning bolts located in the rear of the enclosure. This will line up the four correct mounting holes in the power panel with the pre-tapped inserts in the rear of the enclosure.

Step 10: With the power panel held securely against the back of the enclosure, replace and tighten the four mounting bolts removed previously in Step 3.

Step 11: Attach the neutral strap to the back of the enclosure through the upper bonding hole, which may or may not have been previously removed in Step 2

Step 12: Reconnect the connector plugs and the transfer switch equipment is now configured for bottom entry.

4.5 POWER CABLE CONNECTIONS



WARNING

POWER CONDUCTORS MAY HAVE VOLTAGE PRESENT THAT CAN CAUSE SEVERE PERSONAL INJURY OR DEATH. DE-ENERGIZE ALL POWER OR CONTROL CIRCUIT CONDUCTORS TO BE CONNECTED TO THE TRANSFER SWITCH EQUIPMENT BEFORE BEGINNING TO WORK WITH THE CONDUCTORS AND/OR TERMINATING THEM TO THE EQUIPMENT.



CAUTION

USE OF CABLE LUGS NOT DESIGNED FOR THE TRANSFER SWITCH MAY CAUSE HEATING PROBLEMS. BREAKER LUGS ONLY MOUNT TO THE BREAKER, WHILE TRANSFER SWITCH LUGS MOUNT TO BOTH THE BREAKER AND THE BUSBAR BEHIND THE BREAKER. FOR INSTALLATION INSTRUCTIONS, REFER TO THE INSTRUCTION LEAFLET SUPPLIED FOR THE SPECIFIC LUGS.



CAUTION

TO HELP PREVENT COMPONENT DAMAGE OR FUTURE MALFUNCTIONS, USE EXTREME CARE TO KEEP CONTAMINANTS OUT OF THE TRANSFER SWITCH EQUIPMENT WHEN MAKING POWER CABLE CONNECTIONS.

Proceed with the following steps:

- Step 1:** Verify that the line and load cables comply with applicable electrical codes.
- Step 2:** Verify that transfer switch rated current and voltage (see identification plate on the intelligence panel of transfer switch) agree with system current and voltage.
- Step 3:** After the transfer switch is mounted, provide conduit or cable openings as required. Ensure that no metal filings contaminate the transfer switch components.
- Step 4:** Test all power cables before connecting to the unit to insure that conductors or cable insulation have not been damaged while being pulled into position.

- Step 5:** Carefully strip insulation from the power cables. Avoid nicking or ringing of the conductor strands. Prepare the stripped conductor termination end by cleaning it with a wire brush. If aluminum conductors are used, apply an appropriate joint compound to the clean conductor surface area. Refer to Figure 4-3 for approximate locations of power connections.

Power cables are to be connected to solderless screw type lugs located on the transfer switch switching devices. Verify that the lugs supplied will accommodate the power cables being used. Also verify that the cables comply with local electrical codes. Standard transfer switch equipment, as supplied from the factory, will accommodate the wire sizes shown in Table 4.2.



CAUTION

IMPROPER POWER CABLE CONNECTIONS CAN CAUSE EXCESSIVE HEAT AND SUBSEQUENT EQUIPMENT FAILURE.

- Step 6:** Tighten cable lugs to the torque identified on the label affixed to the unit immediately adjacent to the lugs.
- Step 7:** Make necessary connections of options using wiring diagrams supplied with the unit.
- Step 8:** Connect engine start wires to the red terminal blocks marked S1 and S2.

Table 4.2 Transfer Switch Equipment Wire Sizes

Transfer Switch Amp Rating	Wire Size Range	Number of Cables per Phase
30-150	#4 - 2/0	1
150-300	#3 - 350 MCM	1
400	250 - 350 MCM	2
600 (3P)	#1 - 500 MCM	2
600 (4P)	3/0 - 400 MCM	3
800	3/0 - 400 MCM	3
1000	4/0 - 500 MCM	4

**CAUTION**

DO NOT RUN POWER CABLES BEHIND OR TO THE LEFT OF THE POWER PANEL. THE CABLES SHOULD BE RUN IN THE GUTTER SPACE PROVIDED AS SHOWN IN FIGURE 4-1. RUNNING THE CABLES IN PLACES NOT RECOMMENDED COULD INTERFERE WITH THE PROPER OPERATION OF THE TRANSFER SWITCH.

NOTICE

Remember to re-attach the solid steel power panel deadfront shield to the ratchet assembly on the vertical design after completing any of the procedures described in this section.

4.6 WIRING**CAUTION**

POWER CONDUCTORS AND CONTROL WIRING MAY HAVE VOLTAGE PRESENT THAT CAN CAUSE SEVERE PERSONAL INJURY OR DEATH. DE-ENERGIZE ALL POWER OR CONTROL CIRCUIT CONDUCTORS BEFORE BEGINNING TO PERFORM ANY WIRING ACTIVITY TO OR WITHIN THE TRANSFER SWITCH EQUIPMENT.

Power sources, load conductors and control wiring should be connected to locations as indicated in the **Customer Wiring Booklet** supplied with the transfer switch equipment.

**CAUTION**

DO NOT RUN POWER CABLES BEHIND OR TO THE LEFT OF THE POWER PANEL. THE CABLES SHOULD BE RUN IN THE GUTTER SPACE PROVIDED AS SHOWN IN FIGURE 4-1. RUNNING THE CABLES IN PLACES NOT RECOMMENDED COULD INTERFERE WITH THE PROPER OPERATION OF THE TRANSFER SWITCH.

**CAUTION**

CHECK THE TRANSFER SWITCH EQUIPMENT NAMEPLATE FOR RATED VOLTAGE. IT SHOULD BE THE SAME AS THE NORMAL AND EMERGENCY LINE VOLTAGES. OPERATING THE EQUIPMENT ON IMPROPER VOLTAGE CAN CAUSE EQUIPMENT DAMAGE.

Once the transfer switch equipment has been installed and wired, perform initial mechanical and electrical procedures as outlined in Section 6 to verify that the equipment is installed and operating properly.

NOTICE

Remember to re-attach the solid steel power panel deadfront shield to the ratchet assembly on the vertical design after completing any of the procedures described in this section.

4.7 VOLTAGE SELECTION ADJUSTMENTS

Certain devices, such as the Voltage Selection Panel, sensing relays and timers, need to be set and/or calibrated prior to placing the transfer switch equipment into service. Adjustments for logic devices are described in the separate instructional document dedicated to the specific logic being used. Voltage selection adjustments are described here.



Figure 4-6 Line Voltage Plug and Receptacles (shown with covers removed) for Horizontal Design

**CAUTION**

BE SURE THAT THE CORRECT VOLTAGE IS SELECTED TO MATCH THE SYSTEM VOLTAGE. AN IMPROPER SELECTION AND/OR CONNECTION COULD RESULT IN EQUIPMENT DAMAGE.

Vertical Design Voltage Selection

The vertical design transfer switch is furnished with a multi-tap Voltage Selection Panel to the right of the power panel. Seven front accessible taps from 208 to 600 volts AC are provided (Figure 3-4). A small disconnect plug is provided to change from one voltage to another.

Horizontal Design Voltage Selection

Horizontal design transfer switches are furnished with an adjustable line voltage plug and receptacles below the power panel. To change the line voltage, remove the covers and insert the plug in the desired receptacle (Figure 4-6).

SECTION 5: OPERATION

5.1 GENERAL

A transfer switch provides main contacts to connect and disconnect the load to and from the normal and emergency power sources (Paragraph 3.2.2). A transfer mechanism provides the mechanical motion required to open and close the mechanically interlocked main contacts (Paragraphs 3.2.3, 3.2.4 and Figure 3-3).

Three distinct switch positions are provided:

- **Normal** - The contacts associated with the normal power source are closed and the emergency power source contacts are open.
- **Neutral** - The contacts associated with both the normal power source and emergency power source are open. This position allows for load circuit maintenance.
- **Emergency** - The contacts associated with the normal power source are open and the emergency power source contacts are closed.

5.2 VERTICAL DESIGN OPERATION

The vertical design transfer switch utilizes a mechanical mechanism with a manual operating handle (Figure 4-4). The manual operating handle can be used to create the rotational motion required to open and close the main contacts through a rigid mechanical interlocking system (Figure 5-1). An indicator wheel attached to the operating handle and mechanical interlocking system rotates with each movement of the handle to open and/or close the main contacts (Figure 5-2). The three switch positions (Normal, Neutral and Emergency) are visually indicated on the indicator wheel (Figure 5-3).

To manually operate the transfer switch, the operating handle is ratcheted until the desired switch position is indicated on the indicator wheel. The operating handle is always electrically “dead,” and the indicator wheel free-wheels should a particular switch be capable of electrical operation through the use of a motor. This feature ensures no operator problems should the switch automatically operate while the manual handle is being used.



Figure 5-1 Transfer Switch Manual Operating Handle in Use on Vertical Design

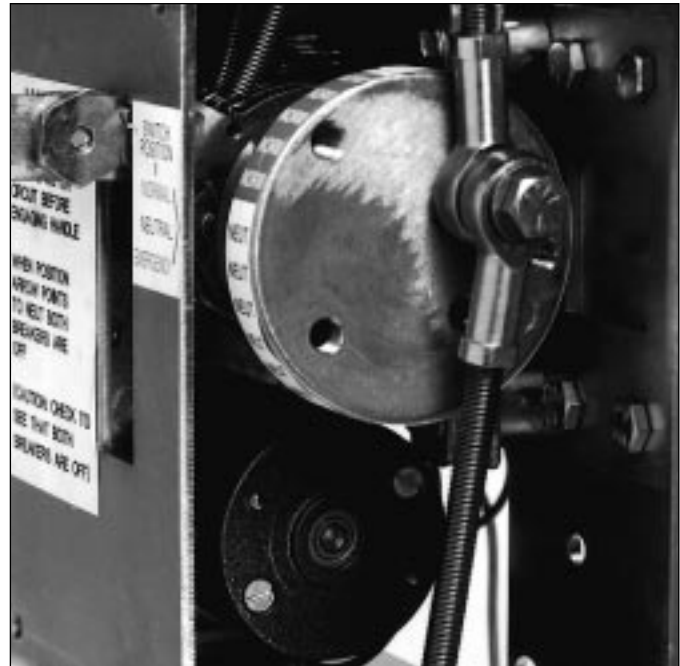

Figure 5-2 Indicator Wheel Shown Mounted in Mechanism with Motor Mounted Under Wheel

NOTICE

If a transfer switch with any kind of electrical operating capabilities is to be operated manually utilizing the manual operating handle, it is strongly recommended that the transfer motor circuit first be isolated. This is accomplished by unplugging the (S3) plug marked motor disconnect (Figure 5-4). If, however, a transfer switch is supplied with a four position selector switch (Option 6H), it can be turned to the “OFF” position, making it unnecessary to unplug the plug. In the case of the automatic transfer switch design, any attempt to operate the manual handle without first isolating the motor circuit causes an automatic transfer.

5.3 HORIZONTAL DESIGN OPERATION

The horizontal design transfer switch utilizes a pivoting rocker-arm lever which operates the circuit breaker handles as the arm is moved by a rotating lever usually connected to a transfer motor (Figure 4-5). A slide pin engaging a pivot in the rotating lever converts rotary motion to linear motion. Motor limit switches, for motor

equipped transfer switches, are mounted external to the molded case switches and operated by the rotating lever. Each limit switch is synchronized with its associated switch to operate when the switch closes.

When manually operating the transfer switch, the transfer motor circuit should first be isolated by unplugging the disconnect link. Unscrew the rotating lever slide pin in the rocker arm lever and remove it. The slide pin is a left-hand thread and is removed by unscrewing clockwise. Pivot the rocker arm lever until the desired position is achieved. No special tools are required for this operation. The rocker arm lever nameplate indicates the switch position (Normal, Neutral and Emergency).

NOTICE

If a transfer switch with any kind of electrical operating capabilities is to be operated manually, it is strongly recommended that the transfer motor circuit first be isolated. This is accomplished by unplugging the disconnect link. In the case of the automatic transfer switch design, any attempt to operate the manual handle without first isolating the motor circuit causes an automatic transfer.

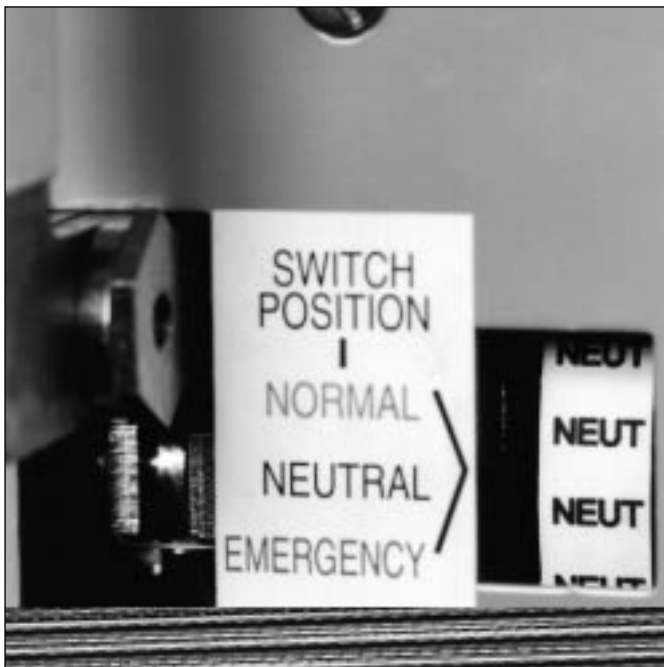

Figure 5-3 Indicator Wheel Indicating Neutral Position on Vertical Design

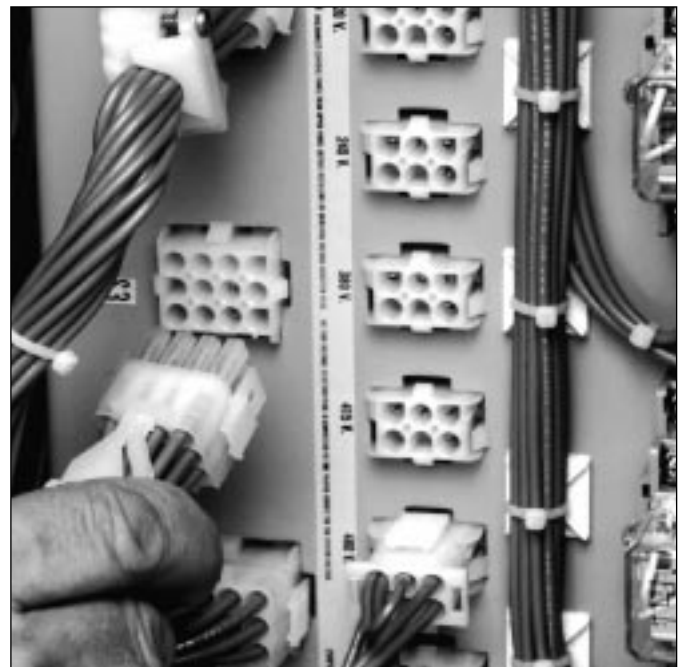

Figure 5-4 Motor Disconnect Being Unplugged

5.4 NON-AUTOMATIC OPERATION (MANUALLY OPERATED)

A non-automatic (manually operated) transfer switch (Paragraph 1.2.1) functions as described in Paragraphs 5.1 through 5.3. All transfer operations are accomplished by true hand operation, with no power assistance of any kind.

5.5 NON-AUTOMATIC OPERATION (ELECTRICALLY OPERATED)

A non-automatic (electrically operated) transfer switch (Paragraph 1.2.1) functions similarly to the non-automatic (manually operated) transfer switch except for the addition of an electrical operating feature. This feature permits the main contacts to be opened or closed electrically. There is, however, no intelligence circuit associated with this design.

Electrical operation is accomplished by adding a motor and required circuitry to the manual mechanism and wiring it to a pushbutton on the front of the enclosure (Figure 5-5). The pushbutton can be pushed to test the transfer switch or held to make an electrical transfer. The switch's operating position can be visually indicated on the front of the enclosure by using optional indicating lights.



Figure 5-5 Electrical Operation Pushbutton and Position Indicating Lights Shown Mounted

Pushing and holding the pushbutton causes the motor to operate and automatically transfer the load by opening and closing the main contacts. Since an intelligence circuit is not part of the design, operation of the pushbutton is required each time an electrical transfer is required, whether it is from Normal to Emergency or vice versa.

5.6 AUTOMATIC TRANSFER SWITCH

The automatic transfer switch incorporates all the features and utilizes the same designs as the switches described in Paragraphs 5.4 and 5.5, except that intelligence and supervisory capabilities are added to the switch by the addition of a logic panel in the enclosure or on the enclosure door (Figures 1-4 and 3-5). The logic panel can be as sophisticated or simple as required, depending upon the number and types of options selected.

The operating sequence of an automatic transfer switch is dictated by the switch's standard features and selected options. Operation of an automatic transfer switch during normal source failure and normal source restoration will be described here with only standard options included on the switch. Additional options, as described in the separate instructional document dedicated to the specific logic being used, can change sequences and timing, depending upon the options selected. Refer to paragraph 3.4. Become familiar with additional options selected and their effect on the normal operation of an automatic transfer switch.

Normal Power Source Failure

Standard normal power source failure is defined as a reduction or loss of voltage. If this occurs, the sequence of operation is as follows:

- Failure of the normal power source is detected by the logic.
- When the logic detects a failure, it will close a contact which starts the engine driven generator.
- When the emergency power source voltage and frequency reaches its operation range, the logic begins the transfer operation. This operating sequence opens the Normal Power Source Switching Device (NB) and closes the Emergency Power Source Switching Device (EB).
- The load is now transferred to emergency power source.

Normal Source Restoration

- A return to the normal power source begins when the voltage in all phases of a three phase sensing unit or line-to-line in a single phase sensing unit is restored to its operating range.
- At preset levels, the logic starts the return to the normal power source and normal transfer switch operation.
- During this sequence, the Emergency Power Source Switching Device is opened and the Normal Power Source Switching Device is closed.
- Simultaneously, the logic initiates the shut down of the engine driven generator.
- Transfer of the load back to the normal power source is now completed.

SECTION 6: TESTING AND PROBLEM SOLVING

6.1 TESTING

After transfer switch equipment is initially installed or during planned outages, the installation should be tested to insure that all equipment operates properly. This attention to detail will help to avoid unexpected malfunctions. Mechanical and/or electrical tests should be performed.

The frequency of subsequent testing should be based on recommendations of the generator set manufacturer. Use the test pushbutton to check the electrical operation of the switch. **IF A TEST SWITCH IS PROVIDED, ALWAYS RETURN THE SWITCH TO THE AUTO POSITION AFTER THE TEST IS COMPLETE.**



WARNING

HIGH VOLTAGES ASSOCIATED WITH OPERATIONAL TRANSFER SWITCH EQUIPMENT PRESENT A SHOCK HAZARD THAT CAN CAUSE SEVERE PERSONAL INJURY OR DEATH. USE EXTREME CAUTION TO AVOID TOUCHING ELECTRICAL CONNECTIONS WHENEVER INSPECTING OR TESTING THE EQUIPMENT.

IN ADDITION, IMPROPER OPERATION OF THE GENERATOR SET PRESENTS A HAZARD THAT CAN CAUSE SEVERE PERSONAL INJURY OR DEATH. OBSERVE ALL SAFETY PRECAUTIONS IN YOUR GENERATOR SET OPERATIONS AND INSTALLATION MANUALS.

For mechanical operations, refer to Section 5 in this instruction book. Refer to the applicable logic instruction manual for electrical testing. Refer to paragraph 3.4 for logic instruction manuals.

6.2 PROBLEM SOLVING



WARNING

HAZARDOUS VOLTAGES IN AND AROUND TRANSFER SWITCH EQUIPMENT DURING THE PROBLEM SOLVING PROCESS CAN CAUSE PERSONAL INJURY AND/OR DEATH. AVOID CONTACT WITH ANY VOLTAGE SOURCE WHILE PROBLEM SOLVING.



WARNING

ONLY PROPERLY TRAINED PERSONNEL FAMILIAR WITH THE TRANSFER SWITCH EQUIPMENT AND ITS ASSOCIATED EQUIPMENT SHOULD BE PERMITTED TO PERFORM THE PROBLEM SOLVING FUNCTION. IF AN INDIVIDUAL DOES NOT FEEL QUALIFIED TO PERFORM THE PROBLEM SOLVING FUNCTION, THE INDIVIDUAL SHOULD NOT ATTEMPT TO PERFORM ANY OF THESE PROCEDURES.

A basic problem solving effort is the first step to take prior to calling for assistance. Frequently, the effort will successfully address most problems encountered. Most problem solving procedures are outlined in the instruction manual unique to the type of logic being used. In addition, several problem solving procedures are presented here which are specific to the type of switches or circuit breakers used in this equipment.

If a problem persists after having completed the problem solving procedure, contact a Cutler-Hammer representative for further assistance. When calling for assistance, the following is the minimum information required to properly address the need:

1. Shop Order Number (SO#) or General Order Number (GO#) of transfer switch, plus related Item Number
2. Catalog and/or Style Number of transfer switch
3. Actual location of transfer switch (type of facility, address, etc.)
4. Company name
5. Name and position of individual representing company
6. Basic description of situation as it exists
7. Any results of problem solving steps taken and/or readings taken

6.2.1 TRANSFER SWITCH APPEARS INOPERATIVE

Step 1: Verify that all plugs and sockets are properly interconnected.

Step 2: Verify that the correct system voltage appears at NORMAL switch. Measure the voltage at the breaker lugs.

Step 3: Verify that the voltage selection plug is in the proper position to match the system voltage.

Step 4: Look for any obviously overheated components. Determine the cause and rectify, if possible. Replace defective components after the cause is determined.

Step 5: Manually ratchet the mechanism to the NORMAL position. Verify whether or not the system voltage now appears on the load terminals.

If YES: Proceed to check logic for problems in respective logic instruction book.

If NO: Check all power connections and the switching mechanism.

SECTION 7: MAINTENANCE

7.1 INTRODUCTION



WARNING

HIGH VOLTAGES ARE PRESENT IN AND AROUND TRANSFER SWITCH EQUIPMENT. BEFORE INSPECTING OR MAINTAINING THIS EQUIPMENT, DISCONNECT LINE POWER FROM THE EQUIPMENT BEING SERVICED BY OPENING AND LOCKING OUT, IF POSSIBLE, THE NEXT HIGHEST DISCONNECT DEVICE. FAILURE TO FOLLOW THIS PROCEDURE COULD CAUSE PERSONAL INJURY AND/OR DEATH.

In general, transfer switch equipment is designed to be relatively maintenance free under normal usage. However, because of the variability of application conditions

and the importance placed on dependable operation by this type of equipment, inspection and maintenance checks should be made on a regularly scheduled basis. Since equipment maintenance will consist mainly of keeping the equipment clean, the frequency of maintenance will depend, to a large extent, on the cleanliness of the surroundings. If a significant amount of dust or foreign matter is present, a more frequent maintenance schedule should be followed.

It is suggested that visual inspections of the equipment be made on a regular basis, not just during regularly scheduled periods. Always be alert for an accumulation of dirt in and around the structure, loose parts and/or hardware, cracks and/or discoloration to insulation, and damaged or discolored components.

7-2 PROCEDURES

A suggested maintenance procedure to follow is outlined in Table 7.1.

Table 7.1 Periodic Maintenance Procedures

Step	Action
a. Make transfer switch equipment safe for inspection and/or maintenance.	Disconnect line power from equipment being serviced by opening next highest disconnect device. Make certain that any accessory control power is switched off by disconnecting all logic plugs.
b. Inspect structure area for safety hazards or potential maintenance problems.	<p>Inspect area, especially where molded case switching devices are installed, for any safety hazards, including personnel safety and fire hazards. Exposure to certain chemical vapors can cause deterioration of electrical connections.</p> <p>Inspect for accumulated dirt, loose hardware or physical damage.</p> <p>Examine primary insulation for evidence of cracking or overheating. Overheating will show as discoloration, melting, or blistering of conductor insulation, or as pitting or melting of conductor surfaces due to arcing.</p> <p>Inspect secondary control connections for damage, and control wiring for insulation integrity.</p>
c. Inspect molded case switching devices for dust, dirt, soot, grease, moisture or corrosion.	Remove dust, dirt, soot, grease, moisture and corrosion contamination from the surface of the switching device using a dry soft lint-free cloth, dry soft bristle brush and vacuum cleaner. Do not blow debris into circuit breaker or nearby breaker structure. If contamination is found, look for the source and fix the problem.
d. Check for material integrity, uneven wear, discoloration or loose hardware.	Severe material cracking will require replacement and loose hardware will need to be tightened.
e. Check terminals and connectors for looseness or signs of overheating.	<p>Overheating will show as discoloration, melting, or blistering of conductor insulation.</p> <p>Connections that do not have signs of looseness or overheating should not be disturbed.</p>
f. Exercise the molded case switching devices if they are not often exercised while in operation. This will permit wiping action by the contacts.	If a switching device is used for frequent switching during normal operation, this step can be disregarded.
g. Return transfer switch equipment to service.	Make certain all barriers are in place and doors closed. Re-apply secondary and primary power.

This instruction booklet is published solely for information purposes and should not be considered all inclusive. If further information is required, you should consult Cutler-Hammer.

Sale of product shown in this literature is subject to terms and conditions outlined in appropriate Cutler-Hammer selling policies or other contractual agreement between the parties. This literature is not intended to and does not enlarge or add to any such contract. The sole source governing the rights and remedies of any purchaser of this equipment is the contract between the purchaser and Cutler-Hammer.

NO WARRANTIES, EXPRESSED OR IMPLIED, INCLUDING WARRANTIES OF FITNESS FOR A PARTICULAR PURPOSE OR MERCHANTABILITY, OR WARRANTIES ARISING FROM COURSE OF DEALING OR USAGE OF TRADE, ARE MADE REGARDING THE INFORMATION, RECOMMENDATIONS AND DESCRIPTIONS CONTAINED HEREIN. In no event will Cutler-Hammer be responsible to the purchaser or user in contract, in tort (including negligence), strict liability or otherwise for any special, indirect, incidental or consequential damage or loss whatsoever, including but not limited to damage or loss of use of equipment, plant or power system, cost of capital, loss of power, additional expenses in the use of existing power facilities, or claims against the purchaser or user by its customers resulting from the use of the information, recommendations and description contained herein.

Cutler-Hammer

Five Parkway Center
Pittsburgh, PA 15220