

Cutler-Hammer  
Beaver, PA

Automatic Transfer Switch

GENSWITCH  
Type ATVM/ATHM Wiring Diagrams



**Cutler-Hammer**



Copyright 1995,1996 by Eaton/Cutler Hammer Inc.  
All rights reserved

8155A99	Revision 4	Page 1 of 13	Engineer: J.R.Farls
ATVM	Wiring Diagram Book		Date: 09/10/98

Plug - Pin assignments for the GENSWITCH Transfer Switch.

P1 - Switching Panel

S1 - Transformer Panel

1	Normal	N1	Phase A
2	Normal	N2	Phase B
3	Normal	N3	Phase C
4	Normal	N1	Phase A
5	Normal	N2	Phase B
6	Normal	N3	Phase C
7	N Aux Sw #1	N.O.	
8	N Aux Sw #1	C	Limit Switch
9	N Aux Sw #1	N.C.	
10	N Aux Sw #2	N.O.	
11	N Aux Sw #2	C	
12	N Aux Sw #2	N.C.	
13	N Aux Sw #3	N.O.	
14	N Aux Sw #3	C	
15	N Aux Sw #3	N.C.	

P2 - Switching Panel

S2 - Transformer Panel

1	Emergency	E3	Phase C
2	Emergency	E2	Phase B
3	Emergency	E1	Phase A
4	Emergency	E3	Phase C
5	Emergency	E2	Phase B
6	Emergency	E1	Phase A
7	E Aux Sw #1	N.O.	
8	E Aux Sw #1	C	Limit Switch
9	E Aux Sw #1	N.C.	
10	E Aux Sw #2	N.O.	
11	E Aux Sw #2	C	
12	E Aux Sw #2	N.C.	
13	E Aux Sw #3	N.O.	
14	E Aux Sw #3	C	
15	E Aux Sw #3	N.C.	

8155A99	Revision 4	Page 2 of 13	Engineer: J.R.Farls
ATVM	Wiring Diagram Book		Date: 09/10/98

P3 - Switching Panel to  
S3 - Transformer Panel

1		
2		
3		
4	Motor	Bridge "AC" In
5	Motor	Bridge "AC" In
6		
7		
8		
9		
10		
11		
12		

P4 - Transformer Panel to  
S4 - Intelligence Panel

1	Motherboard 1
2	Motherboard 2
3	Motherboard 3
4	Motherboard 4
5	Motherboard 5
6	Motherboard 6
7	Motherboard 7
8	Motherboard 8
9	Motherboard 9
10	Motherboard 10
11	Reserved
12	Reserved
13	Reserved
14	Reserved
15	

S5 - Transformer Panel to  
P5 - Intelligence Panel (Door)

- 1 Normal from NLS
- 2 Emergency from ELS
- 3 Control Neutral
- 4 Normal Control Power
- 5 Emergency Control Power
- 6 Normal Position Light
- 7 Emergency Position Light
- 8 Normal Logic Interrupt (Test Pushbutton)
- 9 Normal Logic Interrupt (Test Pushbutton)
- 10 Emergency Logic Interrupt
- 11 Emergency Logic Interrupt
- 12 Transfer Motor Operate
- 13 NRA Relay Power
- 14 Engine Start Circuit Source 2
- 15 Engine Start Circuit Source 2

S7a - g Voltage Selector - Socket  
P7 - Plug

- 1 NT3
- 2 NT4
- 3 NT1
- 4 ET1
- 5 ET4
- 6 ET3

8155A99	Revision 4	Page 4 of 13	Engineer: J.R.Farls
ATVM	Wiring Diagram Book		Date: 09/10/98

# Cutler-Hammer Automatic Transfer Switch Wiring Diagrams

## Directions for Use

The drawing package can be used as a point to point wiring diagram for maintenance and diagnostic purposes for the GENSWITCH (Catalog ATVM) Transfer Switches, 30 - 1000 Ampere, all voltages.

This document contains the following wiring information:

- Basic Switching Panel Wiring
- Basic wiring diagrams for the transformer and intelligence panels.
- Wiring for all normally available features. (Options)
- Legend Sheet describing symbols used throughout this document.

<b>8155A99</b>	Revision 4	Page 5 of 13	Engineer: J.R.Farls
<b>ATVM</b>	<b>Wiring Diagram Book</b>		Date: 09/10/98

## Legend Sheet

BR	Bridge Rectifier
EL	Emergency Position Indicator Light
ER	Emergency Relay
ERA	Emergency Auxiliary Relay
ERB	Emergency Auxiliary Relay
ETx	Emergency Transformer
Ex	Emergency Power Terminal x
KB	Brake Relay
KF	Failsafe Relay
NL	Normal Position Indicator Light
NR	Normal Relay
NRA	Normal Auxiliary Relay
NRB	Normal Auxiliary Relay
NTx	Normal Transformer x
Nx	Normal Power Terminal x
PE	Plant Exerciser Clock
PSDR	Pretransfer Signal Relay
PSDT	Pretransfer Signal Timer
Px-y	"Plug Number x, Pin Number y"
Sx-y	"Socket Number x, Pin Number y"
TDEC	Time Delay Engine Cooloff
TDEN	Time Delay Emergency to Normal
TDES	Time Delay Engine Start
TDN	Time Delay Neutral
TDNE	Time Delay Normal to Emergency

<b>8155A99</b>	Revision 4	Page 6 of 13	Engineer: J.R.Farls
<b>ATVM</b>	<b>Wiring Diagram Book</b>		Date: 09/10/98

# 100 Amp Switching Panel Assembly

GENSWITCH (Cat. No. ATVM ONLY)

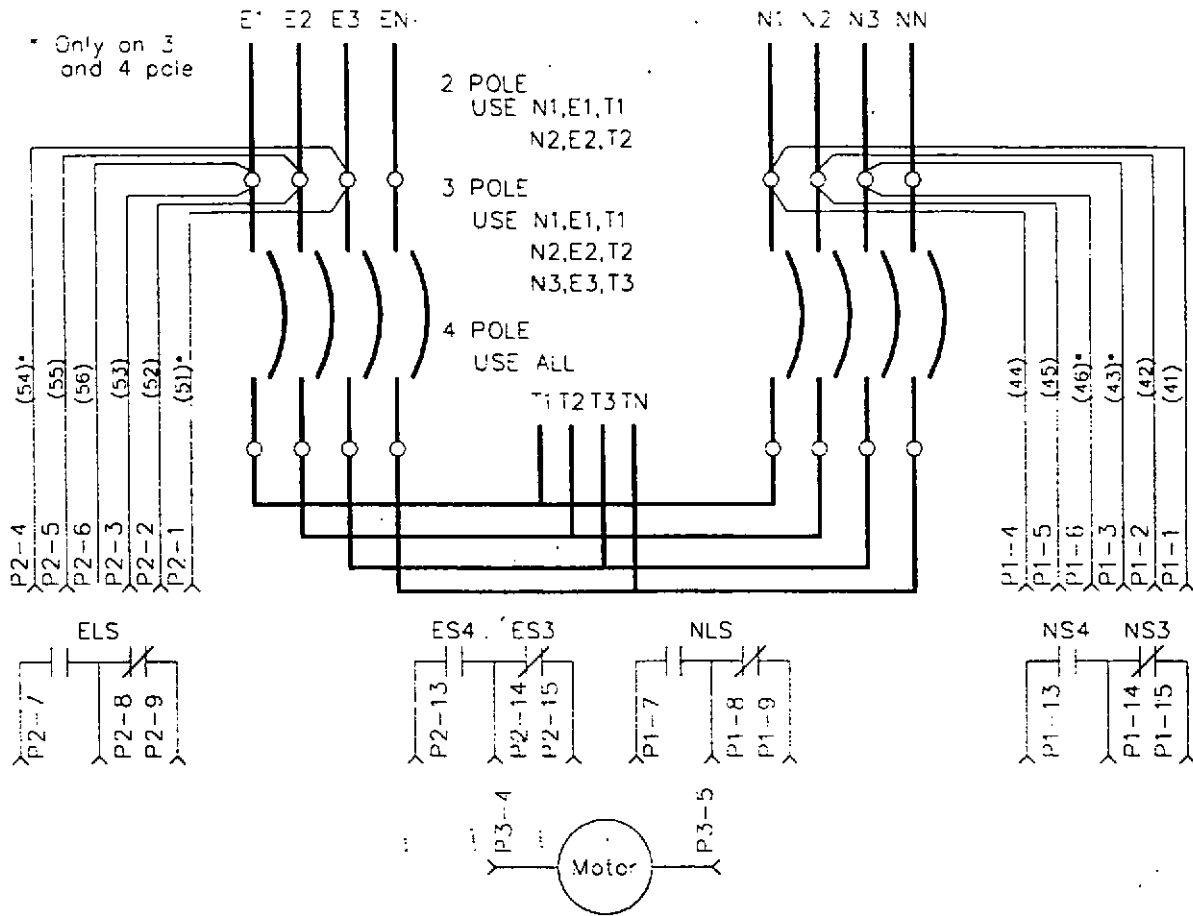

NLS and ELS are located on the mechanism

NS3/NS4 and ES3/ES4 are ONLY supplied when Option 32 is supplied

NS3/NS4 and ES3/ES4 are mounted internally in the switching devices

<b>8155A99</b>	Revision 4	Page 7 of 13	Engineer: J.R.Farls
<b>ATVM</b>	<b>Wiring Diagram Book</b>		Date: 09/10/98

# Switching Pane (150 - 1000 Ampere, 2,3,or 4 pole)

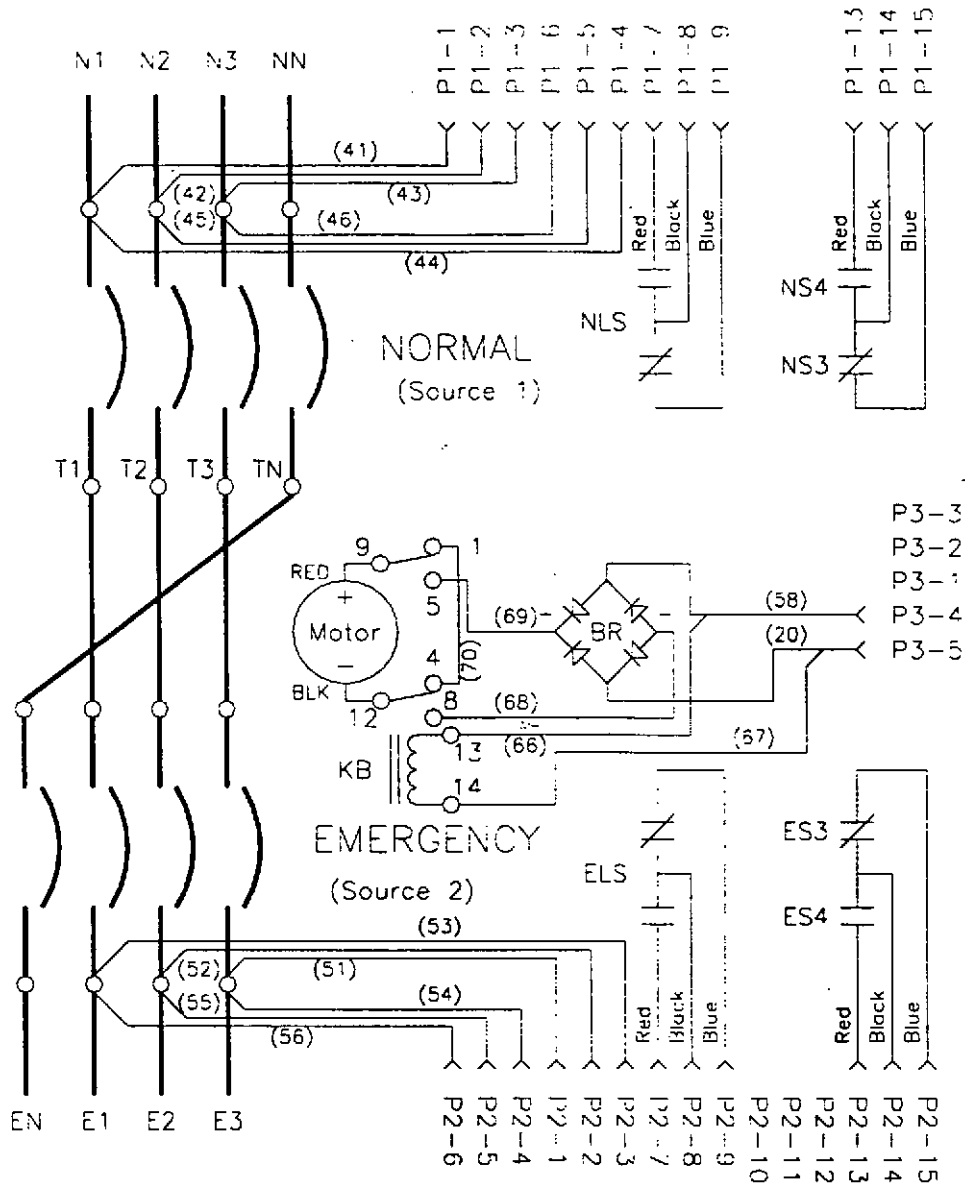

NLS/NS3/NS4 and ELS/ES3/ES4 are mounted internally in the switching devices  
 NS3/NS4 and ES3/ES4 are ONLY supplied when Option 32 is supplied

<b>8155A99</b>	Revision 4	Page 8 of 13	Engineer: J.R.Farls
<b>ATVM</b>	<b>Wiring Diagram Book</b>		Date: 09/10/98

# Transformer Panel

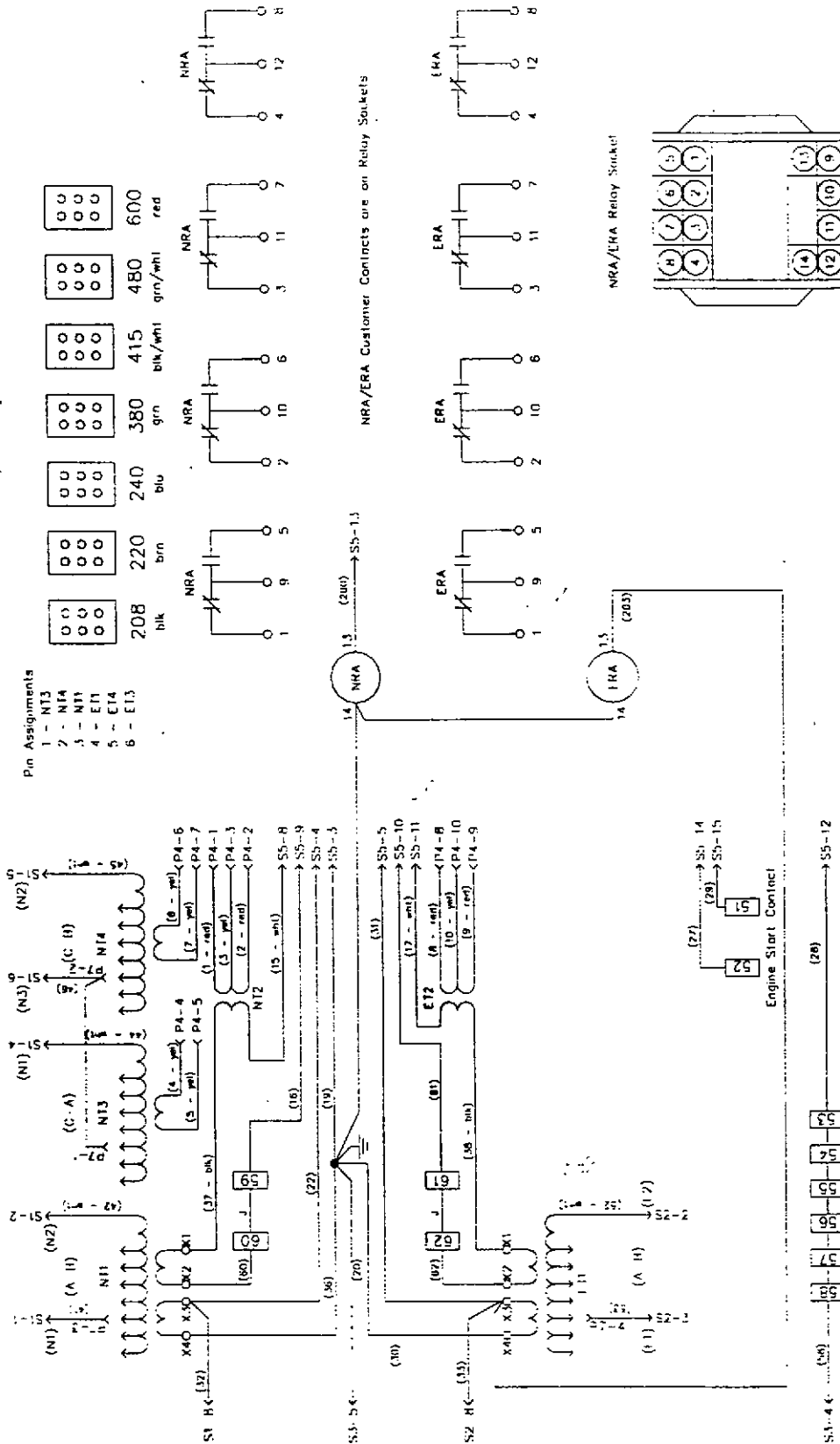

<b>8155A99</b>	Revision 4	Page 9 of 13	Engineer: J.R.Farls
<b>ATVM</b>	<b>Wiring Diagram Book</b>		Date: 09/10/98

Intelligence Panel  
Single Board Controller

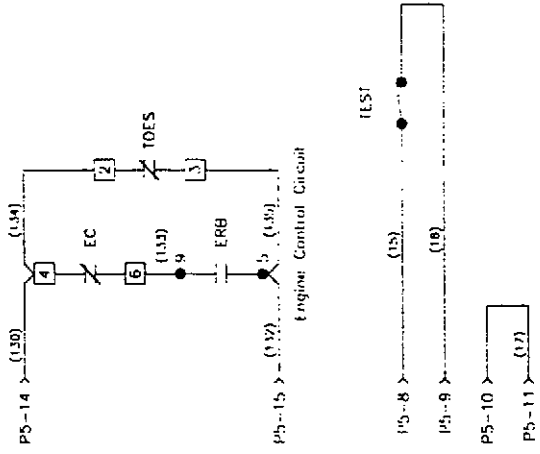
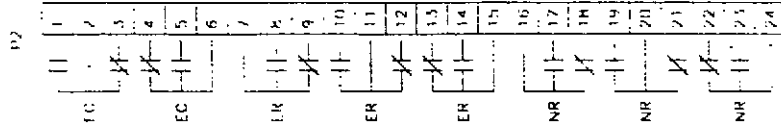
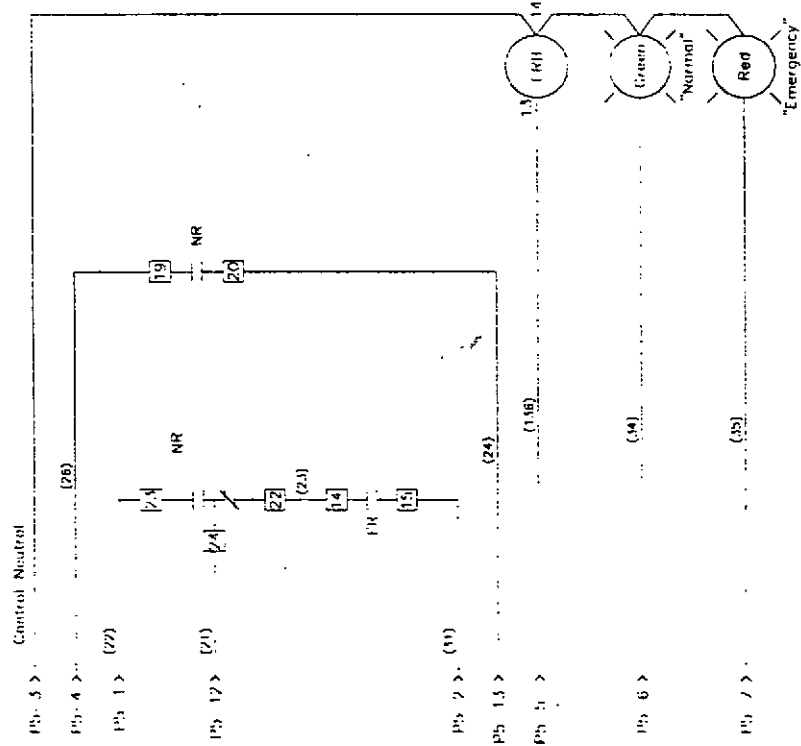
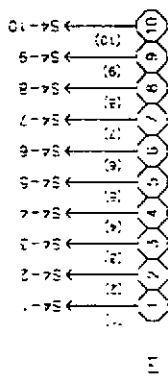

**Intelligence Panel**  
Single Board Controller w/Opt/IG

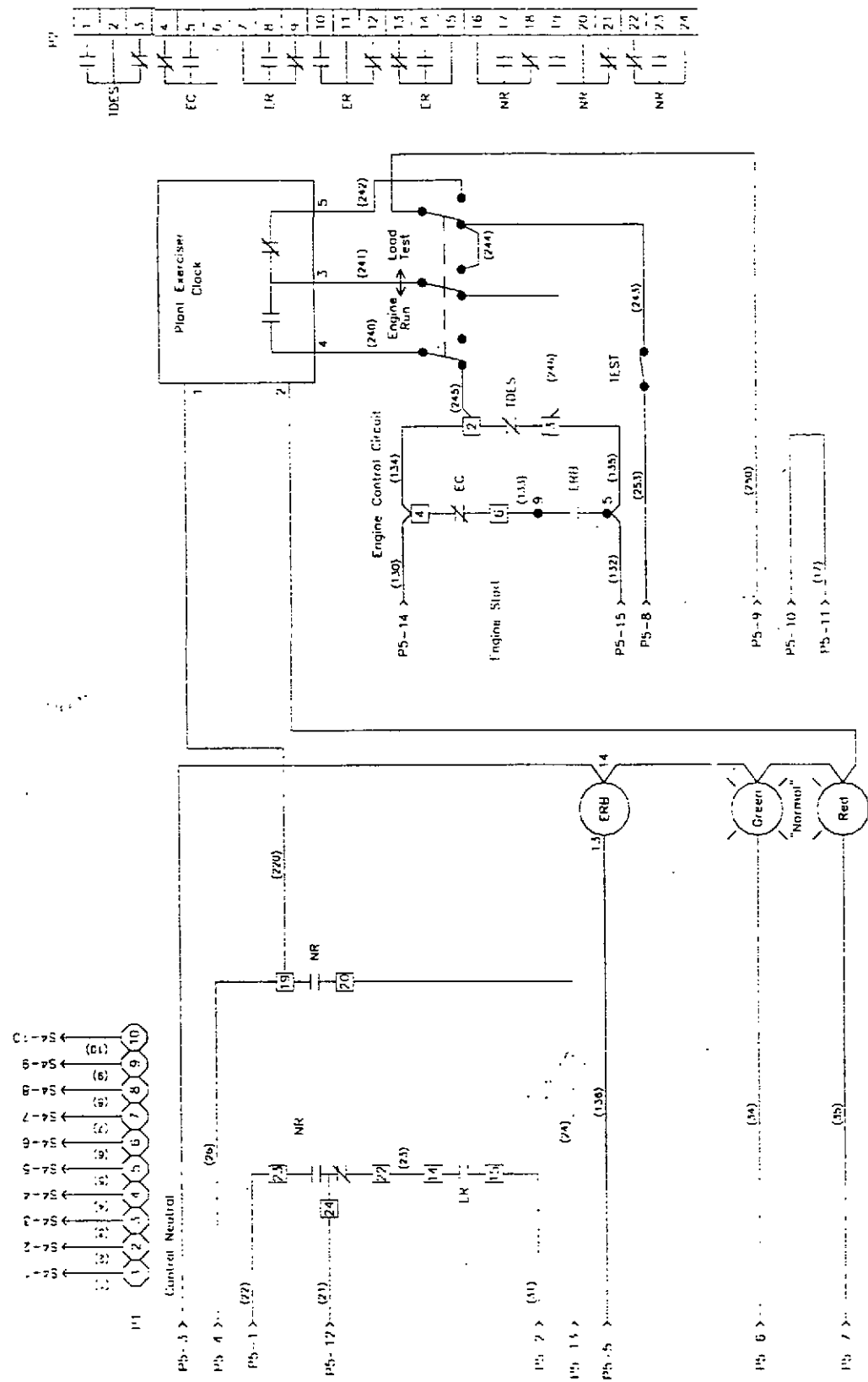

Single Bond Controller w/Opt2.5J

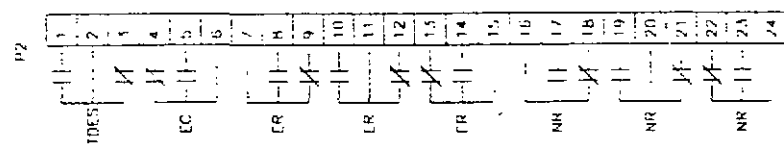
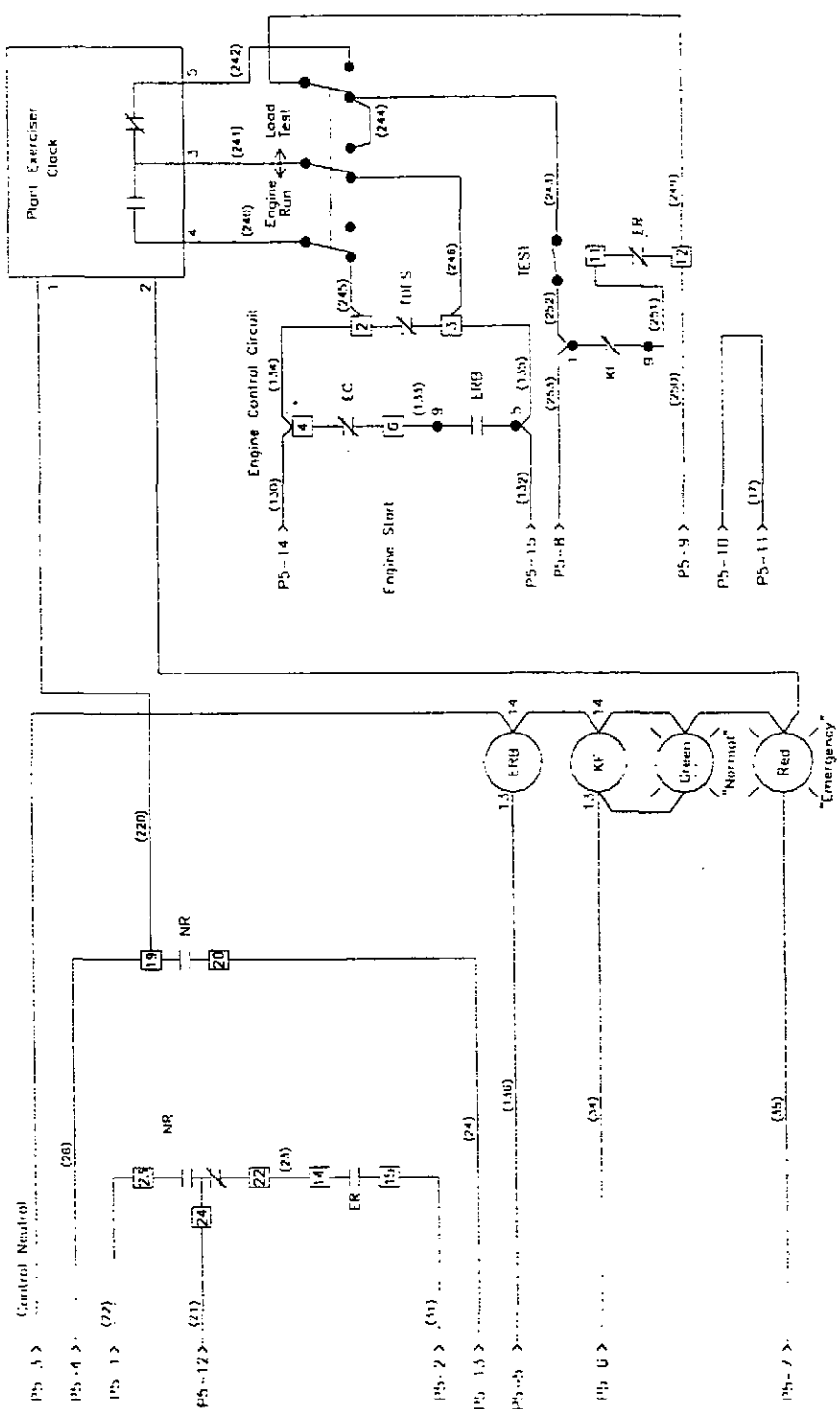
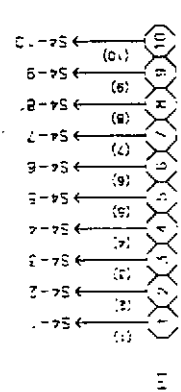

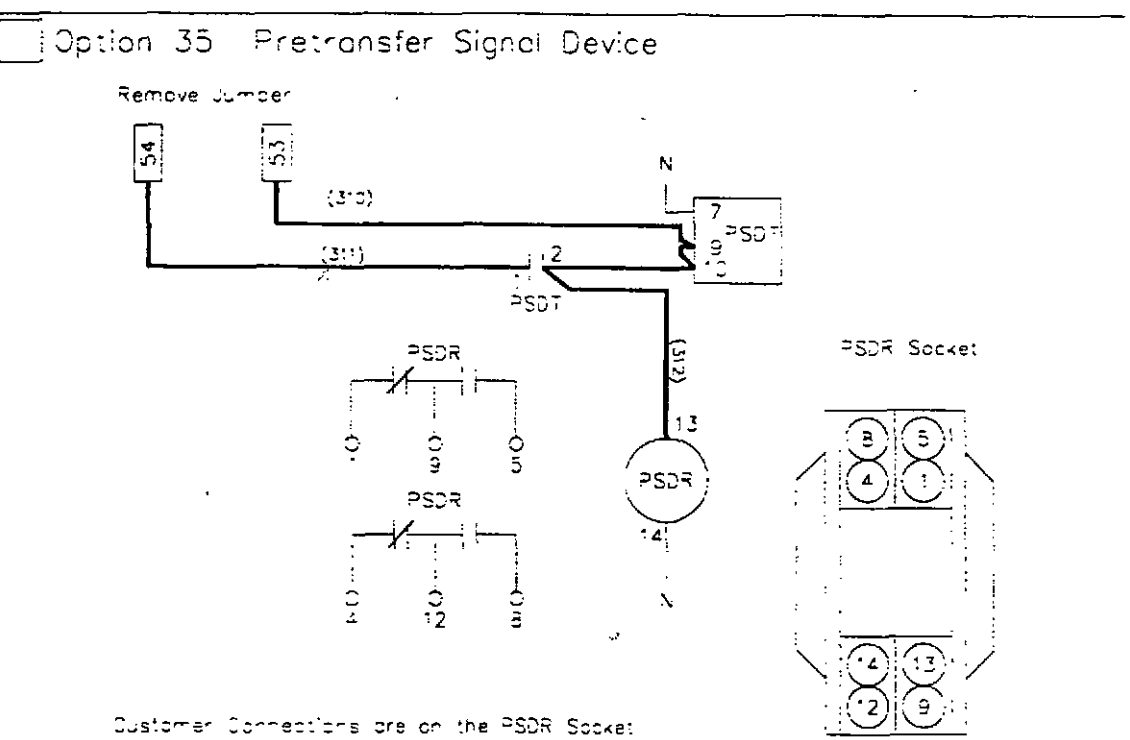
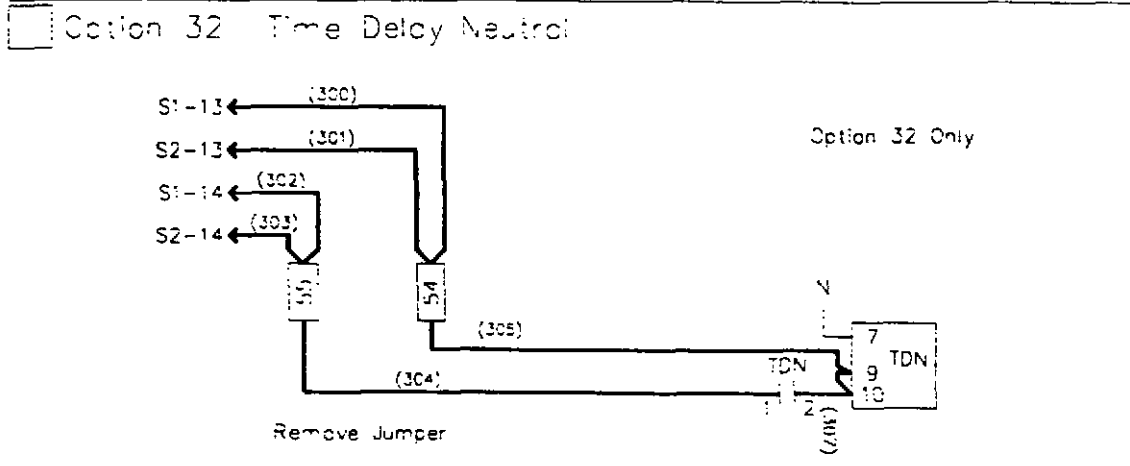
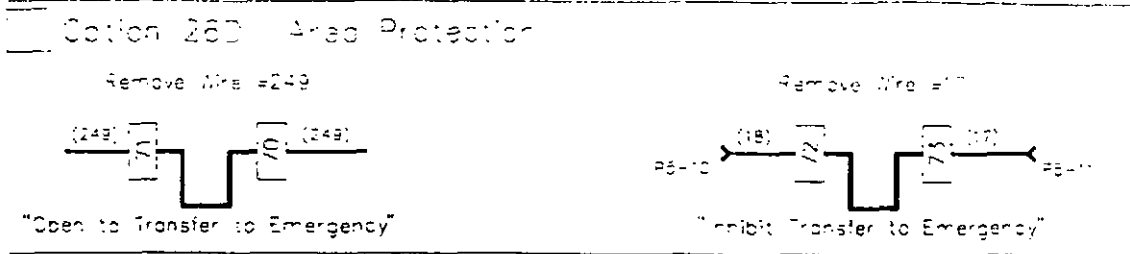

Cutler-Hammer  
Beaver, PA

Automatic Transfer Switch

AGswitch  
Wiring Diagrams



**Cutler-Hammer**

---

**EATON**

Copyright 1997 by Eaton/Cutler Hammer Inc.  
All rights reserved

8165A13	Revision 5	Page 1 of 6	Engineer: J.R.Farls
AGswitch	Wiring Diagram Book		Date: 9/30/98

Plug - Pin assignments for the GENSWITCH Transfer Switch.

P1 - Switching Panel

S1 - Logic Panel

1	Normal	N1	Phase A
2	Normal	N2	Phase B
3	Normal	N3	Phase C
4	Normal	N1	Phase A
5	Normal	N2	Phase B
6	Normal	N3	Phase C
7	N Aux Sw #1	N.O.	
8	N Aux Sw #1	C	Limit Switch
9	N Aux Sw #1	N.C.	
10	N Aux Sw #2	N.O.	
11	N Aux Sw #2	C	
12	N Aux Sw #2	N.C.	
13	N Aux Sw #3	N.O.	
14	N Aux Sw #3	C	
15	N Aux Sw #3	N.C.	

P2 - Switching Panel

S2 - Logic Panel

1	Emergency	E3	Phase C
2	Emergency	E2	Phase B
3	Emergency	E1	Phase A
4	Emergency	E3	Phase C
5	Emergency	E2	Phase B
6	Emergency	E1	Phase A
7	E Aux Sw #1	N.O.	
8	E Aux Sw #1	C	Limit Switch
9	E Aux Sw #1	N.C.	
10	E Aux Sw #2	N.O.	
11	E Aux Sw #2	C	
12	E Aux Sw #2	N.C.	
13	E Aux Sw #3	N.O.	
14	E Aux Sw #3	C	
15	E Aux Sw #3	N.C.	

P3 - Switching Panel to  
S3 - Transformer Panel

- 1
- 2
- 3
- 4 Motor Bridge "AC" In
- 5 Motor Bridge "AC" In
- 6
- 7
- 8 Bell Alarm - Normal
- 9 Bell Alarm - Normal
- 10
- 11 Bell Alarm - Emergency
- 12 Bell Alarm - Emergency

S6 - Device Panel  
P6 - Logic Panel

- 1 Service Entrance Switch
- 2 Service Entrance Switch
- 3 Service Entrance Switch
- 4 Service Entrance Indicator
- 5 Service Entrance Switch
- 6 Service Entrance Switch

8165A13	Revision 5	Page 3 of 6	Engineer: J.R.Farls
AGswitch	Wiring Diagram Book		Date: 9/30/98

# Cutler-Hammer Automatic Transfer Switch Wiring Diagrams

## Directions for Use

The drawing package can be used as a point to point wiring diagram for maintenance and diagnostic purposes for the AGswitch Transfer Switches, all voltages.

This document contains the following wiring information:

- Basic wiring diagram.
- Legend Sheet describing symbols used though out this document.

8165A13	Revision 5	Page 4 of 6	Engineer: J.R.Farls
AGswitch	<b>Wiring Diagram Book</b>		Date: 9/30/98

## Legend Sheet

AMBER	S.E. Indicator - Illuminates when SDSS is in "De-Energize"
ER	Emergency Relay - Energized when Emer. is Available
ERA	Emergency Auxiliary Relay - Energized when Emer. is Available
ERB	Emergency Auxiliary Relay - Energized when Emer. is Available
ETx	Emergency Transformer - Control Power for Microprocessor
KF	Fail-safe Relay - Energized when in Normal Position
GREEN	Normal Indicator - Illuminates when in Normal Position
NR	Normal Relay - Energized when Normal is Available
NRA	Normal Auxiliary Relay - Energized when Normal is Available and in Normal Position
NTx	Normal Transformer - Control Power for Microprocessor
PE	Plant Exerciser Clock - Weekly Transfer Exerciser Clock
PESS	Plant Exerciser Selector Switch "Engine Run" - When Exercised, only the Generator will Start "Load Test" - When Exercised the ATS will Transfer the Load
Px-y	"Plug Number x, Pin Number y"
RED	Emergency Indicator - Illuminates when in Emergency Position
Sx-y	"Socket Number x, Pin Number y"
SDSSx	Service Entrance Selector Switch "Energize" - ATS Normal Position "De-Energize" - Transfers to 'NEUTRAL' position (Key is Removable) until Returned to Energize
TDEC	Time Delay Engine Cooloff
TDEN	Time Delay Emergency to Normal
TDES	Time Delay Engine Start
TDN	Time Delay Neutral
TDNE	Time Delay Normal to Emergency
TEST	Auto/Test Selector Switch "Auto" - ATS Normal Operation "Test" - ATS will Transfer Load until Returned to "Auto"

8165A13	Revision 5	Page 5 of 6	Engineer: J.R.Farls
AGswitch	Wiring Diagram Book		Date: 9/30/98

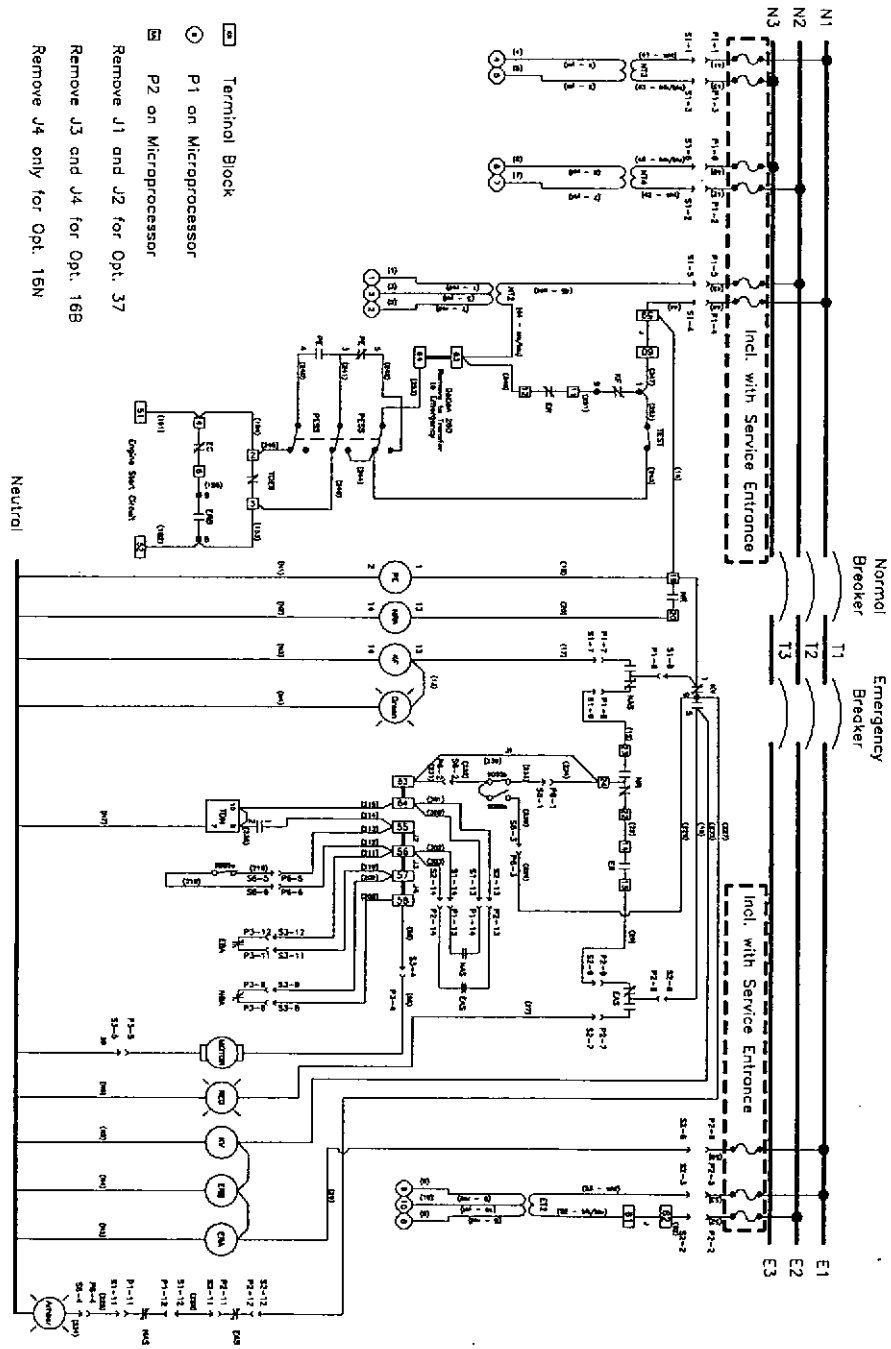

- ☐ Terminal Block
- P1 on Microprocessor
- P2 on Microprocessor
- Remove J1 and J2 for Opt. 37
- Remove J3 and J4 for Opt. 16B
- Remove J4 only for Opt. 16N

1	<i>ATSBP</i>
2	<i>ATSBM</i>
3	<i>ATSRM</i>
4	<i>ATSRD</i>
5	<i>ATSBI / (SPB)ATSBI</i>
6	<i>MTSRM</i>
7	<i>MTSBM</i>
8	<i>ATSBR</i>
9	<i>ATVS / ATHSFD</i>
10	<i>ATVM</i>
11	<i>ATVE</i>
12	<i>ATVSSP</i>
13	<i>NTVS</i>
14	<i>NTVSSP</i>
15	<i>BIHS</i>

AUTOMATIC TRANSFER SWITCH  
WIRING DIAGRAMS

Catalog Number **ATSBF** Only  
Transfer Switch

Shop Order:

Westinghouse Electric Corporation  
Electrical Components Division  
250 Westinghouse Drive  
London, KY 40741

(C) Copyright 1990, 1991 by Westinghouse Electric Corporation  
All Rights Reserved

ATSBP-WD V2.1 7-9-91

WESTINGHOUSE AUTOMATIC TRANSFER SWITCH  
WIRING DIAGRAMS

DIRECTIONS FOR USE

The drawing package can be used as a point to point wiring diagram for maintenance and diagnostic purposes for Electromechanical Transfer Switches, 100 - 1000 Amperes.

This document contains the following wiring information:

Page 1	Basic Electromechanical Intelligence Panel wiring exclusive of added option functions
Page 2	Power Switching Panel basic wiring 100, 400, 600, 800, and 1000 amperes exclusive of added option functions
Page 3	Power Switching Panel basic wiring 150 - 280 amperes exclusive of added option functions
Pages 4 - 12	Wiring for optional functions
Page 13	Legend Sheet describing symbols used throughout this document

Note: Unnumbered sheets may be added to this document on specific occasions to illustrate custom options additions per order instructions.

All transfer switch units will be standardly wired as indicated by Pages 1, and Pages 2 or 3. The Intelligence Panel and Power Panel are interconnected via keyed plug/socket connectors (P1-S1/P2-S2). Your specific unit may be equipped with certain optional functions as noted which require additional wiring as shown on pages 4 - 12.

Wiring for optionally added functions will typically interface with the basic unit wiring (Pages 1 - 3) which should be used as the base reference.

Note: BOLD LINES on option wiring indicate components and wiring added to the basic wiring diagram to accomplish that specific option function.

# ELECTROMECHANICAL INTELLIGENCE PANEL

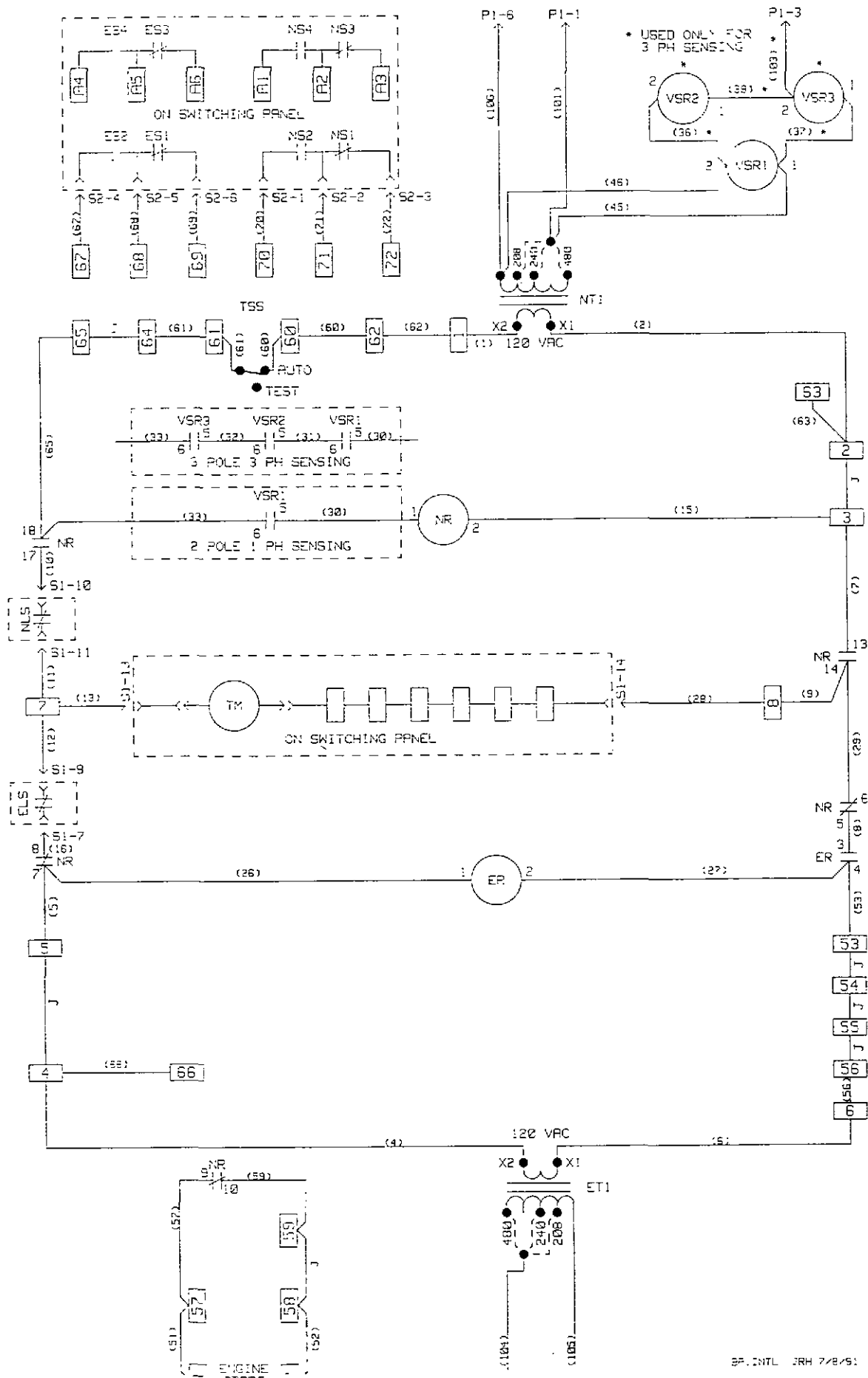

# POWER SWITCHING PANEL 150 - 300 AMPERE

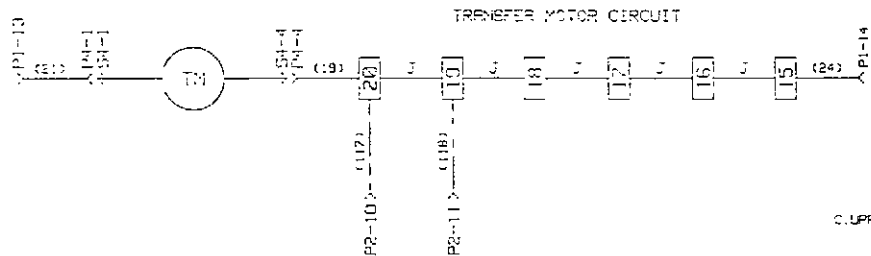
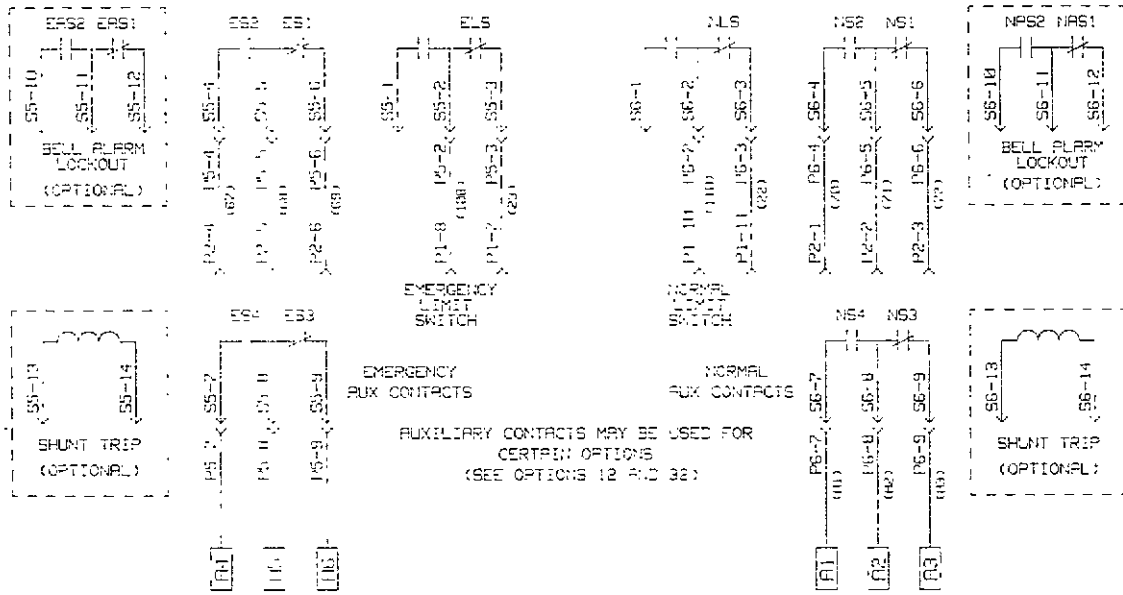
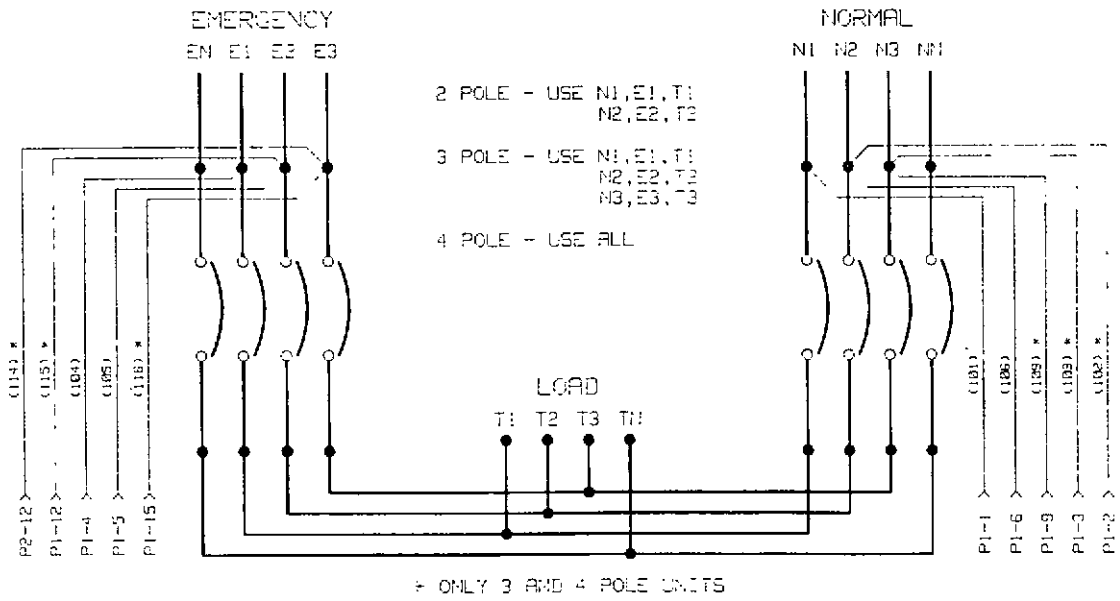



# POWER SWITCHING PANEL

## 100, 400, 600, 800, 1000 AMPERES

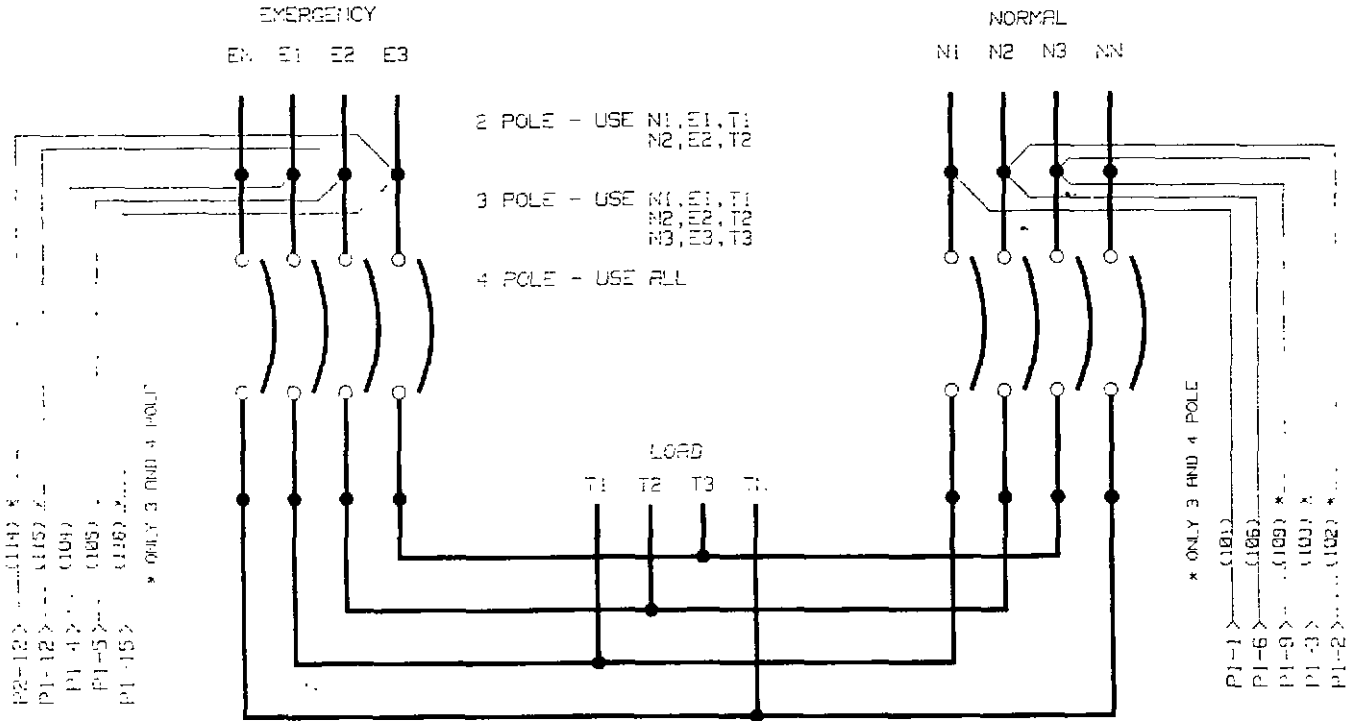

EMERGENCY SOURCE AUX. CONTACTS

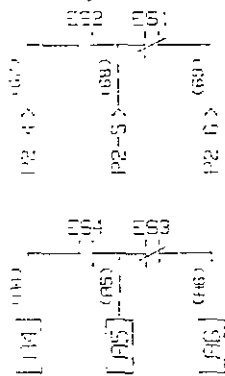

EMERGENCY LIMIT SWITCH

AUX CONTACTS MAY BE USED FOR CERTAIN OPTIONS (SEE OPTIONS 12 AND 32)

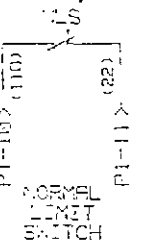

NORMAL LIMIT SWITCH

NORMAL SOURCE AUX. CONTACTS

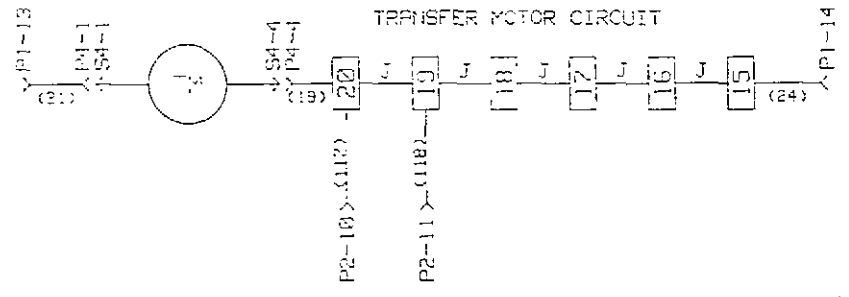
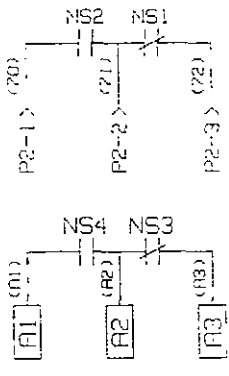



- OPTION 4 TIME DELAY ENGINE COOLDOWN (TDEC)  
PERMITS THE GENERATOR TO RUN UNDER  
A NO-LOAD CONDITION AFTER TRANSFER TO NORMAL

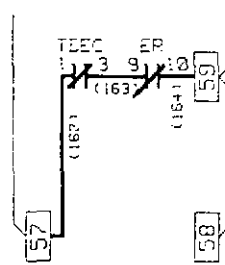
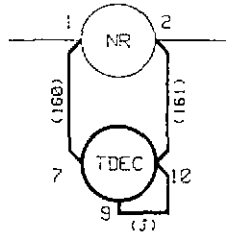

- OPTION 5B - EMERGENCY LV/UF SENSING (FR)  
PREVENTS TRANSFER TO EMERGENCY UNTIL  
PROPER VOLTAGE AND FREQUENCY ARE PRESENT

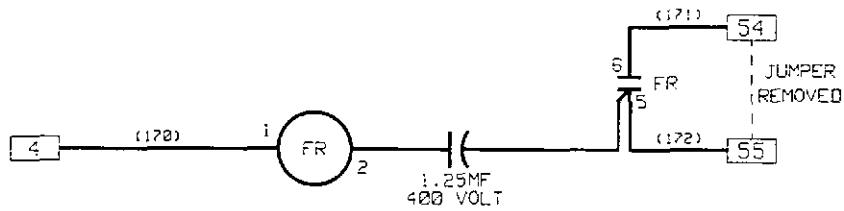

- OPTION 5B - TEST PUSHBUTTON

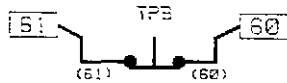

- OPTION 5H - FOUR POSITION SELECTOR SWITCH (FPSS)  
PERMIT FOUR MODES OF TRANSFER SWITCH OPERATION  
TEST - AUTO - OFF - ENGINE RUN

REPLACES TEST SWITCH

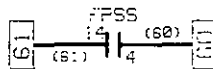

FPSS	9	11	4	15	17
TEST	X	X	X	X	X
AUTO	X	X	X	X	X
OFF	X	X	X	X	X
ENG. RUN	X	X	X	X	X

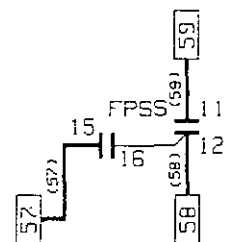
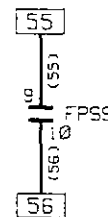
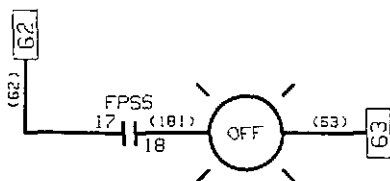

- OPTION 8C - BYPASS TDEN TIMER (PBEN)  
 PROVIDES A BYPASS OF TDEN TIMING TO EFFECT  
 AN IMMEDIATE TRANSFER TO NORMAL

NOTE: THIS OPTION ONLY AVAILABLE  
 WHEN OPTION 3 IS PROVIDED

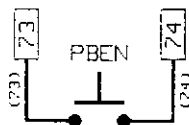

- OPTION 9 - MAINTENANCE SELECTOR SWITCH  
 PROVIDES A MOTOR CIRCUIT DISCONNECT TO  
 PREVENT TRANSFER DURING ATS MAINTENANCE

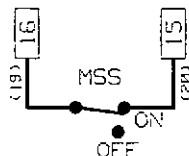

- OPTION 11D - PUSHBUTTON RESET NORMAL  
 PROVIDES PUSHBUTTON RESET OF LOCKOUT

NOTE: ONLY AVAILABLE IF OPTION 11F  
 IS PROVIDED

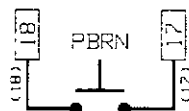

NOTE: NOT AVAILABLE ON 100 AMP

- OPTION 11E - PUSHBUTTON RESET EMERGENCY  
 PROVIDES PUSHBUTTON RESET OF LOCKOUT

NOTE: ONLY AVAILABLE IF OPTION 11F  
 IS PROVIDED



NOTE: NOT AVAILABLE ON 100 AMP

- OPTION 11F - TRIP LOCKOUT  
 PREVENTS TRANSFER AFTER BREAKER TRIP  
 DUE TO OVERLOAD CONDITION  
 (PROVIDED AS STANDARD WITH THERMAL  
 MAGNETIC TRIP UNITS)

NOTE: NOT USED ON 100 AMP

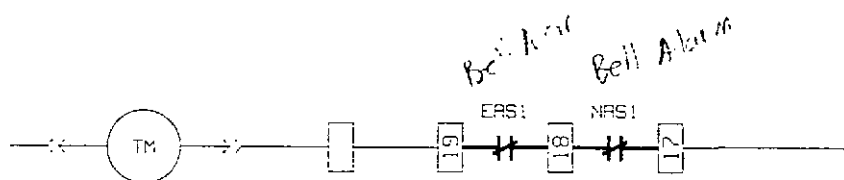

- OPTION 12C - NORMAL POSITION LIGHT  
INDICATES LOAD IS CONNECTED TO NORMAL

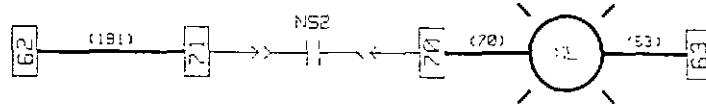

- OPTION 12D - EMERGENCY POSITION LIGHT  
INDICATES LOAD IS CONNECTED TO EMERGENCY

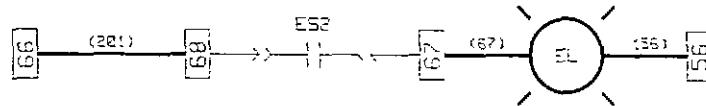

- OPTION 12G - NORMAL SOURCE LIGHT  
INDICATES NORMAL SOURCE AVAILABLE

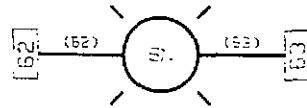

- OPTION 12H - EMERGENCY SOURCE LIGHT  
INDICATES EMERGENCY SOURCE AVAILABLE

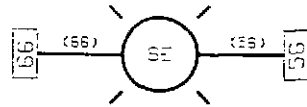

- OPTION 12L - NORMAL TRIPPED INDICATOR  
INDICATES OVERLOAD TRIP ON NORMAL

NOTE: ONLY AVAILABLE WHEN  
OPTION 11F IS SUPPLIED

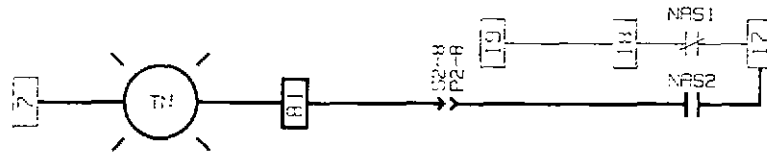

- OPTION 12M - EMERGENCY TRIPPED INDICATOR  
INDICATES OVERLOAD TRIP ON EMERGENCY

NOTE: ONLY AVAILABLE WHEN  
OPTION 11F IS SUPPLIED

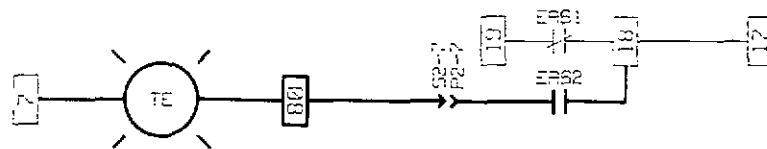



OPTION 14C - NORMAL AUXILIARY RELAY (NRA)  
 PROVIDES ADDITIONAL RELAY CONTACTS ON NORMAL

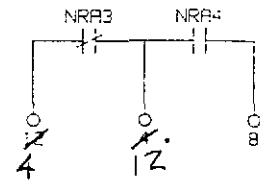
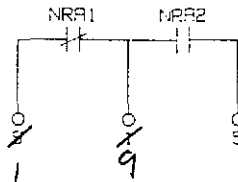
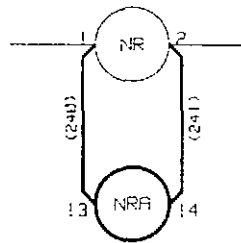

OPTION 14D - EMERGENCY AUXILIARY RELAY (ERA)  
 PROVIDES ADDITIONAL RELAY CONTACTS ON EMERGENCY

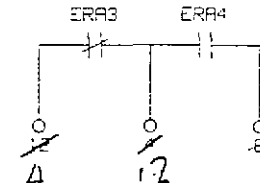
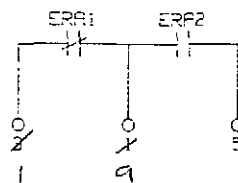
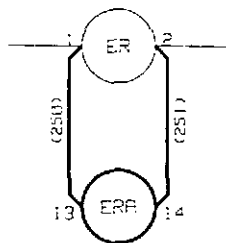

NRA - ERA SOCKET DIAGRAM

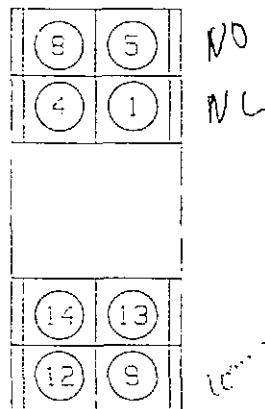

OPTION 18E - VOLTMETER

	HANDLE POSITION:					
	NORMAL			EMERGENCY		
	1-3	2-3	1-2	1-2	2-3	1-3
1 — 2				X	X	X
3 — 4	X		X			
5 — 6					X	X
7 — 8		X				
9 — 10						X
11 — 12	X					
13 — 14				X	X	X
15 — 16		X	X			

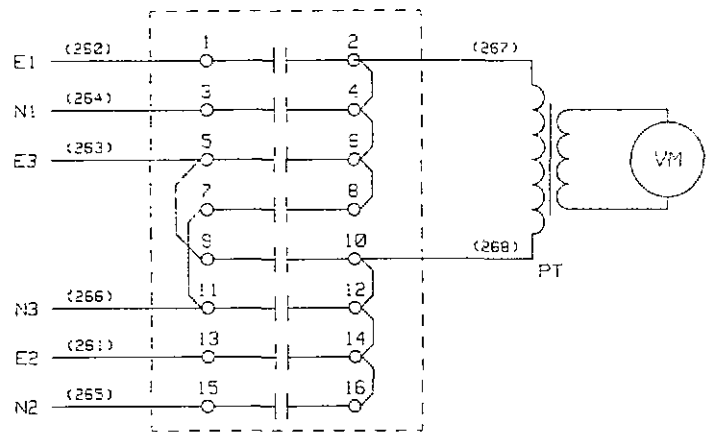

OPTION 18F - AMMETER

	HANDLE POSITION:						
	OFF	-	1	-	2	-	3
1 — 2	X	X	X	X	X	X	X
3 — 4	X	X	X	X	X	X	X
5 — 6	X	X	X	X	X	X	X
7 — 8	X	X	X	X	X	X	X
9 — 12	X	X	X	X	X	X	X
11 — 12	X	X	X	X	X	X	X

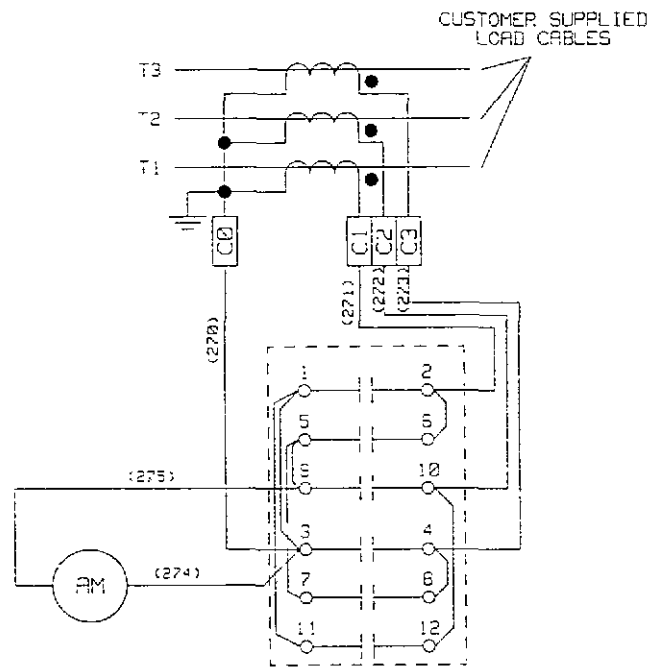

OPTION 18G - FREQUENCY METER

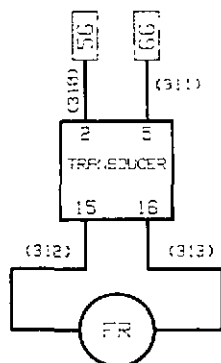

OPTION 18H - RUNNING TIME METER

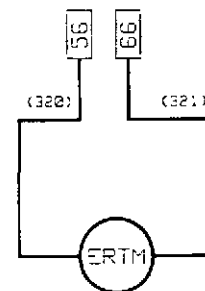

OPTION 23C - PLANT EXERCISER  
 RUN ENGINE AT SPECIFIED TIME - NO LOAD

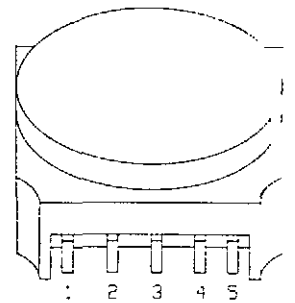

PLANT EXERCISER  
 TERMINAL LAYOUT

OPTION 23D - PLANT EXERCISER  
 RUN ENGINE AT SPECIFIED TIME - LOAD



OPTION 23G - PLANT EXERCISER  
 RUN ENGINE AT SPECIFIED TIME - LOAD OR NO LOAD  
 (SWITCH SELECTABLE)

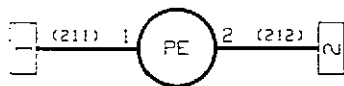

	ENGINE RUN	BYPASS	LOAD	TEST
1 - 2	X			
5 - 6			X	
7 - 8	X	X		
9 - 10	X			
11 - 12				X

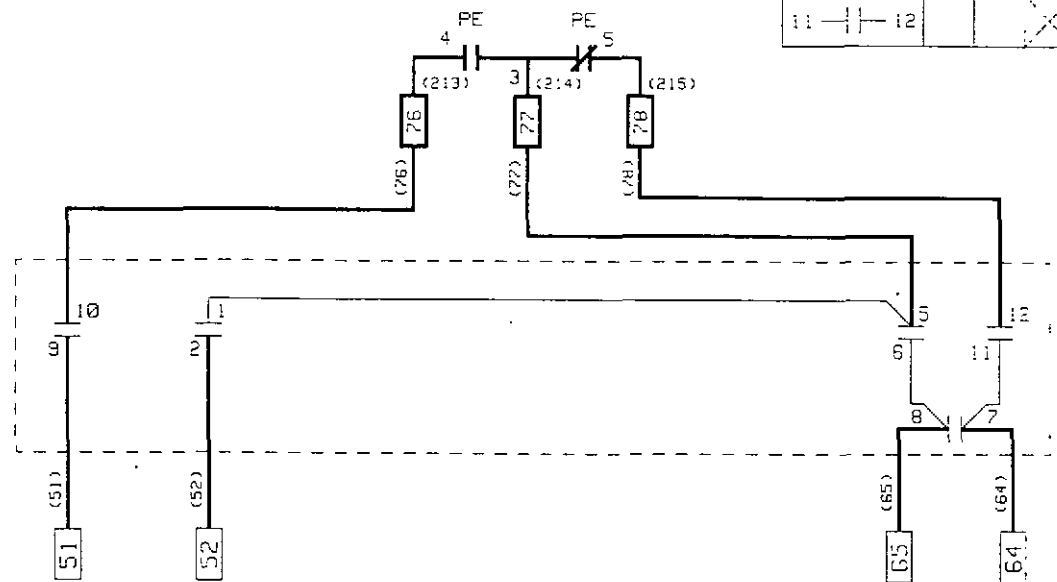

REMOVE JUMPER 54-55

OPTION 29 B/D - PUSHBUTTON (MANUAL) OPERATION

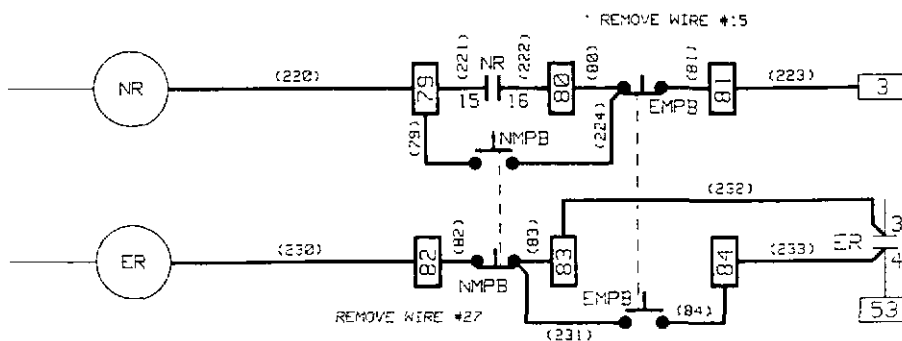

OPTION 29 C/E - MANUAL RETURN TO NORMAL

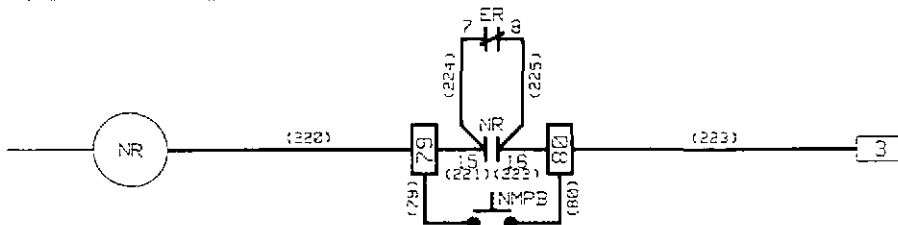

OPTION 29 F/G - AUTO/MANUAL OPERATION

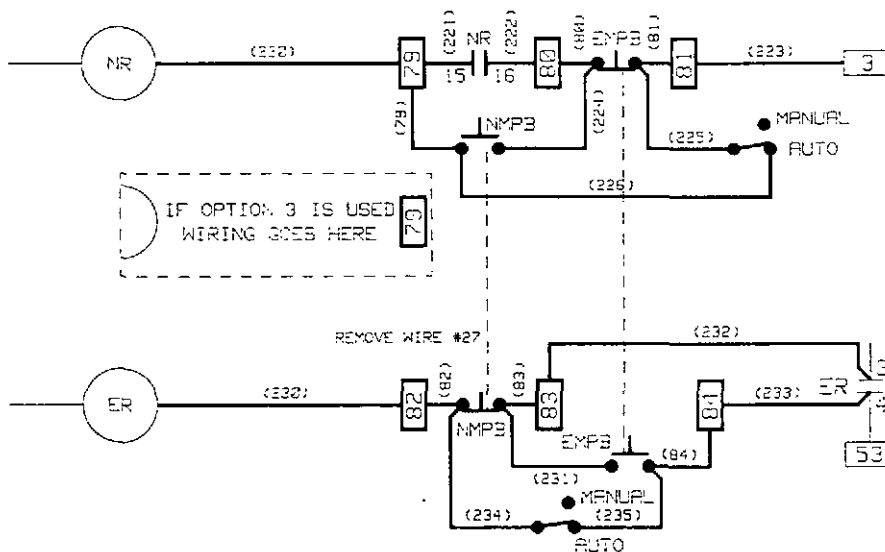

- OPTION 30 - TIME DELAY CRANK LIMITER (TDCL)  
 INTERRUPTS ENGINE START CIRCUIT IF VOLTAGE DOES NOT APPEAR WITHIN A PRESELECTED TIME

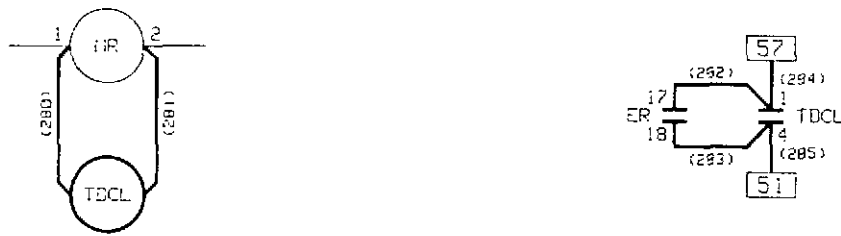

- OPTION 32 - TIME DELAY NEUTRAL (TDN)  
 PROVIDES A TIME DELAY IN THE NEUTRAL POSITION WHEN THE LOAD IS TRANSFERRED IN EITHER DIRECTION TO PREVENT EXCESSIVE INRUSH CURRENTS DUE TO OUT-OF-PHASE SWITCHING OF INDUCTIVE LOADS

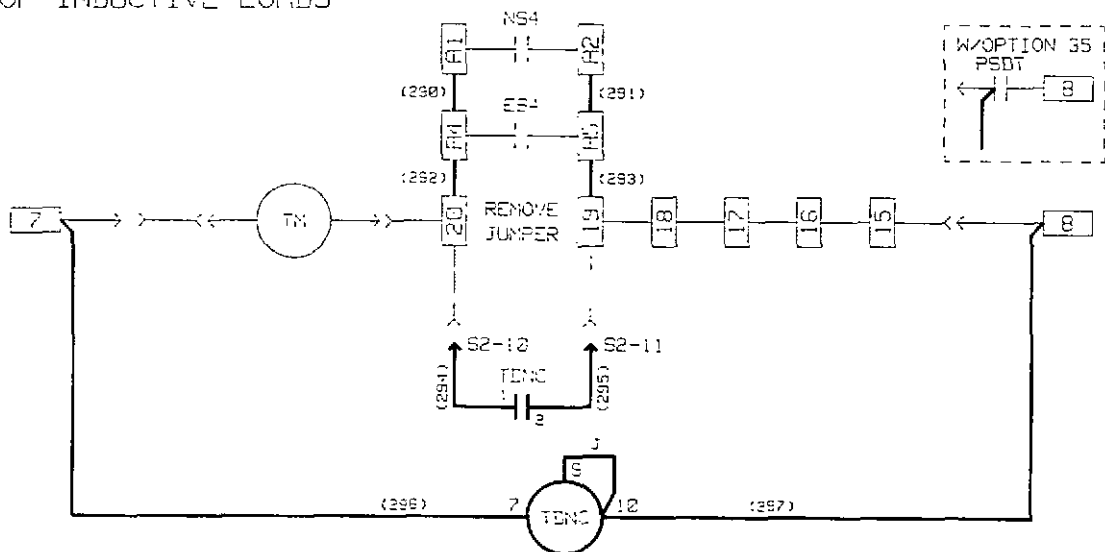

- OPTION 35 - PRETRANSFER SIGNAL DEVICE  
 RELAY CONTACTS CHANGE STATE PRIOR TO TRANSFER WITH PRESET TIME DELAY



Westinghouse Automatic Transfer Switch  
Legend for Wiring Diagram Symbols

Symbol	Description
AM	Ammeter
Ex	Power Terminal, Emergency Source (x = Terminal Number)
EASx	Emergency Lockout (x = contact number)
EC	Engine Cooloff Relay Coil
ECx	Engine Cooloff Relay Contact (x = contact number)
EL	Emergency Position Indicator Light
ELS	Emergency Limit Switch
EMPB	Emergency Pushbutton for Manual Operation
EMR	Emergency Relay (Manual Operation)
ER	Emergency Relay Coil
ERx	Emergency Relay Contact (x = contact number)
ERA	Emergency Auxiliary Relay Coil
ERAx	Emergency Auxiliary Relay Contact (x = Contact Number)
ERTM	Generator Run Time Meter
EST	Emergency Shunt Trip
ESx	Emergency Auxiliary Switch (x = contact number)
ET1	Emergency Transformer (Line Voltage to 120vac - 2 windings)
ET2	Emergency Transformer (120 to 24vac CT)
FPSS	Four Position Selector Switch (Option 7)
FR	Frequency Sensing Relay
Fx	Fuse (x = Fuse Number)
KV	Voting Relay
MSS	Maintenance Selector Switch
NASx	Normal Lockout (x = contact number)
Nx	Power Terminal, Normal (x = Terminal number)
NL	Normal Position Indicator Light
NLS	Normal Limit Switch
NMPB	Normal Pushbutton for Manual Operation
NR	Normal Relay Coil
NRx	Normal Relay Contact (x = contact number)
NRA	Normal Auxiliary Relay Coil
NRAx	Normal Auxiliary Relay Contact (x = contact number)
NST	Normal Shunt Trip
NSx	Normal Auxiliary Switch (x = contact number)
NT1	Normal Transformer (Line Voltage to 120vac - 2 windings)
NT2	Normal Transformer (120 to 24vac CT)
Px-y	Plug (x = number, y = Terminal number)
PBEN	Bypass TDEN Pushbutton
PBNE	Bypass TDNE Pushbutton
PBRE	Pushbutton Reset Emergency Trip
PBRN	Reset Normal Breaker Trip Pushbutton
PE	Plant Exerciser
PSDR	Pre-Transfer Signal Device Relay
PSDT	Pre-Transfer Signal Device Timer
Sx-y	Socket (x = number, y = Terminal number)
SDL	Service Disconnect Light
SDSS	Service Disconnect Selector Switch
SE	Emergency Source Available Indicator Light
SN	Normal Source Available Indicator Light
Tx	Power Terminal, Load (x = Terminal Number)
TDCL	Time Delay Crank Time Limiter
TDEC	Time Delay Engine Cool Down
TDEN	Time Delay Emergency to Normal
TDES	Time Delay Engine Start
TDNC	Time Delay Neutral
TDNE	Time Delay Normal to Emergency
TE	Emergency Trip Indicator Light
TM	Transfer Motor and Brake
TN	Normal Trip Indicator Light
TPB	Test Pushbutton
TSS	Test Selector Switch
VM	Voltmeter

# **Cutler-Hammer Beaver, PA**

Automatic Transfer Switch

Type **ATSRM** Wiring Diagrams

Cutler-Hammer  
Power Distribution Components Division  
One Tuscarawas Road  
Beaver, PA 15009

Copyright 1995 by Eaton/Cutler-Hammer Inc.  
All Rights Reserved

Version 1.2 10-9-92

# Cutler-Hammer Automatic Transfer Switch Wiring Diagrams

## Directions for Use

The drawing package can be used as a point to point wiring diagram for maintenance and diagnostic purposes for Solid State Logic SPB Transfer Switches, all voltages.

This document contains the following wiring information:

### **Page 1**

Basic Solid State Intelligence Panel Wiring exclusive of added option functions

### **Page 2**

Power Switching Panel basic wiring exclusive of added option functions.

### **Pages 3 - 18**

Wiring for optional functions

### **Page 19**

Legend Sheet describing symbols used throughout this document

Note: Unnumbered sheets may be added to this document on specific occasions to illustrate custom options additions per order instructions.

All transfer switch units will be standardly wired as indicated by Pages 1, and 2. The Intelligence Panel and Power Panel are interconnected via keyed plug/socket connectors (P1-S1/P2-S2). Your specific unit may be equipped with certain optional functions as noted which require additional wiring as shown on pages 3 - 18.

Wiring for optionally added functions will typically interface with the basic unit wiring (Pages 1-2) which should be used as the base reference.

Note: **BOLD** lines on option wiring indicate components and wiring added to the basic wiring diagram to accomplish that specific option function.

# Cutler-Hammer Automatic Transfer Switch

## Standard Features

### **Test Pushbutton**

Simulates a power failure in the logic. Will cause the Generator to start, and load to transfer to the Emergency Source.

### **Undervoltage Protection on NORMAL (All phases)**

Monitors the voltage on the NORMAL Source for an undervoltage condition. Should the voltage drop below a preset Dropout, the generator is started and transfer to the EMERGENCY Source takes place.

### **Engine Start Contact**

Contact that provides a closure to Engine Controller when the NORMAL Source fails.

### **Logic Disconnect**

Plugs provided to disconnect the logic circuitry for maintenance purposes.

### **Auxiliary Contacts**

Auxiliary contacts integral to the switching devices rated at 120 VAC, 10 amps. These may be applied for customer use, and may be applied to certain customer specified options.

### **Fully Rated Neutral**

A fully rated solid neutral is supplied on all two and three pole switches. All four pole switches are supplied with switched neutral contacts of identical construction and rating as the power poles.

# SPB ATS INTELLIGENCE PANEL

NOTE A

NOTE B:  
 TRANSFORMERS NT3, NT4 AND WIRES 180, 188 USED FOR 3 PHASE NORMAL SENSING  
 TRANSFORMERS ET3, ET4 AND WIRES 114, 116 USED FOR 3 PHASE EMERGENCY SENSING  
 (OPTION 5F AND/OR 5G)

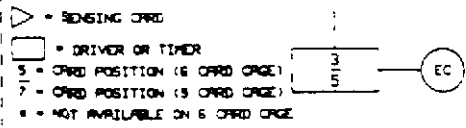
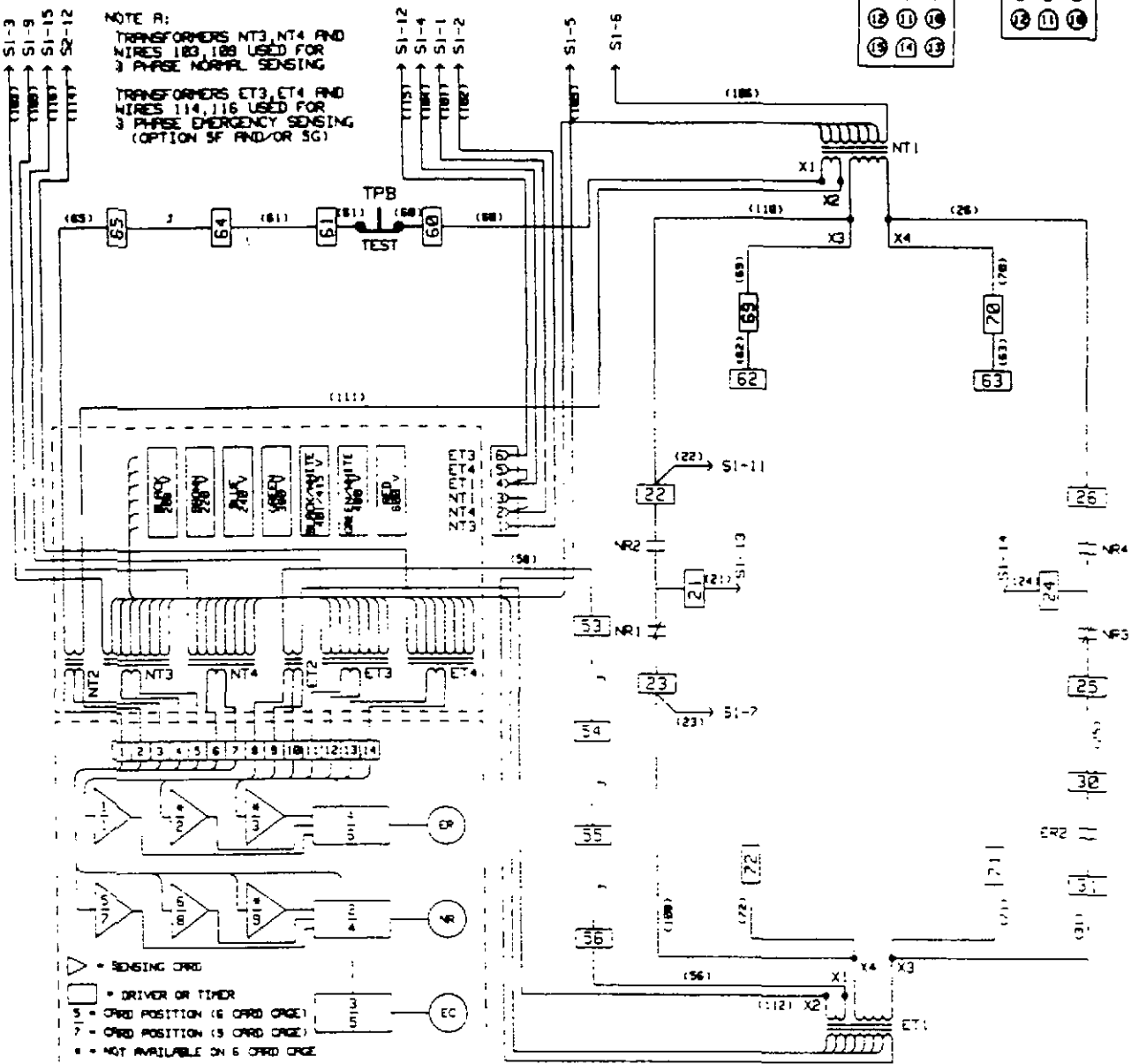
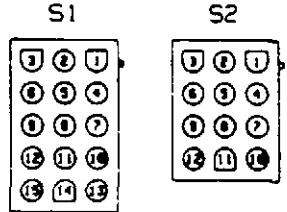

- △ SENSING CARD
- DRIVER OR TIMER
- 5 CARD POSITION (6 CARD CRGE)
- 7 CARD POSITION (8 CARD CRGE)
- NOT AVAILABLE ON 6 CARD CRGE

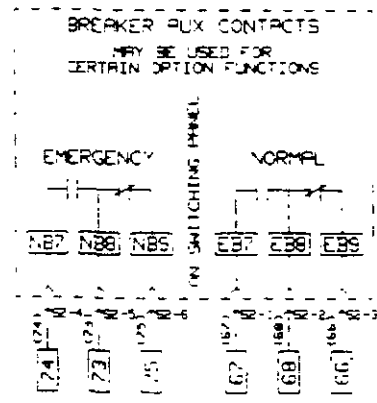
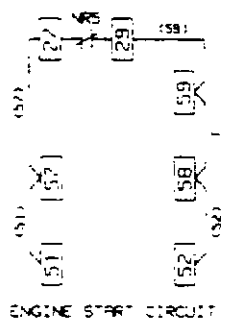

# SPB POWER SWITCHING PANEL (FIXED MOUNT)

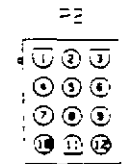
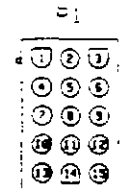
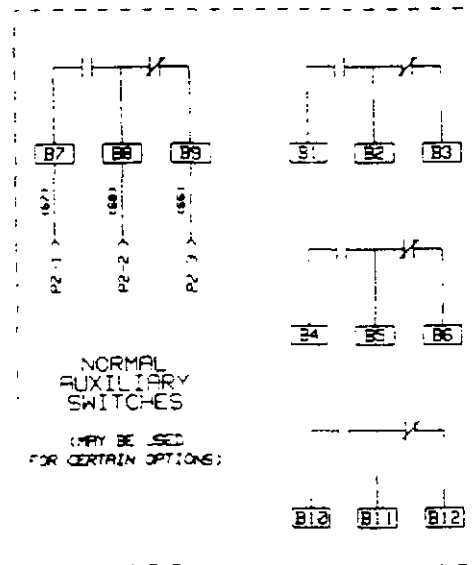
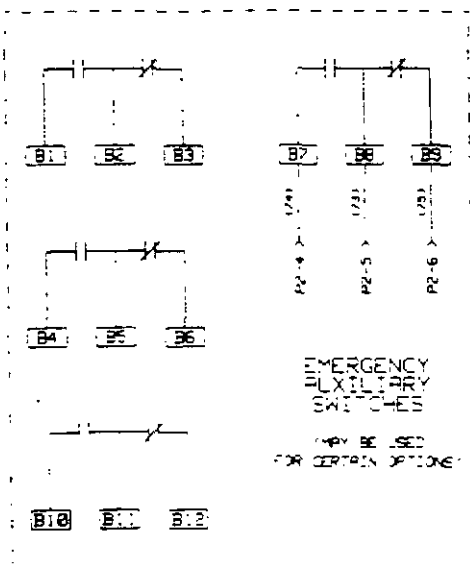
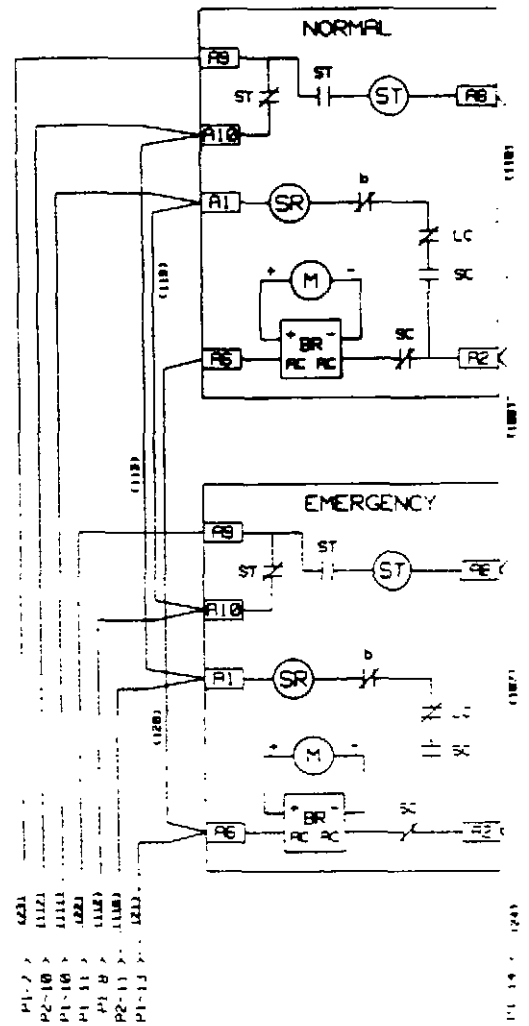
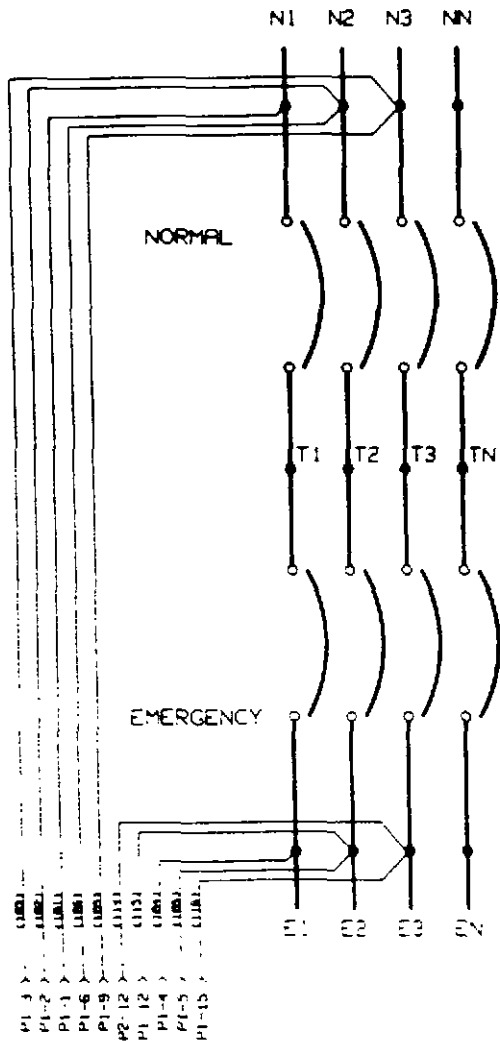

6 POSITION CARD CAGE

NORMAL		ENG	EMERGENCY		
1	2	3	4	5	6
UNDERVOLTAGE	STD	DRIVER (OPTION 3)	BLANK (OPTION 4)	DRIVER (OPTION 1)	BLANK (OPTION 5)
					BLANK (OPTION 5)

9 POSITION CARD CAGE

NORMAL				ENG	EMERGENCY			
1	2	3	4	5	6	7	8	9
UNDERVOLTAGE	STD	BLANK (OPTION 26)	BLANK (OPTION 26)	DRIVER (OPTION 3)	BLANK (OPTION 4)	DRIVER (OPTION 1)	BLANK (OPTION 5)	BLANK (OPTION 5)
								BLANK (OPTION 5)

OPTION 1 - TIME DELAY NORMAL TO EMERGENCY (TDNE)

6 POSITION CARD CAGE  
REPLACE DRIVER CARD IN POSITION 4  
WITH TIMER CARD

9 POSITION CARD CAGE  
REPLACE DRIVER CARD IN POSITION 6  
WITH TIMER CARD

OPTION 3 - TIME DELAY EMERGENCY TO NORMAL (TDEN)

6 POSITION CARD CAGE  
REPLACE DRIVER CARD IN POSITION 2  
WITH TIMER CARD

9 POSITION CARD CAGE  
REPLACE DRIVER CARD IN POSITION 4  
WITH TIMER CARD

OPTION 4 - TIME DELAY ENGINE COOLOFF (TDEC)

6 POSITION CARD CAGE  
REPLACE BLANK CARD IN POSITION 3  
WITH TIMER CARD  
ADD EC RELAY TO MOTHERBOARD

9 POSITION CARD CAGE  
REPLACE BLANK CARD IN POSITION 5  
WITH TIMER CARD  
ADD EC RELAY TO MOTHERBOARD

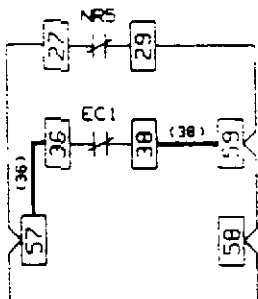

OPTION 4 ONLY

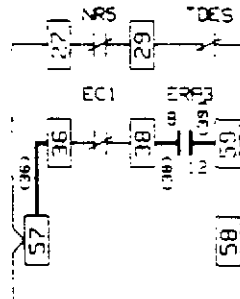

OPTION 4 WITH 2 \*\*  
\*\* REQUIRES OPTION 14D

OPTION 5 - EMERGENCY SENSING (UV,CV,UF,OF)

6 POSITION CARD CAGE  
REPLACE BLANK CARD IN POSITION 5 OR 6  
WITH APPROPRIATE SENSING CARD

9 POSITION CARD CAGE  
REPLACE BLANK CARD IN POSITION 7,8 OR 9  
WITH APPROPRIATE SENSING CARD

OPTION 25 - NORMAL SENSING (CV,UF,OF)

6 POSITION CARD CAGE  
NOT AVAILABLE

9 POSITION CARD CAGE  
REPLACE BLANK CARD IN POSITION 3 OR 4  
WITH APPROPRIATE SENSING CARD

\* UNDERVOLTAGE SENSING ON NORMAL IS STANDARD

OPTION 2 - TIME DELAY ENGINE START (TDES)

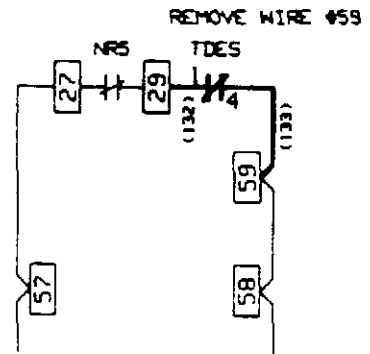
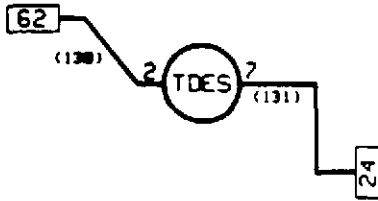

OPTION 6D - TEST SELECTOR (TSS)

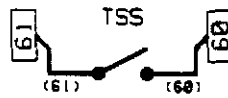

REPLACES STANDARD TEST PUSHBUTTON

OPTION 6H - FOUR POSITION SELECTOR SWITCH (FPSS)

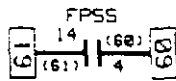

REPLACES STANDARD TEST SELECTOR SWITCH

FPSS	L9 18T	L11 12	L14 14T	L15 16T	L17 18
TEST	X	X	X	X	X
AUTO	X	X	X	X	X
OFF	X	X	X	X	X
ENG. RUN	X	X	X	X	X

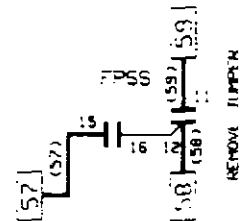
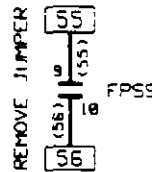
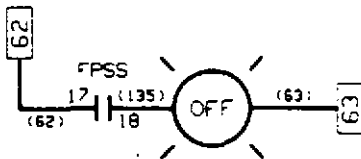

OPTION 8C - BYPASS TDEN TIMER (PBEN)

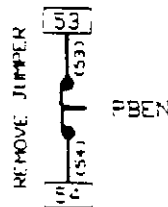

OPTION 8D - BYPASS TIME TIMER (PBNE)

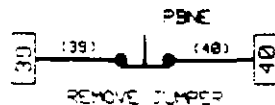

# OPTION 9 - MAINTENANCE SELECTOR SWITCH

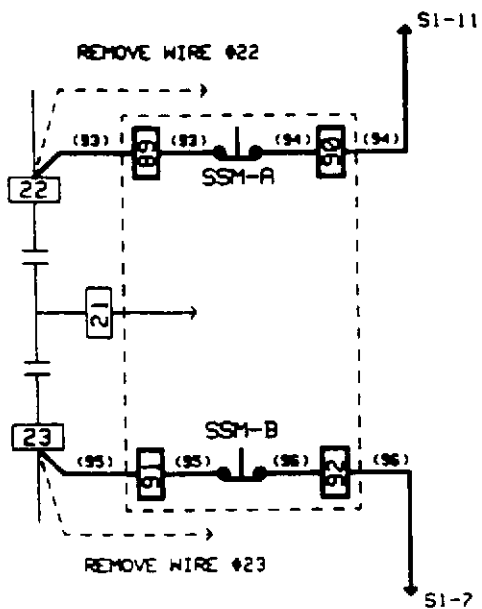

- OPTION 12C - NORMAL POSITION LIGHT (NL)  
INDICATES LOAD IS CONNECTED TO NORMAL

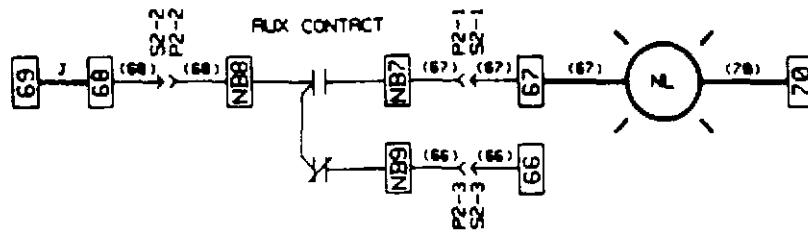

- OPTION 12D - EMERGENCY POSITION LIGHT (EL)  
INDICATES LOAD IS CONNECTED TO EMERGENCY

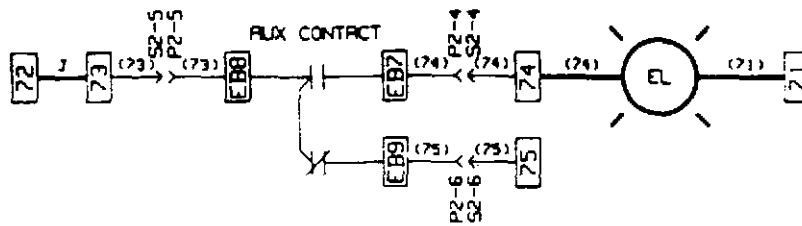

- OPTION 12G - NORMAL SOURCE LIGHT (SN)  
INDICATES NORMAL SOURCE AVAILABLE

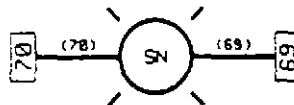

- OPTION 12H - EMERGENCY SOURCE LIGHT (SE)  
INDICATES EMERGENCY SOURCE AVAILABLE

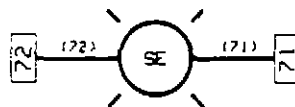



OPTION 14C - NORMAL AUXILIARY RELAY (NRA)  
 PROVIDES ADDITIONAL RELAY CONTACTS ON NORMAL

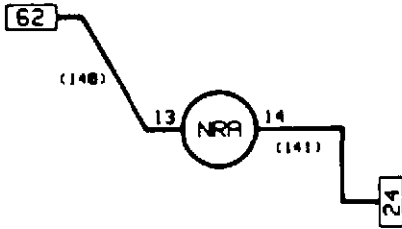

NOTE: CUSTOMER CONTACTS ARE ON RELAY SOCKET  
 SEE SOCKET DIAGRAM BELOW

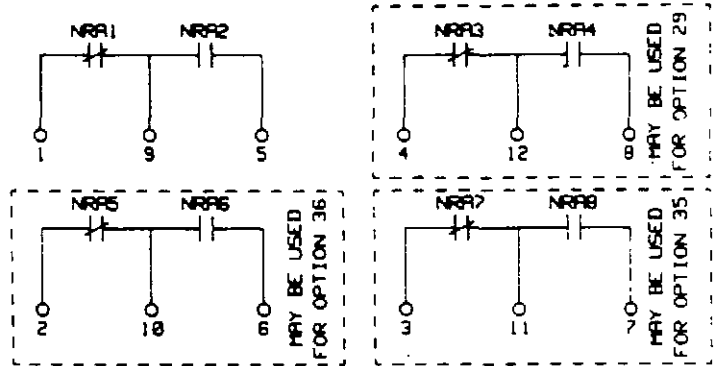

OPTION 14D - EMERGENCY AUXILIARY RELAY (ERA)  
 PROVIDES ADDITIONAL RELAY CONTACTS ON EMERGENCY



NOTE: CUSTOMER CONTACTS ARE ON RELAY SOCKET  
 SEE SOCKET DIAGRAM BELOW

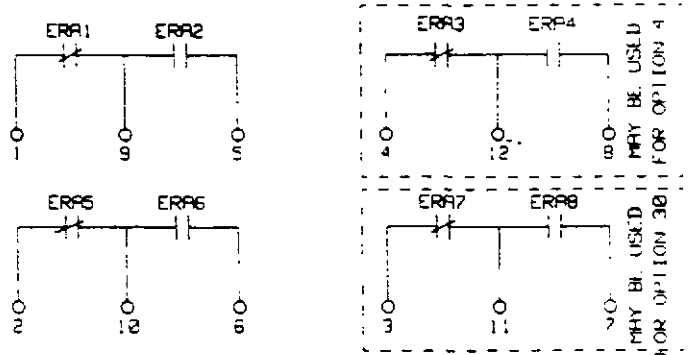

NRA - ERA SOCKET DIAGRAM

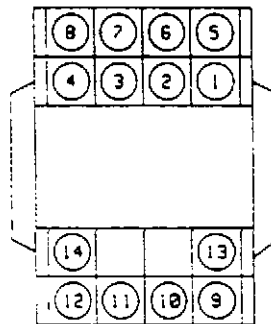

OPTION 16 - SPB DIGITRIP

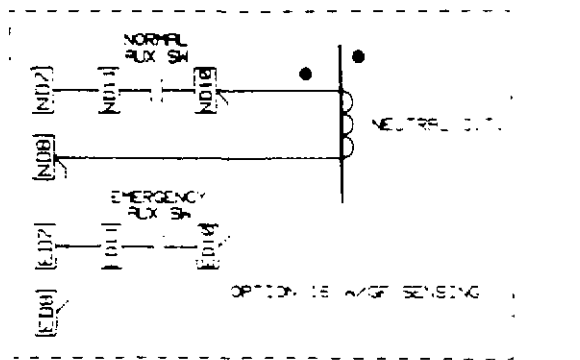
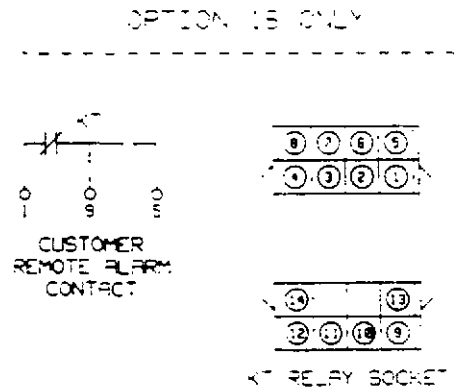
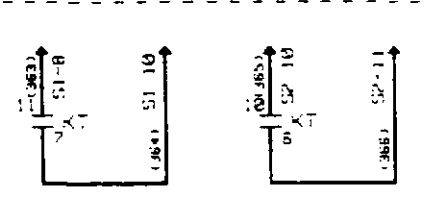
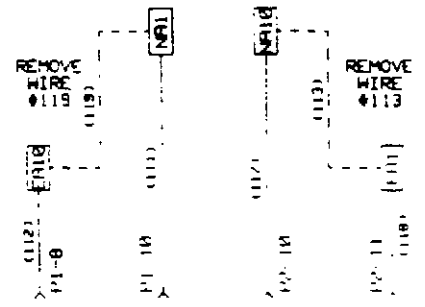
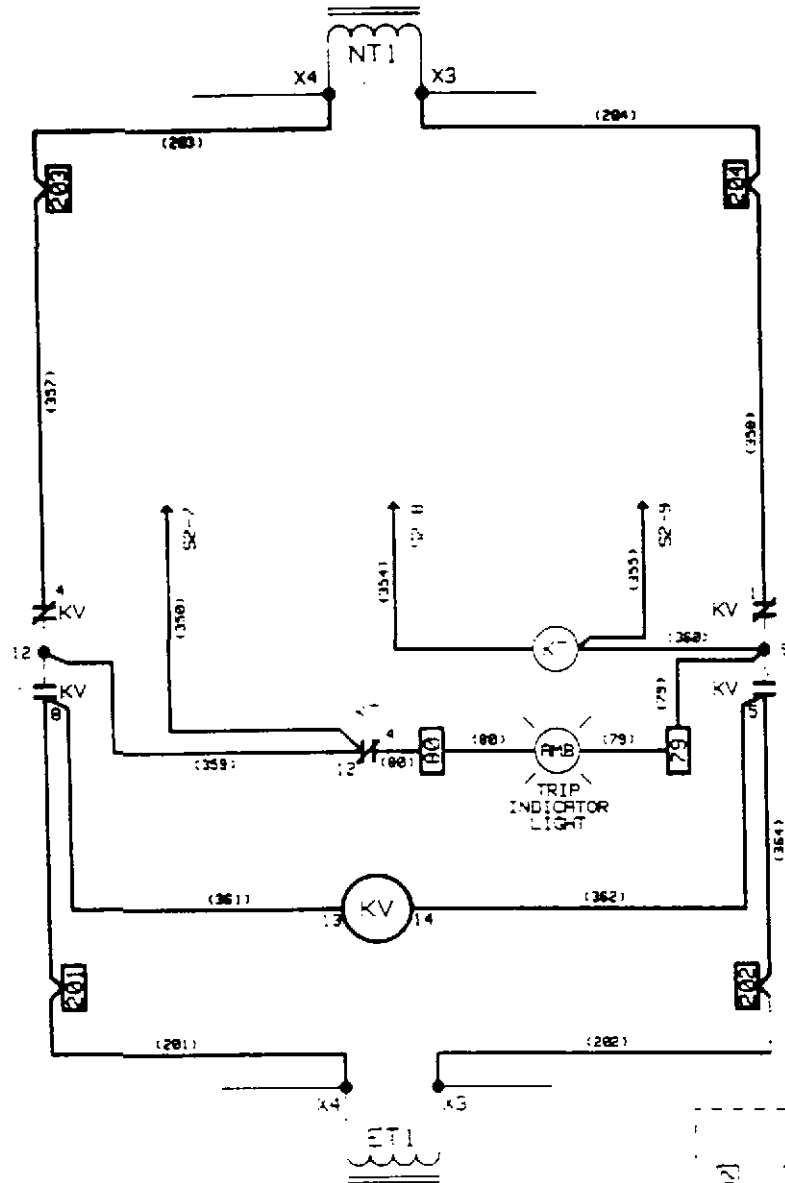
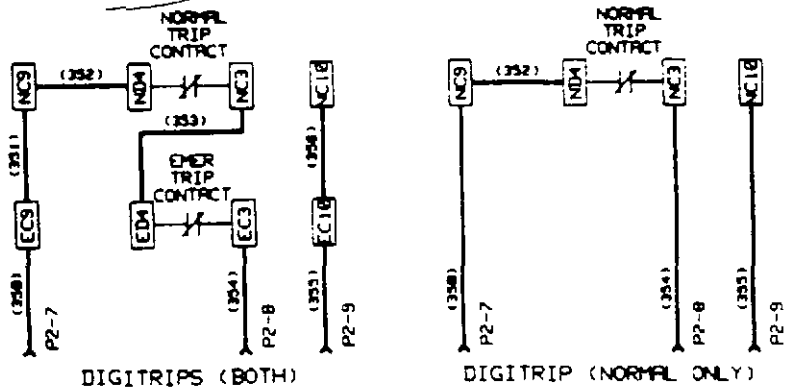

OPTION 18E - VOLTMETER

	HANDLE POSITION					
	NORMAL			EMERGENCY		
	1-3	2-3	1-2	1-2	2-3	1-3
1 -  2				X		X
3 -  4	X		X			
5 -  6					X	
7 -  8		X				
9 -  10						X
11 -  12	X					
13 -  14				X	X	
15 -  16		X	X			

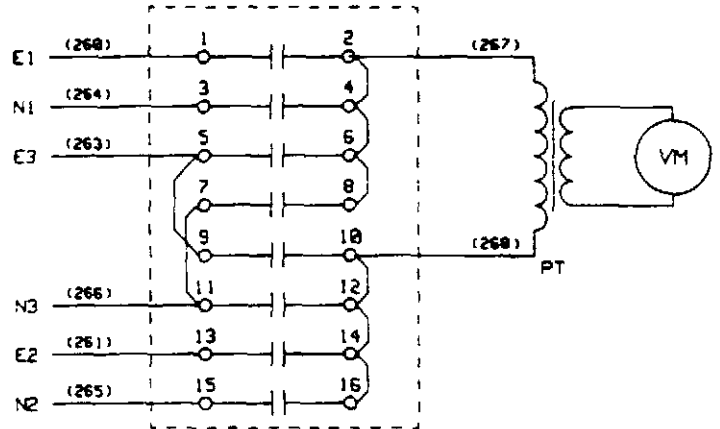

OPTION 18F - AMMETER

	HANDLE POSITION			
	OFF	1	2	3
1 -  2	X	X	X	X
3 -  4	X	X	X	X
5 -  6	X	X	X	X
7 -  8	X	X	X	X
9 -  10	X	X	X	X
11 -  12	X	X	X	X

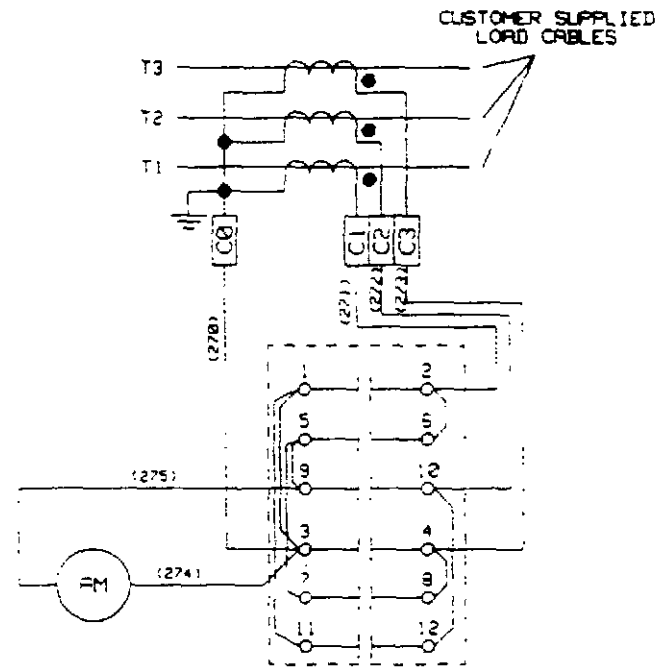

OPTION 18G - FREQUENCY METER

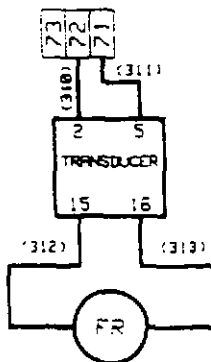

OPTION 18H - RUNNING TIME METER

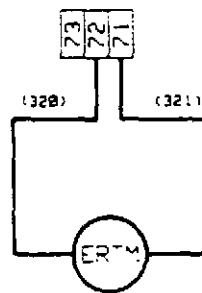

OPTION 23C - PLANT EXERCISER  
 RUN ENGINE AT SPECIFIED TIME  
 (NO LOAD)

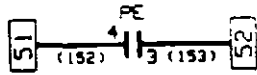
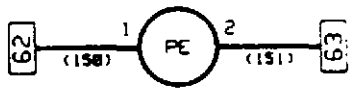

PE TERMINAL BLOCK

OPTION 23I = 23D W/FAILSAFE  
 OPTION 23J = 23G W/FAILSAFE

OPTION 23D - PLANT EXERCISER  
 RUN ENGINE AT SPECIFIED TIME  
 (LOAD)

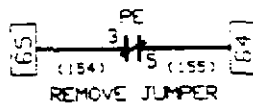

FAILSAFE CIRCUIT

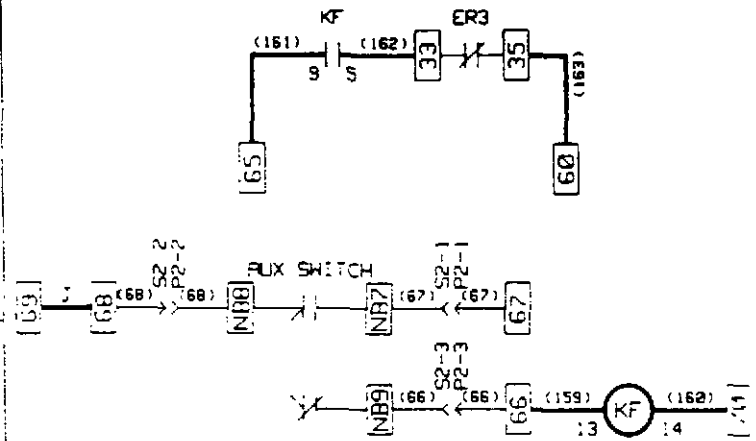

OPTION 23G - PLANT EXERCISER  
 RUN ENGINE AT SPECIFIED TIME  
 (SWITCH SELECTABLE  
 LOAD OR NO LOAD)

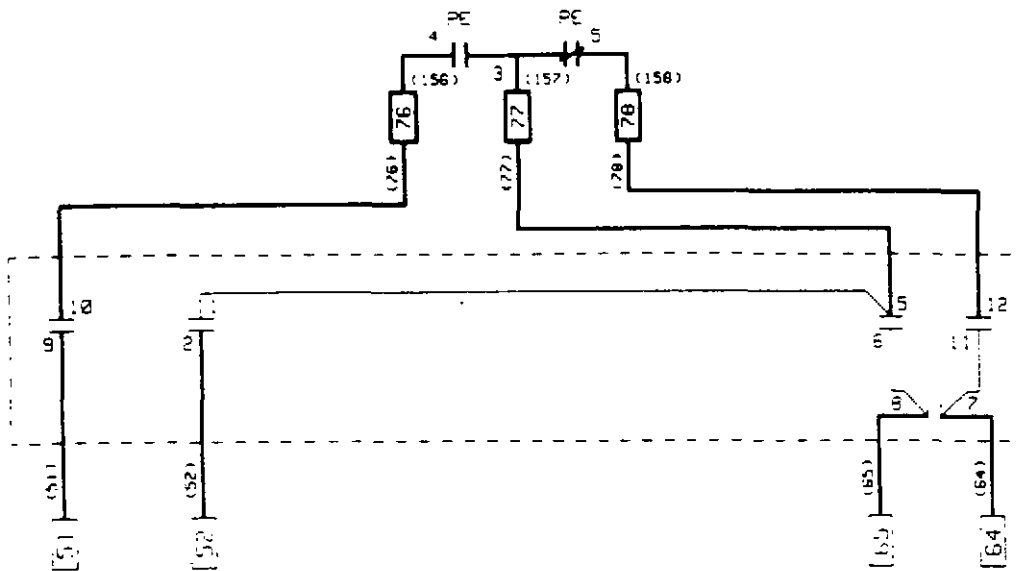

	ENGINE RUN	BYPASS	LOAD
1 - 2		X	
5 - 6			X
7 - 8	X	X	
9 - 10	X	X	
11 - 12			X

OPTION 28A - INTELLIGENCE CIRCUIT FUSES  
FUSES NON-ESSENTIAL CIRCUITRY ONLY

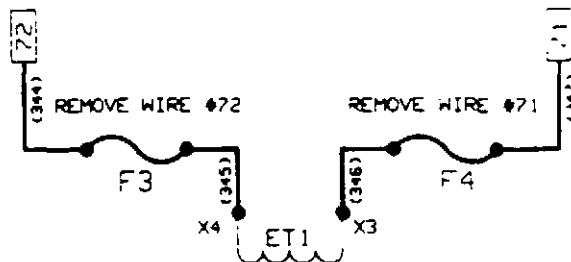
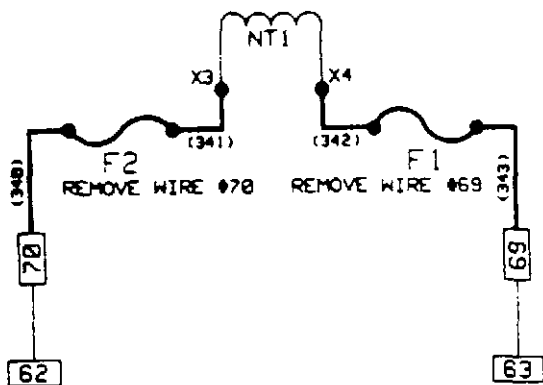

OPTION 30 - TIME DELAY CRANK LIMITER (TDCL)  
INTERUPTS ENGINE START CIRCUIT IF VOLTAGE DOES NOT APPEAR WITHIN A PRESELECTED TIME

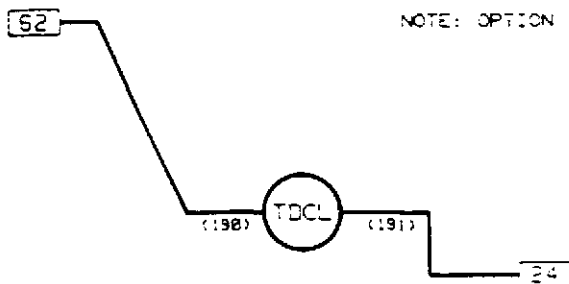

NOTE: OPTION 146 REQUIRED

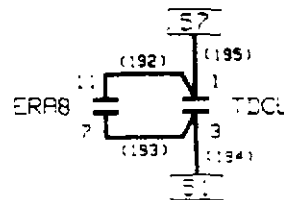

OPTION 31B - ADJUSTABLE ALARM SILENCE SWITCH  
ALARM WHEN THIS INTERRUPT IS CONNECTED TO EMERGENCY

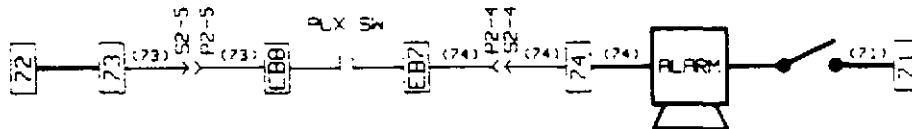

OPTION 31: ONLY

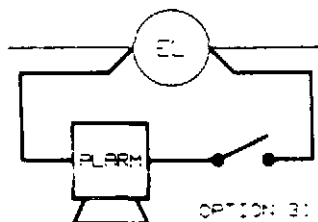

OPTION 31: WITH OPTION 120

OPTION 29E - MANUAL RETURN TO NORMAL (NMPB)

REQUIRES OPTION 14C  
OPTION 3 MAY NOT BE USED

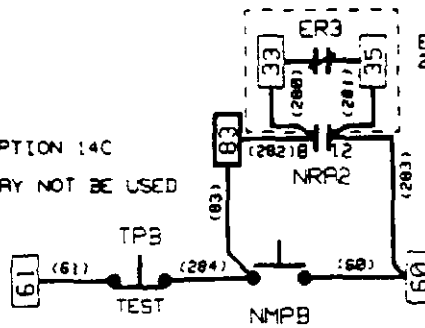

ELIMINATE IF OPTIONS 23I OR 23J ARE USED

OPTION 29J AUTOMATIC/MANUAL RETURN TO NORMAL

REQUIRES OPTION 14C

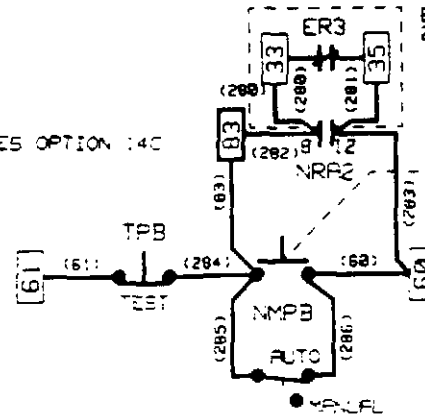

ELIMINATE IF OPTIONS 23I OR 23J ARE USED

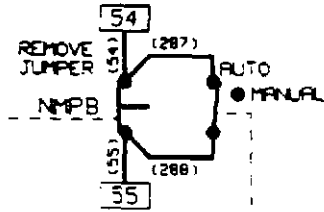

OPTION 29G - AUTOMATIC/MANUAL OPERATION

REQUIRES OPTION 14C

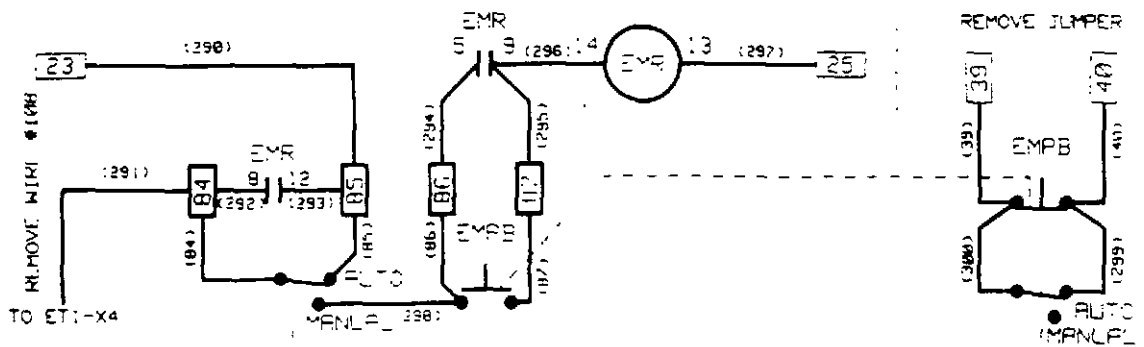
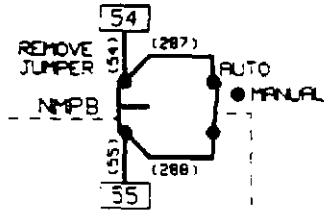
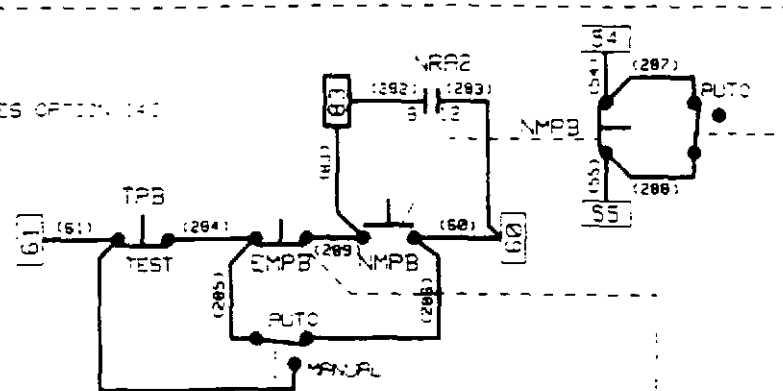



# OPTION 35 - PRETRANSFER SIGNAL DEVICE

(OPTION 14 REQUIRED)

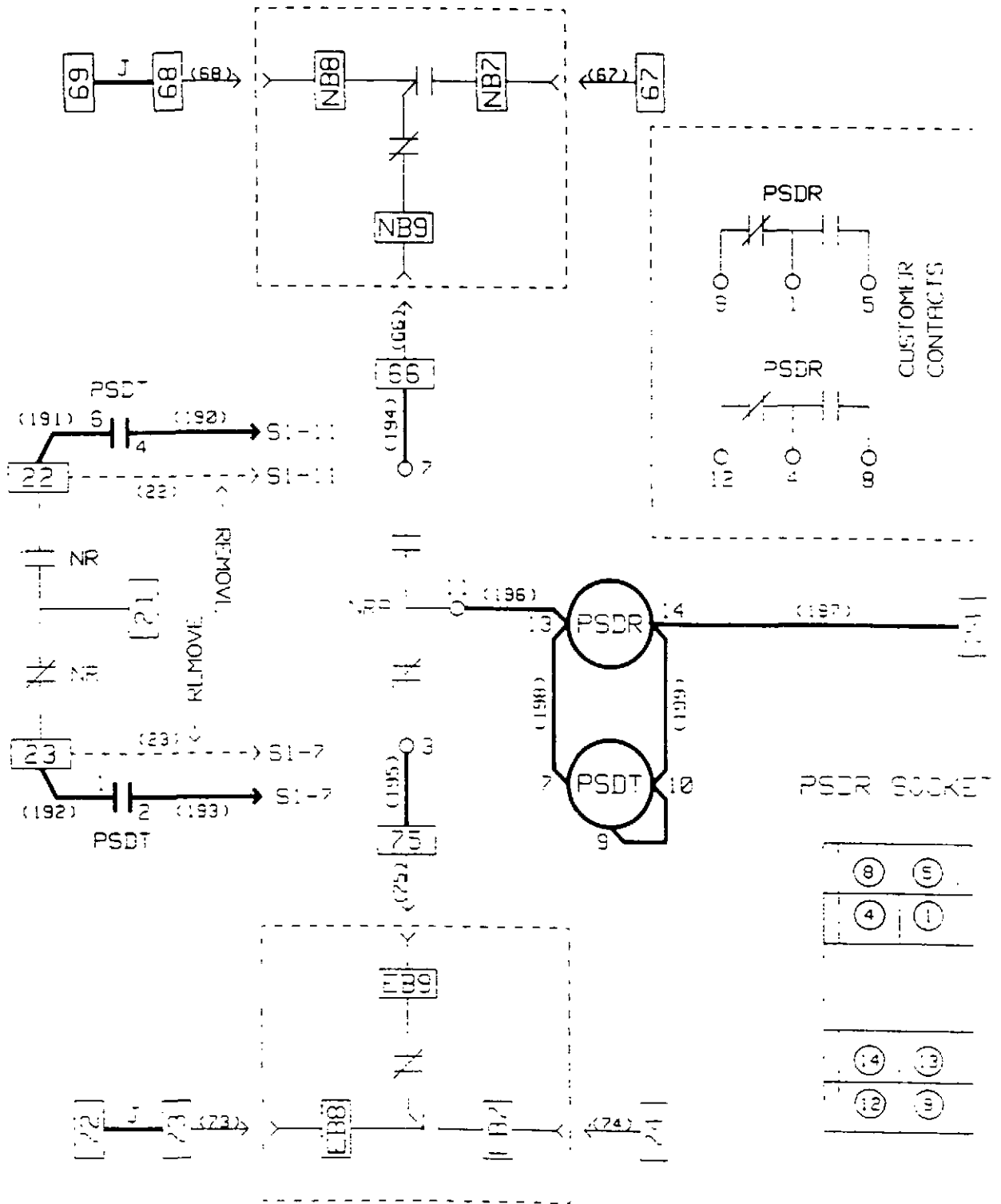

OPTION 32 - TIME DELAY NEUTRAL

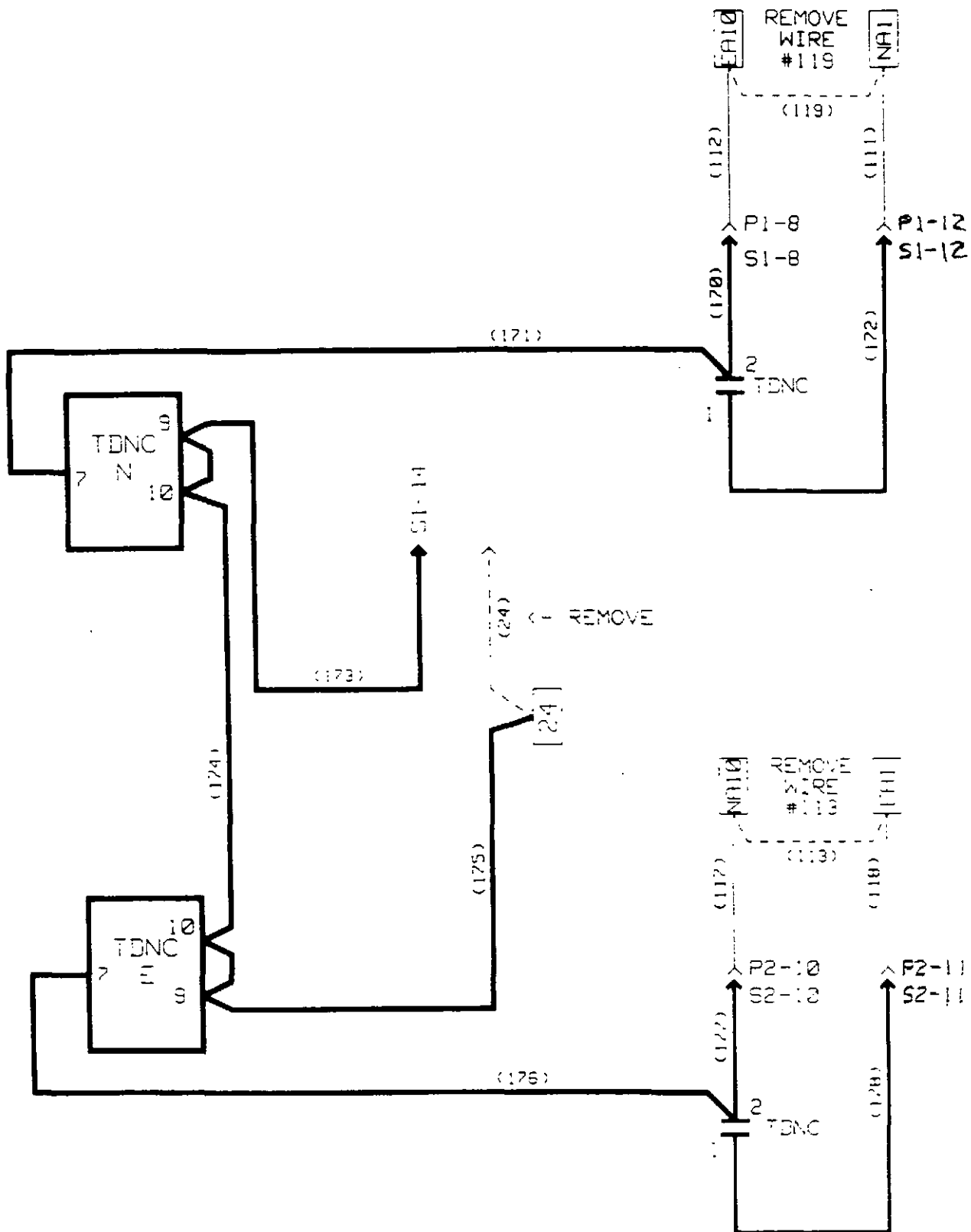

OPTION 36 - LOAD SHED

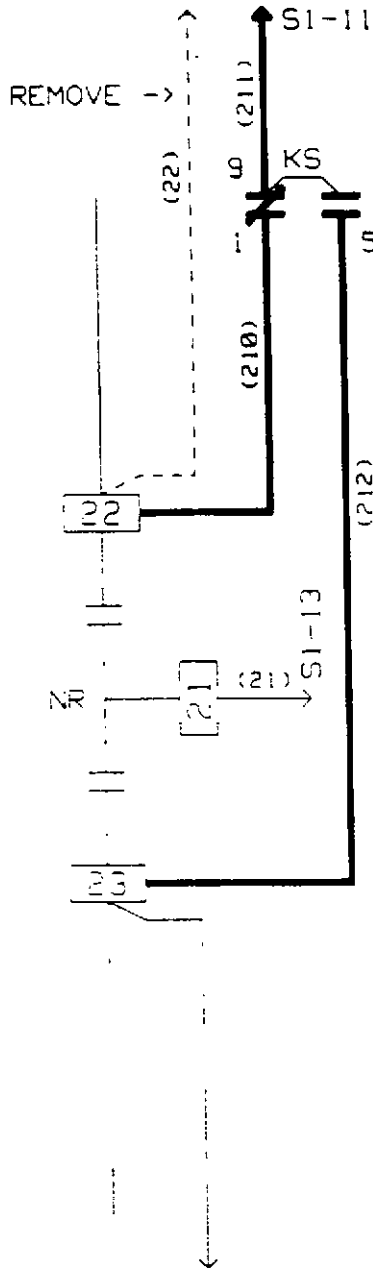

KS RELAY SOCKET

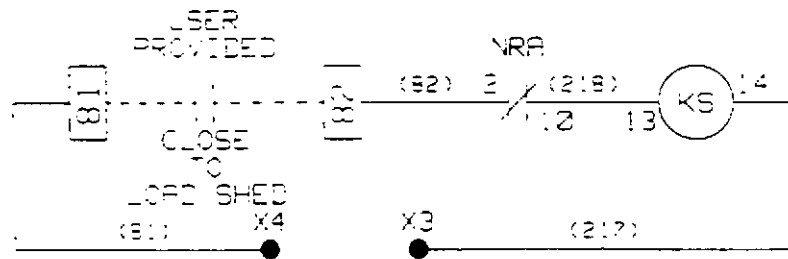
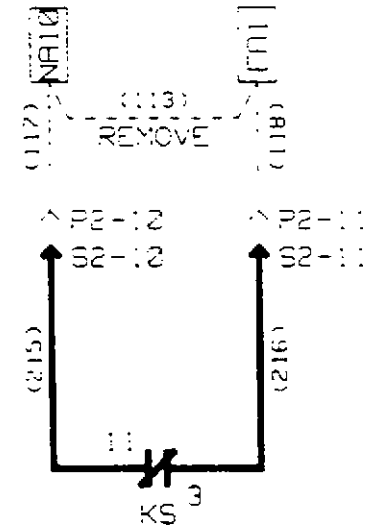
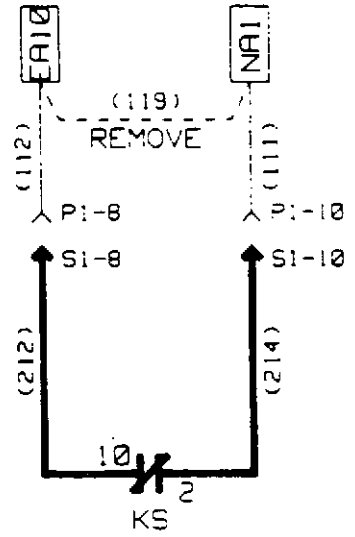
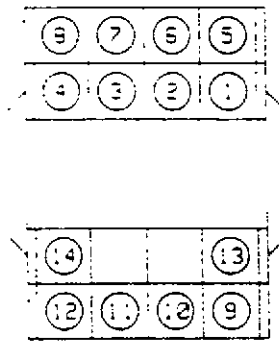

ET:

OPTION 37 - SERVICE ENTRANCE  
(MUST USE OPTION 16)

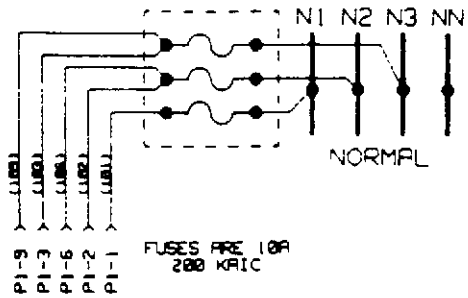

KV IS PROVIDED  
W/ OPTION 16

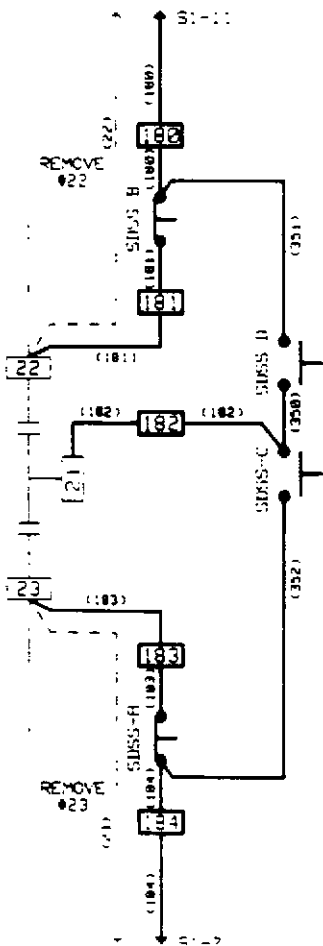
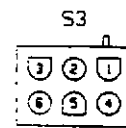
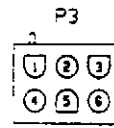
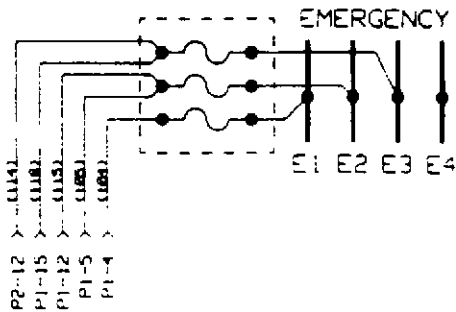
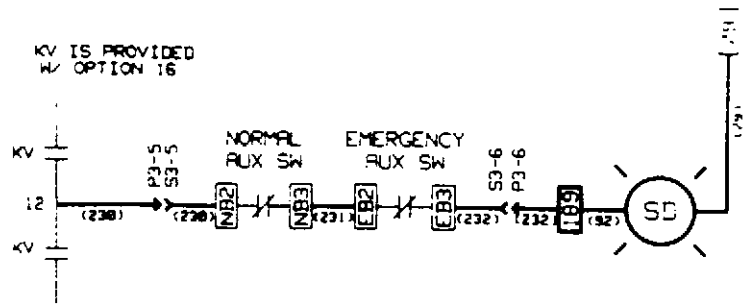

SERVICE  
DISCONNECT (EMERGENCY)  
SEL SW

DISCONNECT X X  
ENERGIZE X X X X

KEY LOCKED  
KEY REMOVABLE  
IN "DISCONNECTED" POSITION

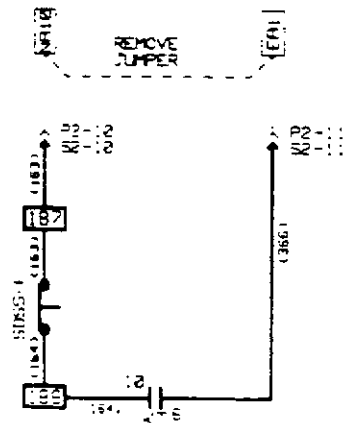
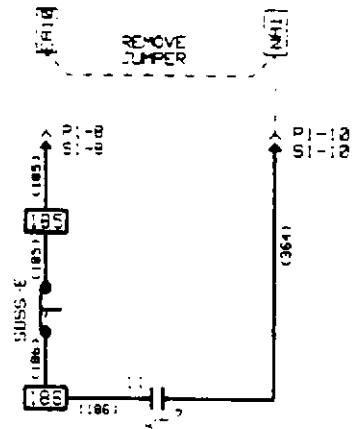



Westinghouse SPB Automatic Transfer Switch  
Legend for Wiring Diagram Symbols

Symbol	Description
AM	Ammeter
Ex	Power Terminal, Emergency Source (x = Terminal Number)
EASx	Emergency Lockout (x = contact number)
EC	Engine Cooloff Relay Coil
ECx	Engine Cooloff Relay Contact (x = contact number)
EL	Emergency Position Indicator Light
EMPB	Emergency Pushbutton for Manual Operation
EMR	Emergency Relay (Manual Operation)
ER	Emergency Relay Coil
ERx	Emergency Relay Contact (x = contact number)
EPA	Emergency Auxiliary Relay Coil
EPAx	Emergency Auxiliary Relay Contact (x = Contact Number)
ERTM	Generator Run Time Meter
ESx	Emergency Auxiliary Switch (x = contact number)
ET1	Emergency Transformer (Line Voltage to 120vac - 2 windings)
ET2	Emergency Transformer (120 to 24vac CT)
ET3	Emergency Transformer (Line Voltage to 12vac)
ET4	Emergency Transformer (Line Voltage to 12vac)
FSS	Four Position Selector Switch (Option 6H)
FR	Frequency Meter
Fx	Fuse (x = Fuse Number)
KS	Failsafe Relay
KS	Load Shed Relay
KT	Trip Relay (Used w/Option 16)
KV	Voting Relay
MSS	Maintenance Selector Switch
NASx	Normal Lockout (x = contact number)
Nx	Power Terminal, Normal (x = Terminal number)
NL	Normal Position Indicator Light
NMPB	Normal Pushbutton for Manual Operation
NR	Normal Relay Coil
NRx	Normal Relay Contact (x = contact number)
NRA	Normal Auxiliary Relay Coil
NRAx	Normal Auxiliary Relay Contact (x = contact number)
NSx	Normal Auxiliary Switch (x = contact number)
NT1	Normal Transformer (Line Voltage to 120vac - 2 windings)
NT2	Normal Transformer (120 to 24vac CT)
NT3	Normal Transformer (Line Voltage to 12vac)
NT4	Normal Transformer (Line Voltage to 12vac)
Px-y	Plug (x = number, y = Terminal number)
PBEN	Bypass TDEN Pushbutton
PBNE	Bypass TDNE Pushbutton
PBRE	Pushbutton Reset Emergency Trip
PBRN	Reset Normal Breaker Trip Pushbutton
PE	Plant Exerciser
PDR	Pre-Transfer Signal Device Relay
PDT	Pre-Transfer Signal Device Timer
PSS	Preferred Source Selector Switch
Sx-y	Socket (x = number, y = Terminal number)
SDL	Service Disconnect Light
SDSS	Service Disconnect Selector Switch
SD	Services Disconnected Light
SE	Emergency Source Available Indicator Light
SN	Normal Source Available Indicator Light
Lx	Power Terminal, Load (x = Terminal Number)
TDCL	Time Delay Crank Time Limiter
TDEC	Time Delay Engine Cool Down
TDEN	Time Delay Emergency to Normal
TDES	Time Delay Engine Start
TDNC	Time Delay Neutral
TDNE	Time Delay Normal to Emergency
TE	Emergency Trip Indicator Light
TM	Transfer Motor and Brake
TN	Normal Trip Indicator Light
TPB	Test Pushbutton
TSS	Test Selector Switch
VM	Voltmeter

# **Automatic Transfer Switch Wiring Diagrams**

**Catalog Number ATSBM Only  
Solid State Transfer Switch**

**Shop Order:**

**Westinghouse Electric Corporation  
Electrical Components Division  
250 Westinghouse Drive  
London, KY 40741**

**(C) Copyright 1990,1991,1992 by Westinghouse Electric Corporation  
All Rights Reserved**

**ATSBM-WD V2.3 12-17-92**

# Westinghouse Automatic Transfer Switch

## Standard Features

### **Test Pushbutton**

Simulates a power failure in the logic. Will cause the Generator to start, and load to transfer to the Emergency Source.

### **Undervoltage Protection on NORMAL (All phases)**

Monitors the voltage on the NORMAL source for an undervoltage condition. Should the voltage drop below a preset Dropout, the generator is started and transfer to the EMERGENCY Source takes place.

### **Engine Start Contact**

Contact that provides a closure to Engine controller when the NORMAL source fails.

### **Logic Disconnect**

Plug provided to disconnect the logic circuitry for maintenance purposes.

### **Motor Disconnect**

Plug provided to disconnect the motor circuit for testing of the logic circuitry without transfer.

### **Auxiliary Contacts**

Auxiliary contacts integral to the switching devices rated at 120 vac, 10 amps. These may be applied for customer use, and may be applied to certain customer specified options.

### **Fully Rated Neutral**

A fully rated solid neutral is supplied on all two and three pole switches. All four pole switches are supplied with switched neutral contacts of identical construction and rating as the power poles.

# Westinghouse Automatic Transfer Switch Wiring Diagrams

## Directions for Use

The drawing package can be used as a point to point wiring diagram for maintenance and diagnostic purposes for Solid State Logic Transfer Switches, 100 - 1000 Amperes, All voltages.

This document contains the following wiring information:

### **Page 1**

Basic Solid State Intelligence Panel Wiring exclusive of added option functions

### **Page 2**

Power Switching Panel basic wiring 100, 400, 600, 800, and 1000 amperes exclusive of added option functions.

### **Page 3**

Power Switching Panel basic wiring 150 - 300 amperes exclusive of added option functions.

### **Pages 4 - 15**

Wiring for optional functions

### **Page 16**

Legend Sheet describing symbols used throughout this document

**Note:** Unnumbered sheets may be added to this document on specific occasions to illustrate custom options additions per order instructions.

All transfer switch units will be standardly wired as indicated by Pages 1, and Pages 2 or 3. The Intelligence Panel and Power Panel are interconnected via keyed plug/socket connectors (P1-S1/P2-S2). Your specific unit may be equipped with certain optional functions as noted which require additional wiring as shown on pages 4 - 12.

Wiring for optionally added functions will typically interface with the basic unit wiring (Pages 1 - 3) which should be used as the base reference.

**Note:** BOLD lines on option wiring indicate components and wiring added to the basic wiring diagram to accomplish that specific option function.

# POWER SWITCHING PANEL

100, 400, 600, 800, AND 1000 AMP

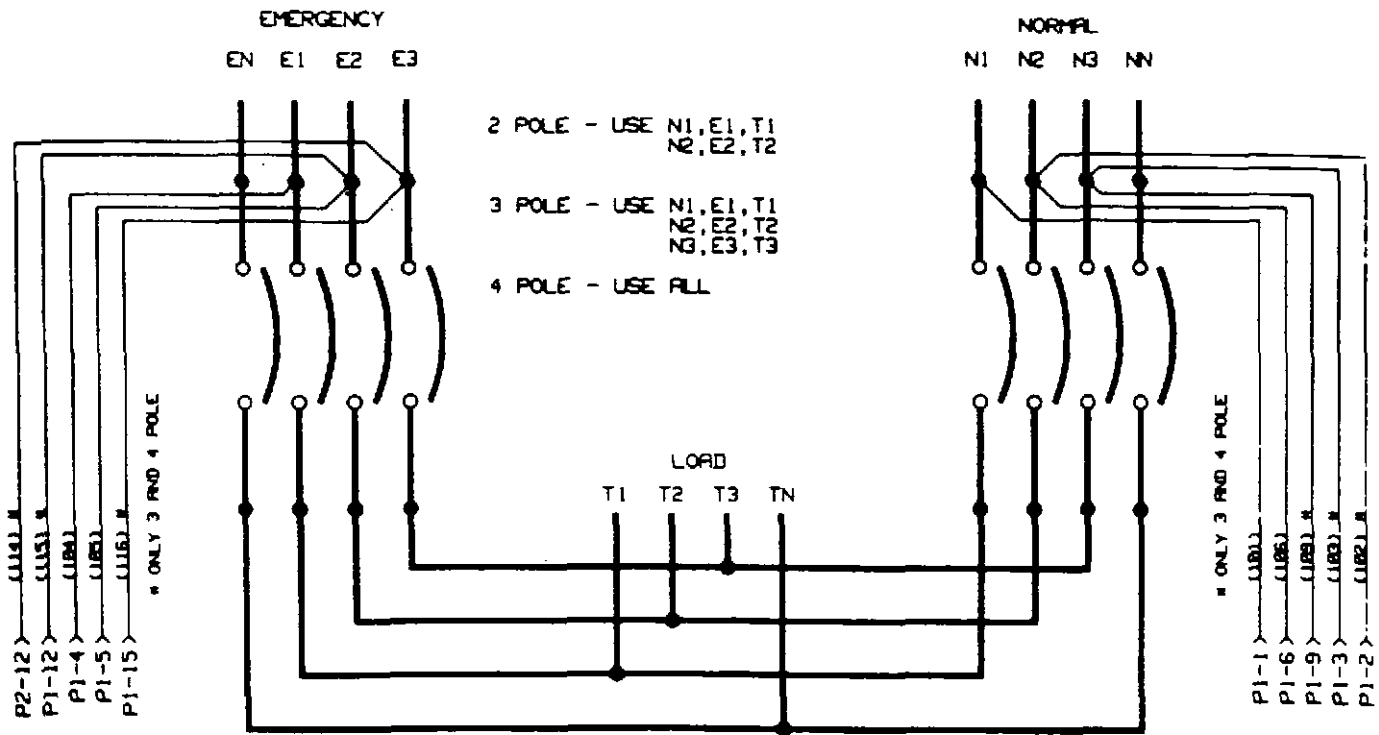

EMERGENCY SOURCE  
AUX. CONTACTS

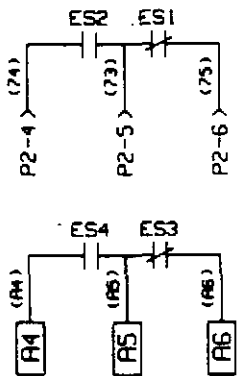

EMERGENCY  
LIMIT  
SWITCH

AUX CONTACTS MAY BE USED FOR  
CERTAIN OPTIONS  
(SEE OPTIONS 12 AND 32)

NORMAL  
LIMIT  
SWITCH

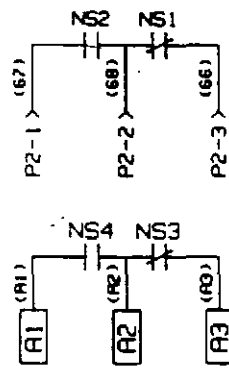

NORMAL SOURCE  
AUX. CONTACTS

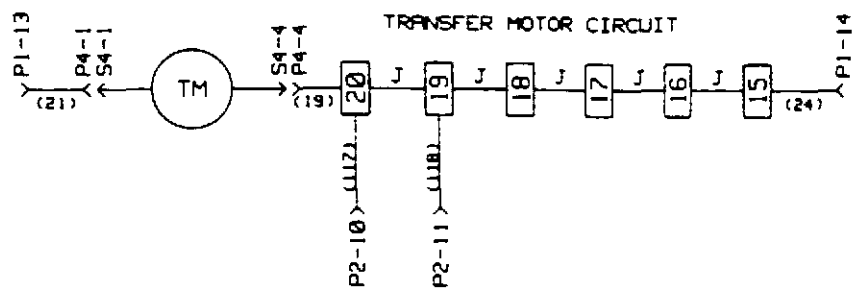

TRANSFER MOTOR CIRCUIT



# POWER SWITCHING PANEL

## 150 - 300 AMP

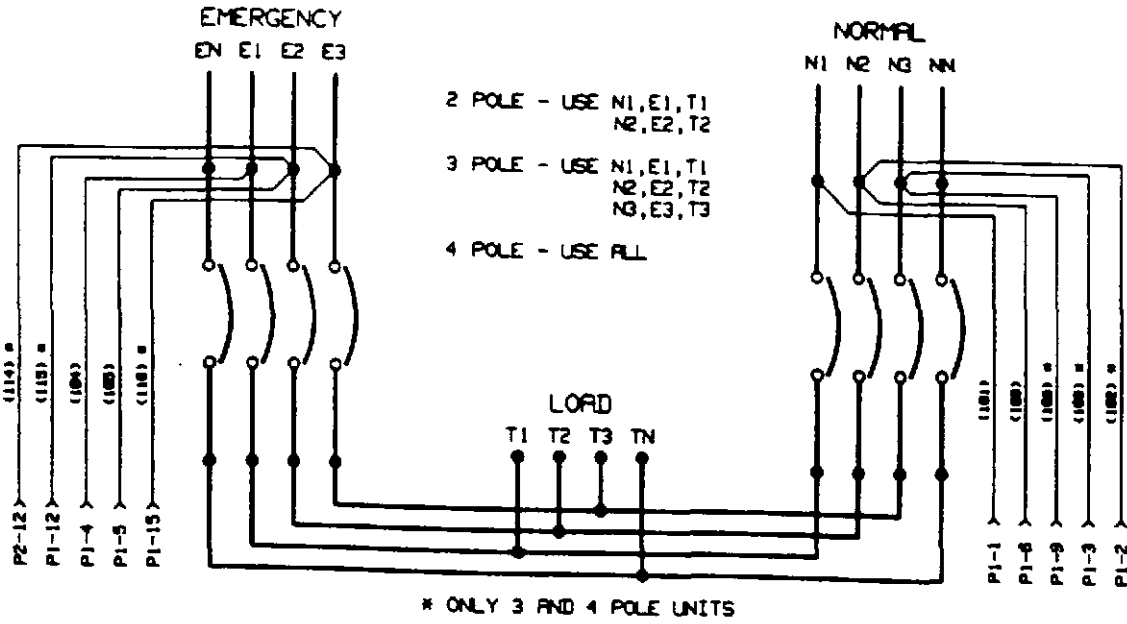

- 2 POLE - USE N1, E1, T1  
N2, E2, T2
- 3 POLE - USE N1, E1, T1  
N2, E2, T2  
N3, E3, T3
- 4 POLE - USE ALL

\* ONLY 3 AND 4 POLE UNITS

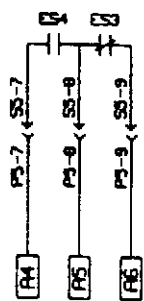
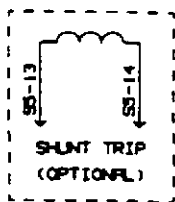
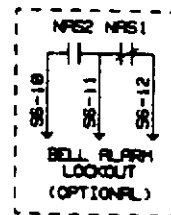
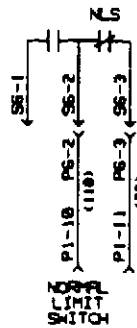
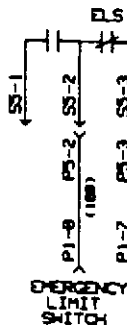
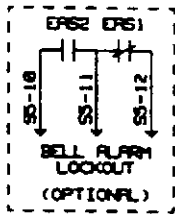

EMERGENCY AUX CONTACTS

AUXILIARY CONTACTS MAY BE USED FOR CERTAIN OPTIONS (SEE OPTIONS 12 AND 32)

NORMAL AUX CONTACTS

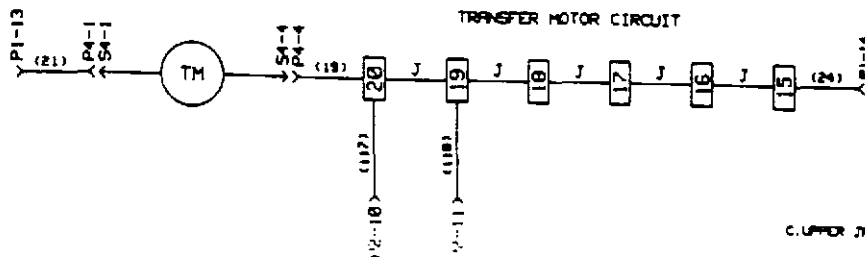
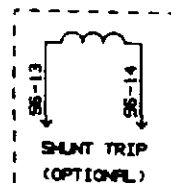
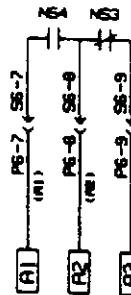

# SOLID STATE INTELLIGENCE PANEL

NOTE 2

NOTE A:

TRANSFORMERS NT3, NT4 AND WIRES 103, 108 USED FOR 3 PHASE NORMAL SENSING

TRANSFORMERS ET3, ET4 AND WIRES 114, 116 USED FOR 3 PHASE EMERGENCY SENSING (OPTION 5F AND/OR 5G)

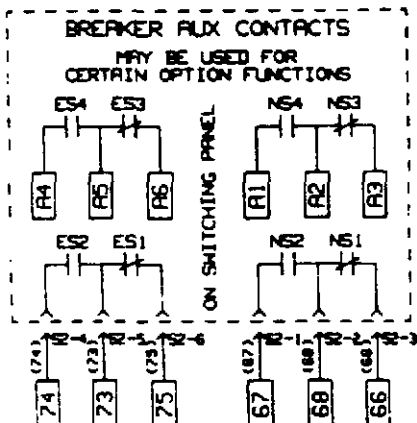
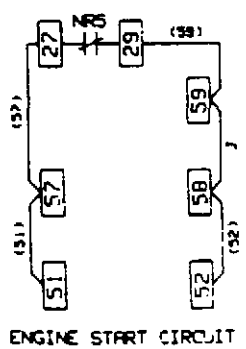
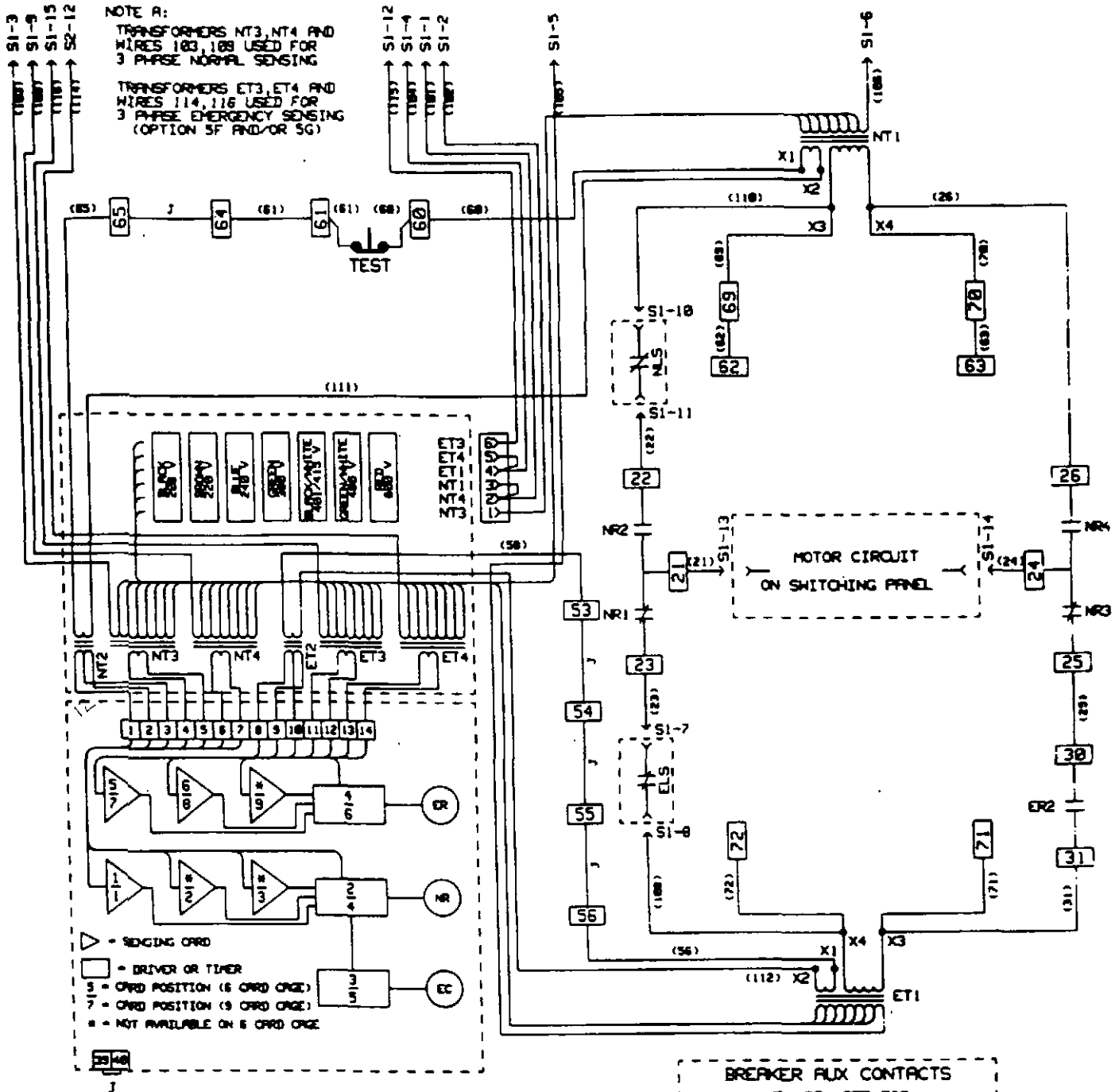

6 POSITION CARD CAGE

NORMAL		ENG	EMERGENCY		
1	2	3	4	5	6
UNDERVOLTAGE	STD	DRIVER (OPTION 3)	BLANK (OPTION 4)	DRIVER (OPTION 1)	BLANK (OPTION 5)
					BLANK (OPTION 5)

9 POSITION CARD CAGE

NORMAL			ENG	EMERGENCY				
1	2	3	4	5	6	7	8	9
UNDERVOLTAGE	STD	BLANK (OPTION 26)	BLANK (OPTION 26)	DRIVER (OPTION 3)	BLANK (OPTION 4)	DRIVER (OPTION 1)	BLANK (OPTION 5)	BLANK (OPTION 5)
								BLANK (OPTION 5)

OPTION 1 - TIME DELAY NORMAL TO EMERGENCY (TDNE)

6 POSITION CARD CAGE  
REPLACE DRIVER CARD IN POSITION 4  
WITH TIMER CARD

9 POSITION CARD CAGE  
REPLACE DRIVER CARD IN POSITION 6  
WITH TIMER CARD

OPTION 3 - TIME DELAY EMERGENCY TO NORMAL (TDEN)

6 POSITION CARD CAGE  
REPLACE DRIVER CARD IN POSITION 2  
WITH TIMER CARD

9 POSITION CARD CAGE  
REPLACE DRIVER CARD IN POSITION 4  
WITH TIMER CARD

OPTION 4 - TIME DELAY ENGINE COOLOFF (TDEC)

6 POSITION CARD CAGE  
REPLACE BLANK CARD IN POSITION 3  
WITH TIMER CARD  
ADD EC RELAY TO MOTHERBOARD

9 POSITION CARD CAGE  
REPLACE BLANK CARD IN POSITION 5  
WITH TIMER CARD  
ADD EC RELAY TO MOTHERBOARD

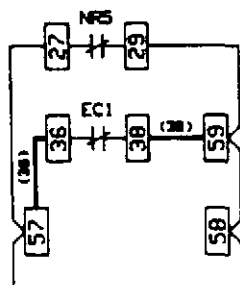

OPTION 4 ONLY

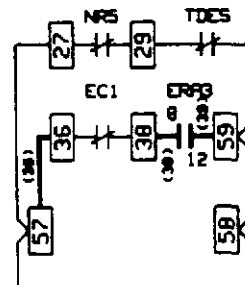

OPTION 4 WITH 2 \*\*  
\*\* REQUIRES OPTION 14D

OPTION 5 - EMERGENCY SENSING (UV,OV,UF,OF)

6 POSITION CARD CAGE  
REPLACE BLANK CARD IN POSITION 5 OR 6  
WITH APPROPRIATE SENSING CARD

9 POSITION CARD CAGE  
REPLACE BLANK CARD IN POSITION 7,8 OR 9  
WITH APPROPRIATE SENSING CARD

OPTION 26 - NORMAL SENSING (OV,UF,OF)

6 POSITION CARD CAGE  
NOT AVAILABLE

9 POSITION CARD CAGE  
REPLACE BLANK CARD IN POSITION 2 OR 3  
WITH APPROPRIATE SENSING CARD

\* UNDERVOLTAGE SENSING ON NORMAL IS STANDARD

OPTION 2 - TIME DELAY ENGINE START (TDES)

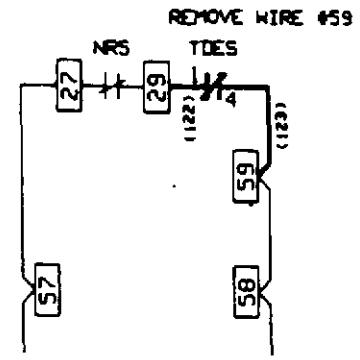
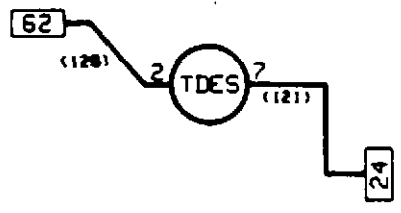

REMOVE WIRE #59

OPTION 6D - TEST SELECTOR SWITCH (TSS)

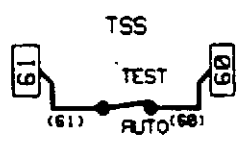

REPLACES STANDARD TEST PUSHBUTTON

OPTION 6H - FOUR POSITION SELECTOR SWITCH (FPSS)

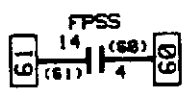

REPLACES STANDARD TEST PUSHBUTTON

FPSS	1-9 16T	1-11 12T	1-14 14T	1-13 16T	1-17 16T
TEST					
AUTO	X	X	X	X	
OFF					
ENG. RUN	X			X	X

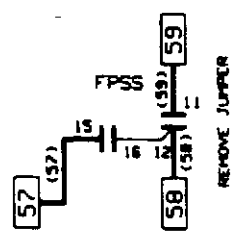
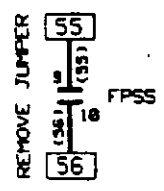
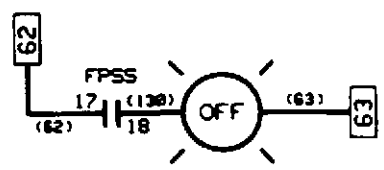

OPTION 8C - BYPASS TDEN TIMER (PBEN)

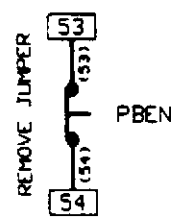

OPTION 8D - BYPASS TDNE TIMER (PBNE)

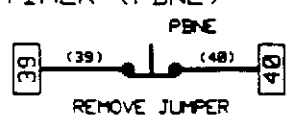

- OPTION 9B - MAINTENANCE SELECTOR SWITCH (MSS)  
PROVIDES A MOTOR CIRCUIT DISCONNECT TO PREVENT TRANSFER DURING ATS MAINTENANCE

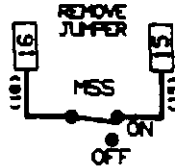

- OPTION 11D - PUSHBUTTON RESET NORMAL (PBRN)  
PROVIDES PUSHBUTTON RESET OF LOCKOUT

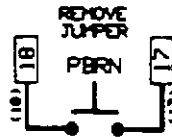

NOTE: ONLY AVAILABLE IF OPTIONS 11F, 16, OR 17 ARE PROVIDED

NOTE: NOT AVAILABLE ON 100 AMP

- OPTION 11E - PUSHBUTTON RESET EMERGENCY (PBRE)  
PROVIDES PUSHBUTTON RESET OF LOCKOUT

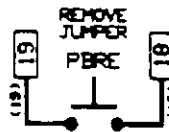

NOTE: ONLY AVAILABLE IF OPTIONS 11F, 16, OR 17 ARE PROVIDED

NOTE: NOT AVAILABLE ON 100 AMP

- OPTION 11F - TRIP LOCKOUT (NRS) (ERS)  
PREVENTS TRANSFER AFTER BREAKER TRIP

(PROVIDED AS STANDARD WITH THERMAL MAGNETIC TRIP UNITS OPTION 16 OR 17) NOTE: NOT USED ON 100 AMP

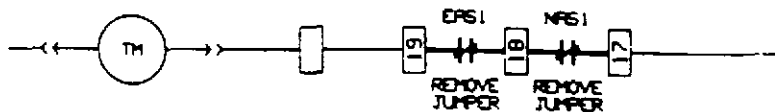

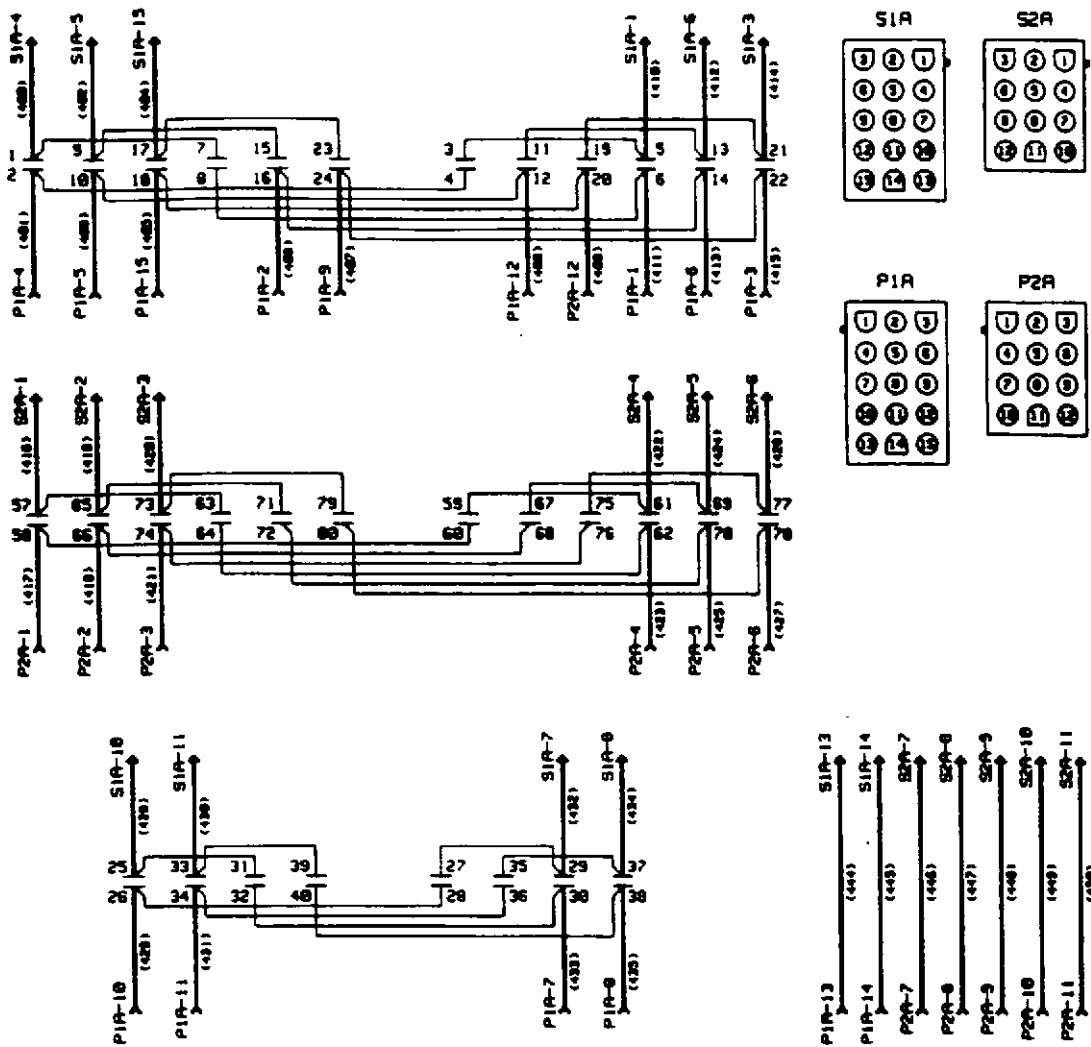

PREFERRED SOURCE SELECTOR SWITCH	1-2	3-4	5-6	7-8	9-10	11-12	13-14	15-16	17-18	19-20	21-22	23-24	25-26	27-28	29-30	31-32	33-34	35-36	37-38	39-40	41-42	43-44	47-48	49-50	51-52	53-56	57-58	61-62	63-64	67-68	69-70	71-72	73-74	75-76	77-78	79-80	
NORMAL	X	X	X	X	X	X	X	X	X	X	X	X	X	X	X	X	X	X	X	X	X	X	X	X	X	X	X	X	X	X	X	X	X	X	X	X	X
EMERGENCY	X	X	X	X	X	X	X	X	X	X	X	X	X	X	X	X	X	X	X	X	X	X	X	X	X	X	X	X	X	X	X	X	X	X	X	X	X

(X) PART NO. 698B730-01

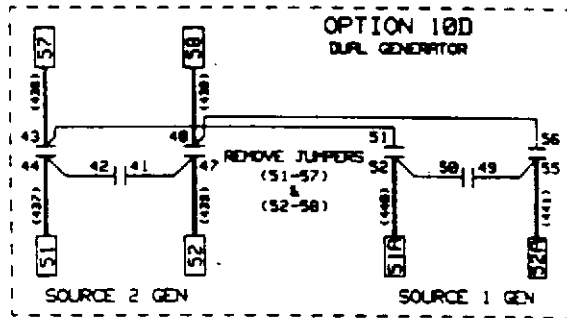
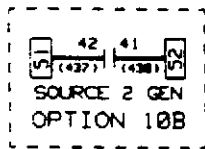
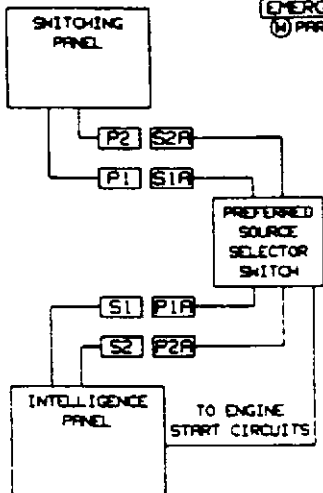

- OPTION 12C - NORMAL POSITION LIGHT (NL)  
INDICATES LOAD IS CONNECTED TO NORMAL

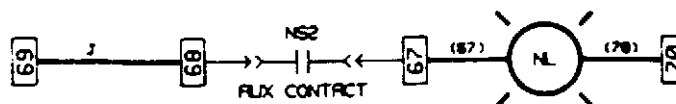

- OPTION 12D - EMERGENCY POSITION LIGHT (EL)  
INDICATES LOAD IS CONNECTED TO EMERGENCY

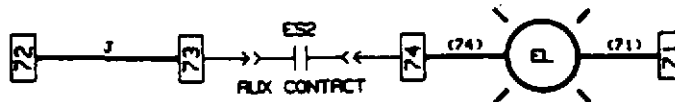

- OPTION 12G - NORMAL SOURCE LIGHT (SN)  
INDICATES NORMAL SOURCE AVAILABLE

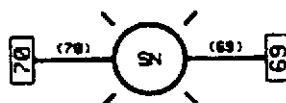

- OPTION 12H - EMERGENCY SOURCE LIGHT (SE)  
INDICATES EMERGENCY SOURCE AVAILABLE



- OPTION 12L - NORMAL TRIPPED INDICATOR (TN)  
INDICATES OVERLOAD TRIP ON NORMAL

NOTE: ONLY AVAILABLE WHEN  
OPTION 11F IS SUPPLIED

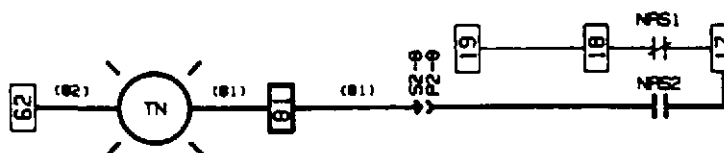

- OPTION 12M - EMERGENCY TRIPPED INDICATOR (TE)  
INDICATES OVERLOAD TRIP ON EMERGENCY

NOTE: ONLY AVAILABLE WHEN  
OPTION 11F IS SUPPLIED

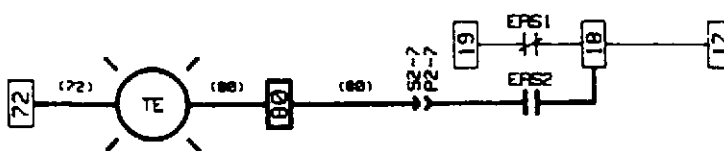

OPTION 14C -- NORMAL AUXILIARY RELAY (NRA)  
 PROVIDES ADDITIONAL RELAY CONTACTS ON NORMAL

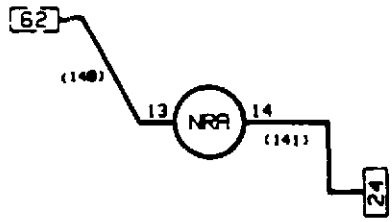

NOTE: CUSTOMER CONTACTS ARE ON RELAY SOCKET  
 SEE SOCKET DIAGRAM BELOW

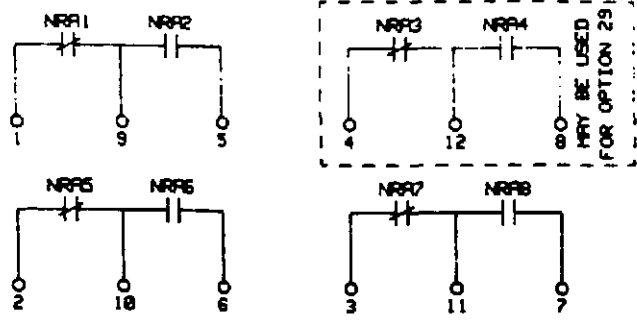

*W  
D*

OPTION 14D - EMERGENCY AUXILIARY RELAY (ERA)  
 PROVIDES ADDITIONAL RELAY CONTACTS ON EMERGENCY



NOTE: CUSTOMER CONTACTS ARE ON RELAY SOCKET  
 SEE SOCKET DIAGRAM BELOW

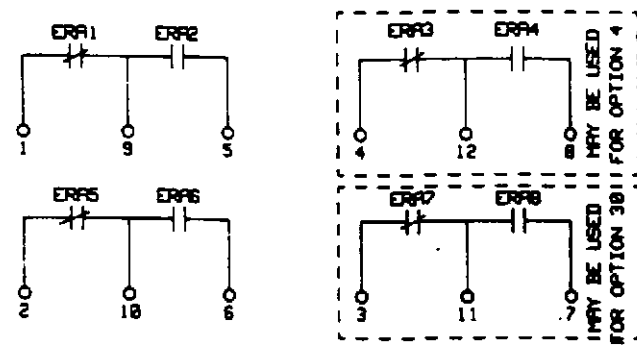

NRA - ERA SOCKET DIAGRAM

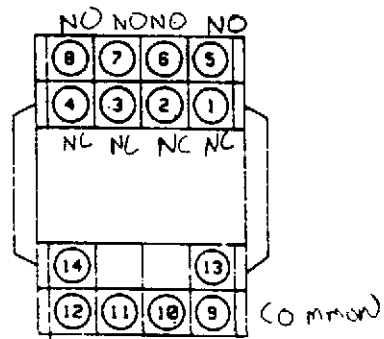

OPTION 18E - VOLTMETER

	HANDLE POSITION					
	NORMAL			EMERGENCY		
	1-3	2-3	1-2	1-2	2-3	1-3
1 -  2				X	X	X
3 -  4	X		X			
5 -  6					X	X
7 -  8		X				
9 -  10						X
11 -  12	X					
13 -  14				X	X	X
15 -  16		X	X			

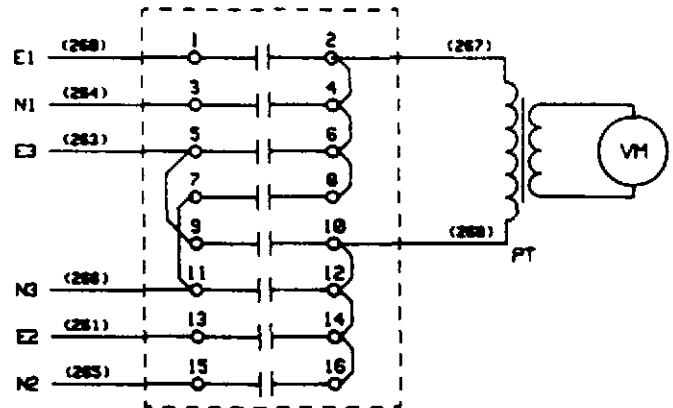

OPTION 18F - AMMETER

	HANDLE POSITION						
	OFF	-	1	-	2	-	3
1 -  2	X	X	X	X	X	X	X
3 -  4	X	X	X	X	X	X	X
5 -  6	X	X	X	X	X	X	X
7 -  8	X	X	X	X	X	X	X
9 -  10	X	X	X	X	X	X	X
11 -  12	X	X	X	X	X	X	X

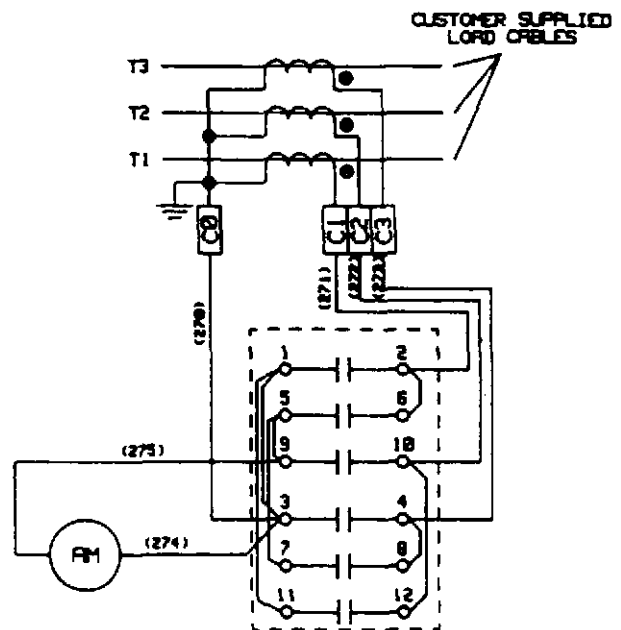

OPTION 18G - FREQUENCY METER

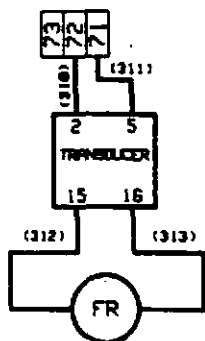

OPTION 18H - RUNNING TIME METER

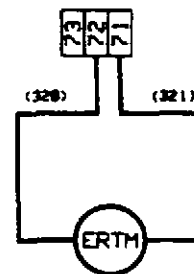

- OPTION 23C - PLANT EXERCISER  
RUN ENGINE AT SPECIFIED TIME - NO LOAD

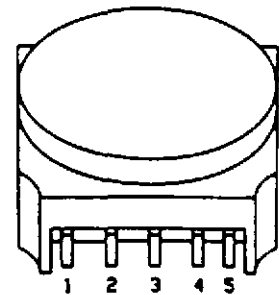

PLANT EXERCISER  
TERMINAL LAYOUT

- OPTION 23D - PLANT EXERCISER  
RUN ENGINE AT SPECIFIED TIME - LOAD

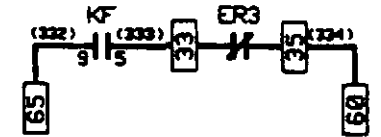

FAILSAFE CIRCUIT

- OPTION 23I = 23D W/FAILSAFE

- OPTION 23J = 23G W/FAILSAFE

- OPTION 23G - PLANT EXERCISER  
RUN ENGINE AT SPECIFIED TIME - LOAD OR NO LOAD  
(SWITCH SELECTABLE)



	ENGINE RUN	BYPASS	LOAD TEST
1 - 2	X		
5 - 6			X
7 - 8	X	X	
9 - 10	X		
11 - 12			X

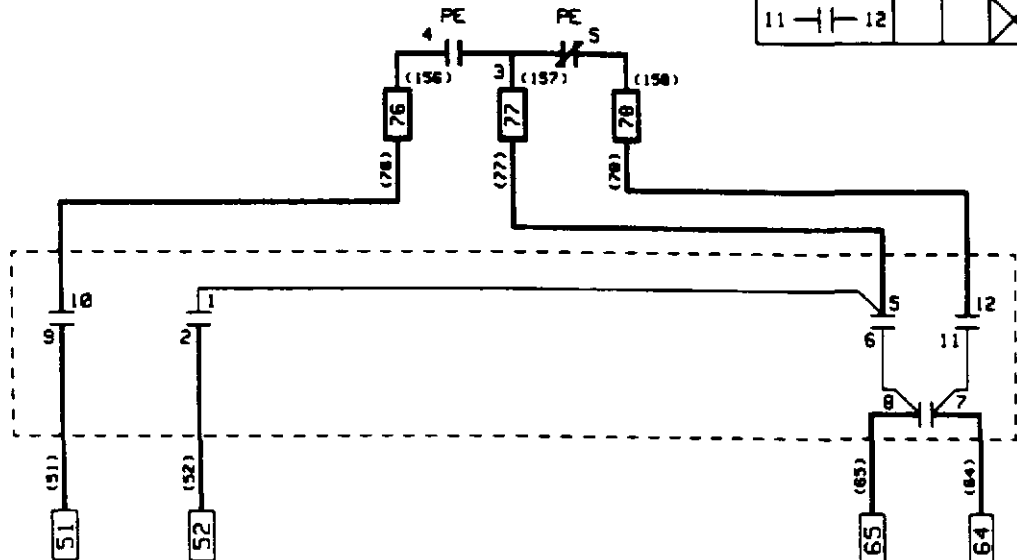

REMOVE JUMPER 64-65

**OPTION 30 - TIME DELAY CRANK LIMITER (TDCL)**  
 INTERRUPTS ENGINE START CIRCUIT IF VOLTAGE DOES NOT APPEAR WITHIN A PRESELECTED TIME

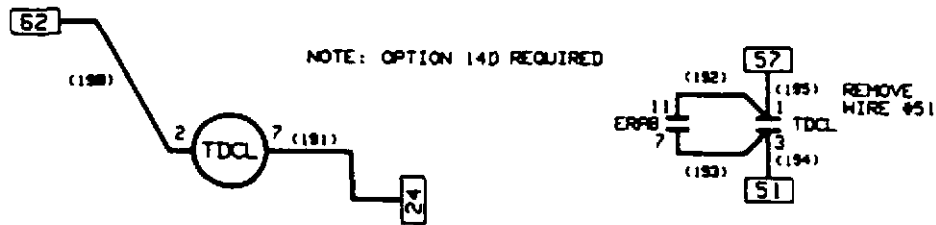

**OPTION 32A - TIME DELAY NEUTRAL (TDNC)**  
 PROVIDES A TIME DELAY IN THE NEUTRAL POSITION WHEN THE LOAD IS TRANSFERRED IN EITHER DIRECTION TO PREVENT EXCESSIVE INRUSH CURRENTS DUE TO OUT-OF-PHASE SWITCHING OF INDUCTIVE LOADS

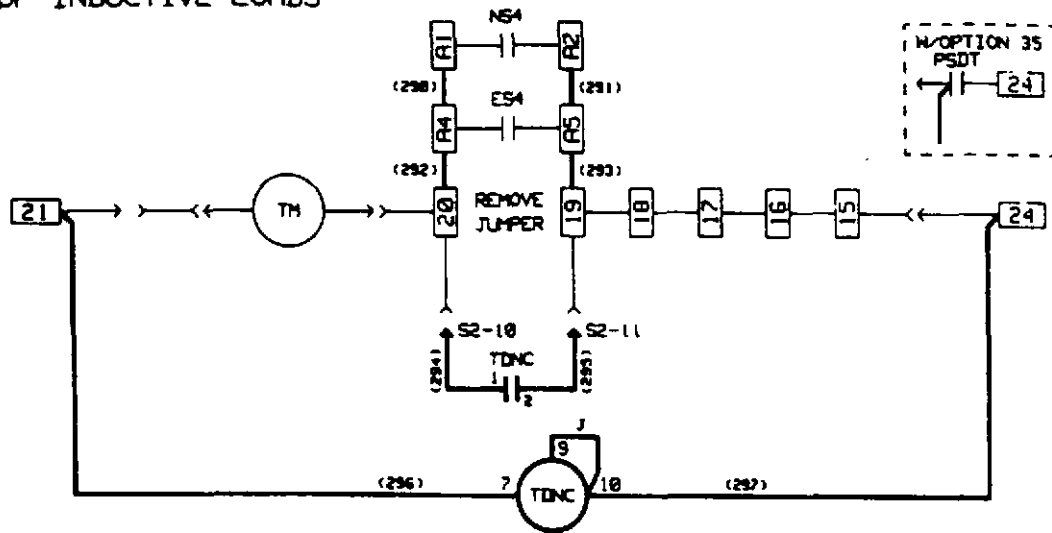

**OPTION 35A - PRETRANSFER SIGNAL DEVICE (PSD)**  
 RELAY CONTACTS CHANGE STATE PRIOR TO TRANSFER WITH PRESET TIME DELAY

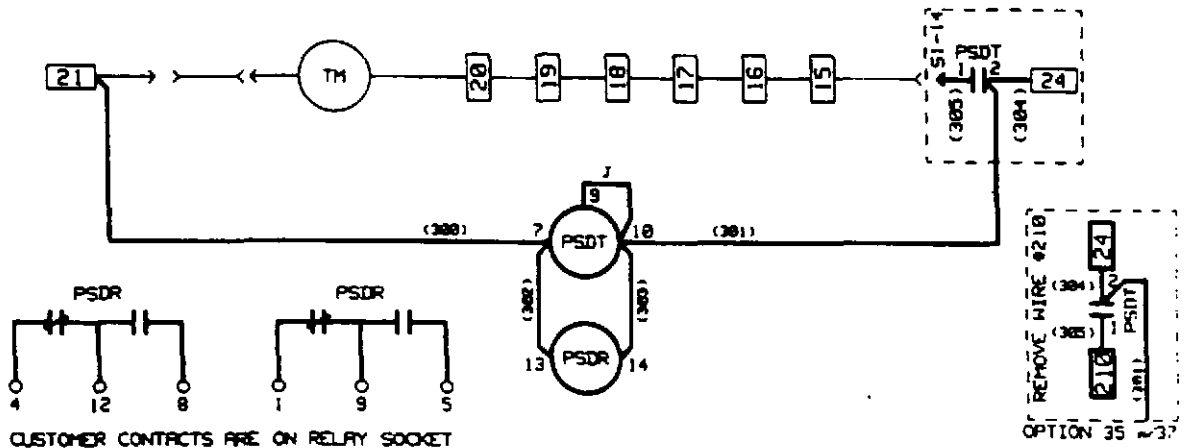

OPTION 28A - INTELLIGENCE CIRCUIT FUSES  
FUSES NON-ESSENTIAL CIRCUITRY ONLY

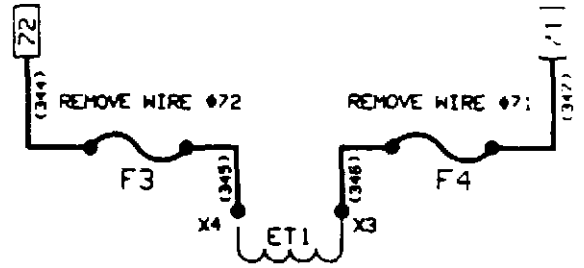
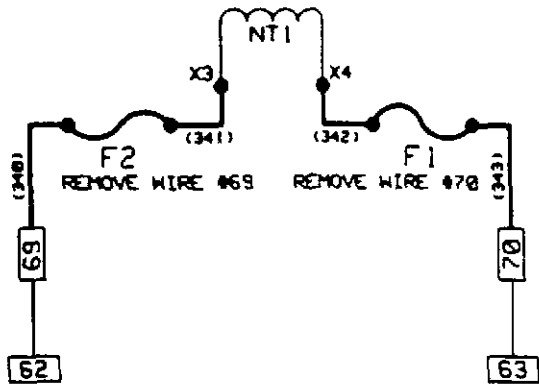

OPTION 33A - SHUNT TRIP  
(NORMAL)

OPTION 33B - SHUNT TRIP  
(EMERGENCY)

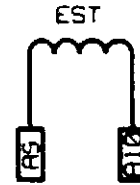
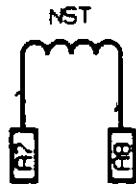

OPTION 29E - MANUAL RETURN TO NORMAL (NMPB)

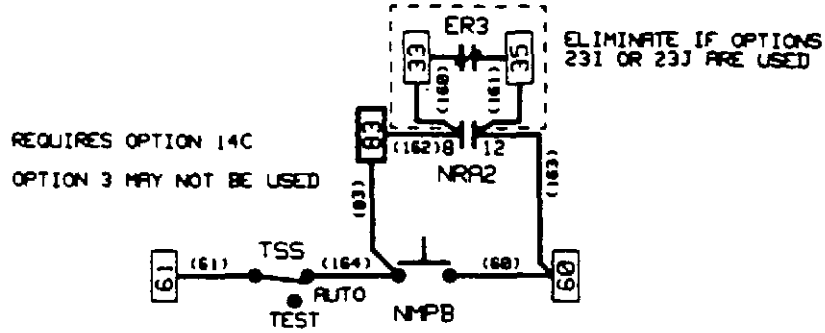

OPTION 29J AUTOMATIC/MANUAL RETURN TO NORMAL

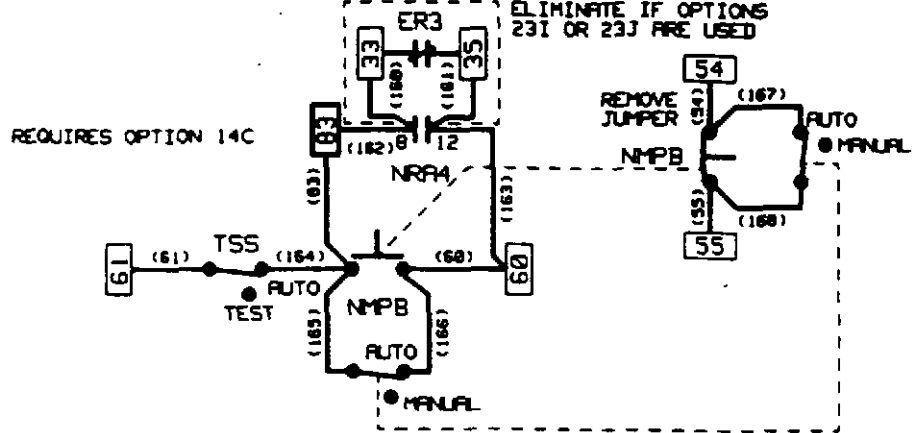

OPTION 29G - AUTOMATIC/MANUAL OPERATION

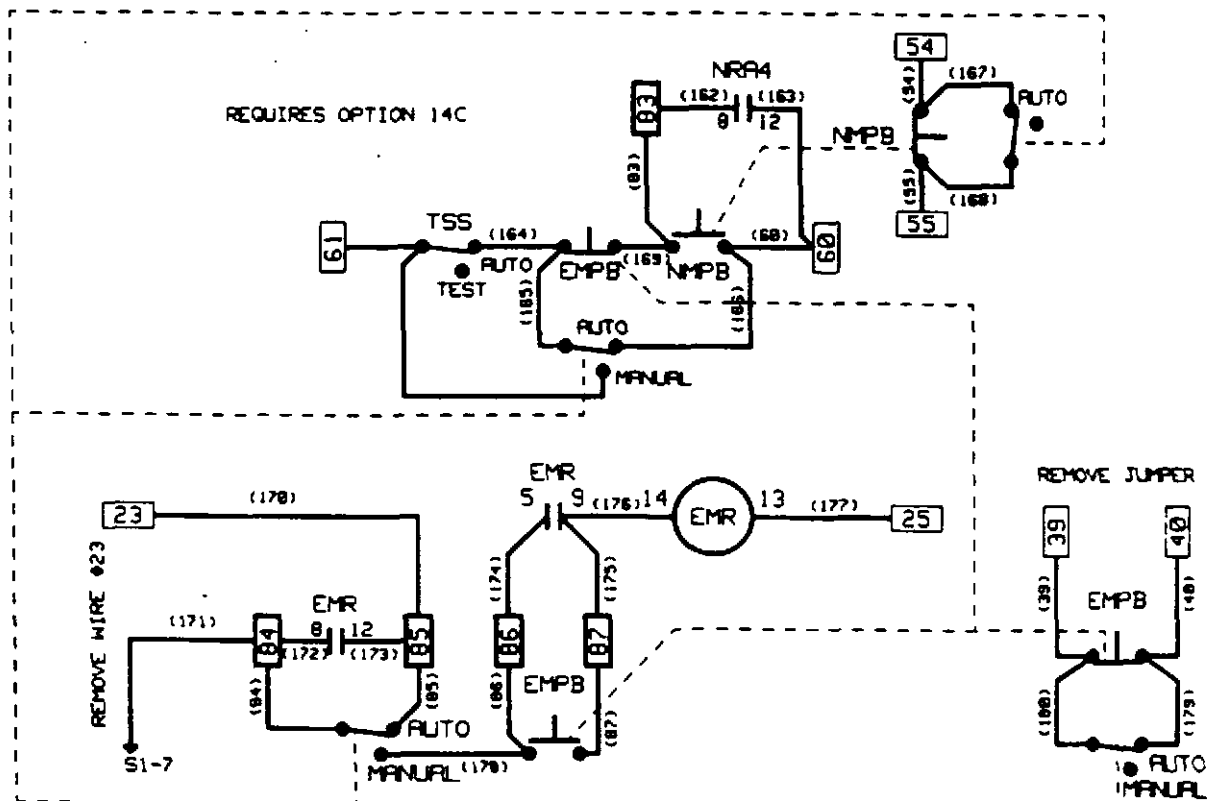

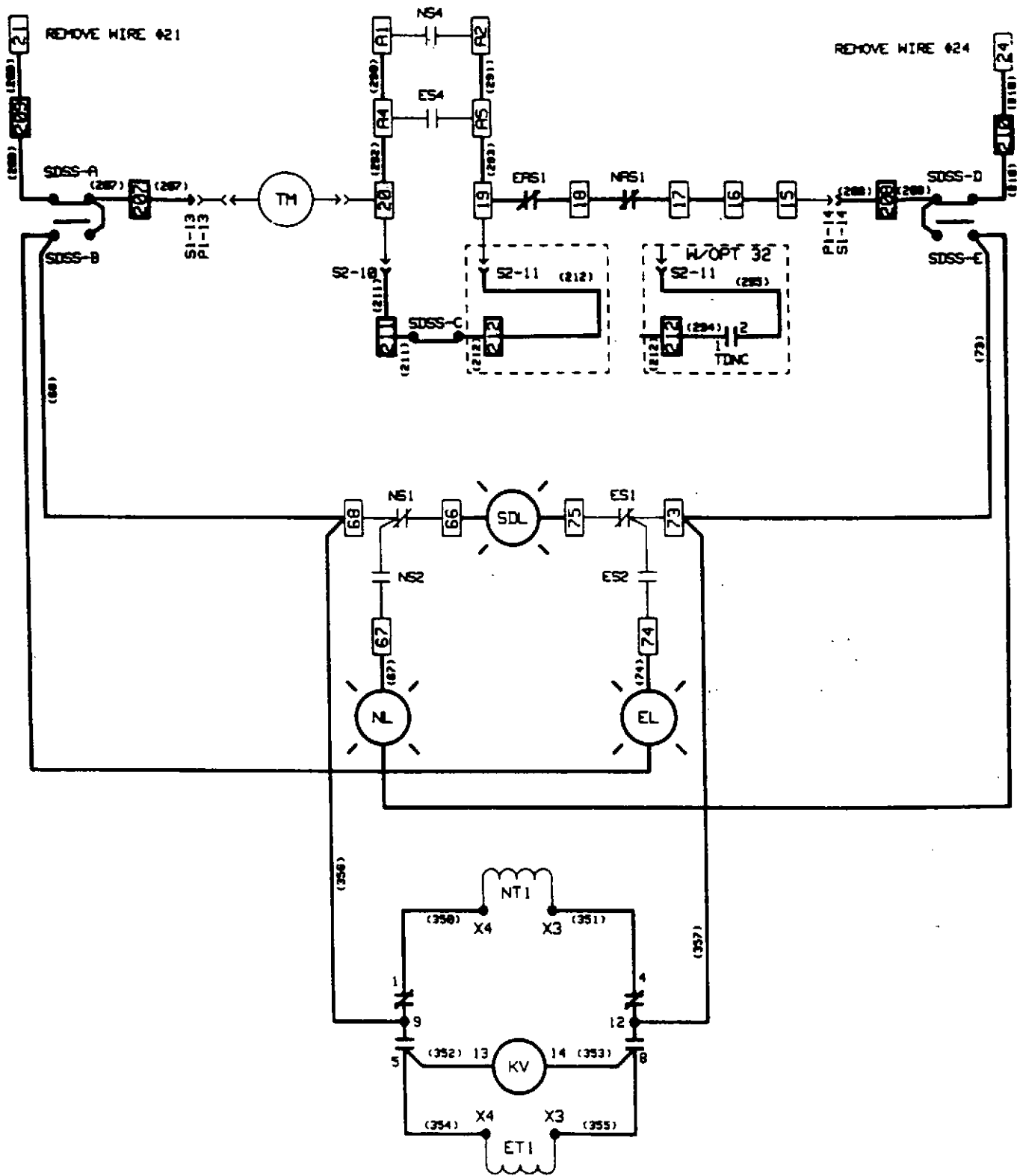

SDSS	A	B	C	D	E
DISCONNECT		X			X
ENERGIZE	X		X	X	

KEY REMOVABLE IN DISCONNECT POSITION

Symbol	Description
AM	Ammeter
Ex	Power Terminal, Emergency Source (x = Terminal Number)
EASx	Emergency Lockout (x = contact number)
EC	Engine Cooloff Relay Coil
ECx	Engine Cooloff Relay Contact (x = contact number)
EL	Emergency Position Indicator Light
ELS	Emergency Limit Switch
EMPB	Emergency Pushbutton for Manual Operation
EMR	Emergency Relay (Manual Operation)
ER	Emergency Relay Coil
ERx	Emergency Relay Contact (x = contact number)
EPA	Emergency Auxiliary Relay Coil
EPAx	Emergency Auxiliary Relay Contact (x = Contact Number)
ETM	Generator Run Time Meter
EST	Emergency Shunt Trip
ESx	Emergency Auxiliary Switch (x = contact number)
ET1	Emergency Transformer (Line Voltage to 120vac - 2 windings)
ET2	Emergency Transformer (120 to 24vac CT)
ET3	Emergency Transformer (Line Voltage to 12vac)
ET4	Emergency Transformer (Line Voltage to 12vac)
EPSS	Four Position Selector Switch (Option 7)
FR	Frequency Meter
Fx	Fuse (x = Fuse Number)
FR	Failsafe Relay
RV	Voting Relay
MSS	Maintenance Selector Switch
NASx	Normal Lockout (x = contact number)
Nx	Power Terminal, Normal (x = Terminal number)
NL	Normal Position Indicator Light
NLS	Normal Limit Switch
NMPB	Normal Pushbutton for Manual Operation
NR	Normal Relay Coil
NRx	Normal Relay Contact (x = contact number)
NRA	Normal Auxiliary Relay Coil
NRAx	Normal Auxiliary Relay Contact (x = contact number)
NST	Normal Shunt Trip
NSx	Normal Auxiliary Switch (x = contact number)
NT1	Normal Transformer (Line Voltage to 120vac - 2 windings)
NT2	Normal Transformer (120 to 24vac CT)
NT3	Normal Transformer (Line Voltage to 12vac)
NT4	Normal Transformer (Line Voltage to 12vac)
Px-y	Plug (x = number, y = Terminal number)
PBEN	Bypass TDEN Pushbutton
PBNE	Bypass TDNE Pushbutton
PBRE	Pushbutton Reset Emergency Trip
PBRN	Reset Normal Breaker Trip Pushbutton
PE	Plant Exerciser
PSDR	Pre-Transfer Signal Device Relay
PSDT	Pre-Transfer Signal Device Timer
PSS	Preferred Source Selector Switch
Sx-y	Socket (x = number, y = Terminal number)
SDL	Service Disconnect Light
SDSS	Service Disconnect Selector Switch
SE	Emergency Source Available Indicator Light
SN	Normal Source Available Indicator Light
Tx	Power Terminal, Load (x = Terminal Number)
TDCL	Time Delay Crank Time Limiter
TDEC	Time Delay Engine Cool Down
TDEN	Time Delay Emergency to Normal
TDES	Time Delay Engine Start
TDNC	Time Delay Neutral
TDNE	Time Delay Normal to Emergency
TE	Emergency Trip Indicator Light
TM	Transfer Motor and Brake
TN	Normal Trip Indicator Light
TPB	Test Pushbutton
TSS	Test Selector Switch
VM	Voltmeter

# **Cutler-Hammer Beaver, PA**

Automatic Transfer Switch

Type **ATSRM** Wiring Diagrams

Cutler-Hammer  
Power Distribution Components Division  
One Tuscarawas Road  
Beaver, PA 15009

Copyright 1995 by Eaton/Cutler-Hammer Inc.  
All Rights Reserved

Version 1.2 10-9-92

# Cutler-Hammer Automatic Transfer Switch Wiring Diagrams

## Directions for Use

The drawing package can be used as a point to point wiring diagram for maintenance and diagnostic purposes for Solid State Logic SPB Transfer Switches, all voltages.

This document contains the following wiring information:

**Page 1**

Basic Solid State Intelligence Panel Wiring exclusive of added option functions

**Page 2**

Power Switching Panel basic wiring exclusive of added option functions.

**Pages 3 - 18**

Wiring for optional functions

**Page 19**

Legend Sheet describing symbols used throughout this document

Note: Unnumbered sheets may be added to this document on specific occasions to illustrate custom options additions per order instructions.

All transfer switch units will be standardly wired as indicated by Pages 1, and 2. The Intelligence Panel and Power Panel are interconnected via keyed plug/socket connectors (P1-S1/P2-S2). Your specific unit may be equipped with certain optional functions as noted which require additional wiring as shown on pages 3 - 18.

Wiring for optionally added functions will typically interface with the basic unit wiring (Pages 1-2) which should be used as the base reference.

Note: **BOLD** lines on option wiring indicate components and wiring added to the basic wiring diagram to accomplish that specific option function.

# Cutler-Hammer Automatic Transfer Switch

## Standard Features

### **Test Pushbutton**

Simulates a power failure in the logic. Will cause the Generator to start, and load to transfer to the Emergency Source.

### **Undervoltage Protection on NORMAL (All phases)**

Monitors the voltage on the NORMAL Source for an undervoltage condition. Should the voltage drop below a preset Dropout, the generator is started and transfer to the EMERGENCY Source takes place.

### **Engine Start Contact**

Contact that provides a closure to Engine Controller when the NORMAL Source fails.

### **Logic Disconnect**

Plugs provided to disconnect the logic circuitry for maintenance purposes.

### **Auxiliary Contacts**

Auxiliary contacts integral to the switching devices rated at 120 VAC, 10 amps. These may be applied for customer use, and may be applied to certain customer specified options.

### **Fully Rated Neutral**

A fully rated solid neutral is supplied on all two and three pole switches. All four pole switches are supplied with switched neutral contacts of identical construction and rating as the power poles.

# SPB ATS INTELLIGENCE PANEL

NOTE A

NOTE A:  
 TRANSFORMERS NT3, NT4 AND WIRES 183, 188 USED FOR 3 PHASE NORMAL SENSING  
 TRANSFORMERS ET3, ET4 AND WIRES 114, 116 USED FOR 3 PHASE EMERGENCY SENSING (OPTION SF AND/OR SC)

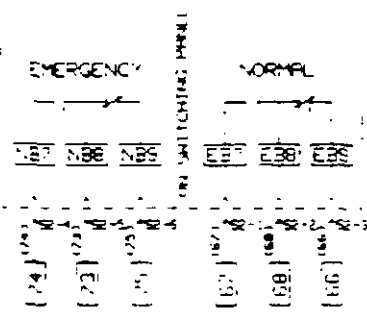
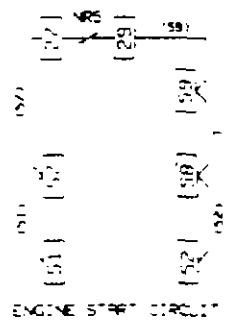
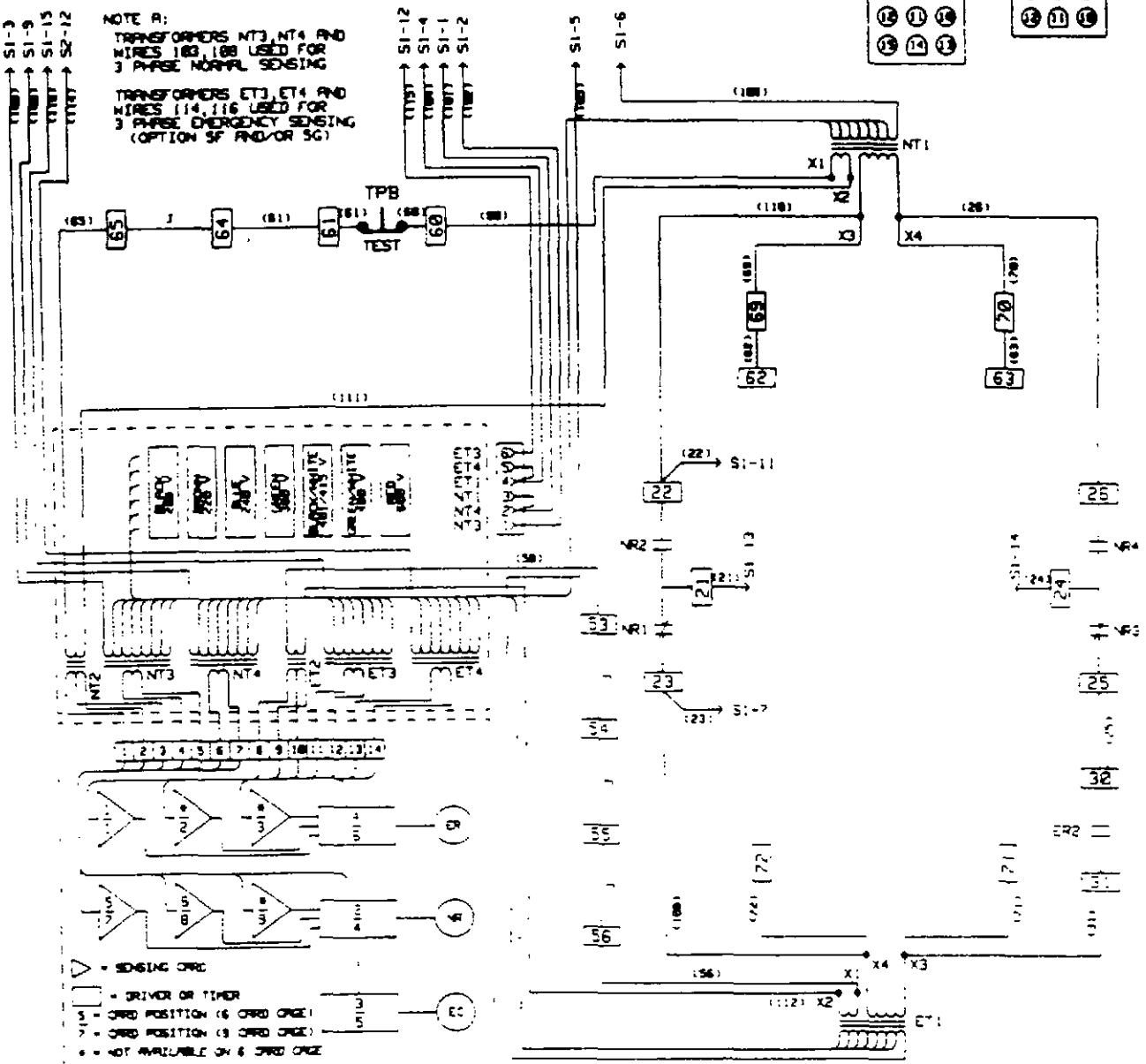
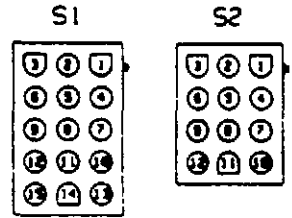

# SPB POWER SWITCHING PANEL (FIXED MOUNT)

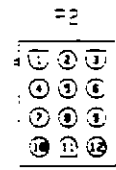
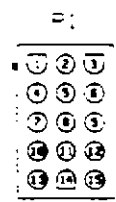
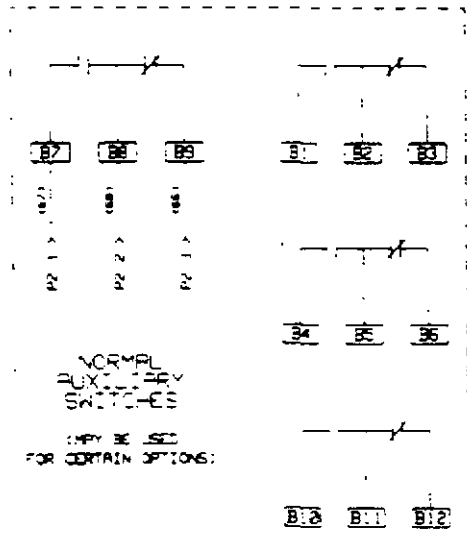
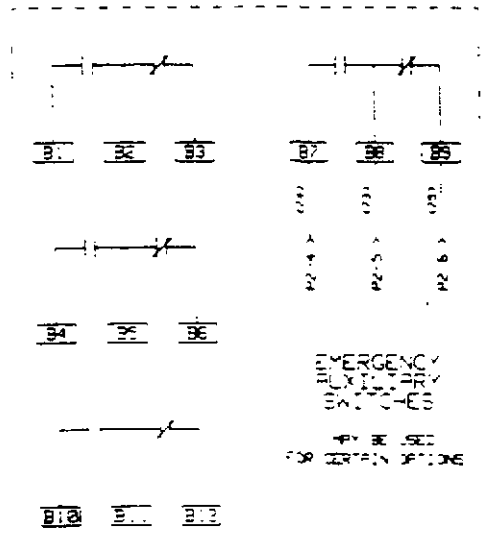
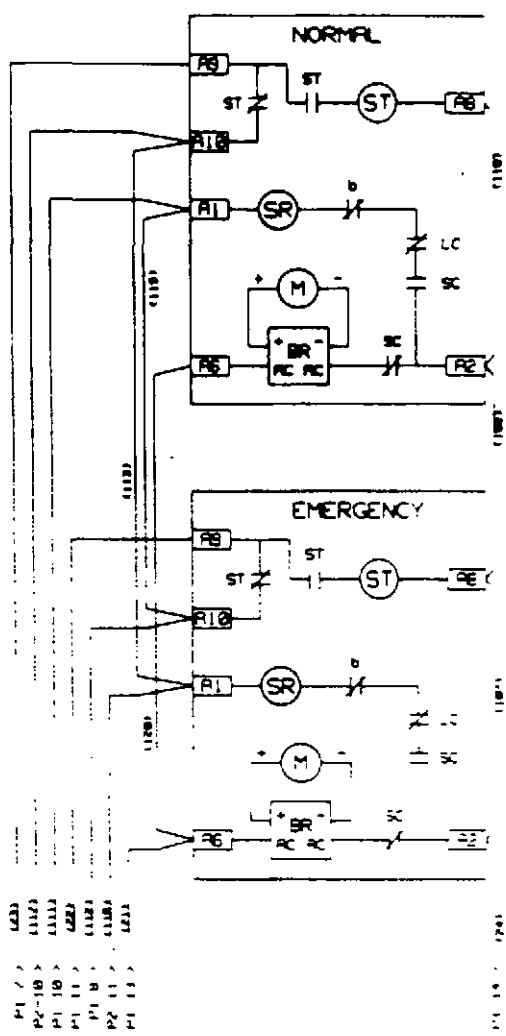
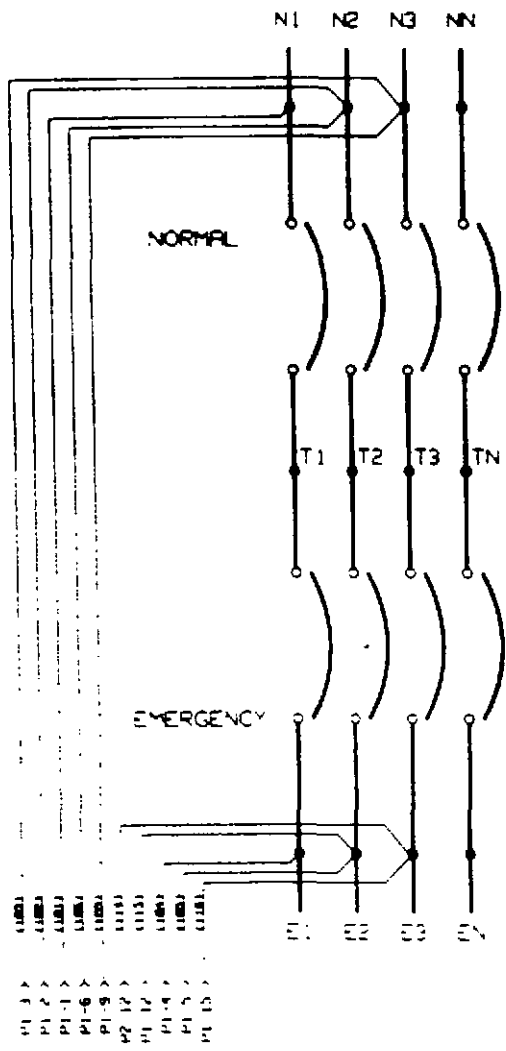

6 POSITION CARD CAGE

NORMAL		ENG	EMERGENCY		
1	2	3	4	5	6
UNDERVOLTAGE	STD	DRIVER (OPTION 3)	BLANK (OPTION 4)	DRIVER (OPTION 1)	BLANK (OPTION 5)
		BLANK (OPTION 3)	DRIVER (OPTION 4)	BLANK (OPTION 1)	BLANK (OPTION 5)

9 POSITION CARD CAGE

NORMAL			ENG	EMERGENCY				
1	2	3	4	5	6	7	8	9
UNDERVOLTAGE	STD	BLANK (OPTION 26)	BLANK (OPTION 26)	DRIVER (OPTION 3)	BLANK (OPTION 4)	DRIVER (OPTION 1)	BLANK (OPTION 5)	BLANK (OPTION 5)
		BLANK (OPTION 26)	DRIVER (OPTION 3)	BLANK (OPTION 4)	DRIVER (OPTION 1)	BLANK (OPTION 5)	BLANK (OPTION 5)	BLANK (OPTION 5)

OPTION 1 - TIME DELAY NORMAL TO EMERGENCY (TDNE)

6 POSITION CARD CAGE  
REPLACE DRIVER CARD IN POSITION 4  
WITH TIMER CARD

9 POSITION CARD CAGE  
REPLACE DRIVER CARD IN POSITION 6  
WITH TIMER CARD

OPTION 3 - TIME DELAY EMERGENCY TO NORMAL (TDEN)

6 POSITION CARD CAGE  
REPLACE DRIVER CARD IN POSITION 2  
WITH TIMER CARD

9 POSITION CARD CAGE  
REPLACE DRIVER CARD IN POSITION 4  
WITH TIMER CARD

OPTION 4 - TIME DELAY ENGINE COOLOFF (TDEC)

6 POSITION CARD CAGE  
REPLACE BLANK CARD IN POSITION 3  
WITH TIMER CARD  
ADD EC RELAY TO MOTHERBOARD

9 POSITION CARD CAGE  
REPLACE BLANK CARD IN POSITION 5  
WITH TIMER CARD  
ADD EC RELAY TO MOTHERBOARD

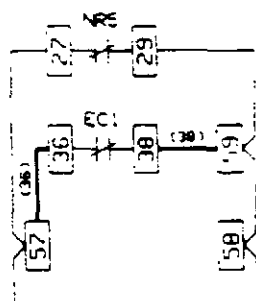

OPTION 4 ONLY

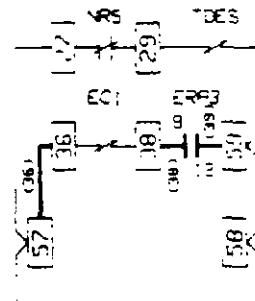

OPTION 4 WITH 2 \*\*  
\*\* REQUIRES OPTION 14B

OPTION 5 - EMERGENCY SENSING (OV,OV,LF,OF)

6 POSITION CARD CAGE  
REPLACE BLANK CARD IN POSITION 5 OR 6  
WITH APPROPRIATE SENSING CARD

9 POSITION CARD CAGE  
REPLACE BLANK CARD IN POSITION 7, 8 OR 9  
WITH APPROPRIATE SENSING CARD

OPTION 26 - NORMAL SENSING (OV,LF,OF)

6 POSITION CARD CAGE  
NOT AVAILABLE

9 POSITION CARD CAGE  
REPLACE BLANK CARD IN POSITION 3 OR 4  
WITH APPROPRIATE SENSING CARD

\* UNDERVOLTAGE SENSING ON NORMAL IS STANDARD

OPTION 2 - TIME DELAY ENGINE START (TDES)

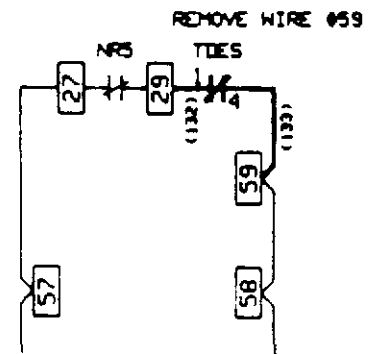
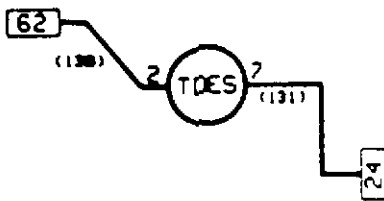

OPTION 6D - TEST SELECTOR (TSS)

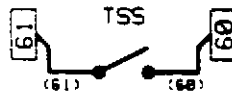

REPLACES STANDARD TEST PUSH-BUTTON

OPTION 6H - FOUR POSITION SELECTOR SWITCH (FPSS)

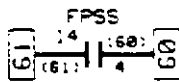

REPLACES STANDARD TEST SELECTOR SWITCH

FPSS	1,9	1,11	1,4	1,13	1,17
TEST	1,8	1,12	1,5	1,14	1,18
AUTO					
OFF					
ENG. RUN					

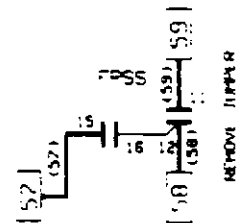
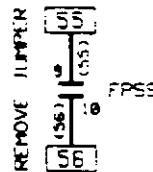
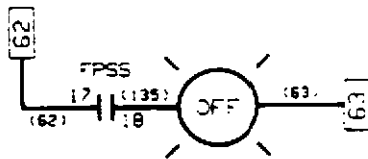

OPTION 8C - BYPASS TDES TIMER (PBEN)

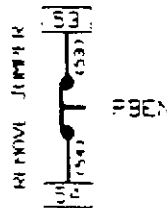

OPTION 8D - BYPASS TONE TIMER (PBNE)

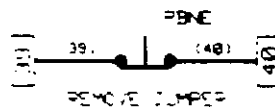

OPTION 9 - MAINTENANCE SELECTOR SWITCH

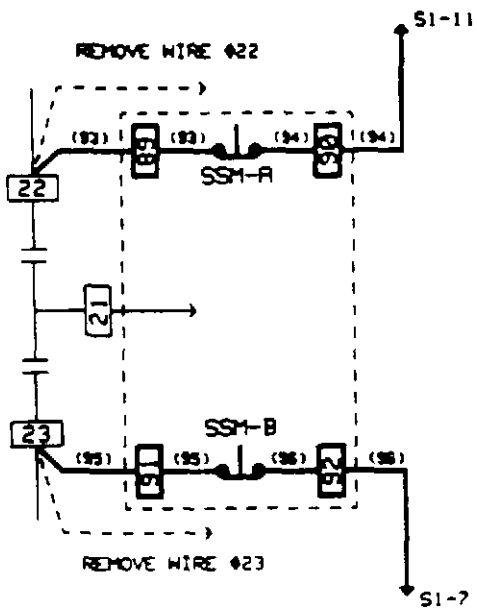

- OPTION 12C - NORMAL POSITION LIGHT (NL)  
INDICATES LOAD IS CONNECTED TO NORMAL

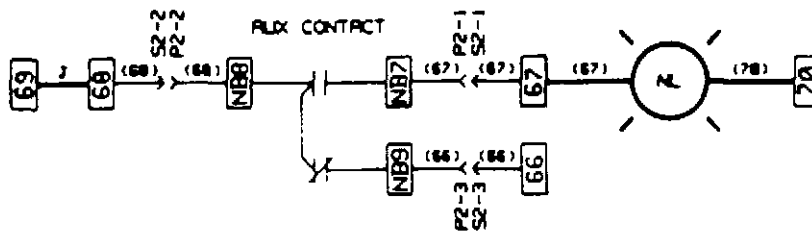

- OPTION 12D - EMERGENCY POSITION LIGHT (EL)  
INDICATES LOAD IS CONNECTED TO EMERGENCY

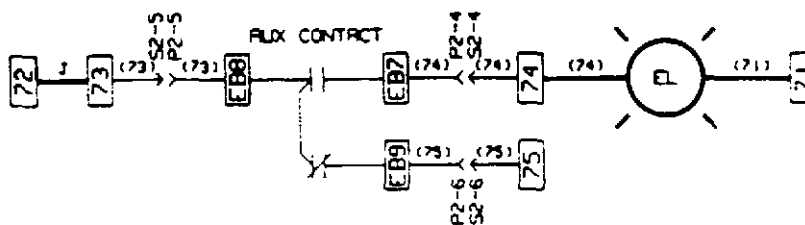

- OPTION 12G - NORMAL SOURCE LIGHT (SN)  
INDICATES NORMAL SOURCE AVAILABLE

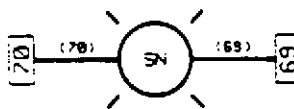

- OPTION 12H - EMERGENCY SOURCE LIGHT (SE)  
INDICATES EMERGENCY SOURCE AVAILABLE

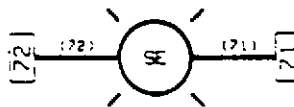

OPTION 14C - NORMAL AUXILIARY RELAY (NRA)  
 PROVIDES ADDITIONAL RELAY CONTACTS ON NORMAL

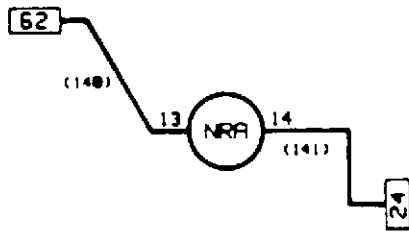

NOTE: CUSTOMER CONTACTS ARE ON RELAY SOCKET  
 SEE SOCKET DIAGRAM BELOW

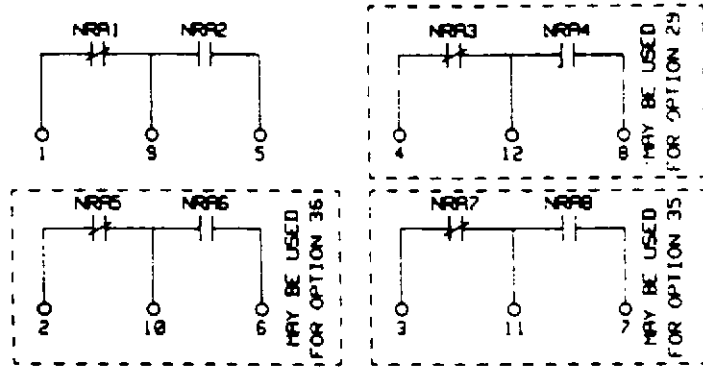

OPTION 14D - EMERGENCY AUXILIARY RELAY (ERA)  
 PROVIDES ADDITIONAL RELAY CONTACTS ON EMERGENCY



NOTE: CUSTOMER CONTACTS ARE ON RELAY SOCKET  
 SEE SOCKET DIAGRAM BELOW

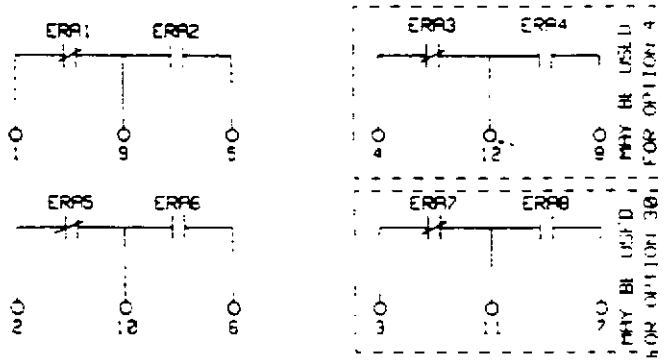

NRA - ERA SOCKET DIAGRAM

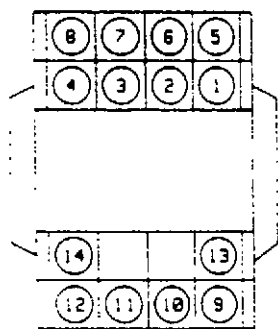

# OPTION 16 - SPB DIGITRIP

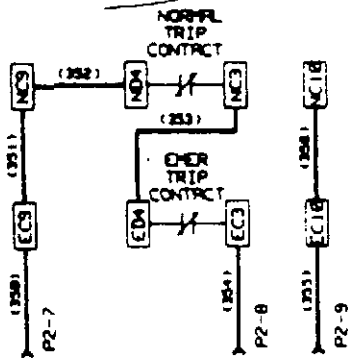

DIGITRIPS (BOTH)

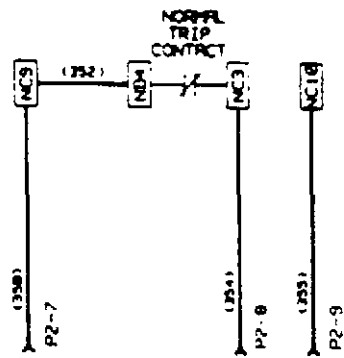

DIGITRIP (NORMAL ONLY)

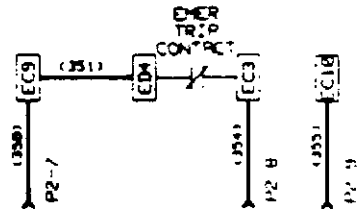

DIGITRIP (EMERGENCY ONLY)

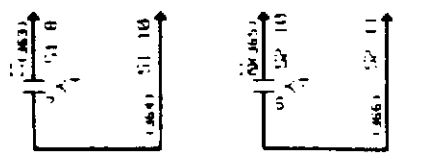
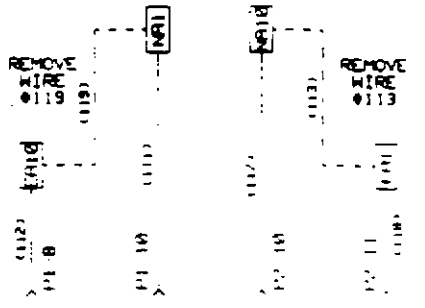
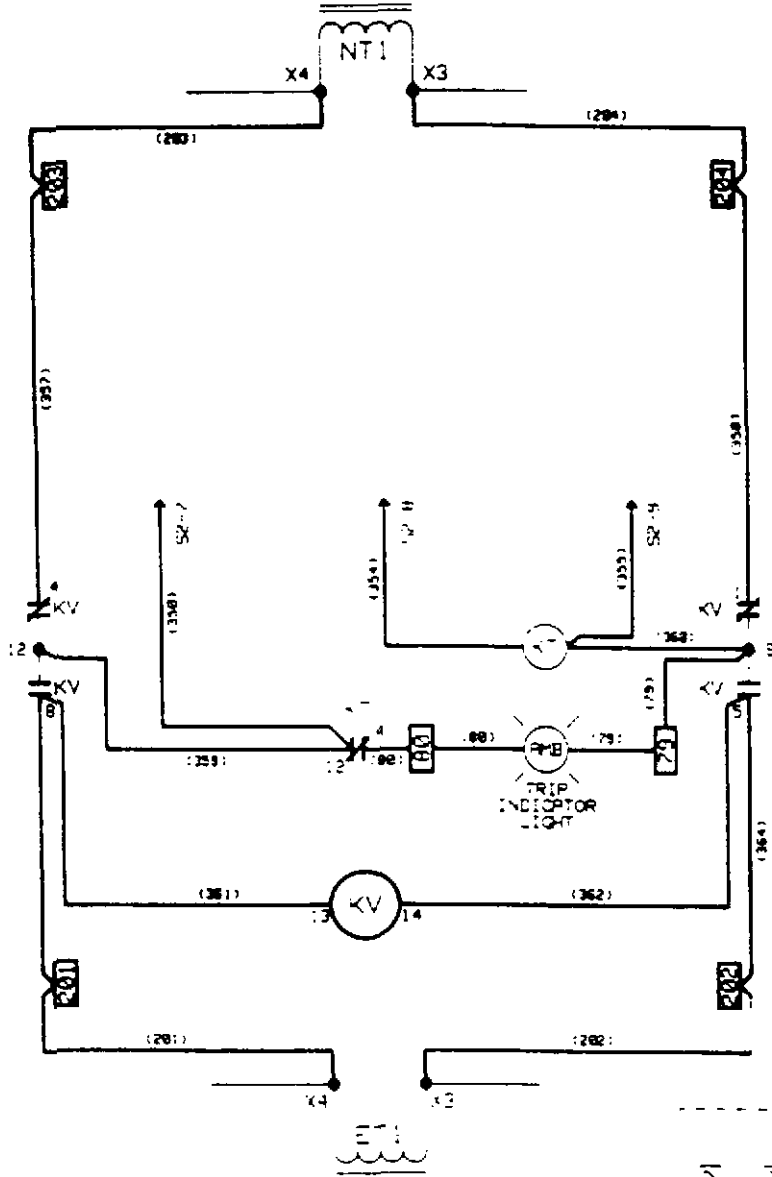

OPTION 16 ONLY

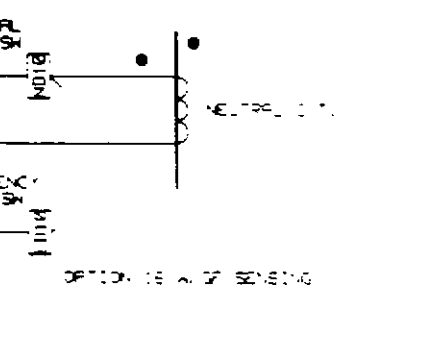
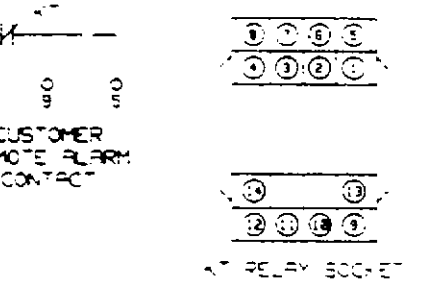

OPTION 18E - VOLTMETER

	HANDLE POSITION					
	NORMAL			EMERGENCY		
	1-3	2-3	1-2	1-2	2-3	1-3
1 — 2				X	X	X
3 — 4	X		X			
5 — 6					X	
7 — 8		X				
9 — 10						X
11 — 12	X					
13 — 14				X	X	
15 — 16		X	X			

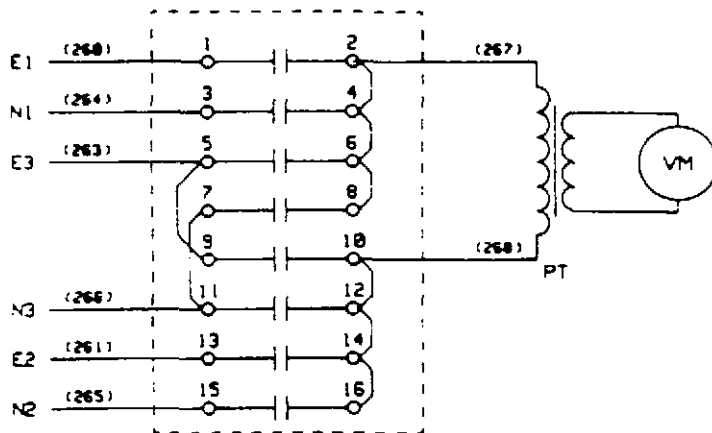

OPTION 18F - AMMETER

	HANDLE POSITION			
	OFF	1	2	3
1 — 2	X	X	X	X
3 — 4	X	X	X	X
5 — 6	X	X	X	X
7 — 8	X	X	X	X
9 — 10	X	X	X	X
11 — 12	X	X	X	X

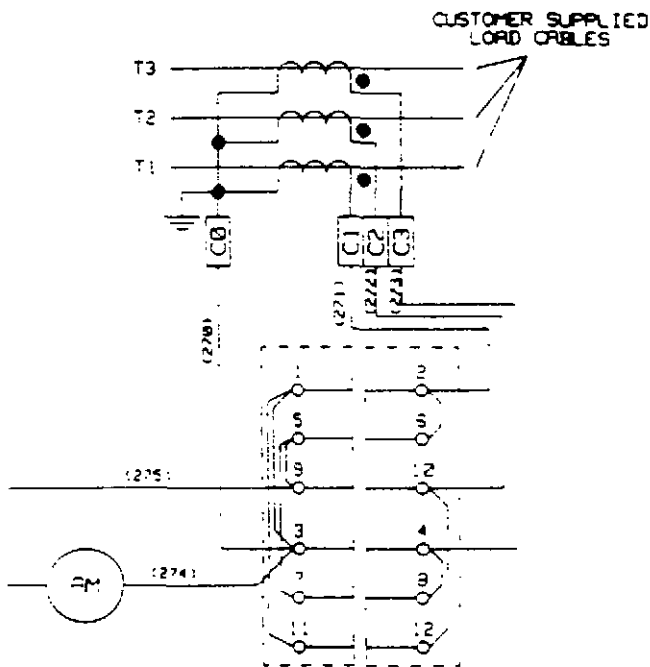

OPTION 18G - FREQUENCY METER

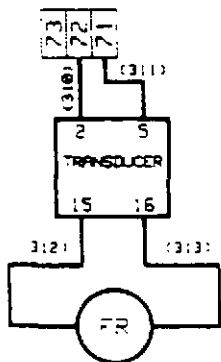

OPTION 18H - RUNNING TIME METER

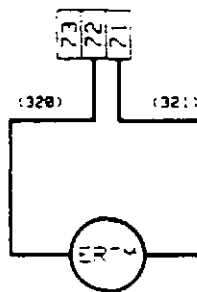

OPTION 23C - PLANT EXERCISER  
 RUN ENGINE AT SPECIFIED TIME  
 (NO LOAD)

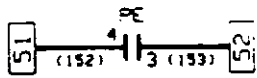

PE TERMINAL BLOCK

OPTION 23I = 23D W/FAILSAFE  
 OPTION 23J = 23G W/FAILSAFE

OPTION 23D - PLANT EXERCISER  
 RUN ENGINE AT SPECIFIED TIME  
 (LOAD)

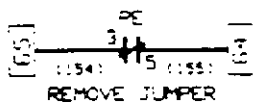

FAILSAFE CIRCUIT

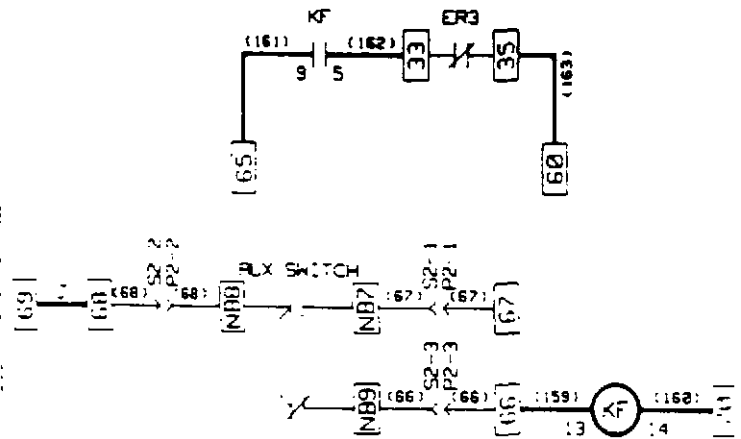

OPTION 23G - PLANT EXERCISER  
 RUN ENGINE AT SPECIFIED TIME  
 (SWITCH SELECTABLE  
 LOAD OR NO LOAD)

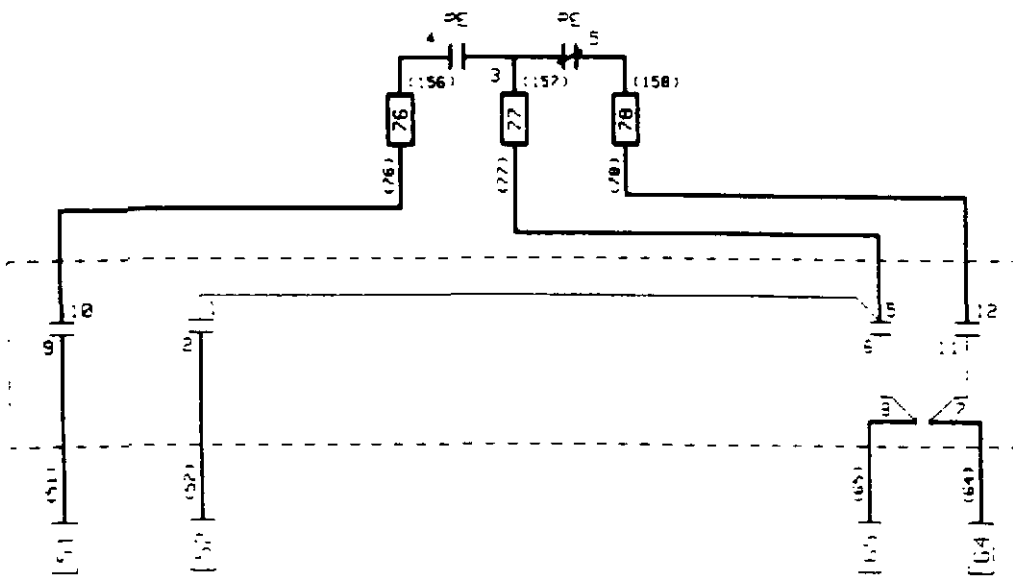

REMOVE JUMPER 54-55

	ENGINE RUN	BYPASS
1	2	X
5	5	X
7	8	X
9	10	X
11	12	X

OPTION 28A - INTELLIGENCE CIRCUIT FUSES  
FUSES NON-ESSENTIAL CIRCUITRY ONLY

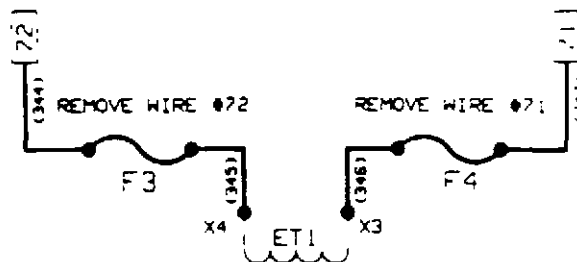
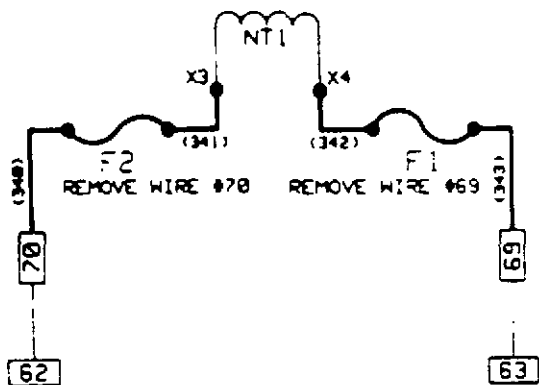

OPTION 30 - TIME DELAY CRANK LIMITER (TDCL)  
INTERUPTS ENGINE START CIRCUIT IF VOLTAGE DOES NOT APPEAR WITHIN A PRESELECTED TIME

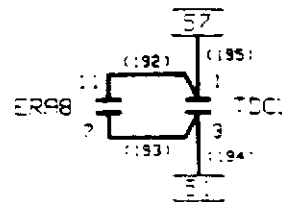
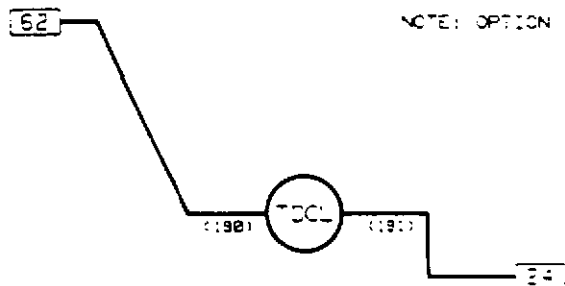

OPTION 31B - PLURIBUS INTELLIGENCE BUS SWITCH  
PLURIBUS SWITCH TO BE CONNECTED TO EMERGENCY

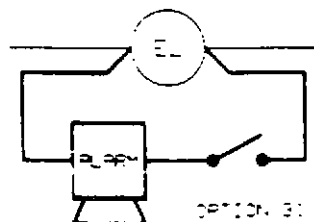
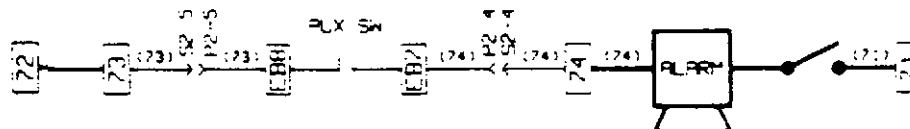

OPTION 29E - MANUAL RETURN TO NORMAL (NMPB)

REQUIRES OPTION 14C  
 OPTION 3 MAY NOT BE USED

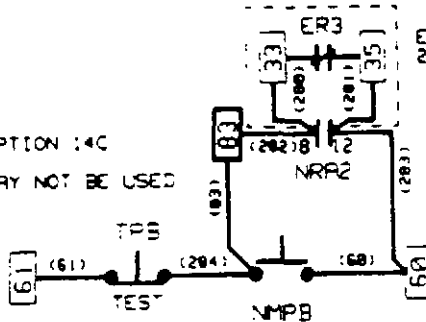

ELIMINATE IF OPTIONS 23I OR 23J ARE USED

OPTION 29J AUTOMATIC/MANUAL RETURN TO NORMAL

REQUIRES OPTION 14C

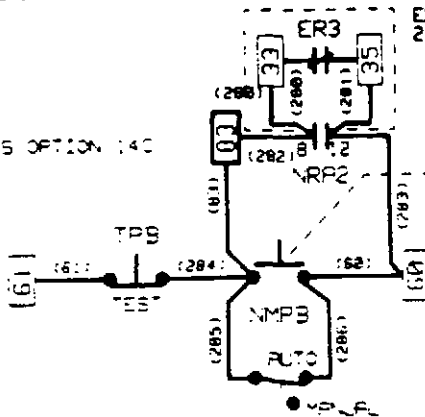

ELIMINATE IF OPTIONS 23I OR 23J ARE USED

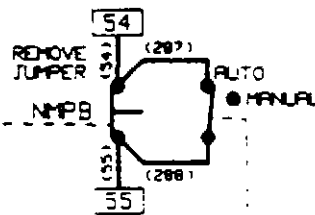

OPTION 29G - AUTOMATIC/MANUAL OPERATION

REQUIRES OPTION 14C

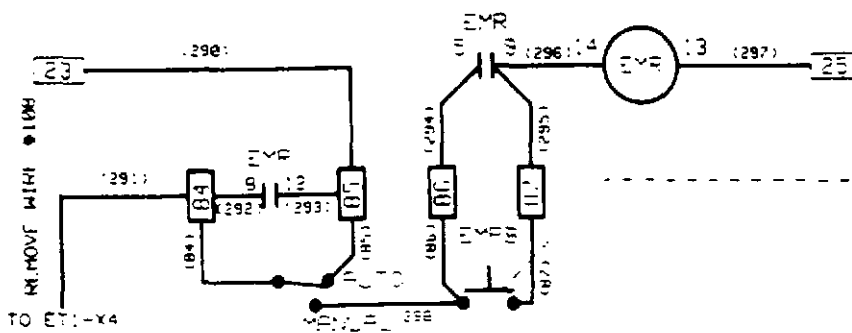
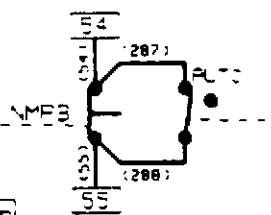
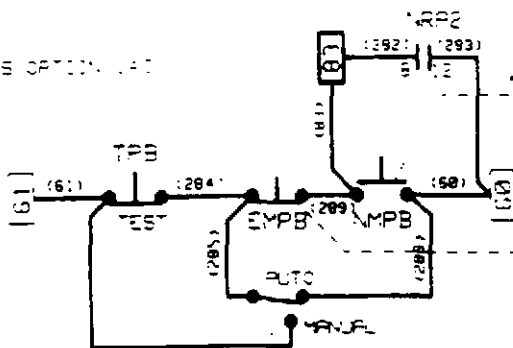

REMOVE JUMPER

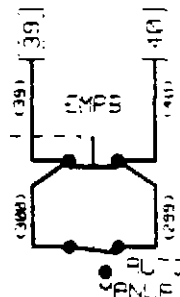



# OPTION 35 - PRETRANSFER SIGNAL DEVICE

(OPTION 14 REQUIRED)

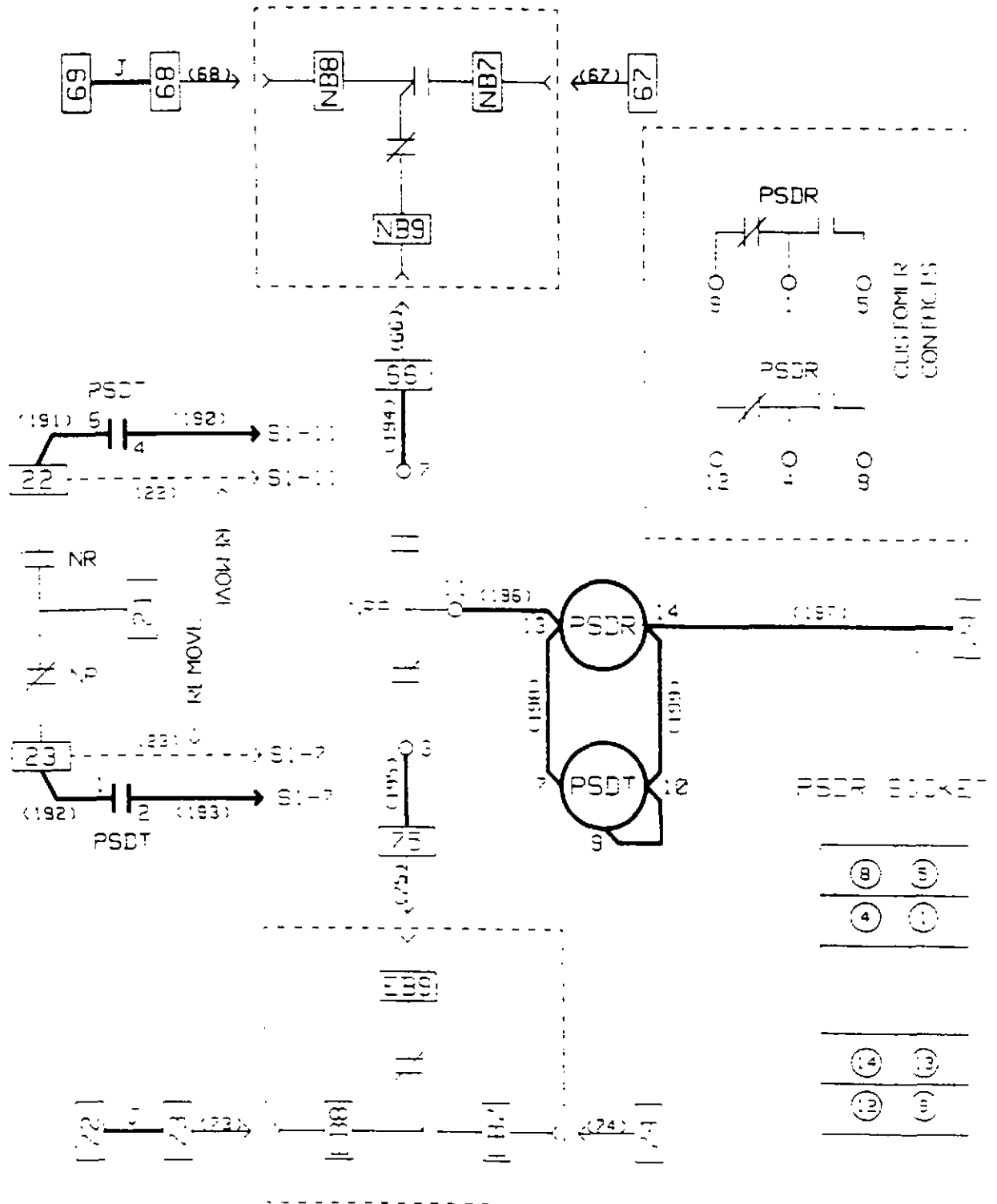



OPTION 32 - TIME DELAY NEUTRAL

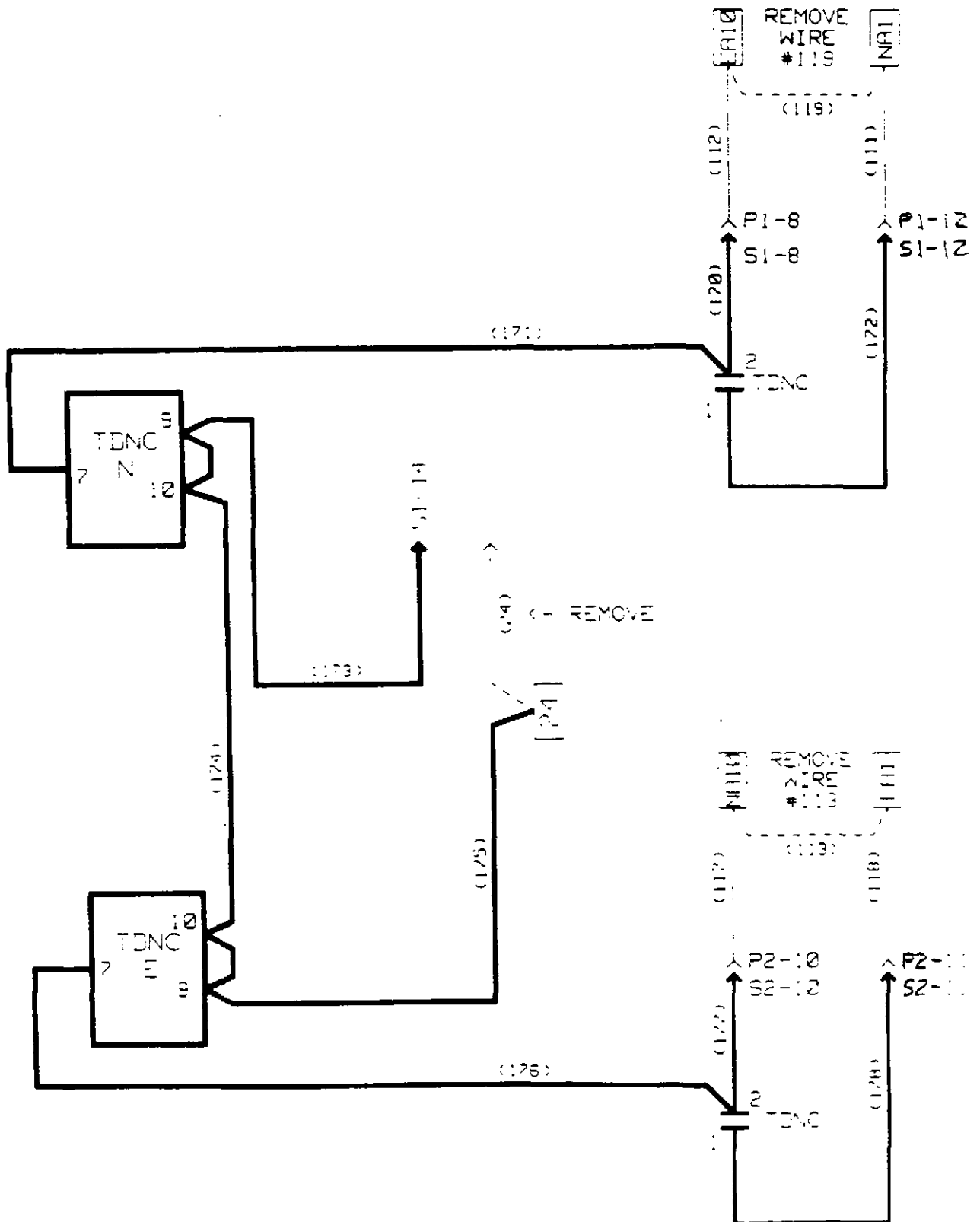



# OPTION 35 - LOAD SHED

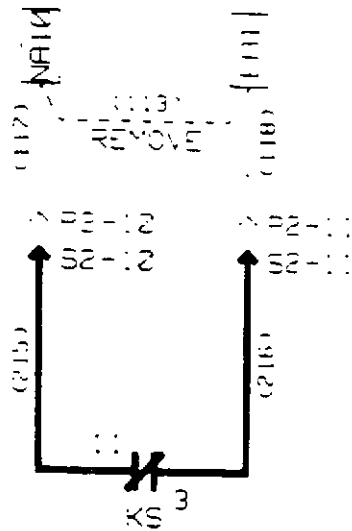
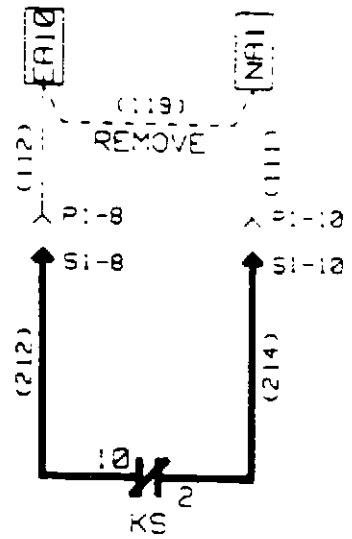
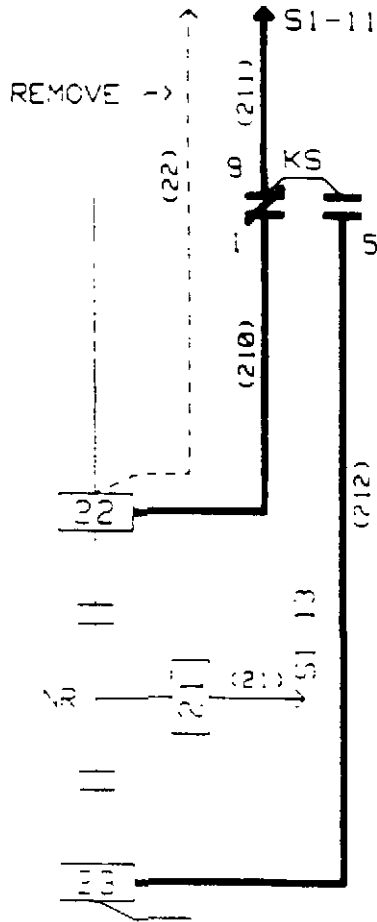

48 RELAY SOCKET

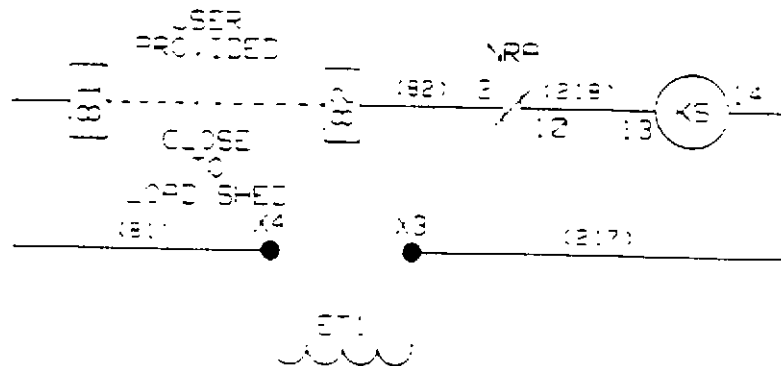
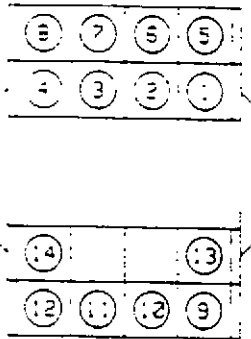

OPTION 37 - SERVICE ENTRANCE  
(MUST USE OPTION 16)

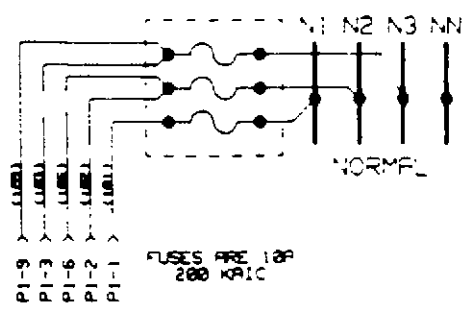

KV IS PROVIDED  
BY OPTION 16

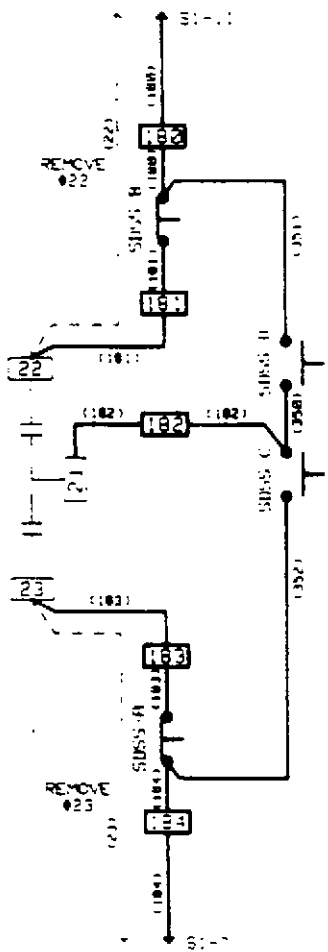
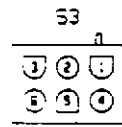
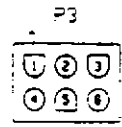
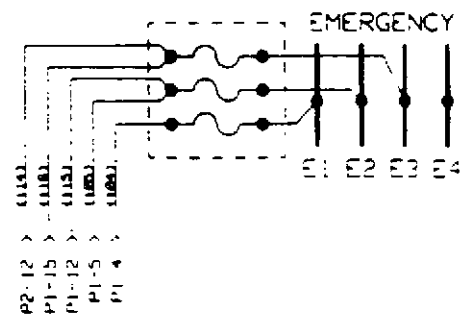
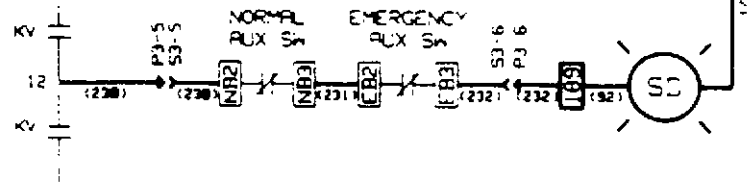

SERVICE  
DISCONNECT IN BOTH DIRECTION  
SERV SW  
DISCONNECT X X  
ENERGIZE X X X X  
KEY LOCKED  
KEY REMOVABLE  
IN "DISCONNECTED" POSITION

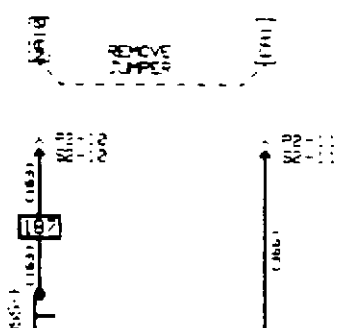
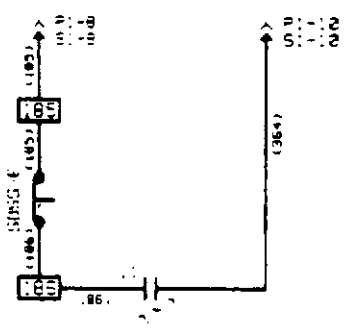
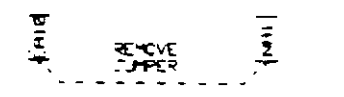

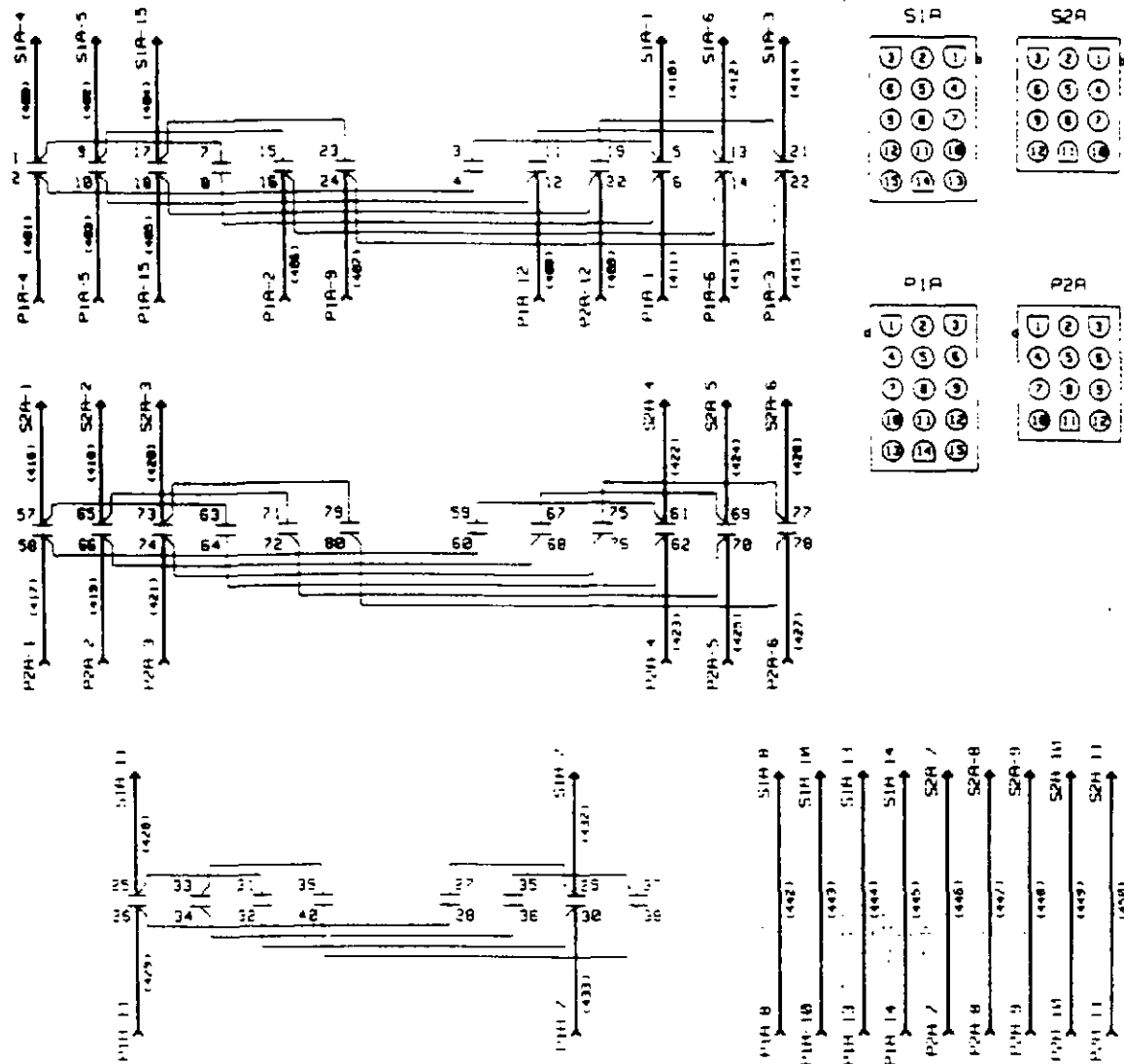

PREFERRED SOURCE SELECTOR SWITCH	1-2	3-4	5-6	7-8	9-10	11-12	13-14	15-16	17-18	19-20	21-22	23-24	25-26	27-28	29-30	31-32	33-34	35-36	37-38	39-40	41-42	43-44	47-48	49-50	51-52	53-56	57-58	59-60	61-62	63-64	65-66	67-68	69-70	71-72	73-74	75-76	77-78	79-80		
NORMAL	X																																							
EMERGENCY	X																																							

(H) PART NO. 658B730-02

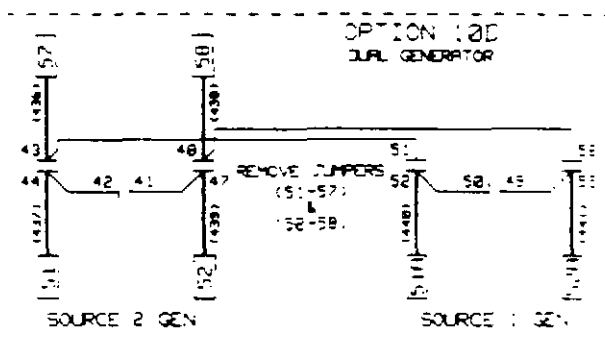
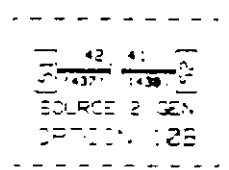
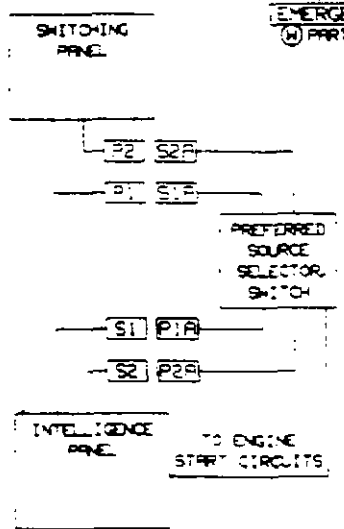

Westinghouse SPB Automatic Transfer Switch  
Legend for Wiring Diagram Symbols

Symbol	Description
AM	Ammeter
Ex	Power Terminal, Emergency Source (x = Terminal Number)
EASx	Emergency Lockout (x = contact number)
EC	Engine Cooloff Relay Coil
ECx	Engine Cooloff Relay Contact (x = contact number)
EL	Emergency Position Indicator Light
EMPB	Emergency Pushbutton for Manual Operation
EMR	Emergency Relay (Manual Operation)
ER	Emergency Relay Coil
ERx	Emergency Relay Contact (x = contact number)
ERA	Emergency Auxiliary Relay Coil
ERAx	Emergency Auxiliary Relay Contact (x = Contact Number)
ERTM	Generator Run Time Meter
ESx	Emergency Auxiliary Switch (x = contact number)
ET1	Emergency Transformer (Line Voltage to 120vac - 2 windings)
ET2	Emergency Transformer (120 to 24vac CT)
ET3	Emergency Transformer (Line Voltage to 12vac)
ET4	Emergency Transformer (Line Voltage to 12vac)
EPSS	Four Position Selector Switch (Option 6H)
FR	Frequency Meter
Fx	Fuse (x = Fuse Number)
KF	Failsafe Relay
KS	Load Shed Relay
KT	Trip Relay (Used w/Option 16)
KV	Voting Relay
MSS	Maintenance Selector Switch
NASx	Normal Lockout (x = contact number)
Nx	Power Terminal, Normal (x = Terminal number)
NL	Normal Position Indicator Light
NMPB	Normal Pushbutton for Manual Operation
NR	Normal Relay Coil
NRx	Normal Relay Contact (x = contact number)
NRA	Normal Auxiliary Relay Coil
NRAx	Normal Auxiliary Relay Contact (x = contact number)
NSx	Normal Auxiliary Switch (x = contact number)
NT1	Normal Transformer (Line Voltage to 120vac - 2 windings)
NT2	Normal Transformer (120 to 24vac CT)
NT3	Normal Transformer (Line Voltage to 12vac)
NT4	Normal Transformer (Line Voltage to 12vac)
Px-y	Plug (x = number, y = Terminal number)
PBEN	Bypass TDEN Pushbutton
PBNE	Bypass TDNE Pushbutton
PBRE	Pushbutton Reset Emergency Trip
PBRN	Reset Normal Breaker Trip Pushbutton
PE	Plant Exerciser
PSDR	Pre-transfer Signal Device Relay
PSDT	Pre-transfer Signal Device Timer
PSS	Preferred Source Selector Switch
Sx-y	Socket (x = number, y = Terminal number)
SDL	Service Disconnect Light
SDSS	Service Disconnect Selector Switch
SD	Services Disconnected Light
SE	Emergency Source Available Indicator Light
SN	Normal Source Available Indicator Light
Tx	Power Terminal, Load (x = Terminal Number)
TDCL	Time Delay Crank Time Limiter
TDEC	Time Delay Engine Cool Down
TDEN	Time Delay Emergency to Normal
TDES	Time Delay Engine Start
TDNC	Time Delay Neutral
TDNE	Time Delay Normal to Emergency
TE	Emergency Trip Indicator Light
TM	Transfer Motor and Brake
TN	Normal Trip Indicator Light
TPB	Test Pushbutton
TSS	Test Selector Switch
VM	Voltmeter

# **Automatic Transfer Switch Wiring Diagrams**

**Catalog Number ATSRD Only  
Solid State Transfer Switch**

**Shop Order:**

**Westinghouse Electric Corporation  
Electrical Components Division  
250 Westinghouse Drive  
London, KY 40741**

**(C) Copyright 1990,1991,1992 by Westinghouse Electric Corporation  
All Rights Reserved**

**ATSRD-WD V1.2 10-9-92**

# Westinghouse Automatic Transfer Switch Wiring Diagrams

## Directions for Use

The drawing package can be used as a point to point wiring diagram for maintenance and diagnostic purposes for Solid State Logic SPB Transfer Switches. All voltages.

This document contains the following wiring information:

### **Page 1**

Basic Solid State Intelligence Panel Wiring exclusive of added option functions

### **Page 2**

Power Switching Panel basic wiring exclusive of added option functions.

### **Pages 3 - 18**

Wiring for optional functions

### **Page 19**

Legend Sheet describing symbols used throughout this document

Note: Unnumbered sheets may be added to this document on specific occasions to illustrate custom options additions per order instructions.

All transfer switch units will be standardly wired as indicated by Pages 1, and 2. The Intelligence Panel and Power Panel are interconnected via keyed plug/socket connectors (P1-S1/P2-S2). Your specific unit may be equipped with certain optional functions as noted which require additional wiring as shown on pages 3 - 18.

Wiring for optionally added functions will typically interface with the basic unit wiring (Pages 1 -2) which should be used as the base reference.

Note: **BOLD** lines on option wiring indicate components and wiring added to the basic wiring diagram to accomplish that specific option function.

# Westinghouse Automatic Transfer Switch

## Standard Features

### **Test Pushbutton**

Simulates a power failure in the logic. Will cause the Generator to start, and load to transfer to the Emergency Source.

### **Undervoltage Protection on NORMAL (All phases)**

Monitors the voltage on the NORMAL source for an undervoltage condition. Should the voltage drop below a preset Dropout, the generator is started and transfer to the EMERGENCY Source takes place.

### **Engine Start Contact**

Contact that provides a closure to Engine controller when the NORMAL source fails.

### **Logic Disconnect**

Plugs provided to disconnect the logic circuitry for maintenance purposes.

### **Auxiliary Contacts**

Auxiliary contacts integral to the switching devices rated at 120 vac, 10 amps. These may be applied for customer use, and may be applied to certain customer specified options.

### **Fully Rated Neutral**

A fully rated solid neutral is supplied on all two and three pole switches. All four pole switches are supplied with switched neutral contacts of identical construction and rating as the power poles.

# SPB ATS INTELLIGENCE PANEL

## DRAWOUT TYPE SPB TRANSFER SWITCH

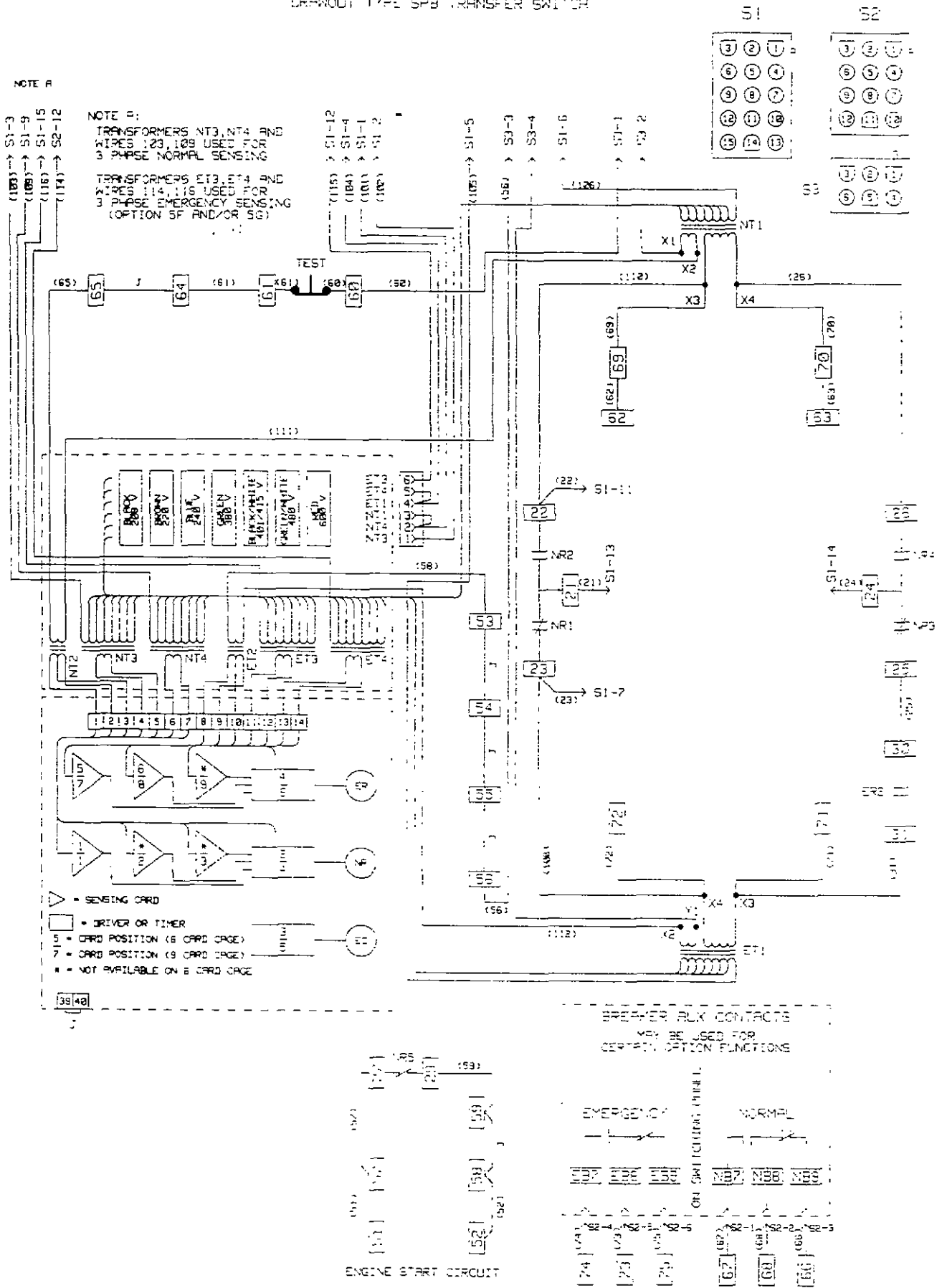

# SPB POWER SWITCHING PANEL WIRING DIAGRAM

PAGE 2

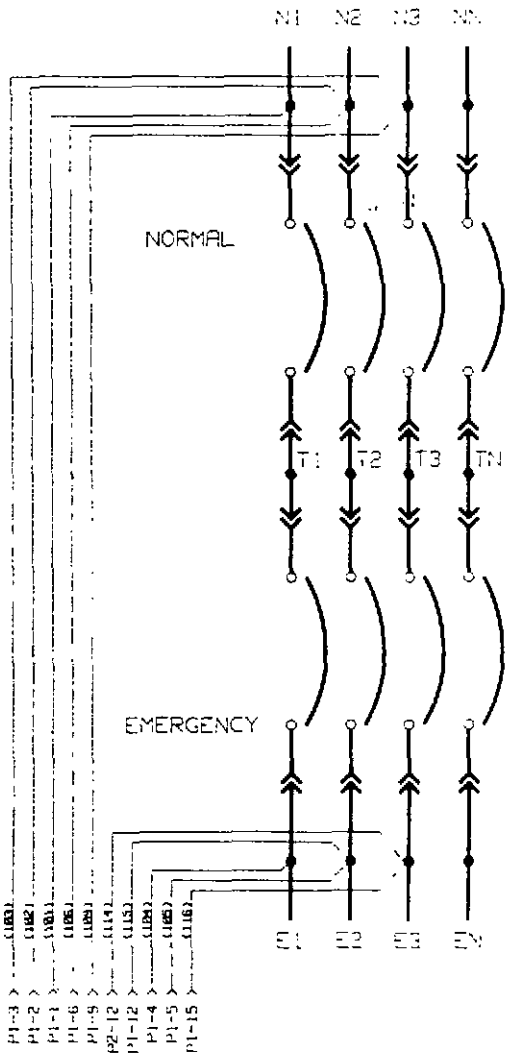

NORMAL CELL SWITCH

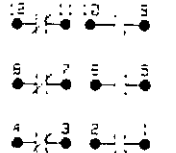

NOTE: CELL SWITCHES SHOWN WITH BREAKERS "DRAWN OUT"

EMERGENCY CELL SWITCH

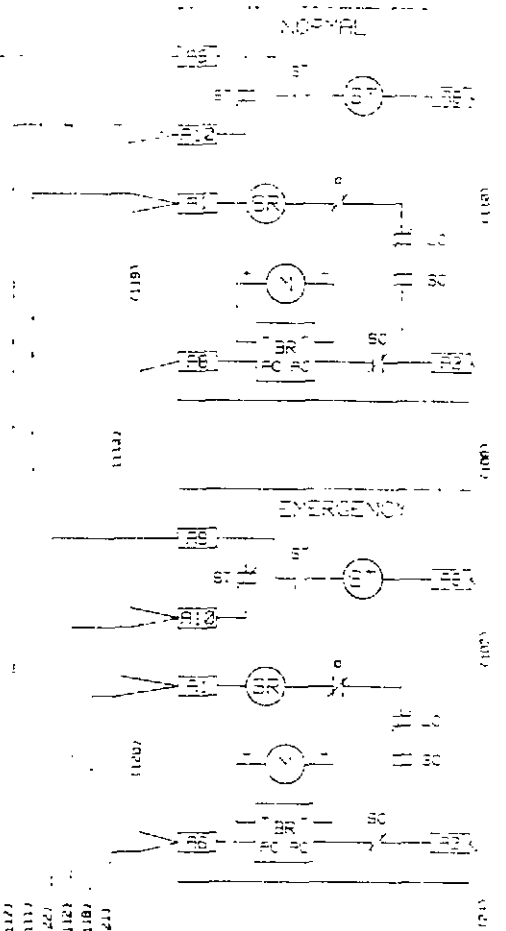
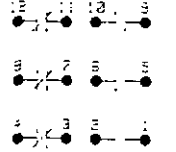

- 01 3 1 021
- 03 5 1 022
- 01 1 1 023
- 03 2 2 024
- 01 7 3 025
- 02 10 3 026
- 01 10 2 027
- 01 11 2 028
- 01 9 2 029
- 01 13 2 030

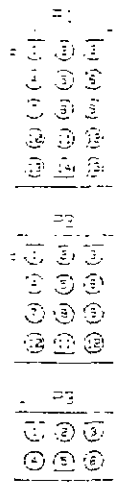
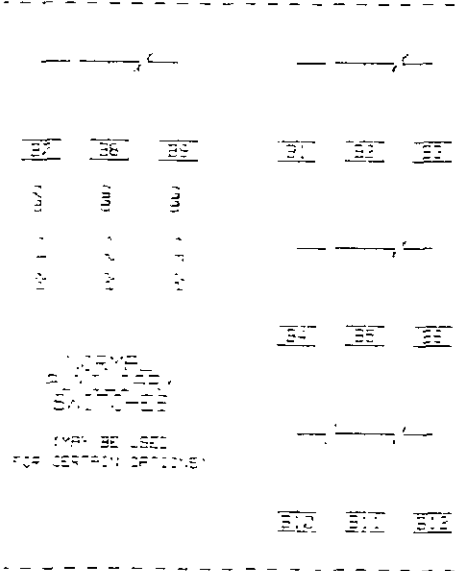
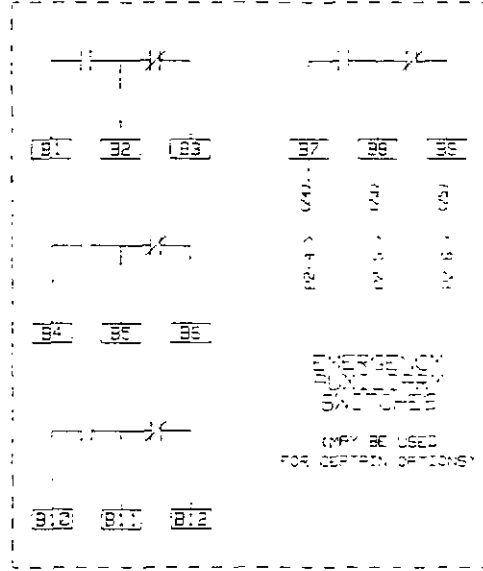

6 POSITION CARD CAGE

NORMAL		ENG	EMERGENCY		
1	2	3	4	5	6
UNDERVOLTAGE	STD	DRIVER (OPTION 3)	BLANK (OPTION 4)	DRIVER (OPTION 1)	BLANK (OPTION 5)

9 POSITION CARD CAGE

NORMAL			ENG	EMERGENCY		
1	2	3	4	5	6	7
UNDERVOLTAGE	STD	BLANK (OPTION 26)	BLANK (OPTION 26)	DRIVER (OPTION 3)	BLANK (OPTION 4)	DRIVER (OPTION 1)
						BLANK (OPTION 5)
						BLANK (OPTION 5)
						BLANK (OPTION 5)

OPTION 1 - TIME DELAY NORMAL TO EMERGENCY (TDNE)

6 POSITION CARD CAGE  
REPLACE DRIVER CARD IN POSITION 4 WITH TIMER CARD

9 POSITION CARD CAGE  
REPLACE DRIVER CARD IN POSITION 6 WITH TIMER CARD

OPTION 3 - TIME DELAY EMERGENCY TO NORMAL (TDEN)

6 POSITION CARD CAGE  
REPLACE DRIVER CARD IN POSITION 2 WITH TIMER CARD

9 POSITION CARD CAGE  
REPLACE DRIVER CARD IN POSITION 4 WITH TIMER CARD

OPTION 4 - TIME DELAY ENGINE COOLOFF (TDEC)

6 POSITION CARD CAGE  
REPLACE BLANK CARD IN POSITION 3 WITH TIMER CARD  
ADD EC RELAY TO MOTHERBOARD

9 POSITION CARD CAGE  
REPLACE BLANK CARD IN POSITION 5 WITH TIMER CARD  
ADD EC RELAY TO MOTHERBOARD

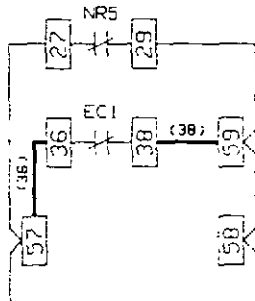

OPTION 4 ONLY

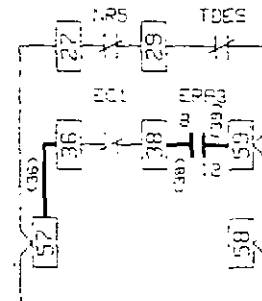

OPTION 4 WITH 2 \*\*  
\*\* REQUIRES OPTION 148

OPTION 5 - EMERGENCY SENSING (UV,OV,LF,OF)

6 POSITION CARD CAGE  
REPLACE BLANK CARD IN POSITION 3 OR 5 WITH APPROPRIATE SENSING CARD

9 POSITION CARD CAGE  
REPLACE BLANK CARD IN POSITION 7, 8 OR 9 WITH APPROPRIATE SENSING CARD

OPTION 26 - NORMAL SENSING (OV,LF,OF)

6 POSITION CARD CAGE  
NOT AVAILABLE

9 POSITION CARD CAGE  
REPLACE BLANK CARD IN POSITION 2 OR 3 WITH APPROPRIATE SENSING CARD

\* UNDERVOLTAGE SENSING ON NORMAL IS STANDARD

OPTION 2 - TIME DELAY ENGINE START (TDES)

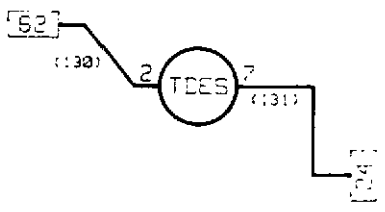

OPTION 6D - TEST SELECTOR (TSS)

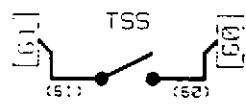

REPLACES STANDARD TEST PUSHBUTTON

OPTION 6H - FOUR POSITION SELECTOR SWITCH (FPSS)

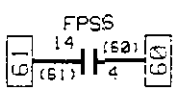

REPLACES STANDARD TEST SELECTOR SWITCH

FPSS	1.9	1.11	1.4	1.15	1.17
TEST	X	X	X	X	X
AUTO	X	X	X	X	X
OFF	X	X	X	X	X
ENG. RUN	X	X	X	X	X

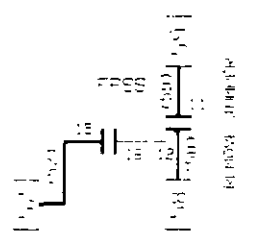
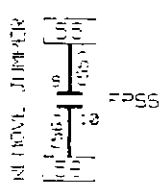
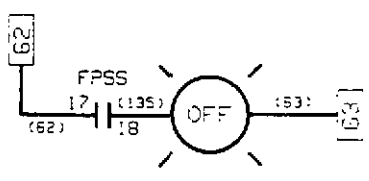

OPTION 8C - BYPASS TDM TIMER (BPTD)

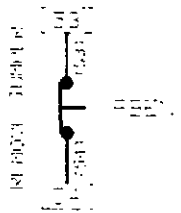

OPTION 8D - BYPASS TDM TIMER (BPTD)

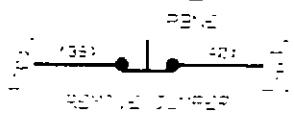

OPTION 9 - MAINTENANCE SELECTOR SWITCH

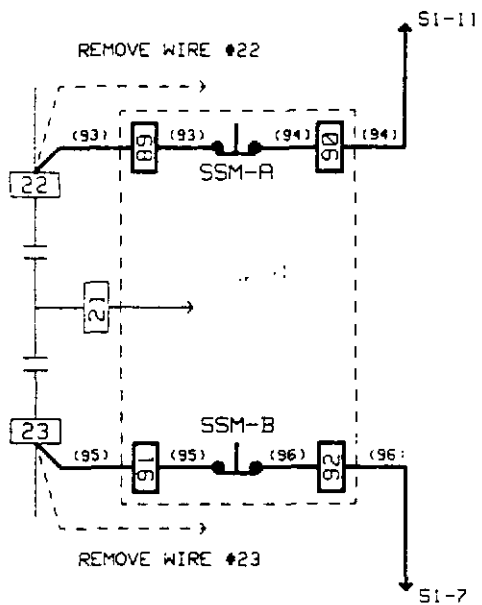

- OPTION 12C - NORMAL POSITION LIGHT (NL)  
INDICATES LOAD IS CONNECTED TO NORMAL

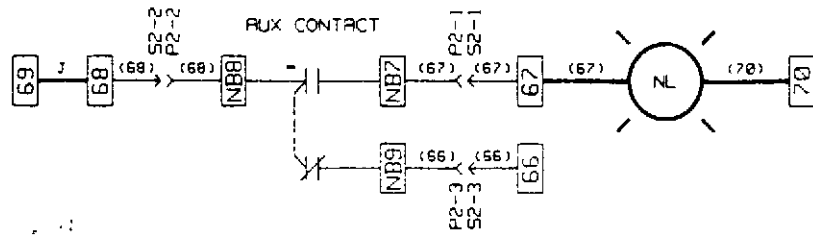

- OPTION 12D - EMERGENCY POSITION LIGHT (EL)  
INDICATES LOAD IS CONNECTED TO EMERGENCY

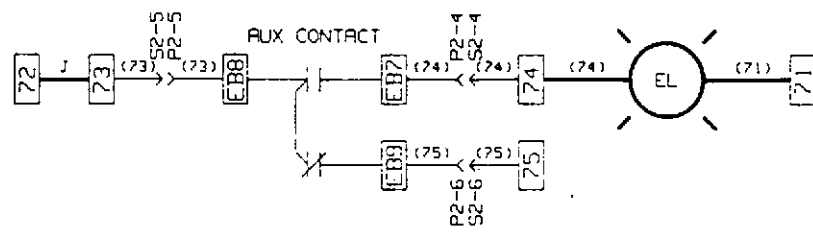

- OPTION 12G - NORMAL SOURCE LIGHT (SN)  
INDICATES NORMAL SOURCE AVAILABLE

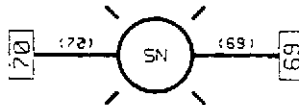

- OPTION 12H - EMERGENCY SOURCE LIGHT (SE)  
INDICATES EMERGENCY SOURCE AVAILABLE

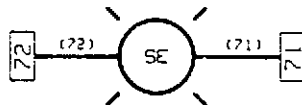



OPTION 14C - NORMAL AUXILIARY RELAY (NRA)  
 PROVIDES ADDITIONAL RELAY CONTACTS ON NORMAL

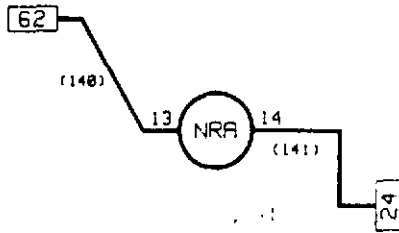

NOTE: CUSTOMER CONTACTS ARE ON RELAY SOCKET  
 SEE SOCKET DIAGRAM BELOW

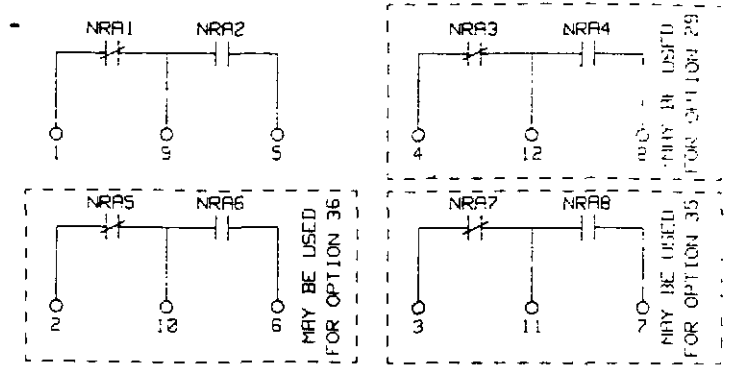

OPTION 14D - EMERGENCY AUXILIARY RELAY (ERA)  
 PROVIDES ADDITIONAL RELAY CONTACTS ON EMERGENCY



NOTE: CUSTOMER CONTACTS ARE ON RELAY SOCKET  
 SEE SOCKET DIAGRAM BELOW

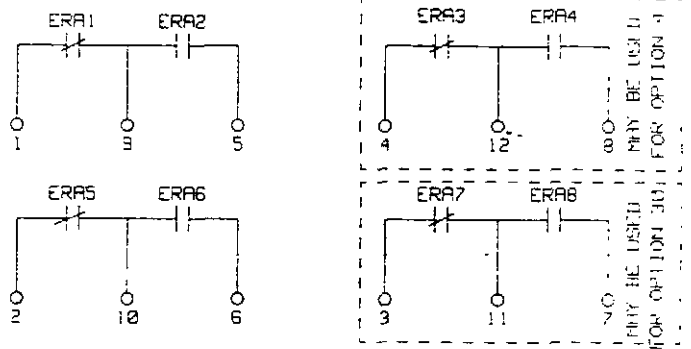

NRA - ERA SOCKET DIAGRAM

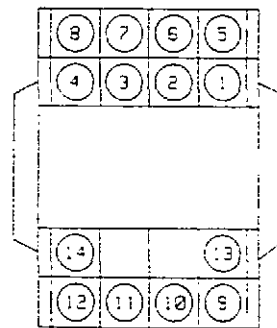

OPTION 18E - VOLTMETER

	HANDLE POSITION					
	NORMAL			EMERGENCY		
	1-3	2-3	1-2	1-2	2-3	1-3
1 -  2				X		X
3 -  4	X		X			
5 -  6					X	
7 -  8		X				
9 -  10						X
11 -  12	X					
13 -  14				X	X	
15 -  16		X	X			

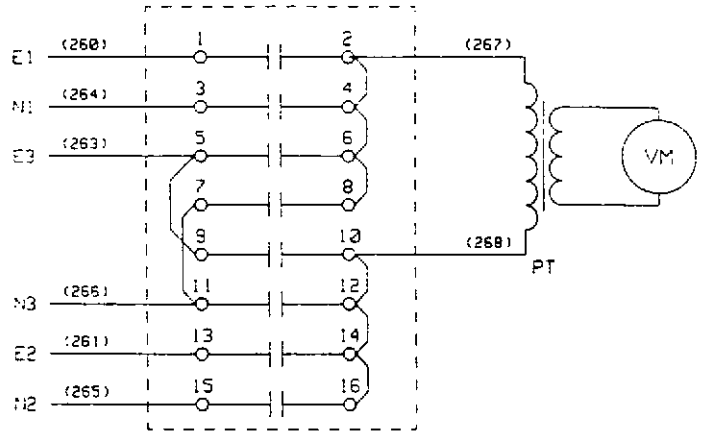

OPTION 18F - AMMETER

	HANDLE POSITION						
	OFF	-	1	-	2	-	3
1 -  2	X	X	X	X	X	X	X
3 -  4	X	X	X	X	X	X	X
5 -  6	X	X	X	X	X	X	X
7 -  8	X	X	X	X	X	X	X
9 -  10	X	X	X	X	X	X	X
11 -  12	X	X	X	X	X	X	X

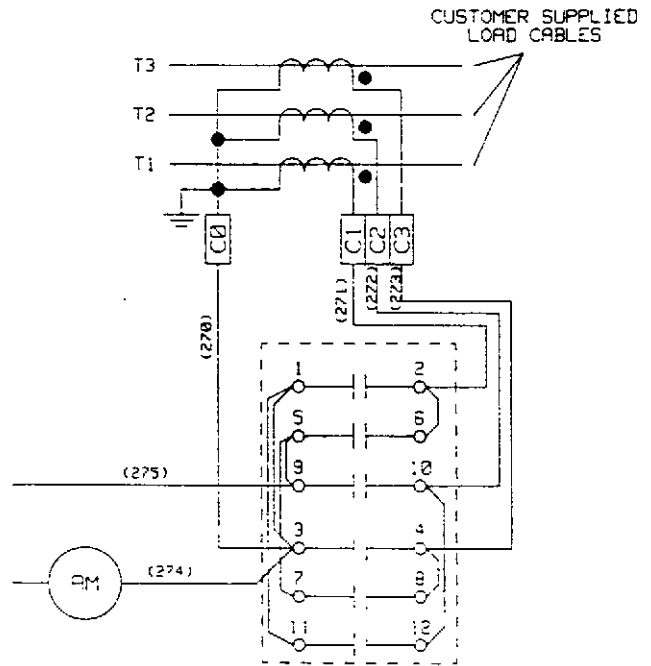

OPTION 18G - FREQUENCY METER

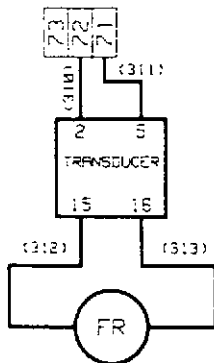

OPTION 18H - RUNNING TIME METER

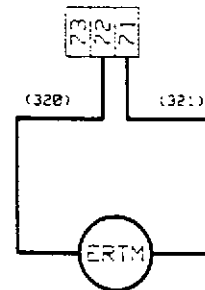

- OPTION 23C - PLANT EXERCISER  
RUN ENGINE AT SPECIFIED TIME  
(NO LOAD)

(151)	(152)	(153)	(154)	(155)
-------	-------	-------	-------	-------

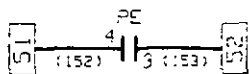
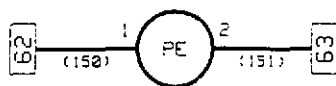

PE TERMINAL BLOCK

- OPTION 23D = 23D W/FAILSAFE
- OPTION 23G = 23G W/FAILSAFE

- OPTION 23D - PLANT EXERCISER  
RUN ENGINE AT SPECIFIED TIME  
(LOAD)

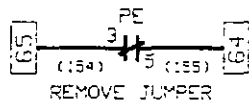
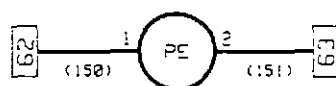

FAILSAFE CIRCUIT

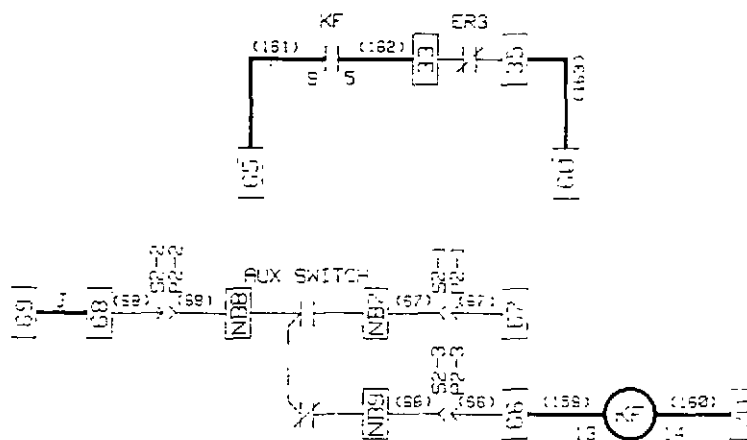

- OPTION 23G - PLANT EXERCISER  
RUN ENGINE AT SPECIFIED TIME  
(SWITCH SELECTABLE  
LOAD OR NO LOAD)

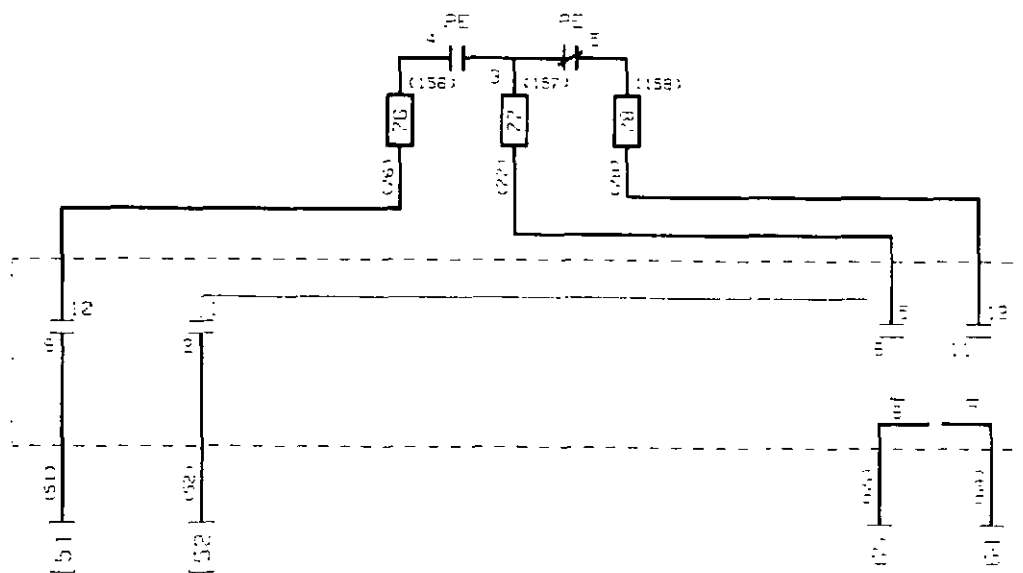
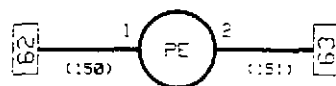

REMOVE JUMPER 84-55

	ENGINE PULL	BYPASS	LOAD LIFT
1	---	---	---
2	---	---	---
3	---	---	---
4	---	---	---
5	---	---	---
6	---	---	---
7	---	---	---
8	---	---	---
9	---	---	---
10	---	---	---

OPTION 28A - INTELLIGENCE CIRCUIT FUSES  
 FUSES NON-ESSENTIAL CIRCUITS ONLY

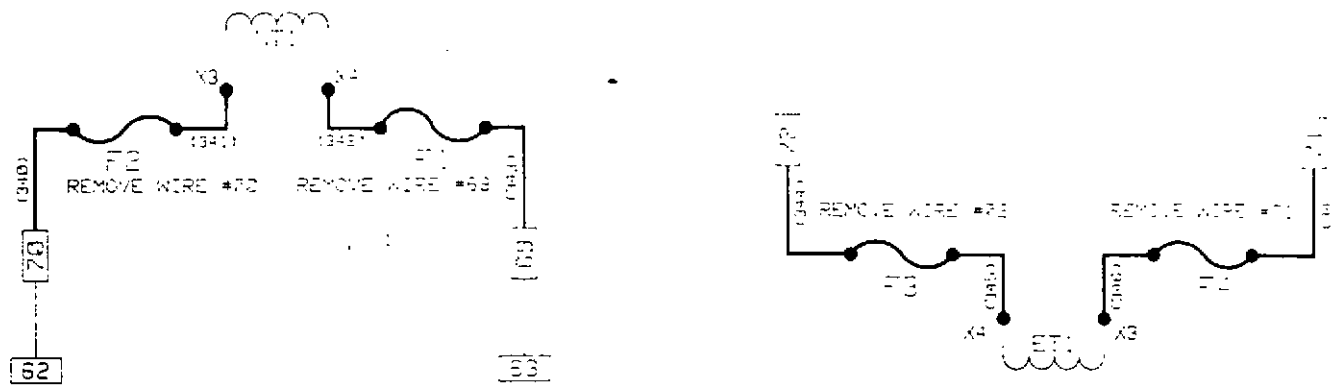

OPTION 30 - TIME DELAY CRANK LIMITER (TDC)  
 INTERRUPTS ENGINE START CIRCUIT IF VOLTAGE DOES NOT APPEAR WITHIN A PRESELECTED TIME

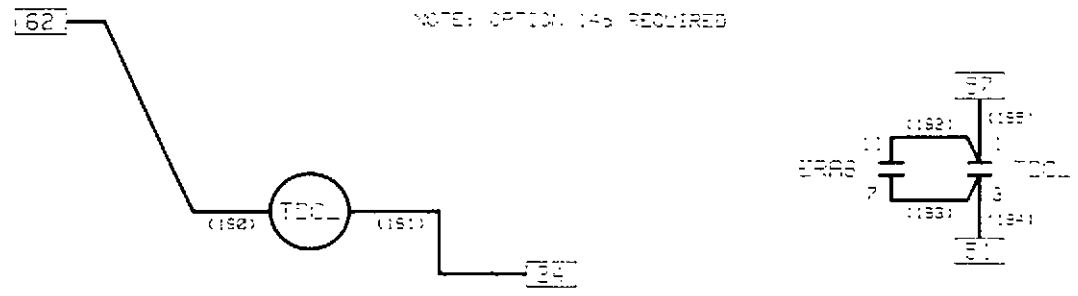

OPTION 31B - FLUID LEVEL FLARE  
 FLARE WHEN OIL LEVEL LOWS OR HIGH

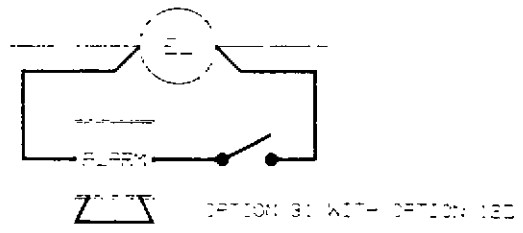
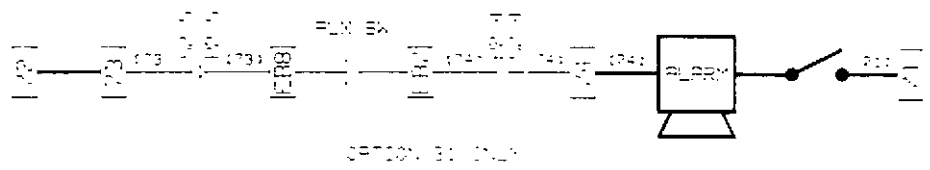

OPTION 29E - MANUAL RETURN TO NORMAL

REQUIRES OPTION 140  
OPTION 9 MAY NOT BE USED

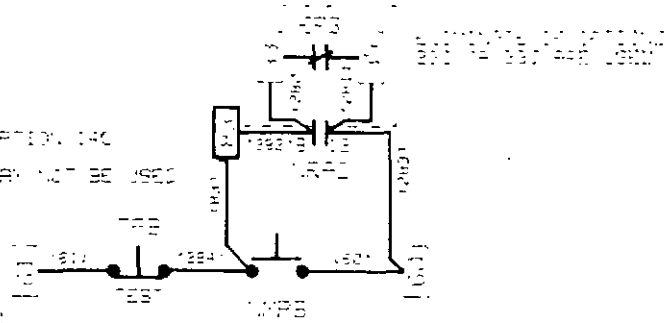

OPTION 29J - AUTOMATIC/MANUAL RETURN TO NORMAL

REQUIRES OPTION 140

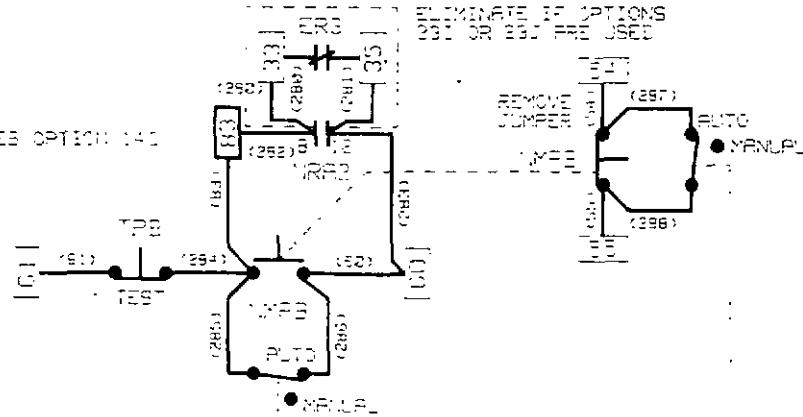

OPTION 29G - AUTOMATIC/MANUAL OPERATION

REQUIRES OPTION 140

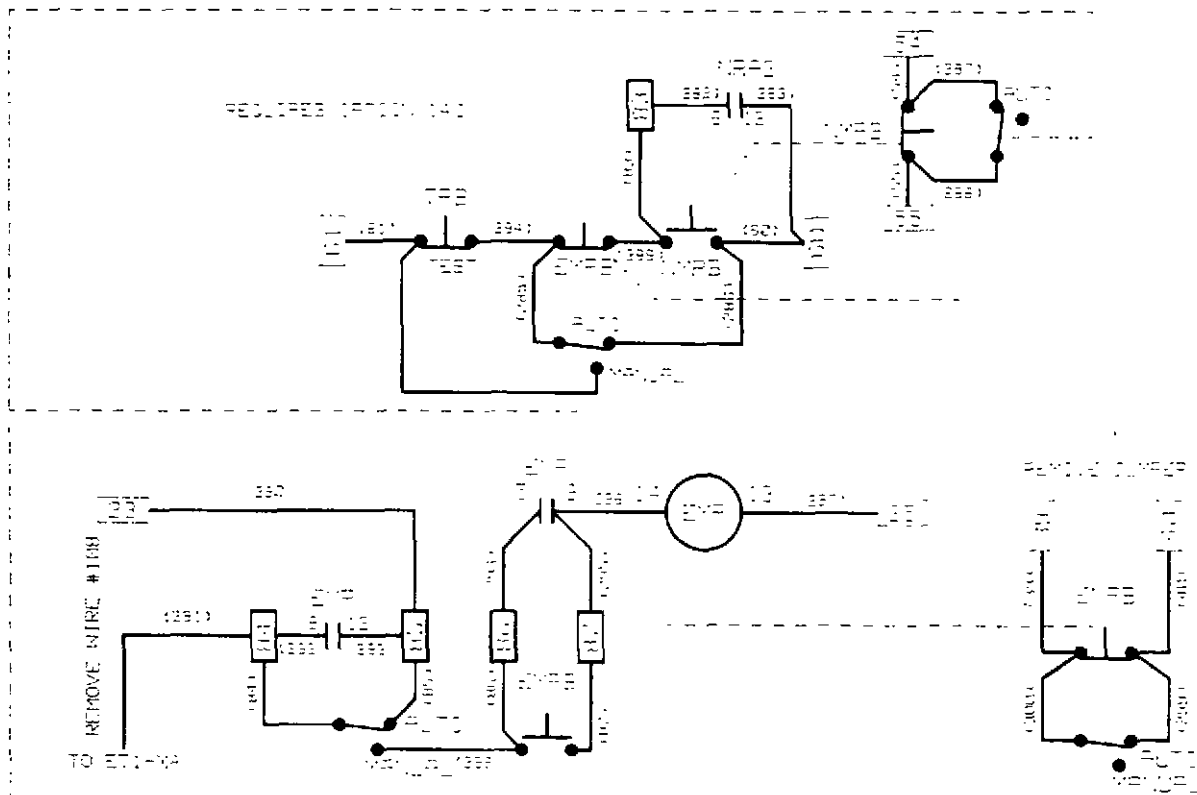

OPTION 16 - SPB DIGITRIP

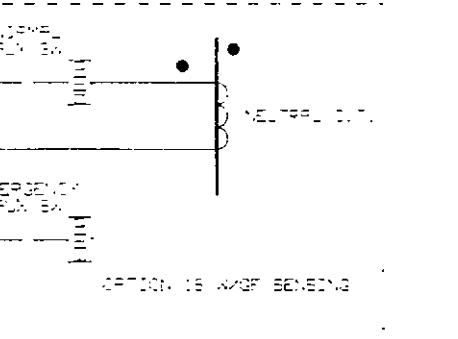
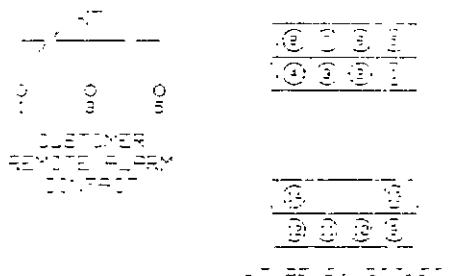
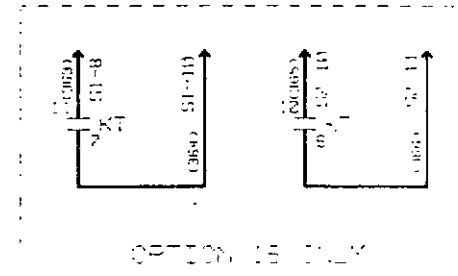
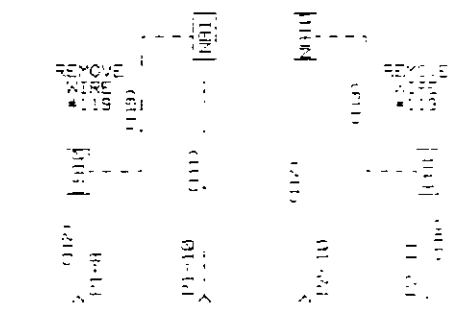
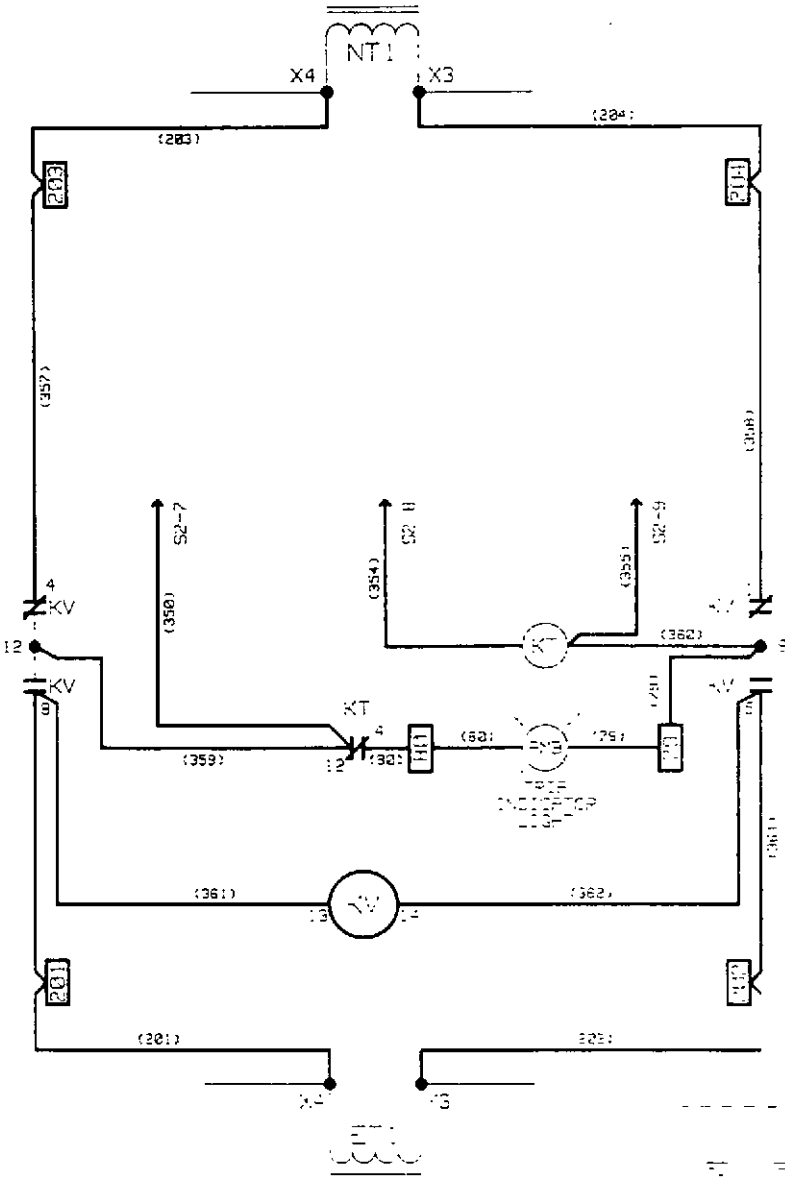
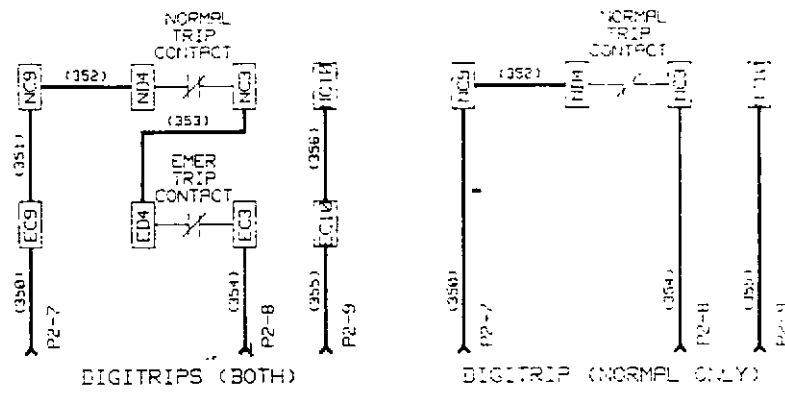

OPTION 16 W/SPB DIGITRIP

OPTION 32 - TIME DELAY NEUTRAL

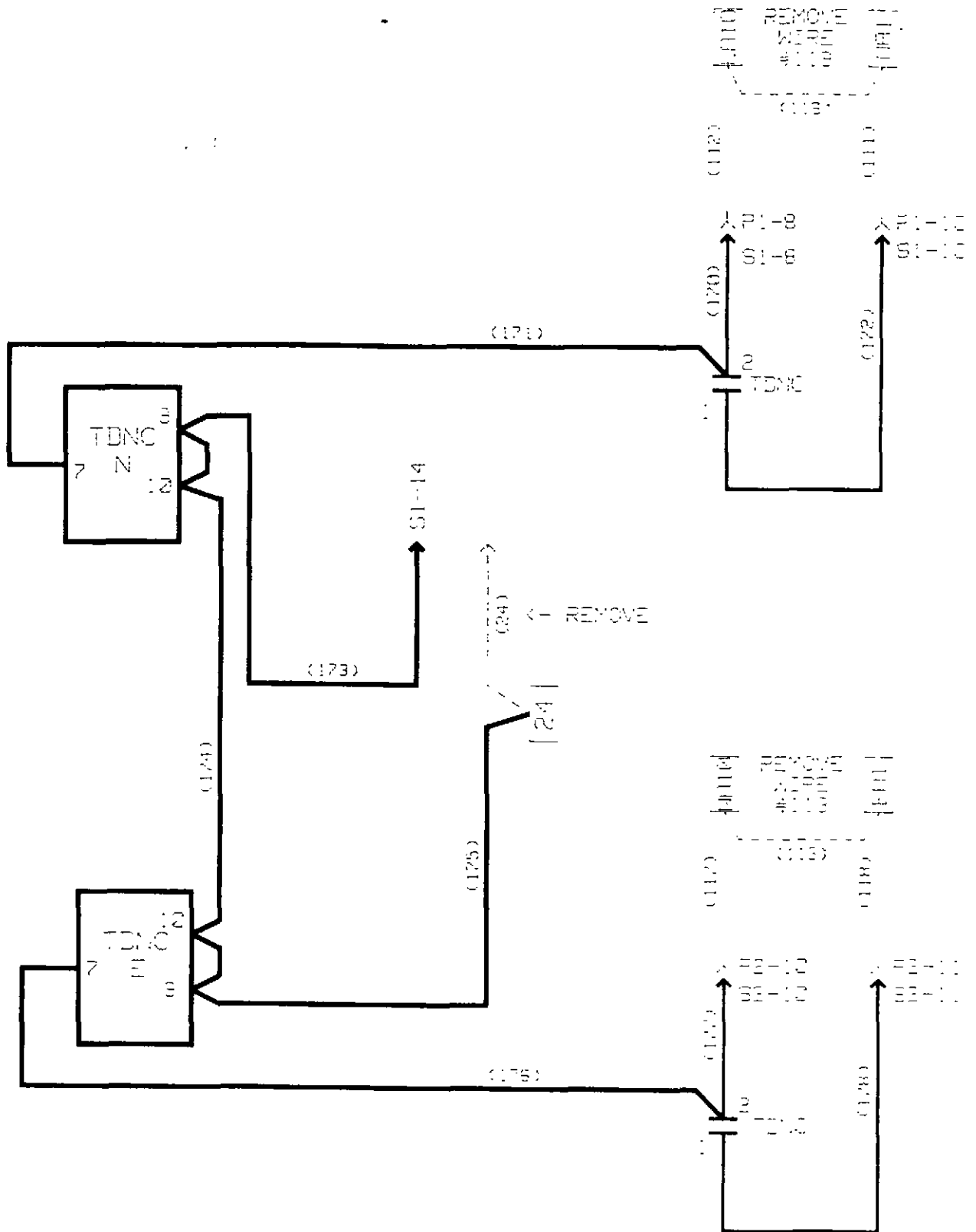



# OPTION 35 - PRETRANSFER SIGNAL DEVICE

(OPTION 14 REQUIRED)

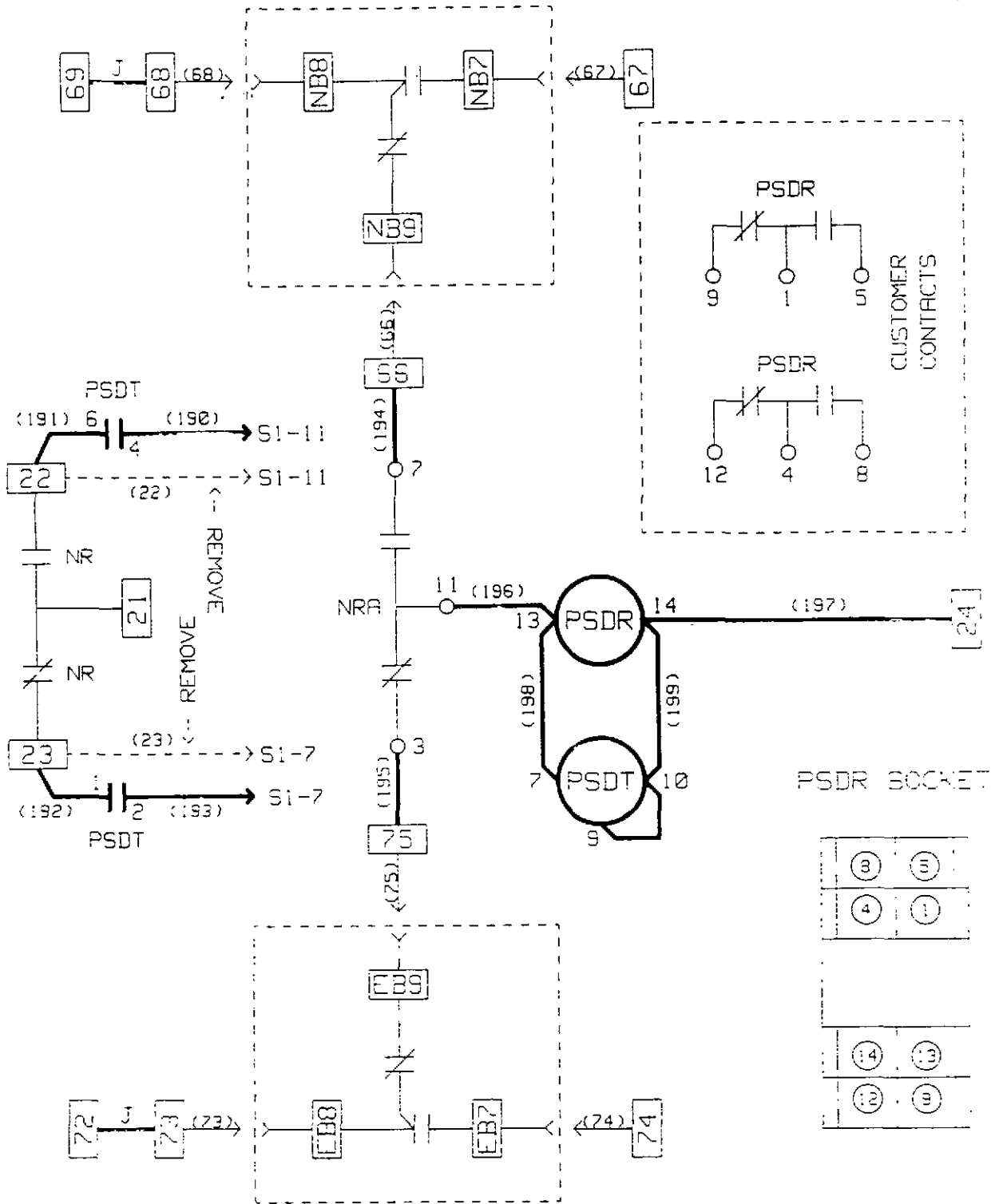

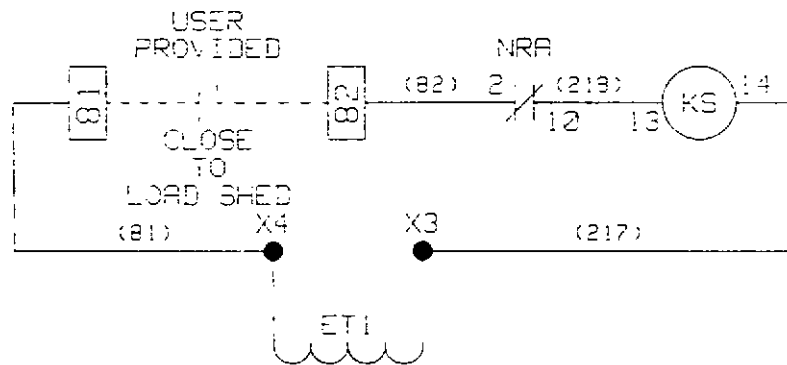
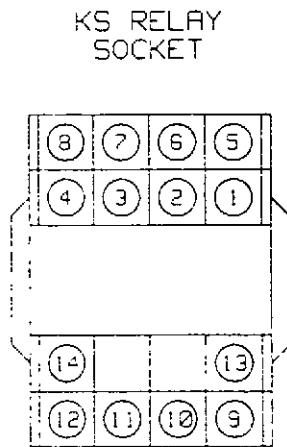
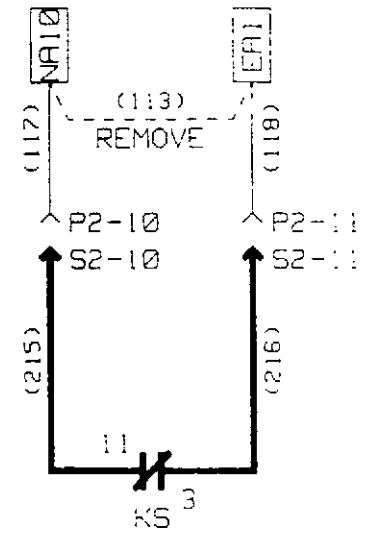
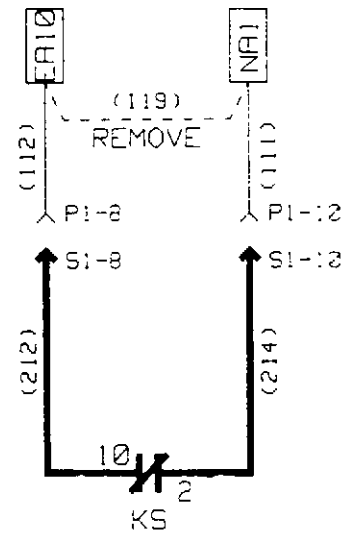
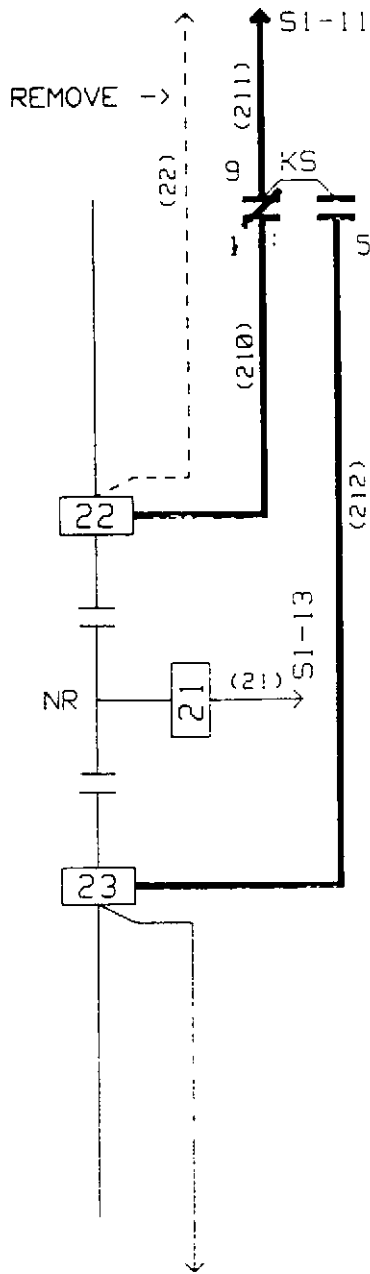

OPTION 37 - BEPVIDE ENTRANCE  
 (MUST USE OPTION 15)

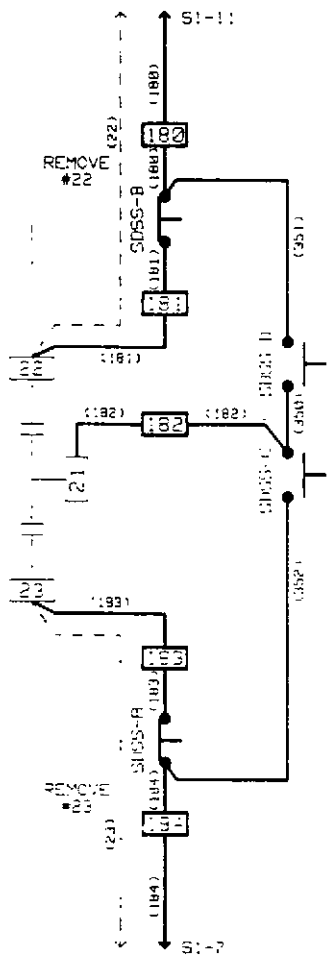
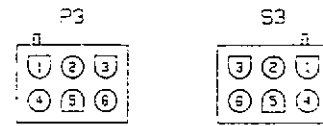
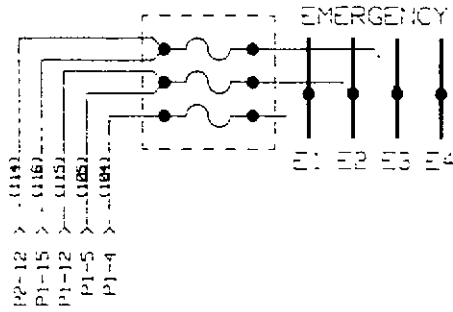
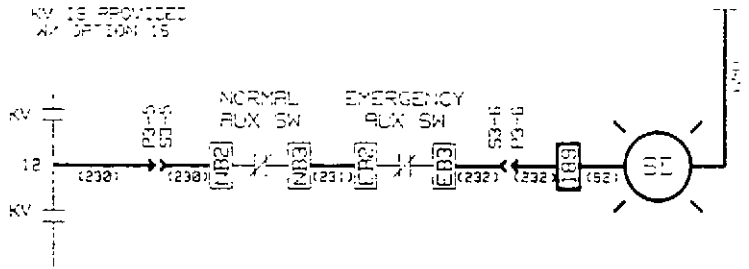
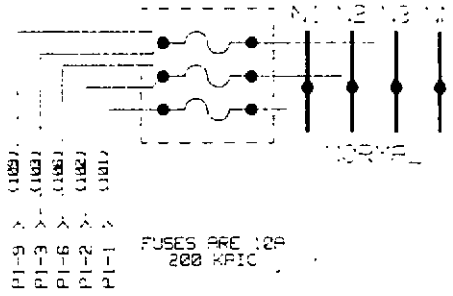

SERVICE	DISCONNECT	EMERGENCY
DISCONNECT	EMERGENCY	DISCONNECT
EMERGENCY	DISCONNECT	EMERGENCY

KEY LOCKED  
KEY REMOVABLE  
IN "DISCONNECTED" POSITION

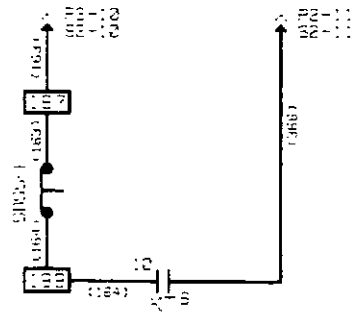
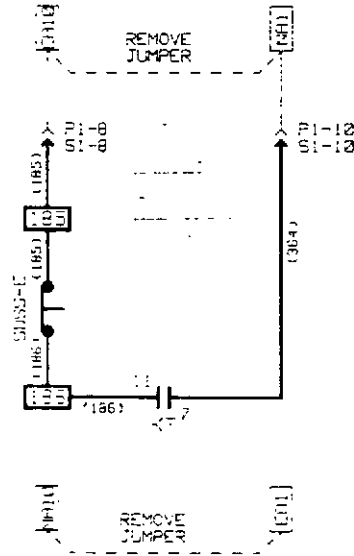

# COMBINATION WIRING

## OPTIONS 16, 32, 35, 36, AND 37

THIS DRAWING SHOWS INTER WIRING OF THESE OPTIONS WHEN COMBINED

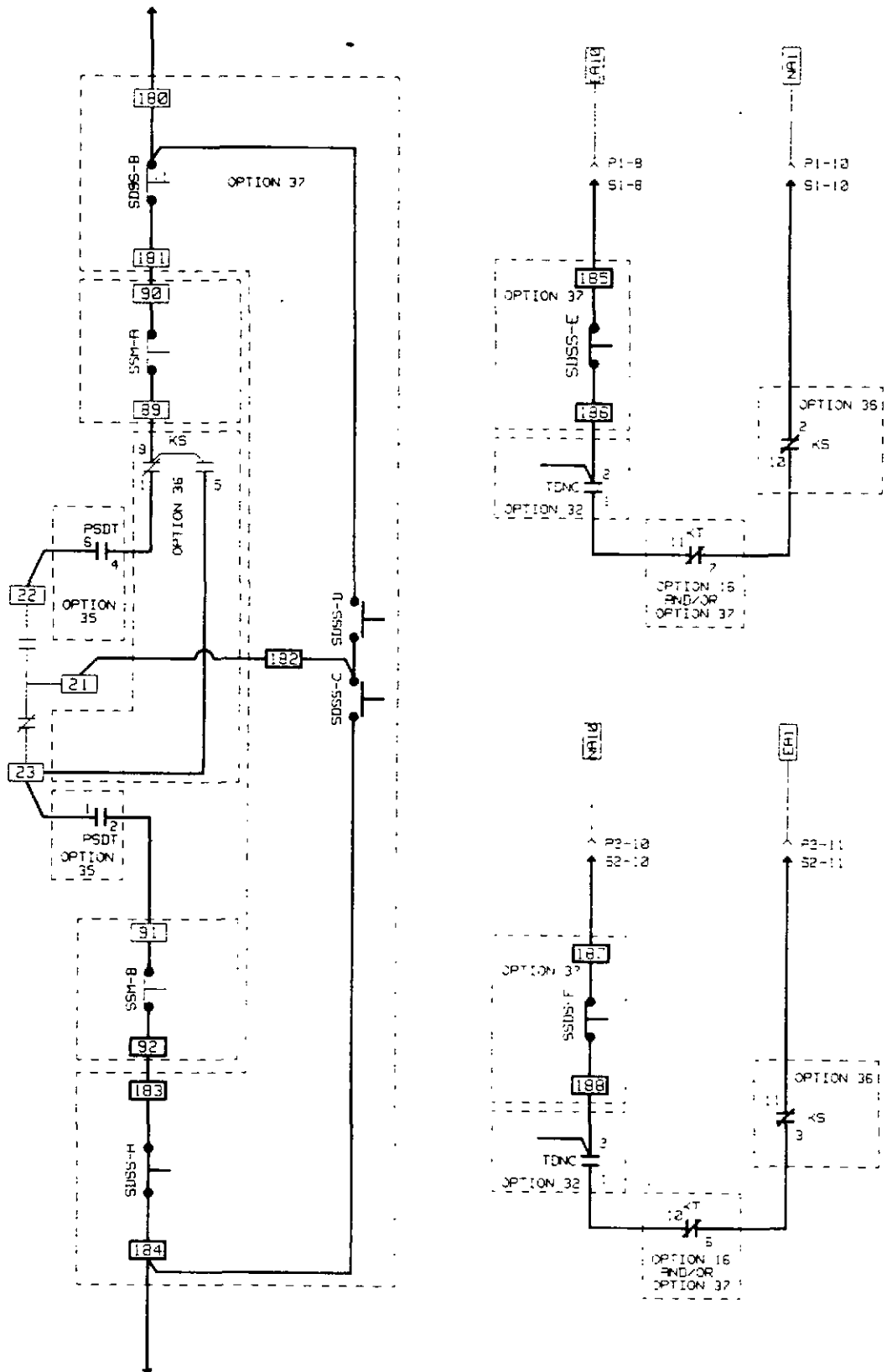

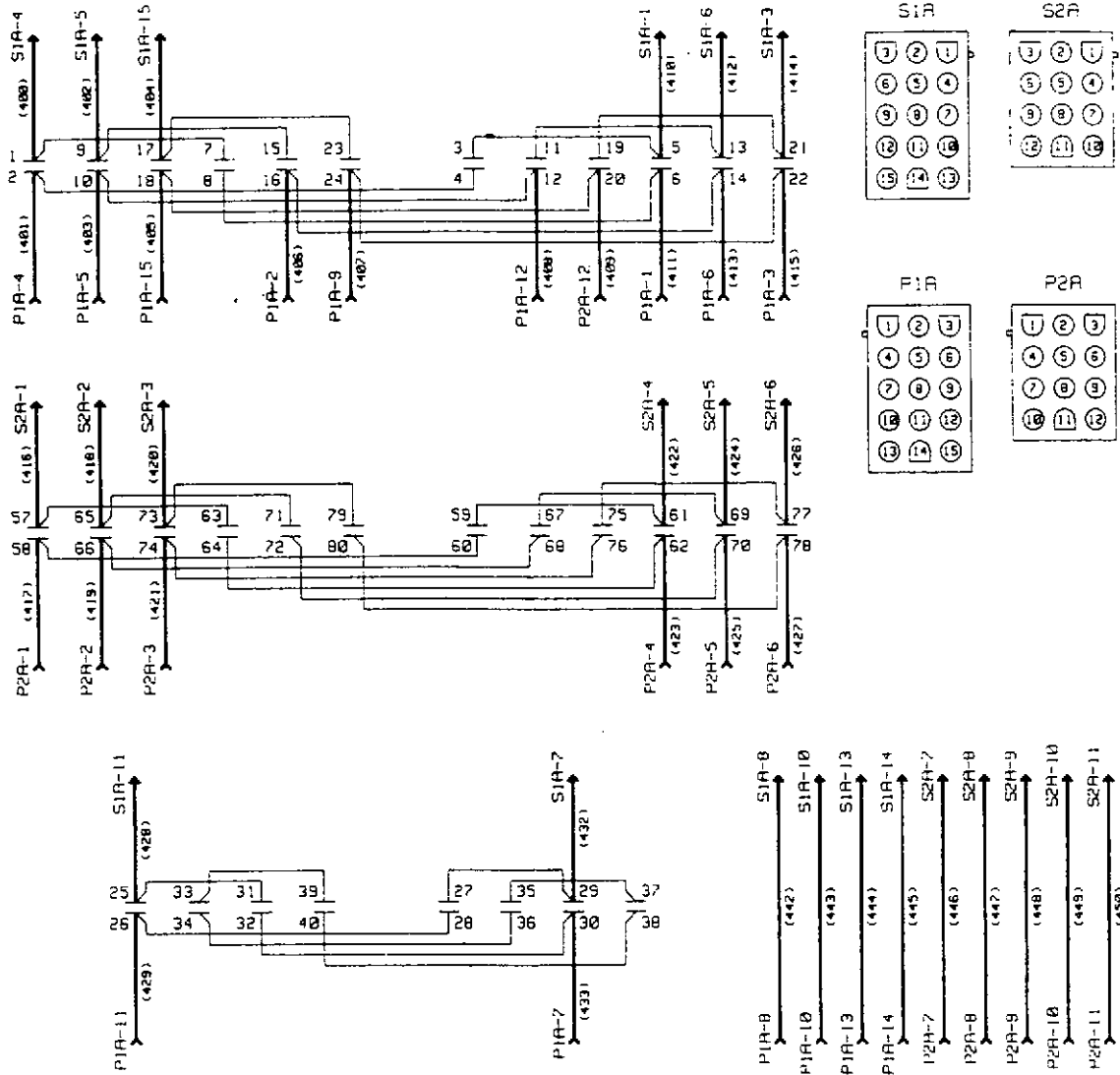

1-2	3-4	5-6	7-8	9-10	11-12	13-14	15-16	17-18	19-20	21-22	23-24	25-26	27-28	29-30	31-32	33-34	35-36	37-38	39-40	41-42	43-44	45-46	47-48	49-50	51-52	53-54	55-56	57-58	59-60	61-62	63-64	65-66	67-68	69-70	71-72	73-74	75-76	77-78	79-80
NORMAL																																							
EMERGENCY																																							

(M) PART NO. 598B730-102

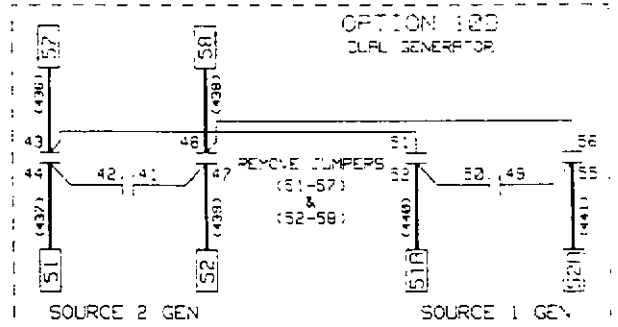
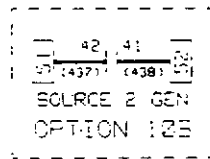
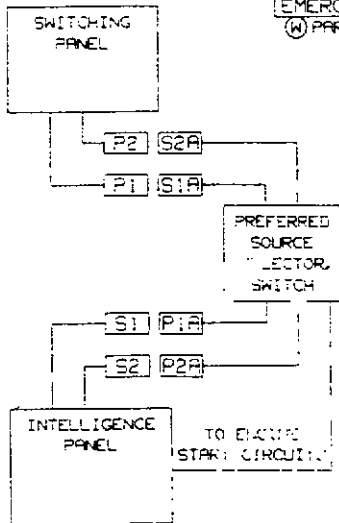

Westinghouse SPB Automatic Transfer Switch  
Legend for Wiring Diagram Symbols

Symbol Description

---

AM	Ammeter
Ex	Power Terminal, Emergency Source (x = Terminal Number)
EASx	Emergency Lockout (x = contact number)
EC	Engine Cooloff Relay Coil
ECx	Engine Cooloff Relay Contact (x = contact number)
EL	Emergency Position Indicator Light
EMPB	Emergency Pushbutton for Manual Operation
EMR	Emergency Relay (Manual Operation)
ER	Emergency Relay Coil
ERx	Emergency Relay Contact (x = contact number)
ERA	Emergency Auxiliary Relay Coil
ERAx	Emergency Auxiliary Relay Contact (x = Contact Number)
ERTM	Generator Run Time Meter
ESx	Emergency Auxiliary Switch (x = contact number)
ET1	Emergency Transformer (Line Voltage to 120vac - 2 windings)
ET2	Emergency Transformer (120 to 24vac CT)
ET3	Emergency Transformer (Line Voltage to 12vac)
ET4	Emergency Transformer (Line Voltage to 12vac)
FPCS	Four Position Selector Switch (Option 6H)
FR	Frequency Meter
Fx	Fuse (x = Fuse Number)
KF	Failsafe Relay
KS	Load Shed Relay
KT	Trip Relay (Used w/Option 16)
KV	Voting Relay
MSS	Maintenance Selector Switch
NASx	Normal Lockout (x = contact number)
Nx	Power Terminal, Normal (x = Terminal number)
NL	Normal Position Indicator Light
NMPB	Normal Pushbutton for Manual Operation
NR	Normal Relay Coil
NRx	Normal Relay Contact (x = contact number)
NRA	Normal Auxiliary Relay Coil
NRAx	Normal Auxiliary Relay Contact (x = contact number)
NSx	Normal Auxiliary Switch (x = contact number)
NT1	Normal Transformer (Line Voltage to 120vac - 2 windings)
NT2	Normal Transformer (120 to 24vac CT)
NT3	Normal Transformer (Line Voltage to 12vac)
NT4	Normal Transformer (Line Voltage to 12vac)
Px-y	Plug (x = number, y = Terminal number)
PBEN	Bypass TDEN Pushbutton
PBNE	Bypass TDNE Pushbutton
PBRE	Pushbutton Reset Emergency Trip
PBRN	Reset Normal Breaker Trip Pushbutton
PE	Plant Exerciser
PSDR	Pre-Transfer Signal Device Relay
PSDT	Pre-Transfer Signal Device Timer
PSS	Preferred Source Selector Switch
Sx-y	Socket (x = number, y = Terminal number)
SDL	Service Disconnect Light
SDSS	Service Disconnect Selector Switch
SD	Services Disconnected Light
SE	Emergency Source Available Indicator Light
SN	Normal Source Available Indicator Light
Tx	Power Terminal, Load (x = Terminal Number)
TDCL	Time Delay Crank Time Limiter
TDEC	Time Delay Engine Cool Down
TDEN	Time Delay Emergency to Normal
TDES	Time Delay Engine Start
TDNC	Time Delay Neutral
TDNE	Time Delay Normal to Emergency
TE	Emergency Trip Indicator Light
TM	Transfer Motor and Brake
TN	Normal Trip Indicator Light
TPB	Test Pushbutton
TSS	Test Selector Switch
VM	Voltmeter

**BYPASS ISOLATION SWITCH  
WITH  
AUTOMATIC TRANSFER SWITCH  
WIRING DIAGRAMS**

Catalog Number **ATSBI** Only  
Solid State Transfer Switch

Shop Order:

Westinghouse Electric Corporation  
Electrical Components Division  
250 Westinghouse Drive  
London, KY 40741

(C) Copyright 1990, 1991 by Westinghouse Electric Corporation  
All Rights Reserved

WESTINGHOUSE BYPASS/ISOLATION TRANSFER SWITCH  
WIRING DIAGRAMS

DIRECTIONS FOR USE

This drawing package can be used as a point to point wiring diagram for maintenance and diagnostic purposes for Solid State Logic Bypass/Isolation Transfer Switches, 100 - 1000 Amperes.

This document contains the following wiring information:

- Page 1 Standard Solid State Intelligence Panel wiring exclusive of added option functions.
- Page 2 Automatic Transfer Switch Power Switching Panel basic wiring, 100 - 1000 amperes exclusive of added option functions.
- Page 3 Basic Power Busing scheme for the Bypass/Isolation switch with Automatic Transfer Switch.
- Page 4 Auxiliary Power Panel wiring. This is the power supply for the Bypass Status Annunciator Panel, and Source/Load condition lights.
- Page 5 Automatic Transfer Switch Power wiring. This shows the interconnections between the ATS Switching Panel, the Intelligence Panel, and the Power Connections.
- Page 6 Harnesses used to supply power to the Bypass/Isolation Annunciator Panel, from the Auxiliary Power Panel, using appropriate contacts.
- Page 7 Wiring of typical attachments, and the Annunciator panel wiring.
- Pages 8 - 18  
Option wiring
- Page 19 Legend Sheet describing symbols used throughout this document.

Note: Unnumbered sheets may be added to this document on specific orders to illustrate custom option additions per customer instructions.

All Bypass/Isolation Switches will be standardly wired as indicated on sheets 1 thru 7. Your specific switch may be equipped with certain optional functions as noted which require additional wiring as shown on pages 8 - 18.

Note: BOLD LINES on the option drawings indicate components and wiring added to the basic wiring diagram to accomplish that specific option function.

# WESTINGHOUSE BYPASS/ISOLATION TRANSFER SWITCH

## STANDARD FEATURES

The following features are included as STANDARD on all units:

**TEST SELECTOR SWITCH** - Simulates a power failure in the logic. Will cause Generator to start, and load to transfer to the Emergency Source.

**UNDERVOLTAGE PROTECTION ON NORMAL (All phases)**  
Monitors the NORMAL source. Should the voltage drop below a preset dropout, the generator is started and transfer to the EMERGENCY Source takes place.

**ENGINE START CONTACT** - Contact that provides a closure to Engine controller when the NORMAL Source fails.

**GENERATOR SELECTOR SWITCH** -  
A three position switch (AUTO - OFF - RUN) is provided, to allow normal operation with the Automatic Transfer Switch, or to provide manual control when using the Bypass Switch.

**LOGIC DISCONNECT** - Plugs are provided to disconnect the logic circuitry for maintenance.

**STATUS INDICATORS** - A BYPASS STATUS ANNUNCIATOR PANEL is provided with the following indicators:

NORMAL BYPASS ENERGIZED  
NORMAL BYPASS TRIP  
EMERGENCY BYPASS ENERGIZED  
EMERGENCY BYPASS TRIP  
ISOLATED  
ISOLATOR TRIP

Standard indicators on the ATS STATUS PANEL are:

NORMAL POSITION ENERGIZED  
EMERGENCY POSITION ENERGIZED  
NORMAL SOURCE AVAILABLE  
EMERGENCY SOURCE AVAILABLE  
LOAD ENERGIZED

**AUXILIARY CONTACTS** - Auxiliary contacts integral to the Automatic Transfer Switch switching devices rated at 120VAC 10 amps for customer use. These may be applied to customer specific options.





# EMERGENCY SOURCE AND NORMAL SOURCE

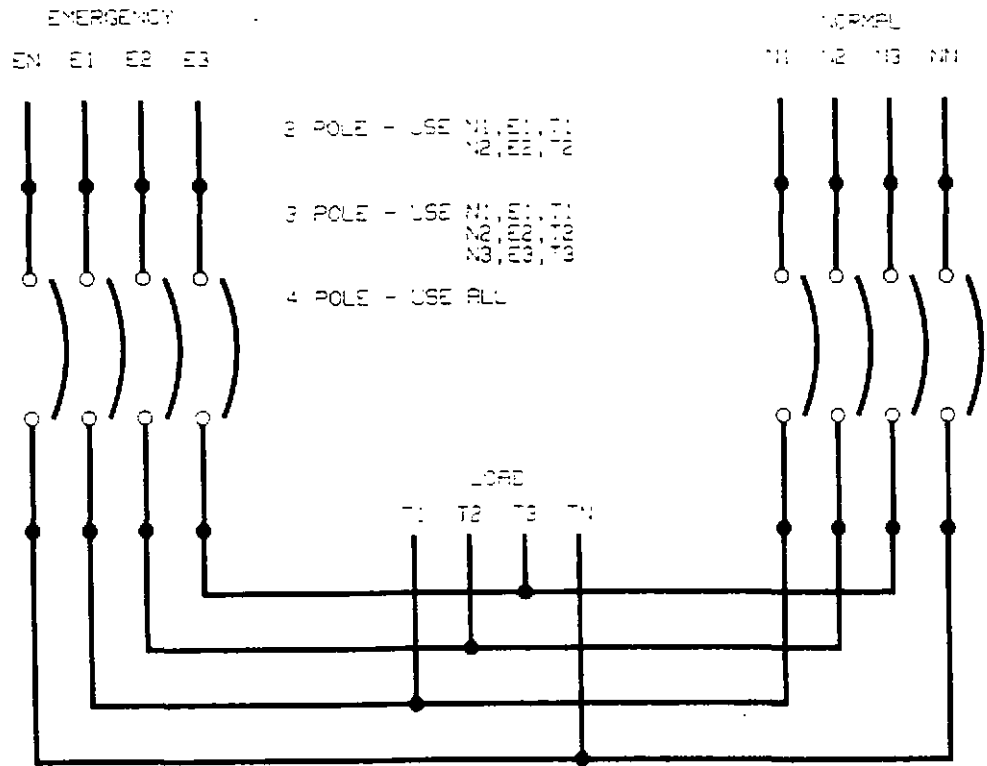

2 POLE - USE N1, N2, T1  
N2, N3, T2

3 POLE - USE N1, N2, T1  
N2, N3, T2, T3

4 POLE - USE ALL

EMERGENCY SOURCE  
FLX. CONTACTS

NORMAL SOURCE  
FLX. CONTACTS

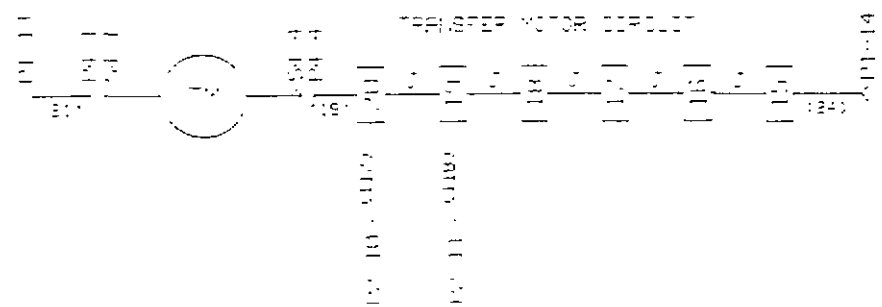
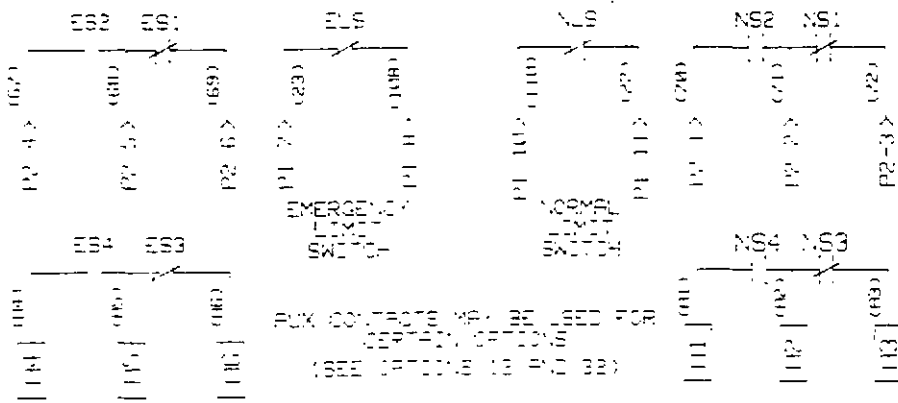

# BYPASS/ISOLATION SWITCH POWER WIRING

NOTE: POWER CONNECTIONS AS SHOWN ARE FOR DIAGRAM PURPOSES

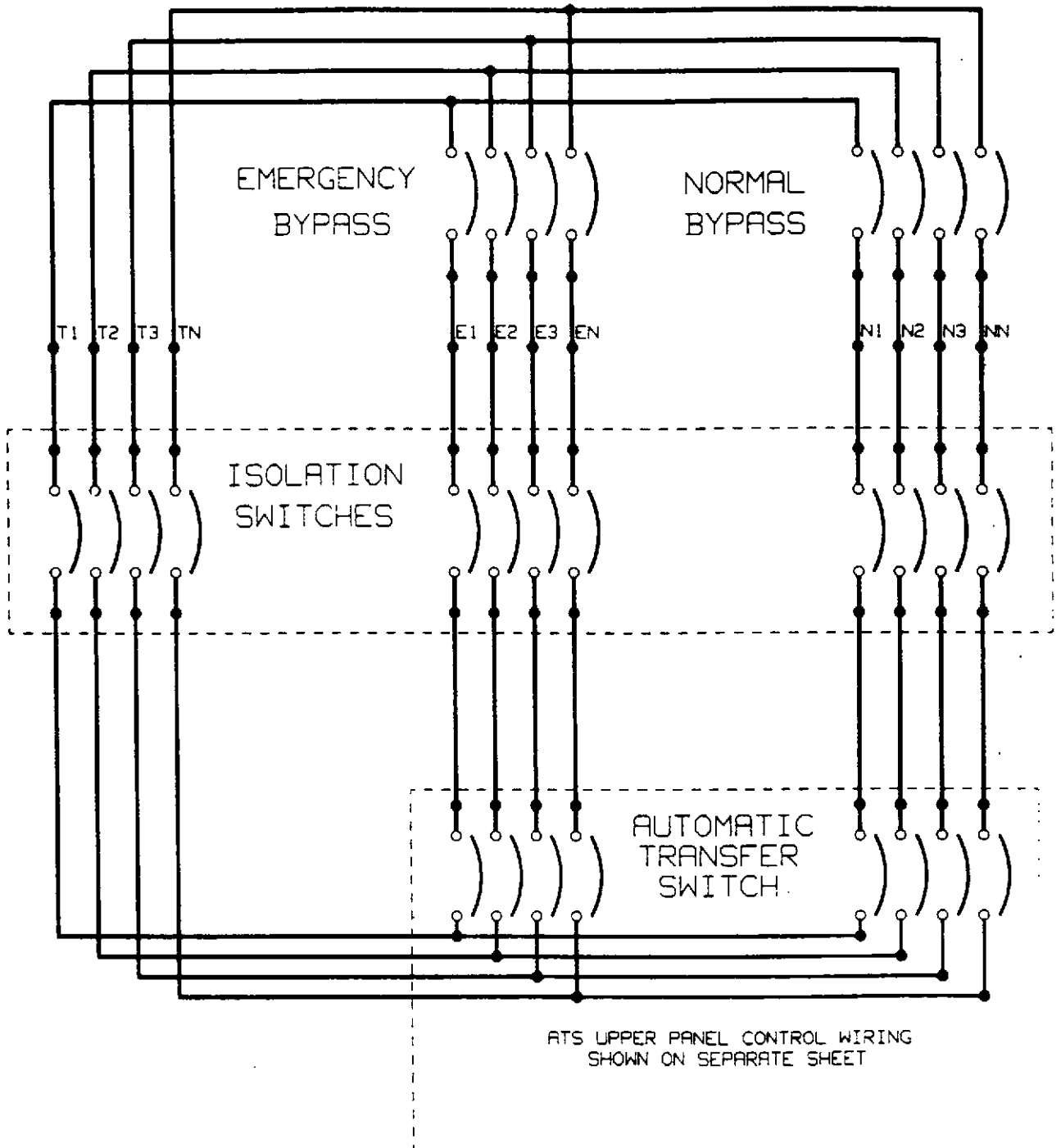

BYPASS/ISOLATION TRANSFER SWITCH  
 AUXILIARY POWER PANEL

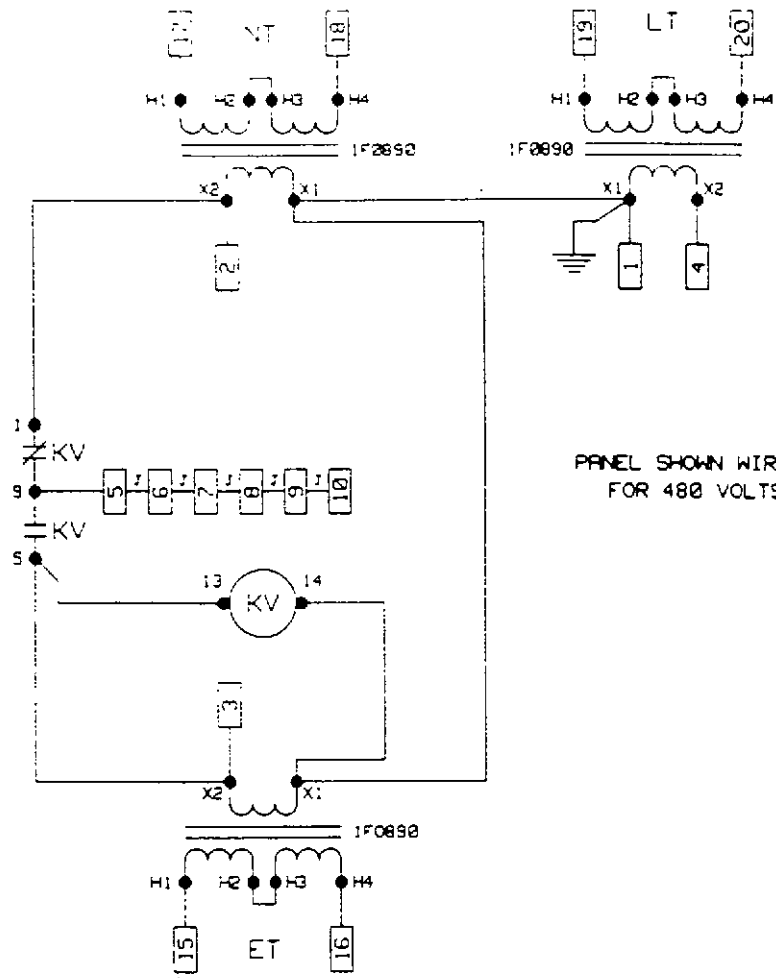

PANEL SHOWN WIRED  
 FOR 480 VOLTS

TYPICAL TRANSFORMER WIRING FOR OTHER VOLTAGES

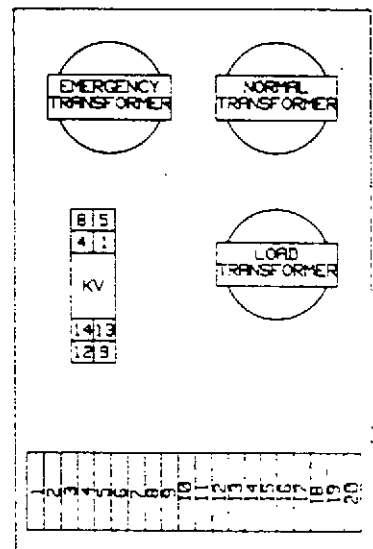
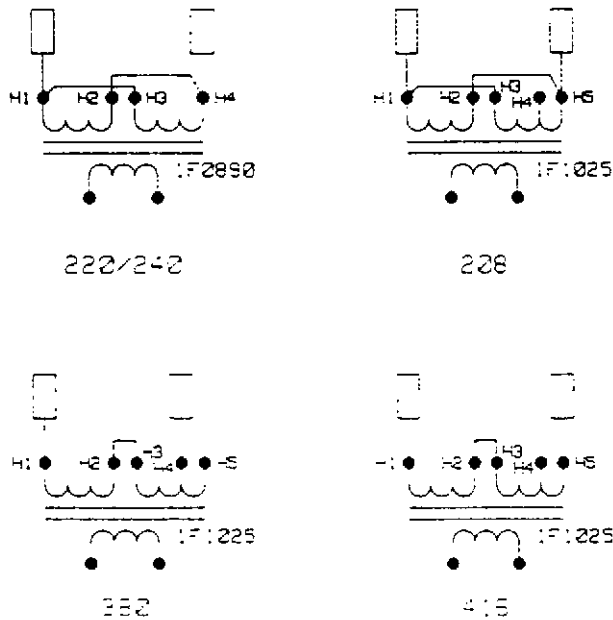

# BYPASS ISOLATION SWITCH ATS POWER HARNESS

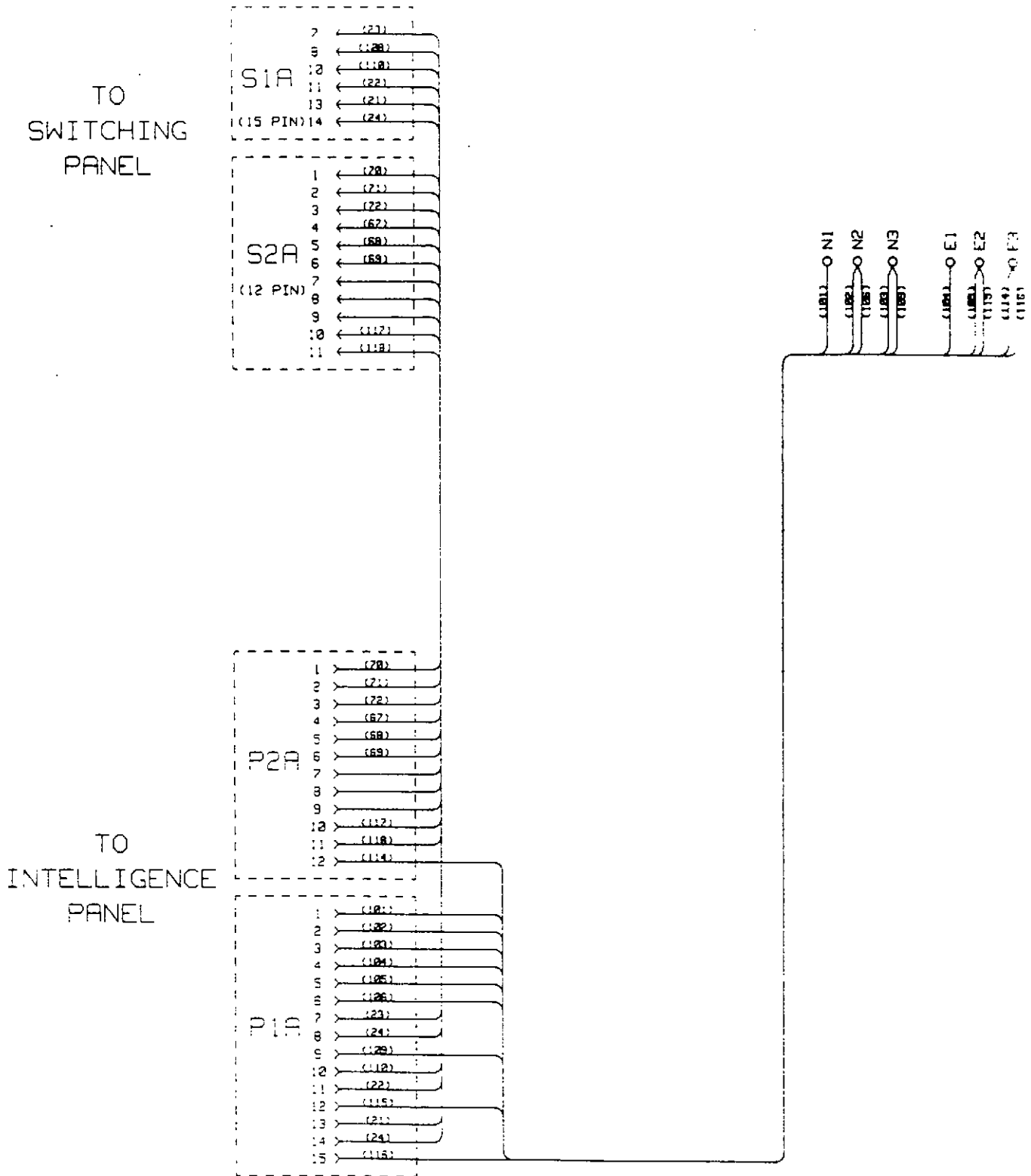

# BYPASS/ISOLATION SWITCH STATUS INDICATOR HARNESSSES

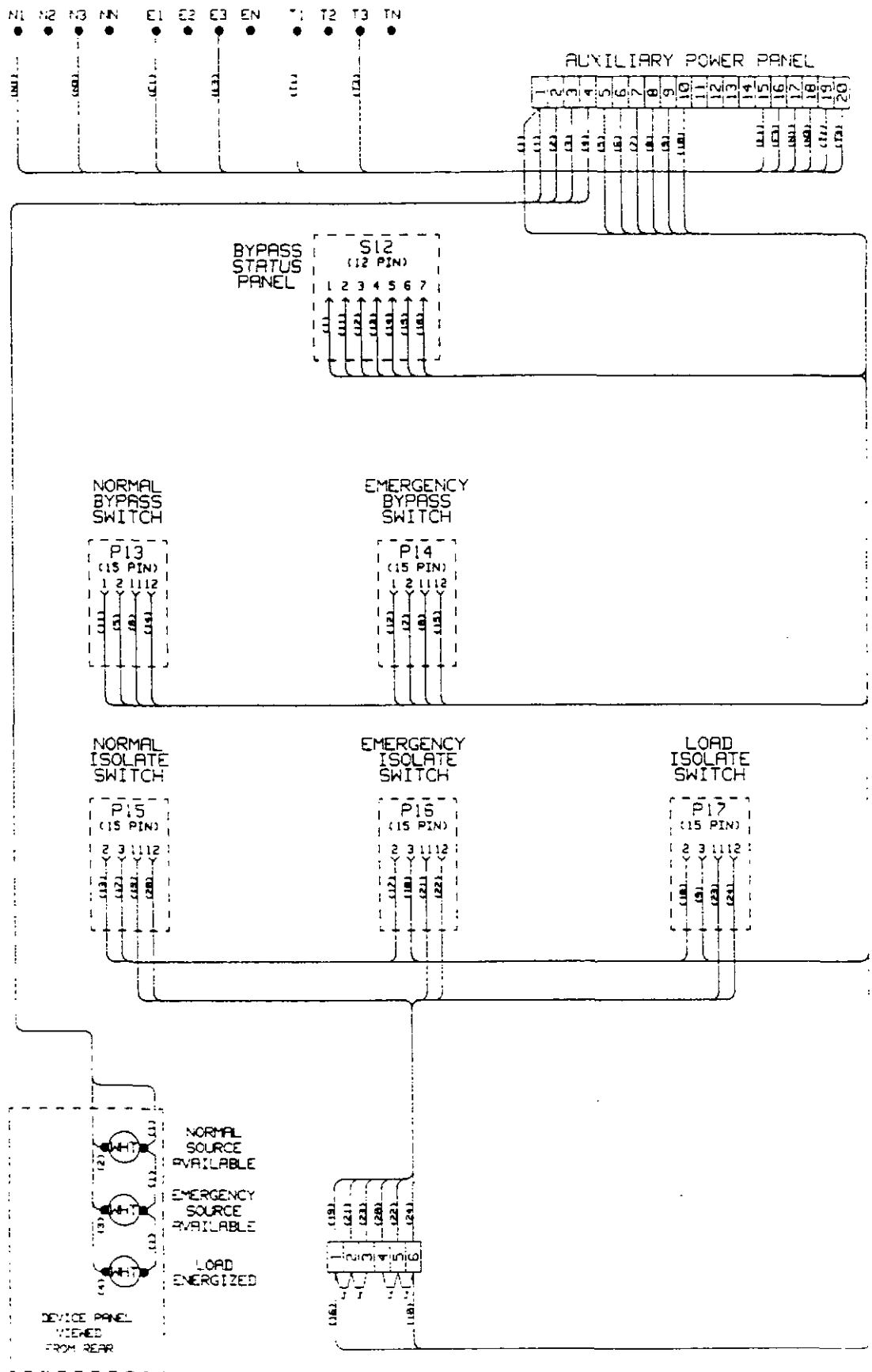

# BYPASS/ISOLATION SWITCH MISCELLANEOUS DEVICES

TYPICAL ATTACHMENT WIRING

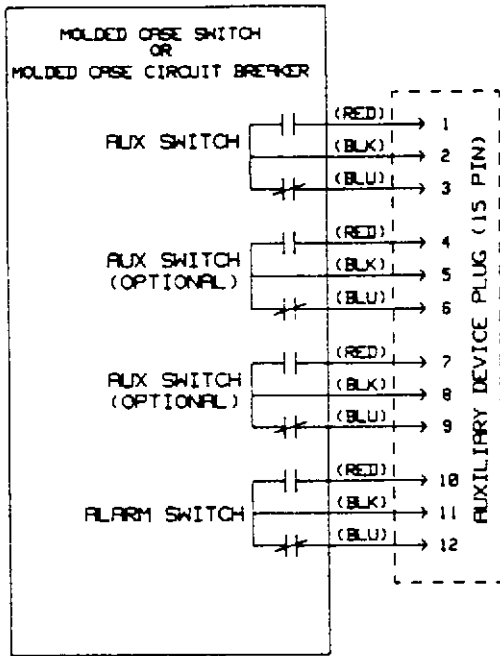

BYPASS STATUS  
ANNUNCIATOR PANEL

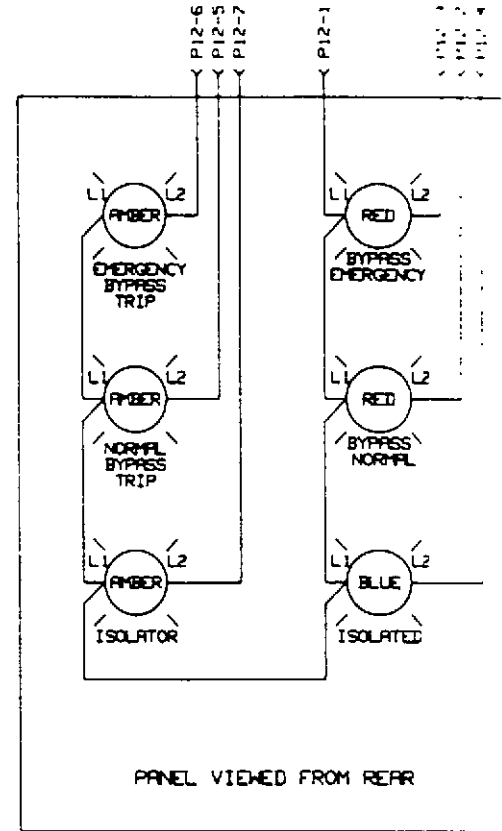

6 POSITION CARD CAGE

NORMAL			EMERGENCY		
1	2	3	4	5	6
UNDERVOLTAGE	STD	DRIVER (OPTION 3)	BLANK (OPTION 4)	DRIVER (OPTION 1)	BLANK (OPTION 5)

9 POSITION CARD CAGE

NORMAL				ENG		EMERGENCY		
1	2	3	4	5	6	7	8	9
UNDERVOLTAGE	STD	BLANK (OPTION 26)	BLANK (OPTION 26)	DRIVER (OPTION 3)	BLANK (OPTION 4)	DRIVER (OPTION 1)	BLANK (OPTION 5)	BLANK (OPTION 5)

OPTION 1 - TIME DELAY NORMAL TO EMERGENCY (TDNE)

6 POSITION CARD CAGE

REPLACE DRIVER CARD IN POSITION 4 WITH TIMER CARD

9 POSITION CARD CAGE

REPLACE DRIVER CARD IN POSITION 6 WITH TIMER CARD

OPTION 3 - TIME DELAY EMERGENCY TO NORMAL (TDEN)

6 POSITION CARD CAGE

REPLACE DRIVER CARD IN POSITION 2 WITH TIMER CARD

9 POSITION CARD CAGE

REPLACE DRIVER CARD IN POSITION 4 WITH TIMER CARD

OPTION 4 - TIME DELAY ENGINE COOLOFF (TDEC)

6 POSITION CARD CAGE

REPLACE BLANK CARD IN POSITION 3 WITH TIMER CARD  
ADD EC RELAY TO MOTHERBOARD

9 POSITION CARD CAGE

REPLACE BLANK CARD IN POSITION 5 WITH TIMER CARD  
ADD EC RELAY TO MOTHERBOARD

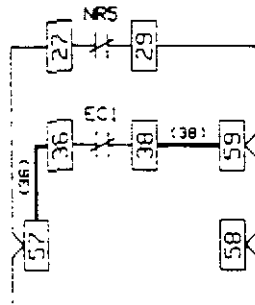

OPTION 4 ONLY

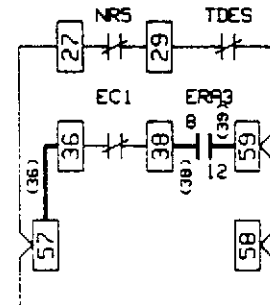

OPTION 4 WITH 2 \*\*  
\*\* REQUIRES OPTION 14D

OPTION 5 - EMERGENCY SENSING (OV,OV,UF,OF)

6 POSITION CARD CAGE

REPLACE BLANK CARD IN POSITION 5 OR 6 WITH APPROPRIATE SENSING CARD

9 POSITION CARD CAGE

REPLACE BLANK CARD IN POSITION 7,8 OR 9 WITH APPROPRIATE SENSING CARD

OPTION 25 - NORMAL SENSING (OV,UF,OF)

6 POSITION CARD CAGE

NOT AVAILABLE

9 POSITION CARD CAGE

REPLACE BLANK CARD IN POSITION 2 OR 3 WITH APPROPRIATE SENSING CARD

\* UNDERVOLTAGE SENSING ON NORMAL IS STANDARD

OPTION 2 - TIME DELAY ENGINE START (TDES)

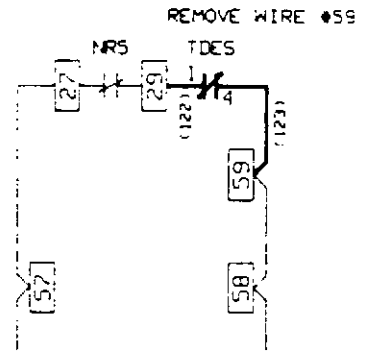
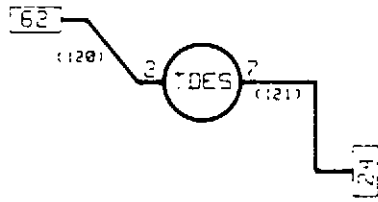

OPTION 6D - TEST SELECTOR SWITCH (TSS)

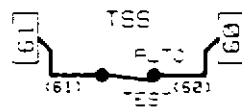

REPLACES STANDARD TEST PUSHBUTTON

OPTION 6H - FOUR POSITION SELECTOR SWITCH (FPSS)

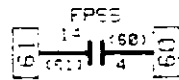

REPLACES STANDARD TEST PUSHBUTTON

FPSS	JJ9 14	JJ1 12	JJ4 14	JJ5 16	JJ7 14
TEST	X	X	X	X	X
AUTO	X	X	X	X	X
OFF	X	X	X	X	X
ENG. RUN	X	X	X	X	X

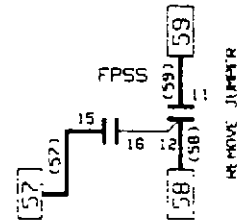
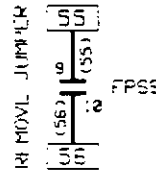
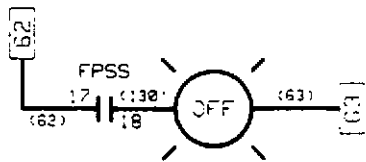

OPTION 8C - BYPASS TONE TIMER (PBEN)

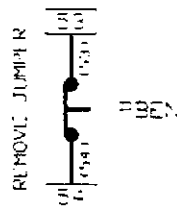

OPTION 8D - BYPASS TONE TIMER (PBDE)

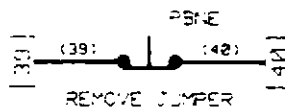

- OPTION 12C - NORMAL POSITION LIGHT (NL)  
INDICATES LOAD IS CONNECTED TO NORMAL

SUPPLIED AS STANDARD

- OPTION 12D - EMERGENCY POSITION LIGHT (EL)  
INDICATES LOAD IS CONNECTED TO EMERGENCY

SUPPLIED AS STANDARD

- OPTION 12G - NORMAL SOURCE LIGHT (SN)  
INDICATES NORMAL SOURCE AVAILABLE

SUPPLIED AS STANDARD

- OPTION 12H - EMERGENCY SOURCE LIGHT (SE)  
INDICATES EMERGENCY SOURCE AVAILABLE

SUPPLIED AS STANDARD

- OPTION 12L - NORMAL TRIPPED INDICATOR (TN)  
INDICATES OVERLOAD TRIP ON NORMAL

NOTE: ONLY AVAILABLE WHEN OPTION 11F IS SUPPLIED

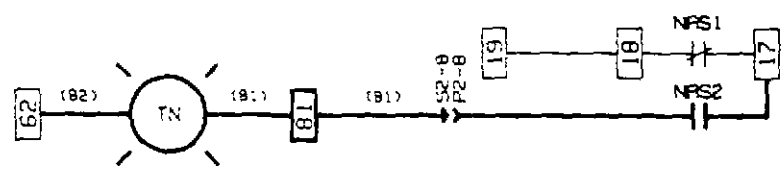

- OPTION 12M - EMERGENCY TRIPPED INDICATOR (TE)  
INDICATES OVERLOAD TRIP ON EMERGENCY

NOTE: ONLY AVAILABLE WHEN OPTION 11F IS SUPPLIED

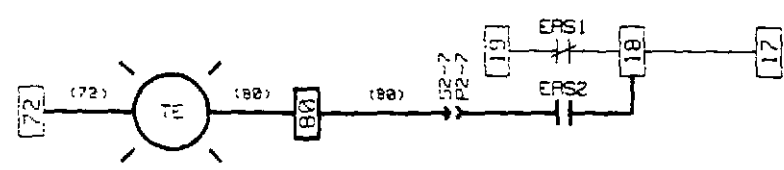

OPTION 14C - NORMAL AUXILIARY RELAY (NRA)  
 PROVIDES ADDITIONAL RELAY CONTACTS ON NORMAL

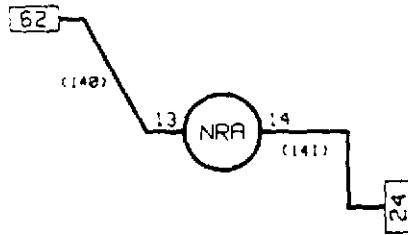

NOTE: CUSTOMER CONTACTS ARE ON RELAY SOCKET  
 SEE SOCKET DIAGRAM BELOW

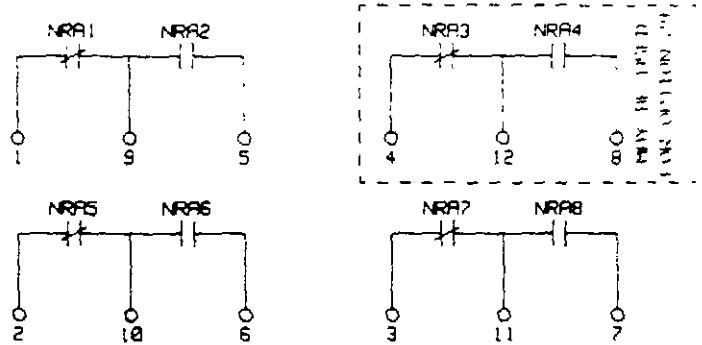

OPTION 14D - EMERGENCY AUXILIARY RELAY (ERA)  
 PROVIDES ADDITIONAL RELAY CONTACTS ON EMERGENCY



NOTE: CUSTOMER CONTACTS ARE ON RELAY SOCKET  
 SEE SOCKET DIAGRAM BELOW

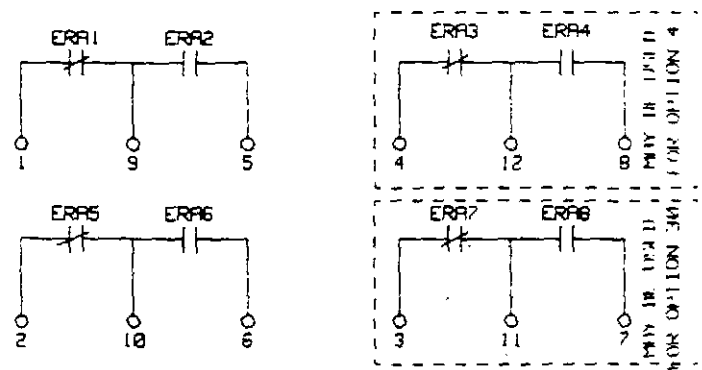

NRA - ERA SOCKET DIAGRAM

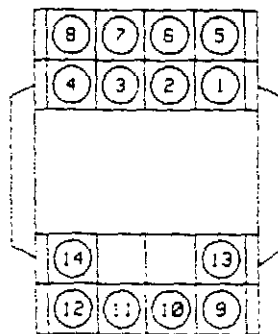

OPTION 18E - VOLTMETER

	HANDLE POSITION					
	NORMAL			EMERGENCY		
	1-3	2-3	1-2	1-2	2-3	1-3
1 — 2				X	X	X
3 — 4	X	X				
5 — 6					X	X
7 — 8		X				
9 — 10						X
11 — 12	X					
13 — 14				X	X	
15 — 16		X	X			

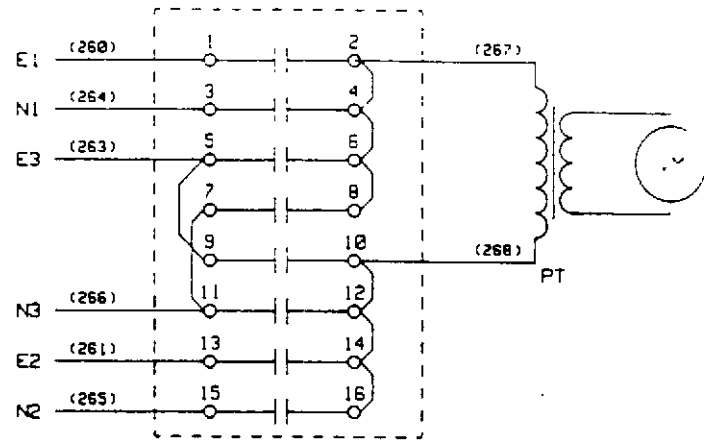

OPTION 18F - AMMETER

	HANDLE POSITION					
	OFF	1	2	3		
1 — 2	X			X	X	X
3 — 4	X	X		X	X	X
5 — 6	X			X	X	X
7 — 8				X	X	X
9 — 10				X	X	X
11 — 12	X	X	X	X	X	X

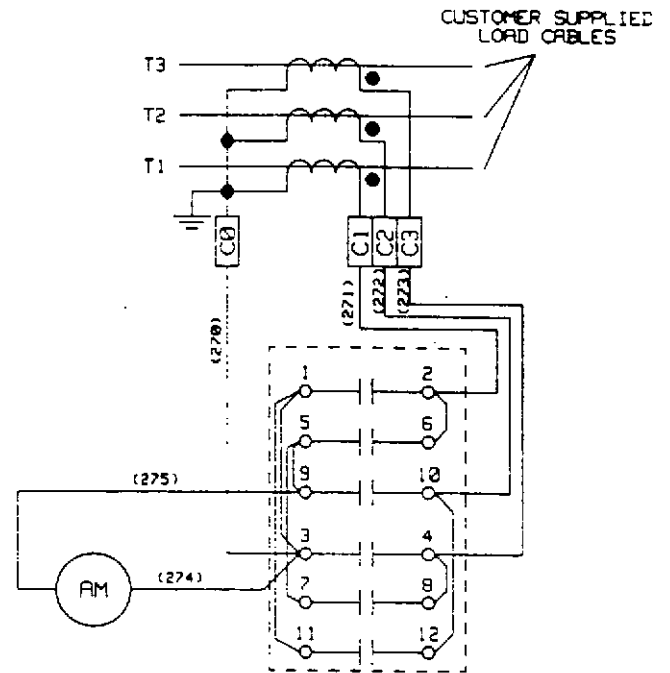

OPTION 18G - FREQUENCY METER

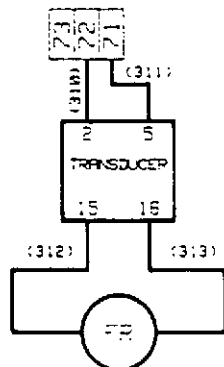

OPTION 18H - RUNNING TIME METER

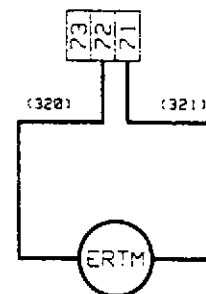

OPTION 23C - PLANT EXERCISER  
 RUN ENGINE AT SPECIFIED TIME  
 (NO LOAD)

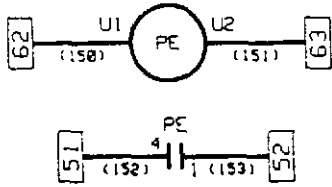

PE TERMINAL BLOCK

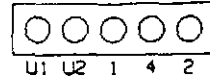

OPTION 23I = 23D W/FAILSAFE  
 OPTION 23J = 23G W/FAILSAFE

OPTION 23D - PLANT EXERCISER  
 RUN ENGINE AT SPECIFIED TIME  
 (LOAD)

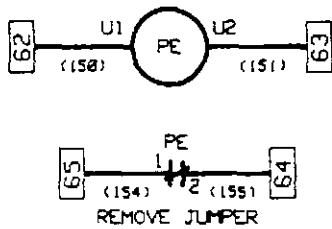

FAILSAFE CIRCUIT

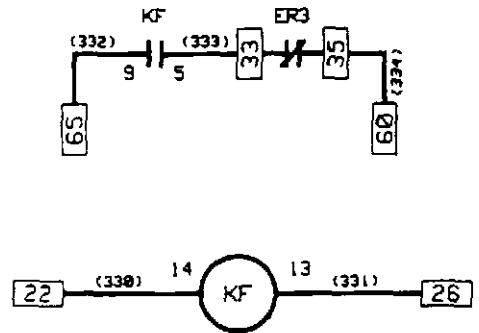

OPTION 23G - PLANT EXERCISER  
 RUN ENGINE AT SPECIFIED TIME  
 (SWITCH SELECTABLE  
 LOAD OR NO LOAD)

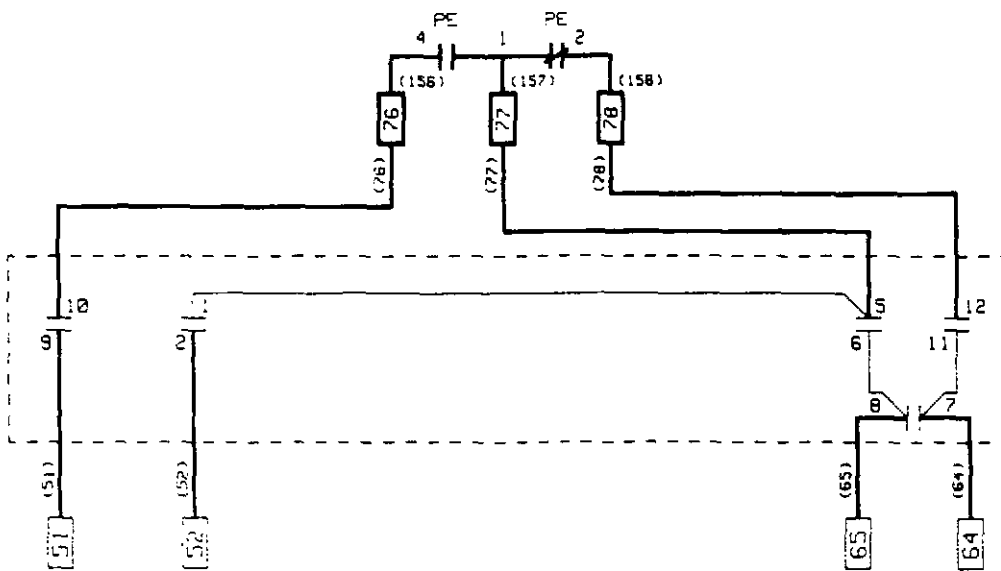

REMOVE JUMPER 64-65

	ENGINE RUN	BYPASS	LOAD TEST
1 — 2	X		
5 — 6			X
7 — 8	X	X	
9 — 10	X	X	
11 — 12			X

OPTION 28A - INTELLIGENCE CIRCUIT FUSES  
FUSES NON-ESSENTIAL CIRCUITRY ONLY

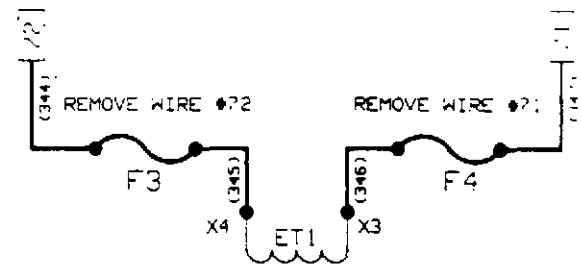
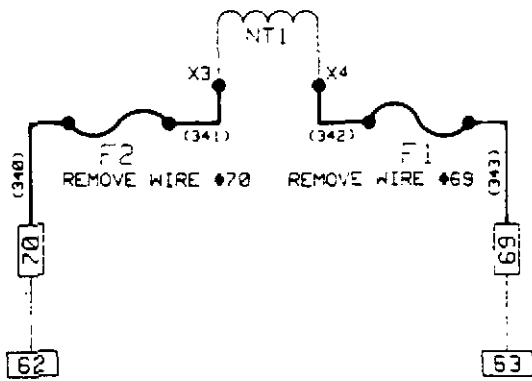

OPTION 33A - SHUNT TRIP  
(NORMAL)

OPTION 33B - SHUNT TRIP  
(EMERGENCY)

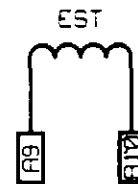
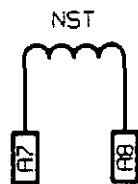

OPTION 28E - MANUAL RETURN TO NORMAL IMPUL

REQUIRES OPTION 140  
 OPTION 3 MAY NOT BE USED

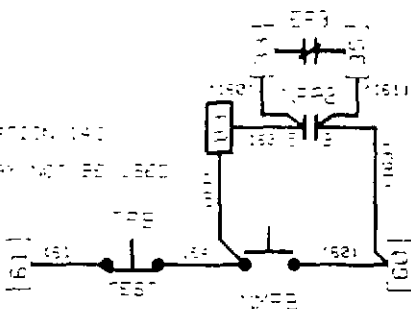

OPTION 28J AUTOMATIC/MANUAL RETURN TO NORMAL

REQUIRES OPTION 140

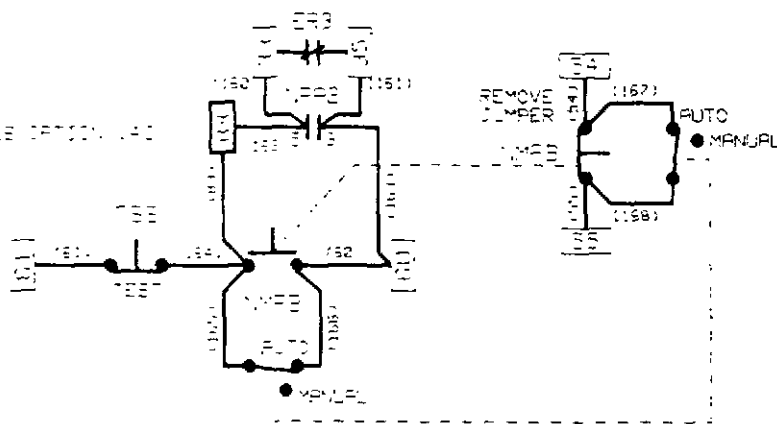

OPTION 28B - AUTOMATIC/MANUAL OPERATION

REQUIRES OPTION 140

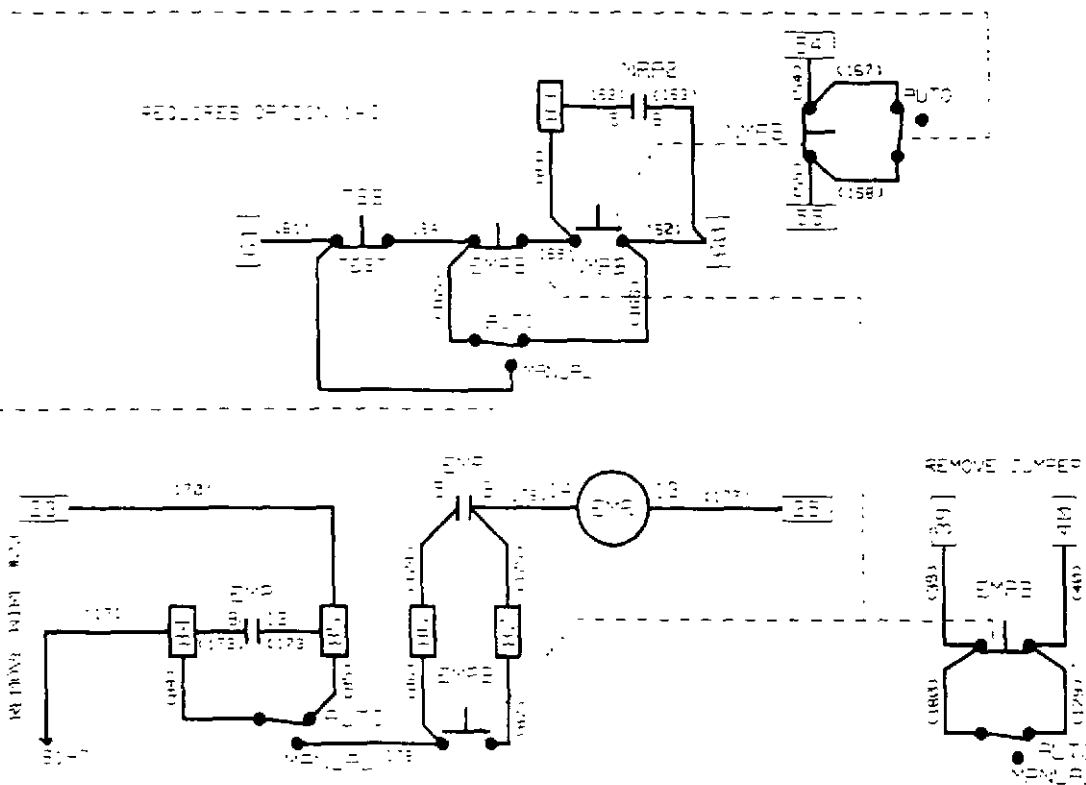

- OPTION 30 - TIME DELAY CRANK LIMITER (TDCL)  
INTERRUPTS ENGINE START CIRCUIT IF VOLTAGE DOES NOT APPEAR WITHIN A PRESELECTED TIME

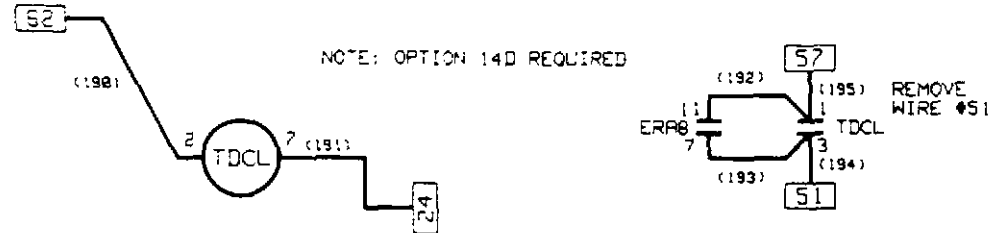

- OPTION 32A - TIME DELAY NEUTRAL (TDNC)  
PROVIDES A TIME DELAY IN THE NEUTRAL POSITION WHEN THE LOAD IS TRANSFERRED IN EITHER DIRECTION TO PREVENT EXCESSIVE INRUSH CURRENTS DUE TO OUT-OF-PHASE SWITCHING OF INDUCTIVE LOADS

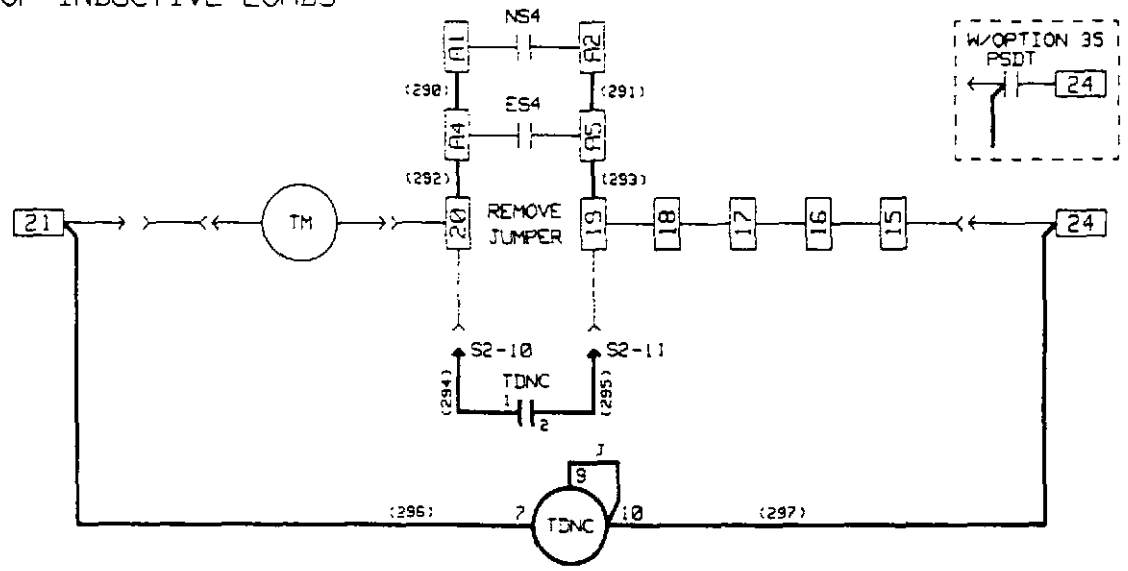

- OPTION 35A - PRETRANSFER SIGNAL DEVICE (PSD)  
RELAY CONTACTS CHANGE STATE PRIOR TO TRANSFER WITH PRESET TIME DELAY

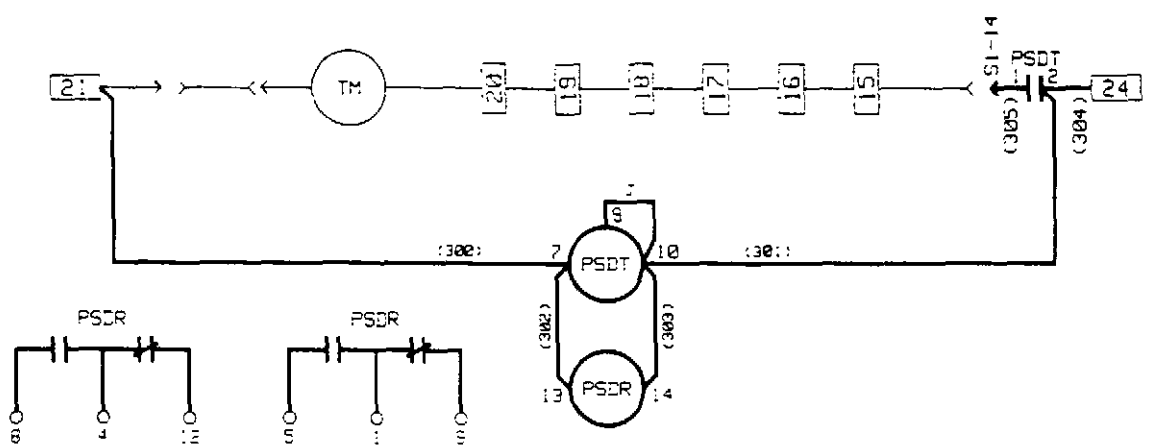

CUSTOMER CONTACTS ARE ON RELAY SOCKET

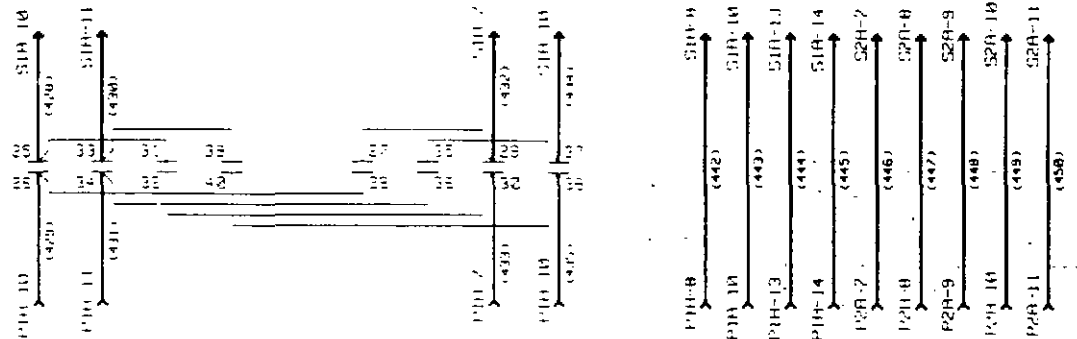
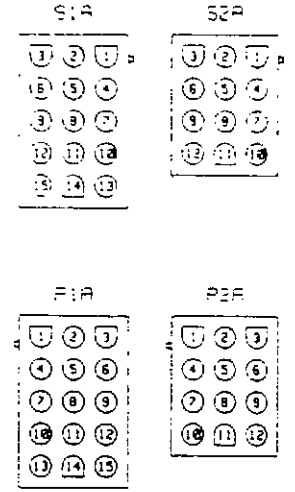
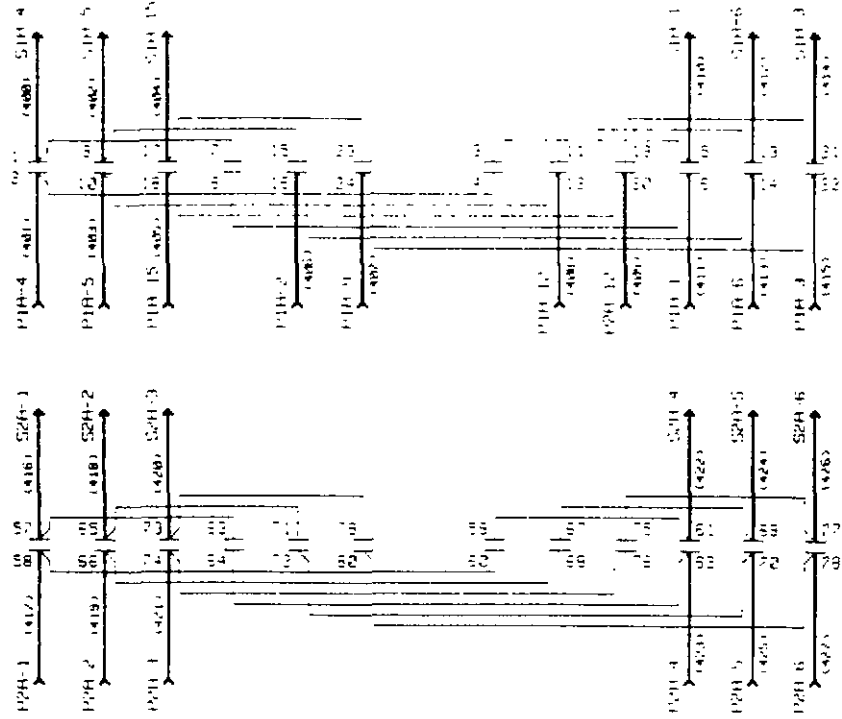

1	2	3	4	5	6	7	8	9	10	11	12	13	14	15	16	17	18	19	20	21	22	23	24	25	26	27	28	29	30	31	32	33	34	35	36	37	38	39	40	41	42	43	44	45	46	47	48	49	50	51	52	53	54	55	56	57	58	59	60	61	62	63	64	65	66	67	68	69	70	71	72	73	74	75	76	77	78	79	80
---	---	---	---	---	---	---	---	---	----	----	----	----	----	----	----	----	----	----	----	----	----	----	----	----	----	----	----	----	----	----	----	----	----	----	----	----	----	----	----	----	----	----	----	----	----	----	----	----	----	----	----	----	----	----	----	----	----	----	----	----	----	----	----	----	----	----	----	----	----	----	----	----	----	----	----	----	----	----	----

ROUTING  
PAGE

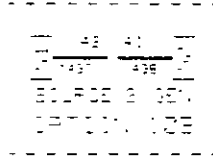
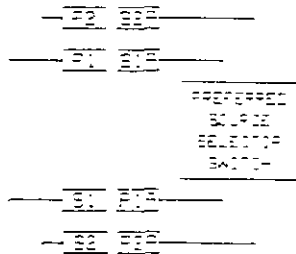

INTELLIGENCE  
PAGE

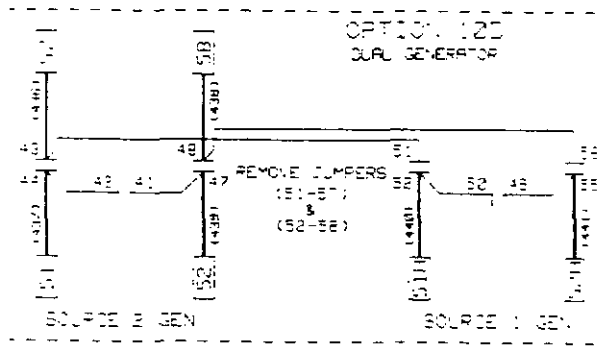

WESTINGHOUSE BYPASS/ISOLATION TRANSFER SWITCH  
Legend for Wiring Diagram Symbols

Symbol	Description
AM	Ammeter
Ex	Power Terminal, Emergency Source (x = Terminal Number)
EASx	Emergency Lockout (x = contact number)
EC	Engine Cooloff Relay Coil
ECx	Engine Cooloff Relay Contact (x = contact number)
EL	Emergency Position Indicator Light
ELS	Emergency Limit Switch
EMPB	Emergency Pushbutton for Manual Operation
EMR	Emergency Relay (Manual Operation)
ER	Emergency Relay Coil
ERx	Emergency Relay Contact (x = contact number)
ERA	Emergency Auxiliary Relay Coil
ERAx	Emergency Auxiliary Relay Contact (x = Contact Number)
ERTM	Generator Run Time Meter
EST	Emergency Shunt Trip
ESx	Emergency Auxiliary Switch (x = contact number)
ET1	Emergency Transformer (Line Voltage to 120vac - 2 windings)
ET2	Emergency Transformer (120 to 24vac CT)
ET3	Emergency Transformer (Line Voltage to 12vac)
ET4	Emergency Transformer (Line Voltage to 12vac)
FPSS	Four Position Selector Switch (Option 7)
FR	Frequency Meter
Fx	Fuse (x = Fuse Number)
KF	Failsafe Relay
KV	Voting Relay
MSS	Maintenance Selector Switch
NASx	Normal Lockout (x = contact number)
Nx	Power Terminal, Normal (x = Terminal number)
NL	Normal Position Indicator Light
NLS	Normal Limit Switch
NMPB	Normal Pushbutton for Manual Operation
NR	Normal Relay Coil
NRx	Normal Relay Contact (x = contact number)
NRA	Normal Auxiliary Relay Coil
NRAx	Normal Auxiliary Relay Contact (x = contact number)
NST	Normal Shunt Trip
NSx	Normal Auxiliary Switch (x = contact number)
NT1	Normal Transformer (Line Voltage to 120vac - 2 windings)
NT2	Normal Transformer (120 to 24vac CT)
NT3	Normal Transformer (Line Voltage to 12vac)
NT4	Normal Transformer (Line Voltage to 12vac)
Px-y	Plug (x = number, y = Terminal number)
PBEN	Bypass TDEN Pushbutton
PBNE	Bypass TDNE Pushbutton
PBRE	Pushbutton Reset Emergency Trip
PBRN	Reset Normal Breaker Trip Pushbutton
PE	Plant Exerciser
PSDR	Pre-Transfer Signal Device Relay
PSDT	Pre-Transfer Signal Device Timer
PSS	Preferred Source Selector Switch
Sx-y	Socket (x = number, y = Terminal number)
SDL	Service Disconnect Light
SDSS	Service Disconnect Selector Switch
SE	Emergency Source Available Indicator Light
SN	Normal Source Available Indicator Light
Lx	Power Terminal, Load (x = Terminal Number)
TDCL	Time Delay Crank Time Limiter
TDEC	Time Delay Engine Cool Down
TDEN	Time Delay Emergency to Normal
TDES	Time Delay Engine Start
TDNC	Time Delay Neutral
TDNE	Time Delay Normal to Emergency
TE	Emergency Trip Indicator Light
TM	Transfer Motor and Brake
TN	Normal Trip Indicator Light
TPB	Test Pushbutton
TSS	Test Selector Switch
VM	Voltmeter

**BYPASS ISOLATION SWITCH  
WITH  
AUTOMATIC TRANSFER SWITCH  
WIRING DIAGRAMS**

SPB  
Catalog Number **ATSBI** Only  
Solid State Transfer Switch

Shop Order:

Westinghouse Electric Corporation  
Electrical Components Division  
250 Westinghouse Drive  
London, KY 40741

(C) Copyright 1990, 1991 by Westinghouse Electric Corporation  
All Rights Reserved

ATSBI-WD V1.1 8-5-91

WESTINGHOUSE SPB AUTOMATIC TRANSFER SWITCH  
WIRING DIAGRAMS

DIRECTIONS FOR USE  
-----

The drawing package can be used as a point to point diagram for maintenance and diagnostic purposes for the SPB type Transfer Switch, all ratings.

This document contains the following wiring information:

Page 1 Intelligence Panel wiring exclusive of added option functions.

Page 2 Power section wiring exclusive of added option functions.

Pages 3 - 18 Wiring for optional functions

Page 19 Legend Sheet, describing symbols used throughout the document.

Note: Unnumbered sheets may be added to this document on specific occasions to illustrate custom option additions per order instructions.

All SPB type transfer switches will be standardly wired as indicated by Pages 1 and 2. The Intelligence Panel, and the Power Section are interconnected via keyed plug/socket connectors (P1-S1/P2-S2). Your specific unit may be equipped with certain optional functions as noted which require additional wiring as shown on pages 3 - 18.

Note: BOLD LINES on the option wiring indicate components and wiring added to the basic wiring diagram to accomplish that specific option-function.

Necessary design changes may alter the indicated diagrams. If in doubt contact the factory.

## Westinghouse Automatic Transfer Switch

### Standard Features

The following features are included as Standard on all Automatic Switches.

- TEST SELECTOR SWITCH - Simulates a power failure in the logic. Will cause Generator to start, and load to transfer to the Emergency Source.
- UNDERVOLTAGE PROTECTION ON NORMAL (All Phases)  
Monitors the NORMAL Source. Should the voltage drop below a pre-set Dropout, the generator is started and transfer to the Emergency Source takes place.
- ENGINE START CONTACT - Contact that provides a closure to Engine control when Normal Source fails.
- LOGIC DISCONNECT - Plugs provided to disconnect the logic circuitry for maintenance.
- MOTOR DISCONNECT - Plug provided to disconnect motor circuit for testing of logic circuitry without transfer.
- AUXILIARY CONTACTS - Auxiliary contacts integral to the switching devices rated at 120V 18A, for customer use. These may be applied to customer specified options.
- VOLTAGE SELECTION PLUG -  
Westinghouse unique feature which allows field selection of system voltage to which switch will be connected.
- FULLY RATED NEUTRAL - A fully rated solid neutral is supplied on all two and three pole switches. All four pole switches are supplied with switched neutral contacts of identical construction and rating as the power poles.

# SPB ATS INTELLIGENCE PANEL

DRAWOUT TYPE SPB TRANSFER SWITCH

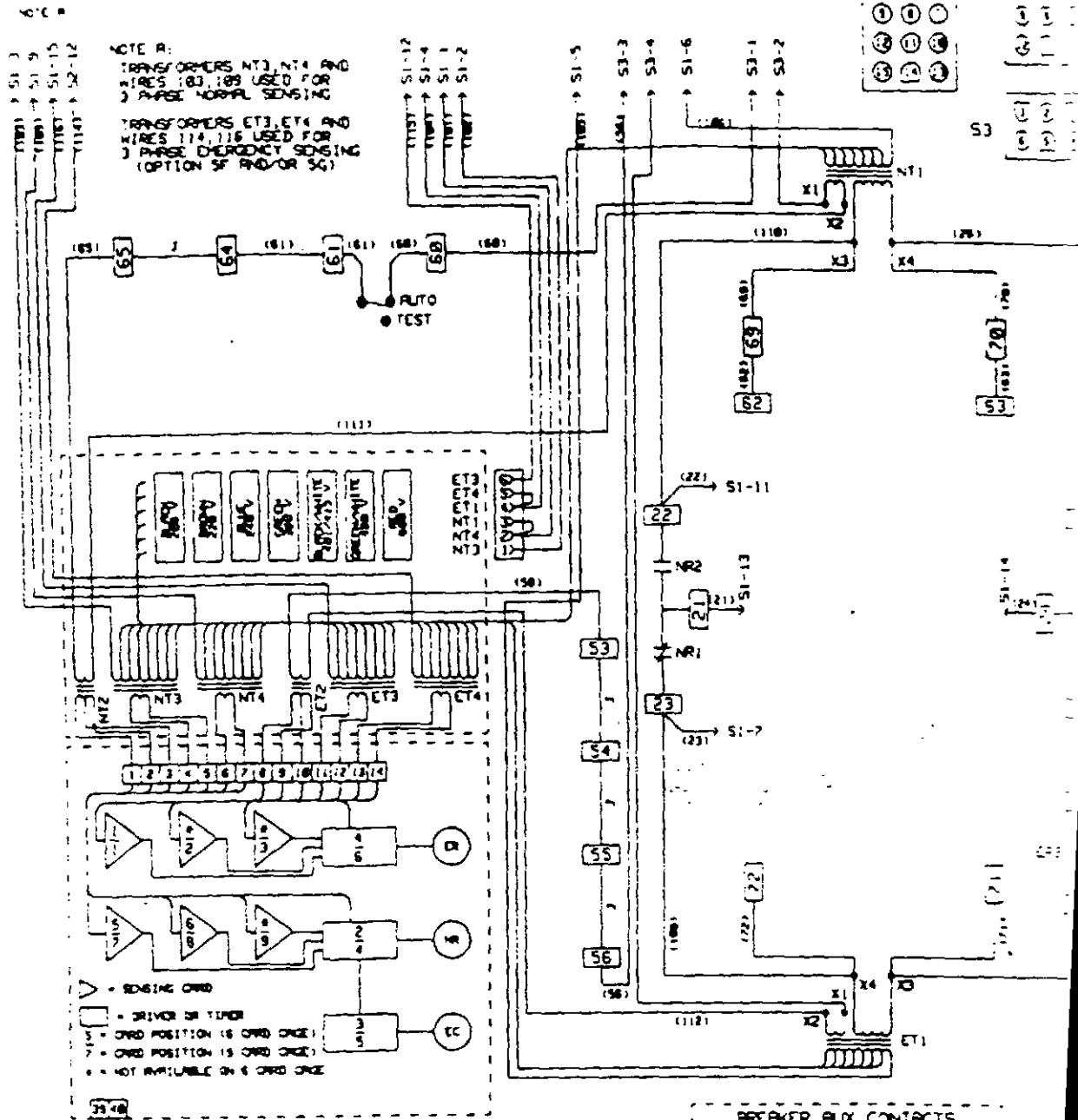

NOTE A:  
 1 TRANSFORMERS NT3, ET4  
 2 Wires 183, 189 USED FOR 2  
 3 PHASE NORMAL SENSING  
 4 TRANSFORMERS ET3, ET4  
 5 Wires 174, 176 USED FOR 2  
 6 PHASE EMERGENCY SENSING  
 (OPTION 5F AND/OR 5G)

- ▷ SENSING OVER
- ▷ DRIVE IN TIME
- ▷ OVER POSITION IS OVER ONE
- ▷ OVER POSITION IS OVER ONE
- ▷ NOT AVAILABLE ON 6 OVER ONE

ENGINE	SPB	SPB	SPB
PL.	SPB	SPB	SPB
RUN	OFF	OFF	OFF
TEST	TEST	TEST	TEST
AUTO	AUTO	AUTO	AUTO

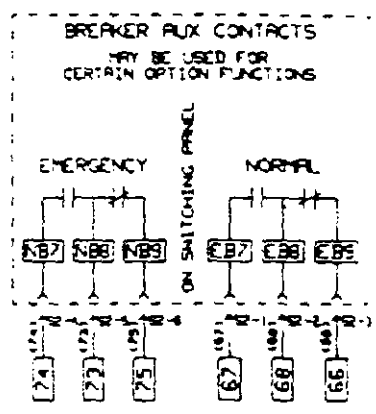
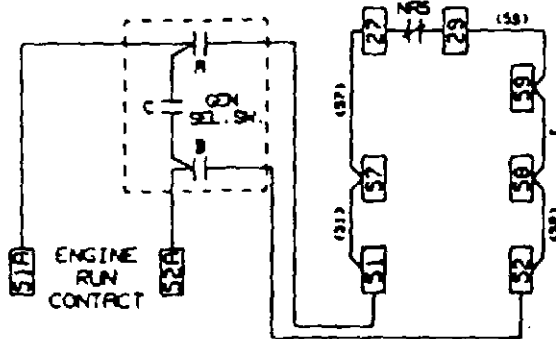



# SPB POWER SWITCHING PANEL (ORPAOUT TYPE)

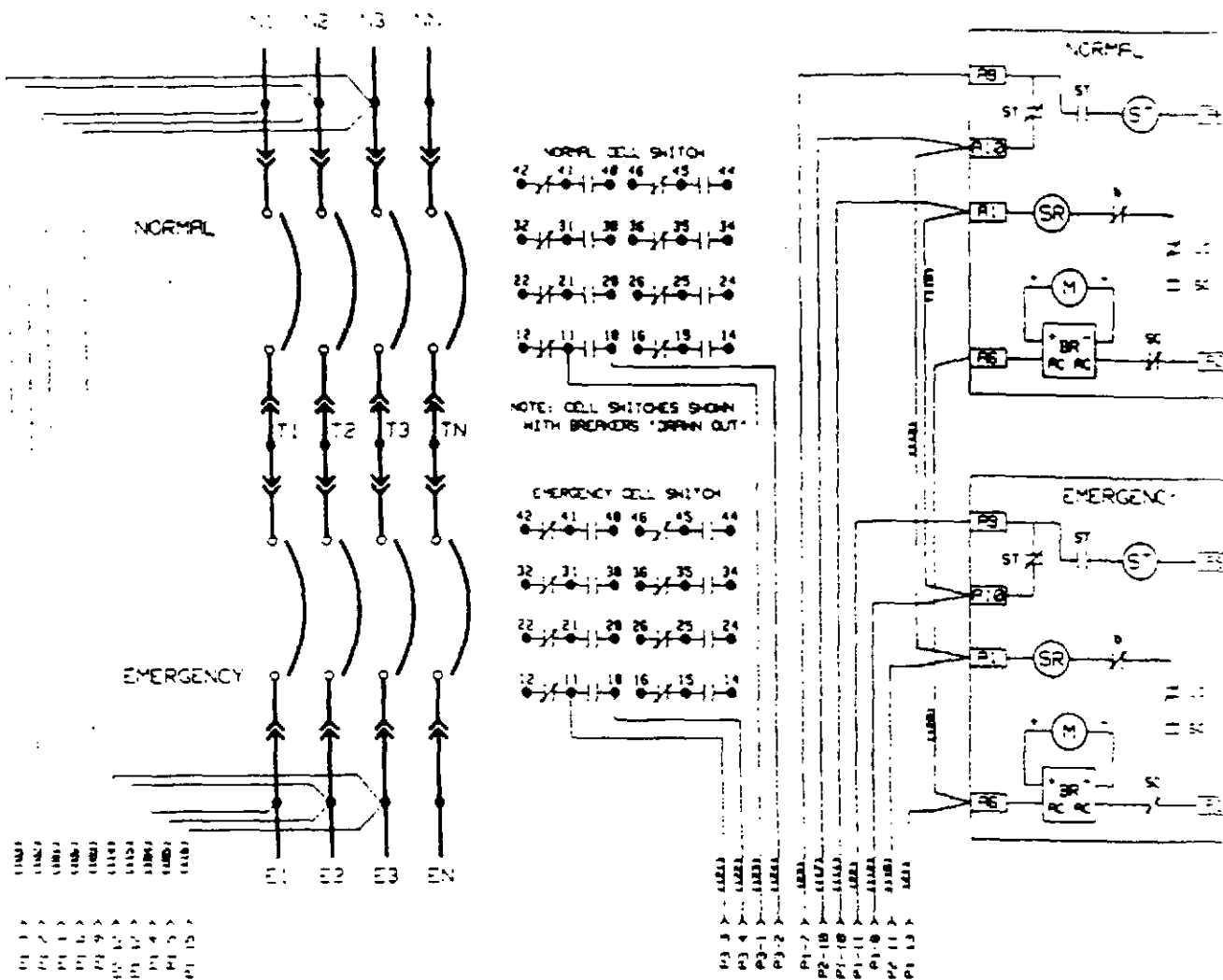

- 11A1
- 11A2
- 11A3
- 11A4
- 11A5
- 11A6
- 11A7
- 11A8
- 11A9
- 11A10
- 11A11
- 11A12
- 11A13
- 11A14
- 11A15

- 11A1
- 11A2
- 11A3
- 11A4
- 11A5
- 11A6
- 11A7
- 11A8
- 11A9
- 11A10
- 11A11
- 11A12
- 11A13
- 11A14
- 11A15

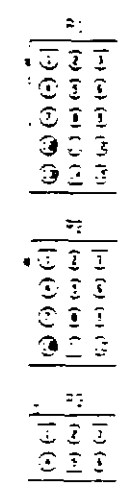
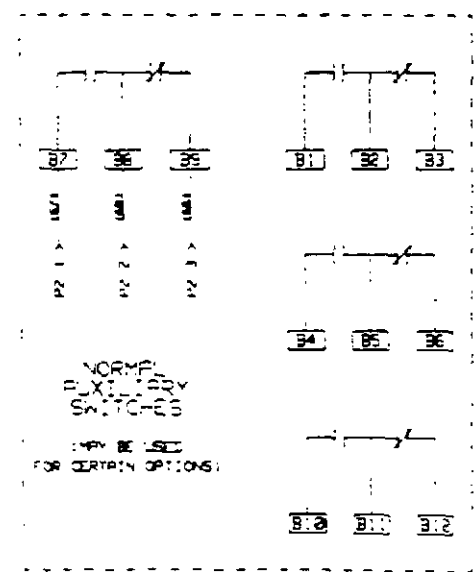
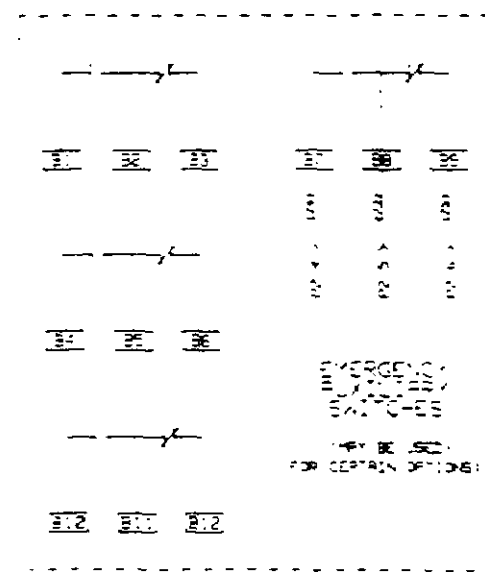

# BYPASS/ISOLATION SWITCH POWER WIRING

NOTE: POWER CONNECTIONS AS SHOWN ARE FOR DIAGRAM PURPOSES

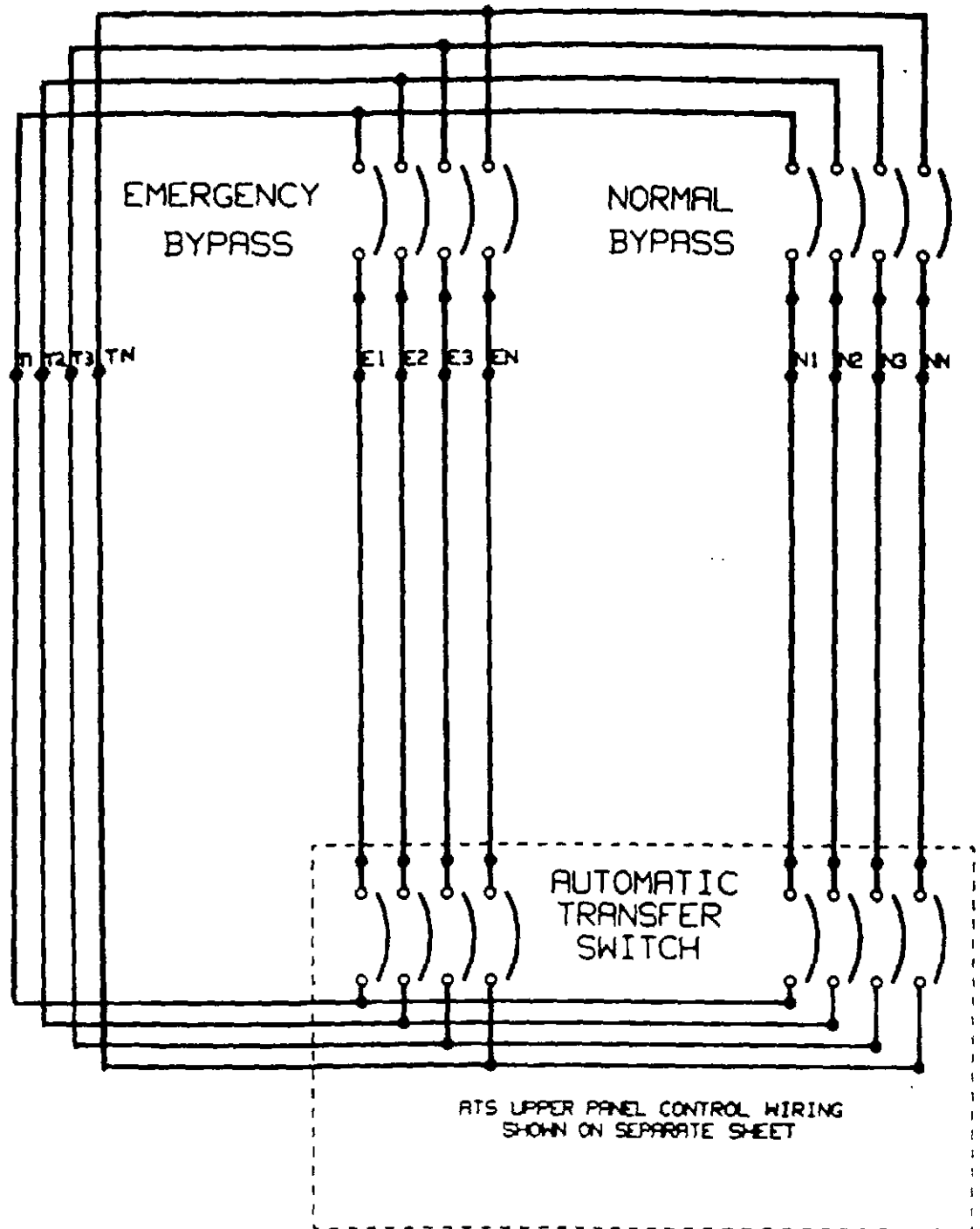



6 POSITION CARD CAGE

	NORMAL	ENG.	EMERGENCY		
	2	3	4	5	6
UNDERVOLTAGE	STD				
DRIVER	(OPTION 3)				
BLANK	(OPTION 4)				
DRIVER	(OPTION 1)				
BLANK	(OPTION 5)				
BLANK	(OPTION 5)				



9 POSITION CARD CAGE

	NORMAL			ENG.	EMERGENCY		
	2	3	4	5	6	7	8
UNDERVOLTAGE	STD						
BLANK	(OPTION 26)						
BLANK	(OPTION 26)						
DRIVER	(OPTION 3)						
BLANK	(OPTION 4)						
DRIVER	(OPTION 1)						
BLANK	(OPTION 5)						
BLANK	(OPTION 5)						
BLANK	(OPTION 5)						



OPTION 1 - TIME DELAY NORMAL TO EMERGENCY (TDNE)

6 POSITION CARD CAGE  
 REPLACE DRIVER CARD IN POSITION 4  
 WITH TIMER CARD

9 POSITION CARD CAGE  
 REPLACE DRIVER CARD IN POSITION 5  
 WITH TIMER CARD



OPTION 3 - TIME DELAY EMERGENCY TO NORMAL (TDEN)

6 POSITION CARD CAGE  
 REPLACE DRIVER CARD IN POSITION 2  
 WITH TIMER CARD

9 POSITION CARD CAGE  
 REPLACE DRIVER CARD IN POSITION 4  
 WITH TIMER CARD



OPTION 4 - TIME DELAY ENGINE COOLOFF (TDEC)

6 POSITION CARD CAGE  
 REPLACE BLANK CARD IN POSITION 3  
 WITH A TIMER CARD  
 ADD EC RELAY TO MOTHERBOARD

9 POSITION CARD CAGE  
 REPLACE BLANK CARD IN POSITION 5  
 WITH A TIMER CARD  
 ADD EC RELAY TO MOTHERBOARD

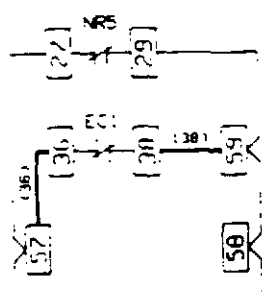

OPTION 4 ONLY

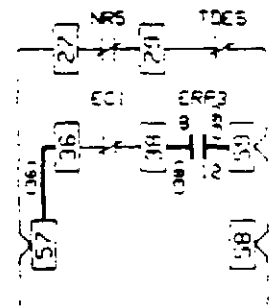

OPTION 4 WITH 2 \*\*  
 \*\* REQUIRES OPTION 140



OPTION 5 - EMERGENCY SENSING (OV,UF,OF)

6 POSITION CARD CAGE  
 REPLACE BLANK CARD IN POSITION 5 OR 6  
 WITH APPROPRIATE SENSING CARD

9 POSITION CARD CAGE  
 REPLACE BLANK CARD IN POSITION 7, 8 OR 9  
 WITH APPROPRIATE SENSING CARD



OPTION 26 - NORMAL SENSING (OV,UF,OF)

6 POSITION CARD CAGE  
 NOT AVAILABLE

9 POSITION CARD CAGE  
 REPLACE BLANK CARD IN POSITION 2 OR 3  
 WITH APPROPRIATE SENSING CARD

\* UNDERVOLTAGE SENSING ON NORMAL IS STANDARD

OPTION 2 - TIME DELAY ENGINE START (TDES)

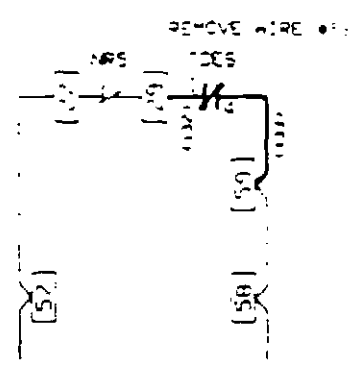
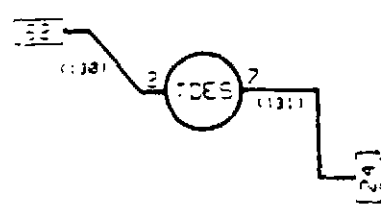

OPTION 6B - TEST PUSHBUTTON (TPB)

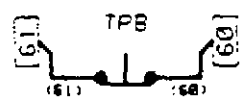

REPLACES STANDARD TEST SELECTOR SWITCH

OPTION 6H - FOUR POSITION SELECTOR SWITCH (FPSS)

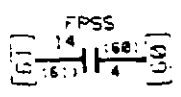

REPLACES STANDARD TEST SELECTOR SWITCH

FPSS	1-1 16T	1-1 12T	1-1 14T	1-1 13S 16T	1-1 11T
TEST	X	X	X	X	X
AUTO	X	X	X	X	X
OFF	X	X	X	X	X
ENG. RUN	X	X	X	X	X

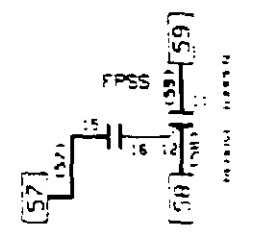
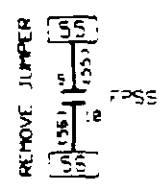
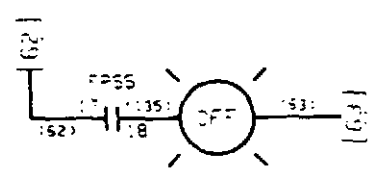

OPTION 8C - BYPASS TIEIN TIMER (PBEN)

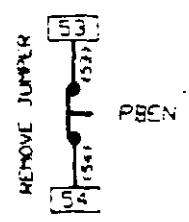

OPTION 8D - BYPASS TIME TIMER (PBNE)

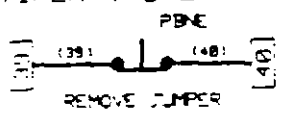

OPTION B - MAINTENANCE SELECTOR SWITCH

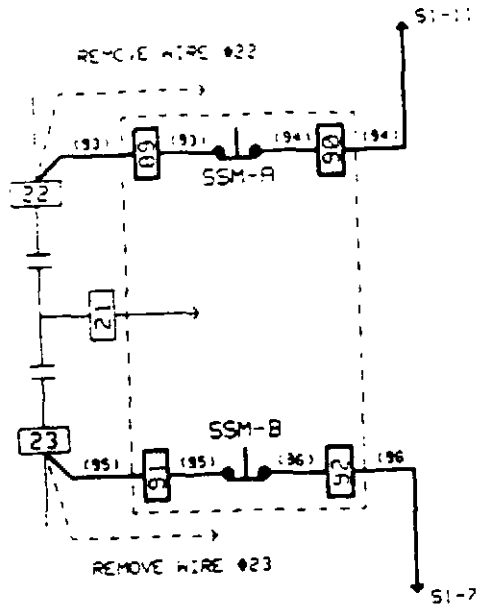

- OPTION 12C - NORMAL POSITION LIGHT (NL)  
INDICATES LOAD IS CONNECTED TO NORMAL

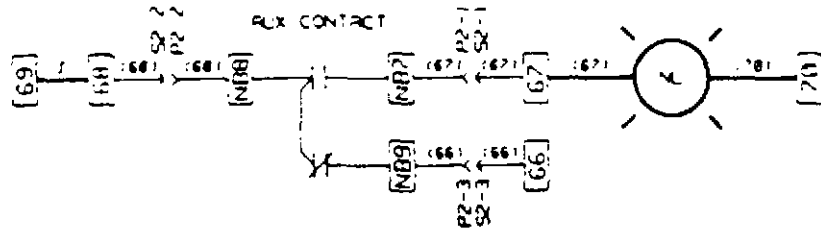

- OPTION 12D - EMERGENCY POSITION LIGHT (EL)  
INDICATES LOAD IS CONNECTED TO EMERGENCY

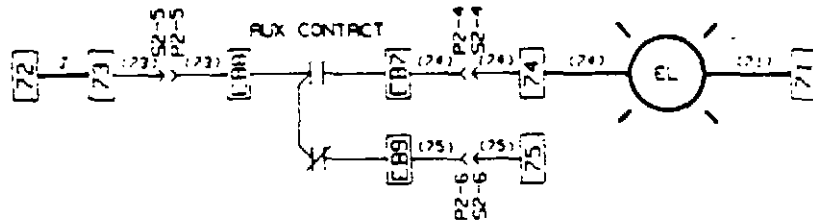

- OPTION 12G - NORMAL SOURCE LIGHT (SN)  
INDICATES NORMAL SOURCE AVAILABLE

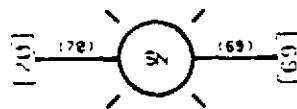

- OPTION 12H - EMERGENCY SOURCE LIGHT (SE)  
INDICATES EMERGENCY SOURCE AVAILABLE

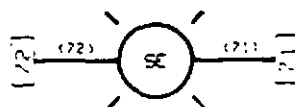



OPTION 14C - NORMAL AUXILIARY RELAY (NRA)  
PROVIDES ADDITIONAL RELAY CONTACTS ON NORMAL

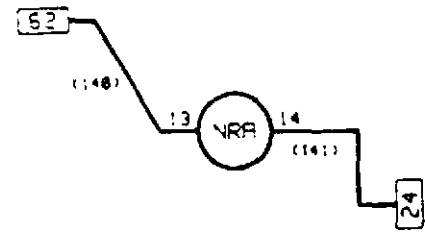

NOTE: CUSTOMER CONTACTS ARE ON RELAY SOCKET  
SEE SOCKET DIAGRAM BELOW

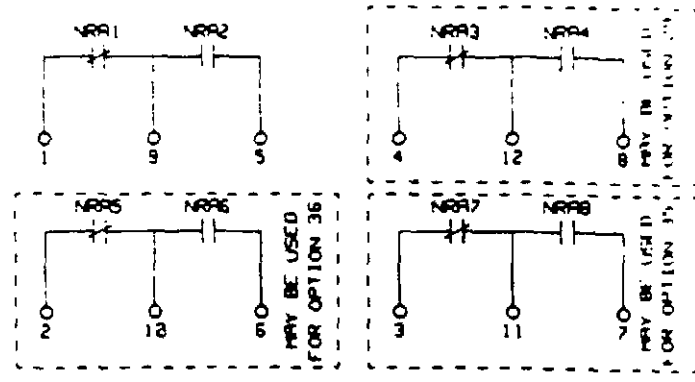

OPTION 14D - EMERGENCY AUXILIARY RELAY (ERA)  
PROVIDES ADDITIONAL RELAY CONTACTS ON EMERGENCY



NOTE: CUSTOMER CONTACTS ARE ON RELAY SOCKET  
SEE SOCKET DIAGRAM BELOW

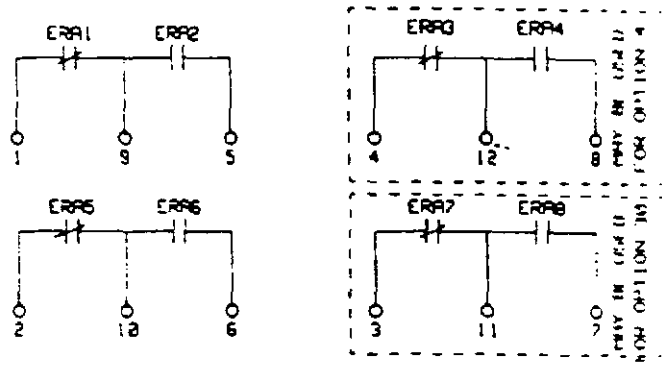

NRA - ERA SOCKET DIAGRAM

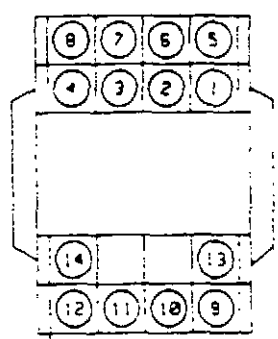

OPTION 18E - VOLTMETER

		HANDLE POSITION					
		NORMAL 1-3 2-3 1-2			EMERGENCY 1-2 2-3 1-3		
1	2					X	X
3	4	X	X				
5	6					X	X
7	8		X	X			
9	10						X
11	12	X	X				
13	14					X	X
15	16		X	X	X		

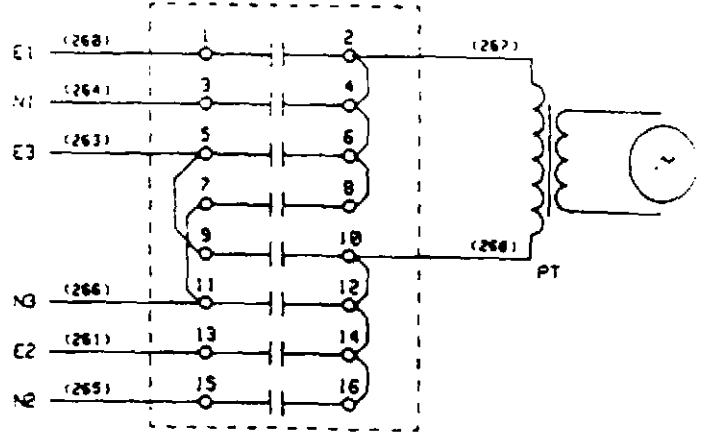

OPTION 18F - AMMETER

		HANDLE POSITION			
		OFF	1	2	3
1	2	X	X	X	X
3	4	X	X	X	X
5	6	X	X	X	X
7	8	X	X	X	X
9	10	X	X	X	X
11	12	X	X	X	X

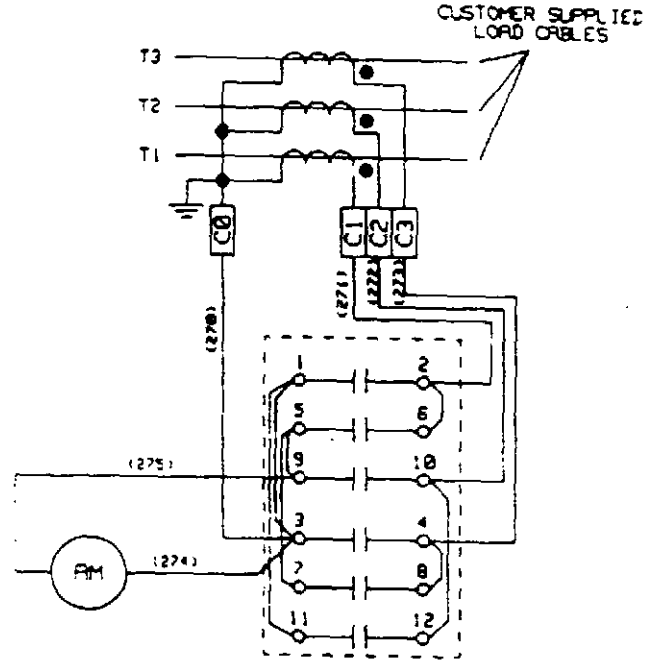

OPTION 18G - FREQUENCY METER

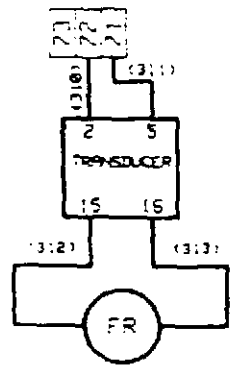

OPTION 18H - RUNNING TIME METER

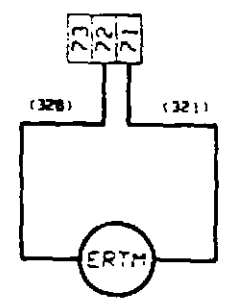

OPTION 230 - PLANT EXERCISER  
 RUN ENGINE AT SPECIFIED TIME  
 (NO LOAD)

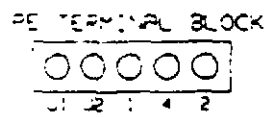
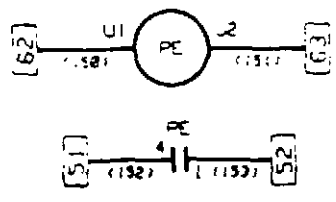

OPTION 231 = 230 W/FAILSAFE

OPTION 233 = 230 W/FAILSAFE

OPTION 23D - PLANT EXERCISER  
 RUN ENGINE AT SPECIFIED TIME  
 (LOAD)

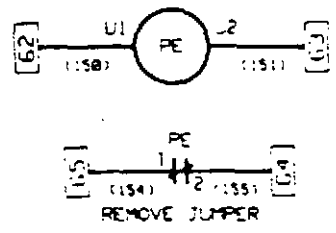

FAILSAFE CIRCUIT

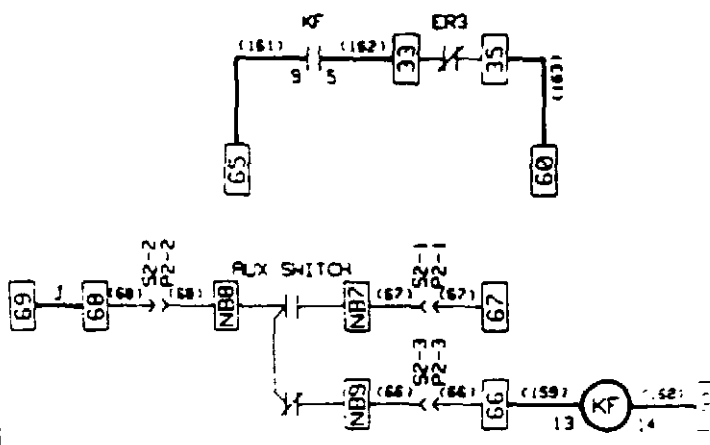

OPTION 23G - PLANT EXERCISER  
 RUN ENGINE AT SPECIFIED TIME  
 (SWITCH SELECTABLE  
 LOAD OR NO LOAD)

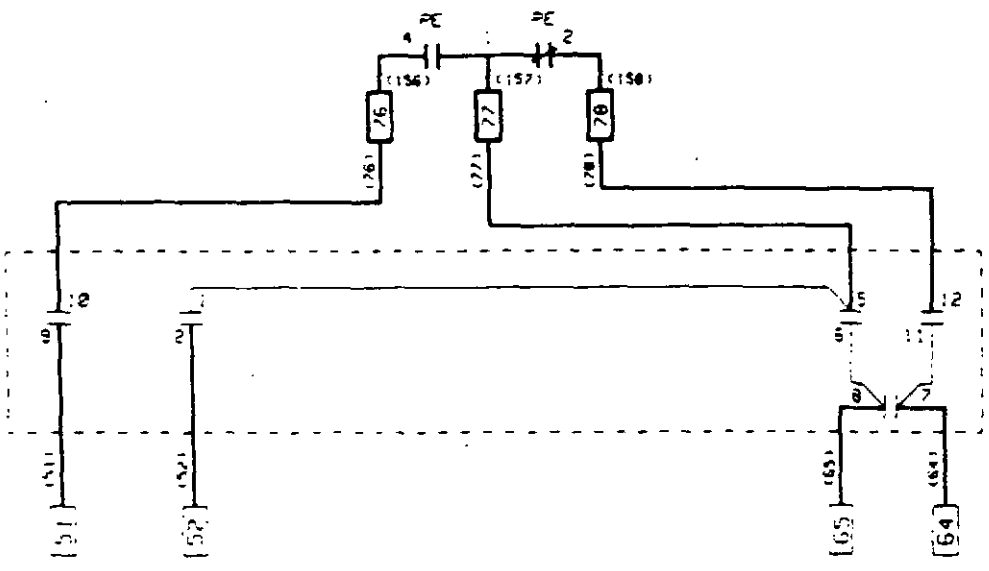
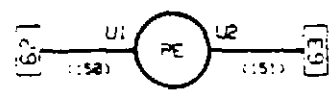

	ENGINE RUN	BYPASS
1	X	
5		X
7	X	X
9	X	X
11		X

BLOCK JUMPER 6-65

OPTION 28A - INTELLIGENCE CIRCUIT FUSES  
FUSES NON-ESSENTIAL CIRCUITS ONLY

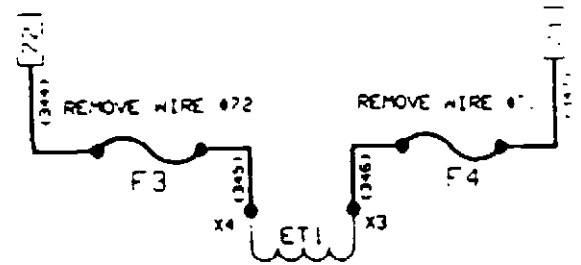
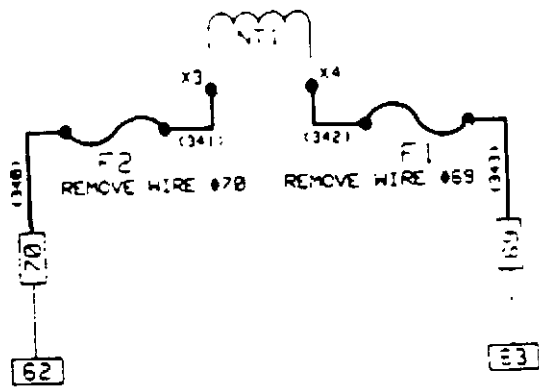

OPTION 30 - TIME DELAY CRANK LIMITER (TDCL)  
INTERUPTS ENGINE START CIRCUIT IF VOLTAGE DOES  
NOT APPEAR WITHIN A PRESELECTED TIME

NOTE: OPTION 143 REQUIRED

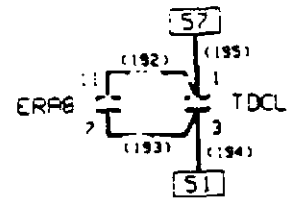
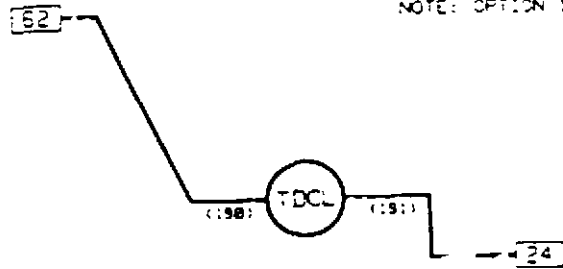

OPTION 29E - MANUAL RETURN TO NORMAL (NMPB)

REQUIRES OPTION 14C  
OPTION 3 MAY NOT BE USED

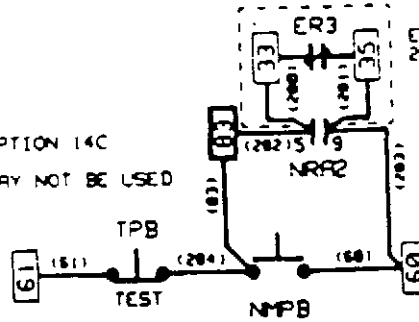

ELIMINATE IF OPTIONS 23I OR 23J ARE USED

OPTION 29J AUTOMATIC/MANUAL RETURN TO NORMAL

REQUIRES OPTION 14C

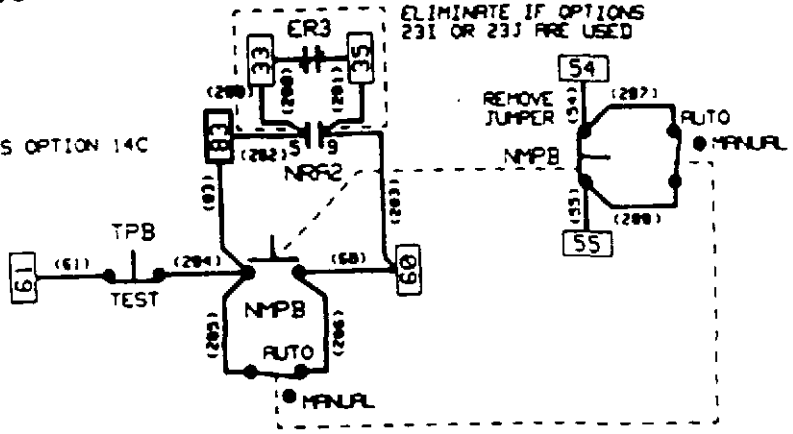

ELIMINATE IF OPTIONS 23I OR 23J ARE USED

OPTION 29G - AUTOMATIC/MANUAL OPERATION

REQUIRES OPTION 14C

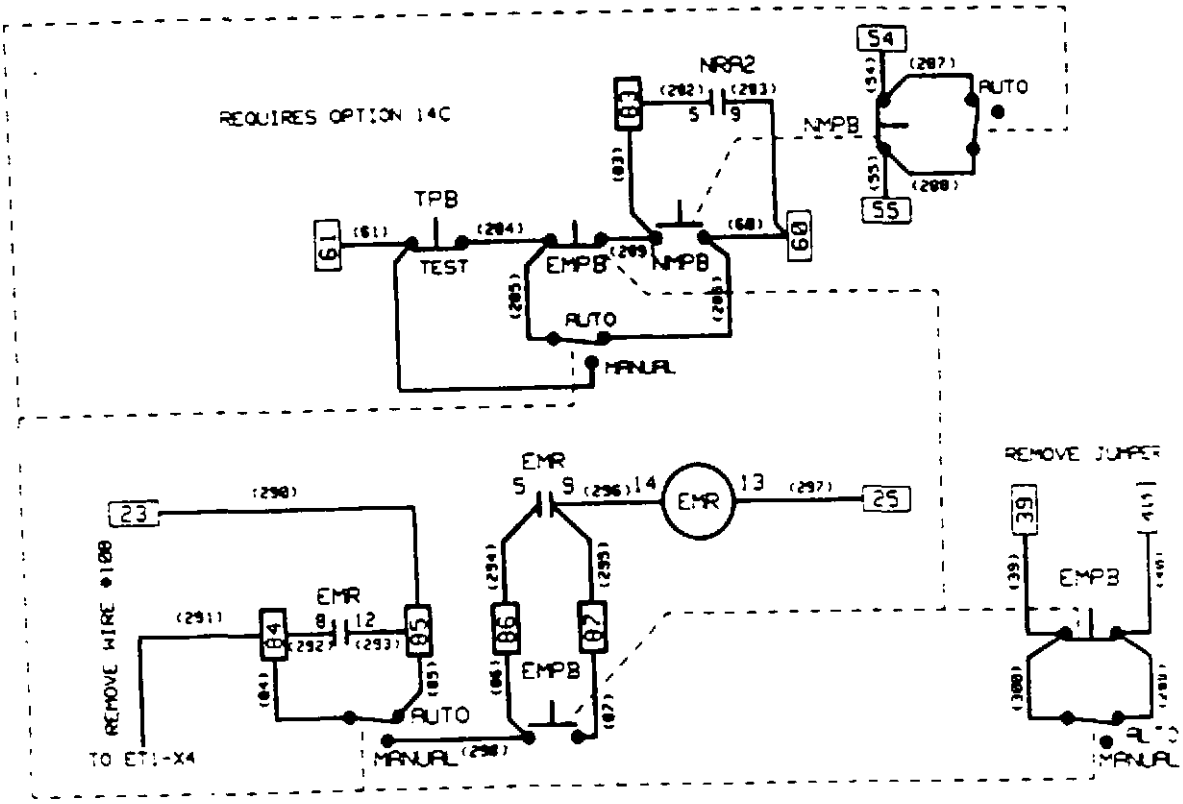

REMOVE JUMPER

REMOVE WIRE #108  
TO ET1-X4

OPTION 16 - SUB DIGITAL

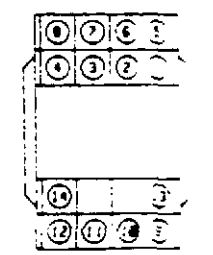
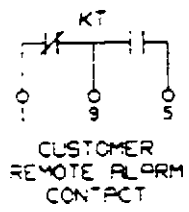
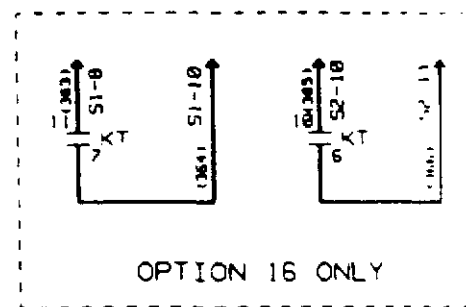
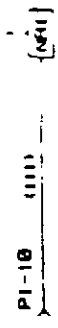
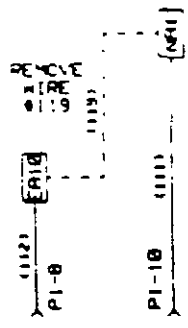
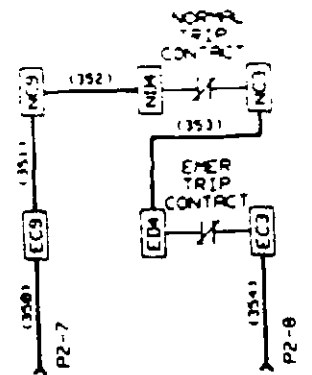
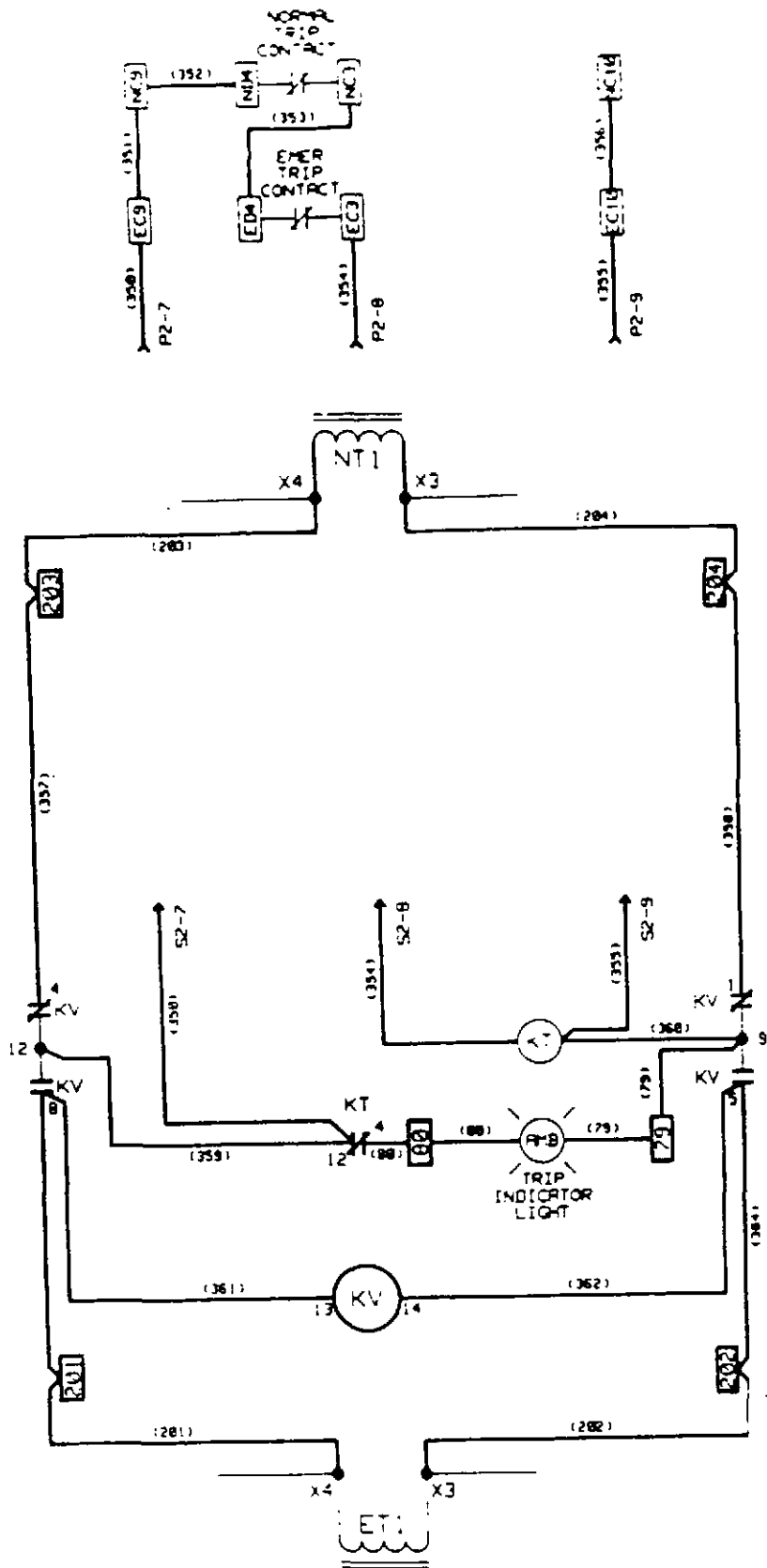

KT RELAY SOCKET

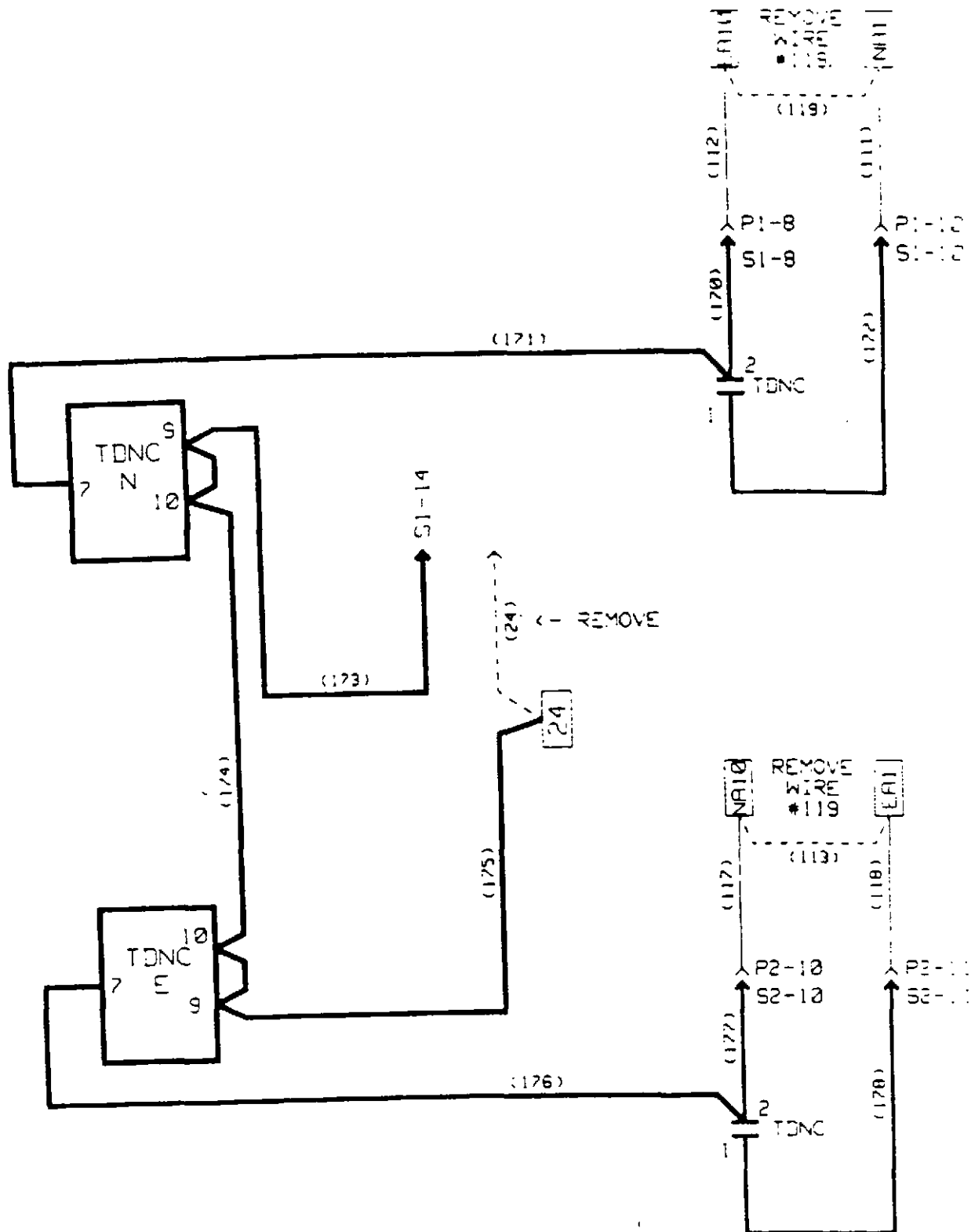



# OPTION 35 - PRETRANSFER SIGNAL DEVICE

(OPTION 14 REQUIRED)

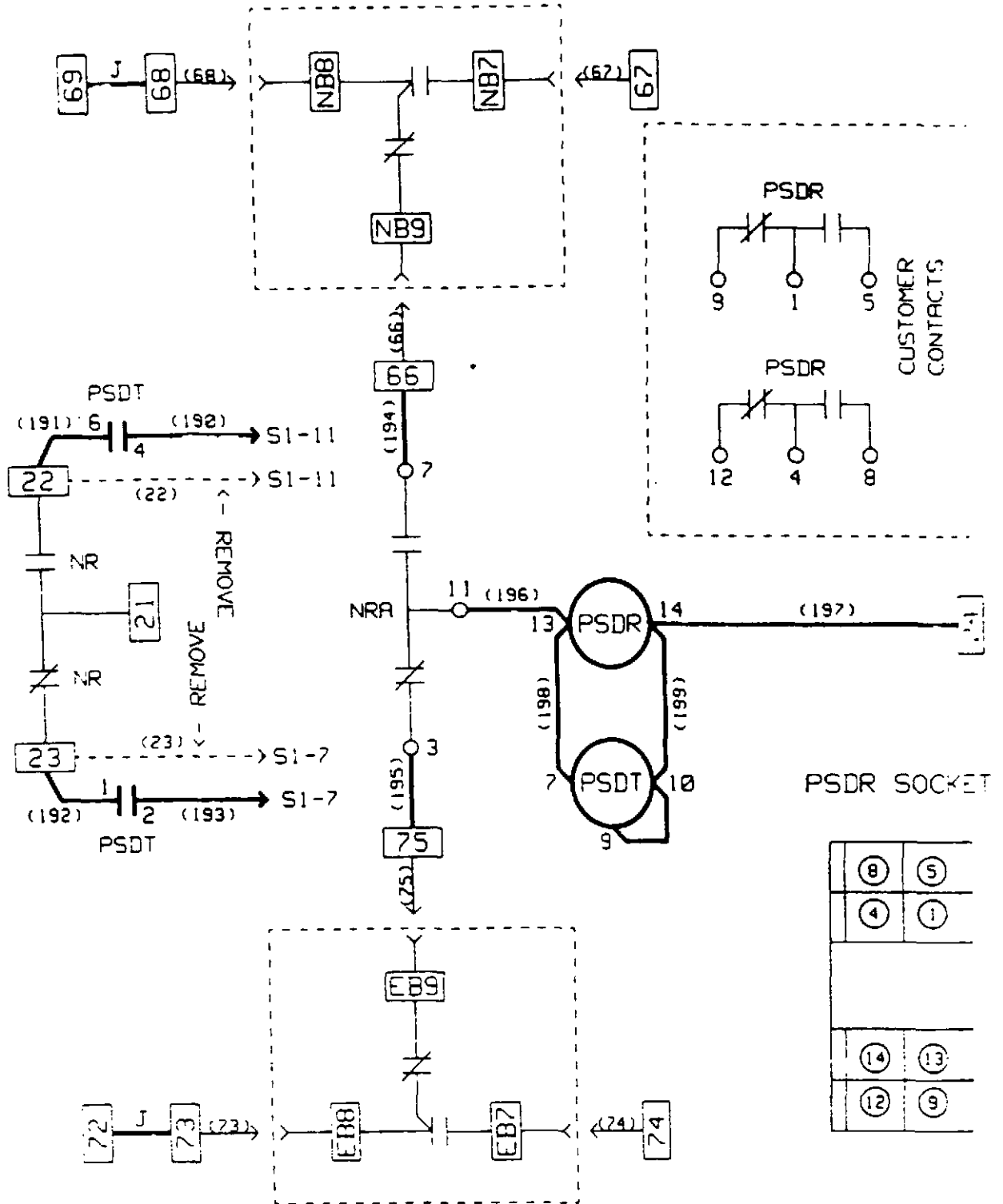

OPTION 36 - LOAD SHED

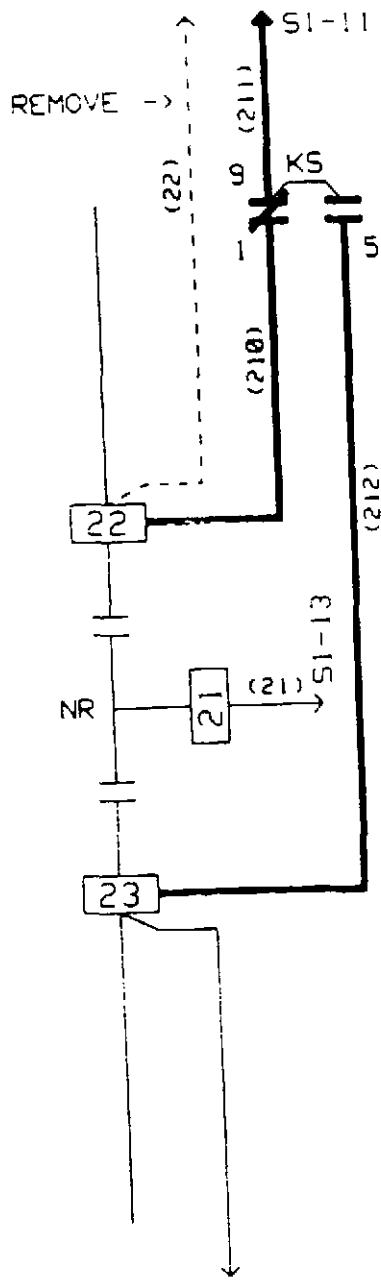

KS RELAY SOCKET

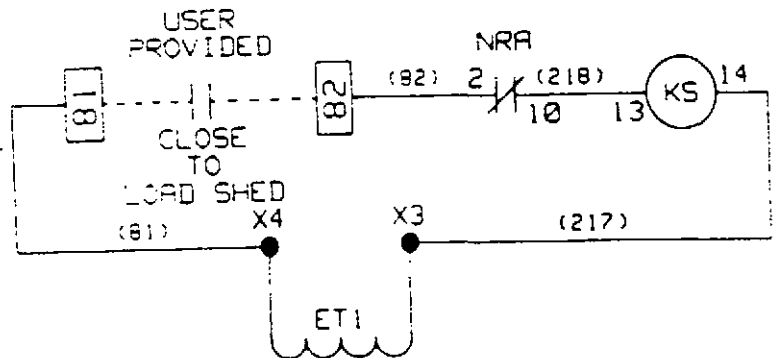
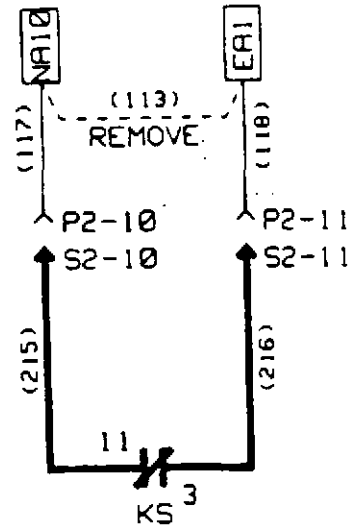
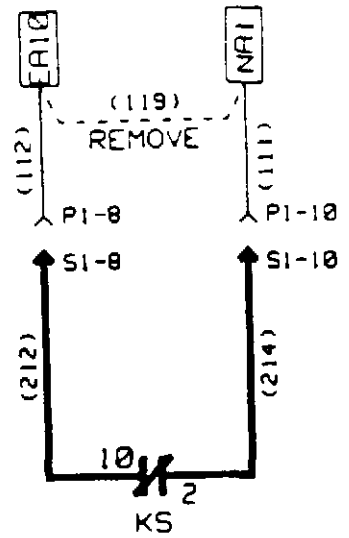
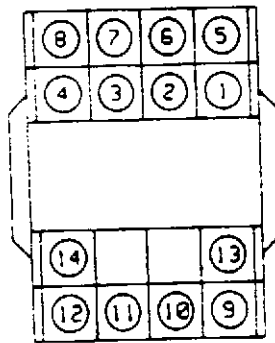

OPTION 37 - SERVICE ENTRANCE  
(INCLUDE OPTION 15)

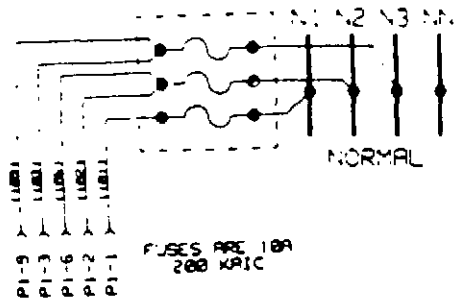

KV IS PROVIDED BY OPTION 15

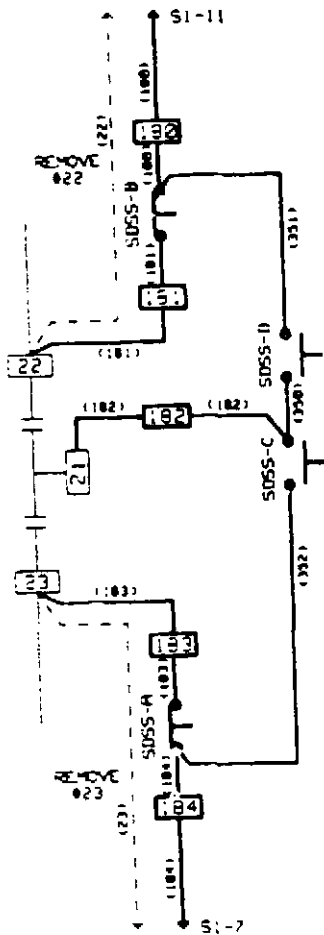
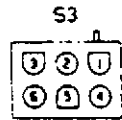
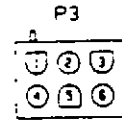
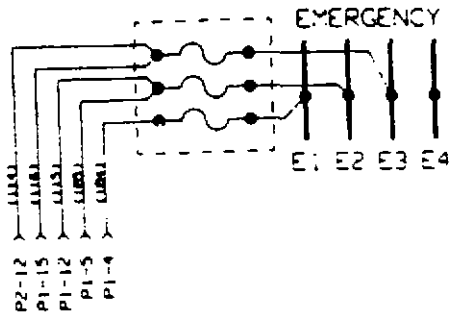
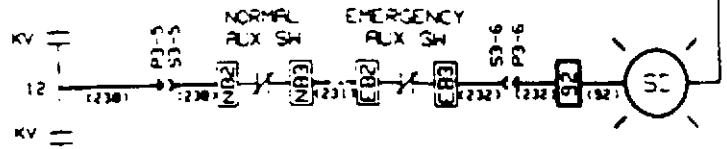

SERVICE DISCONNECT SW	E	B	O	D	E	L
DISCONNECT					X	X
ENERGIZE	X	X			X	X

KEY LOCKED  
KEY REMOVABLE  
IN "DISCONNECTED" POSITION

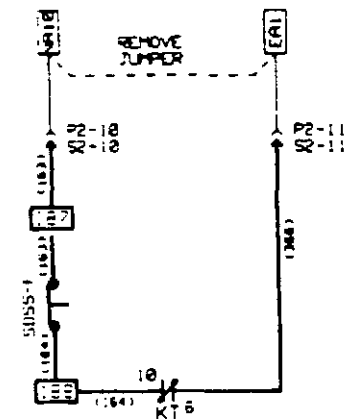
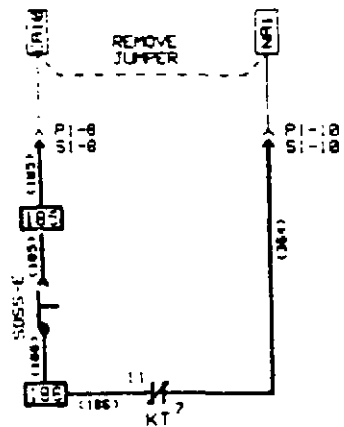

# COMBINATION WIRING

OPTIONS 16, 32, 36, 37, AND 37

THIS DRAWING SHOWS INTER WIRING OF THESE OPTIONS WHEN COMBINED

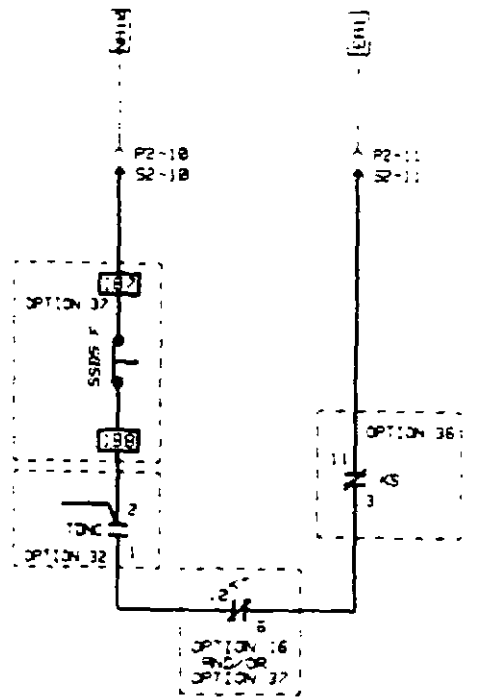
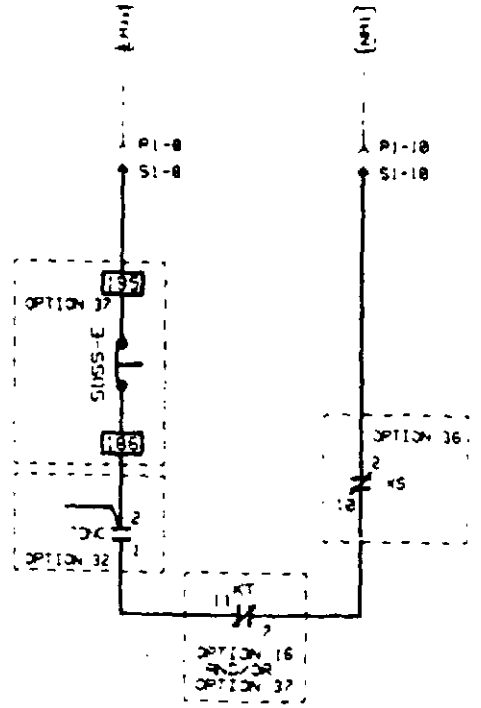
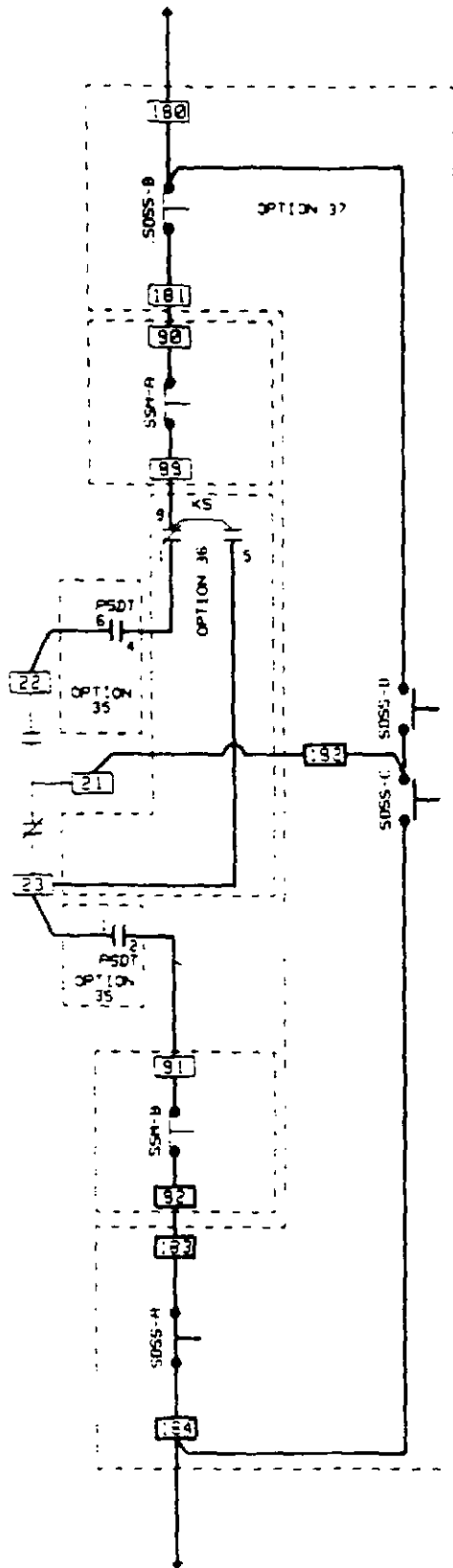



Westinghouse SPB Automatic Transfer Switch  
Legend for Wiring Diagram Symbols

Symbol	Description
AM	Ammeter
ETx	Power Terminal, Emergency Source (x = Terminal Number)
EASx	Emergency Lockout (x = contact number)
EC	Engine Cooloff Relay Coil
ECx	Engine Cooloff Relay Contact (x = contact number)
EL	Emergency Position Indicator Light
EMPB	Emergency Pushbutton for Manual Operation
EMR	Emergency Relay (Manual Operation)
ER	Emergency Relay Coil
ERx	Emergency Relay Contact (x = contact number)
ERA	Emergency Auxiliary Relay Coil
ERAx	Emergency Auxiliary Relay Contact (x = Contact Number)
ERTM	Generator Run Time Meter
ESx	Emergency Auxiliary Switch (x = contact number)
ET1	Emergency transformer (Line Voltage to 120vac - 2 windings)
ET2	Emergency transformer (120 to 24vac CT)
ET3	Emergency transformer (Line Voltage to 12vac)
ET4	Emergency transformer (Line Voltage to 12vac)
ESS	Four Position Selector Switch (Option 6A)
FR	Frequency Meter
Fx	Fuse (x = Fuse Number)
KS	Fail-safe Relay
KS	Load Shed Relay
KT	Trip Relay (Used w/Option 16)
KV	Voting Relay
MSS	Maintenance Selector Switch
NASx	Normal Lockout (x = contact number)
Nx	Power Terminal, Normal (x = Terminal number)
NL	Normal Position Indicator Light
NMPB	Normal Pushbutton for Manual Operation
NR	Normal Relay Coil
NRx	Normal Relay Contact (x = contact number)
NRA	Normal Auxiliary Relay Coil
NRAx	Normal Auxiliary Relay Contact (x = contact number)
NSx	Normal Auxiliary Switch (x = contact number)
NT1	Normal transformer (Line Voltage to 120vac - 2 windings)
NT2	Normal transformer (120 to 24vac CT)
NT3	Normal transformer (Line Voltage to 12vac)
NT4	Normal transformer (Line Voltage to 12vac)
Px-y	Plug (x = number, y = Terminal number)
PBEN	Bypass TDEN Pushbutton
PBNE	Bypass TDNE Pushbutton
PBRE	Pushbutton Reset Emergency Trip
PBRN	Reset Normal Breaker Trip Pushbutton
PE	Plant Exerciser
PSDR	Pre-Transfer Signal Device Relay
PSDT	Pre-Transfer Signal Device Timer
PSS	Preferred Source Selector Switch
CSx-y	Socket (x = number, y = Terminal number)
SDL	Service Disconnect Light
DSS	Service Disconnect Selector Switch
SD	Services Disconnected Light
SE	Emergency Source Available Indicator Light
SN	Normal Source Available Indicator Light
TX	Power Terminal, Load (x = Terminal Number)
TDCL	Time Delay Crank Time Limiter
TDEC	Time Delay Engine Cool Down
TDEN	Time Delay Emergency to Normal
TDES	Time Delay Engine Start
TDNC	Time Delay Neutral
TDNE	Time Delay Normal to Emergency
TE	Emergency Trip Indicator Light
TM	Transfer Motor and Brake
TN	Normal Trip Indicator Light
TPB	Test Pushbutton
TSS	Test Selector Switch
VM	Voltmeter

# **Cutler-Hammer Beaver, PA**

**Non-Automatic Transfer Switch**

**Type MTSRM Wiring Diagrams**

**Cutler-Hammer  
Power Distribution Components Division  
One Tuscarawas Road  
Beaver, PA 15009**

**Copyright 1995 by Eaton/Cutler-Hammer Inc.  
All Rights Reserved**

**Version 1.0 3-29-93**

# Cutler-Hammer Non-Automatic Transfer Switch Wiring Diagrams

## Directions for Use

The drawing package can be used as a point to point wiring diagram for maintenance and diagnostic purposes for Solid State Logic SPB Transfer Switches, all voltages.

This document contains the following wiring information:

**Page 1**

Basic Solid State Intelligence Panel Wiring exclusive of added option functions

**Page 2**

Power Switching Panel basic wiring exclusive of added option functions.

**Pages 3 - 7**

Wiring for optional functions

**Page 8 - 9**

Legend Sheet describing symbols used throughout this document

**Note:** Unnumbered sheets may be added to this document on specific occasions to illustrate custom options additions per order instructions.

As a standard, transfer switch units will be wired as indicated by Pages 1, and 2. The Intelligence Panel and Power Panel are interconnected via keyed plug/socket connectors (P1-S1/P2-S2). Your specific unit may be equipped with certain optional functions as noted which require additional wiring as shown on pages 3 - 18.

Wiring for optionally added functions will typically interface with the basic unit wiring (Pages 1-2) which should be used as the base reference.

**Note:** **BOLD** lines on option wiring indicate components and wiring added to the basic wiring diagram to accomplish that specific option function.

# Cutler-Hammer Automatic Transfer Switch

## Standard Features

### **Engine Start Contact**

Contact that provides a closure to Engine Controller when the NORMAL Source fails.

### **Logic Disconnect**

Plugs provided to disconnect the logic circuitry for maintenance purposes.

### **Auxiliary Contacts**

Auxiliary contacts integral to the switching devices rated at 120 VAC, 10 amps. These may be applied for customer use, and may be applied to certain customer specified options.

### **Fully Rated Neutral**

A fully rated solid neutral is supplied on all two and three pole switches. All four pole switches are supplied with switched neutral contacts of identical construction and rating as the power poles.

# SPB ATS INTELLIGENCE PANEL CATALOG MTSRM ONLY

NOTE A

NOTE A:  
 TRANSFORMERS NT3, NT4 AND WIRES 103, 109 USED FOR 3 PHASE NORMAL SENSING  
 TRANSFORMERS ET3, ET4 AND WIRES 114, 116 USED FOR 3 PHASE EMERGENCY SENSING (OPTION SF AND/OR SG)

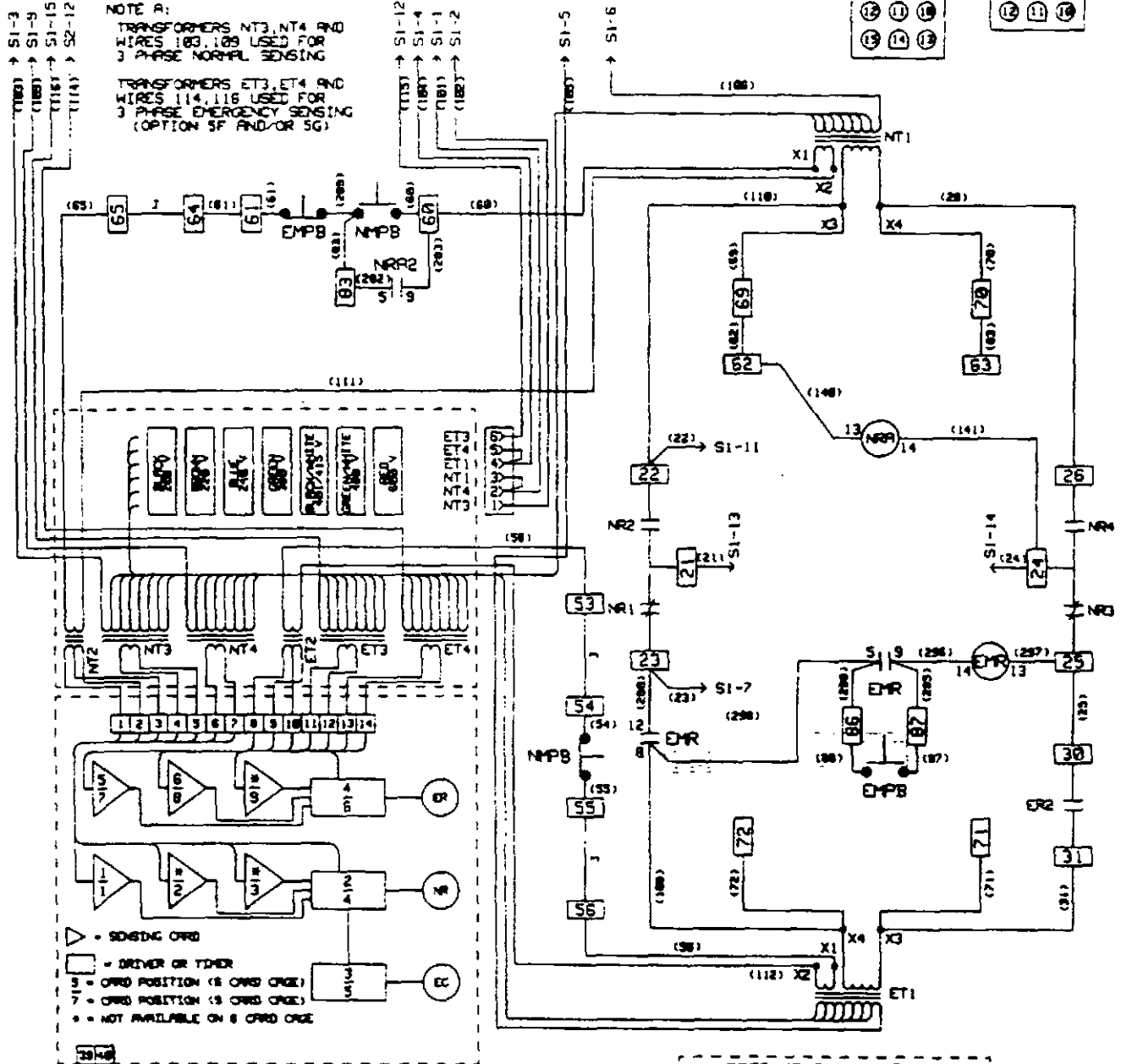

- ▷ SENSING CRD
- DRIVER OR TYPED
- CRD POSITION (S CRD CRG)
- CRD POSITION (S CRD CRG)
- NOT AVAILABLE ON S CRD CRG

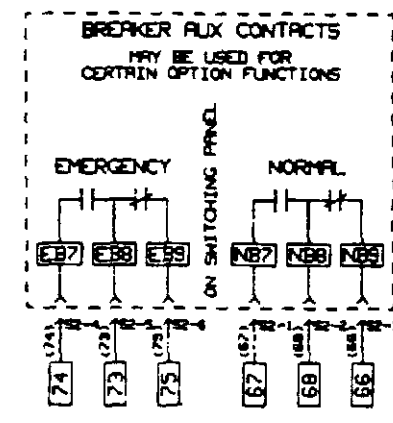
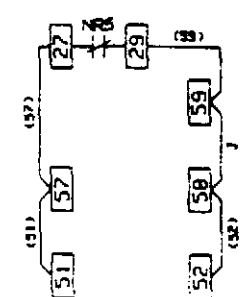

# SPB POWER SWITCHING PANEL (FIXED MOUNT)

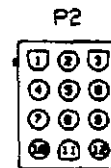
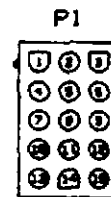
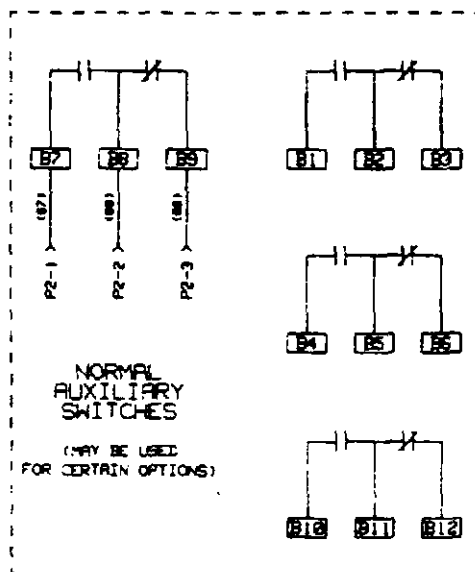
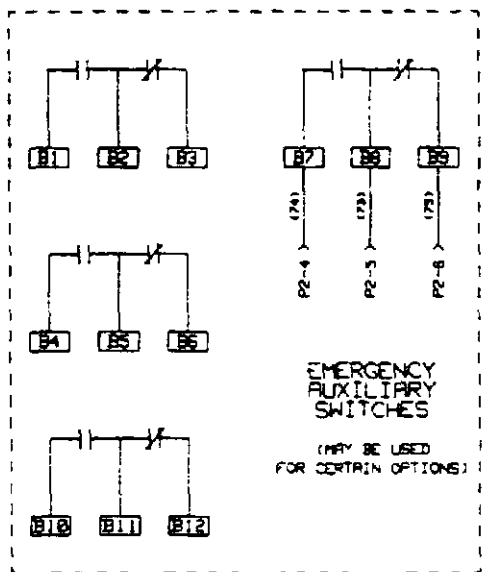
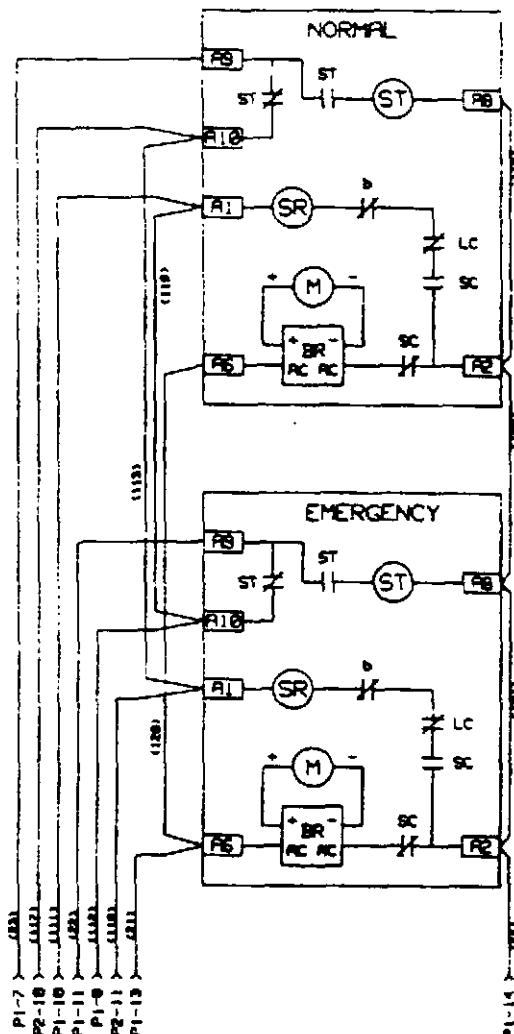
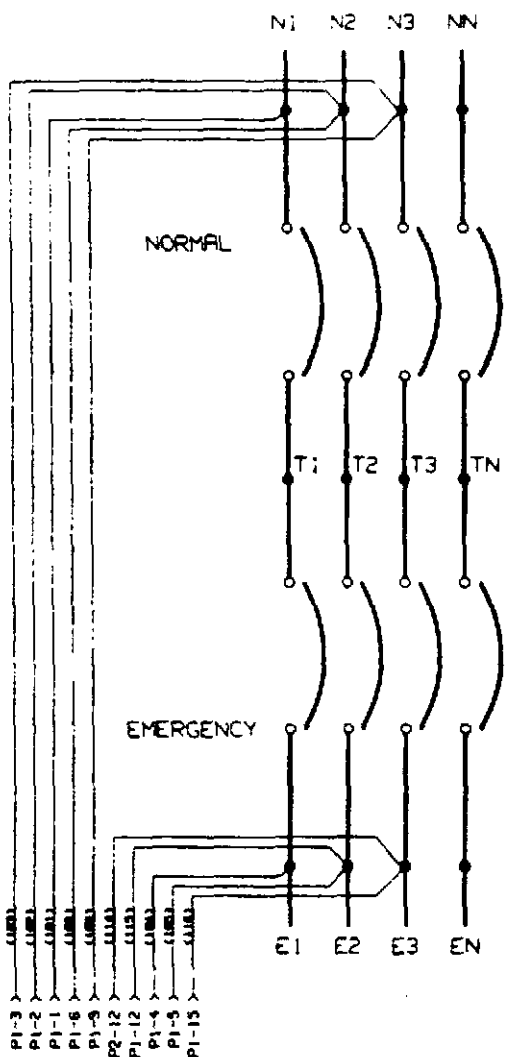

6 POSITION CARD CAGE

NORMAL		ENG	EMERGENCY		
1	2	3	4	5	6
BLANK (OPTION 26)	DRIVER	BLANK	DRIVER	BLANK (OPTION 5)	BLANK (OPTION 5)

9 POSITION CARD CAGE

NORMAL			ENG	EMERGENCY				
1	2	3	4	5	6	7	8	9
BLANK (OPTION 26)	BLANK (OPTION 26)	BLANK (OPTION 26)	DRIVER	BLANK	DRIVER	BLANK (OPTION 5)	BLANK (OPTION 5)	BLANK (OPTION 5)

OPTION 5 - EMERGENCY SENSING (LV,OV,UF,OF)

6 POSITION CARD CAGE

REPLACE BLANK CARD IN POSITION 5 OR 6  
WITH APPROPRIATE SENSING CARD

9 POSITION CARD CAGE

REPLACE BLANK CARD IN POSITION 7,8 OR 9  
WITH APPROPRIATE SENSING CARD

OPTION 26 - NORMAL SENSING (OV,UF,OF)

6 POSITION CARD CAGE

NOT AVAILABLE

9 POSITION CARD CAGE

REPLACE BLANK CARD IN POSITION 2 OR 3  
WITH APPROPRIATE SENSING CARD

\* UNDERVOLTAGE SENSING ON NORMAL IS STANDARD

- OPTION 12C - NORMAL POSITION LIGHT (NL)  
INDICATES LOAD IS CONNECTED TO NORMAL

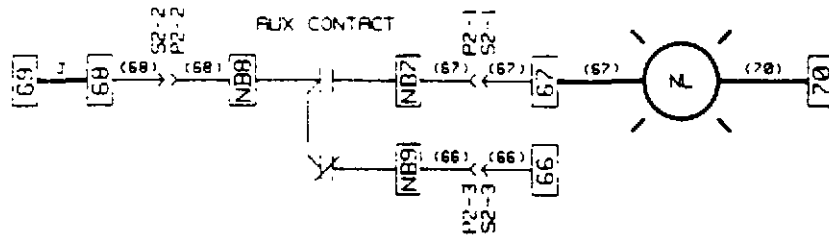

- OPTION 12D - EMERGENCY POSITION LIGHT (EL)  
INDICATES LOAD IS CONNECTED TO EMERGENCY

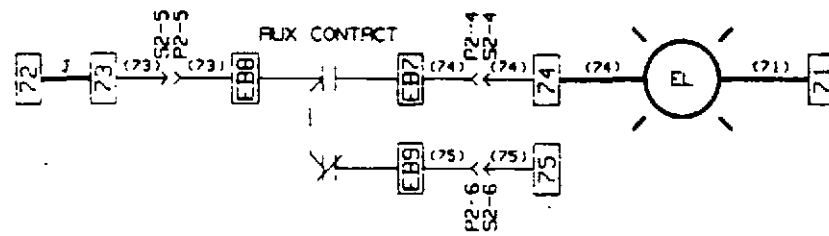

- OPTION 12G - NORMAL SOURCE LIGHT (SN)  
INDICATES NORMAL SOURCE AVAILABLE

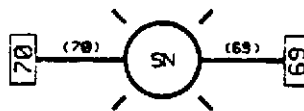

- OPTION 12H - EMERGENCY SOURCE LIGHT (SE)  
INDICATES EMERGENCY SOURCE AVAILABLE

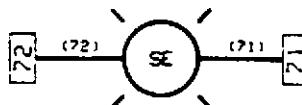

- OPTION 14C - NORMAL AUXILIARY RELAY (NRA)  
PROVIDES ADDITIONAL RELAY CONTACTS ON NORMAL

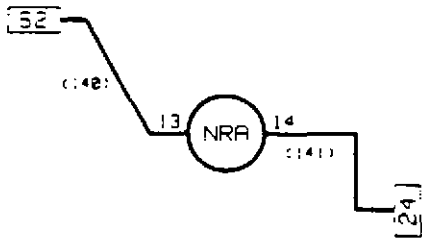

NOTE: CUSTOMER CONTACTS ARE ON RELAY SOCKET  
SEE SOCKET DIAGRAM BELOW

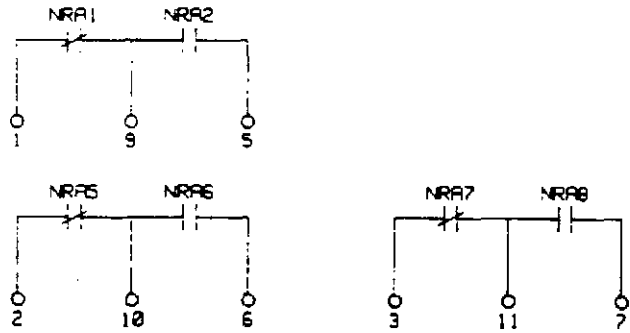

- OPTION 14D - EMERGENCY AUXILIARY RELAY (ERA)  
PROVIDES ADDITIONAL RELAY CONTACTS ON EMERGENCY



NOTE: CUSTOMER CONTACTS ARE ON RELAY SOCKET  
SEE SOCKET DIAGRAM BELOW

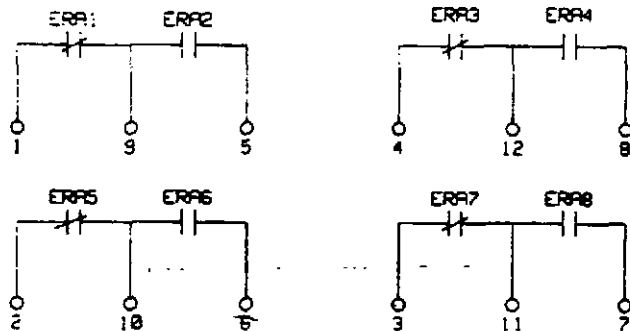

NRA - ERA SOCKET DIAGRAM

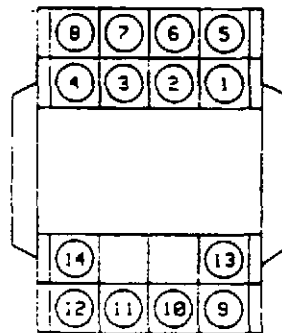

OPTION 18E - VOLTMETER

		HANDLE POSITION					
		NORMAL			EMERGENCY		
		1-3	2-3	1-2	1-2	2-3	1-3
1	2				X	X	X
3	4	X	X				
5	6				X		
7	8		X				
9	10					X	X
11	12	X					
13	14				X	X	
15	16	X	X				

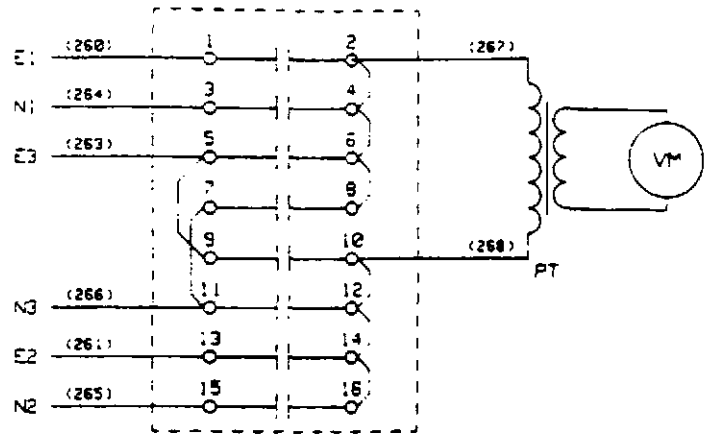

OPTION 18F - AMMETER

		HANDLE POSITION					
		OFF	1	2	3		
1	2	X	X	X	X	X	X
3	4	X	X	X	X	X	X
5	6	X	X	X	X	X	X
7	8	X	X	X	X	X	X
9	10	X	X	X	X	X	X
11	12	X	X	X	X	X	X

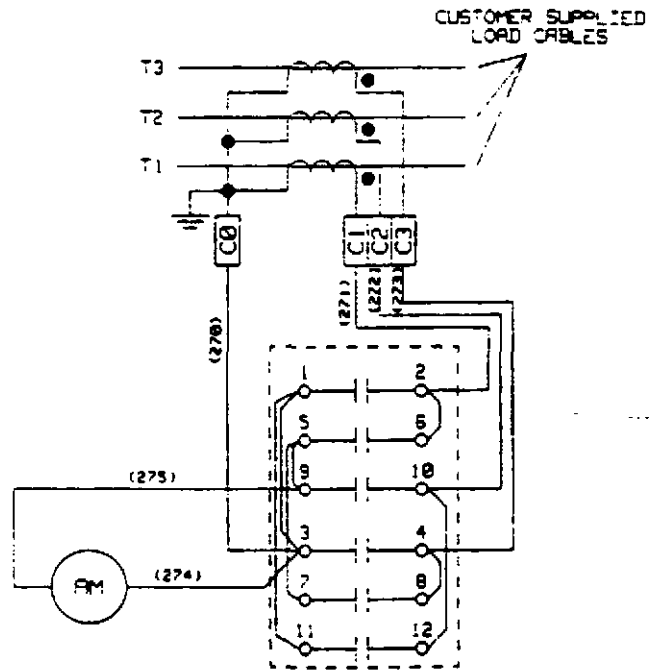

OPTION 18G - FREQUENCY METER

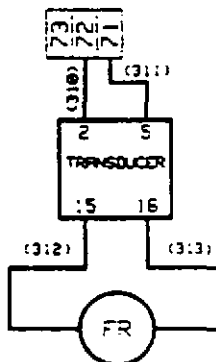

OPTION 18H - RUNNING TIME METER

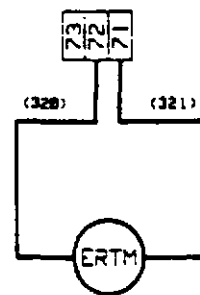

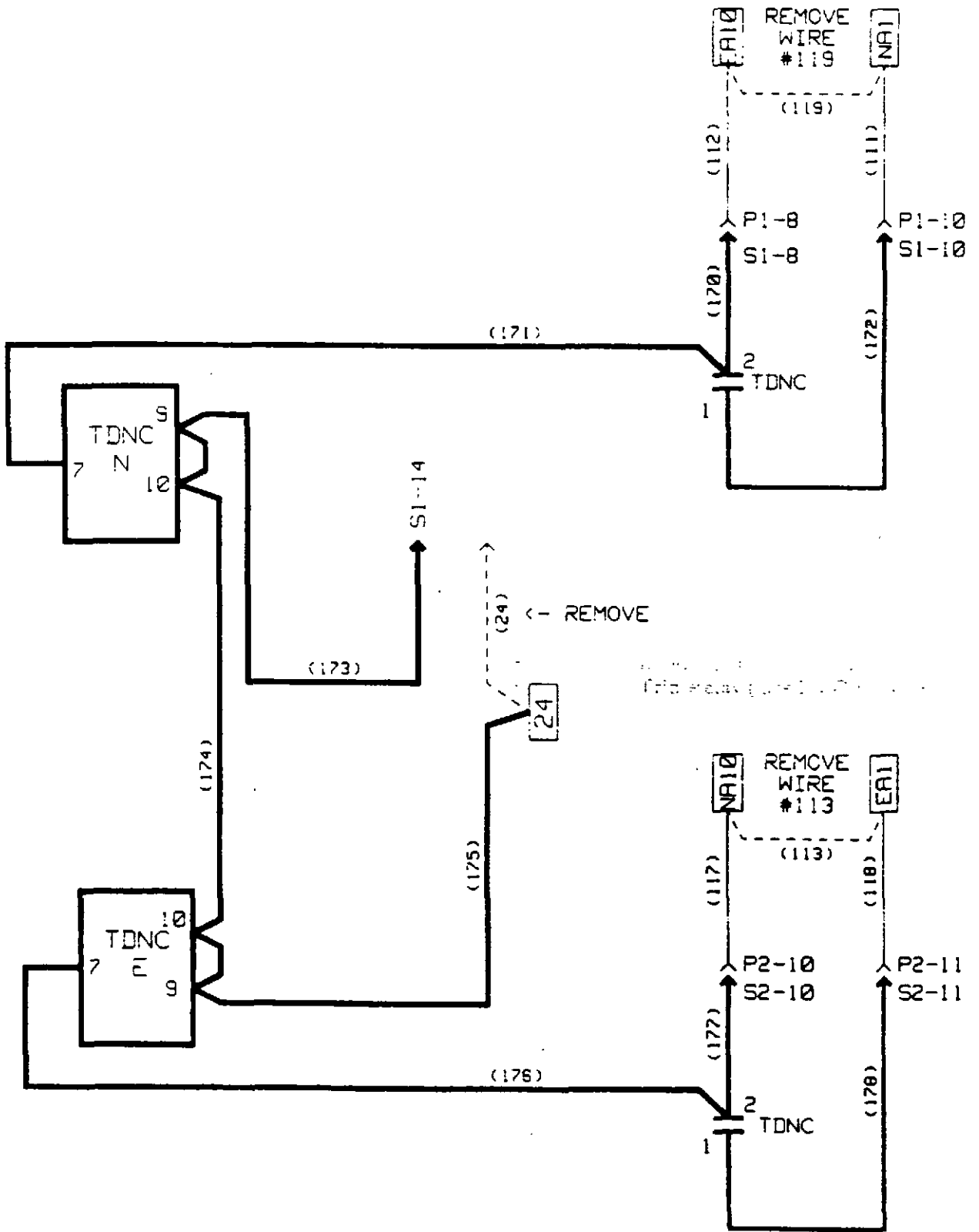

# Westinghouse SPB Non-Automatic Transfer Switch Legends for Wiring Diagram Symbols

Page 8

Sym	Description
AM	Ammeter
Ex	Power Terminal, Emergency Source (x = Terminal Number)
EASx	Emergency Lockout (x = contact number)
EC	Engine Cooloff Relay Coil
ECx	Engine Cooloff Relay Contact (x = Contact Number)
EL	Emergency Position Indicator Light
EMPB	Emergency Pushbutton for MAnual Operation
EMR	Emergency Relay (for Manual Operation)
ER	Emergency Relay Coil
ERx	Emergency Relay Contact (x = Contact Number)
ERA	Emergency Auxiliary Relay
ERAx	Emergency Auxiliary Relay Contact (x = Contact Number)
ERTM	Generator Run Time Meter
ESx	Emergency Auxiliary Switch (x = Contact Number)
ET1	Emergency Transformer (Line Voltage to 120VAC - 2 windings)
ET2	Emergency Transformer (Line Voltage to 24VAC CT)
ET3	Emergency Transformer (Line Voltage to 12VAC)
ET4	Emergency Transformer (Line Voltage to 12VAC)
FPSS	Four Position Selector Switch (Option 6H)
FR	Frequency Meter
Fx	Fuse (x = fuse number)
KF	Failsafe Relay
KS	Load Shed Relay
KT	Trip Relay (Used w/Option 16)
KV	Voting Relay
MSS	Maintenance Selector Switch
NASx	Normal Lockout (x = contact number)
Nx	Power Terminal, Normal (x = Terminal Number)
NL	Normal Position Indicator Light
NMPB	Normal Pushbutton for Manual Operation
NR	Normal Relay Coil
NRx	Normal Relay Contact (x = contact number)
NRA	Normal Auxiliary Relay Coil
NRAx	Normal Auxiliary Relay Contact (x = Contact Number)
NSx	Normal Auxiliary Switch (x = Contact Number)
NT1	Normal Transformal (Line Voltage to 120VAC - 2 windings)
NT2	Normal Transformer (Line Voltage to 24VAC CT)
NT3	Normal Transformer (Line Voltage to 12VAC)
NT4	Normal Transformer (Line Voltage to 12VAC)
Px-y	Plug (x = plug number, y = terminal number)
PBEN	Bypass TDEN Pusgbutton
PBNE	Bypass TDNE Pushbutton
PBRE	Reset Emergency Breaker Pushbutton
PBRN	Reset Normal Breaker Pushbutton
PE	Plant Exerciser

# Westinghouse SPB Non-Automatic Transfer Switch Legends for Wiring Diagram Symbols Page 9

<b>Sym</b>	<b>Description</b>
PSDR	Pre-Transfer Signal Device Relay
PSDT	Pre-Transfer Signal Device Timer
PSS	Preferred Source Selector Switch
Sx-y	Socket (x = socket number, y = terminal number)
SDL	Service Disconnect Light
SDSS	Service Disconnect Selector Switch
SD	Services Disconnected Light
SE	Emergency Source Available Indicator Light
SN	Normal Source Available Indicator Light
Tx	Power Terminal, Load (x = Terminal Number)
TPB	Test Pushbutton
VM	Voltmeter

---

# MANUAL TRANSFER SWITCH WIRING DIAGRAMS

CATALOG NUMBER **MTSBM** ONLY

SOLID STATE TYPE SWITCH

SHOP ORDER: \_\_\_\_\_

WESTINGHOUSE ELECTRIC CORPORATION  
250 WESTINGHOUSE DRIVE  
LONDON, KY 40741

---

# SWITCHING PANEL ATSBM, MTSBM, OR ATSBP

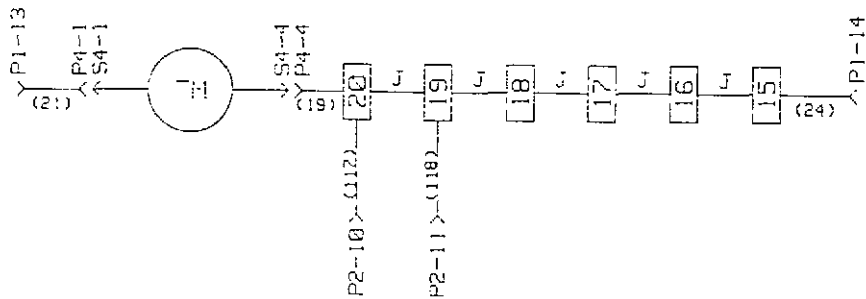
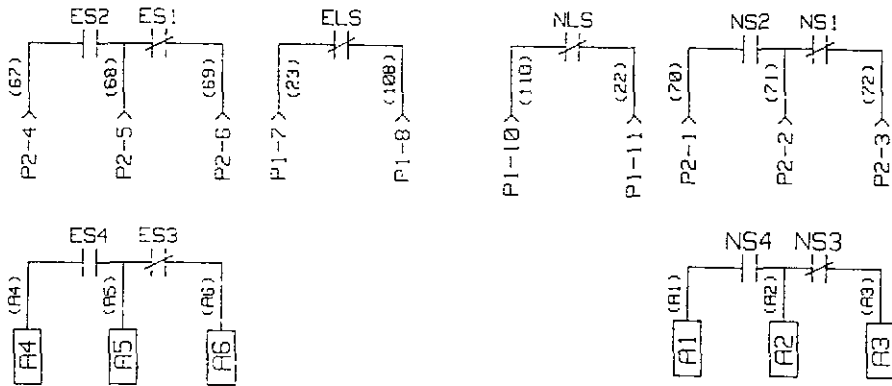
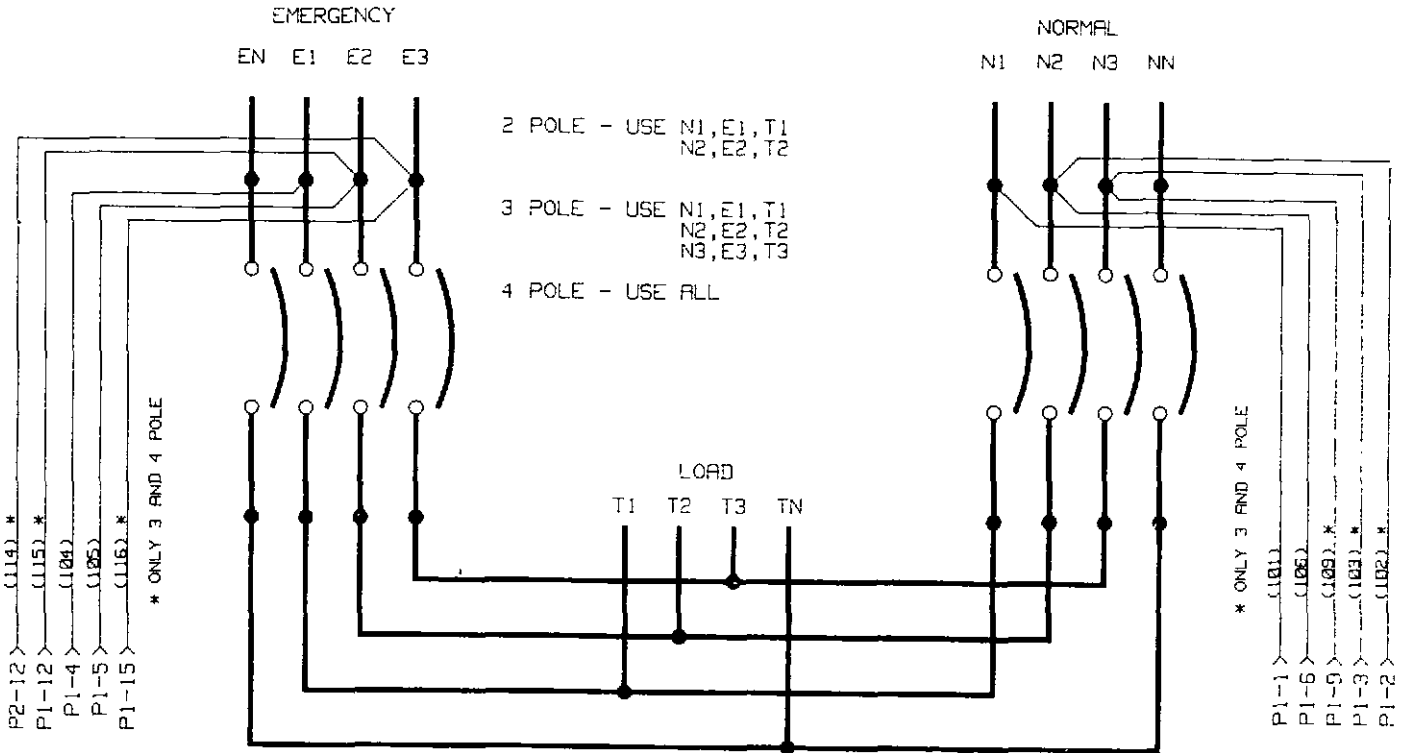

# SWITCHING PANEL

SERIES C ONLY (150 AMP OR HIGHER)

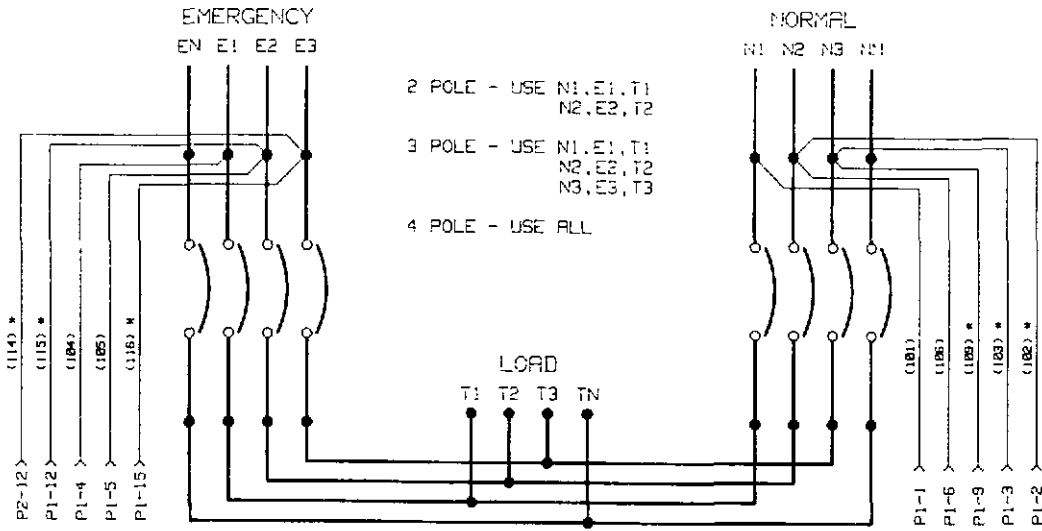

\* ONLY 3 AND 4 POLE UNITS

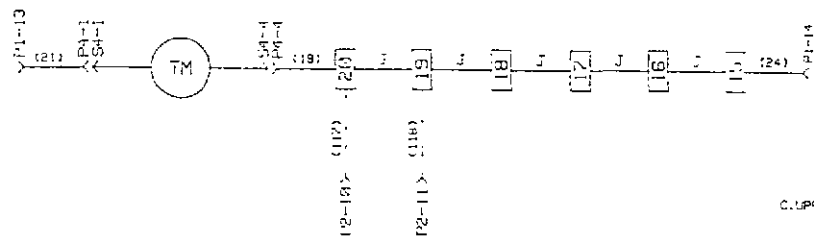
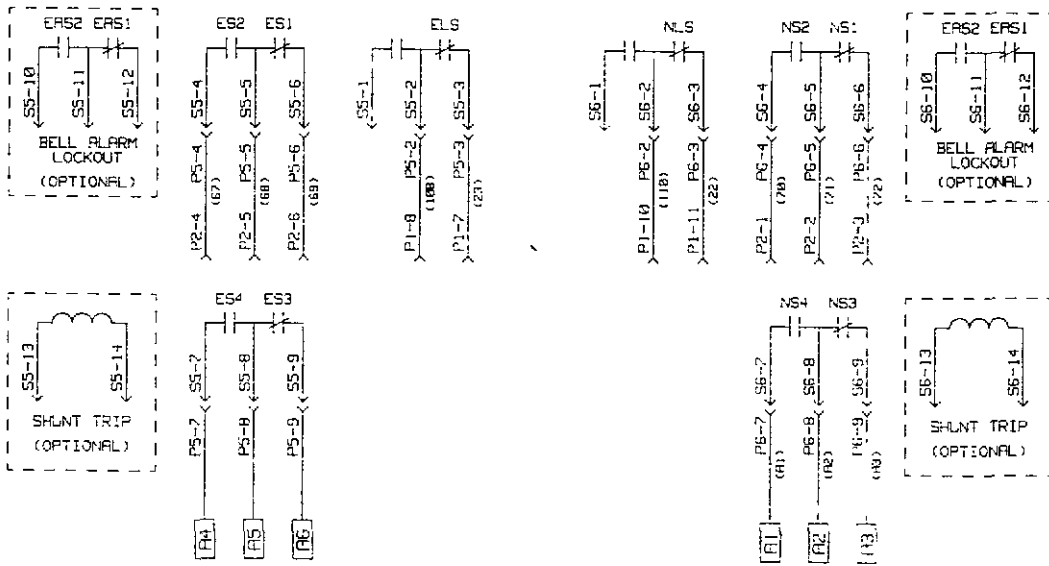

# SOLID STATE INTELLIGENCE PANEL

NOTE A

NOTE A:  
 TRANSFORMERS NT3, NT4 AND WIRES 183, 189 USED FOR 3 PHASE NORMAL SENSING  
 TRANSFORMERS ET3, ET4 AND WIRES 114, 116 USED FOR 3 PHASE EMERGENCY SENSING

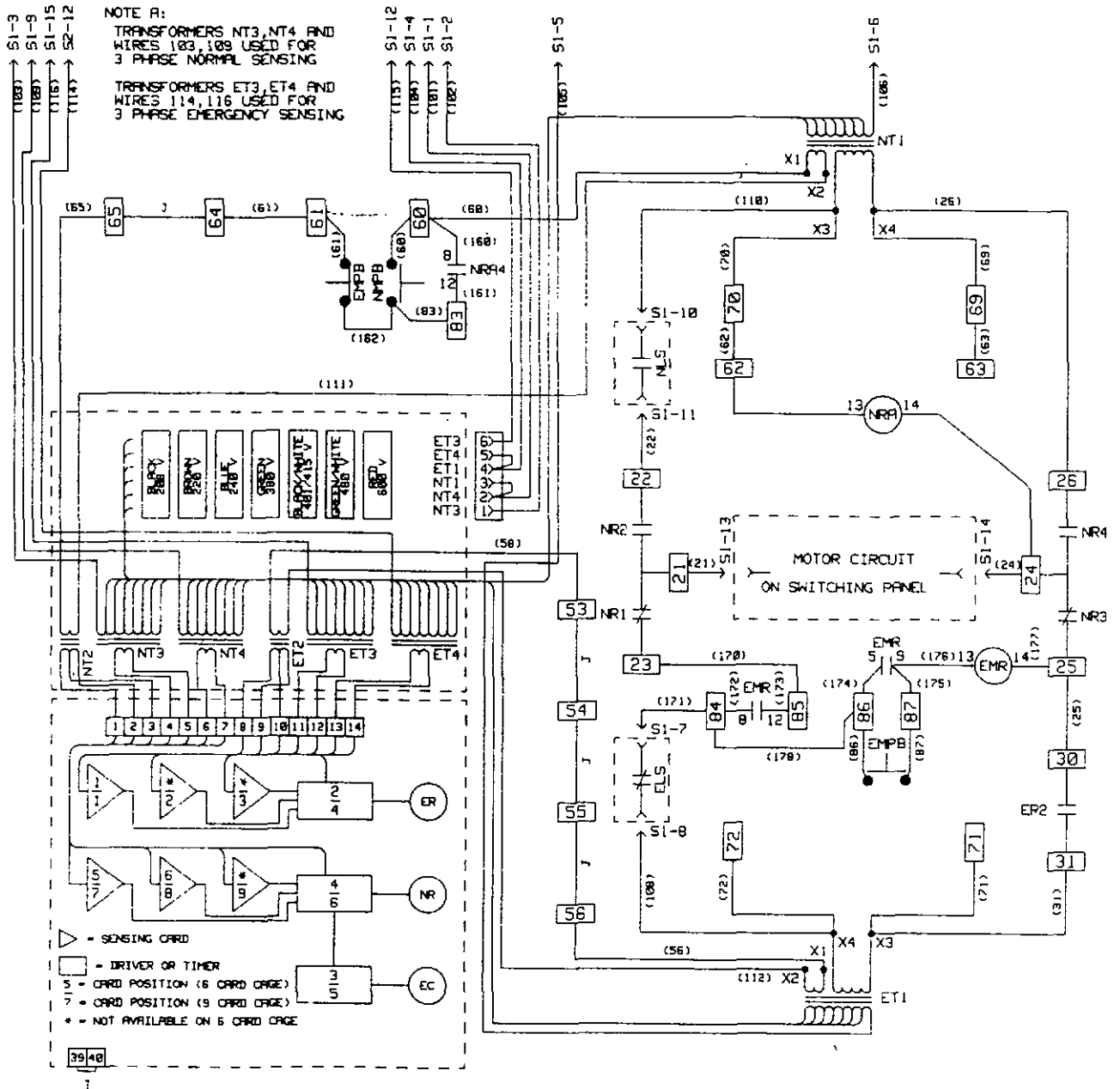

- ▽ = SENSING CARD
- = DRIVER OR TIMER
- 5 = CARD POSITION (6 CARD CAGE)
- 7 = CARD POSITION (9 CARD CAGE)
- \* = NOT AVAILABLE ON 6 CARD CAGE

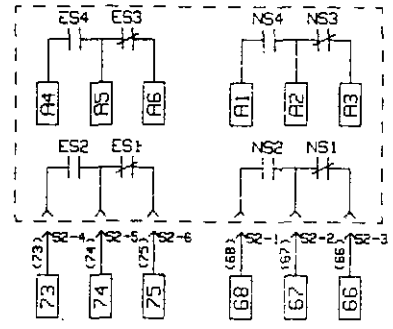
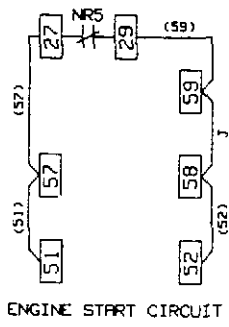

6 POSITION CARD CAGE

NORMAL		ENG	EMERGENCY		
1	2	3	4	5	6
BLANK (OPTION 26)	DRIVER	BLANK	DRIVER	BLANK (OPTION 5)	BLANK (OPTION 5)

9 POSITION CARD CAGE

NORMAL			ENG	EMERGENCY				
1	2	3	4	5	6	7	8	9
BLANK (OPTION 26)	BLANK (OPTION 26)	BLANK (OPTION 26)	DRIVER	BLANK	DRIVER	BLANK (OPTION 5)	BLANK (OPTION 5)	BLANK (OPTION 5)



OPTION 5 - EMERGENCY SENSING

6 POSITION CARD CAGE

REPLACE BLANK CARD IN POSITION 5 OR 6  
WITH APPROPRIATE SENSING CARD

9 POSITION CARD CAGE

REPLACE BLANK CARD IN POSITION 7, 8 OR 9  
WITH APPROPRIATE SENSING CARD



OPTION 26 - NORMAL SENSING

6 POSITION CARD CAGE

REPLACE BLANK CARD IN POSITION 1  
WITH APPROPRIATE SENSING CARD

9 POSITION CARD CAGE

REPLACE BLANK CARD IN POSITION 2 OR 3  
WITH APPROPRIATE SENSING CARD

- OPTION 12A/C - NORMAL POSITION LIGHT  
INDICATES LOAD IS CONNECTED TO NORMAL

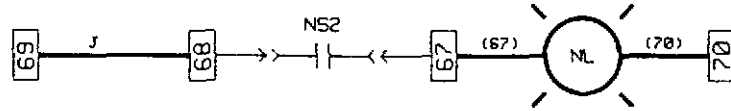

- OPTION 12B/D - EMERGENCY POSITION LIGHT  
INDICATES LOAD IS CONNECTED TO EMERGENCY

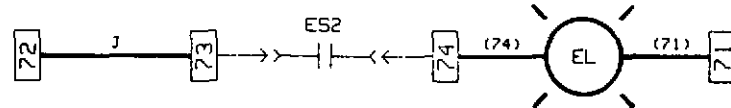

- OPTION 12E/G - NORMAL SOURCE LIGHT  
INDICATES NORMAL SOURCE AVAILABLE

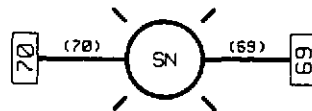

- OPTION 12F/H - EMERGENCY SOURCE LIGHT  
INDICATES EMERGENCY SOURCE AVAILABLE

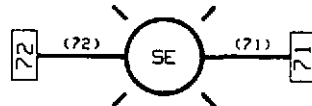

- OPTION 12J/L - NORMAL TRIPPED INDICATOR  
INDICATES OVERLOAD TRIP ON NORMAL

NOTE: ONLY AVAILABLE WHEN  
OPTION 11F IS SUPPLIED

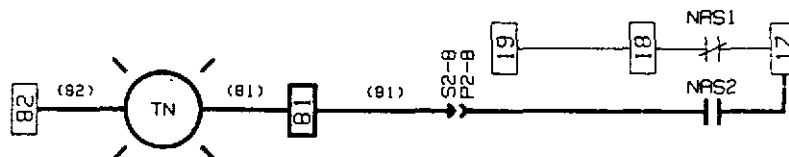

- OPTION 12K/M - EMERGENCY TRIPPED INDICATOR  
INDICATES OVERLOAD TRIP ON EMERGENCY

NOTE: ONLY AVAILABLE WHEN  
OPTION 11F IS SUPPLIED

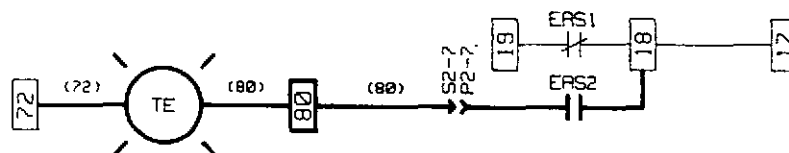



OPTION 14C - NORMAL AUXILIARY RELAY (NRA)  
 PROVIDES ADDITIONAL RELAY CONTACTS ON NORMAL

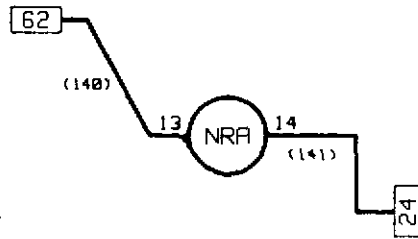

NOTE: CUSTOMER CONTACTS ARE ON RELAY SOCKET  
 SEE SOCKET DIAGRAM BELOW

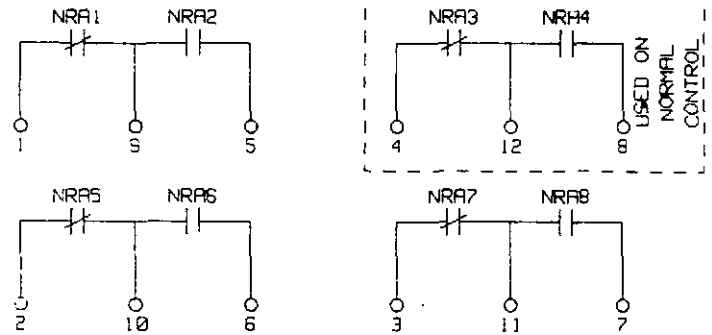

OPTION 14D - EMERGENCY AUXILIARY RELAY (ERA)  
 PROVIDES ADDITIONAL RELAY CONTACTS ON EMERGENCY



NOTE: CUSTOMER CONTACTS ARE ON RELAY SOCKET  
 SEE SOCKET DIAGRAM BELOW

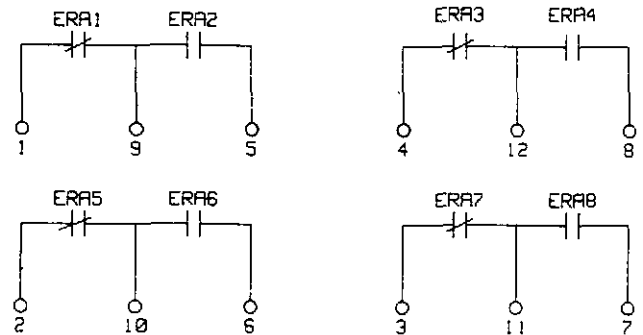

NRA - ERA SOCKET DIAGRAM

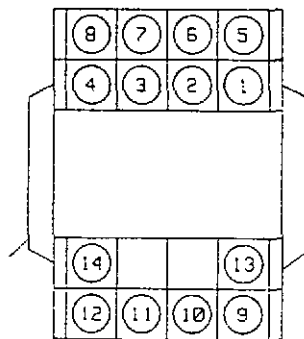

OPTION 18E - VOLTMETER

	HANDLE POSITION					
	NORMAL			EMERGENCY		
	1-3	2-3	1-2	1-2	2-3	1-3
1 — 2				X		X
3 — 4	X		X			
5 — 6					X	
7 — 8		X				
9 — 10						X
11 — 12	X					
13 — 14				X	X	
15 — 16		X	X			

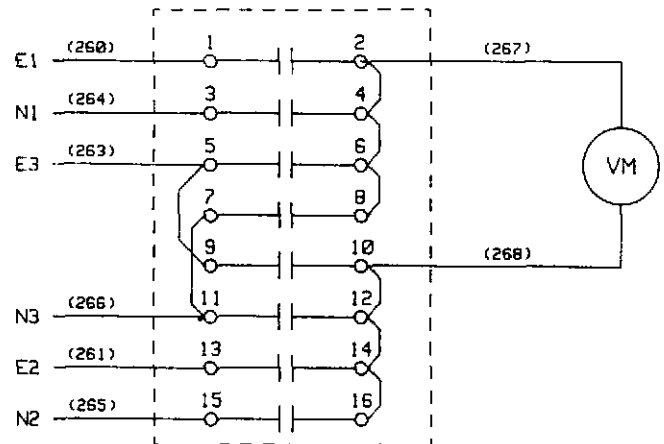

OPTION 18F - AMMETER

	HANDLE POSITION							
	OFF	-	1	-	2	-	3	-
1 — 2	X	X	X	X	X	X	X	X
3 — 4	X	X	X	X	X	X	X	X
5 — 6	X	X	X	X	X	X	X	X
7 — 8	X	X	X	X	X	X	X	X
9 — 10	X	X	X	X	X	X	X	X
11 — 12	X	X	X	X	X	X	X	X

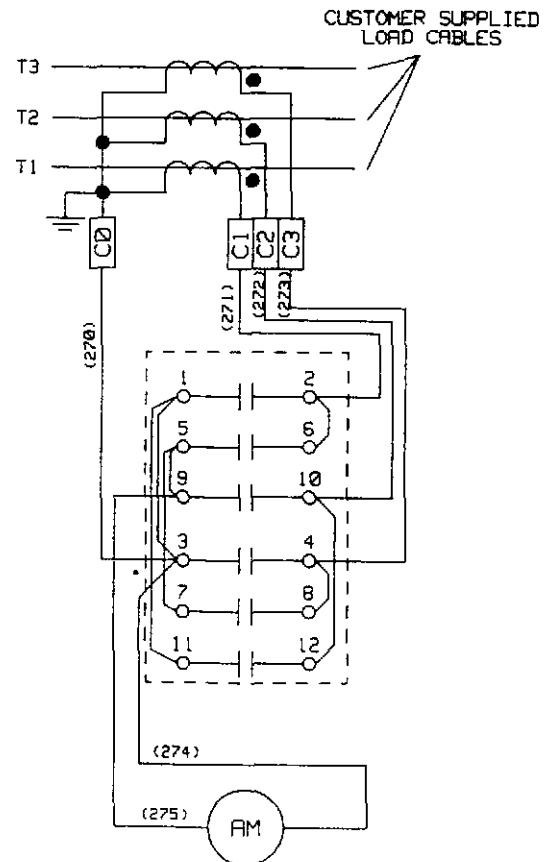

OPTION 18G - FREQUENCY METER

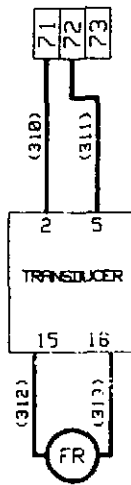

OPTION 18H - RUNNING TIME METER

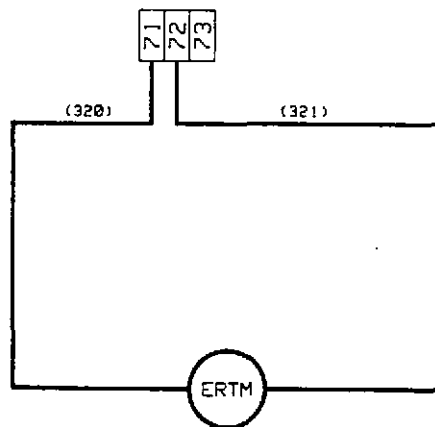

- OPTION 32 - TIME DELAY NEUTRAL (TDN)**  
 PROVIDES A TIME DELAY IN THE NEUTRAL POSITION WHEN THE LOAD IS TRANSFERRED IN EITHER DIRECTION TO PREVENT EXCESSIVE INRUSH CURRENTS DUE TO OUT-OF-PHASE SWITCHING OF INDUCTIVE LOADS

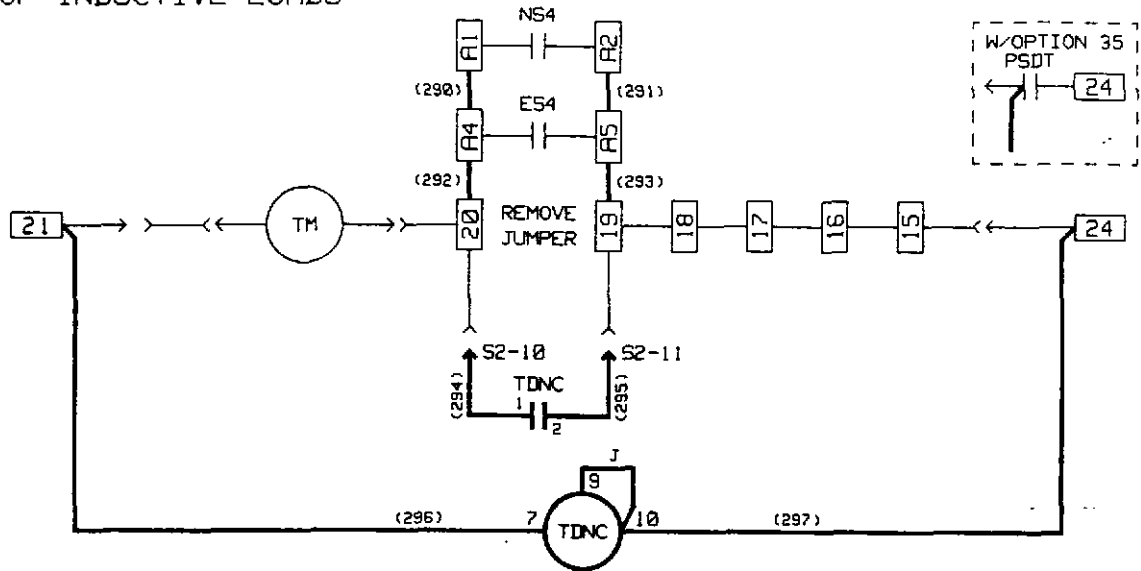

- OPTION 35 - PRETRANSFER SIGNAL DEVICE**  
 RELAY CONTACTS CHANGE STATE PRIOR TO TRANSFER WITH PRESET TIME DELAY

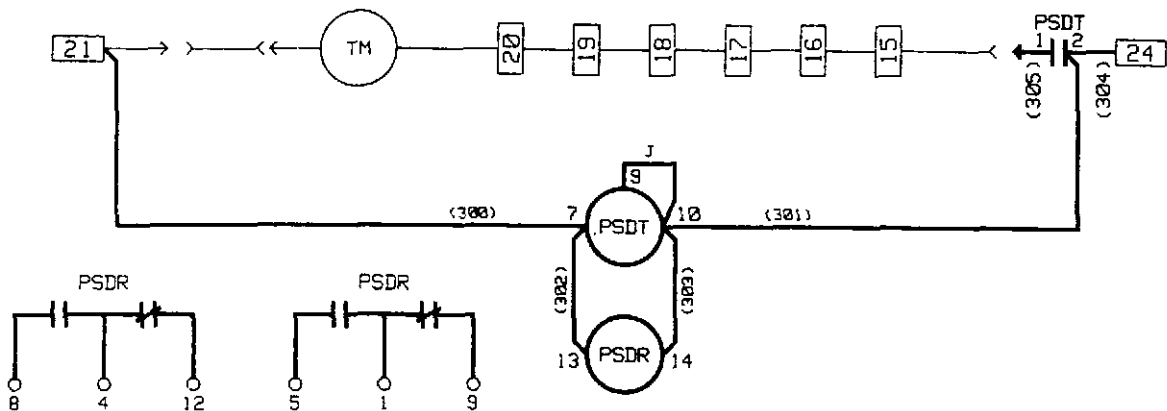

CUSTOMER CONTACTS ARE ON RELAY SOCKET

# MTSBM ONLY

OPTION 37 - SERVICE EQUIPMENT

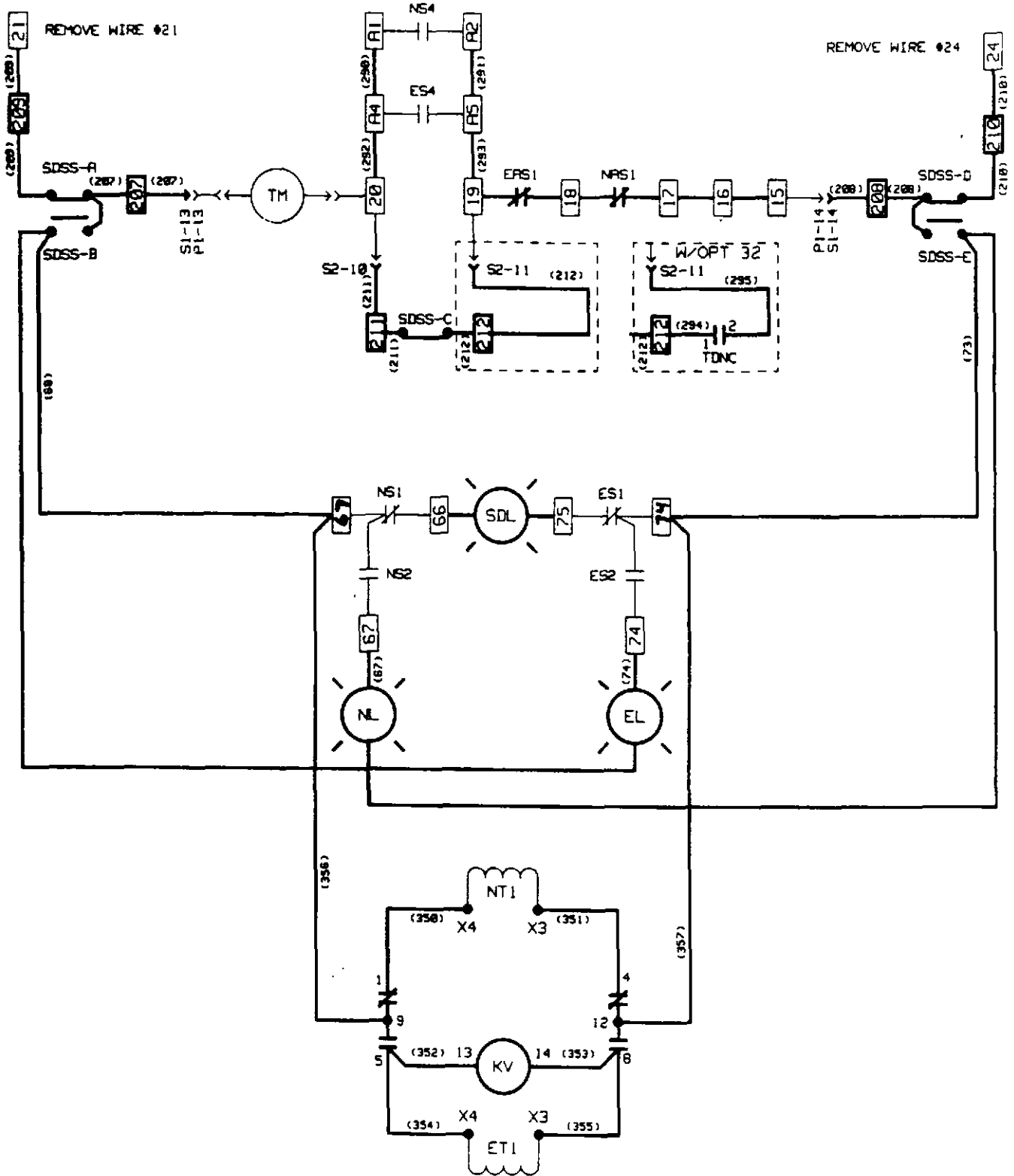

SDSS	A	B	C	D	E
DISCONNECT		X	X	X	X
ENERGIZE	X		X	X	X

KEY REMOVABLE IN "DISCONNECT" POSITION

# ATSBR TRANSFER SWITCH

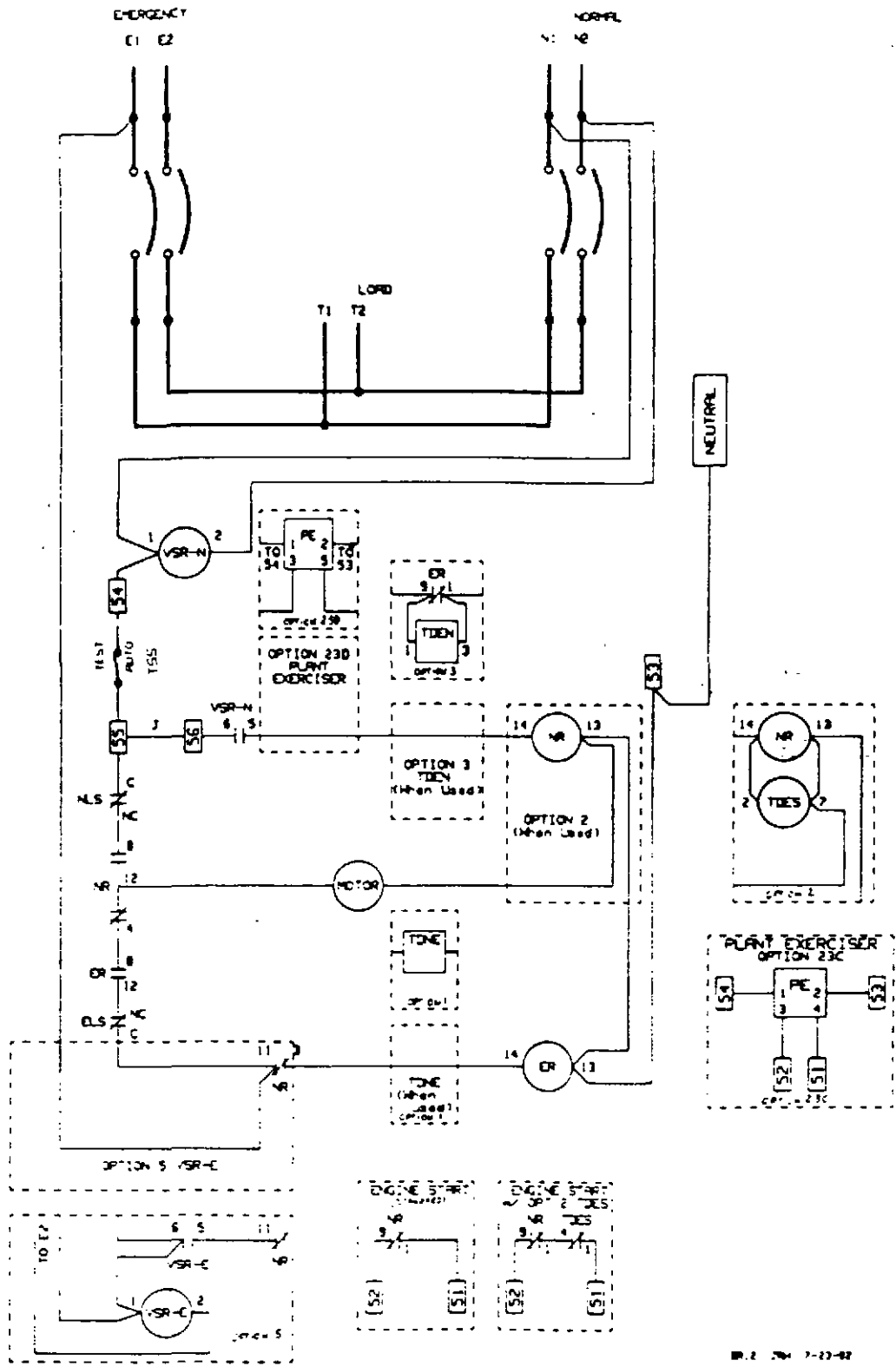

Typical Wiring Diagram

# **Cutler-Hammer Beaver, PA**

Automatic Transfer Switch

## Type ATVS/ATHSFD Wiring Diagrams

Version 3.0 Aug 2, 1995



**Cutler-Hammer**

---

**EATON**

Copyright 1995 by Eaton/Cutler Hammer Inc.  
All rights reserved

Page No

Date

VUPPER.DWG	10 Feb 95
UPPR100.DWG	2 Aug 95
VSSXFMR.DWG	8 May 95
VSSINTL.DWG	29 Jun 95
VSS01.DWG	29 Jun 95
VSS02.DWG	25 Jul 95
VSS03.DWG	8 May 95
VSS04.DWG	2 Aug 95
VSS05.DWG	25 Jul 95
VSS05A.DWG	1 Aug 95
VSS06.DWG	27 Jun 95
VSS07.DWG	27 Jul 95
VSS08.DWG	27 Jul 95
VSS09.DWG	8 May 95
VSS10.DWG	12 Jun 95
VSS11.DWG	1 Aug 95
VSS12.DWG	1 Aug 95
VSS13.DWG	16 Feb 95

Plug - Pin assignments for the SOLID STATE LOGIC Transfer Switch

P1 - Switching Panel

S1 - Transformer Panel

1	Normal	N1	Phase A
2	Normal	N2	Phase B
3	Normal	N3	Phase C
4	Normal	N1	Phase A
5	Normal	N2	Phase B
6	Normal	N3	Phase C
7	N Aux Sw #1	N.O.	
8	N Aux Sw #1	C	
9	N Aux Sw #1	N.C.	
10	N Aux Sw #2	N.O.	
11	N Aux Sw #2	C	
12	N Aux Sw #2	N.C.	
13	N Aux Sw #3	N.O.	
14	N Aux Sw #3	C	
15	N Aux Sw #3	N.C.	

P2 - Switching Panel

S2 - Transformer Panel

1	Emergency	E3	Phase C
2	Emergency	E2	Phase B
3	Emergency	E1	Phase A
4	Emergency	E3	Phase C
5	Emergency	E2	Phase B
6	Emergency	E1	Phase A
7	E Aux Sw #1	N.O.	
8	E Aux Sw #1	C	
9	E Aux Sw #1	N.C.	
10	E Aux Sw #2	N.O.	
11	E Aux Sw #2	C	
12	E Aux Sw #2	N.C.	
13	E Aux Sw #3	N.O.	
14	E Aux Sw #3	C	
15	E Aux Sw #3	N.C.	

P3 - Switching Panel to  
S3 - Transformer Panel

1		
2		
3		
4	Motor	Bridge "AC" In
5	Motor	Bridge "AC" In
6		
7	Lockout (Normal)	N.C.
8		Com
9		N.O.
10	Lockout (Emergency)	N.C.
11		Com
12		N.O.

P4 - Transformer Panel to  
S4 - Intelligence Panel

1	Motherboard 1
2	Motherboard 2
3	Motherboard 3
4	Motherboard 4
5	Motherboard 5
6	Motherboard 6
7	Motherboard 7
8	Motherboard 8
9	Motherboard 9
10	Motherboard 10
11	Motherboard 11
12	Motherboard 12
13	Motherboard 13
14	Motherboard 14
15	

S5 - Transformer Panel to  
P5 - Intelligence Panel (Door)

1	Normal Operate
2	Emergency Operate
3	Control Neutral
4	Normal Control Power
5	Emergency Control Power
6	Normal Position Light
7	Emergency Position Light
8	Normal Logic Interrupt - Test Pushbutton
9	Normal Logic Interrupt - Test Pushbutton
10	Emergency Logic Interrupt

- 11 Emergency Logic Interrupt
- 12 Motor Circuit
- 13 NR Relay Output
- 14 Engine Start Circuit Source 2
- 15 Engine Start Circuit Source 2

S6 - Transformer Panel to  
P6 - Intelligence Panel (Door)

- 1 Service Disconnect Motor Interrupt
- 2 Service Disconnect Motor Interrupt
- 3 Disconnect Indicator
- 4 Voting Relay Output
- 5 Normal Trip Light Contact
- 6 Emergency Trip Light Contact

S7a - g Voltage Selector - Socket  
P7 - Plug

- 1 NT3
- 2 NT4
- 3 NT1
- 4 ET1
- 5 ET4
- 6 ET3

# Cutler-Hammer Automatic Transfer Switch Wiring Diagrams

## Directions for Use

The drawing package can be used as a point to point wiring diagram for maintenance and diagnostic purposes for Solid State Logic Transfer Switches, 150 - 1000 Ampere, all voltages.

This document contains the following wiring information:

- Basic Switching Panel Wiring
- Basic wiring diagrams for the transformer and intelligence panels.
- Wiring for all normally available features. (Options)
- Legend Sheet describing symbols used throughout this document.

Note: Additional sheets may be provided with this document on occasion to illustrate custom wiring provided for a specifically supplied function which is not normally available

## Legend Sheet

<b>BR</b>	<b>Bridge Rectifier</b>
<b>EL</b>	<b>Emergency Position Indicator Light</b>
<b>ER</b>	<b>Emergency Relay</b>
<b>ERA</b>	<b>Emergency Auxiliary Relay</b>
<b>ERB</b>	<b>Emergency Auxiliary Relay</b>
<b>ETx</b>	<b>Emergency Transformer</b>
<b>Ex</b>	<b>Emergency Power Terminal x</b>
<b>FPSS</b>	<b>Four Position Selector Switch (Option 6H)</b>
<b>KB</b>	<b>Brake Relay</b>
<b>KE</b>	<b>Emergency Failsafe Relay</b>
<b>KF</b>	<b>Failsafe Relay</b>
<b>MSS</b>	<b>Maintenance Selector Switch</b>
<b>NL</b>	<b>Normal Position Indicator Light</b>
<b>NR</b>	<b>Normal Relay</b>
<b>NRA</b>	<b>Normal Auxiliary Relay</b>
<b>NRB</b>	<b>Normal Auxiliary Relay</b>
<b>NTx</b>	<b>Normal Transformer x</b>
<b>Nx</b>	<b>Normal Power Terminal x</b>
<b>PBEN</b>	<b>Pushbutton Bypass TDEN timer</b>
<b>PBNE</b>	<b>Pushbutton Bypass TDNE timer</b>
<b>PE</b>	<b>Plant Exerciser Clock</b>
<b>PSDR</b>	<b>Pretransfer Signal Relay</b>
<b>PSDT</b>	<b>Pretransfer Signal Timer</b>
<b>Px-y</b>	<b>"Plug Number x, Pin Number y"</b>
<b>SDSS</b>	<b>Service Disconnect Selector Switch</b>
<b>Sx-y</b>	<b>"Socket Number x, Pin Number y"</b>
<b>TDCL</b>	<b>Time Delay Crank Limiter</b>
<b>TDEC</b>	<b>Time Delay Engine Cooloff</b>
<b>TDEN</b>	<b>Time Delay Emergency to Normal</b>
<b>TDES</b>	<b>Time Delay Engine Start</b>
<b>TDN</b>	<b>Time Delay Neutral</b>
<b>TDNE</b>	<b>Time Delay Normal to Emergency</b>

# 100 Amp Switching Panel Assembly

Cat. No. ATHS or ATHE ONLY

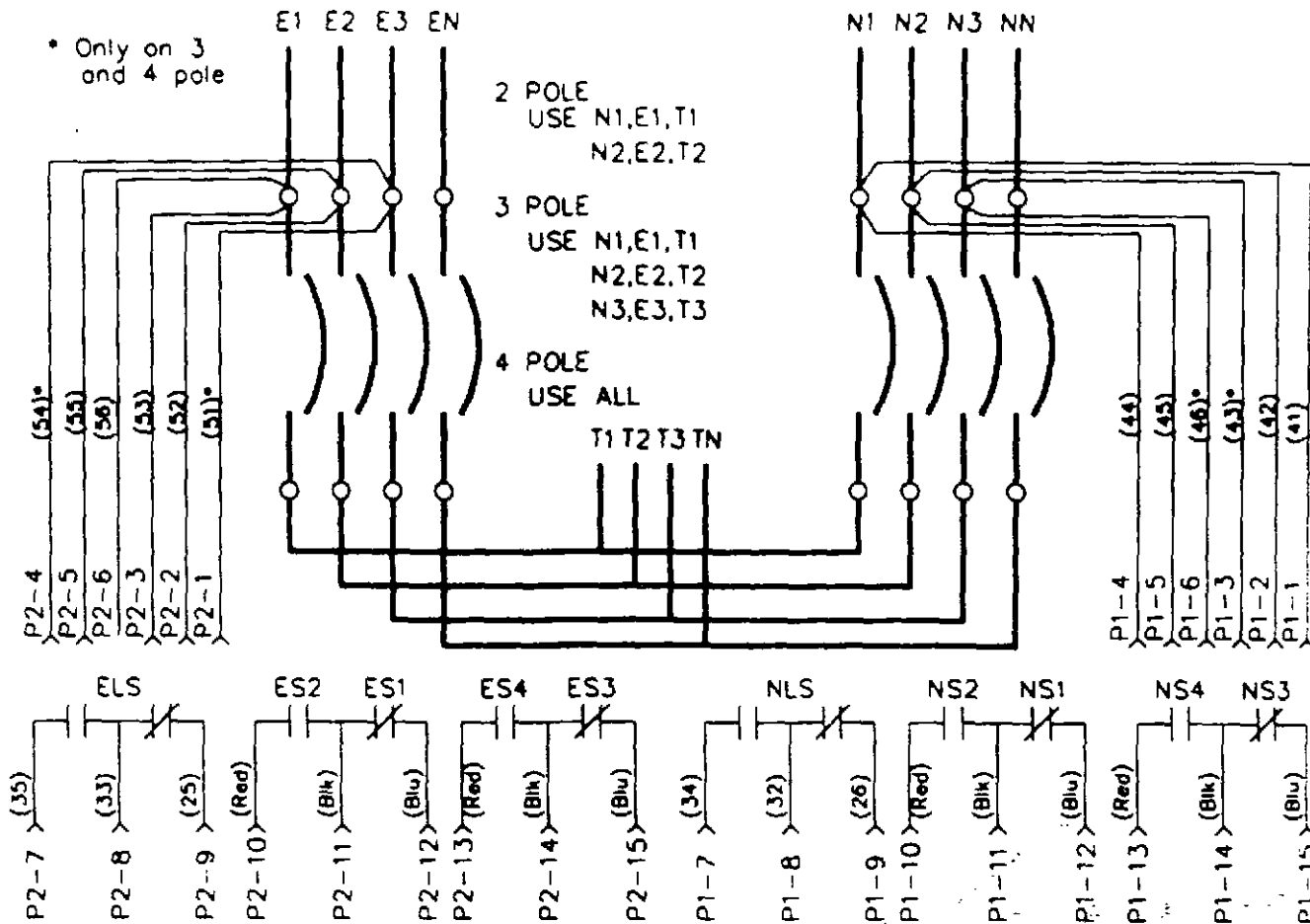

NLS and ELS are located on the mechanism

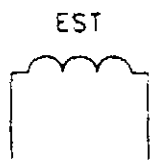

EST  
SHUNT TRIP  
(OPTIONAL)

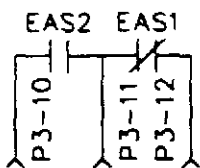

(A6) EAS2 EAS1  
BELL ALARM  
LOCKOUT  
(OPTIONAL)

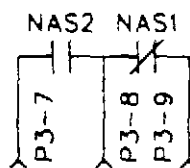

NAS2 NAS1  
BELL ALARM  
LOCKOUT  
(OPTIONAL)

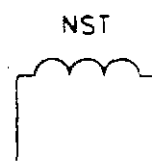

NST  
SHUNT TRIP  
(OPTIONAL)

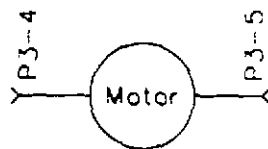

# Switching Panel (150 - 1000 Ampere, 2,3,or 4 pole)

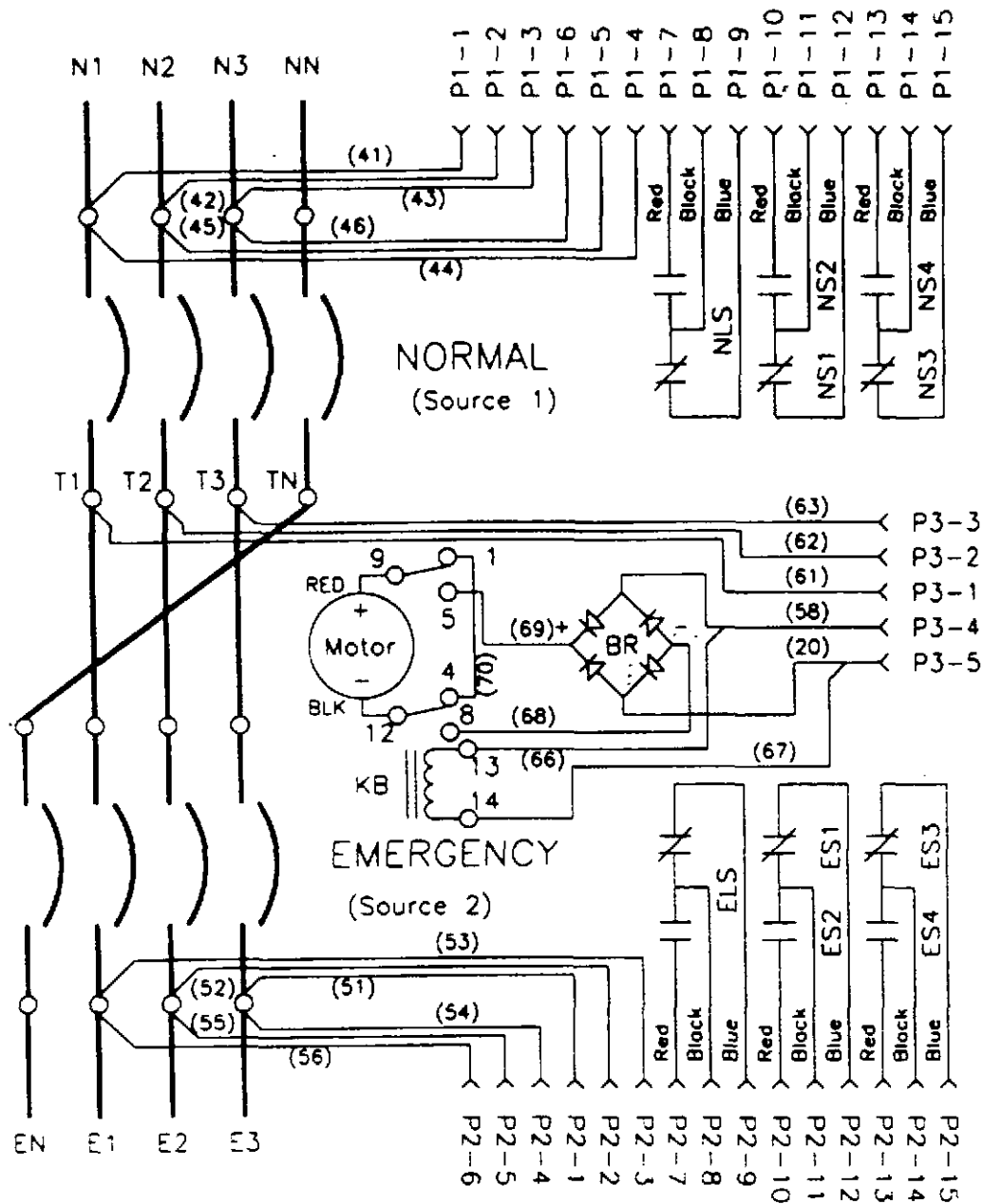



# Intelligence Panel

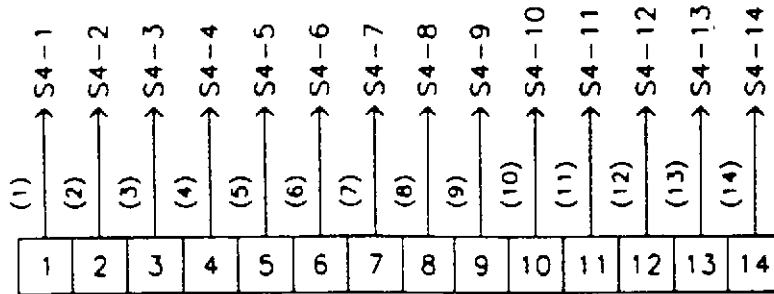

P5-3 > Control Neutral

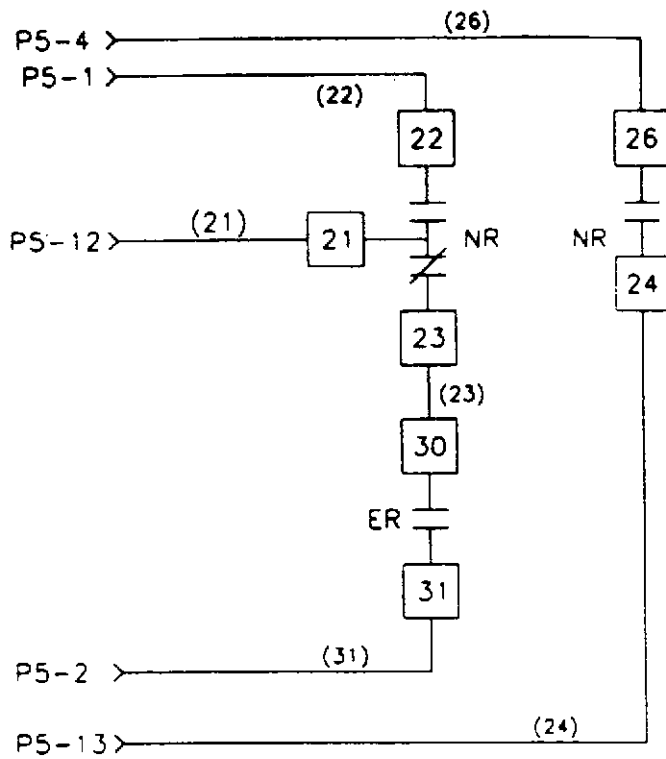

P5-5 >

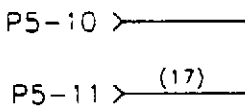
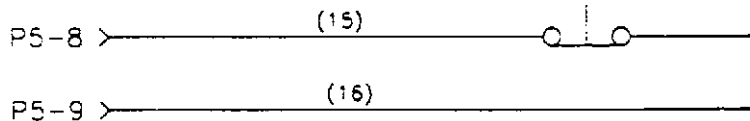
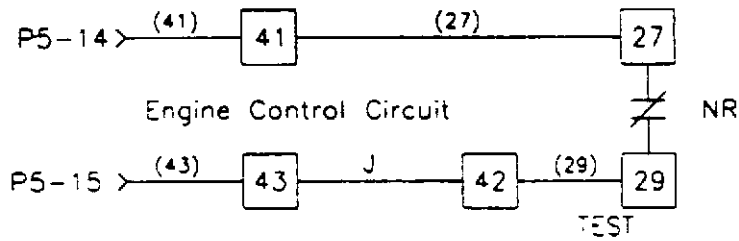

6 Position Card Cage

9 Position Card Cage

Undervoltage Standard
Driver (Option 3)
Blank (Option 4)
Driver (Option 1)
Blank (Option 5)
Blank (Option 5)

Undervoltage Standard
Blank (Option 26)
Blank (Option 26)
Driver (Option 3)
Blank (Option 4)
Driver (Option 1)
Blank (Option 5)
Blank (Option 5)
Blank (Option 5)

Option 1 Time Delay Normal to Emergency (TDNE)

6 Position Card Cage  
Replace Driver Card in Position 2  
with Timer Card

9 Position Card Cage  
Replace Driver Card in Position 4  
with Timer Card

Option 2 Time Delay Engine Start (TDES)

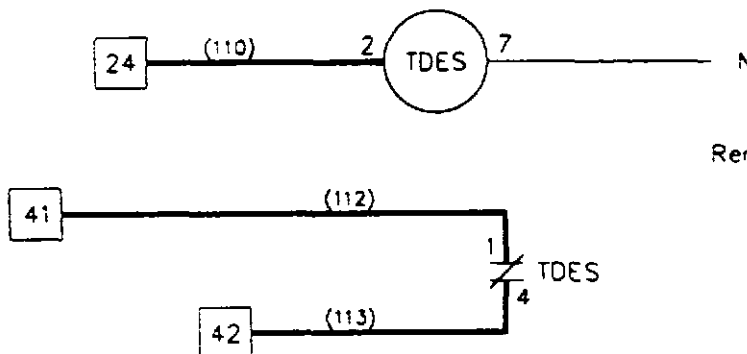

Remove wires: #27 (Term 41 to Term 27)  
and #29 (Term 42 to Term 29)

Option 3 Time Delay Emergency to Normal (TDEN)

6 Position Card Cage  
Replace Driver Card in Position 4  
with Timer Card

9 Position Card Cage  
Replace Driver Card in Position 6  
with Timer Card

Option 4 Time Delay Engine Cooloff (TDEC)

6 Position Card Cage

Replace Blank Card in Position 3  
with Timer Card  
Add EC Relay to Motherboard

Add ERB Relay to Intelligence Panel

9 Position Card Cage

Replace Blank Card in Position 5  
with Timer Card  
Add EC Relay to Motherboard

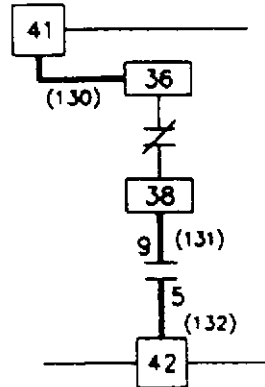

Option 5 Voltage/Frequency Sensing on Emergency

6 Position Card Cage

Replace BLANK Card in Position 5 or 6  
with Appropriate Sensing Card

9 Position Card Cage

Replace BLANK Card in Position 7,8,or 9  
with Appropriate Sensing Card

Option 6H Four Position Test Switch (FPSS)

Replaces Option 6B TEST Pushbutton

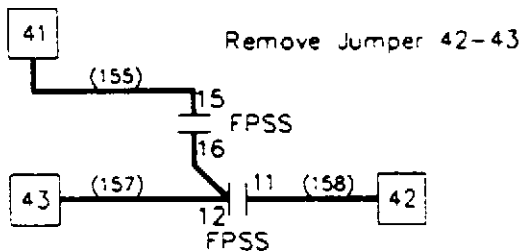
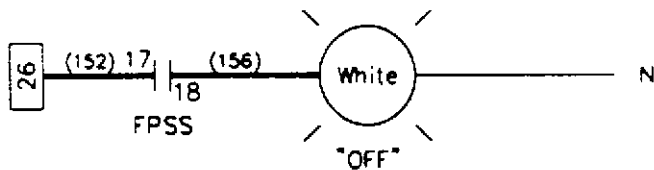
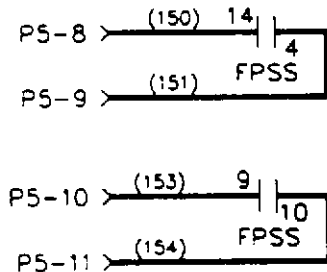

	9 10	11 12	4 14	15 16	17 18
TEST	X	X			
AUTO	X	X	X		
OFF					X
ENG. RUN	X		X	X	

Option 8C Bypass TDEN Timer (PBEN)

Remove Wire #17

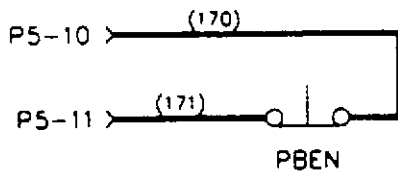

Option 8C Only

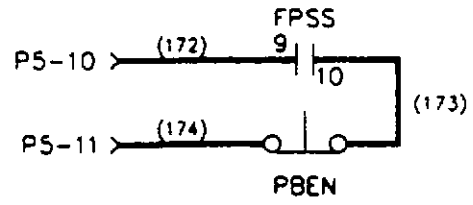

Option 8C w/Option 6H

Option 8D Bypass TDNE Timer (PBNE)

Remove Jumper

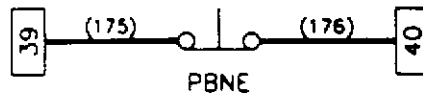

Option 9 Maintenance Selector Switch (MSS)



Remove wire #21

Option 12C Normal Position Light (NL)

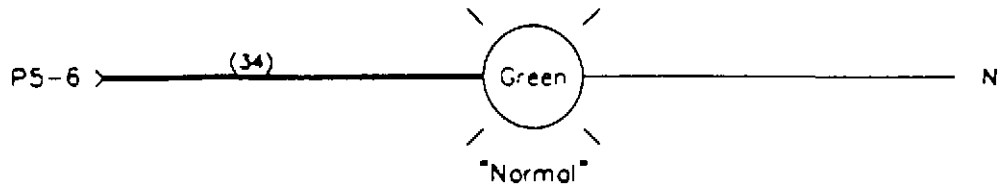

Option 12D Emergency Position Light

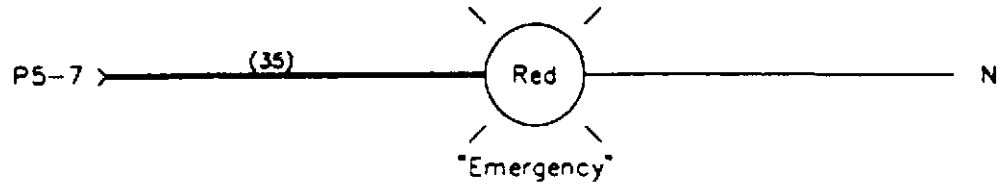

Option 12G Normal Source Light

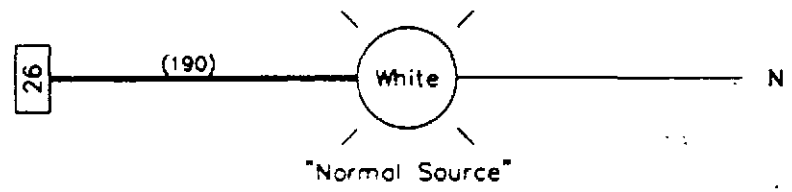

Option 12H Emergency Source Light

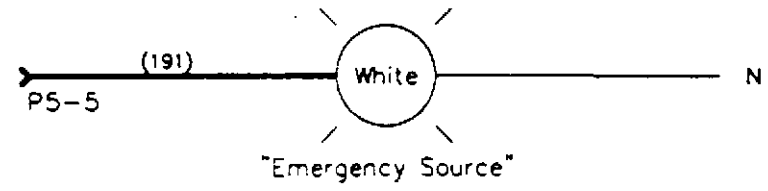

Option 12L Trip Indicator Light Only available with Option 16

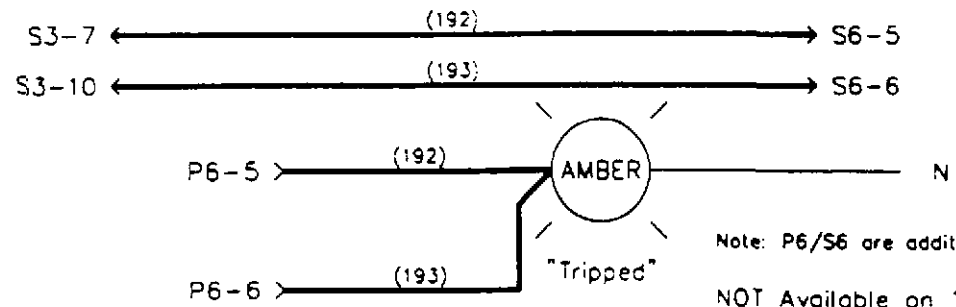

Note: P6/S6 are additional 12 pin plug/socket  
NOT Available on 100 amp units

Option 14C Normal Auxiliary Relay (NRA)

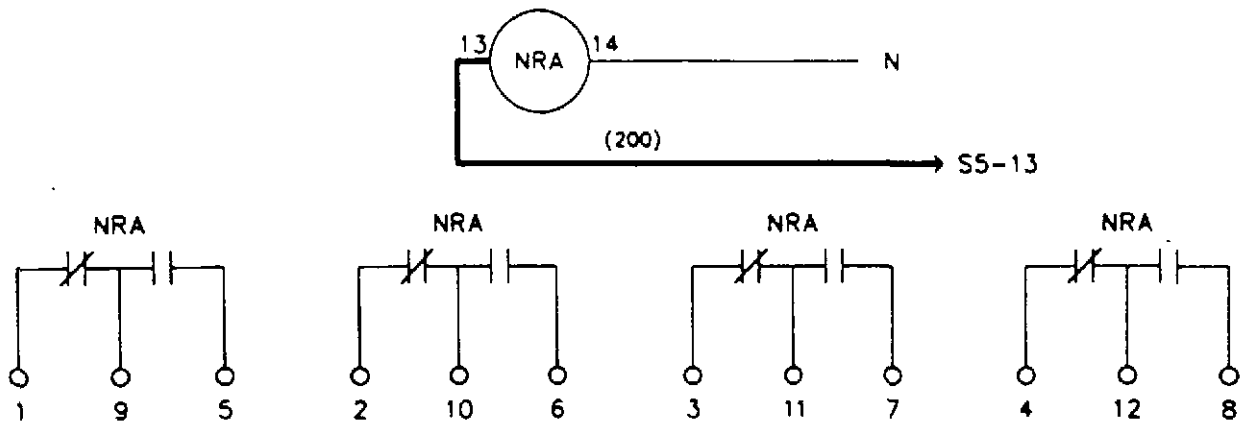

Option 14D Emergency Auxiliary Relay

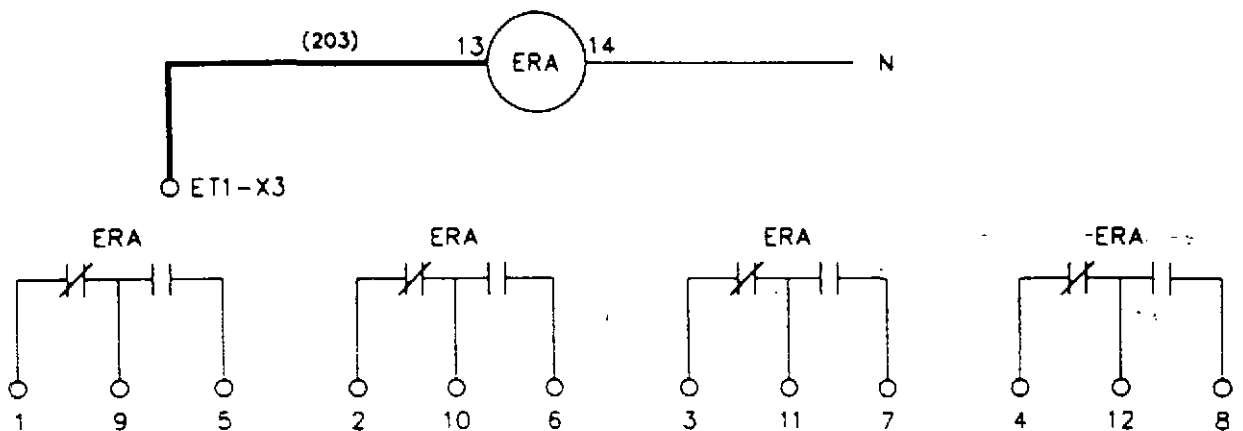

Customer Contacts are on Relay Socket

NRA/ERA Relay Socket

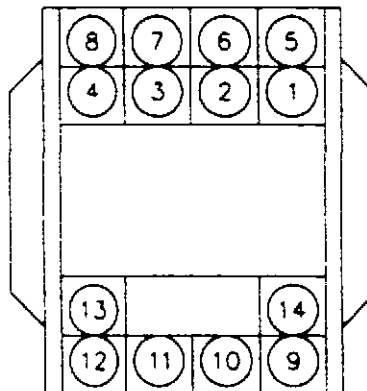

Option 16B Thermal Magnetic Trips

\*bell Alarms must be installed in the MCCB

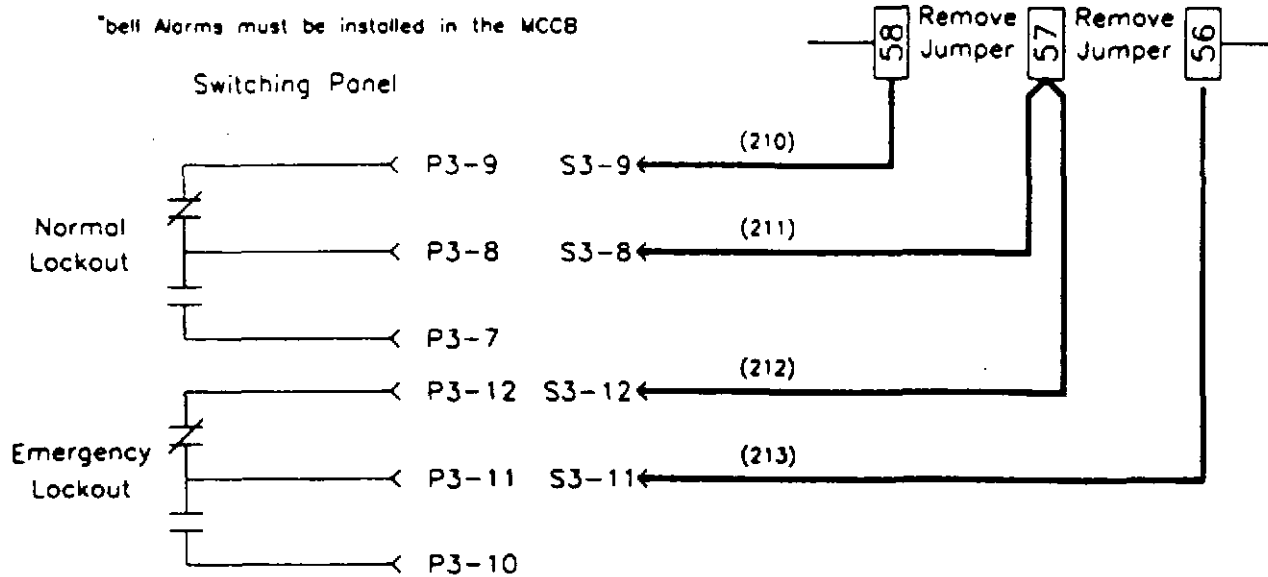

Option 16N Thermal Magnetic Trip on Normal

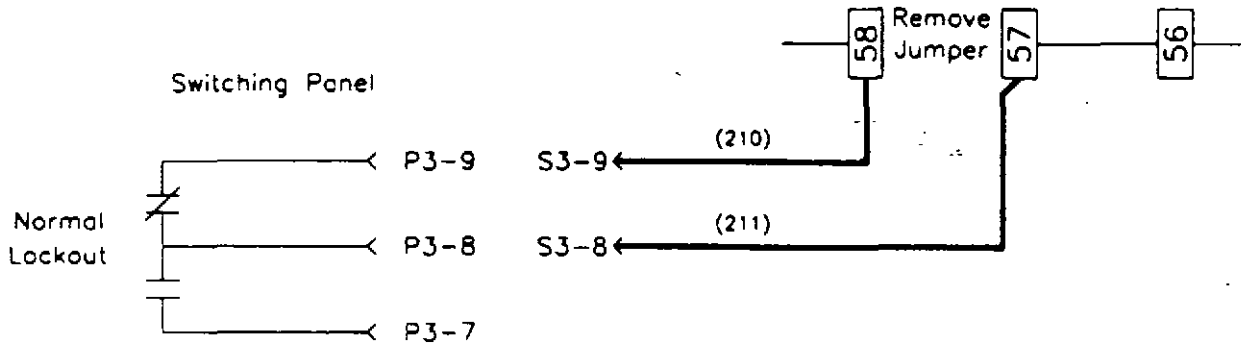

Option 16E Thermal Magnetic Trip on Emergency

\*bell Alarms must be installed in the MCCB

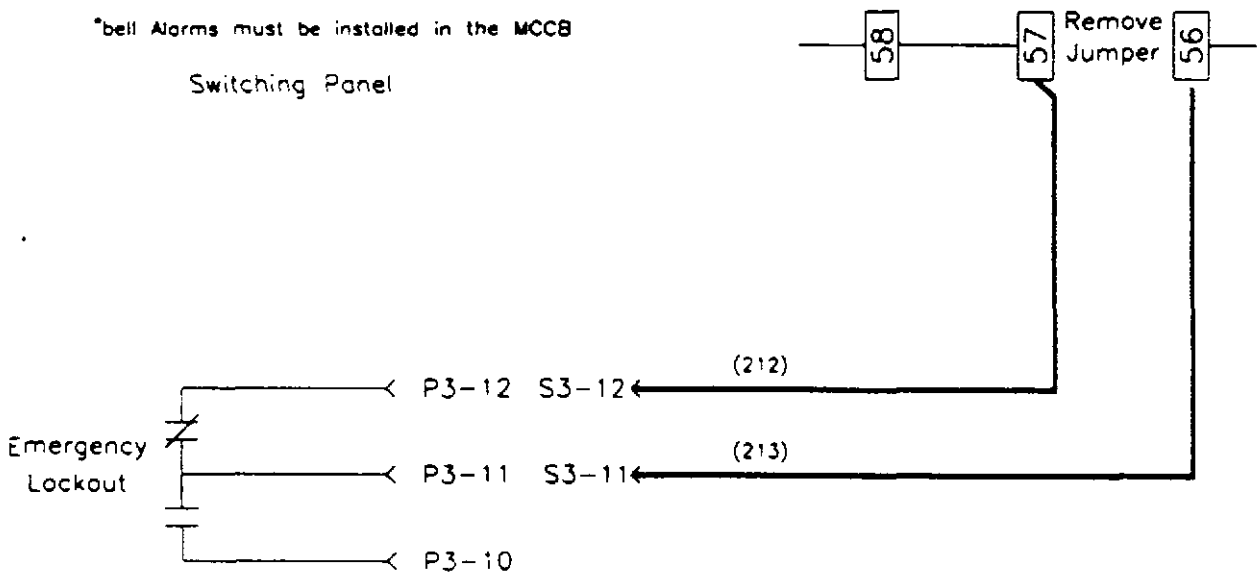

Option 23C Plant Exerciser

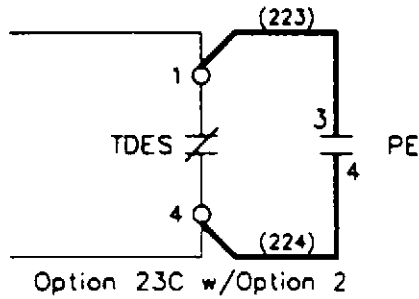
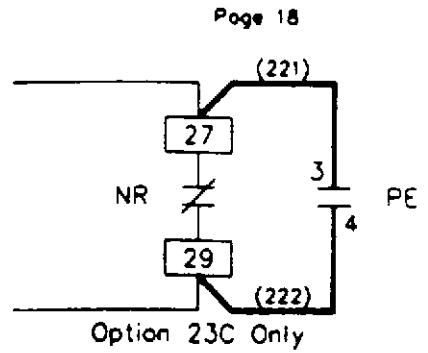
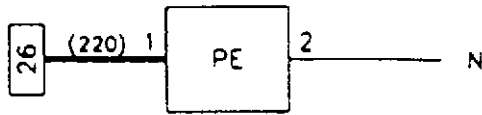

Option 23D Plant Exerciser

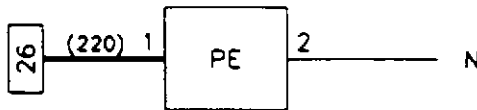

Remove Wire #16

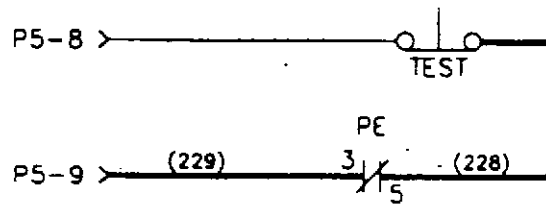

Option 23I Plant Exerciser

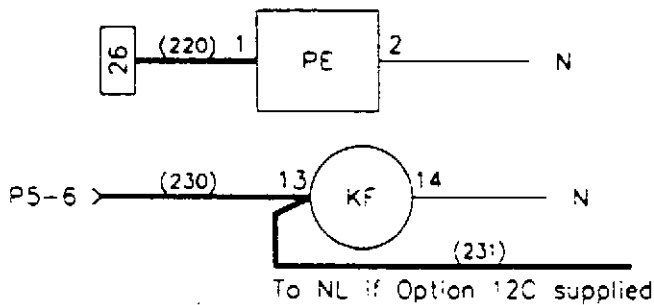

Remove Wire #16

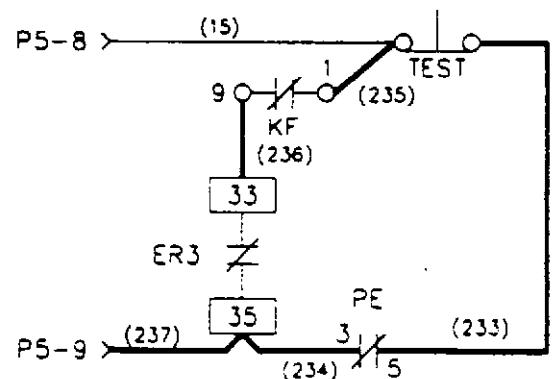

Option 23G Plant Exerciser

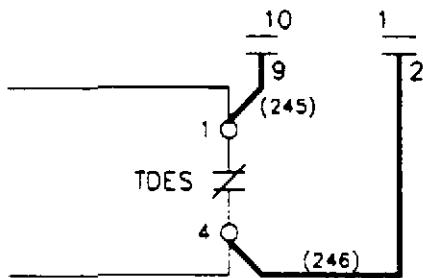
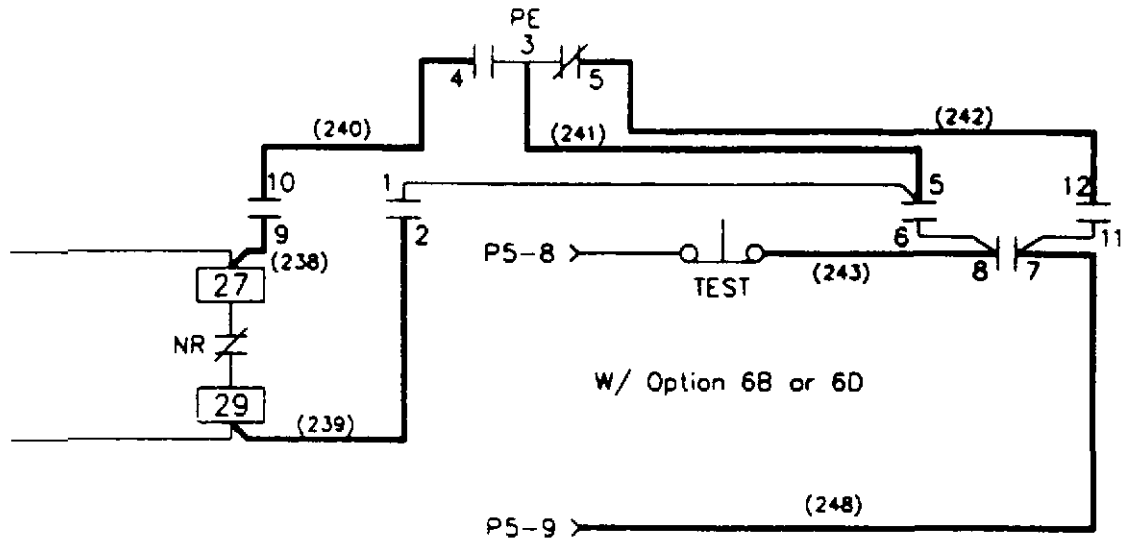

Option 23G w/Option 2

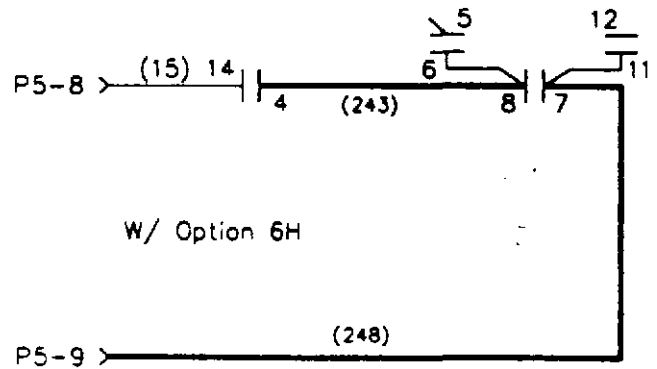

☐ Option 23J Plant Exerciser

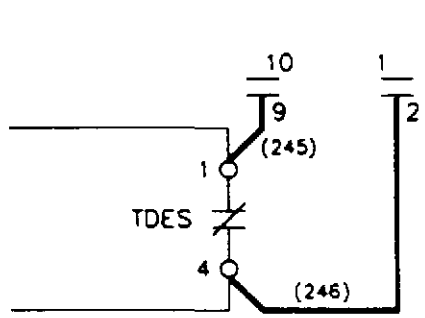
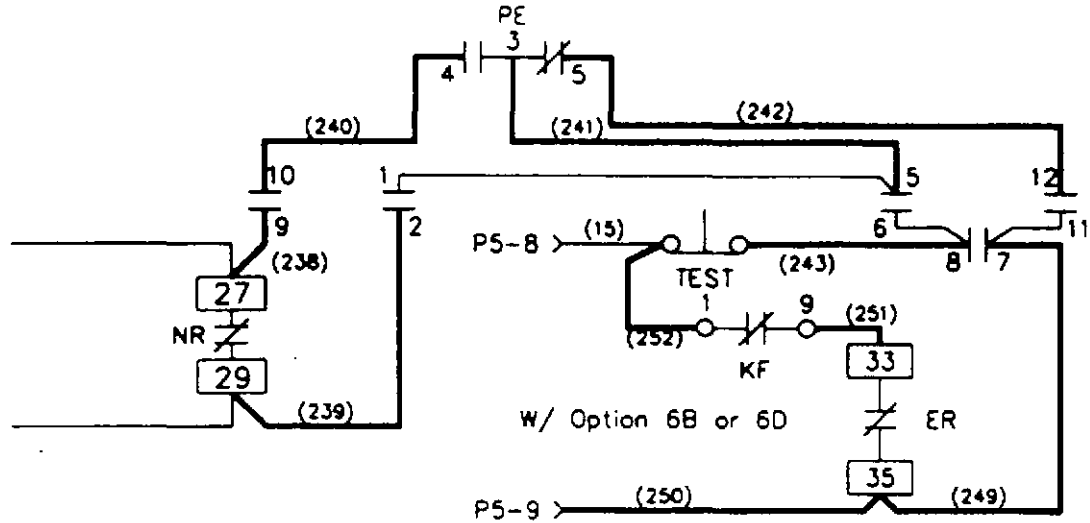
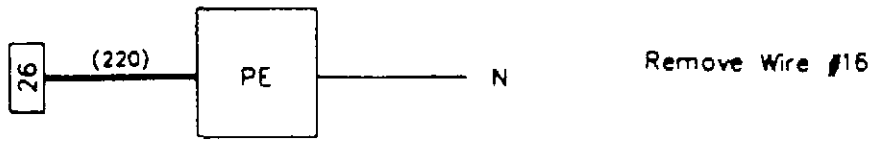

Option 23G w/Option 2 or  
Option 2 and 4

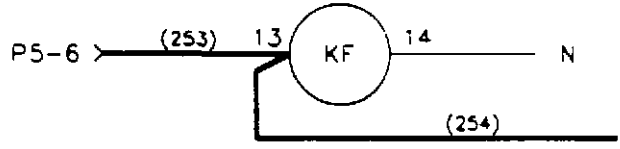
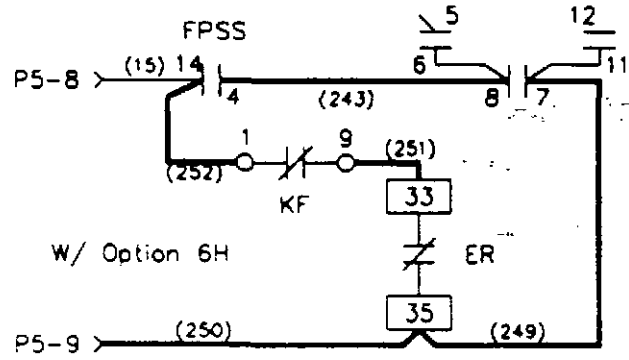

To NL if Option 12C is supplied

Option 29E Manual Return to Normal

DO NOT supply Option 3 with this option!

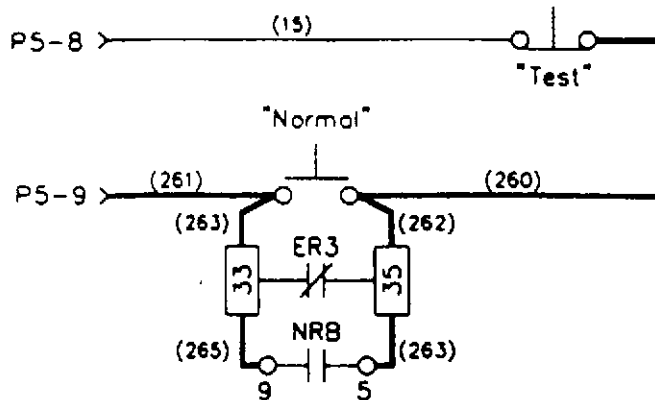

Remove Wire #16

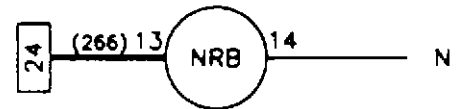

Option 29J Automatic/Manual Return to Normal

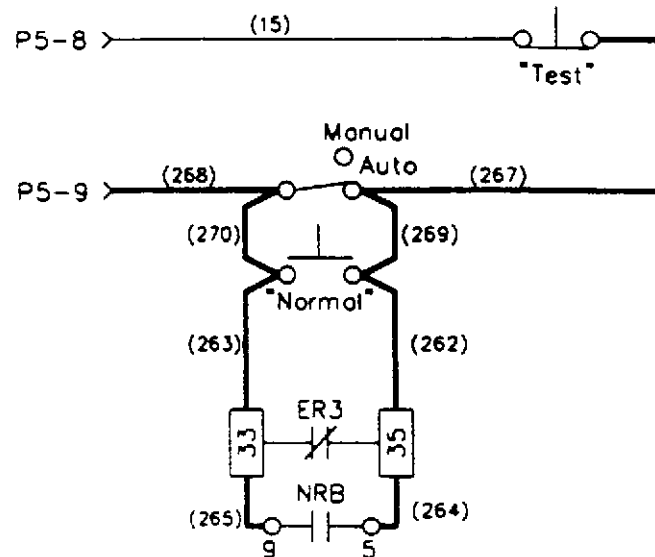

Remove Wire #16

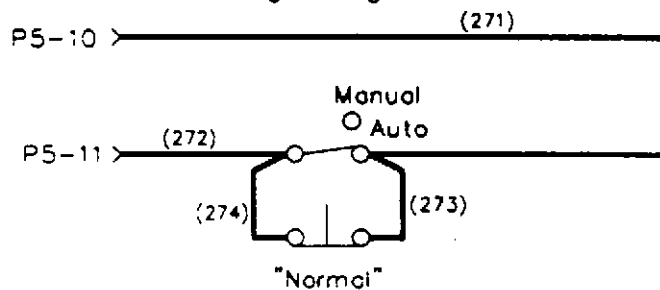
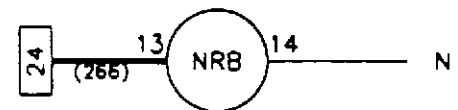

Option 29G Automatic/Manual Operation

NOT UL Listed!

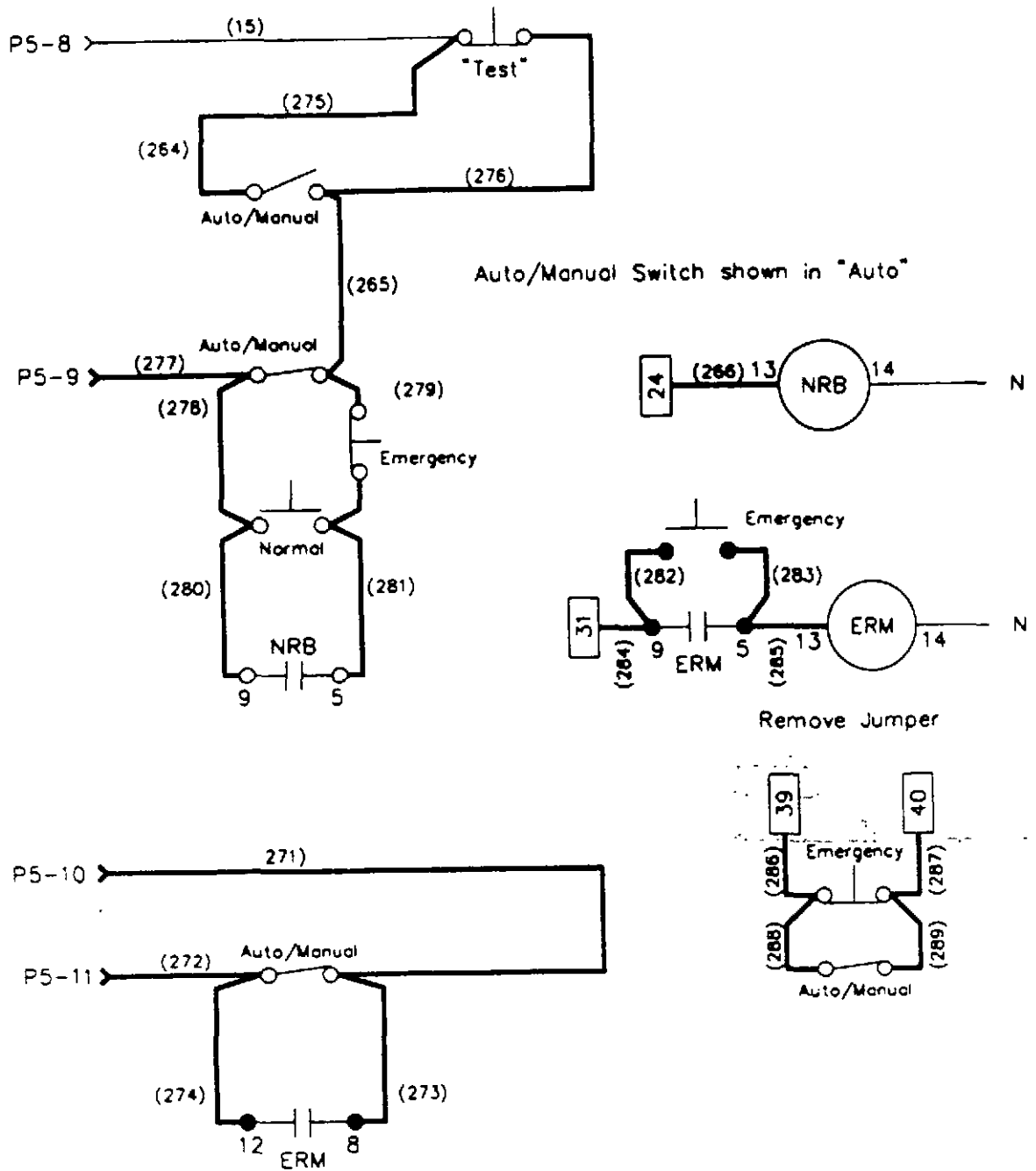

DO NOT apply a UL label !!!

Option 37 Service Disconnect

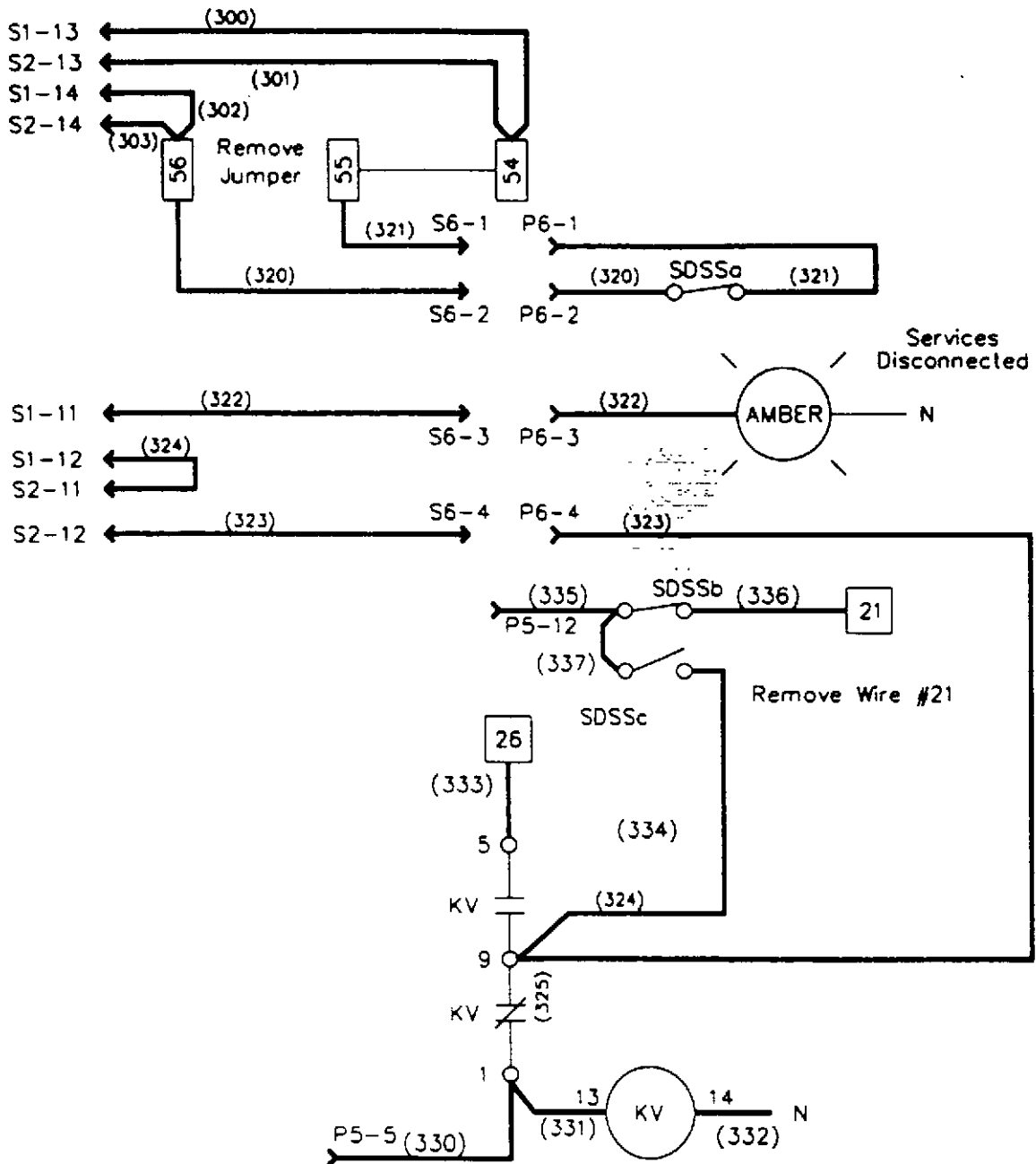
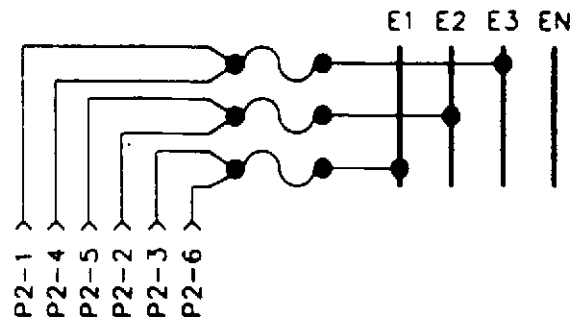
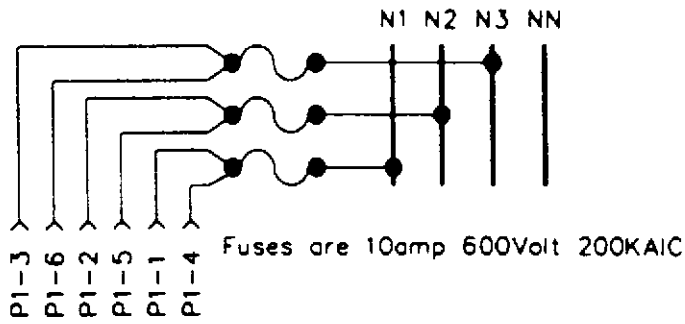

Option 10 B/D - Preferred Source Selector Switch

Source 1  
Source 2

X	1-2
X	3-4
X	5-6
X	7-8
X	9-10
X	11-12
X	13-14
X	15-16
X	17-18
X	19-20
X	21-22
X	23-24
X	25-26
X	27-28
X	29-30
X	31-32
X	33-34
X	35-36
X	37-38
X	39-40
X	41-42
X	43-44
X	45-46
X	47-48
X	49-50
X	51-52
X	53-54
X	55-56
X	57-58
X	59-60
X	61-62
X	63-64
X	65-66
X	67-68
X	69-70
X	71-72
X	73-74
X	75-76
X	77-78
X	79-80

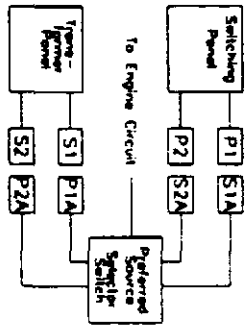
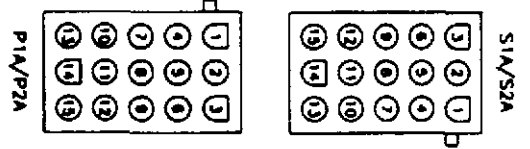
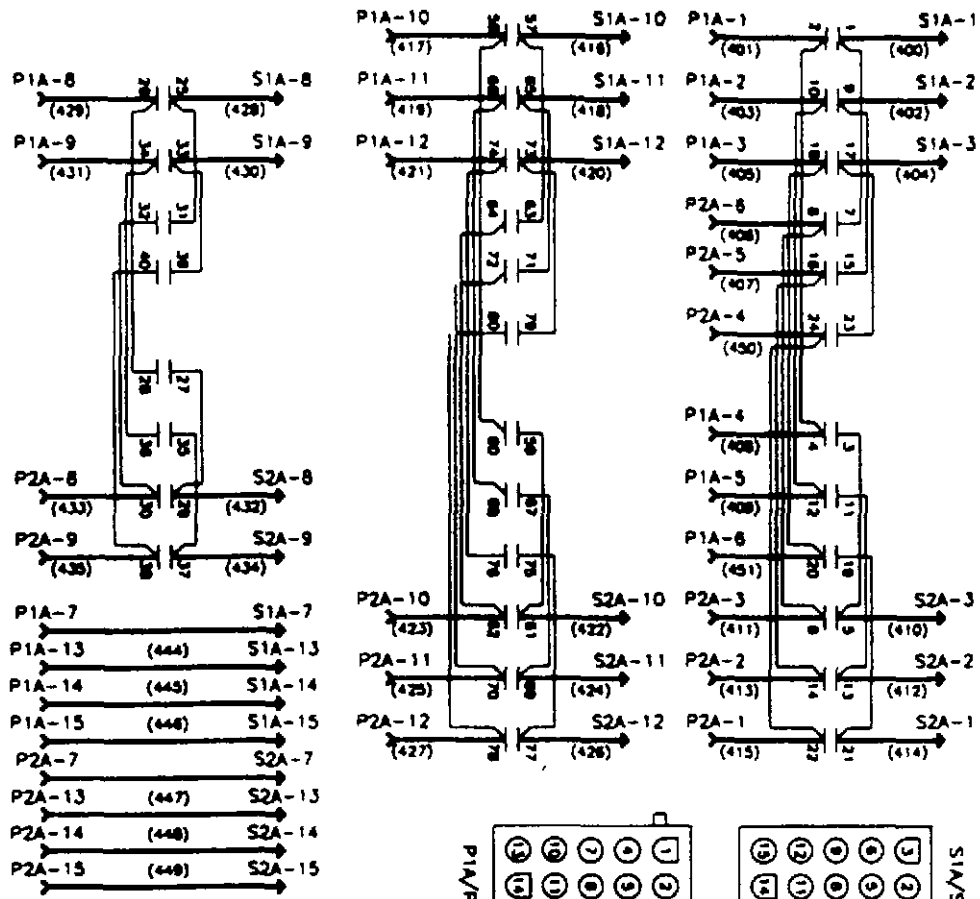

Option 10B

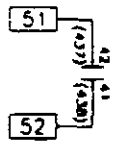

Engine Start Circuits

Option 10D

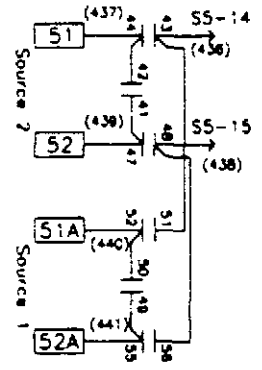

# **Cutler-Hammer Beaver, PA**

Automatic Transfer Switch

**GENSWITCH**  
Type ATVM Wiring Diagrams

Version 1.0 June 28, 1995

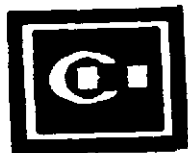

**Cutler-Hammer**

---

**EATON**

Copyright 1995 by Eaton/Cutler Hammer Inc.  
All rights reserved

Page

Date

ATVMU100.DWG	28 Jun 95
ATVMUPPR.DWG	28 Jun 95
ATVMOCFMR.DWG	28 Jun 95
ATVMINTL.DWG	27 Jun 95
ATVMIN23.DWG	27 Jun 95
ATVM_06.DWG	27 Jun 95

Plug - Pin assignments for the GENSWITCH Transfer Switch

P1 - Switching Panel

S1 - Transformer Panel

1	Normal	N1	Phase A
2	Normal	N2	Phase B
3	Normal	N3	Phase C
4	Normal	N1	Phase A
5	Normal	N2	Phase B
6	Normal	N3	Phase C
7	N Aux Sw #1	N.O.	
8	N Aux Sw #1	C	Limit Switch
9	N Aux Sw #1	N.C.	
10			
11			
12			
13			
14			
15			

P2 - Switching Panel

S2 - Transformer Panel

1	Emergency	E3	Phase C
2	Emergency	E2	Phase B
3	Emergency	E1	Phase A
4	Emergency	E3	Phase C
5	Emergency	E2	Phase B
6	Emergency	E1	Phase A
7	E Aux Sw #1	N.O.	
8	E Aux Sw #1	C	Limit Switch
9	E Aux Sw #1	N.C.	
10			
11			
12			
13			
14			
15			

P3 - Switching Panel to  
S3 - Transformer Panel

- 1
- 2
- 3
- 4 Motor Bridge "AC" Ia
- 5 Motor Bridge "AC" Ia
- 6
- 7
- 8
- 9
- 10
- 11
- 12

P4 - Transformer Panel to  
S4 - Intelligence Panel

- 1 Motherboard 1
- 2 Motherboard 2
- 3 Motherboard 3
- 4 Motherboard 4
- 5 Motherboard 5
- 6 Motherboard 6
- 7 Motherboard 7
- 8 Motherboard 8
- 9 Motherboard 9
- 10 Motherboard 10
- 11 Reserved
- 12 Reserved
- 13 Reserved
- 14 Reserved
- 15

S5 - Transformer Panel to  
P5 - Intelligence Panel (Door)

- 1 Normal from NLS
- 2 Emergency from ELS
- 3 Control Neutral
- 4 Normal Control Power
- 5 Emergency Control Power
- 6 Normal Position Light
- 7 Emergency Position Light
- 8 Normal Logic Interrupt (Test Pushbutton)
- 9 Normal Logic Interrupt (Test Pushbutton)
- 10 Emergency Logic Interrupt
- 11 Emergency Logic Interrupt
- 12 Transfer Motor Operate
- 2213 NRA Relay Power
- 14 Engine Start Circuit Source 2

15 Engine Start Circuit Source 2

S7a - g Voltage Selector - Socket  
P7 - Plug

1	NT3
2	NT4
3	NT1
4	ET1
5	ET4
6	ET3

# Cutler-Hammer Automatic Transfer Switch Wiring Diagrams

## Directions for Use

The drawing package can be used as a point to point wiring diagram for maintenance and diagnostic purposes for the GENSWITCH (Catalog ATVM) Transfer Switches, 30 - 1000 Ampere, all voltages.

This document contains the following wiring information:

- Basic Switching Panel Wiring
- Basic wiring diagrams for the transformer and intelligence panels.
- Wiring for all normally available features. (Options)
- Legend Sheet describing symbols used throughout this document.

## Legend Sheet

BR	Bridge Rectifier
EL	Emergency Position Indicator Light
ER	Emergency Relay
ERA	Emergency Auxiliary Relay
ERB	Emergency Auxiliary Relay
ETx	Emergency Transformer
Ex	Emergency Power Terminal x
KB	Brake Relay
KF	Failsafe Relay
NL	Normal Position Indicator Light
NR	Normal Relay
NRA	Normal Auxiliary Relay
NRB	Normal Auxiliary Relay
NTx	Normal Transformer x
Nx	Normal Power Terminal x
PE	Plant Exerciser Clock
PSDR	Pretransfer Signal Relay
PSDT	Pretransfer Signal Timer
Px-y	"Plug Number x, Pin Number y"
Sx-y	"Socket Number x, Pin Number y"
TDEC	Time Delay Engine Cooloff
TDEN	Time Delay Emergency to Normal
TDES	Time Delay Engine Start
TDN	Time Delay Neutral
TDNE	Time Delay Normal to Emergency

# Switching Panel (150 - 1000 Ampere, 2,3,or 4 pole)

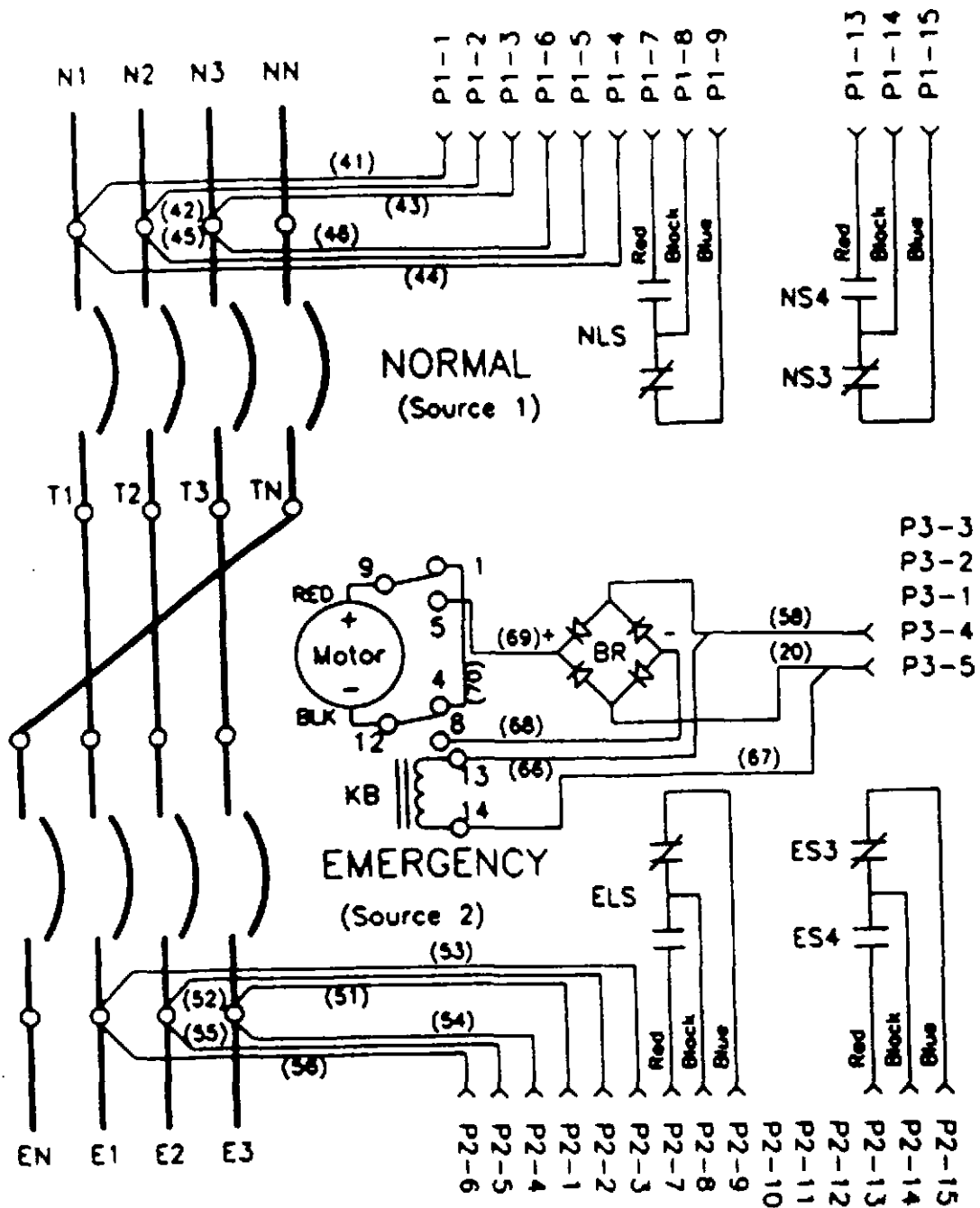

NLS/NS3/NS4 and ELS/ES3/ES4 are mounted internally in the switching devices  
 NS3/NS4 and ES3/ES4 are ONLY supplied when Option 32 is supplied

# 100 Amp Switching Panel Assembly

GENSWITCH (Col. No. ATHM ONLY)

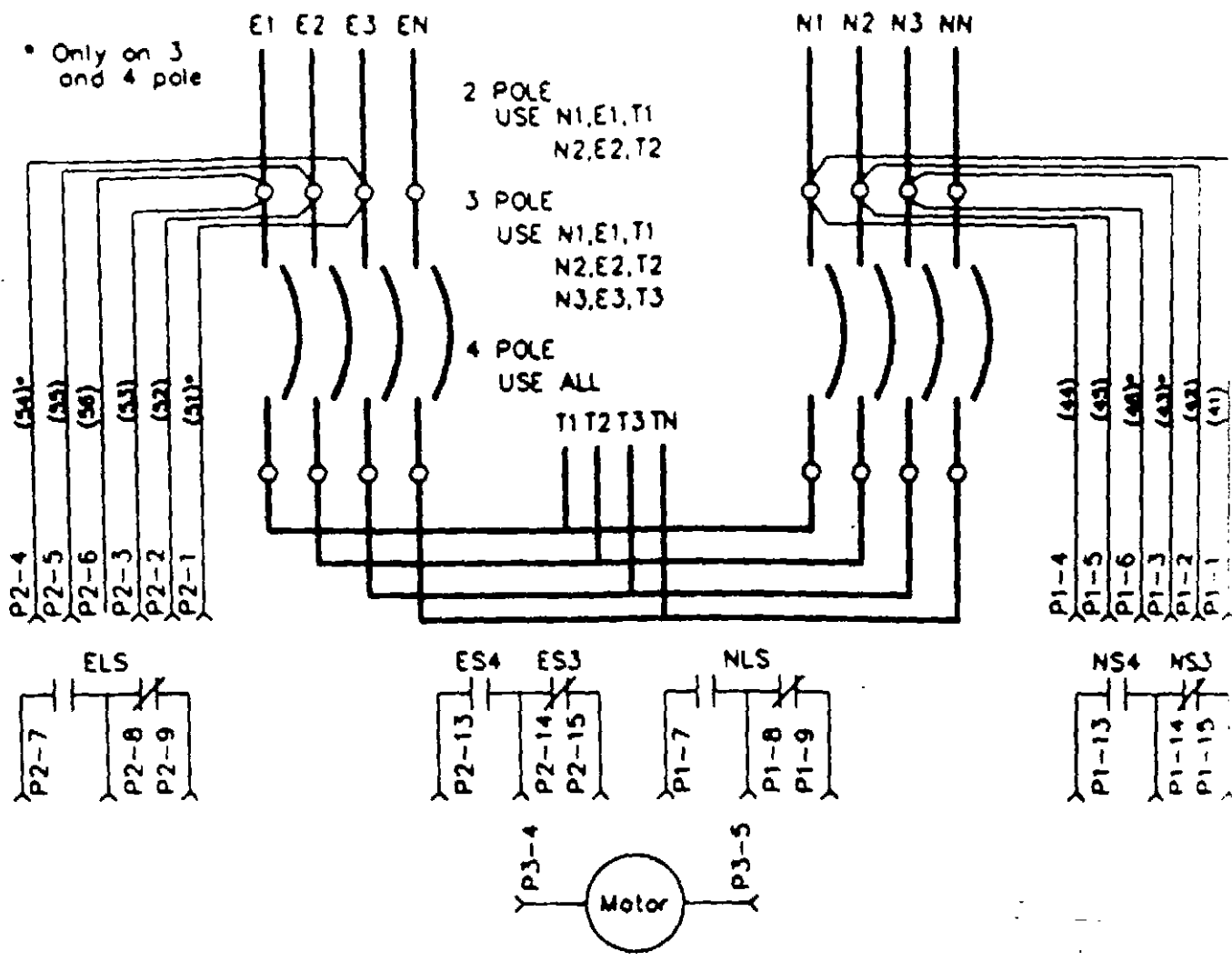

NLS and ELS are located on the mechanism  
 NS3/NS4 and ES3/ES4 are ONLY supplied when Option 32 is supplied  
 NS3/NS4 and ES3/ES4 are mounted internally in the switching devices

# Transformer Panel

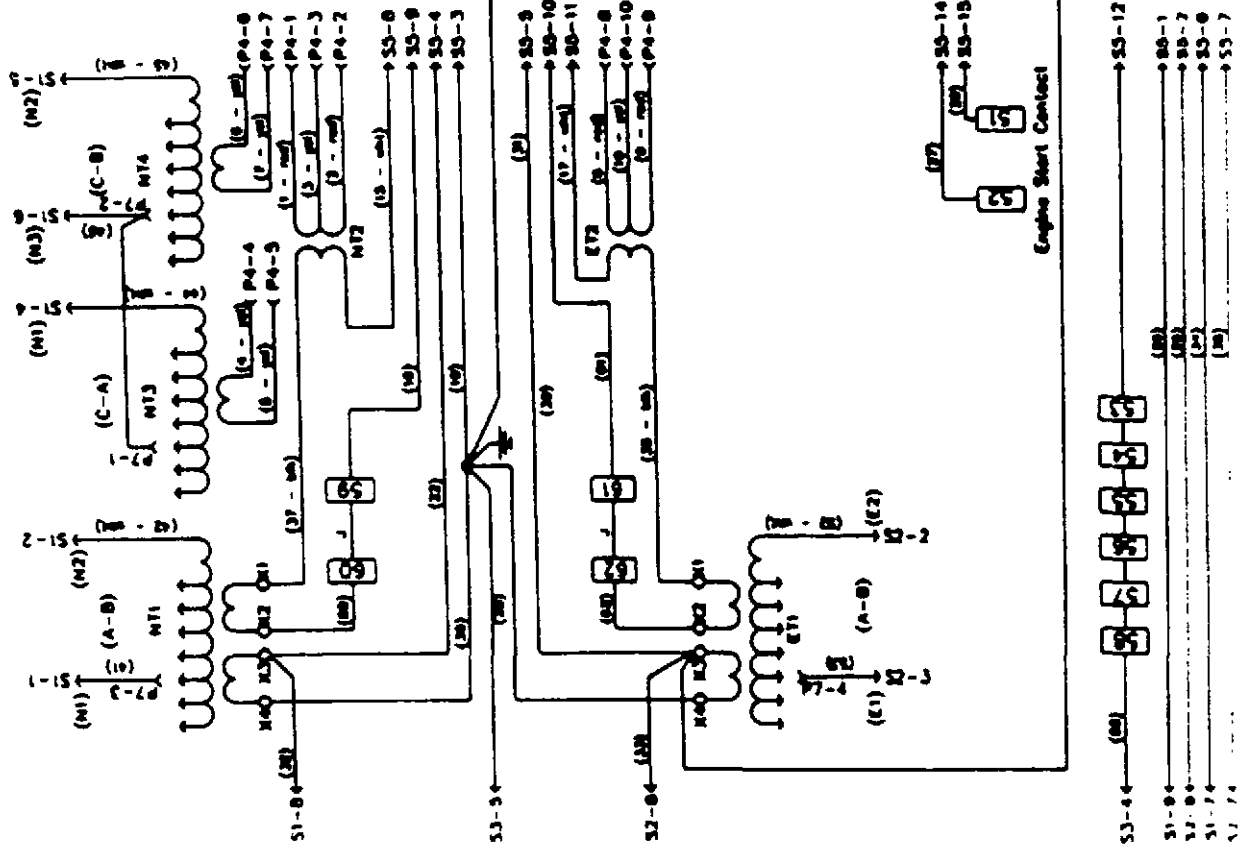

# P7/S70-g Detail

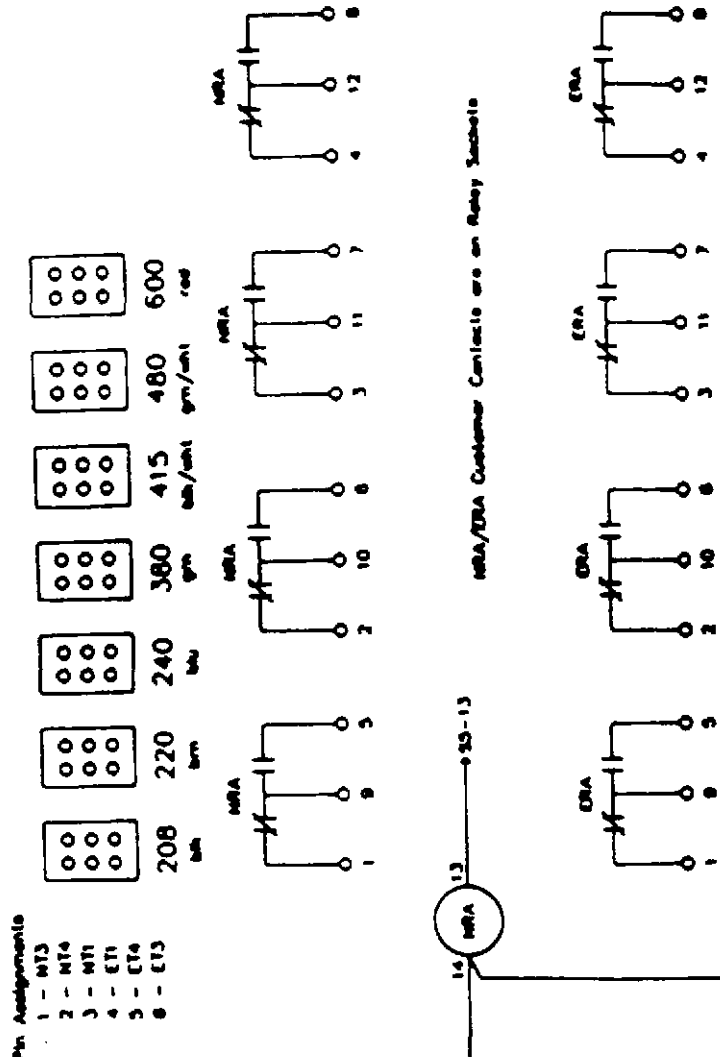

MRA/ERA Customer Contacts are on Relay Substrate

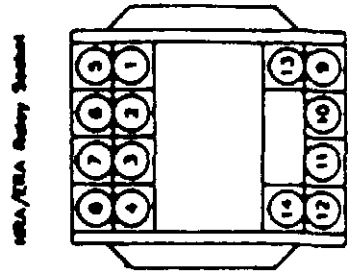

**Intelligence Panel  
Single Board Controller**

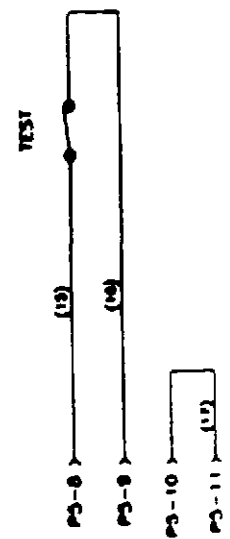
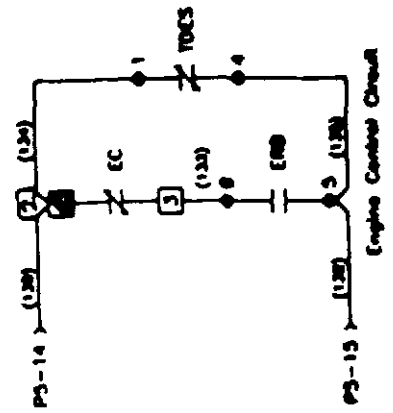
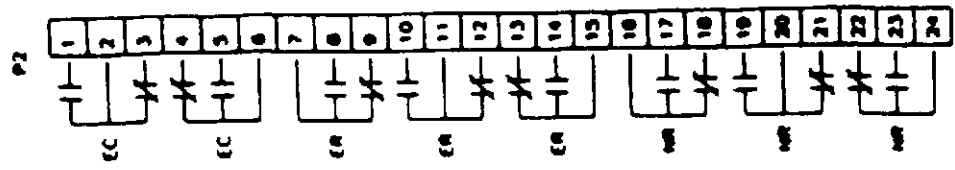
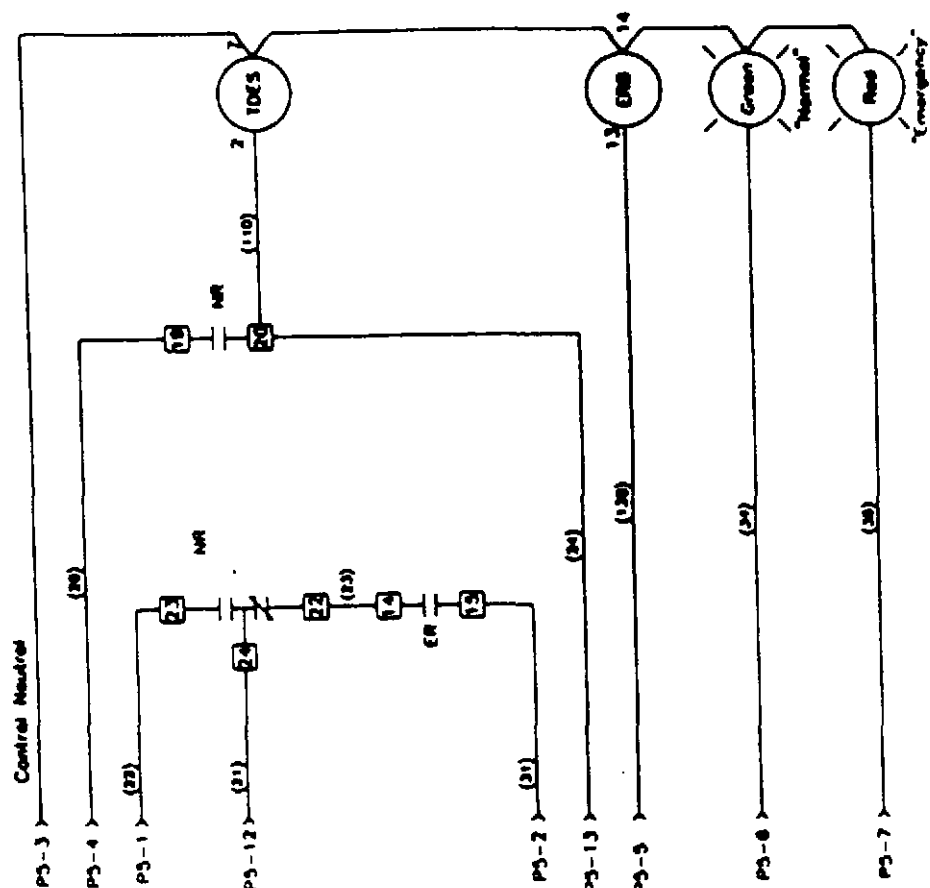
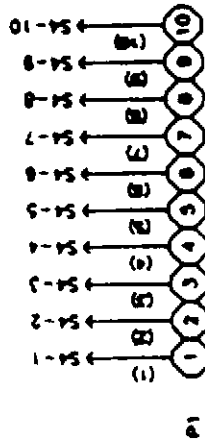

# Intelligence Panel

Single Board Controller w/09123J

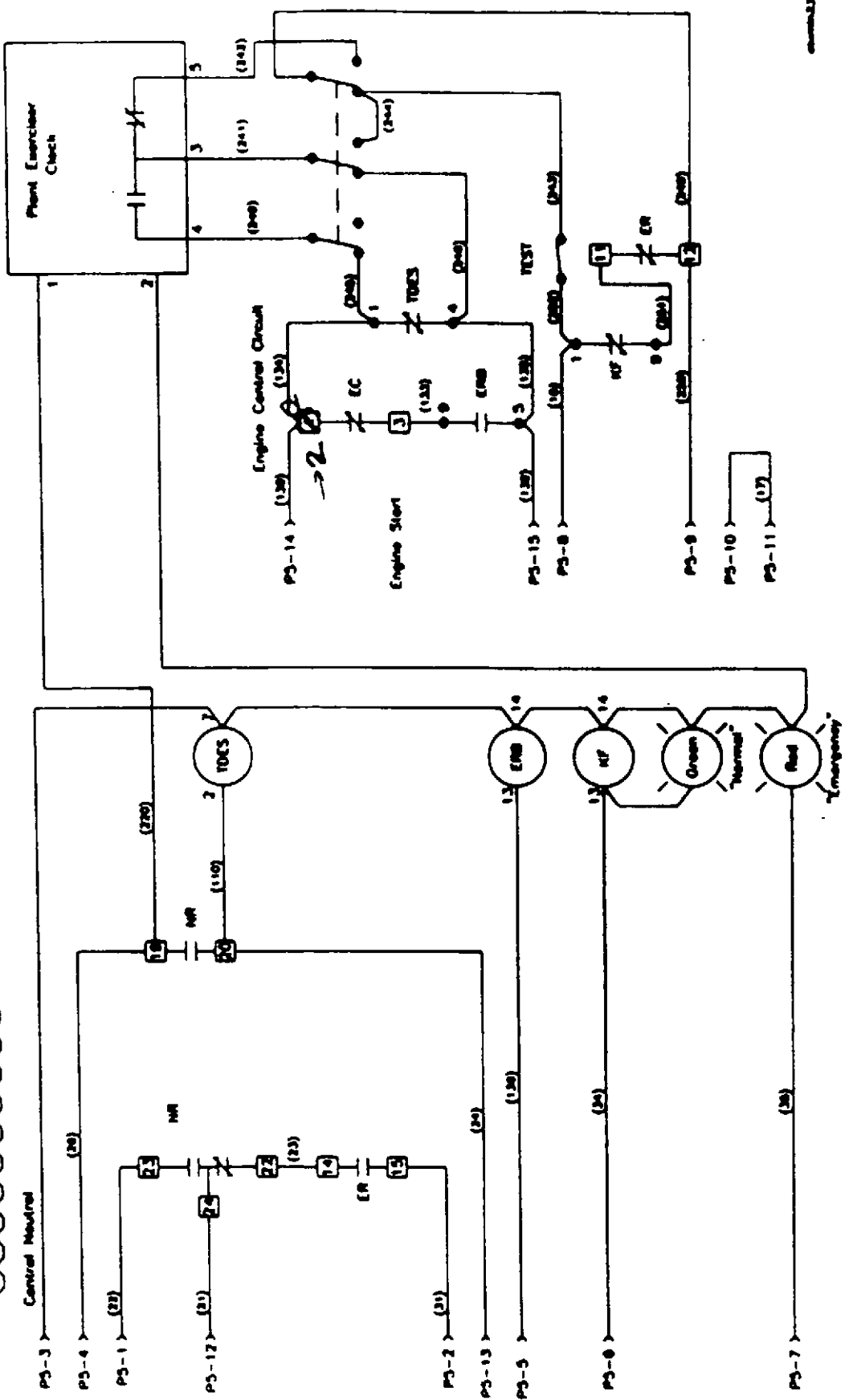
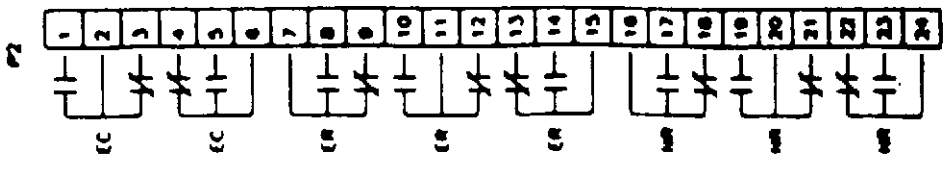
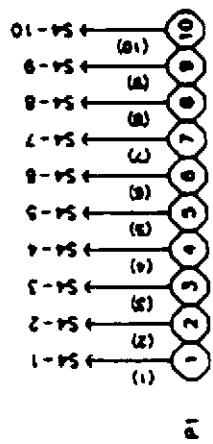

Option 32 Time Delay Neutral

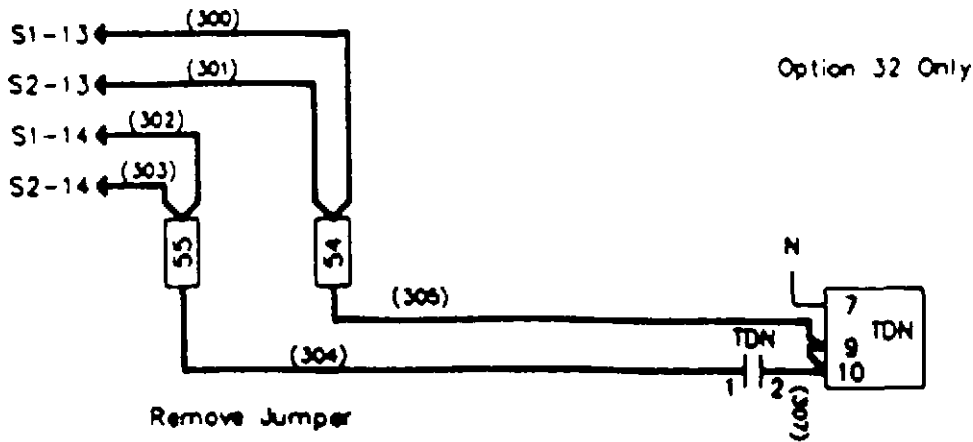

Option 35 Pretransfer Signal Device

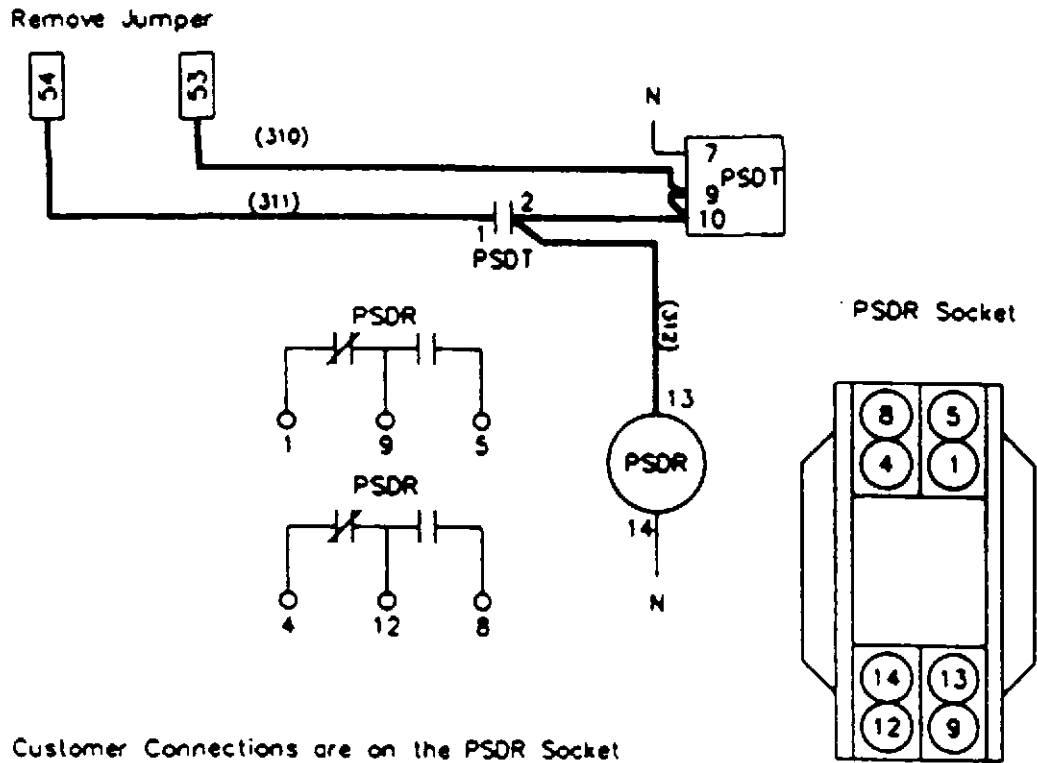

**Cutler-Hammer  
Beaver, PA**

Automatic Transfer Switch

Type ATVE Wiring Diagrams

Version 2.0    May 8, 1994

Copyright 1995 by Eaton/Cutler-Hammer Inc.

Page No.

Date

VUPPER.DWG	10 Feb 95
UPPR100.DWG	8 May 95
ATVEXFMR.DWG	8 May 95
VEMINTL.DWG	8 May 95
VEM01.DWG	8 May 95
VEM02.DWG	8 May 95
VEM03.DWG	8 May 95
VEM04.DWG	8 May 95
VEM04A.DWG	6 Apr 95
VEM05.DWG	8 May 95
VEM06.DWG	8 May 95
VEM07.DWG	6 Apr 95
VEM08.DWG	13 Apr 95

Plug - Pin assignments for the ELECTROMECHANICAL LOGIC Transfer Switch.

P1 - Switching Panel

S1 - Transformer Panel

1	Normal	N1	Phase A
2	Normal	N2	Phase B
3	Normal	N3	Phase C
4	Normal	N1	Phase A
5	Normal	N2	Phase B
6			
7	N Aux Sw #1	N.O.	
8	N Aux Sw #1	C	
9	N Aux Sw #1	N.C.	
10	N Aux Sw #2	N.O.	
11	N Aux Sw #2	C	
12	N Aux Sw #2	N.C.	
13	N Aux Sw #3	N.O.	
14	N Aux Sw #3	C	
15	N Aux Sw #3	N.C.	

P2 - Switching Panel

S2 - Transformer Panel

1	Emergency	E1	Phase A
2	Emergency	E2	Phase B
3	Emergency	E3	Phase C
4	Emergency	E1	Phase A
5	Emergency	E2	Phase B
6			
7	E Aux Sw #1	N.O.	
8	E Aux Sw #1	C	
9	E Aux Sw #1	N.C.	
10	E Aux Sw #2	N.O.	
11	E Aux Sw #2	C	
12	E Aux Sw #2	N.C.	
13	E Aux Sw #3	N.O.	
14	E Aux Sw #3	C	
15	E Aux Sw #3	N.C.	

P3 - Switching Panel to  
S3 - Transformer Panel

1		
2		
3		
4	Motor	Bridge "AC" In
5	Motor	Bridge "AC" In
6		
7	Lockout (Normal)	N C
8		COM
9		N.O.
10	Lockout (Emergency)	N.C.
11		COM
12		N.O.

S5 - Transformer Panel to  
P5 - Intelligence Panel (Door)

1	Normal Operate
2	Emergency Operate
3	Control Neutral
4	Normal Control Power
5	Emergency Control Power
6	Normal Position Light
7	Emergency Position Light
8	NR Relay Circuit
9	
10	
11	
12	Motor Circuit
13	NR Relay Output
14	Engine Start Circuit Source 2
15	Engine Start Circuit Source 2

S6 - Transformer Panel to  
P6 - Intelligence Panel (Door)

1	Motor Circuit Interrupt TB 53
2	Motor Circuit Interrupt TB 54
3	Motor Circuit Interrupt TB 55
4	N. Trip
5	E Trip

# Switching Panel (150 - 1000 Ampere, 2,3,or 4 pole)

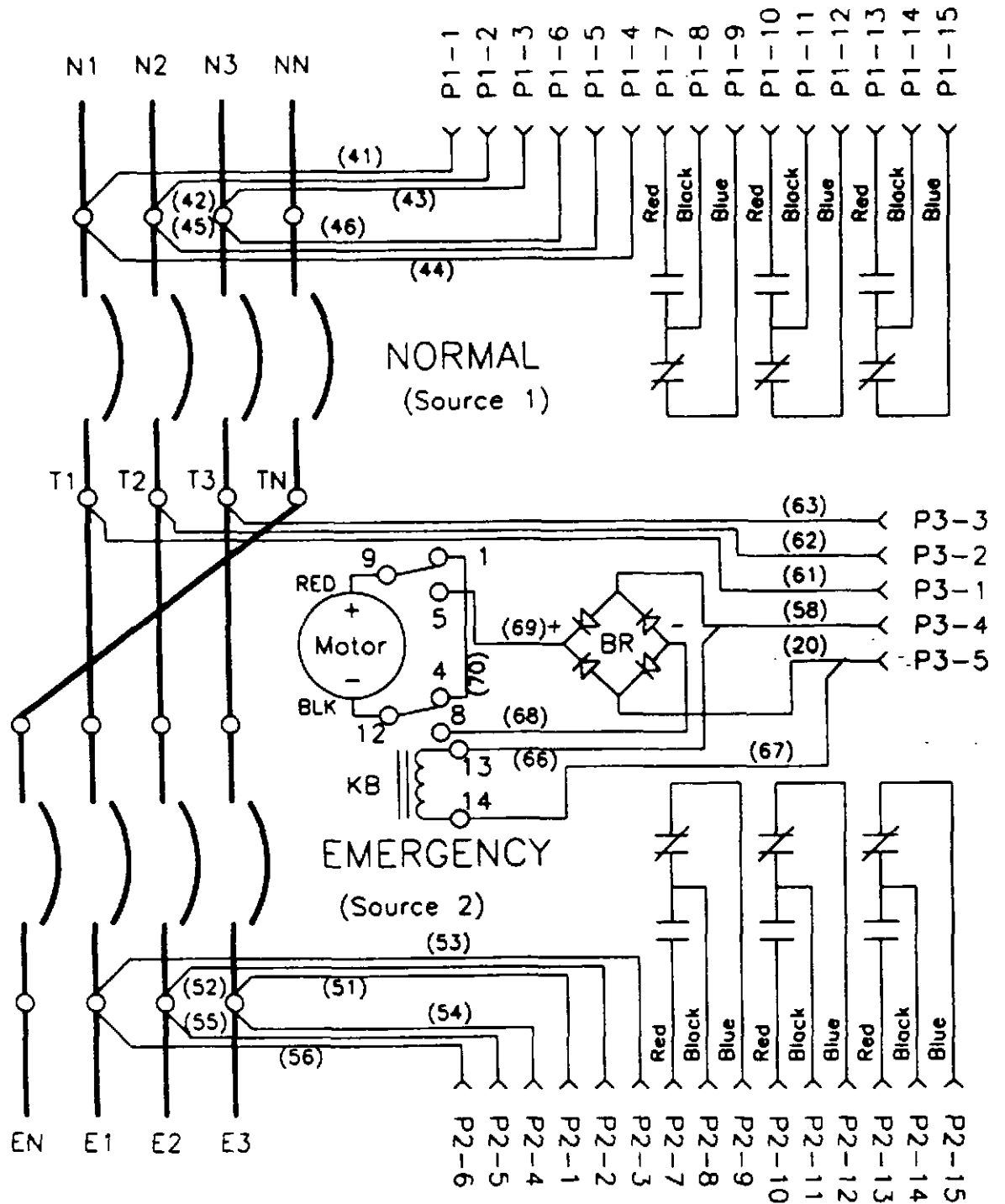

# 100 Amp Switching Panel Assembly

Cat. No. ATHS or ATHE ONLY

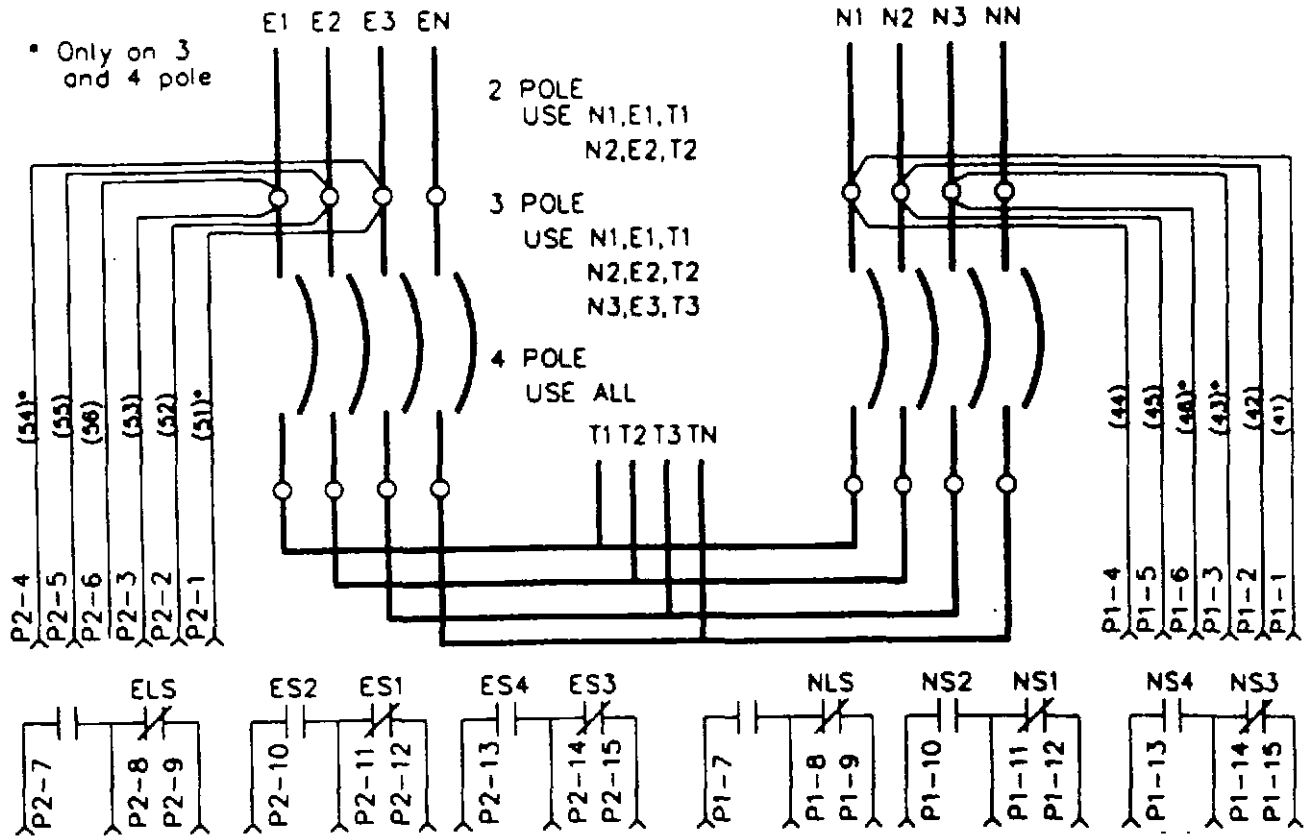

NLS and ELS are located on the mechanism

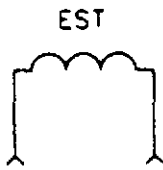

SHUNT TRIP  
(OPTIONAL)

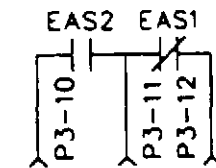

(A6) BELL ALARM  
LOCKOUT  
(OPTIONAL)

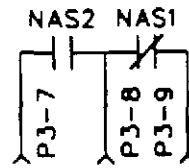

BELL ALARM  
LOCKOUT  
(OPTIONAL)

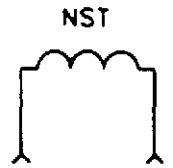

SHUNT TRIP  
(OPTIONAL)

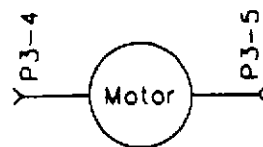

# Electromechanical Logic Transformer Panel

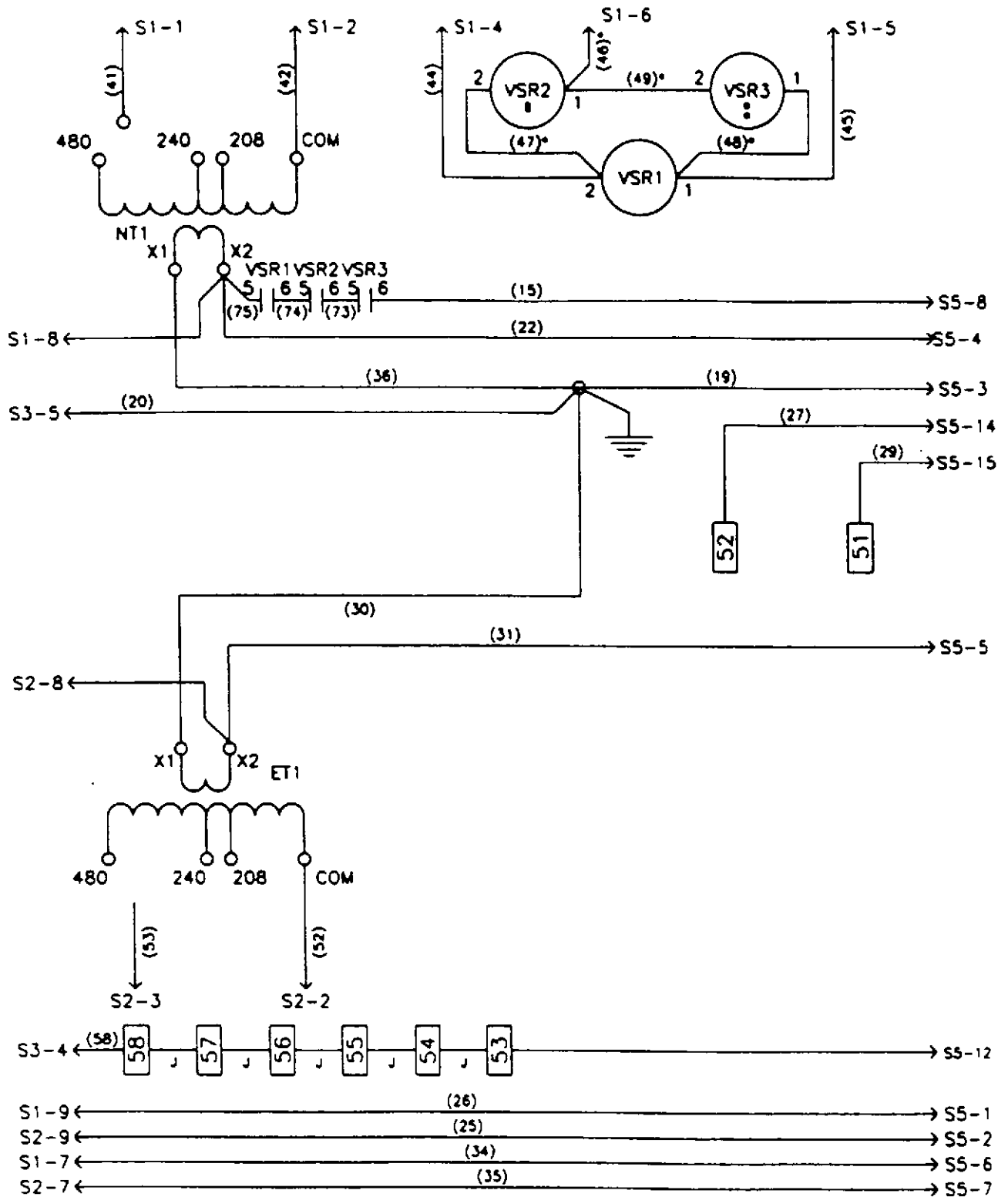

# Electromechanical Intelligence Panel

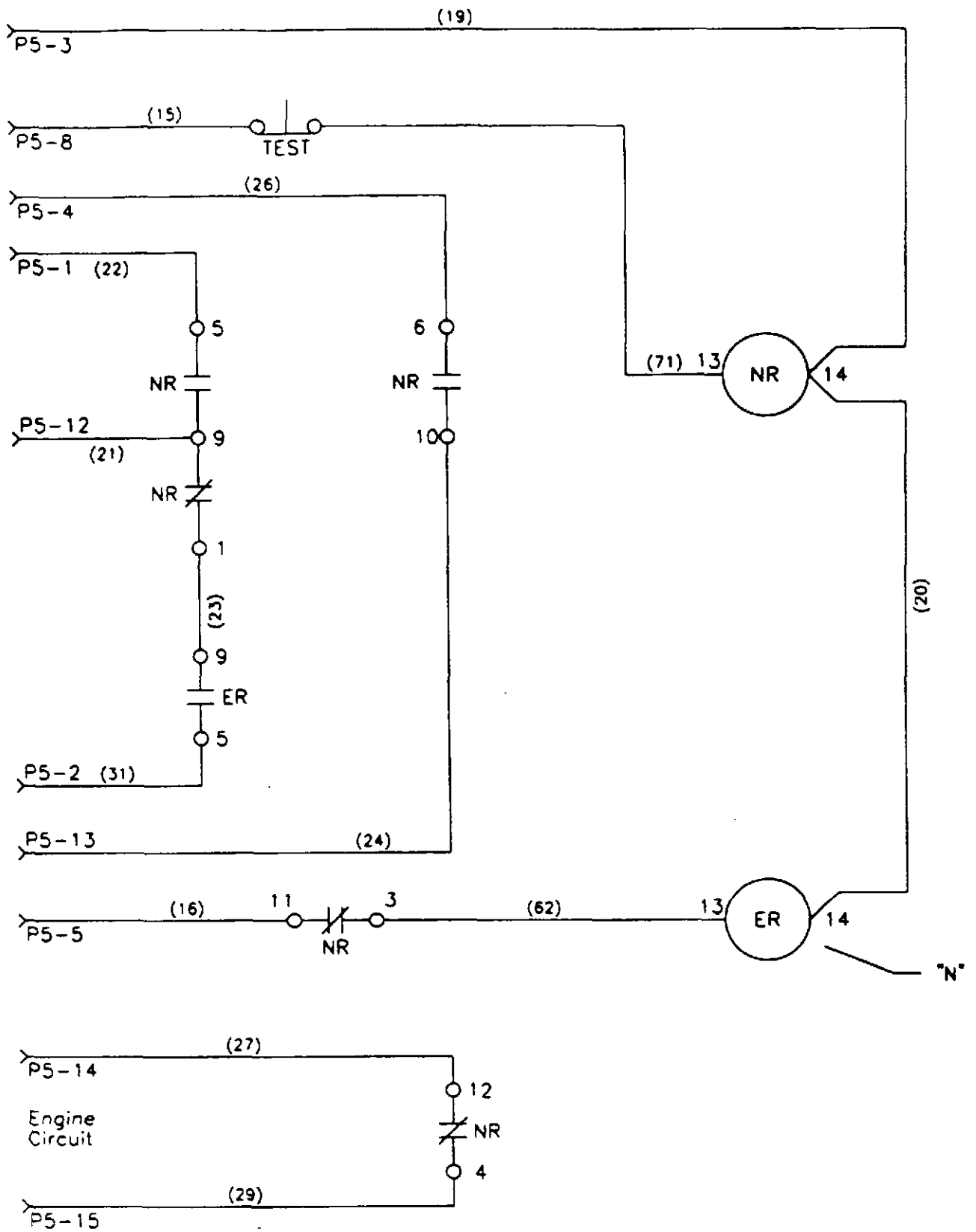

Option 1 (TDNE) Time Delay Normal to Emergency

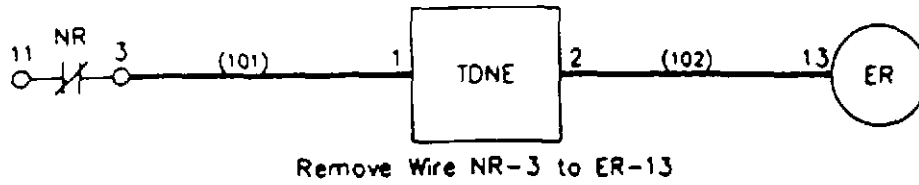

Option 2 (TDES) Time Delay Engine Start

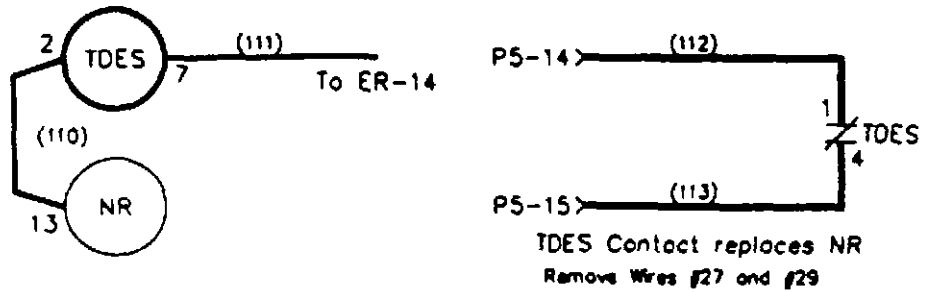

Option 3 (TDEN) Time Delay Emergency to Normal

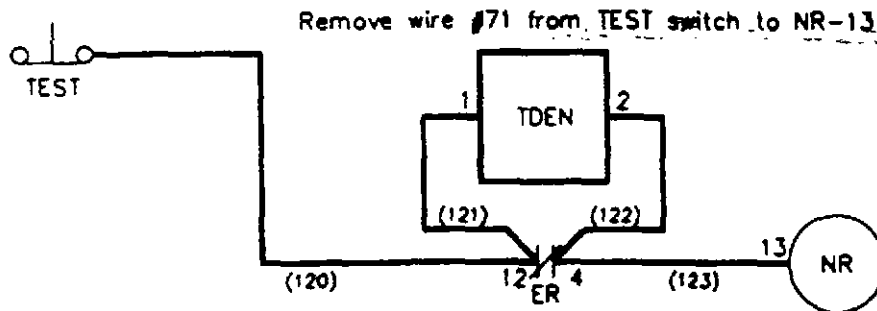

Option 4 (TDEC) Time Delay Engine Cooloff

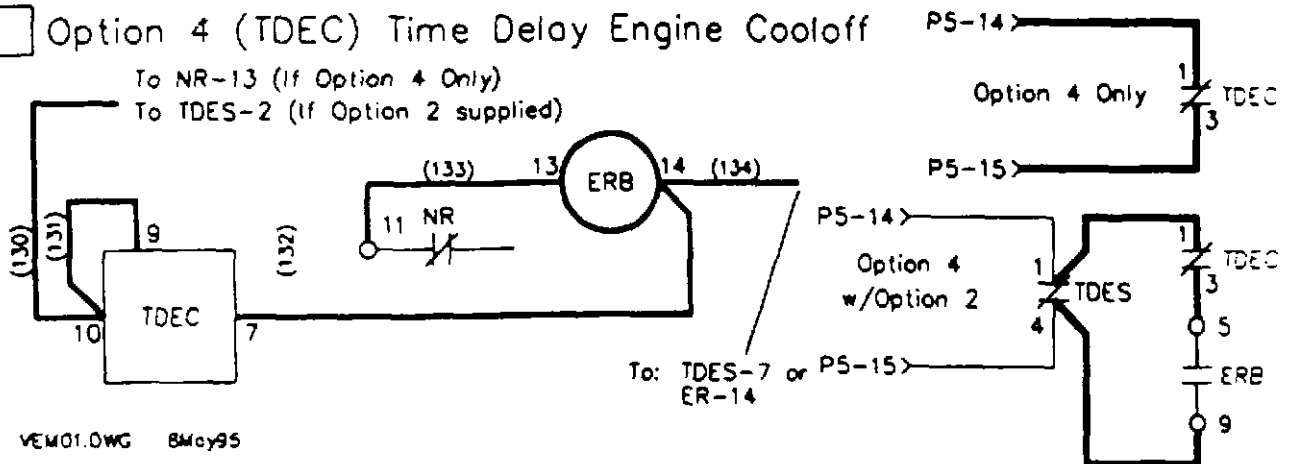

Option 5B Voltage/Frequency Sensing on Emergency

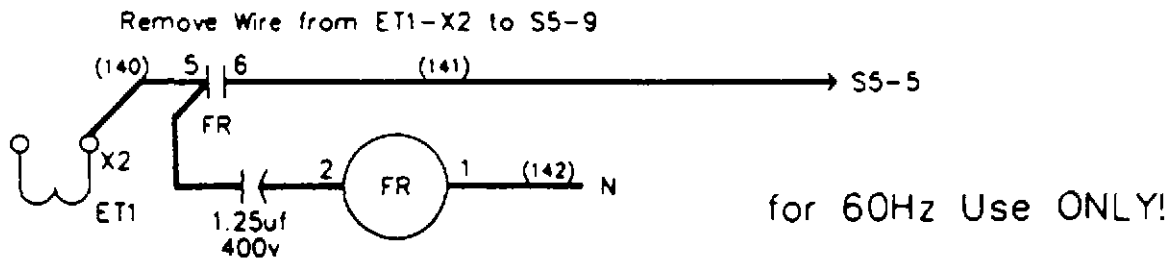

Option 6H (FPSS) Four Position Test Switch

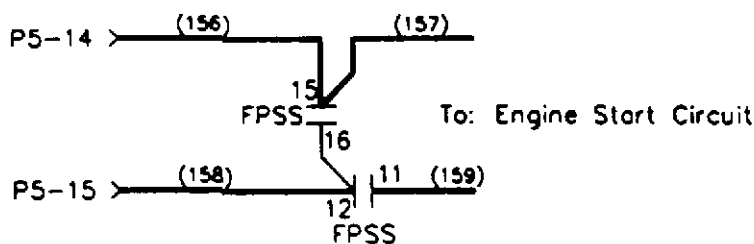
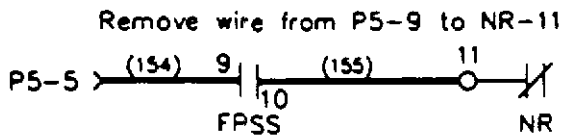
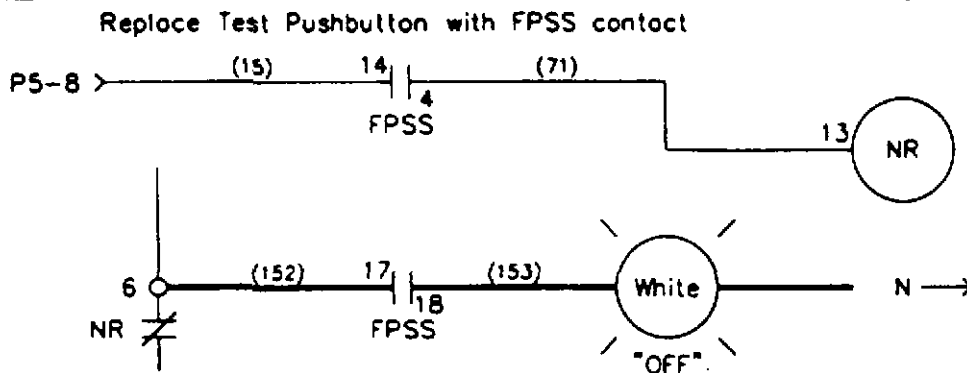

	9 10	11 12	4 14	15 16	17 18
TEST	X	X			
AUTO	X	X	X		
OFF					X
ENG. RUN	X		X	X	

Option 8C (PBEN) Bypass TDEN Timer

Remove wire from P5-9 to NR-11

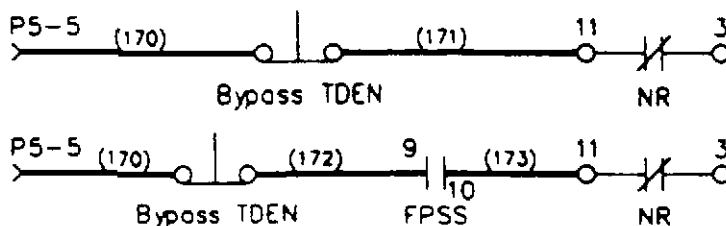

Option 8 with/Option 6H

Option 9 Maintenance Selector Switch

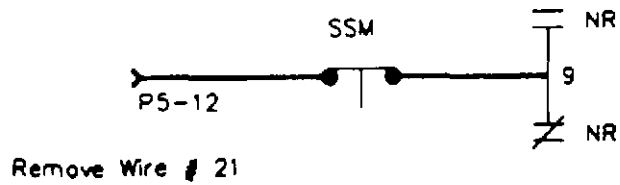

Option 12C Normal Position Light

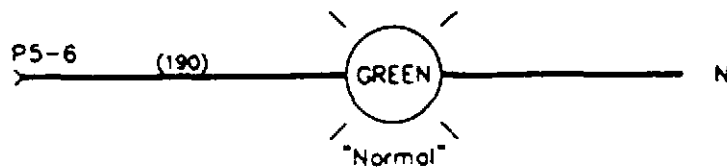

Option 12D Emergency Position Light

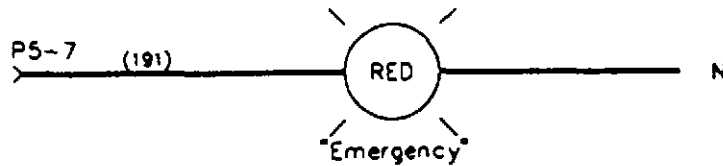

Option 12G Normal Source Light

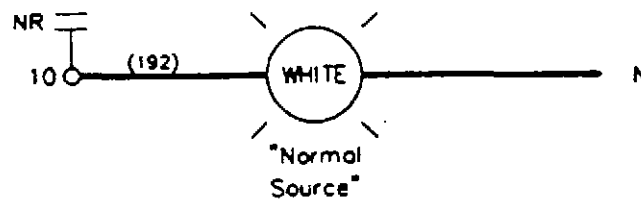

Option 12H Emergency Source Light

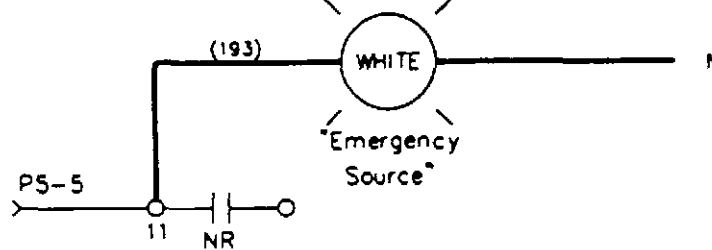

Option 12L Normal Tripped Indicator

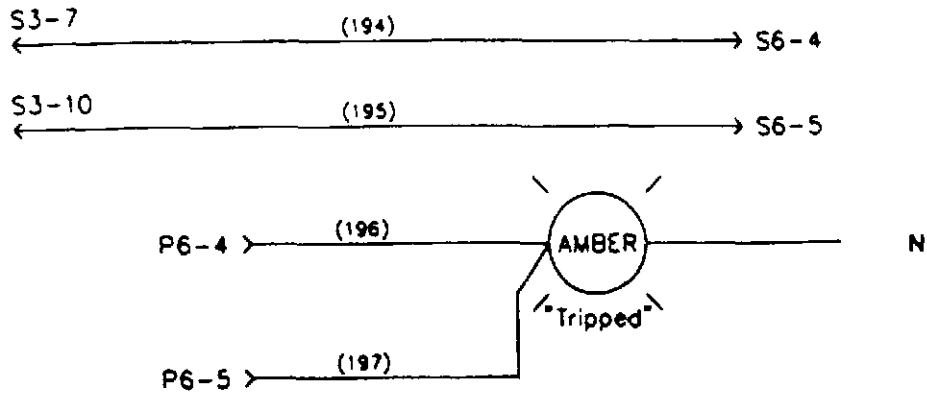

Option 14C Normal Auxiliary Relay

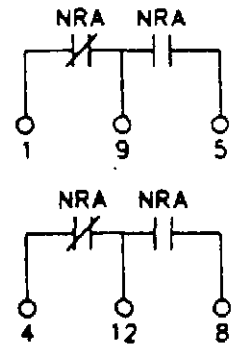
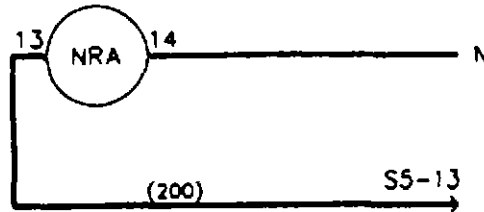

Option 14D Emergency Auxiliary Relay

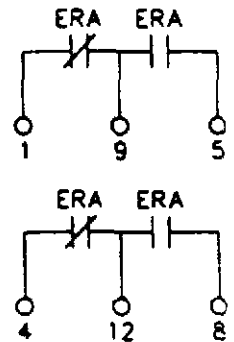

Option 16 Thermal MAgnetic Trips

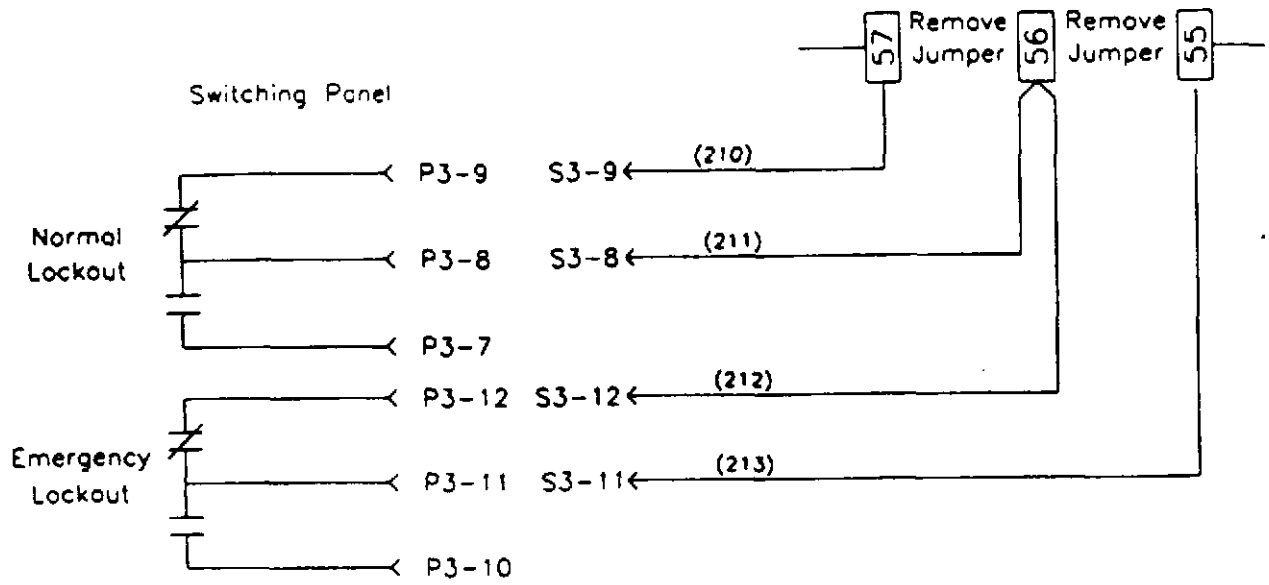

Option 23C Plant Exerciser

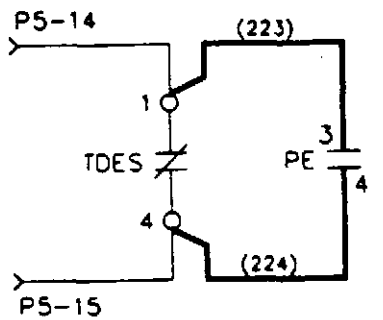
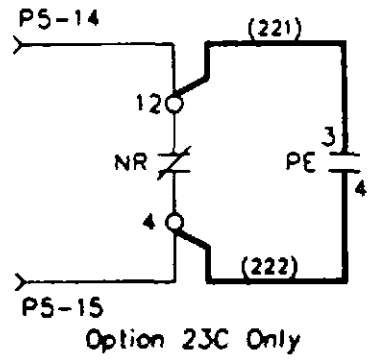
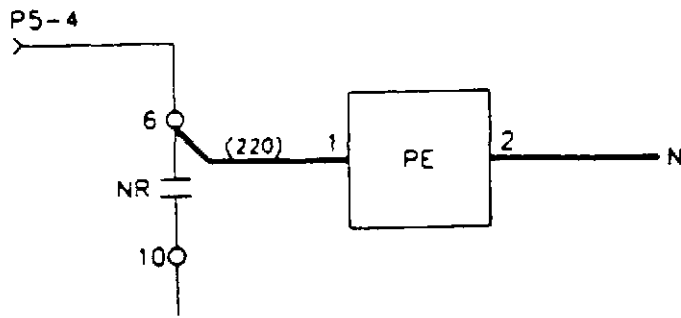

Option 23C w/Option 2 or  
Option 2 and 4

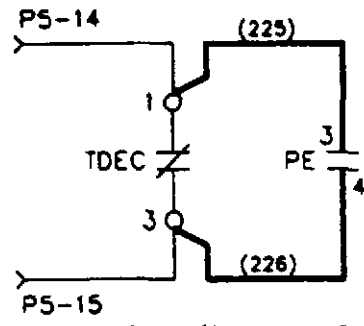

Option 23C w/Option 4 Only

Option 23D Plant Exerciser

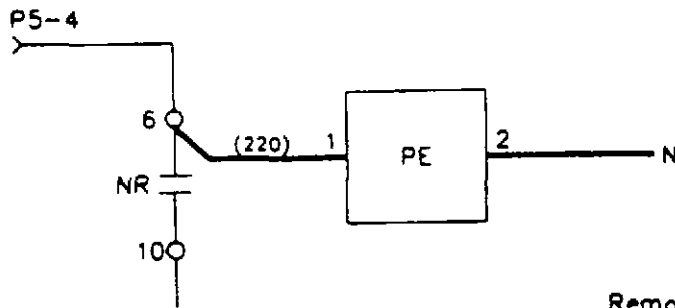

Remove Wire from Test PB to NR-13

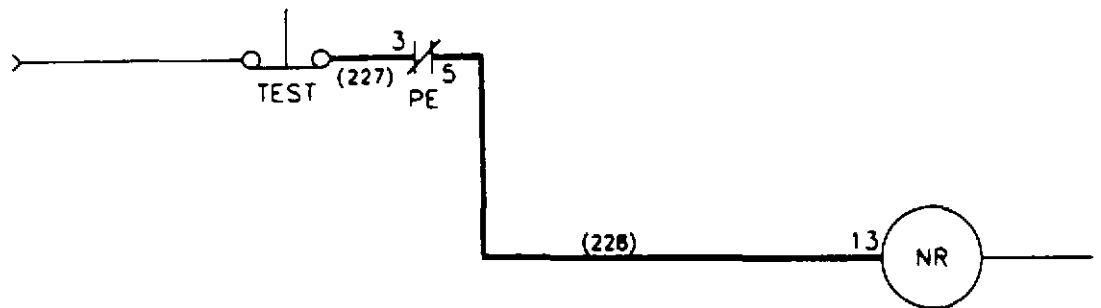

Option 23G Plant Exerciser

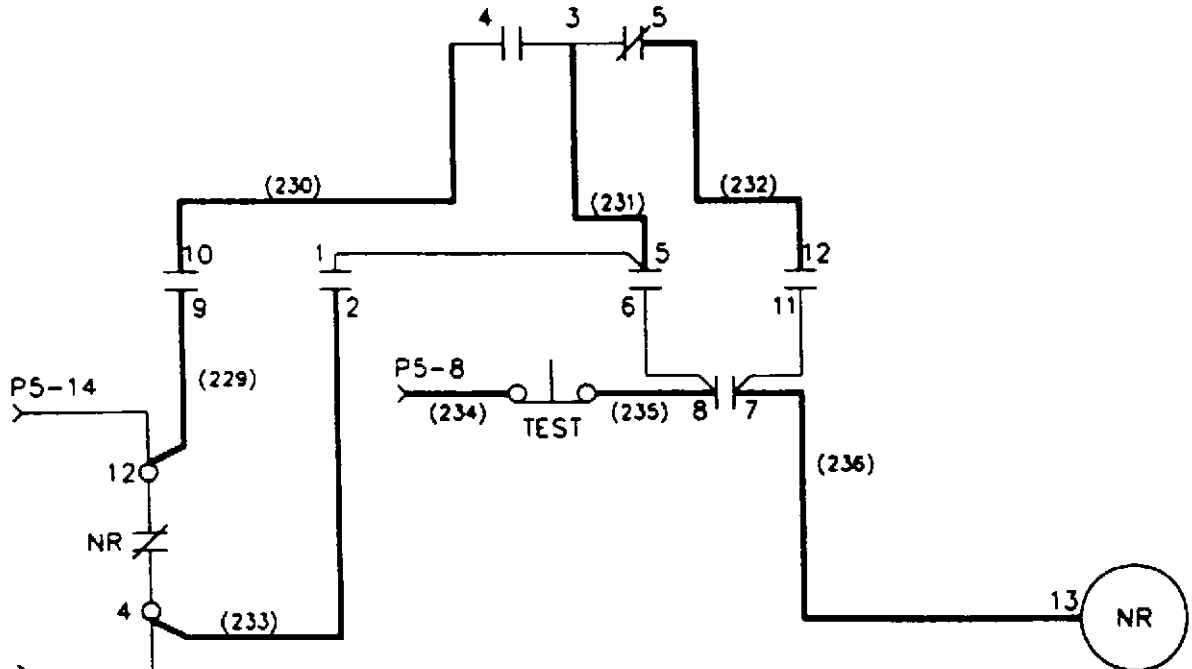
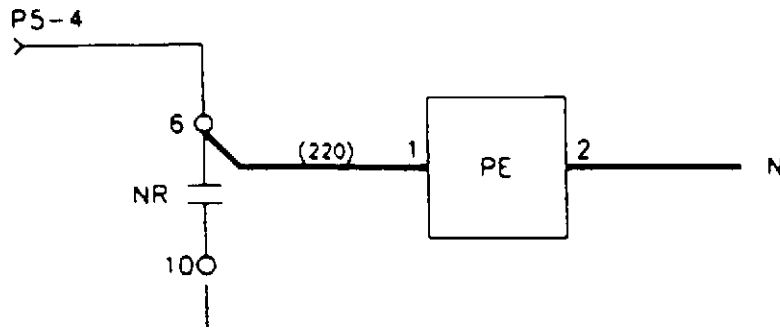

Remove Wire from TEST PB to NR-13

Option 23G Only

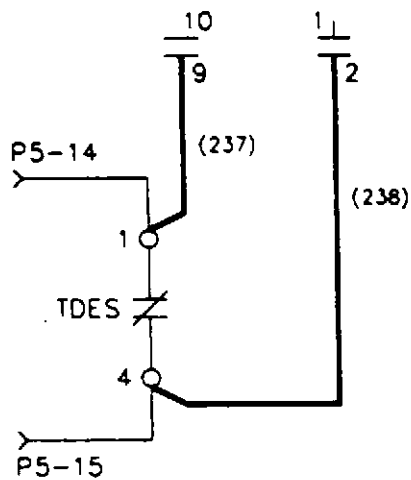

Option 23G w/Option 2 or  
Option 2 and 4

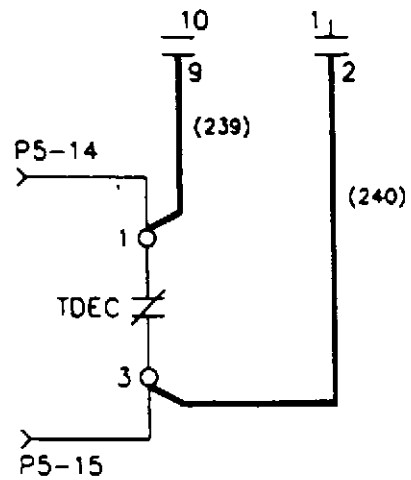

Option 23G w/Option 4 Only

Option 29E Manual Return to Normal

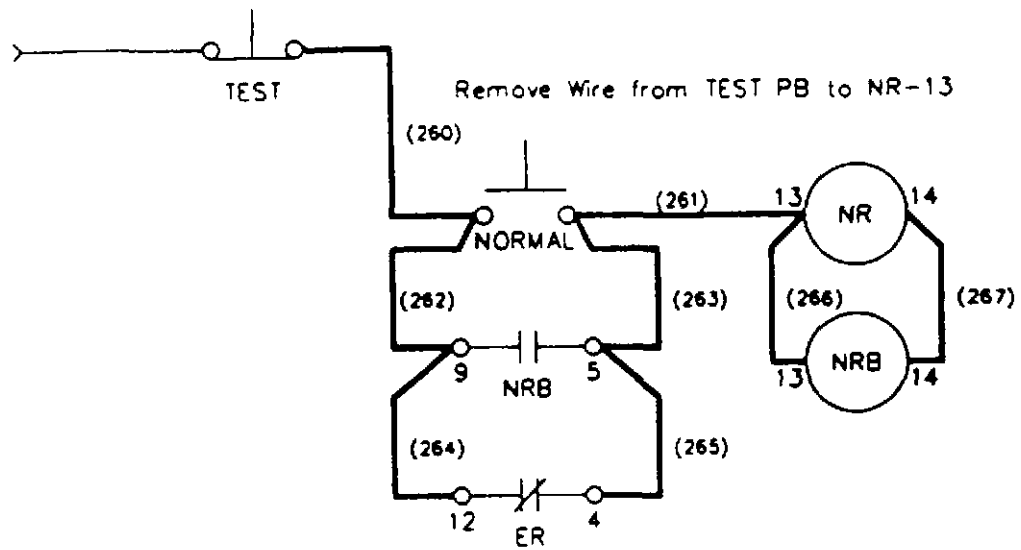

Option 29J Auto/Manual Return to Normal

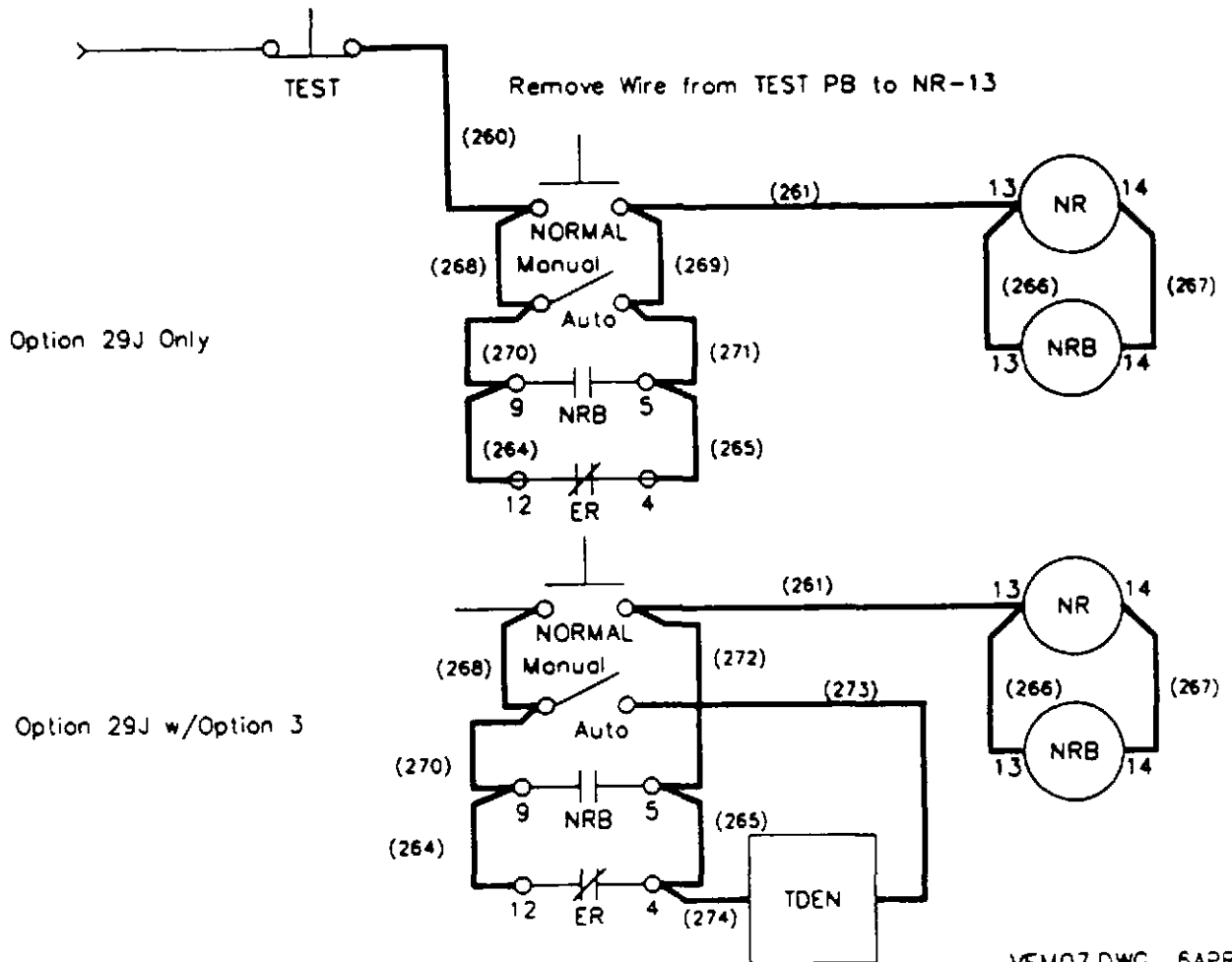

Option 32 Time Delay Neutral

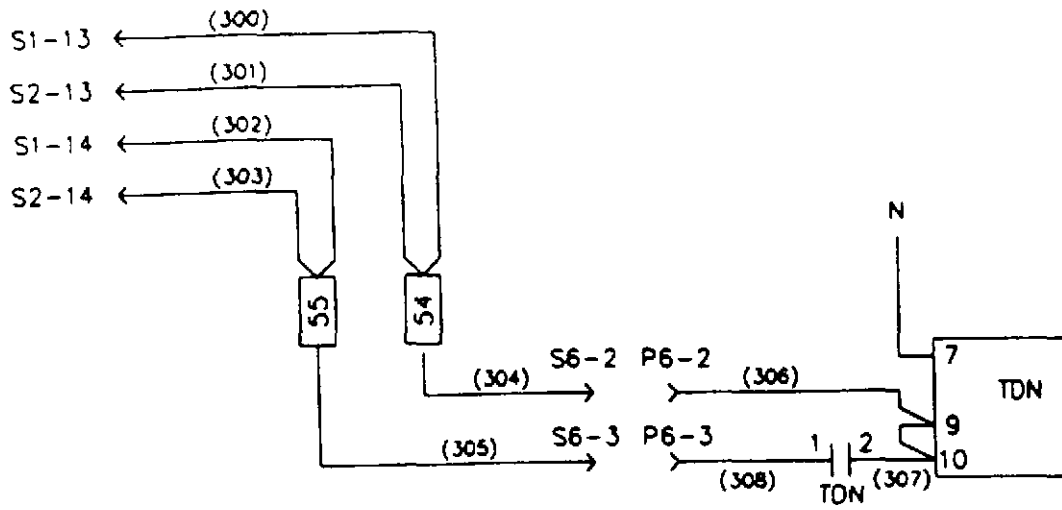

Remove Jumper between 54 and 55





**Cutler-Hammer  
Beaver, PA**

**Automatic Transfer Switch**

**Type ATVSSP Wiring Diagrams**

**Cutler-Hammer  
Power Distribution Components Division  
One Tuscarawas Road  
Beaver, PA 15009**

**Copyright 1995 by Eaton/Cutler-Hammer Inc.  
All Rights Reserved**

**Version 1.2 10-9-92**

# Cutler-Hammer Automatic Transfer Switch Wiring Diagrams

## Directions for Use

The drawing package can be used as a point to point wiring diagram for maintenance and diagnostic purposes for Solid State Logic SPB Transfer Switches, all voltages.

This document contains the following wiring information:

### **Page 1**

Basic Solid State Intelligence Panel Wiring exclusive of added option functions

### **Page 2**

Power Switching Panel basic wiring exclusive of added option functions.

### **Pages 3 - 18**

Wiring for optional functions

### **Page 19**

Legend Sheet describing symbols used throughout this document

Note: Unnumbered sheets may be added to this document on specific occasions to illustrate custom options additions per order instructions.

All transfer switch units will be standardly wired as indicated by Pages 1, and 2. The Intelligence Panel and Power Panel are interconnected via keyed plug/socket connectors (P1-S1/P2-S2). Your specific unit may be equipped with certain optional functions as noted which require additional wiring as shown on pages 3 - 18.

Wiring for optionally added functions will typically interface with the basic unit wiring (Pages 1-2) which should be used as the base reference.

Note: **BOLD** lines on option wiring indicate components and wiring added to the basic wiring diagram to accomplish that specific option function.

# Cutler-Hammer Automatic Transfer Switch

## Standard Features

### **Test Pushbutton**

Simulates a power failure in the logic. Will cause the Generator to start, and load to transfer to the Emergency Source.

### **Undervoltage Protection on NORMAL (All phases)**

Monitors the voltage on the NORMAL Source for an undervoltage condition. Should the voltage drop below a preset Dropout, the generator is started and transfer to the EMERGENCY Source takes place.

### **Engine Start Contact**

Contact that provides a closure to Engine Controller when the NORMAL Source fails.

### **Logic Disconnect**

Plugs provided to disconnect the logic circuitry for maintenance purposes.

### **Auxiliary Contacts**

Auxiliary contacts integral to the switching devices rated at 120 VAC, 10 amps. These may be applied for customer use, and may be applied to certain customer specified options.

### **Fully Rated Neutral**

A fully rated solid neutral is supplied on all two and three pole switches. All four pole switches are supplied with switched neutral contacts of identical construction and rating as the power poles.

# SPB ATS INTELLIGENCE PANEL

NOTE A

NOTE A:  
 TRANSFORMERS NT3, NT4 AND  
 WIRES 183, 188 USED FOR  
 3 PHASE NORMAL SENSING  
 TRANSFORMERS ET3, ET4 AND  
 WIRES 114, 116 USED FOR  
 3 PHASE EMERGENCY SENSING  
 (OPTION SF AND/OR SC)

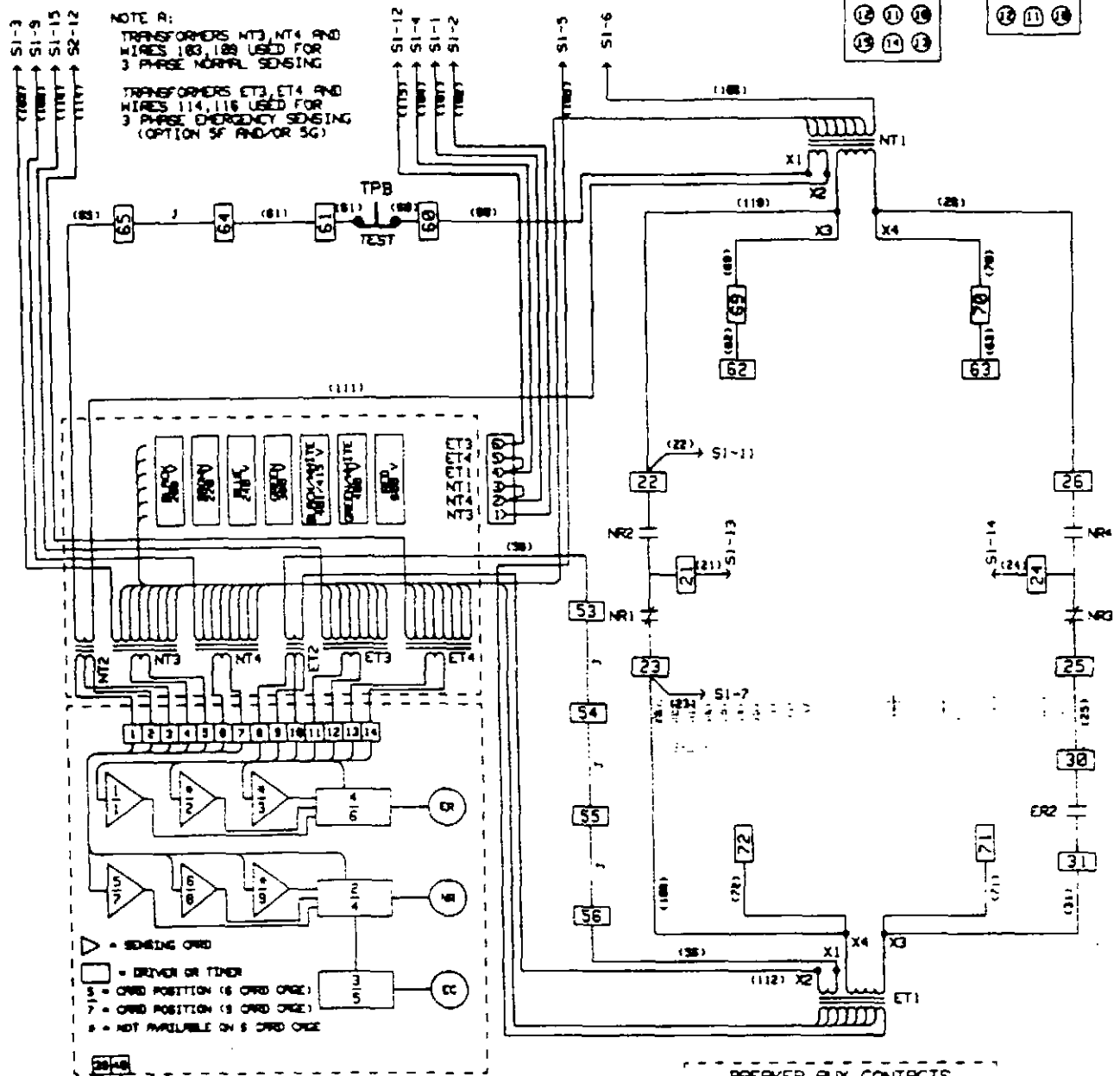
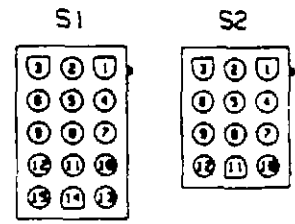

- ▽ SENSING CRD
- DRIVER OR TIMER
- 15 CRD POSITION (S CRD CRG)
- 7 CRD POSITION (S CRD CRG)
- NOT AVAILABLE ON S CRD CRG

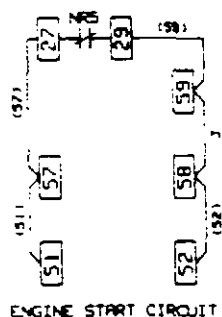

ENGINE START CIRCUIT

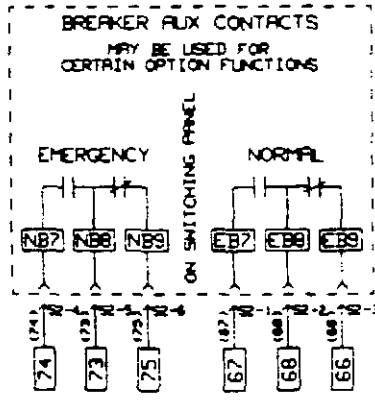

# SPB POWER SWITCHING PANEL (FIXED MOUNT)

PAGE 1

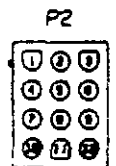
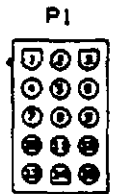
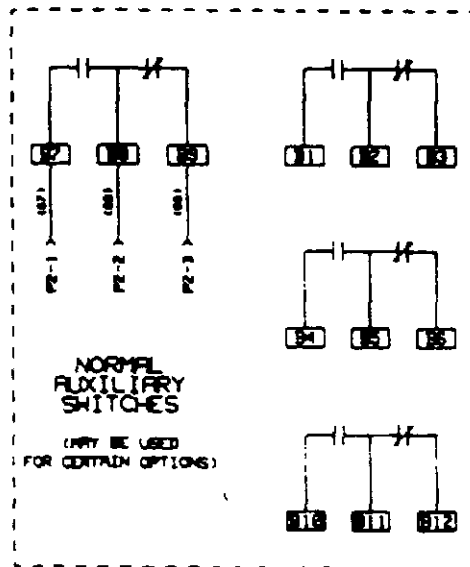
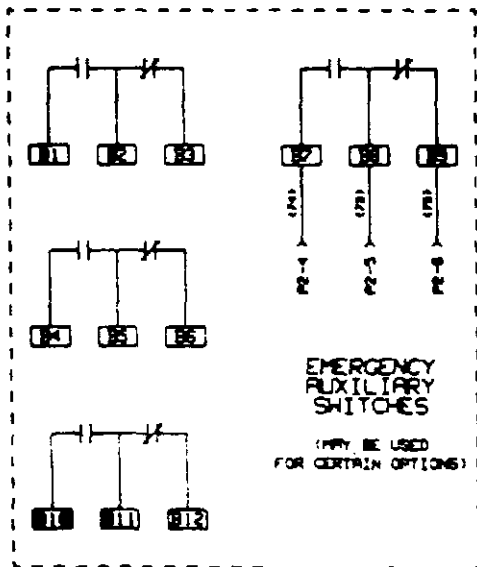
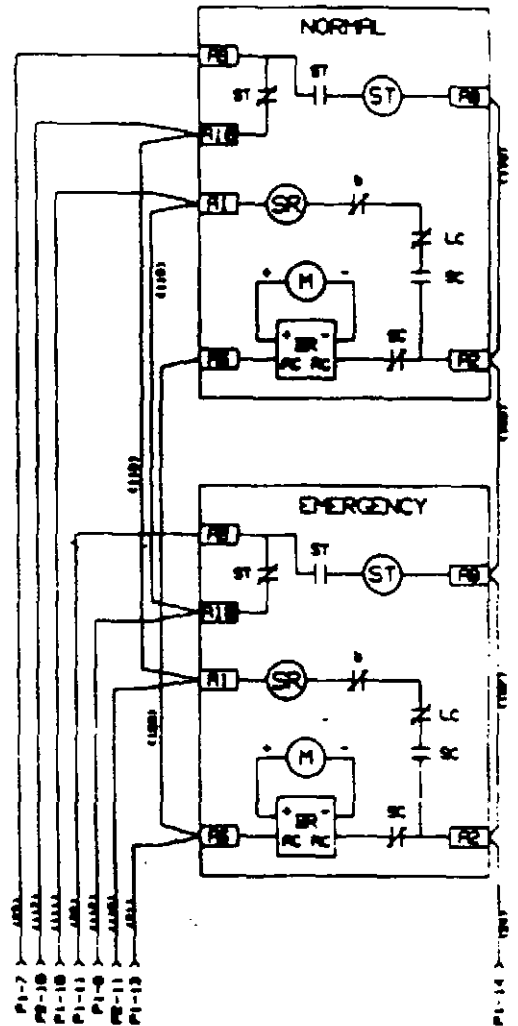
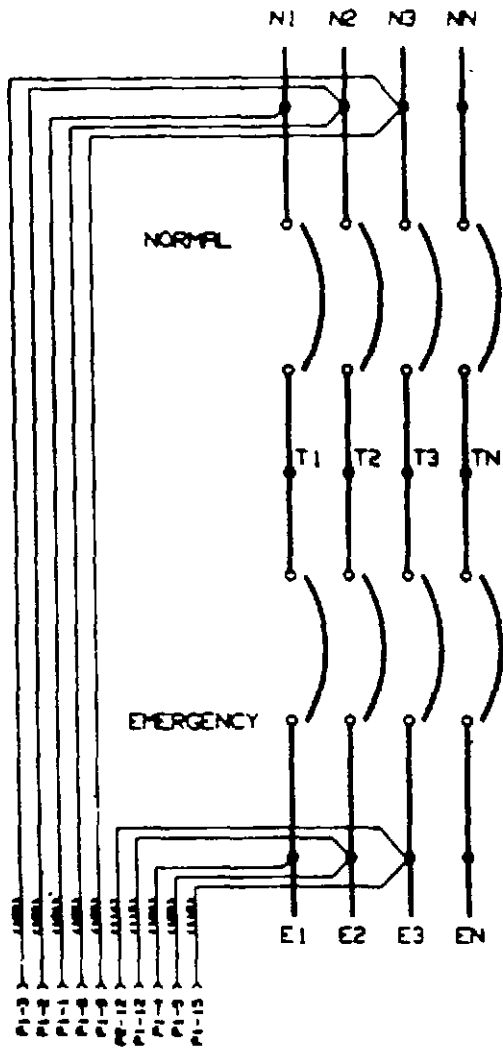

6 POSITION CARD CAGE

NORMAL		ENG	EMERGENCY		
1	2	3	4	5	6
UNDERVOLTAGE	STD	DRIVER (OPTION 3)	BLANK (OPTION 4)	DRIVER (OPTION 1)	BLANK (OPTION 5)
					BLANK (OPTION 5)

9 POSITION CARD CAGE

NORMAL			ENG	EMERGENCY					
1	2	3	4	5	6	7	8	9	
UNDERVOLTAGE	STD	BLANK (OPTION 26)	BLANK (OPTION 26)	DRIVER (OPTION 3)	BLANK (OPTION 4)	DRIVER (OPTION 1)	BLANK (OPTION 5)	BLANK (OPTION 5)	BLANK (OPTION 5)

OPTION 1 - TIME DELAY NORMAL TO EMERGENCY (TDNE)

6 POSITION CARD CAGE  
REPLACE DRIVER CARD IN POSITION 4  
WITH TIMER CARD

9 POSITION CARD CAGE  
REPLACE DRIVER CARD IN POSITION 6  
WITH TIMER CARD

OPTION 3 - TIME DELAY EMERGENCY TO NORMAL (TDEN)

6 POSITION CARD CAGE  
REPLACE DRIVER CARD IN POSITION 2  
WITH TIMER CARD

9 POSITION CARD CAGE  
REPLACE DRIVER CARD IN POSITION 4  
WITH TIMER CARD

OPTION 4 - TIME DELAY ENGINE COOLOFF (TDEC)

6 POSITION CARD CAGE  
REPLACE BLANK CARD IN POSITION 3  
WITH TIMER CARD  
ADD EC RELAY TO MOTHERBOARD

9 POSITION CARD CAGE  
REPLACE BLANK CARD IN POSITION 5  
WITH TIMER CARD  
ADD EC RELAY TO MOTHERBOARD

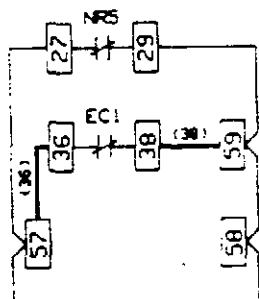

OPTION 4 ONLY

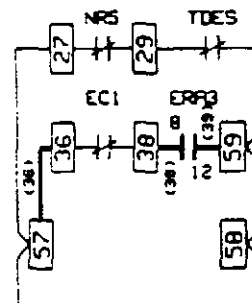

OPTION 4 WITH 2 \*\*  
\*\* REQUIRES OPTION 14D

OPTION 5 - EMERGENCY SENSING (UV,OV,UF,OF)

6 POSITION CARD CAGE  
REPLACE BLANK CARD IN POSITION 5 OR 6  
WITH APPROPRIATE SENSING CARD

9 POSITION CARD CAGE  
REPLACE BLANK CARD IN POSITION 7,8 OR 9  
WITH APPROPRIATE SENSING CARD

OPTION 25 - NORMAL SENSING (OV,UF,OF)

6 POSITION CARD CAGE  
NOT AVAILABLE

9 POSITION CARD CAGE  
REPLACE BLANK CARD IN POSITION 2 OR 3  
WITH APPROPRIATE SENSING CARD

\* UNDERVOLTAGE SENSING ON NORMAL IS STANDARD

OPTION 2 - TIME DELAY ENGINE START (TDES)

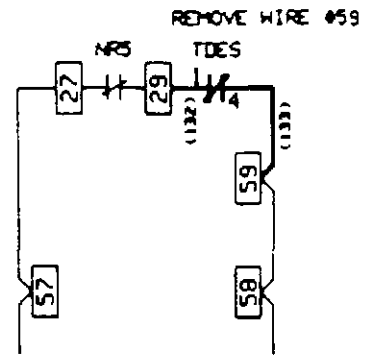
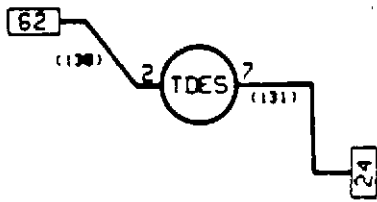

OPTION 6D - TEST SELECTOR (TSS)

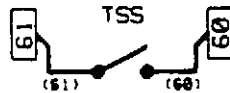

REPLACES STANDARD TEST PUSHBUTTON

OPTION 6H - FOUR POSITION SELECTOR SWITCH (FPSS)

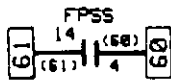

REPLACES STANDARD TEST SELECTOR SWITCH

FPSS	1-9 10T	1-11 12T	1-14 14T	1-15 16T	1-17 18T
TEST					
AUTO	X	X	X	X	X
OFF					
ENG. RUN	X	X	X	X	X

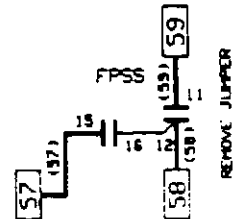
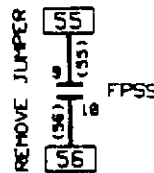
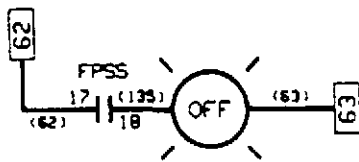

OPTION 8C - BYPASS TDEN TIMER (PBEN)

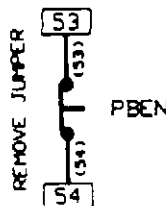

OPTION 8D - BYPASS TDNE TIMER (PBNE)

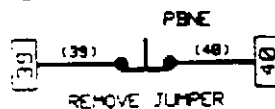



- OPTION 12C - NORMAL POSITION LIGHT (NL)  
INDICATES LOAD IS CONNECTED TO NORMAL

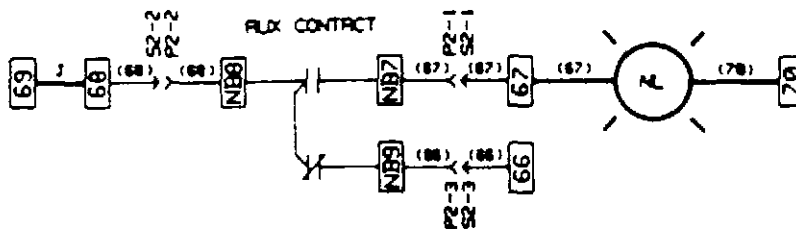

- OPTION 12D - EMERGENCY POSITION LIGHT (EL)  
INDICATES LOAD IS CONNECTED TO EMERGENCY

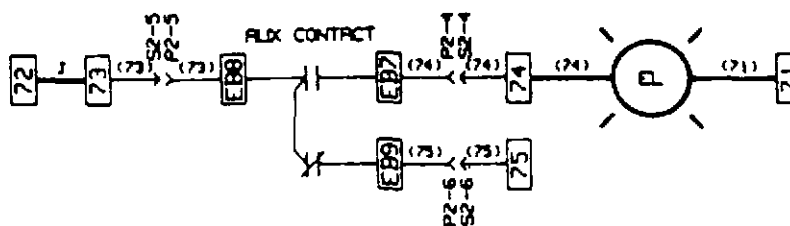

- OPTION 12G - NORMAL SOURCE LIGHT (SN)  
INDICATES NORMAL SOURCE AVAILABLE

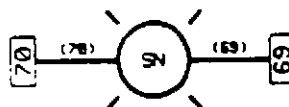

- OPTION 12H - EMERGENCY SOURCE LIGHT (SE)  
INDICATES EMERGENCY SOURCE AVAILABLE

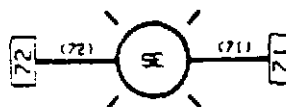



OPTION 14C - NORMAL AUXILIARY RELAY (NRA)  
 PROVIDES ADDITIONAL RELAY CONTACTS ON NORMAL

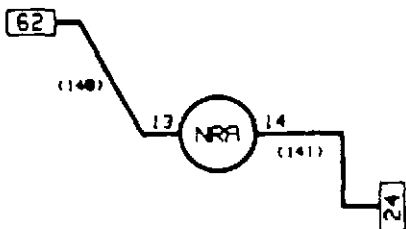

NOTE: CUSTOMER CONTACTS ARE ON RELAY SOCKET  
 SEE SOCKET DIAGRAM BELOW

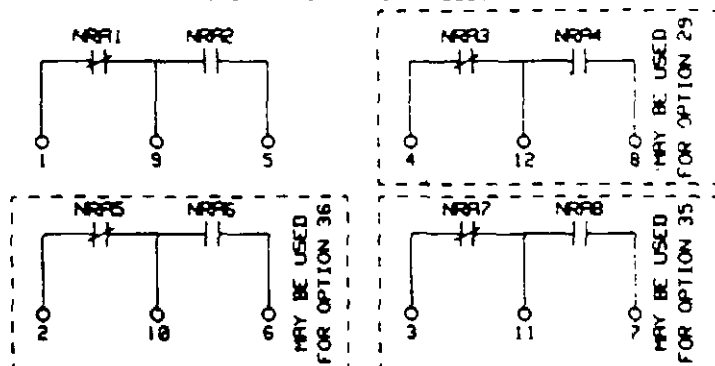

OPTION 14D - EMERGENCY AUXILIARY RELAY (ERA)  
 PROVIDES ADDITIONAL RELAY CONTACTS ON EMERGENCY



NOTE: CUSTOMER CONTACTS ARE ON RELAY SOCKET  
 SEE SOCKET DIAGRAM BELOW

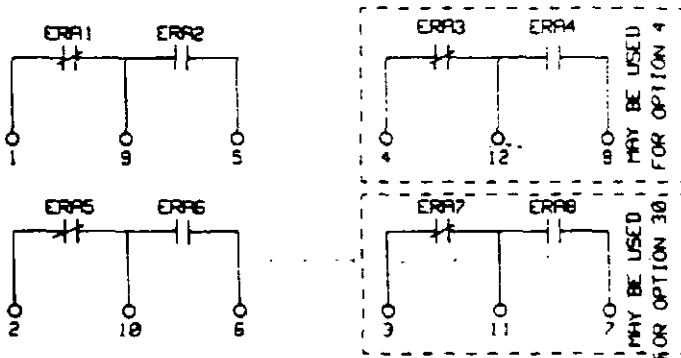

NRA - ERA SOCKET DIAGRAM

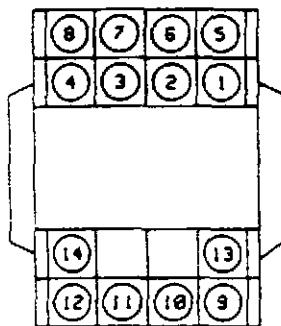

OPTION 18E - VOLTMETER

	HANDLE POSITION					
	NORMAL			EMERGENCY		
	1-3	2-3	1-2	1-2	2-3	1-3
1 — 2				X		X
3 — 4	X		X			
5 — 6					X	X
7 — 8		X				
9 — 10						X
11 — 12	X					
13 — 14				X	X	
15 — 16		X	X			

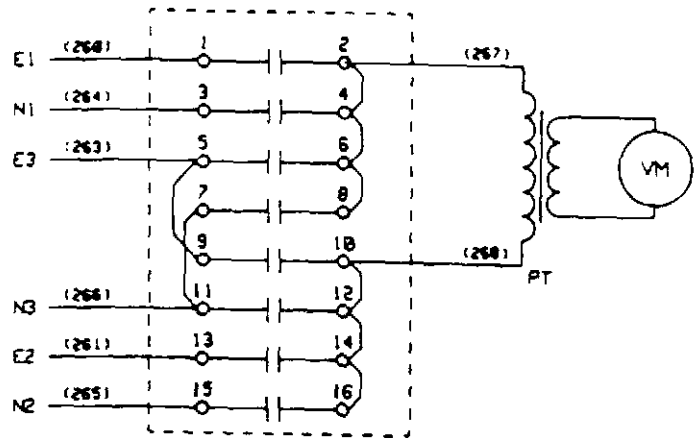

OPTION 18F - AMMETER

	HANDLE POSITION					
	OFF	1	2	3		
1 — 2	X	X	X	X	X	X
3 — 4	X	X	X	X	X	X
5 — 6	X	X	X	X	X	X
7 — 8	X	X	X	X	X	X
9 — 10	X	X	X	X	X	X
11 — 12	X	X	X	X	X	X

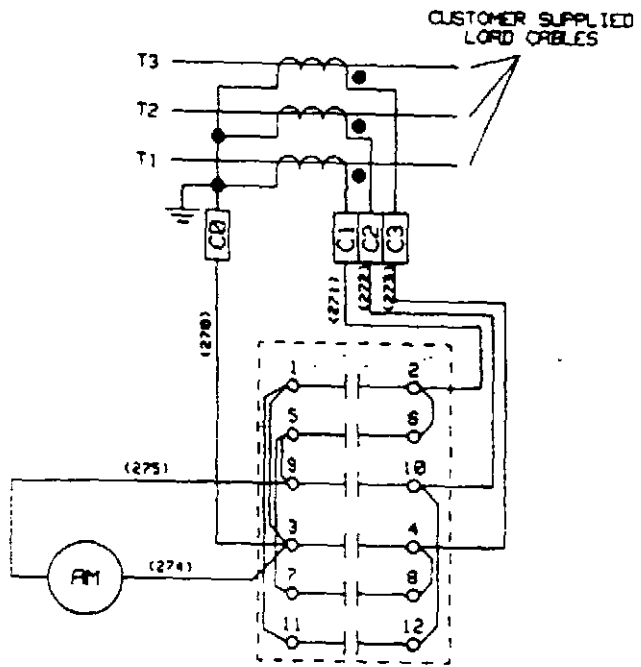

OPTION 18G - FREQUENCY METER

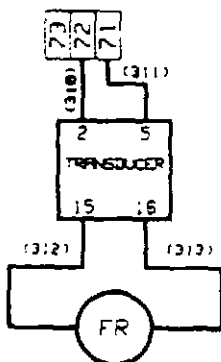

OPTION 18H - RUNNING TIME METER

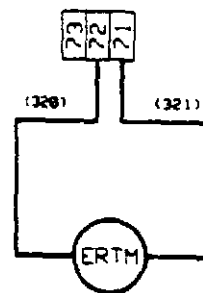

OPTION 23C - PLANT EXERCISER  
 RUN ENGINE AT SPECIFIED TIME  
 (NO LOAD)

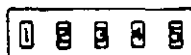
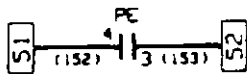

PE TERMINAL BLOCK

OPTION 23I = 23D W/FAILSAFE  
 OPTION 23J = 23G W/FAILSAFE

OPTION 23D - PLANT EXERCISER  
 RUN ENGINE AT SPECIFIED TIME  
 (LOAD)

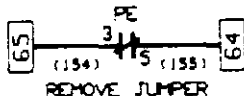

FAILSAFE CIRCUIT

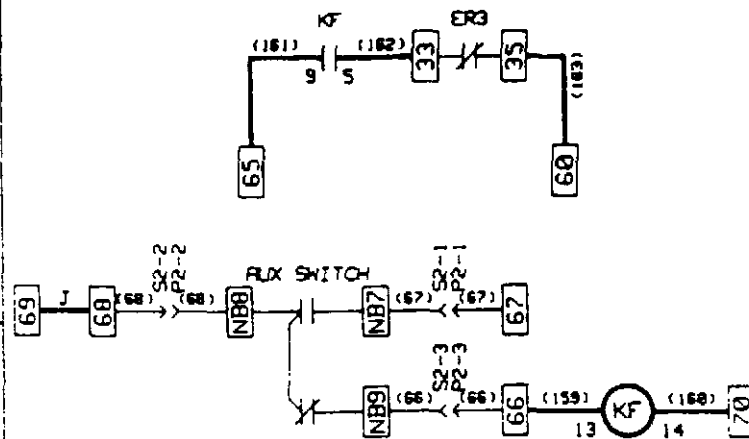

OPTION 23G - PLANT EXERCISER  
 RUN ENGINE AT SPECIFIED TIME  
 (SWITCH SELECTABLE  
 LOAD OR NO LOAD)

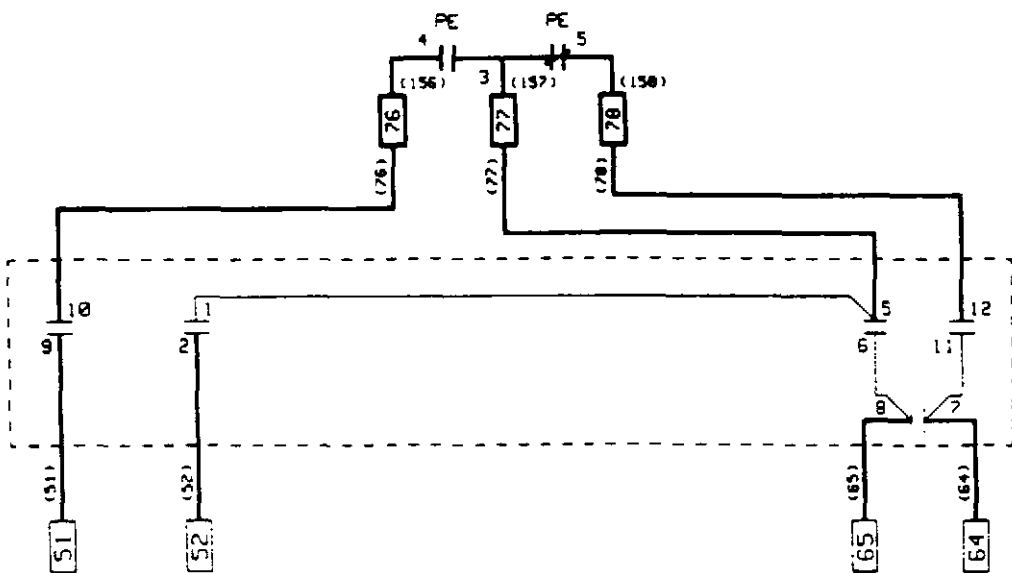

REMOVE JUMPER 64-65

	ENGINE RUN	BYPASS	LORD TEST
1   2	X		
5   6			X
7   8	X	X	
9   10	X		
11   12			X

OPTION 28A - INTELLIGENCE CIRCUIT FUSES  
FUSES NON-ESSENTIAL CIRCUITRY ONLY

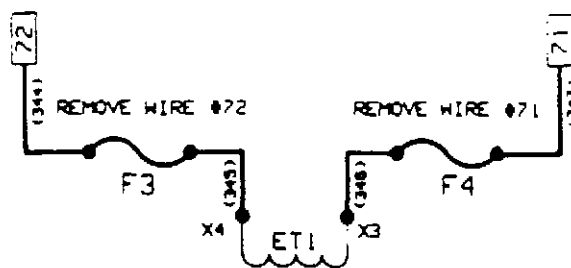
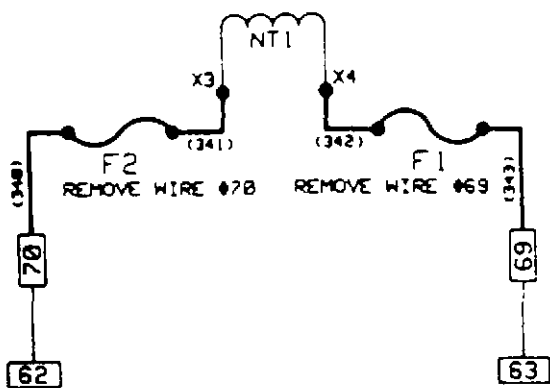

OPTION 30 - TIME DELAY CRANK LIMITER (TDCL)  
INTERUPTS ENGINE START CIRCUIT IF VOLTAGE DOES NOT APPEAR WITHIN A PRESELECTED TIME

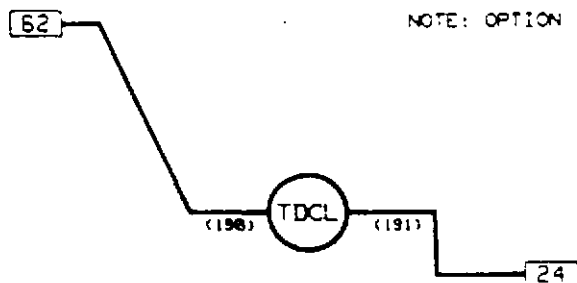

NOTE: OPTION 14d REQUIRED

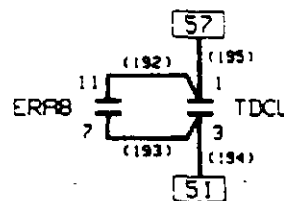

OPTION 31B - AUDIBLE ALARM W/SILENCE SWITCH  
ALARM WHEN ATS IS CONNECTED TO EMERGENCY

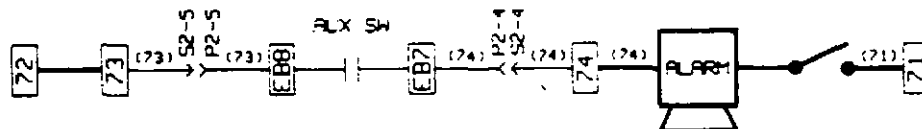

OPTION 31 ONLY

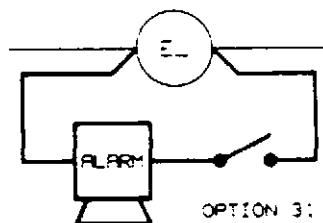

OPTION 31 WITH OPTION 12D

OPTION 29E - MANUAL RETURN TO NORMAL (NMPB)

REQUIRES OPTION 14C  
 OPTION 3 MAY NOT BE USED

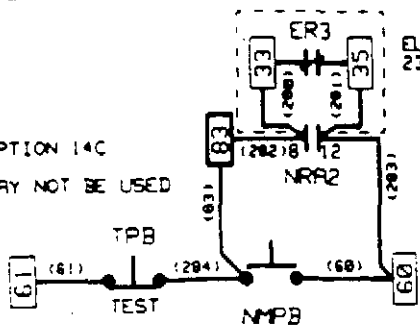

ELIMINATE IF OPTIONS 23I OR 23J ARE USED

OPTION 29J AUTOMATIC/MANUAL RETURN TO NORMAL

REQUIRES OPTION 14C

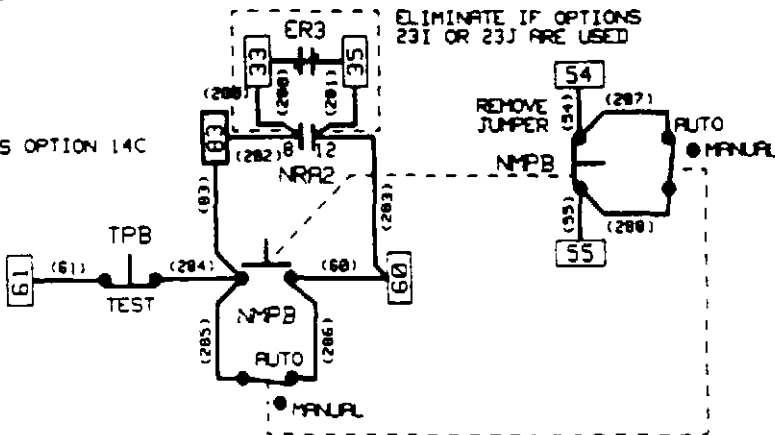

ELIMINATE IF OPTIONS 23I OR 23J ARE USED

OPTION 29G - AUTOMATIC/MANUAL OPERATION

REQUIRES OPTION 14C

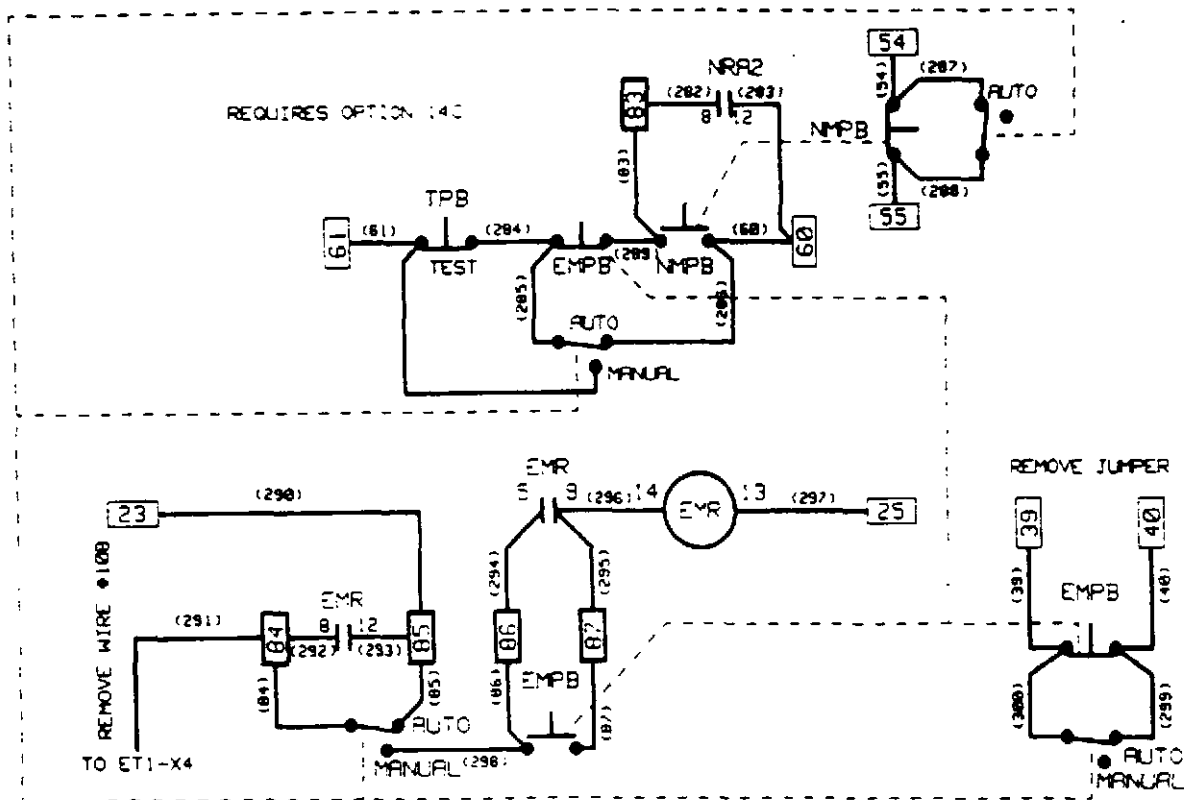



OPTION 32 - TIME DELAY NEUTRAL

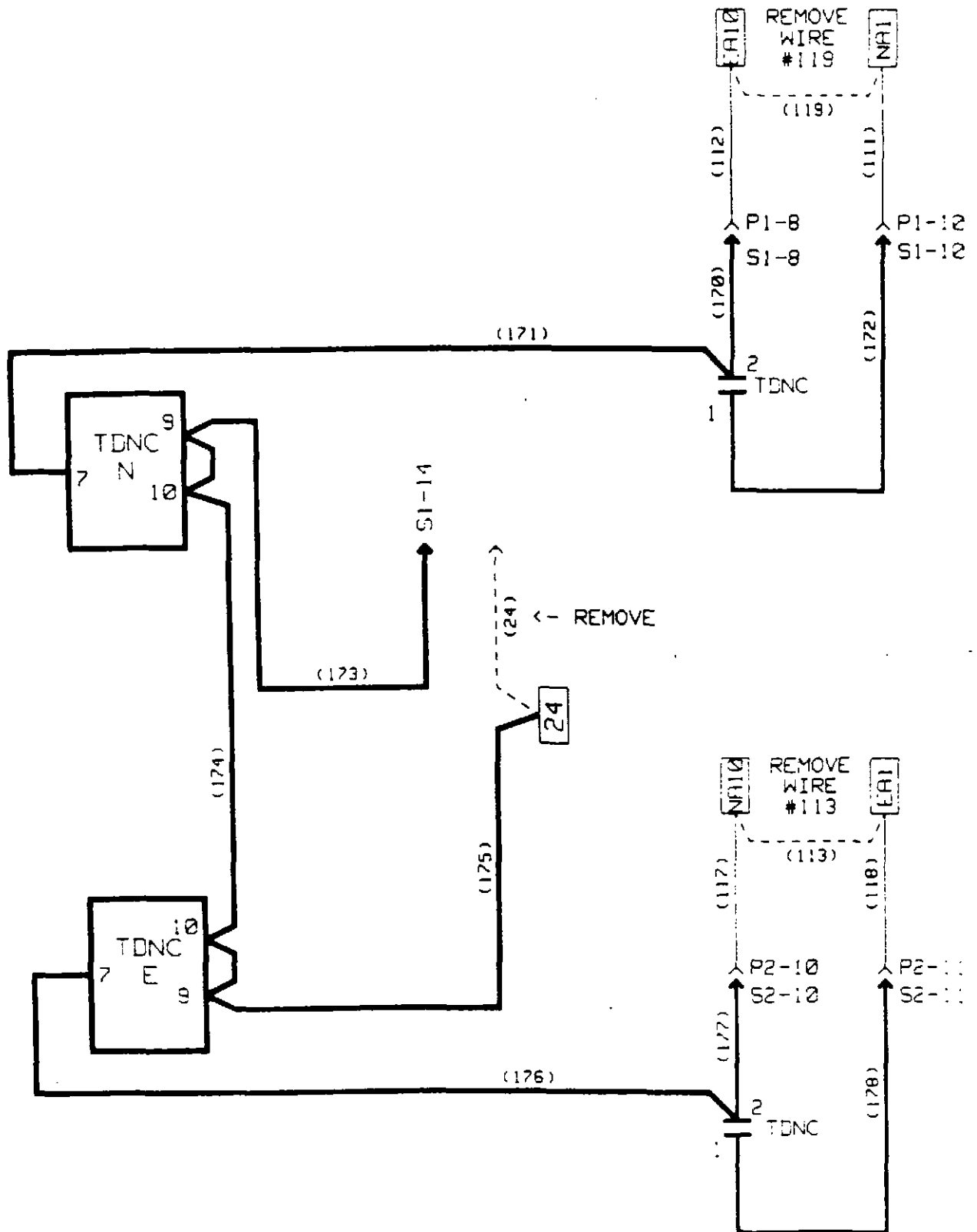



# OPTION 35 - PRETRANSFER SIGNAL DEVICE

(OPTION 14 REQUIRED)

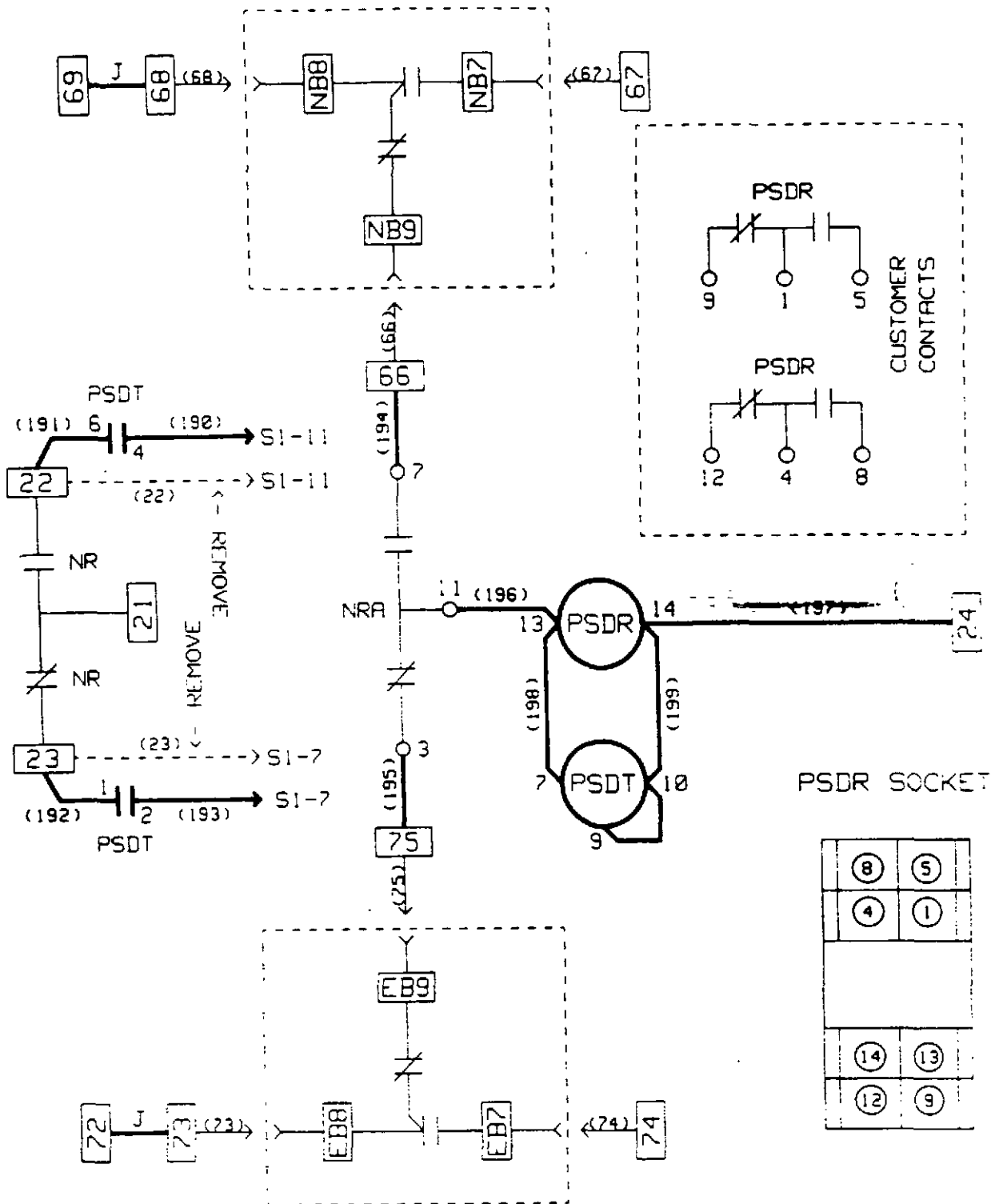

PSDR SOCKET

8	5
4	1
14	13
12	9



# OPTION 36 - LOAD SHED

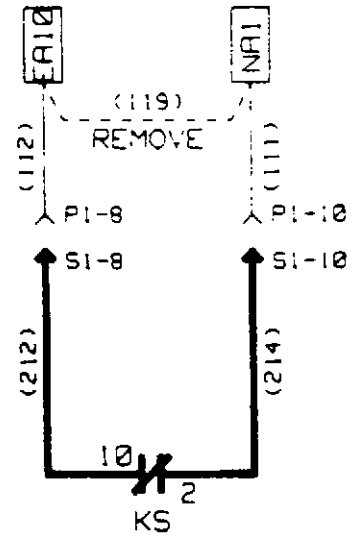
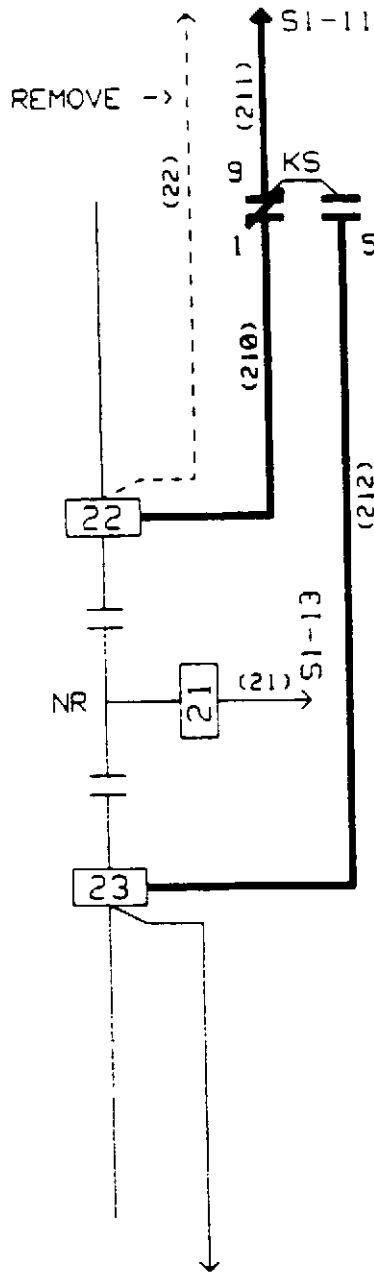

KS RELAY SOCKET

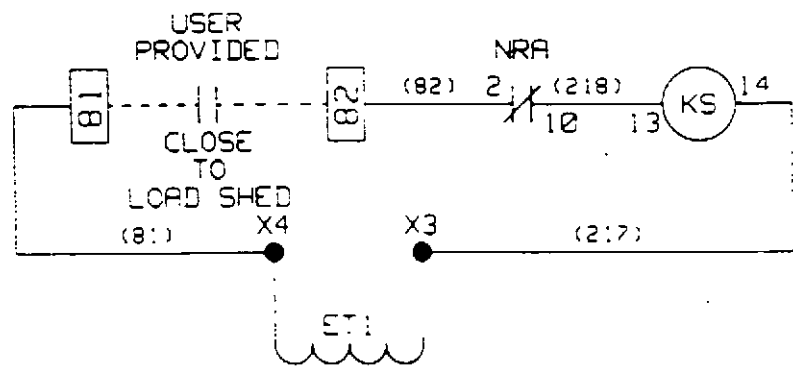
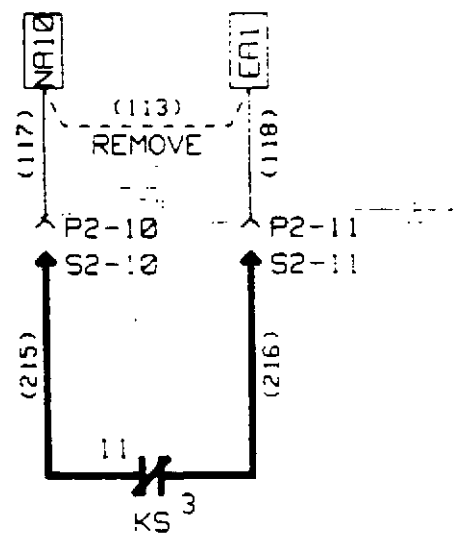
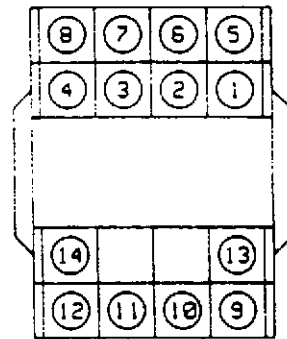

OPTION 37 - SERVICE ENTRANCE  
(MUST USE OPTION 16)

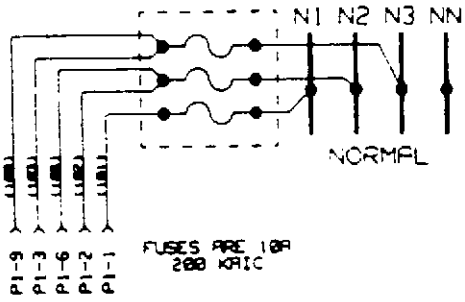

KV IS PROVIDED  
BY OPTION 16

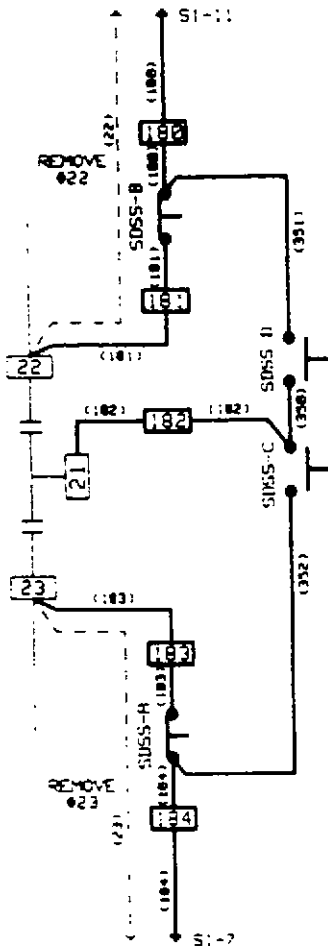
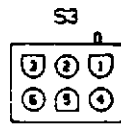
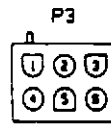
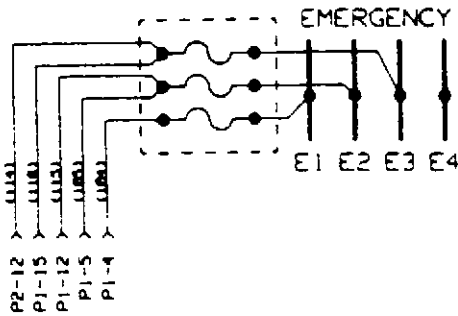
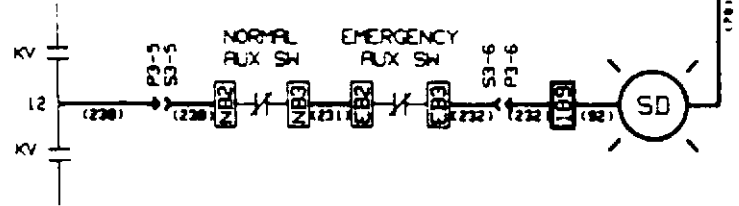

SERVICE DISCONNECT SEL SW	E	B	U	D	W	L
DISCONNECT			X	X		
ENERGIZE	X	X			X	X

KEY LOCKED  
KEY REMOVABLE  
IN "DISCONNECTED" POSITION

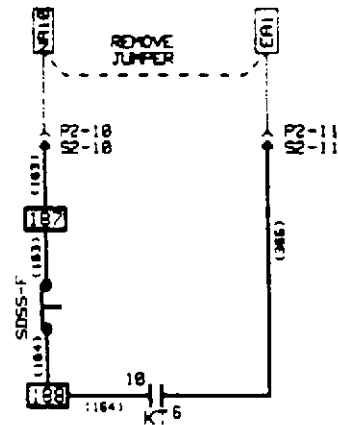
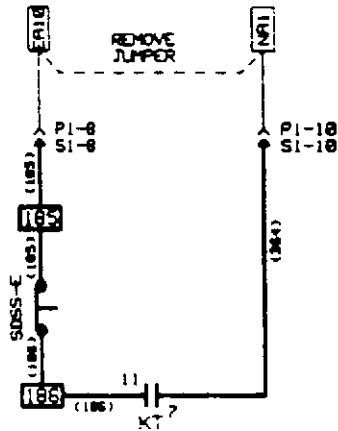

# COMBINATION WIRING

## OPTIONS 16, 32, 35, 36, AND 37

THIS DRAWING SHOWS INTER WIRING OF THESE OPTIONS WHEN COMBINED

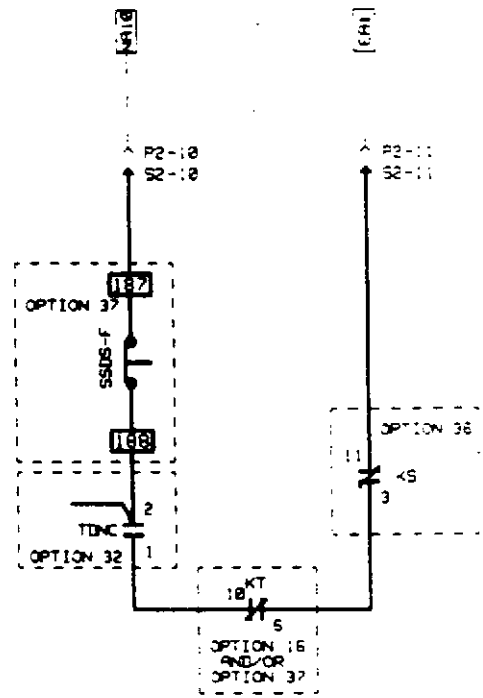
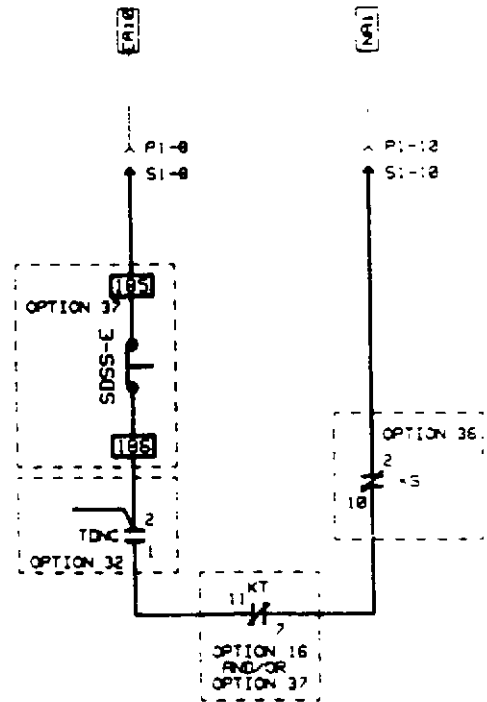
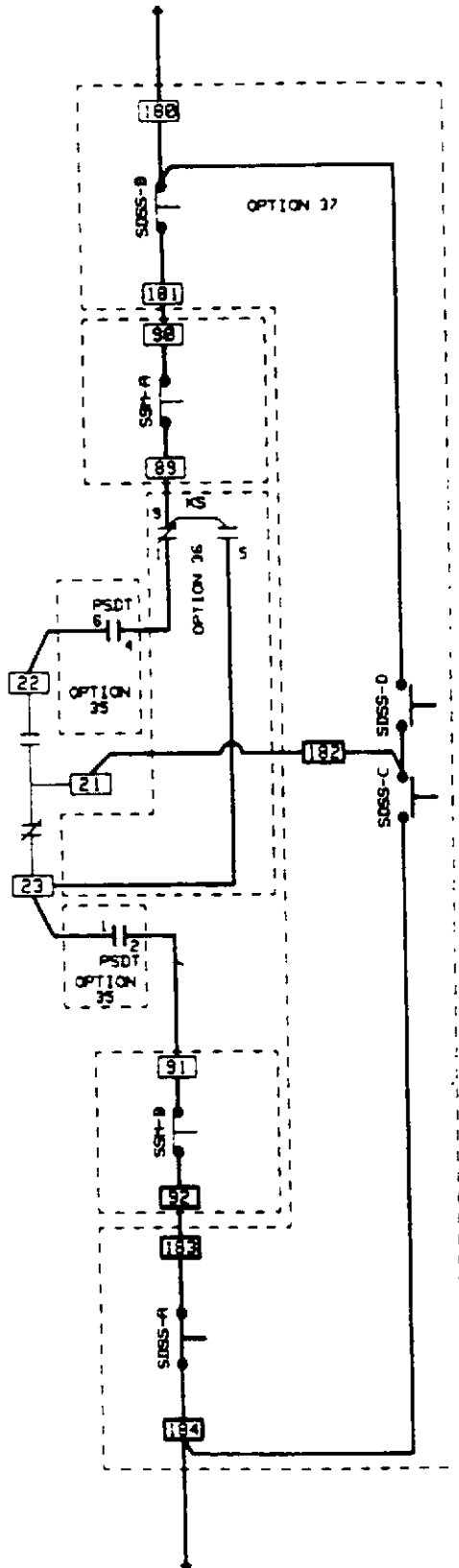



Westinghouse SPB Automatic Transfer Switch  
Legend for Wiring Diagram Symbols

Symbol	Description
AM	Ammeter
Ex	Power Terminal, Emergency Source (x = Terminal Number)
EASx	Emergency Lockout (x = contact number)
EC	Engine Cooloff Relay Coil
ECx	Engine Cooloff Relay Contact (x = contact number)
EL	Emergency Position Indicator Light
EMPB	Emergency Pushbutton for Manual Operation
EMR	Emergency Relay (Manual Operation)
ER	Emergency Relay Coil
ERx	Emergency Relay Contact (x = contact number)
EPA	Emergency Auxiliary Relay Coil
EPAx	Emergency Auxiliary Relay Contact (x = Contact Number)
ERTM	Generator Run Time Meter
ESx	Emergency Auxiliary Switch (x = contact number)
ET1	Emergency Transformer (Line Voltage to 120vac - 2 windings)
ET2	Emergency Transformer (120 to 24vac CT)
ET3	Emergency Transformer (Line Voltage to 12vac)
ET4	Emergency Transformer (Line Voltage to 12vac)
FPSS	Four Position Selector Switch (Option 6H)
FR	Frequency Meter
FX	Fuse (x = Fuse Number)
KR	Failsafe Relay
KS	Load Shed Relay
KT	Trip Relay (Used w/Option 16)
KV	Voting Relay
MSS	Maintenance Selector Switch
NASx	Normal Lockout (x = contact number)
Nx	Power Terminal, Normal (x = Terminal number)
NL	Normal Position Indicator Light
NMPB	Normal Pushbutton for Manual Operation
NR	Normal Relay Coil
NRx	Normal Relay Contact (x = contact number)
NRA	Normal Auxiliary Relay Coil
NRAx	Normal Auxiliary Relay Contact (x = contact number)
NSx	Normal Auxiliary Switch (x = contact number)
NT1	Normal Transformer (Line Voltage to 120vac - 2 windings)
NT2	Normal Transformer (120 to 24vac CT)
NT3	Normal Transformer (Line Voltage to 12vac)
NT4	Normal Transformer (Line Voltage to 12vac)
Px-y	plug (x = number, y = Terminal number)
PBEN	Bypass TDEN Pushbutton
PBNE	Bypass TDNE Pushbutton
PBRN	Pushbutton Reset Emergency Trip
PBRN	Reset Normal Breaker Trip Pushbutton
PE	Plant Exerciser
PSDR	pre-transfer Signal Device Relay
PSDT	pre-transfer Signal Device Timer
PSS	Preferred Source Selector Switch
Sx-y	Socket (x = number, y = Terminal number)
SDL	Service Disconnect Light
SDSS	Service Disconnect Selector Switch
SD	Services Disconnected Light
SEA	Emergency Source Available Indicator Light
SN	Normal Source Available Indicator Light
Tx	Power Terminal, Load (x = Terminal Number)
TDCL	Time Delay Crank Time Limiter
TDEC	Time Delay Engine Cool Down
TDEN	Time Delay Emergency to Normal
TDES	Time Delay Engine Start
TDNC	Time Delay Neutral
TDNE	Time Delay Normal to Emergency
TE	Emergency Trip Indicator Light
TM	Transfer Motor and Brake
TN	Normal Trip Indicator Light
TPB	Test Pushbutton
TSS	Test Selector Switch
VM	Voltmeter

**Cutler-Hammer  
Beaver, PA**

Automatic Transfer Switch

Type NTVS Wiring Diagrams

Version 1.0 May 1, 1995

Copyright 1995 by Eaton/Cutler Hammer Inc.  
All rights reserved

Page No.

Date

VTPPER DWG	1 Feb 95
VSSNFGR DWG	2 Apr 95
VSSNTE DWG	25 Oct 94
VSS01 DWG	1 Feb 95
VSS02 DWG	1 Feb 95
VSS03 DWG	10 Feb 95
VSS04 DWG	10 Feb 95
VSS05 DWG	9 Feb 95
VSS05A DWG	9 Feb 95
VSS06 DWG	9 Feb 95
VSS07 DWG	9 Feb 95
VSS08 DWG	9 Feb 95
VSS09 DWG	6 Feb 95
VSS10 DWG	6 Feb 95
VSS11 DWG	7 Feb 95
VSS12 DWG	7 Feb 95
VSS13 DWG	17 Feb 95

Plug - Pin assignments for the SOLID STATE LOGIC Transfer Switch

P1 - Switching Panel

N1 - Transformer Panel

1	Normal	N1	Phase A
2	Normal	N2	Phase B
3	Normal	N3	Phase C
4	Normal	N1	Phase A
5	Normal	N2	Phase B
6	Normal	N3	Phase C
7	N Aux Sw #1	N O	
8	N Aux Sw #1	C	
9	N Aux Sw #1	N C	
10	N Aux Sw #2	N O	
11	N Aux Sw #2	C	
12	N Aux Sw #2	N C	
13	N Aux Sw #3	N O	
14	N Aux Sw #3	C	
15	N Aux Sw #3	N C	

P2 - Switching Panel

S2 - Transformer Panel

1	Emergency	E3	Phase C
2	Emergency	E2	Phase B
3	Emergency	E1	Phase A
4	Emergency	E3	Phase C
5	Emergency	E2	Phase B
6	Emergency	E1	Phase A
7	E Aux Sw #1	N O	
8	E Aux Sw #1	C	
9	E Aux Sw #1	N C	
10	E Aux Sw #2	N O	
11	E Aux Sw #2	C	
12	E Aux Sw #2	N C	
13	E Aux Sw #3	N O	
14	E Aux Sw #3	C	
15	E Aux Sw #3	N C	

P3 - Switching Panel to  
S3 - Transformer Panel

1	Load	T1	Phase A
2	Load	T2	Phase B
3	Load	T3	Phase C
4	Motor	Bridge "AC" In	
5	Motor	Bridge "AC" In	
6			
7	Lockout (Normal)	NC	
8		Com	
9		NO	
10	Lockout (Emergency)	NC	
11		Com	
12		NO	

P4 - Transformer Panel to  
S4 - Intelligence Panel

1	Motherboard 1
2	Motherboard 2
3	Motherboard 3
4	Motherboard 4
5	Motherboard 5
6	Motherboard 6
7	Motherboard 7
8	Motherboard 8
9	Motherboard 9
10	Motherboard 10
11	Motherboard 11
12	Motherboard 12
13	Motherboard 13
14	Motherboard 14
15	

S5 - Transformer Panel to  
P5 - Intelligence Panel - Door

1	Normal Control Power
2	Emergency Control Power
3	Control Neutral
4	Operate to Normal
5	Operate to Emergency
6	Normal Position Light
7	Emergency Position Light
8	Normal Logic Interrupt - Test Pushbutton
9	Normal Logic Interrupt - Test Pushbutton
10	Emergency Logic Interrupt
11	Emergency Logic Interrupt
12	Engine Start Circuit Source 1 - Optional
13	Engine Start Circuit Source 2 - Optional

- 14 Engine Start Circuit Source 2
- 15 Engine Start Circuit Source 2

S6 - Transformer Panel 1  
P6 - Intelligence Panel - Drive

- 1 Motor Circuit Interrupt TB 53
- 2 Motor Circuit Interrupt TB 54
- 3 Motor Circuit Interrupt TB 55
- 4 N Trip
- 5 E Trip

S7a - g Voltage Selector - Socket  
P7 - Plug

- 1 NT3
- 2 NT4
- 3 NT1
- 4 ET1
- 5 ET4
- 6 ET3

# Cutler-Hammer Automatic Transfer Switch Wiring Diagrams

## Directions for Use

The drawing package can be used as a point to point wiring diagram for maintenance and diagnostic purposes for Solid State Logic Transfer Switches, 150 - 1000 Ampere, all voltages.

This document contains the following wiring information:

- Basic Switching Panel Wiring
- Basic wiring diagrams for the transformer and intelligence panels.
- Wiring for all normally available features (Options)
- Legend Sheet describing symbols used throughout this document.

Note: Additional sheets may be provided with this document on occasion to illustrate custom wiring provided for a specifically supplied function which is not normally available.

## Legend Sheet

BR	Bridge Rectifier
EL	Emergency Position Indicator Light
ER	Emergency Relay
ERA	Emergency Auxiliary Relay
ERB	Emergency Auxiliary Relay
ETx	Emergency Transformer
Ex	Emergency Power Terminal x
FPSS	Four Position Selector Switch (Option 6H)
KB	Brake Relay
KE	Emergency Failsafe Relay
KF	Failsafe Relay
MSS	Maintenance Selector Switch
NL	Normal Position Indicator Light
NR	Normal Relay
NRA	Normal Auxiliary Relay
NRB	Normal Auxiliary Relay
NTx	Normal Transformer x
Nx	Normal Power Terminal x
PBEN	Pushbutton Bypass TDEN timer
PBNE	Pushbutton Bypass TDNE timer
PE	Plant Exerciser Clock
PSDR	Pretransfer Signal Relay
PSDT	Pretransfer Signal Timer
Px-y	"Plug Number x. Pin Number y"
SDSS	Service Disconnect Selector Switch
Sx-y	"Socket Number x. Pin Number y"
TDCL	Time Delay Crank Limiter
TDEC	Time Delay Engine Cooloff
TDEN	Time Delay Emergency to Normal
TDES	Time Delay Engine Start
TDN	Time Delay Neutral
TDNE	Time Delay Normal to Emergency

# 100 Amp Switching Panel Assembly

Cat No ATHS or ATHE ONLY

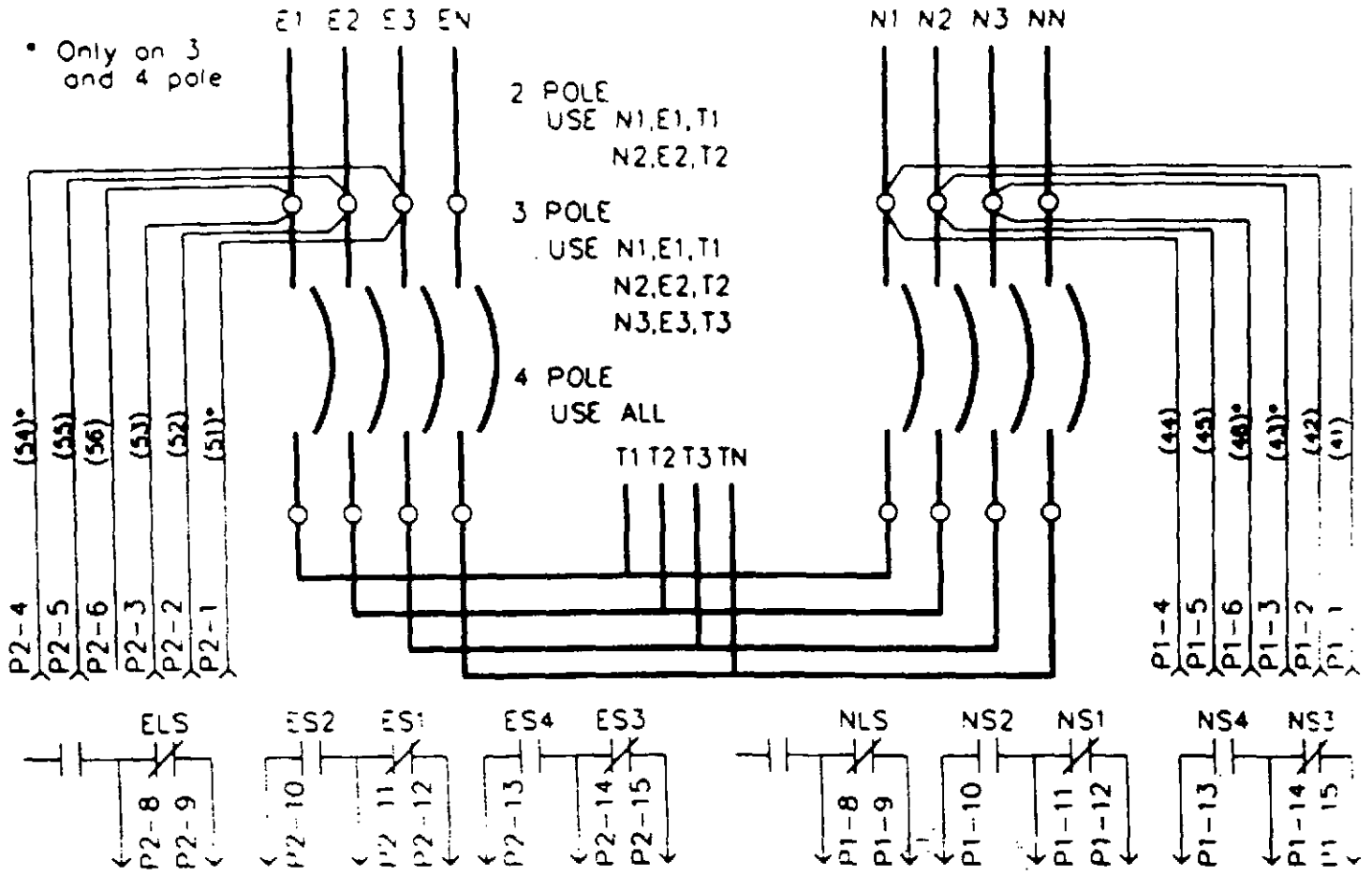

NLS and ELS are located on the mechanism

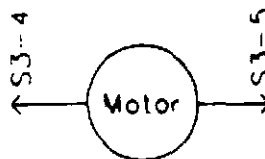
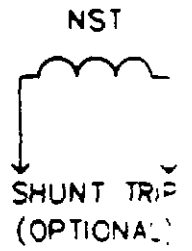
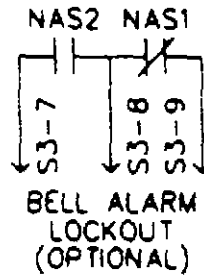
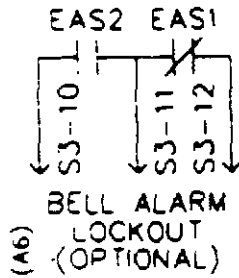
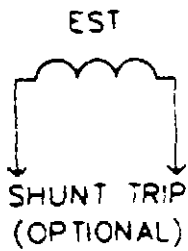

# Switching Panel (150 - 1000 Ampere, 2,3, or 4 pole)

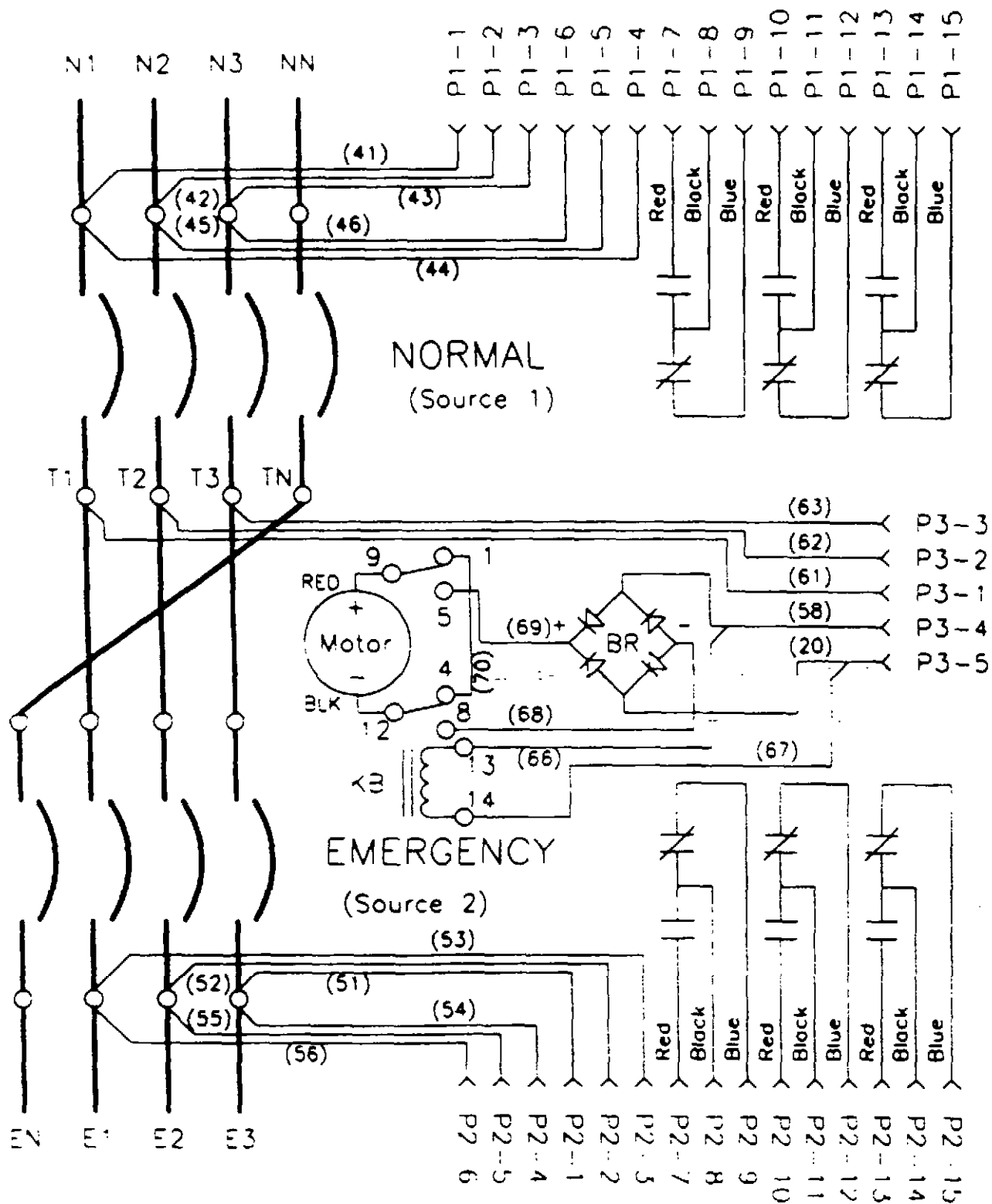

# Solid State Logic Transformer Panel

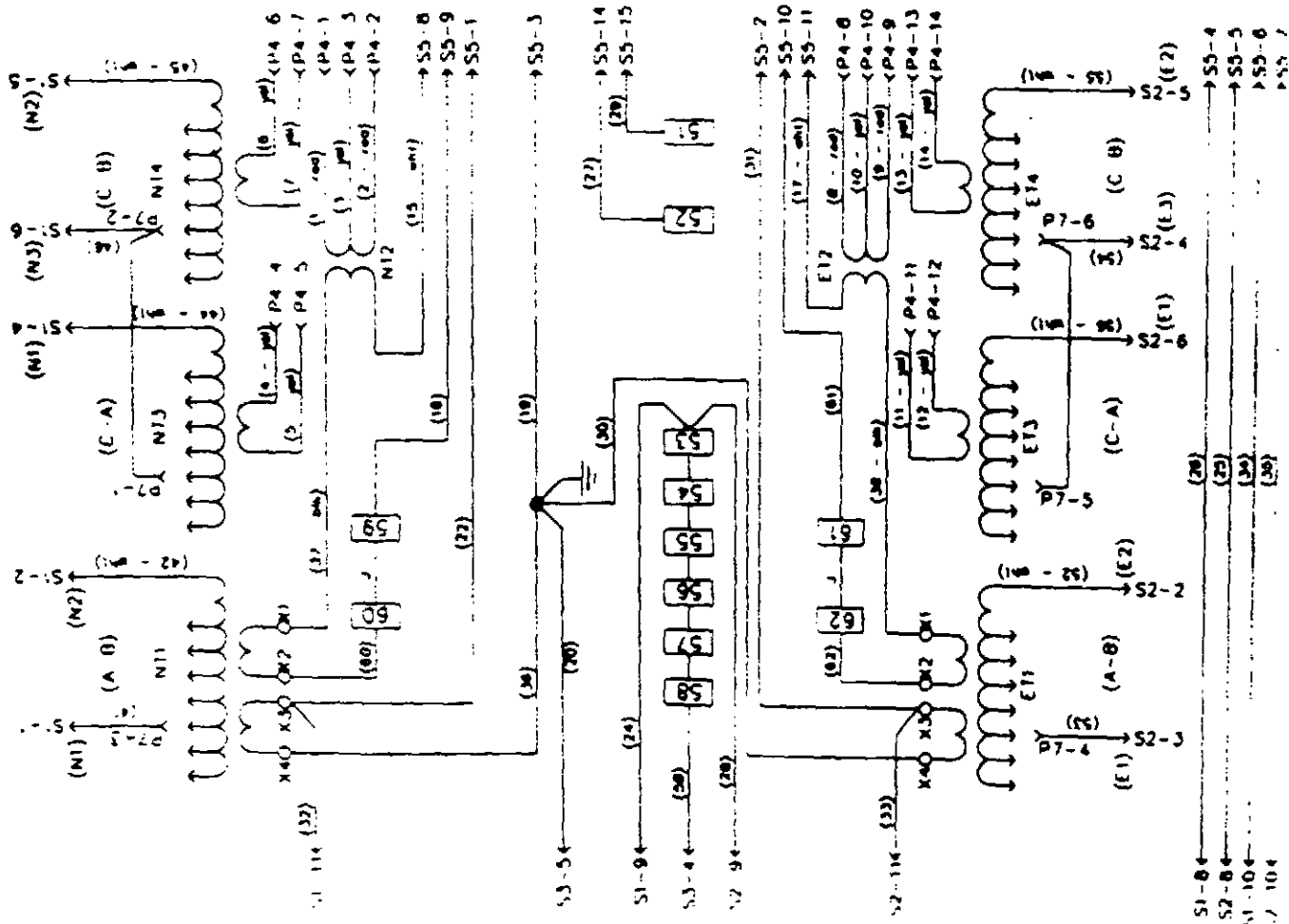

# P7/S70-g Detail

	208	blk
	220	brn
	240	blu
	380	grn
	415	blk/wht
	480	grn/wht
	600	red

- Pin Assignments
- 1 - N13
  - 2 - N14
  - 3 - N11
  - 4 - E11
  - 5 - E12
  - 6 - E13

# Intelligence Panel

Cat. NTVS Only

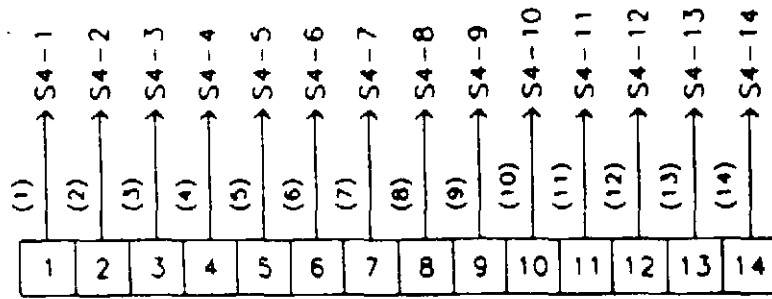

P5-3 >

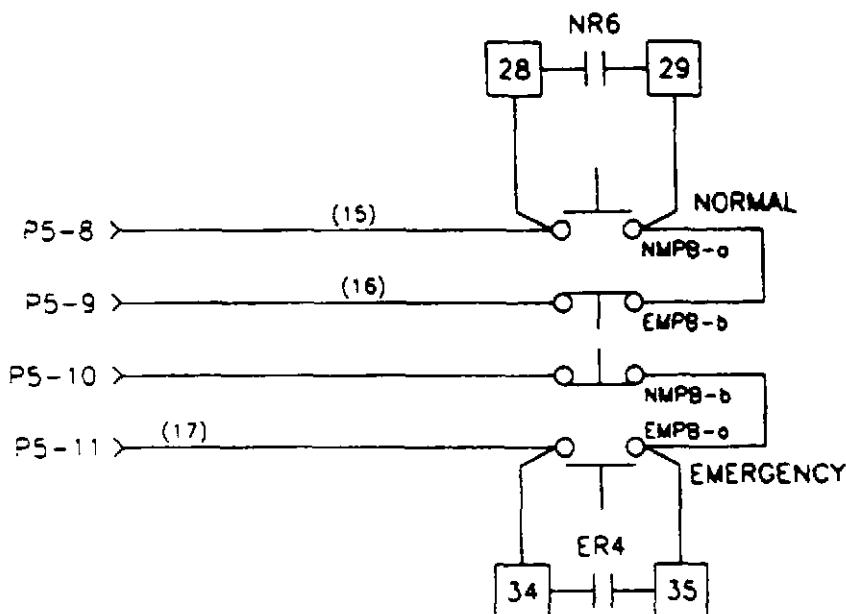
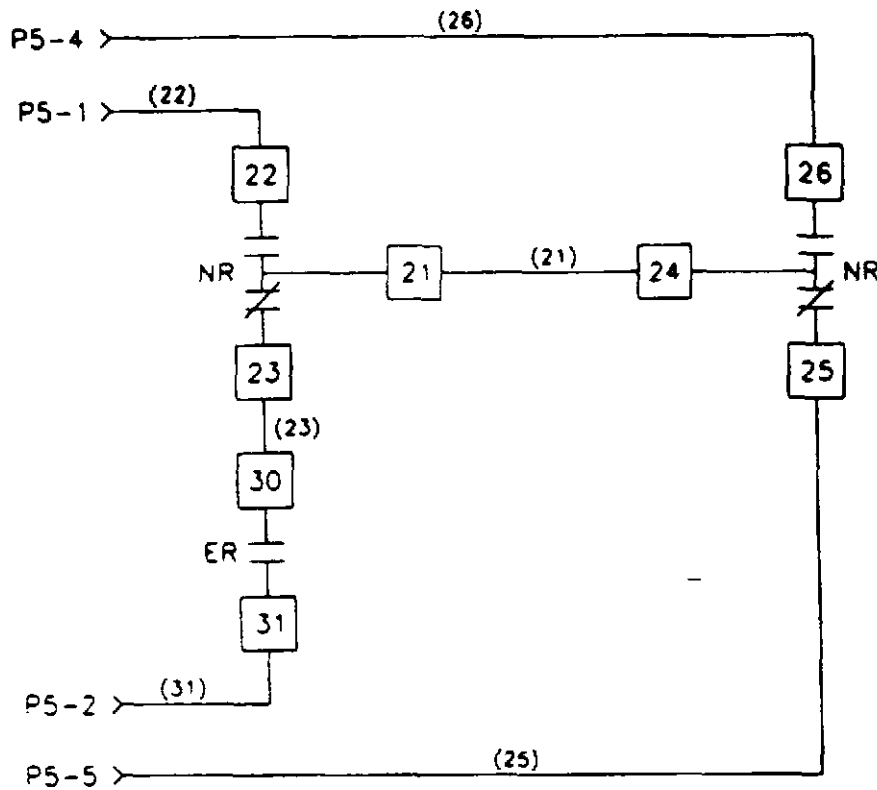

6 Position Card Cage

9 Position Card Cage

Undervoltage Standard
Driver (Option 3)
Blank (Option 4)
Driver (Option 1)
Blank (Option 5)
Blank (Option 5)

Undervoltage Standard
Blank (Option 26)
Blank (Option 26)
Driver (Option 3)
Blank (Option 4)
Driver (Option 1)
Blank (Option 5)
Blank (Option 5)
Blank (Option 5)

Option 1 Time Delay Normal to Emergency (TDNE)

6 Position Card Cage  
Replace Driver Card in Position 2  
with Timer Card

9 Position Card Cage  
Replace Driver CARD in Position 4  
with Timer Card

Option 2 Time Delay Engine Start (TDES)

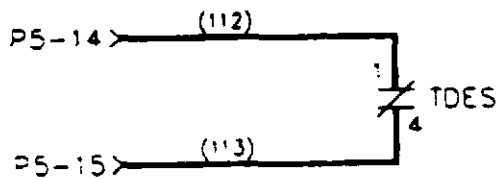
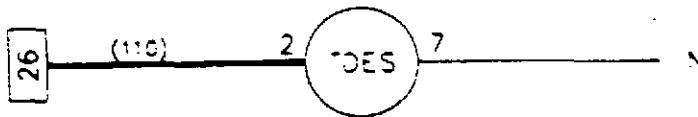

Remove wires: #27 (P5-14 to Term 27)  
and #29 (P5-15 to Term 29)

Option 3 Time Delay Emergency to Normal (TDEN)

6 Position Card Cage  
Replace Driver Card in Position 4  
with Timer Card

9 Position Card Cage  
Replace Driver Card in Position 6  
with Timer Card

# Option 4 Time Delay Engine Cooloff (TDEC)

6 Position Card Cage

Replace Blank Card in Position 3  
with Timer Card  
Add EC Relay to Motherboard

9 Position Card Cage

Replace Blank Card in Position 5  
with Timer Card  
Add EC Relay to Motherboard

Remove wres: #27 (P5-14 to Term 27)  
and #29 (P5-15 to Term 29)

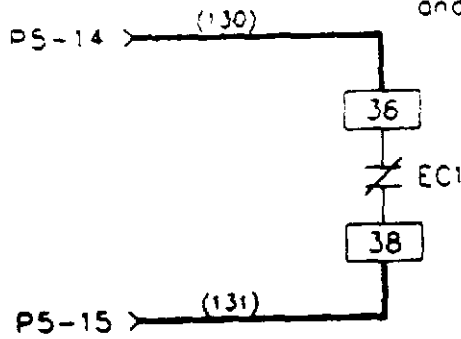

Option 4 Only

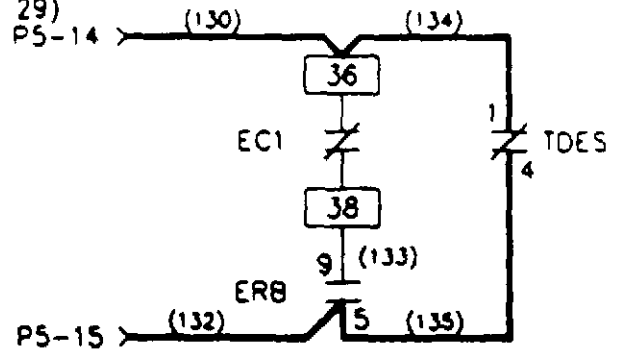

Option 4 with/Option 2

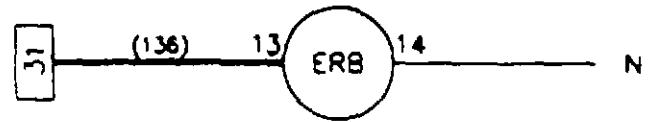

# Option 5 Voltage/Frequency Sensing on Emergency

6 Position Card Cage

Replace BLANK Card in Position 5 or 6  
with Appropriate Sensing Card

9 Position Card Cage

Replace BLANK Card in Position 7,8, or 9  
with Appropriate Sensing Card

# Option 6H Four Position Test Switch (FPSS)

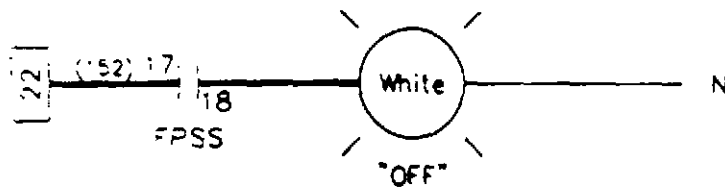
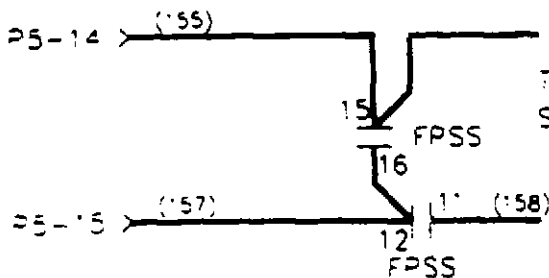
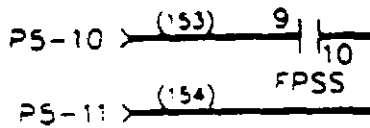
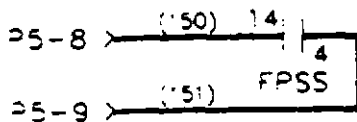

	9 10	11 12	4 14	15 16	17 18
TEST	X	X			
AUTO	X	X	X		
OFF					X
ENG. RUN	X		X	X	

Option 8C Bypass TDEN Timer (PBEN)

Remove Wire #17

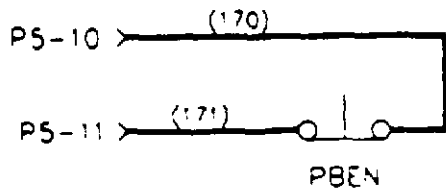

Option 8C Only

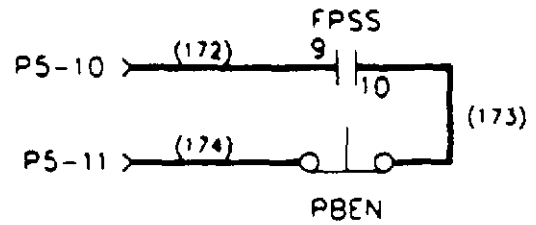

Option 8C w/Option 6H

Option 8D Bypass TDNE Timer (PBNE)

Remove Jumper

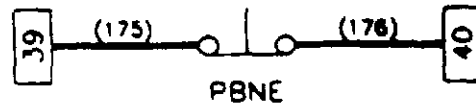

Option 9 Maintenance Selector Switch (MSS)

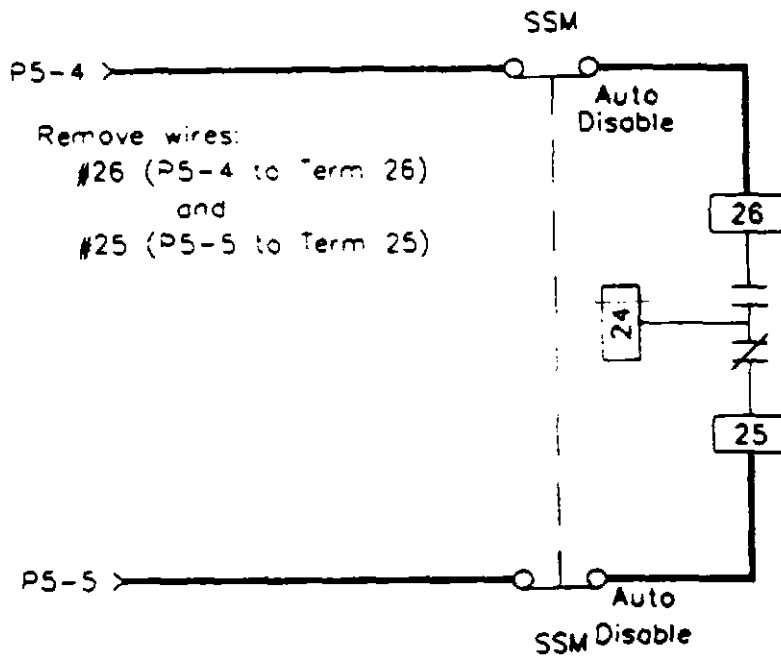

Option 12C Normal Position Light (NL)

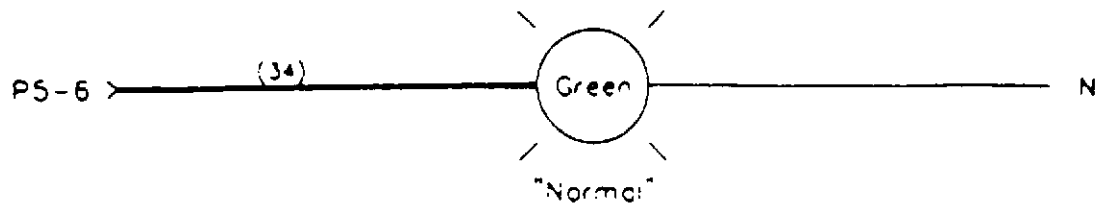

Option 12D Emergency Position Light

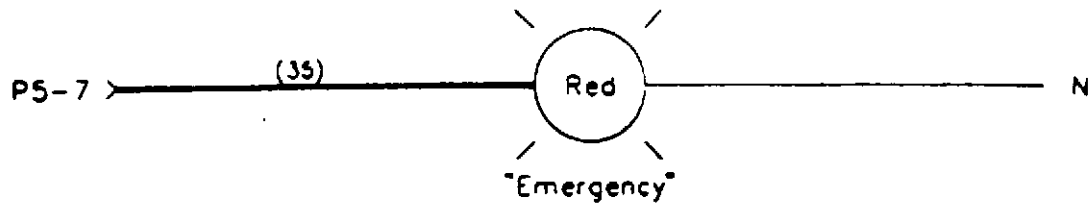

Option 12G Normal Source Light

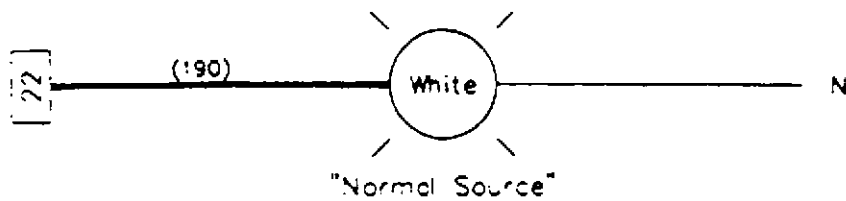

Option 12- Emergency Source Light

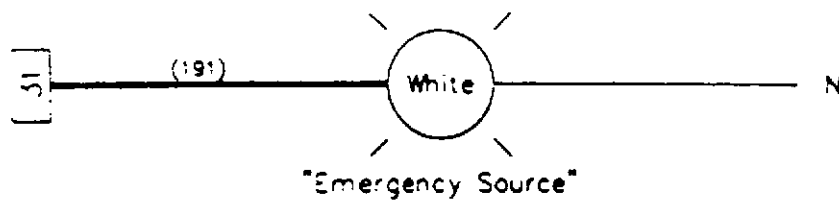

Option 12L Trip Indicator Light

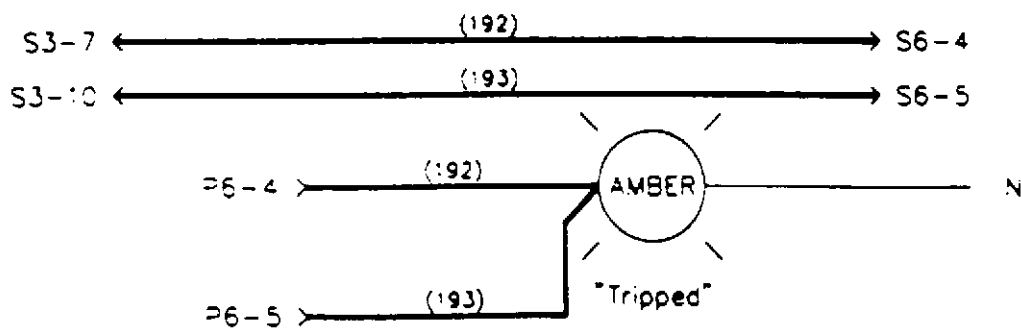

Option 14C Normal Auxiliary Relay (NRA)

Remove Wire from S1-8 to S5-4

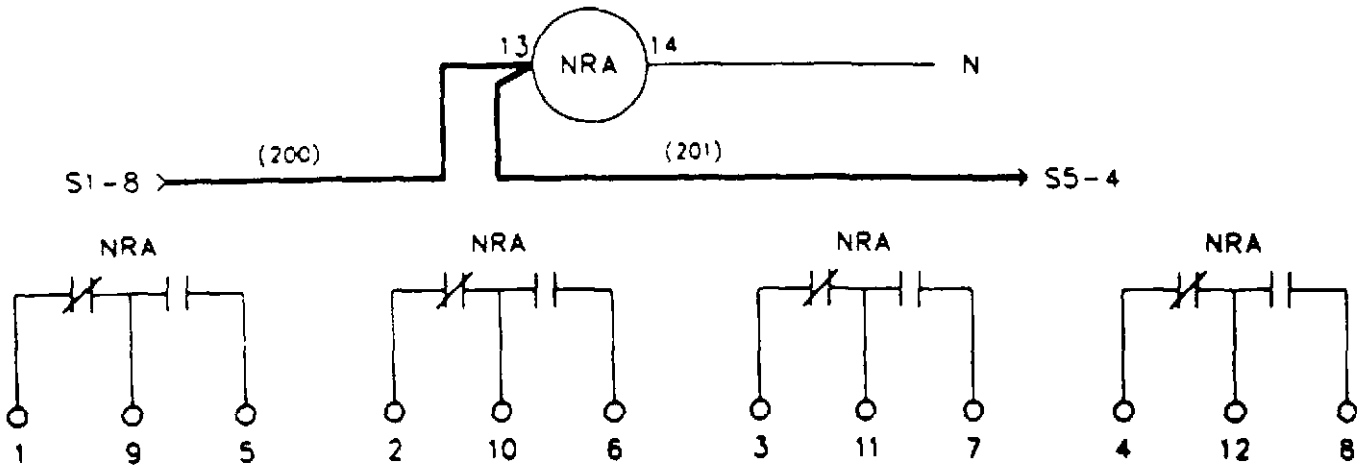

Option 14D Emergency Auxiliary Relay

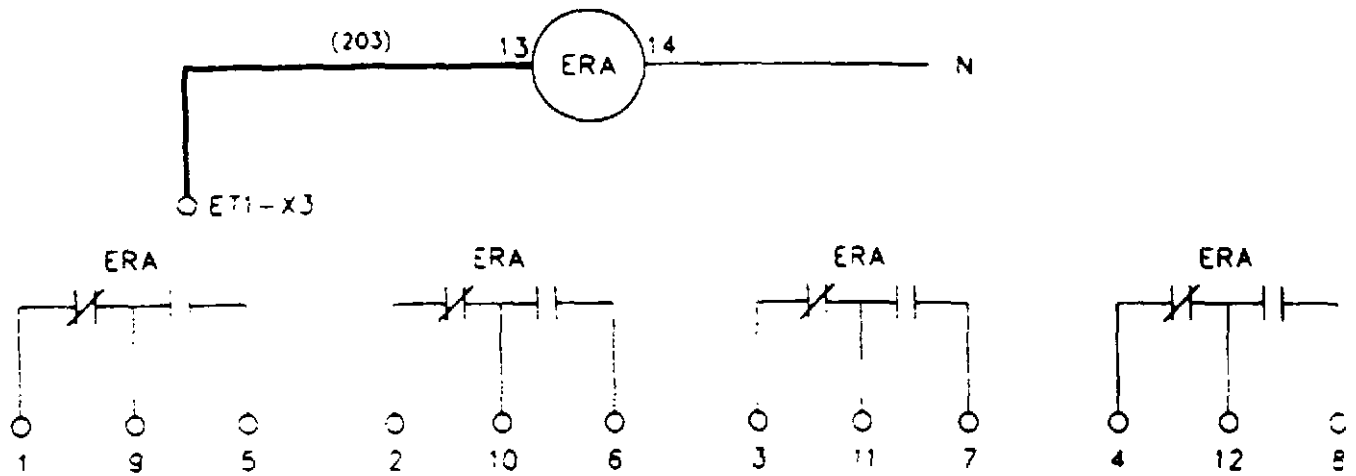

NRA/ERA Relay Socket

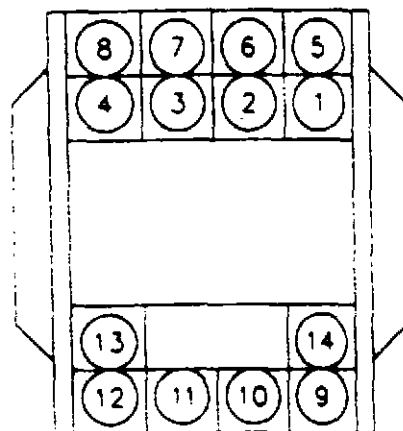

Option 16 Thermal Magnetic Trips

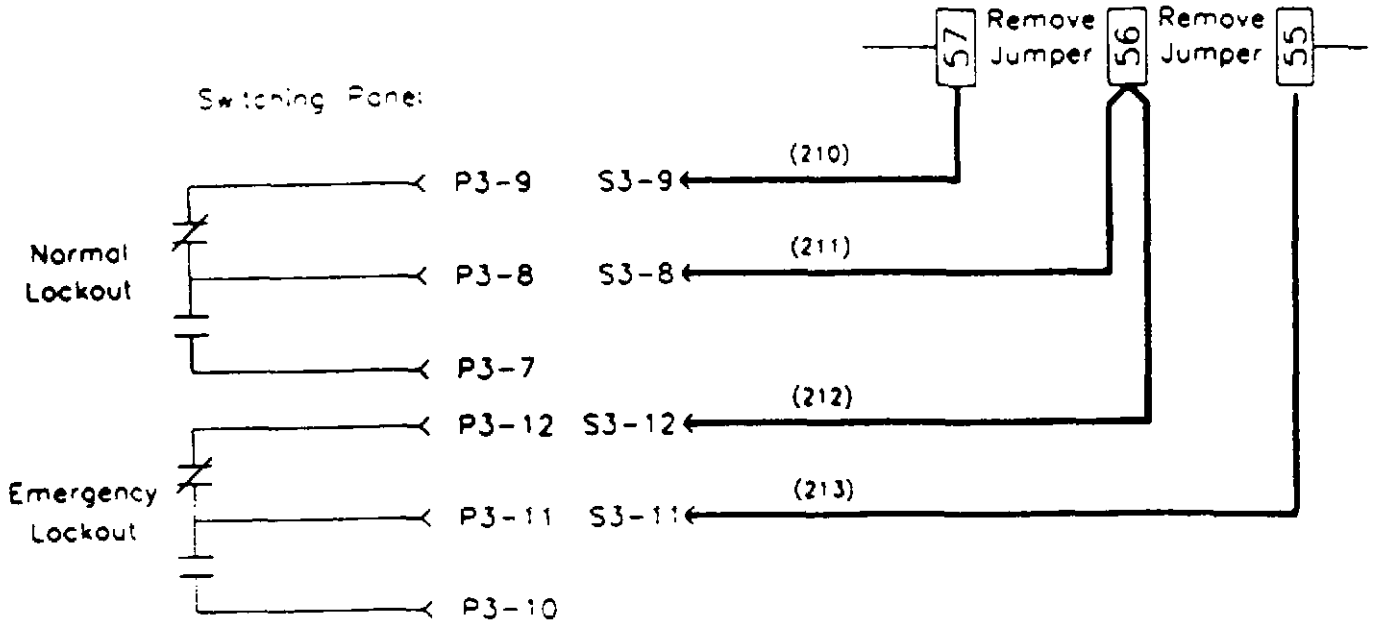

\*bell Alarms must be installed in the MCCB

Option 23C Plant Exerciser

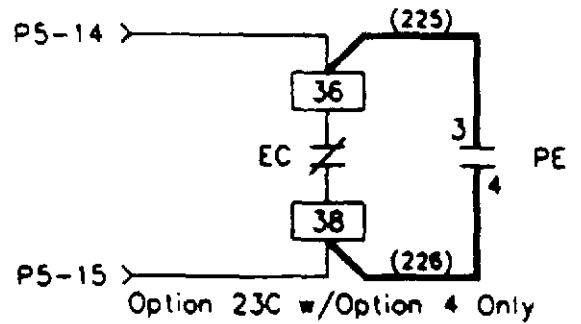
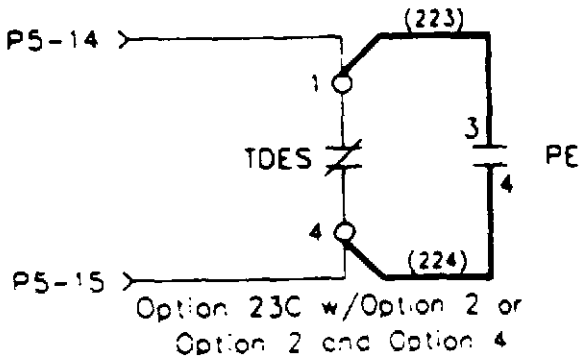
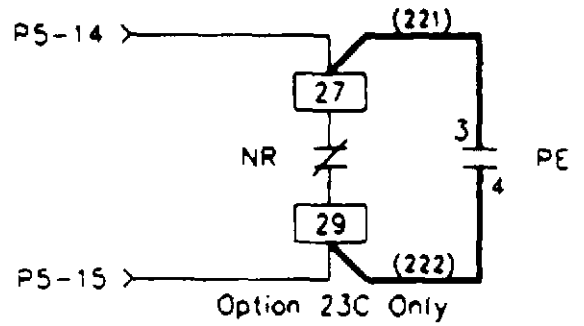
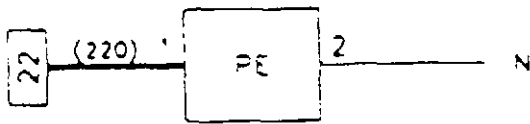

Option 23D Plant Exerciser

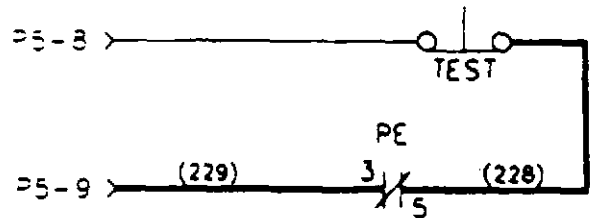
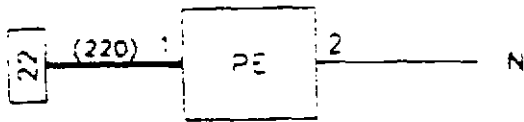

Option 23 Plant Exerciser

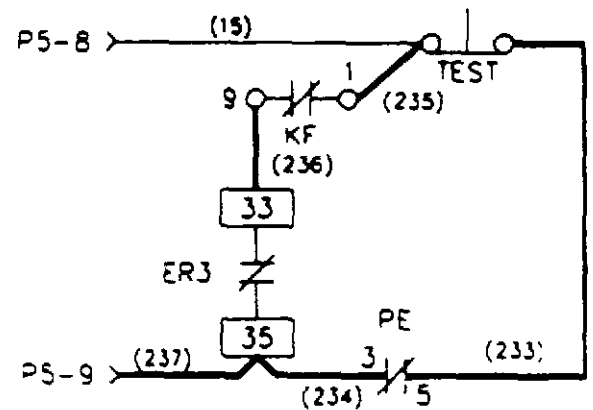
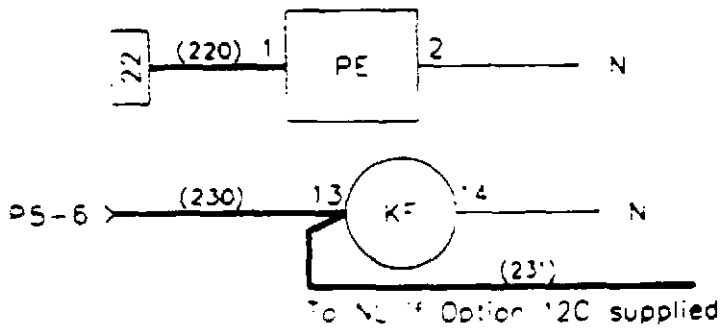



Option 23J Plant Exerciser

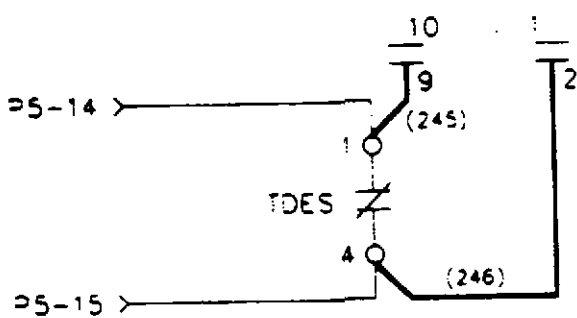
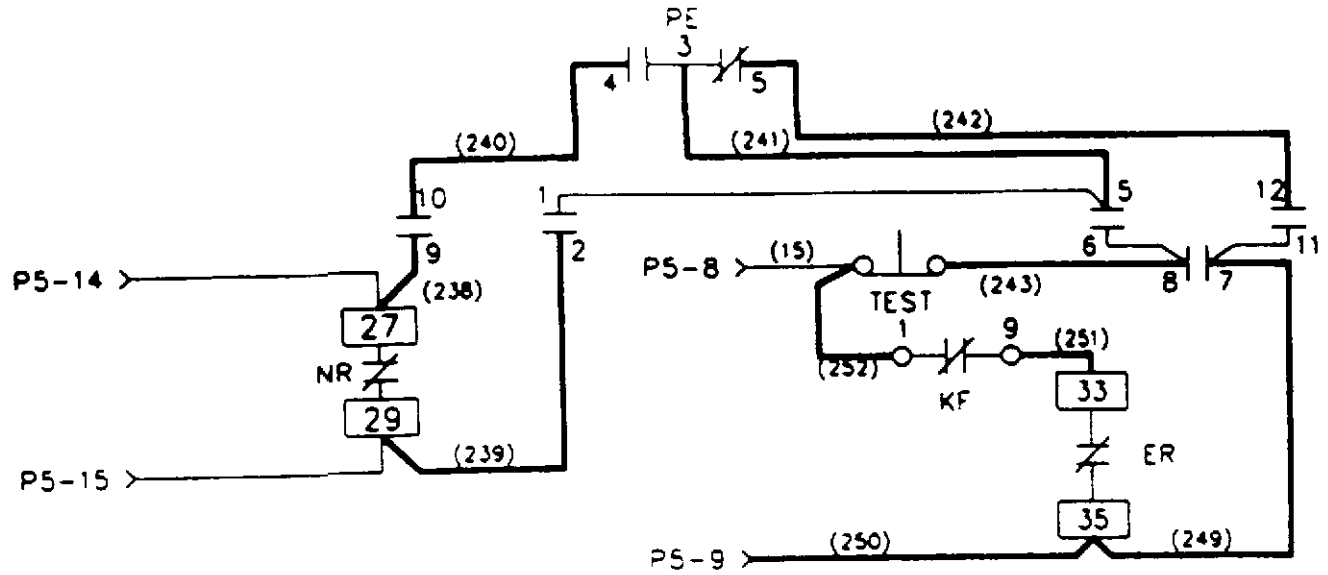
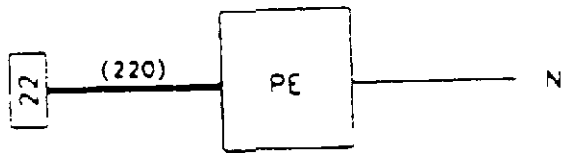

Option 23G w/Option 2 or  
Option 2 and 4

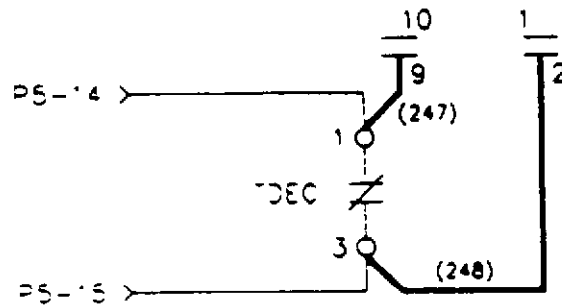

Option 23G w/Option 4 Only

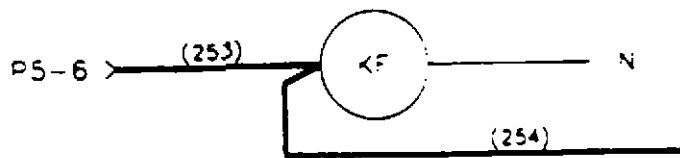

To NL if Option 23C is supplied

Option 29E Manual Return to Normal

DO NOT supply Option 3 with this option!

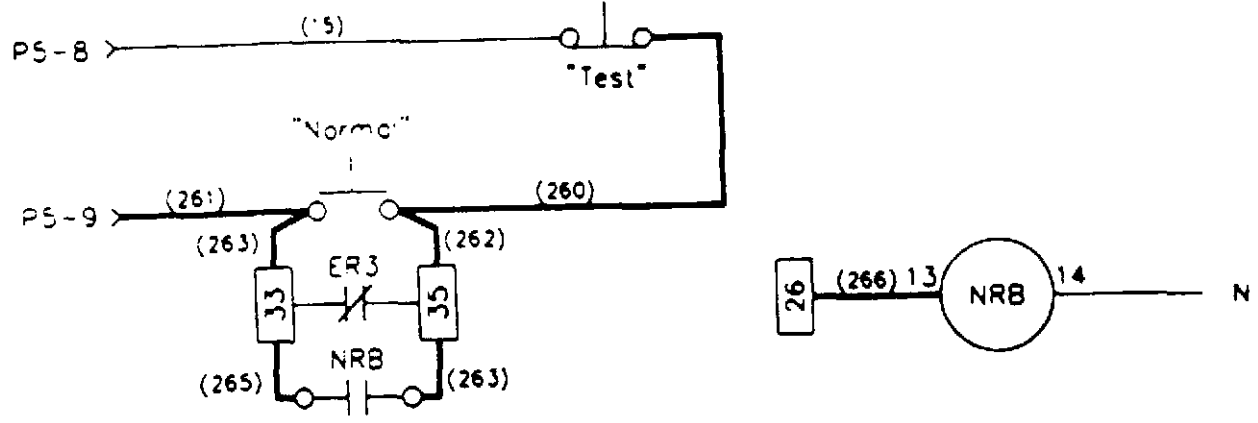

Option 29J Automatic/Manual Return to Normal

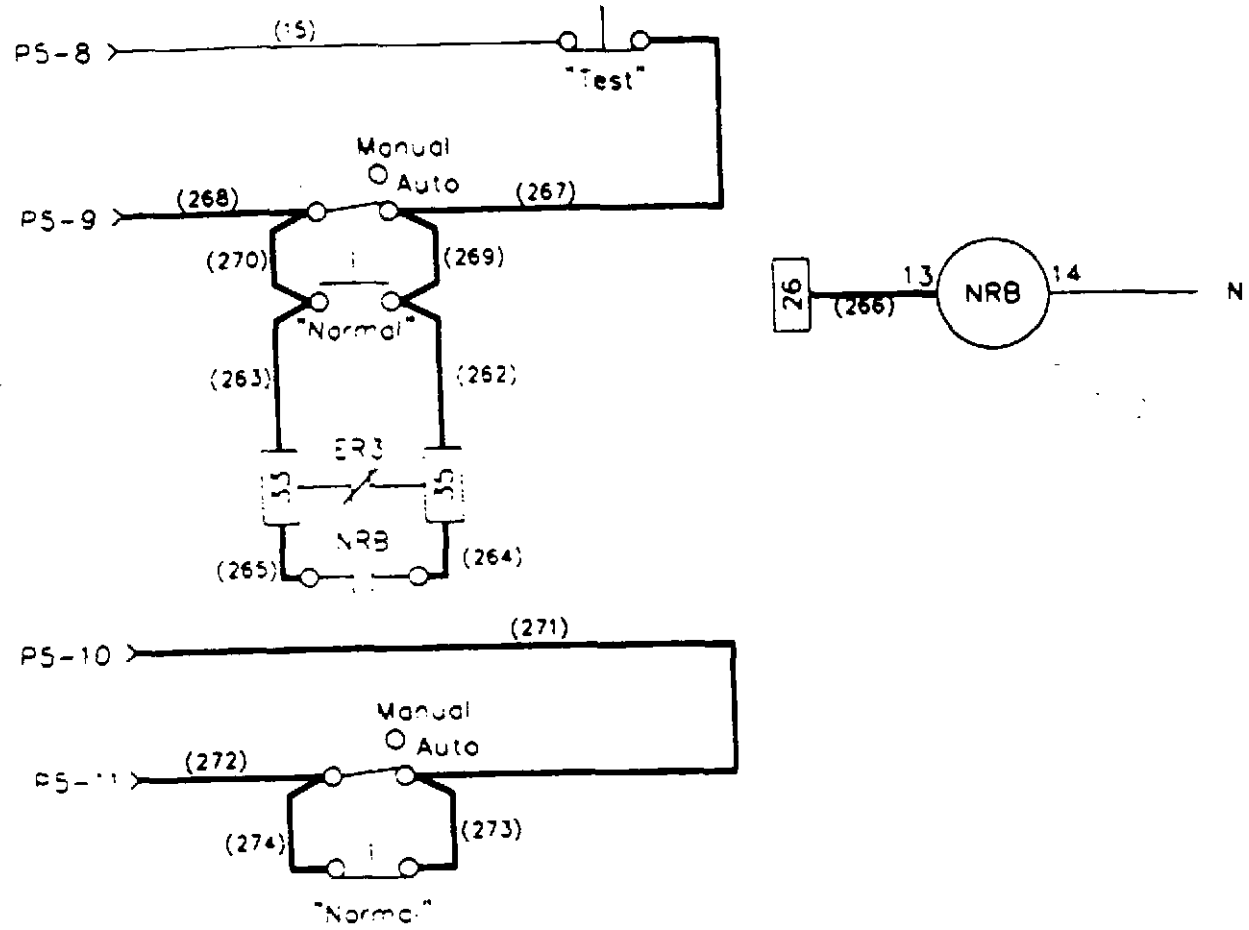

Option 29G Automatic/Manual Operation

NOT UL Listable!

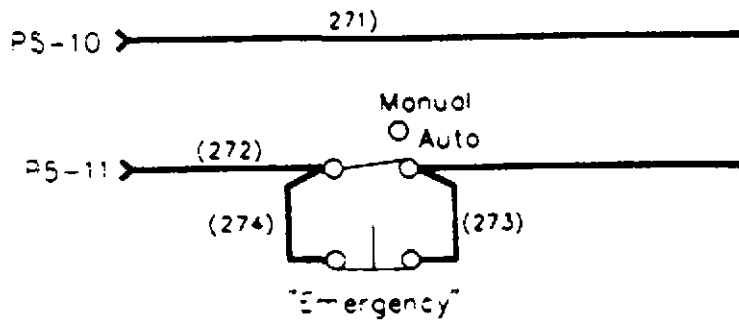
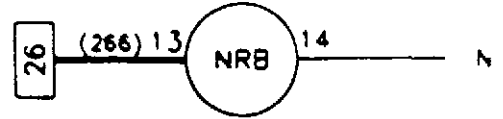
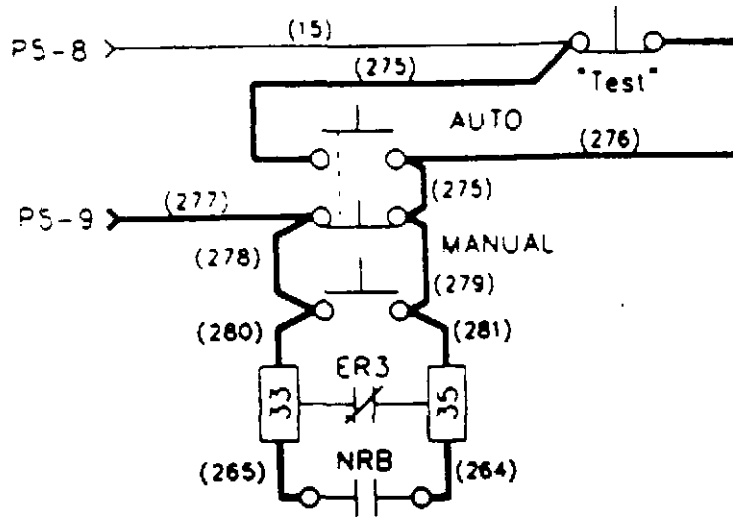

Option 30 Time Delay Crank Limiter

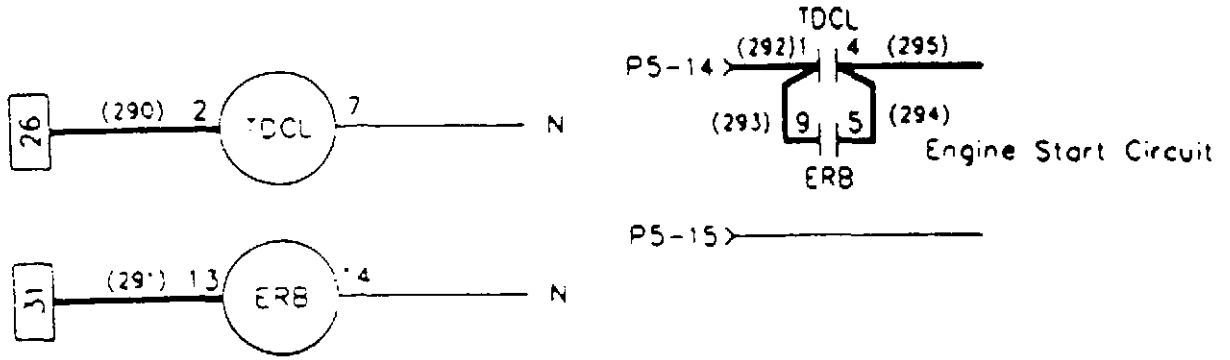

Option 32 Time Delay Neutral

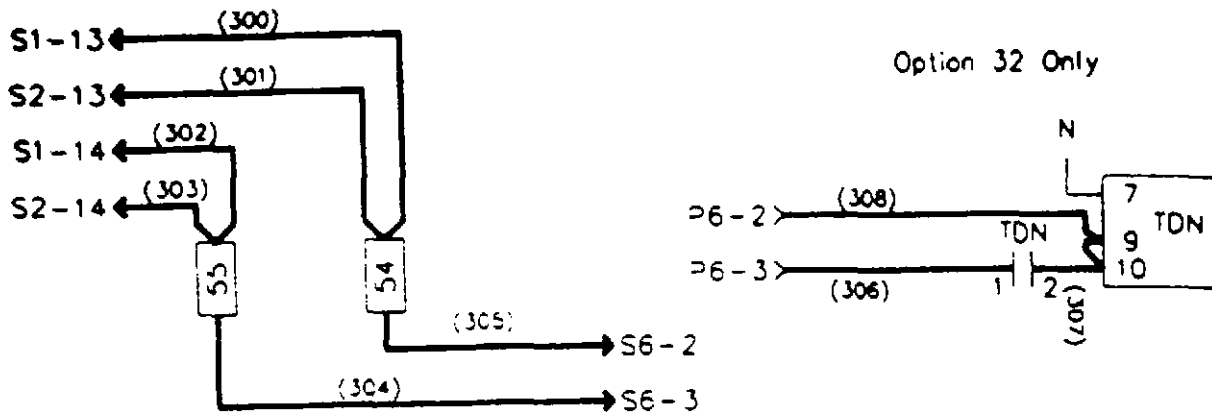

Option 35 Pretransfer Signal Device

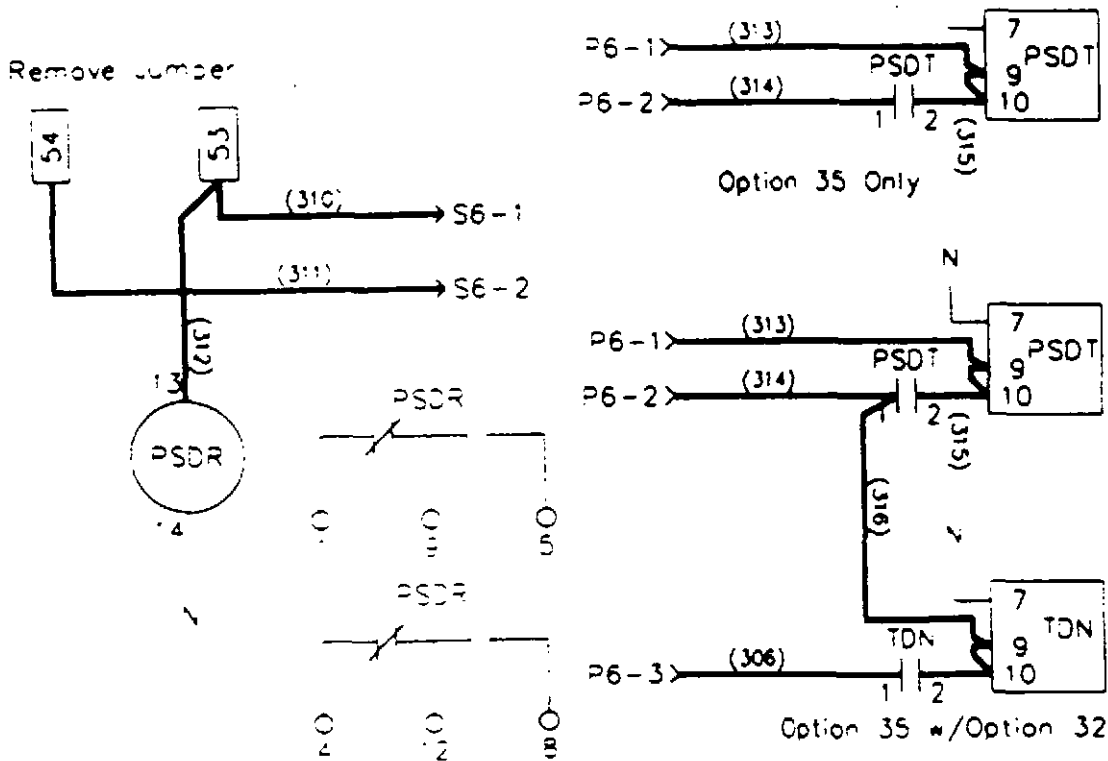

Option 37 Service Disconnect

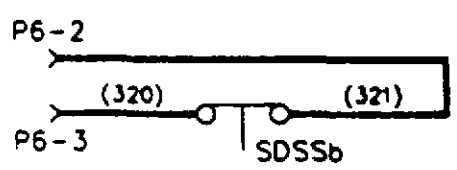
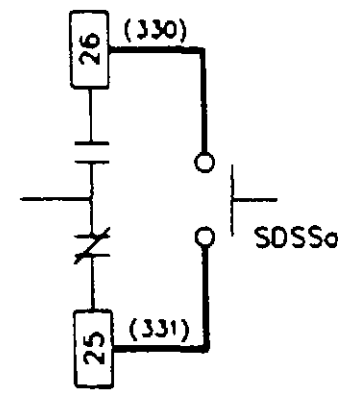
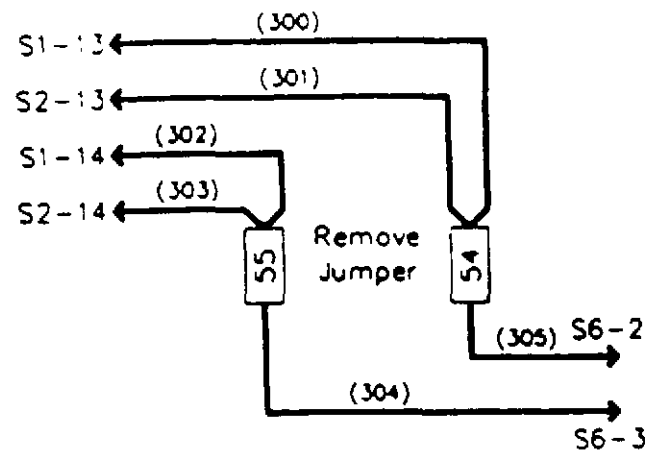

Option 37 Only

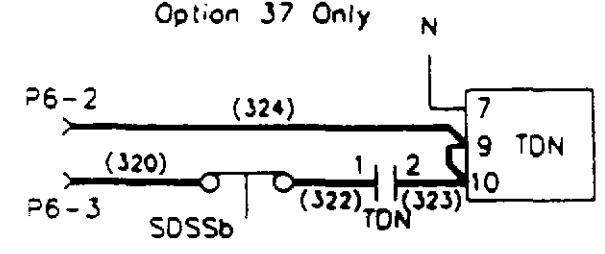

KF relay is also used for Option 23

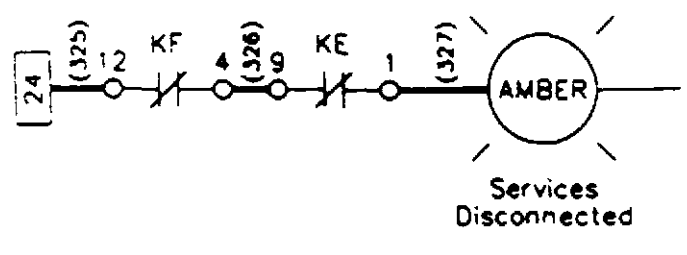
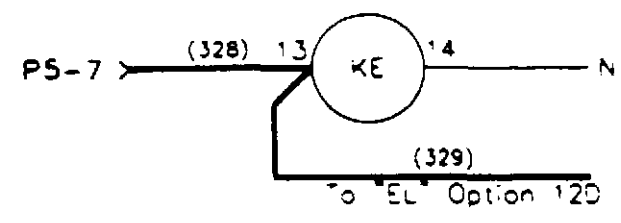
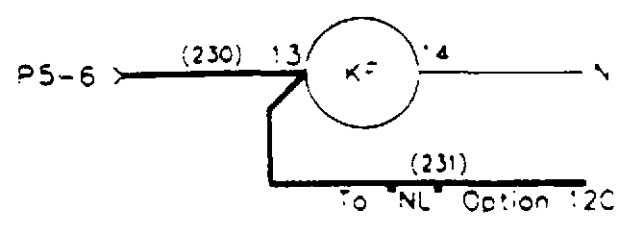

Option 10 B/D - Preferred Source Selector Switch

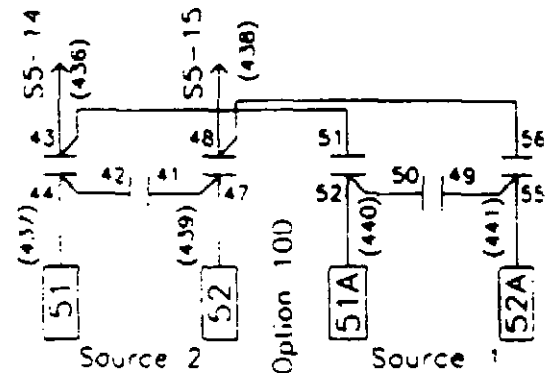
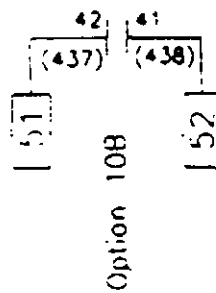
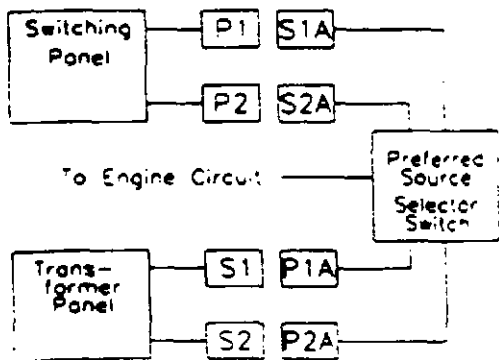
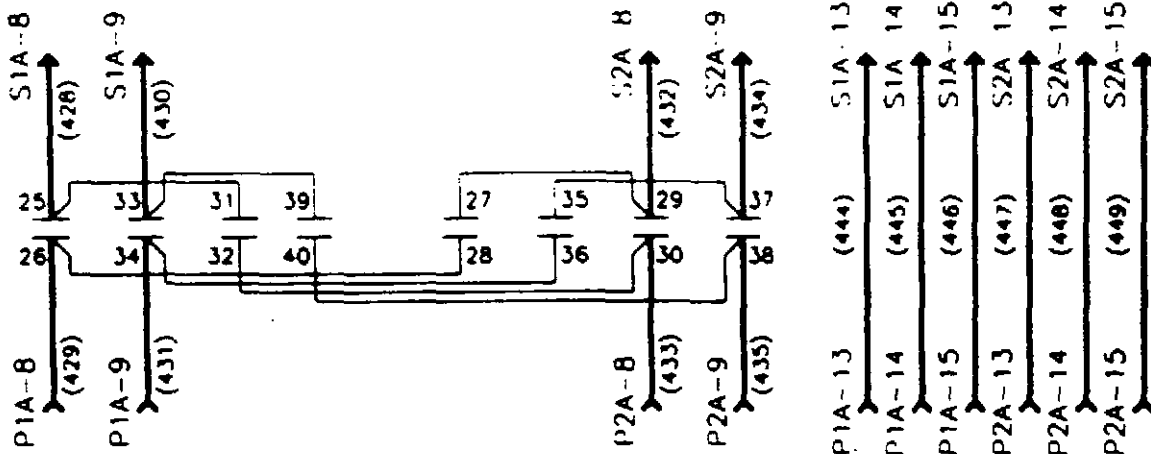
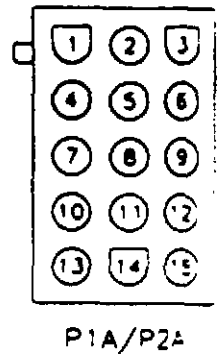
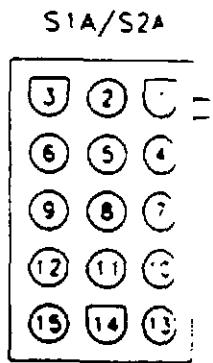
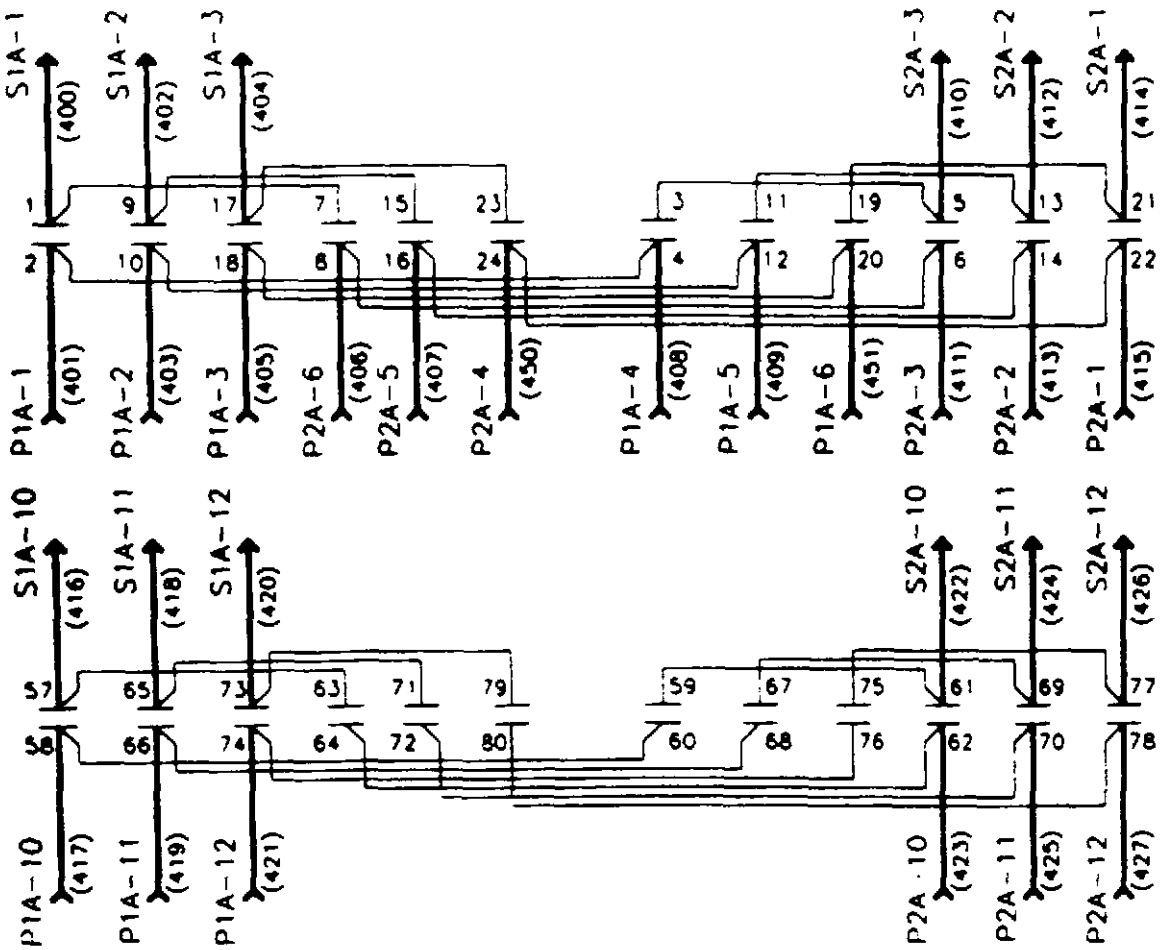





# **Cutler-Hammer Beaver, PA**

**Non-Automatic Transfer Switch**

**Type NTVSSP Wiring Diagrams**

**Cutler-Hammer  
Power Distribution Components Division  
One Tuscarawas Road  
Beaver, PA 15009**

**Copyright 1995 by Eaton/Cutler-Hammer Inc.  
All Rights Reserved**

**Version 1.0 3-29-93**

# Cutler-Hammer Non-Automatic Transfer Switch Wiring Diagrams

## Directions for Use

The drawing package can be used as a point to point wiring diagram for maintenance and diagnostic purposes for Solid State Logic SPB Transfer Switches, all voltages.

This document contains the following wiring information:

**Page 1**

Basic Solid State Intelligence Panel Wiring exclusive of added option functions

**Page 2**

Power Switching Panel basic wiring exclusive of added option functions.

**Pages 3 - 7**

Wiring for optional functions

**Page 8 - 9**

Legend Sheet describing symbols used throughout this document

Note: Unnumbered sheets may be added to this document on specific occasions to illustrate custom options additions per order instructions.

As a standard, transfer switch units will be wired as indicated by Pages 1, and 2. The Intelligence Panel and Power Panel are interconnected via keyed plug/socket connectors (P1-S1/P2-S2). Your specific unit may be equipped with certain optional functions as noted which require additional wiring as shown on pages 3 - 18.

Wiring for optionally added functions will typically interface with the basic unit wiring (Pages 1-2) which should be used as the base reference.

Note: **BOLD** lines on option wiring indicate components and wiring added to the basic wiring diagram to accomplish that specific option function.

# Cutler-Hammer Automatic Transfer Switch

## Standard Features

### **Engine Start Contact**

Contact that provides a closure to Engine Controller when the NORMAL Source fails.

### **Logic Disconnect**

Plugs provided to disconnect the logic circuitry for maintenance purposes.

### **Auxiliary Contacts**

Auxiliary contacts integral to the switching devices rated at 120 VAC, 10 amps. These may be applied for customer use, and may be applied to certain customer specified options.

### **Fully Rated Neutral**

A fully rated solid neutral is supplied on all two and three pole switches. All four pole switches are supplied with switched neutral contacts of identical construction and rating as the power poles.

# SPB ATS INTELLIGENCE PANEL CATALOG MTRSM ONLY

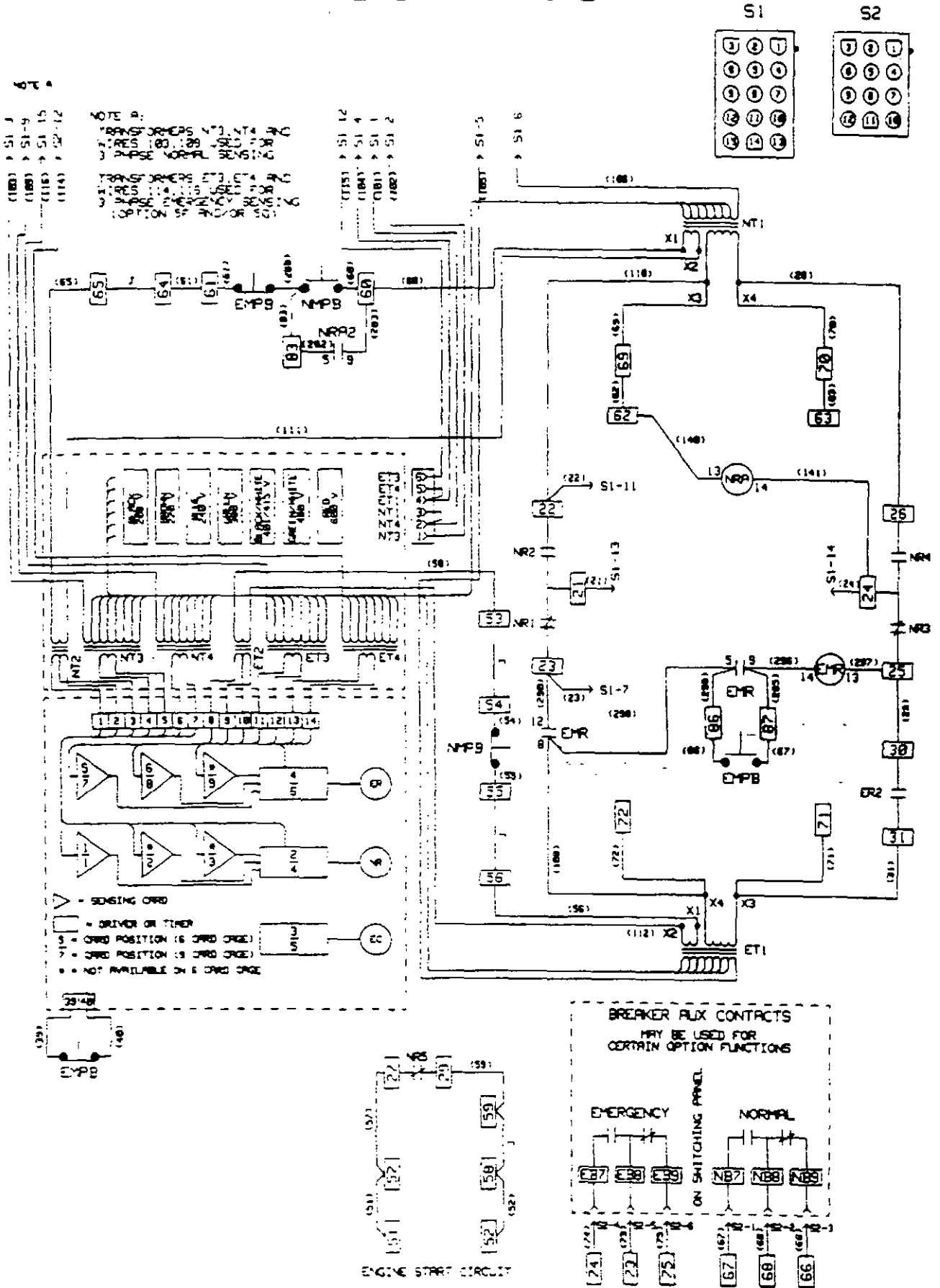

# SPB POWER SWITCHING PANEL (FIXED MOUNT)

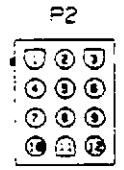
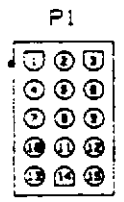
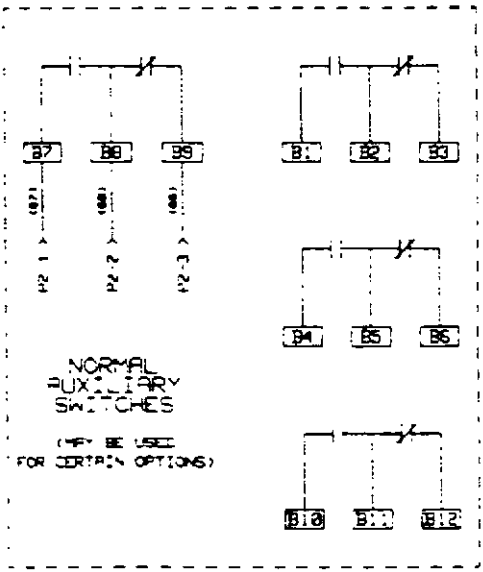
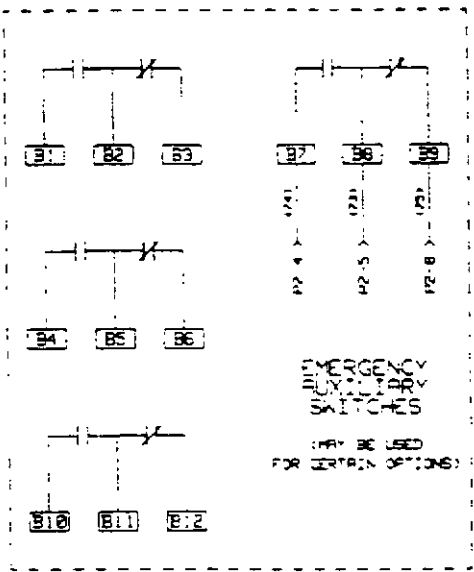
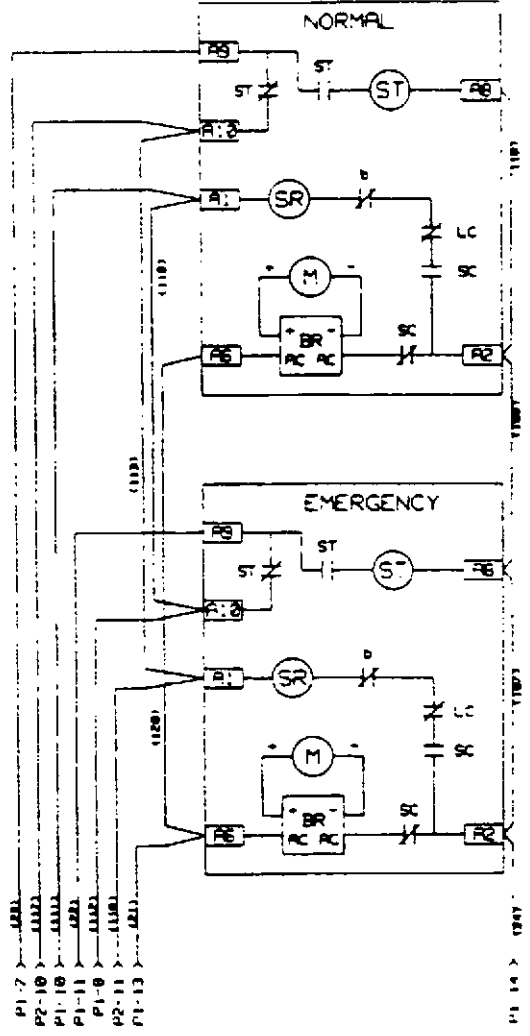
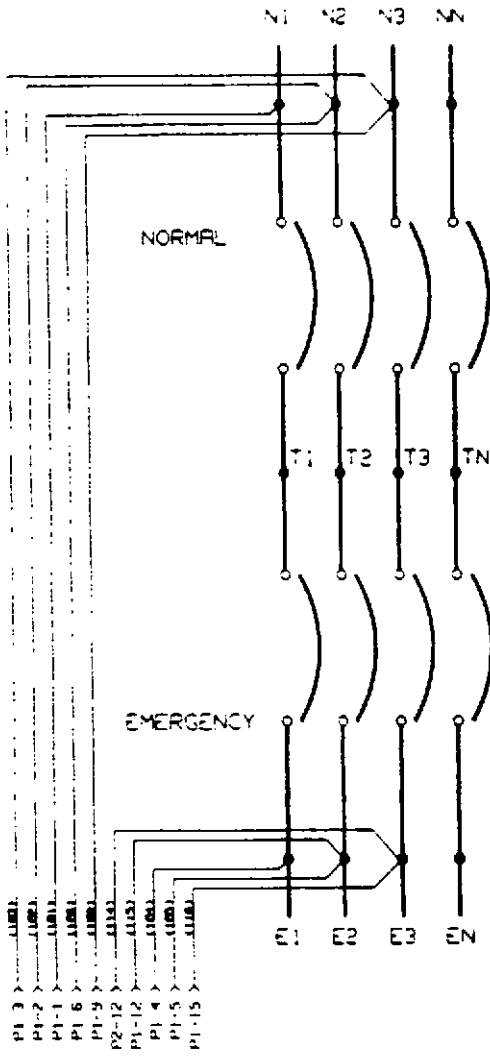



8 POSITION CARD CAGE

NORMAL		ENG	EMERGENCY		
1	2	3	4	5	6
BLANK (OPTION 26)	DRIVER	BLANK	DRIVER	BLANK (OPTION 5)	BLANK (OPTION 5)



8 POSITION CARD CAGE

NORMAL				ENG	EMERGENCY			
1	2	3	4	5	6	7	8	9
BLANK (OPTION 26)	BLANK (OPTION 26)	BLANK (OPTION 26)	DRIVER	BLANK	DRIVER	BLANK (OPTION 5)	BLANK (OPTION 5)	BLANK (OPTION 5)



OPTION 5 - EMERGENCY SENSING (U.V., O.V., U.F., O.F.)

8 POSITION CARD CAGE

REPLACE BLANK CARD IN POSITION 5 OR 6 WITH APPROPRIATE SENSING CARD

8 POSITION CARD CAGE

REPLACE BLANK CARD IN POSITION 7, 8 OR 9 WITH APPROPRIATE SENSING CARD



OPTION 26 - NORMAL SENSING (O.V., U.F., O.F.)

8 POSITION CARD CAGE  
NOT AVAILABLE

8 POSITION CARD CAGE

REPLACE BLANK CARD IN POSITION 2 OR 3 WITH APPROPRIATE SENSING CARD

\* UNDERVOLTAGE SENSING ON NORMAL IS STANDARD

- OPTION 12C - NORMAL POSITION LIGHT (NL)  
INDICATES LOAD IS CONNECTED TO NORMAL

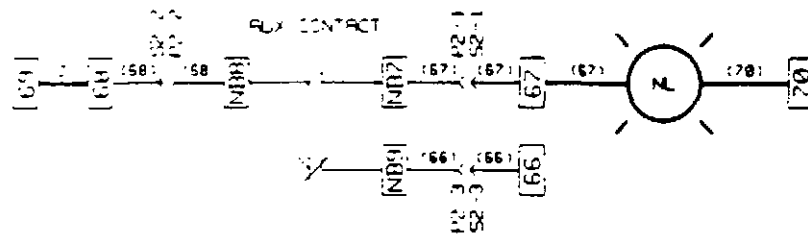

- OPTION 12D - EMERGENCY POSITION LIGHT (EL)  
INDICATES LOAD IS CONNECTED TO EMERGENCY

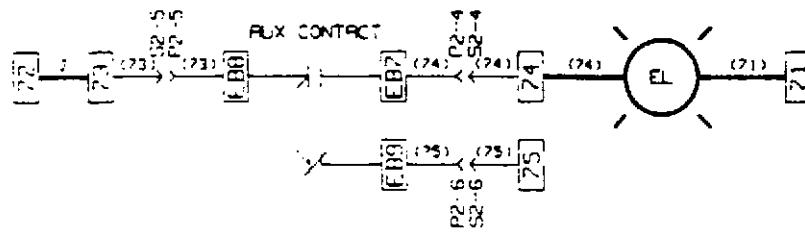

- OPTION 12E - NORMAL SOURCE LIGHT (SN)  
INDICATES NORMAL SOURCE AVAILABLE

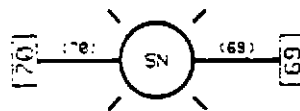

- OPTION 12F - EMERGENCY SOURCE LIGHT (SE)  
INDICATES EMERGENCY SOURCE AVAILABLE

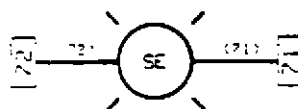



OPTION 14C - NORMAL AUXILIARY RELAY (NRA)  
 PROVIDES ADDITIONAL RELAY  
 CONTACTS ON NORMAL

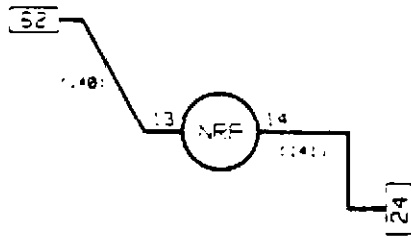

NOTE: CUSTOMER CONTACTS ARE ON RELAY SOCKET  
 SEE SOCKET DIAGRAM BELOW

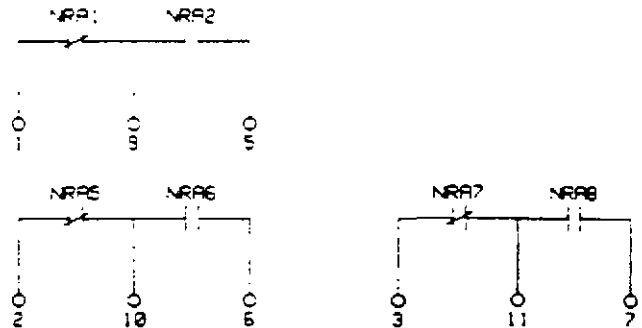

OPTION 14D - EMERGENCY AUXILIARY RELAY (ERA)  
 PROVIDES ADDITIONAL RELAY  
 CONTACTS ON EMERGENCY



NOTE: CUSTOMER CONTACTS ARE ON RELAY SOCKET  
 SEE SOCKET DIAGRAM BELOW

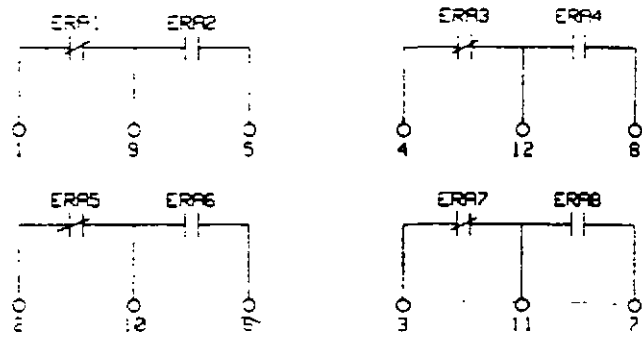

NRA - ERA SOCKET DIAGRAM

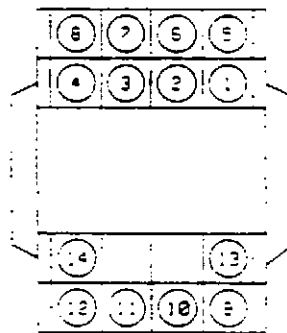

OPTION 18E - VOLTMETER

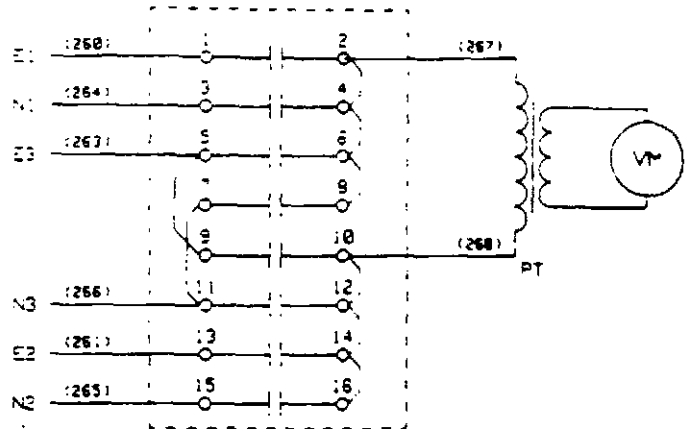
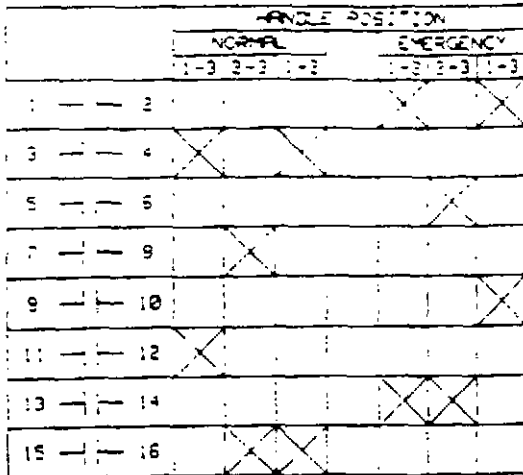

OPTION 18F - AMMETER

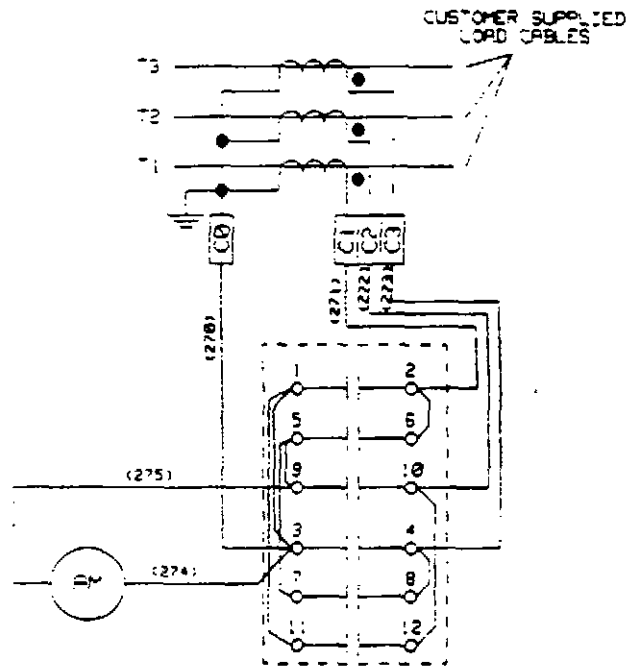
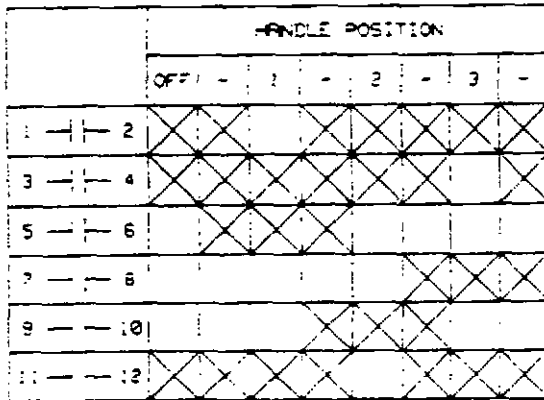

OPTION 18G - FREQUENCY METER

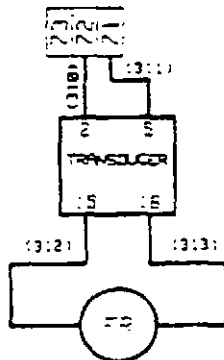

OPTION 18H - RUNNING TIME METER

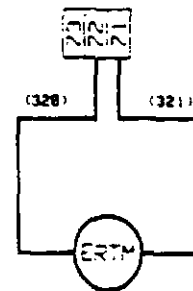

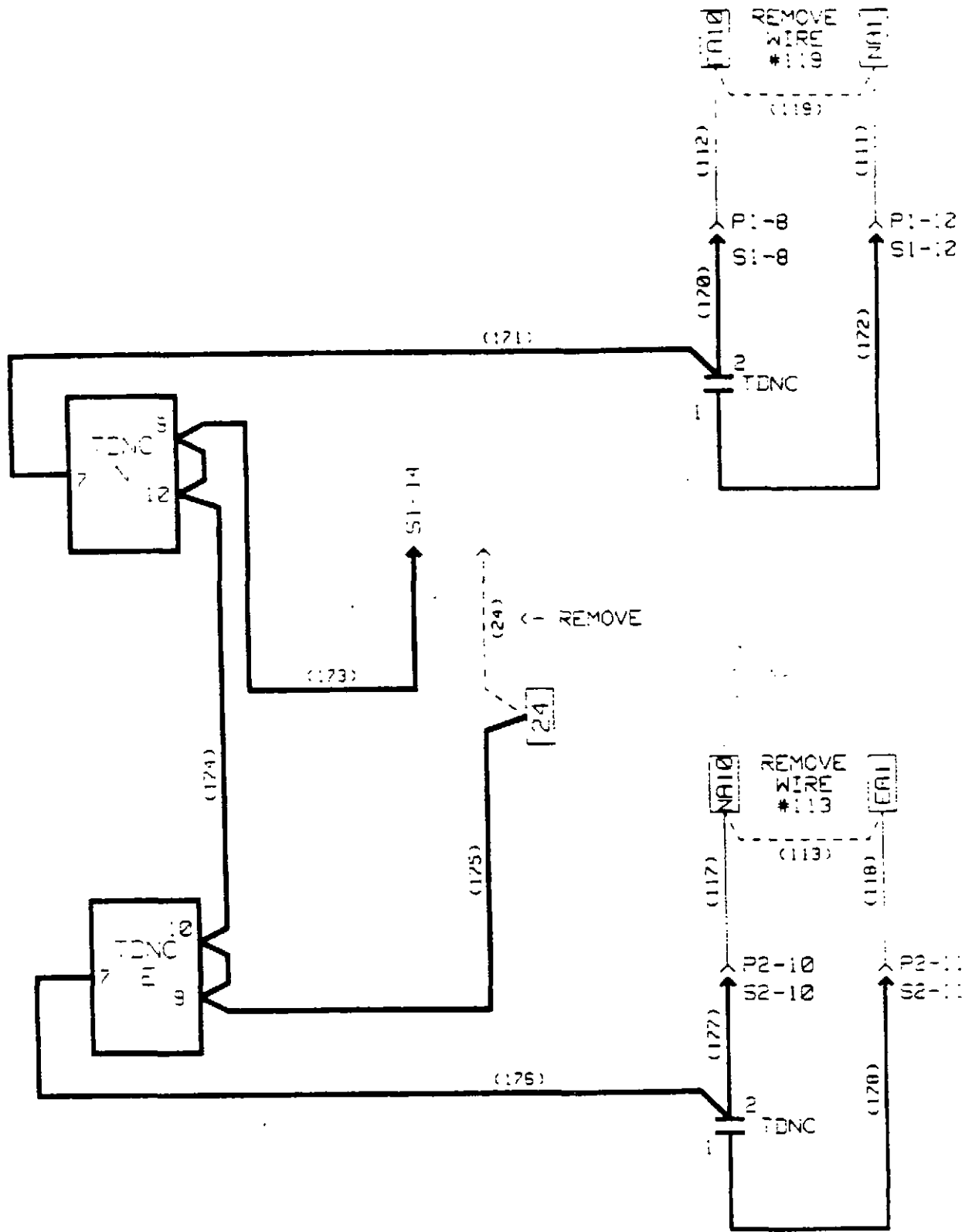

# Westinghouse SPB Non-Automatic Transfer Switch Legends for Wiring Diagram Symbols Page 8

Sym	Description
AM	Ammeter
Ex	Power Terminal, Emergency Source (x = Terminal Number)
EASx	Emergency Lockout (x = contact number)
EC	Engine Cooloff Relay Coil
ECx	Engine Cooloff Relay Contact (x = Contact Number)
EL	Emergency Position Indicator Light
EMPB	Emergency Pushbutton for MAnual Operation
EMR	Emergency Relay (for Manual Operation)
ER	Emergency Relay Coil
ERx	Emergency Relay Contact (x = Contact Number)
ERA	Emergency Auxiliary Relay
ERAx	Emergency Auxiliary Relay Contact (x = Contact Number)
ERTM	Generator Run Time Meter
ESx	Emergency Auxiliary Switch (x = Contact Number)
ET1	Emergency Transformer (Line Voltage to 120VAC - 2 windings)
ET2	Emergency Transformer (Line Voltage to 24VAC CT)
ET3	Emergency Transformer (Line Voltage to 12VAC)
ET4	Emergency Transformer (Line Voltage to 12VAC)
FPSS	Four Position Selector Switch (Option 6H)
FR	Frequency Meter
Fx	Fuse (x = fuse number)
KF	Failsafe Relay
KS	Load Shed Relay
KT	Trip Relay (Used w/Option 16)
KV	Voting Relay
MSS	Maintenance Selector Switch
NASx	Normal Lockout (x = contact number)
Nx	Power Terminal, Normal (x = Terminal Number)
NL	Normal Position Indicator Light
NMPB	Normal Pushbutton for Manual Operation
NR	Normal Relay Coil
NRx	Normal Relay Contact (x = contact number)
NRA	Normal Auxiliary Relay Coil
NRAx	Normal Auxiliary Relay Contact (x = Contact Number)
NSx	Normal Auxiliary Switch (x = Contact Number)
NT1	Normal Transformal (Line Voltage to 120VAC - 2 windings)
NT2	Normal Transformer (Line Voltage to 24VAC CT)
NT3	Normal Transformer (Line Voltage to 12VAC)
NT4	Normal Transformer (Line Voltage to 12VAC)
Px-y	Plug (x = plug number, y = terminal number)
PBEN	Bypass TDEN Pusgbutton
PBNE	Bypass TDNE Pushbutton
PBRE	Reset Emergency Breaker Pushbutton
PBRN	Reset Normal Breaker Pushbutton
PE	Plant Exerciser

# Westinghouse SPB Non-Automatic Transfer Switch Legends for Wiring Diagram Symbols Page 9

<b>Sym</b>	<b>Description</b>
PSDR	Pre-Transfer Signal Device Relay
PSDT	Pre-Transfer Signal Device Timer
PSS	Preferred Source Selector Switch
Sx-y	Socket (x = socket number, y = terminal number)
SDL	Service Disconnect Light
SDSS	Service Disconnect Selector Switch
SD	Services Disconnected Light
SE	Emergency Source Available Indicator Light
SN	Normal Source Available Indicator Light
Tx	Power Terminal, Load (x = Terminal Number)
TPB	Test Pushbutton
VM	Voltmeter

# Cutler-Hammer Beaver, PA

Automatic Transfer Switch

Type **BIHS** Wiring Diagrams

Cutler-Hammer  
Power Distribution Components Division  
One Tuscarawas Road  
Beaver, PA 15009

Copyright 1995 by Eaton/Cutler-Hammer Inc.  
All Rights Reserved

Version 1.1 8-5-91

# Cutler-Hammer Bypass/Isolation Transfer Switch Wiring Diagrams

## Directions for Use

The drawing package can be used as a point to point wiring diagram for maintenance and diagnostic purposes for Solid State Logic Bypass/Isolation Transfer Switches, 100 -1000 amperes.

This document contains the following wiring information:

- Page 1** Standard Solid State Intelligence Panel Wiring exclusive of added option functions.
- Page 2** Power Switching Panel basic wiring, 100 - 1000 amperes exclusive of added option functions.
- Page 3** Basic Power Busing scheme for the Bypass/Isolation switch with Automatic Transfer Switch
- Page 4** Auxiliary Power Panel wiring. This is the power supply for the Bypass Status Annunciator Panel, and Source/Load condition lights.
- Page 5** Automatic Transfer Switch Power wiring. This shows the interconnections between the ATS Switching Panel, the Intelligence Panel, and the Power Connections.
- Page 6** Harnesses used to supply power to the Bypass/Isolation Annunciator Panel, from the Auxiliary Power Panel, using appropriate contacts.
- Page 7** Wiring of typical attachments, and the Annunciator panel wiring.
- Pages 8 - 18** Option Wiring
- Page 19** Legend Sheet describing symbols used throughout this document.

Note: Unnumbered sheets may be added to this document on specific occasions to illustrate custom options additions per order instructions.

All Bypass/Isolation Switches will be standardly wired as indicated sheets 1 through 7. Your specific switch may be equipped with certain optional functions as noted which require additional wiring as shown on pages 8 - 18.

Note: **BOLD** lines on option wiring indicate components and wiring added to the basic wiring diagram to accomplish that specific option function.

# Cutler-Hammer Bypass/Isolation Transfer Switch

## Standard Features

### Test Selector Switch

Simulates a power failure in the logic. Will cause the Generator to start, and load to transfer to the Emergency Source.

### Undervoltage Protection on NORMAL (All phases)

Monitors the voltage on the NORMAL Source for an undervoltage condition. Should the voltage drop below a preset Dropout, the generator is started and transfer to the EMERGENCY Source takes place.

### Engine Start Contact

Contact that provides a closure to Engine Controller when the NORMAL Source fails.

### Generator Selector Switch

A three position switch (AUTO - OFF - RUN) is provided, to allow normal operation with the Automatic Transfer Switch, or to provide manual control when using the Bypass Switch.

### Logic Disconnect

Plugs provided to disconnect the logic circuitry for maintenance purposes.

### Status Indicators

A Bypass Status Annunciator Panel is provided with the following indicators:

- Normal Bypass Energized
- Normal Bypass Trip
- Emergency Bypass Energized
- Emergency Bypass Trip
- Isolated
- Isolator Trip

Standard indicators on the ATS Status Panel are:

- Normal Position Energized
- Emergency Position Energized
- Normal Source Available
- Emergency Source Available
- Load Energized

### Auxiliary Contacts

Auxiliary contacts integral to the switching devices rated at 120 VAC, 10 amps. These may be applied for customer use, and may be applied to certain customer specified options.

# BYPASS/ISOLATION SWITCH INTELLIGENCE PANEL

NOTE A

NOTE A:  
TRANSFORMERS NT3, NT4 AND  
WIRES 123, 129 USED FOR AND  
3 PHASE NORMAL SENSING

TRANSFORMERS ET3, ET4 AND  
WIRES 114, 115 USED FOR  
3 PHASE EMERGENCY SENSING  
(OPTION 5F AND/OR 5G)

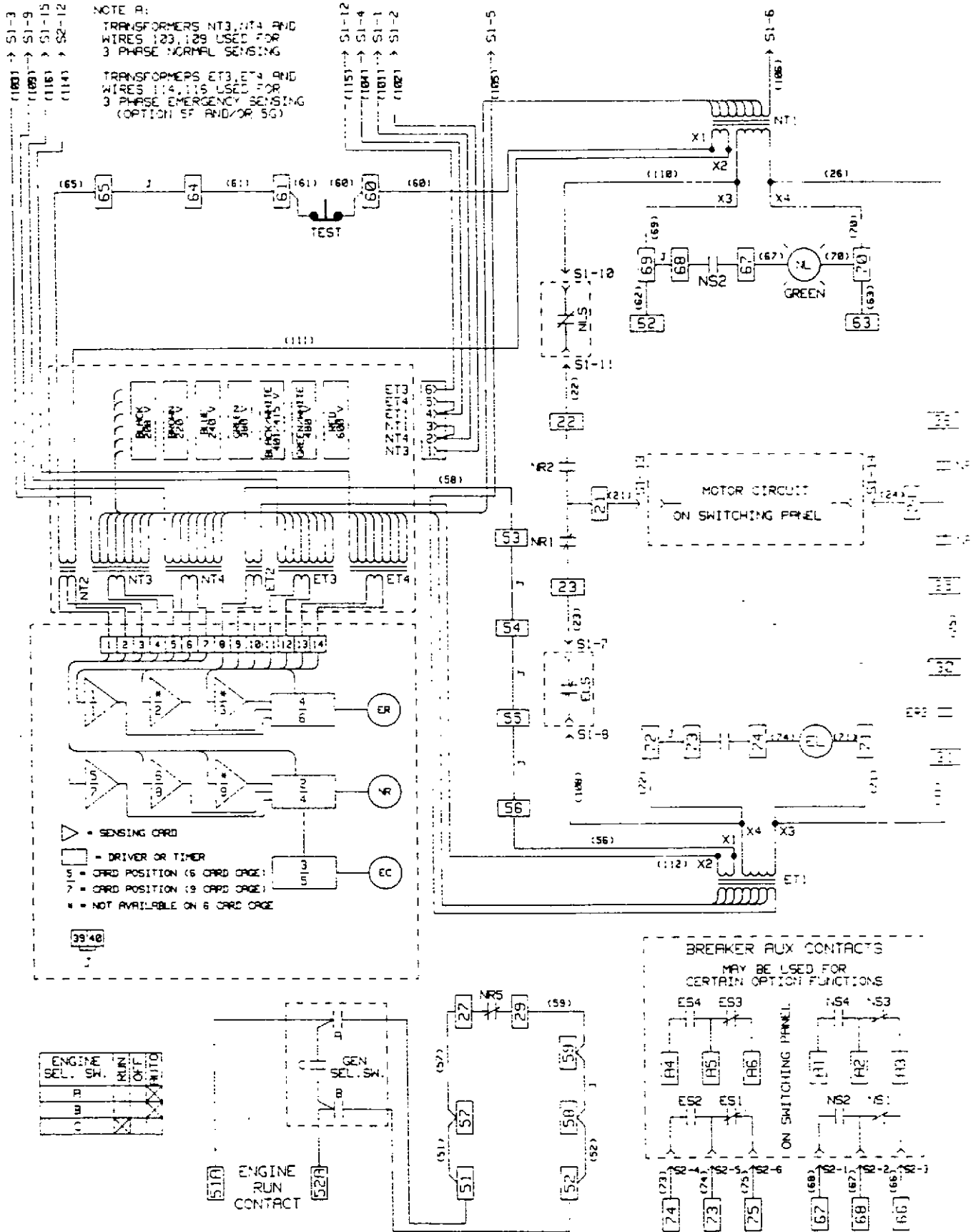



# BYPASS/ISOLATION SWITCH- POWER WIRING

NOTE: POWER CONNECTIONS AS SHOWN ARE FOR DIAGRAM PURPOSES

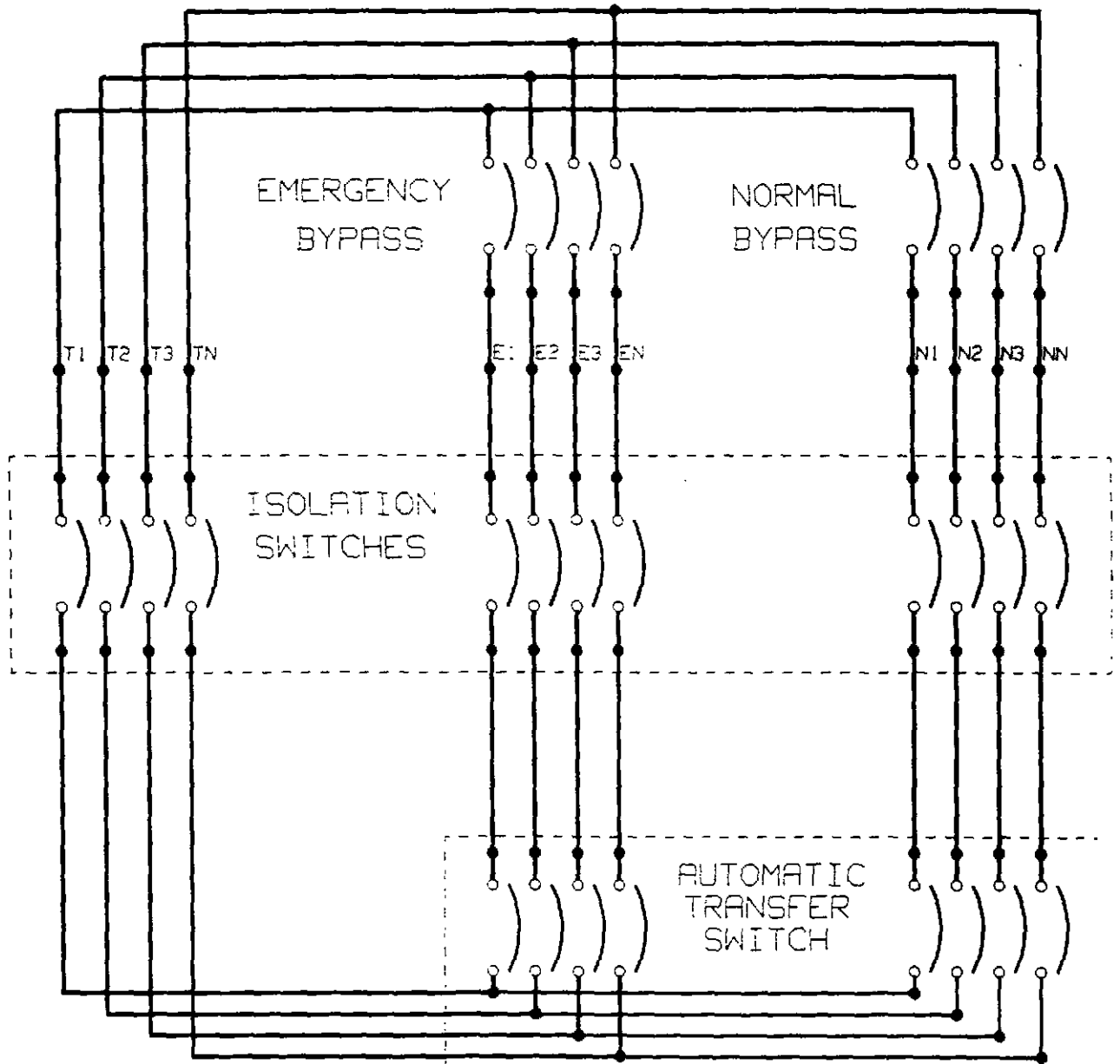

ATS UPPER PANEL CONTROL WIRING  
SHOWN ON SEPARATE SHEET

BYPASS ISOLATION TRANSFER SWITCH  
 AUXILIARY POWER PANEL

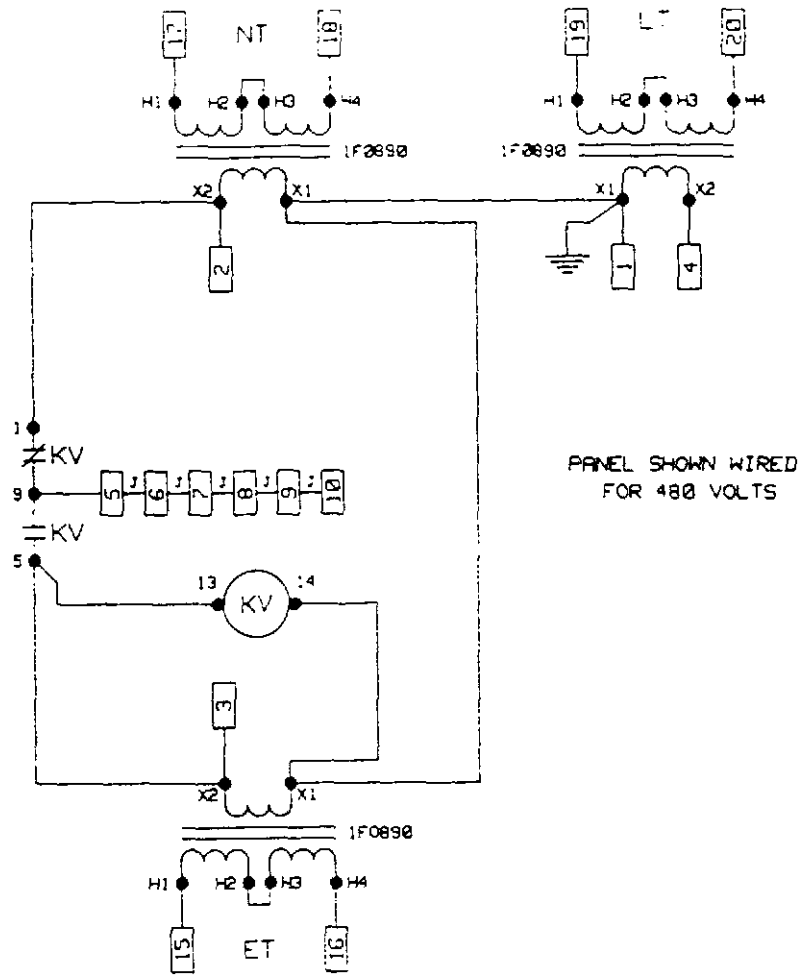

TYPICAL TRANSFORMER WIRING FOR OTHER VOLTAGES

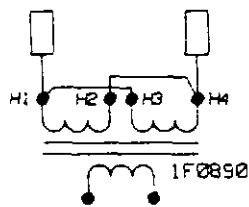

220/240

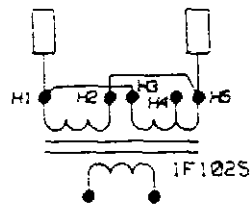

208

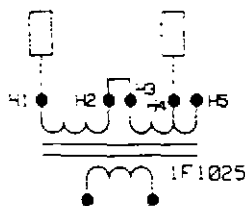

382

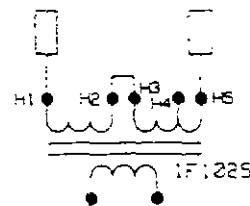

416

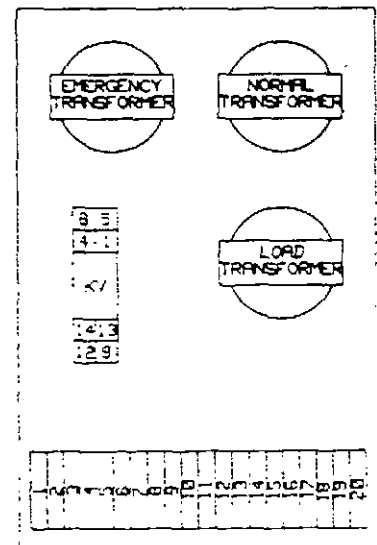

# BYPASS ISOLATION SWITCH PTS POWER HARNESS

TO  
SWITCHING  
PANEL

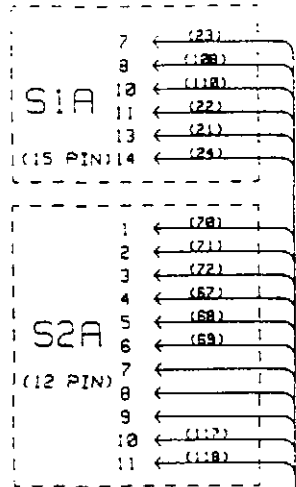

TO  
INTELLIGENCE  
PANEL

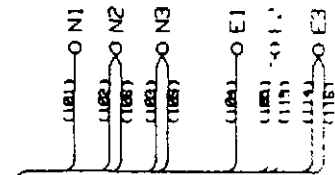
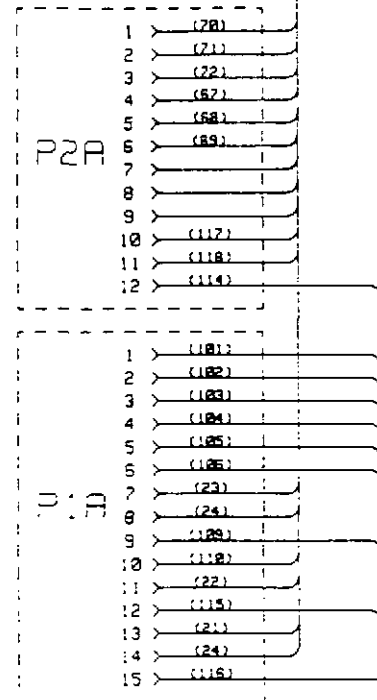

# BYPASS/ISOLATION SWITCH STATUS INDICATOR HARNESSSES

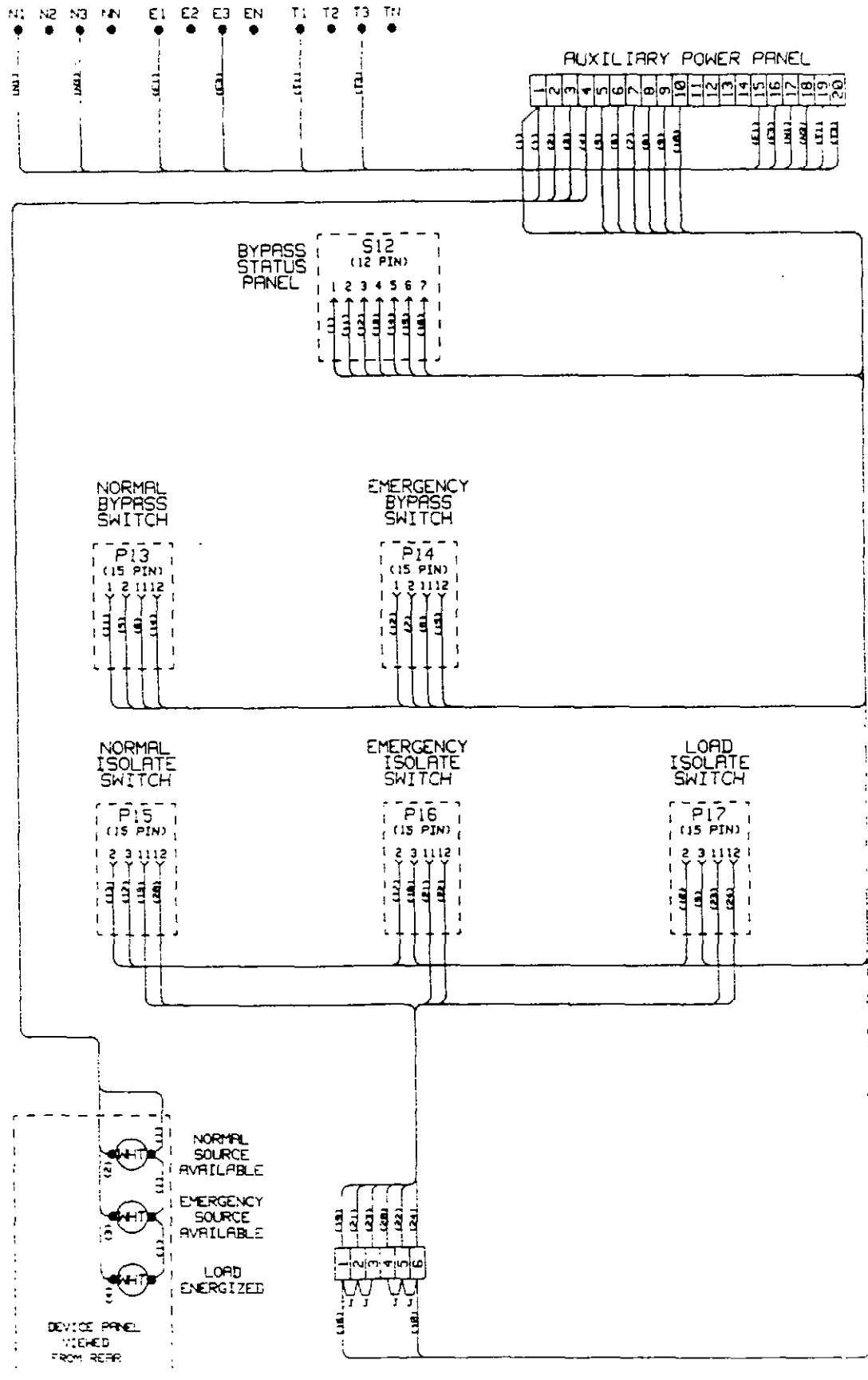

# BYPASS/ISOLATION SWITCH MISCELLANEOUS DEVICES

TYPICAL ATTACHMENT WIRING

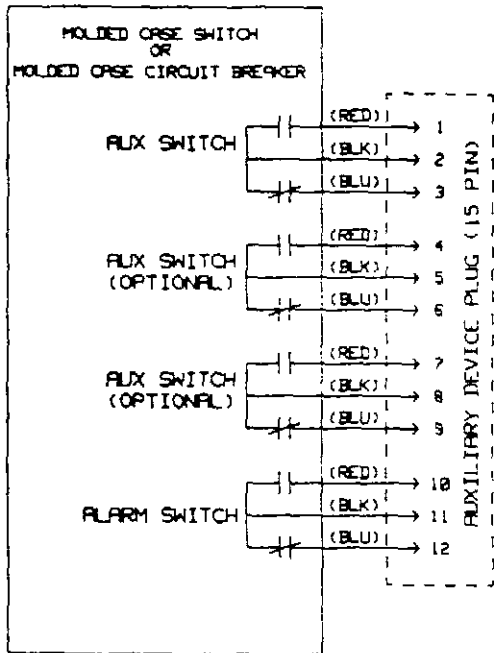

BYPASS STATUS  
ANNUNCIATOR PANEL

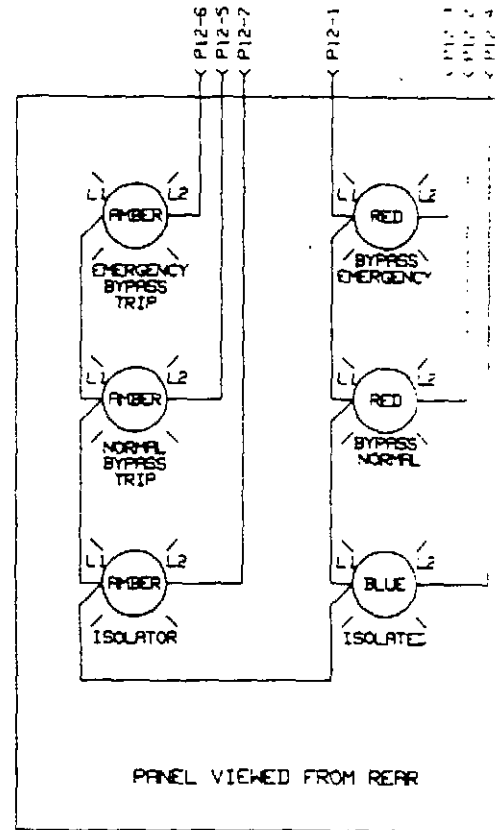



6 POSITION CARD CAGE

	NORMAL	ENG	EMERGENCY		
	2	3	4	5	6
UNDERVOLTAGE					
STD					
DRIVER					
(OPTION 3)					
BLANK					
(OPTION 4)					
DRIVER					
(OPTION 1)					
BLANK					
(OPTION 5)					
BLANK					
(OPTION 5)					



9 POSITION CARD CAGE

	NORMAL			ENG	EMERGENCY			
	2	3	4	5	6	7	8	9
UNDERVOLTAGE								
STD								
BLANK								
(OPTION 26)								
BLANK								
(OPTION 26)								
DRIVER								
(OPTION 3)								
BLANK								
(OPTION 4)								
DRIVER								
(OPTION 1)								
BLANK								
(OPTION 5)								
BLANK								
(OPTION 5)								
BLANK								
(OPTION 5)								



OPTION 1 - TIME DELAY NORMAL TO EMERGENCY (TDNE)

6 POSITION CARD CAGE

REPLACE DRIVER CARD IN POSITION 4 WITH TIMER CARD

9 POSITION CARD CAGE

REPLACE DRIVER CARD IN POSITION 6 WITH TIMER CARD



OPTION 3 - TIME DELAY EMERGENCY TO NORMAL (TDEN)

6 POSITION CARD CAGE

REPLACE DRIVER CARD IN POSITION 2 WITH TIMER CARD

9 POSITION CARD CAGE

REPLACE DRIVER CARD IN POSITION 4 WITH TIMER CARD



OPTION 4 - TIME DELAY ENGINE COOLOFF (TDEC)

6 POSITION CARD CAGE

REPLACE BLANK CARD IN POSITION 3 WITH TIMER CARD  
ADD EC RELAY TO MOTHERBOARD

9 POSITION CARD CAGE

REPLACE BLANK CARD IN POSITION 5 WITH TIMER CARD  
ADD EC RELAY TO MOTHERBOARD

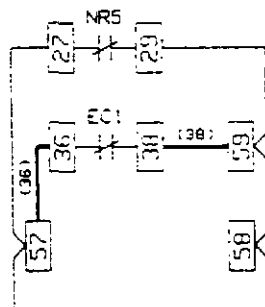

OPTION 4 ONLY

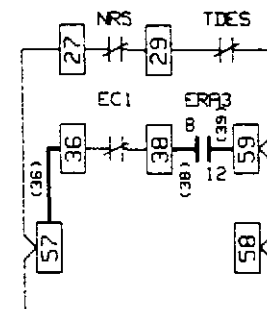

OPTION 4 WITH 2 \*\*  
\*\* REQUIRES OPTION 14D



OPTION 5 - EMERGENCY SENSING (UV,OV,UF,OF)

6 POSITION CARD CAGE

REPLACE BLANK CARD IN POSITION 5 OR 6 WITH APPROPRIATE SENSING CARD

9 POSITION CARD CAGE

REPLACE BLANK CARD IN POSITION 7,8 OR 9 WITH APPROPRIATE SENSING CARD



OPTION 25 - NORMAL SENSING (OV,UF,OF)

6 POSITION CARD CAGE

NOT AVAILABLE

9 POSITION CARD CAGE

REPLACE BLANK CARD IN POSITION 2 OR 3 WITH APPROPRIATE SENSING CARD

\* UNDERVOLTAGE SENSING ON NORMAL IS STANDARD

OPTION 2 - TIME DELAY ENGINE START (TDES)

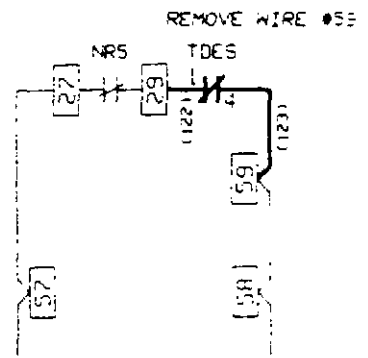
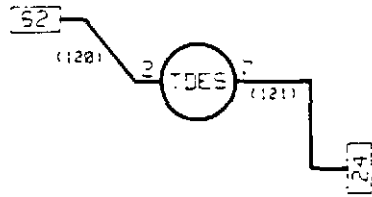

OPTION 6D - TEST SELECTOR SWITCH (TSS)

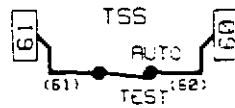

REPLACES STANDARD TEST PUSHBUTTON

OPTION 6H - FOUR POSITION SELECTOR SWITCH (FPSS)

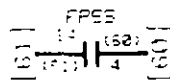

REPLACES STANDARD TEST PUSHBUTTON

FPSS	JL9 10T	JL11 12T	JL14 14T	JL15 16T	JL17 10T
TEST	X	X	X	X	X
AUTO	X	X	X	X	X
OFF	X	X	X	X	X
ENG. RUN	X	X	X	X	X

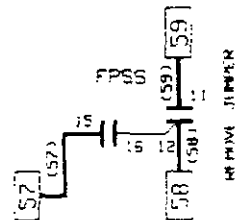
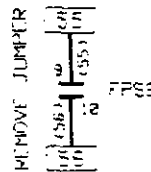
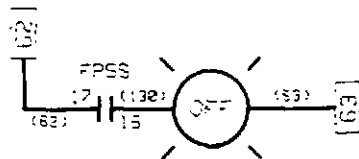

OPTION 8C - BYPASS TDEN TIMER (PBEN)

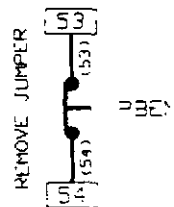

OPTION 8D - BYPASS TDNE TIMER (PBNE)

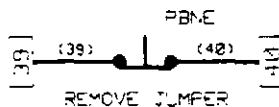

- OPTION 23C - PLANT EXERCISER  
RUN ENGINE AT SPECIFIED TIME - NO LOAD

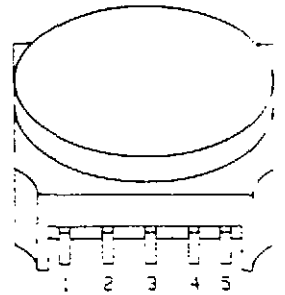

PLANT EXERCISER  
TERMINAL LAYOUT

- OPTION 23D - PLANT EXERCISER  
RUN ENGINE AT SPECIFIED TIME - LOAD

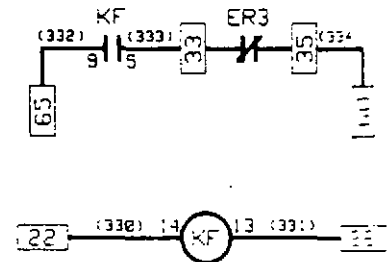
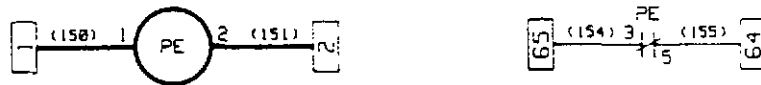

- OPTION 23I = 23D W/FAILSAFE

- OPTION 23J = 23G W/FAILSAFE



FAILSAFE CIRCUIT

- OPTION 23G - PLANT EXERCISER  
RUN ENGINE AT SPECIFIED TIME - LOAD OR NO LOAD  
(SWITCH SELECTABLE)



		ENGINE RUN	BYPASS
1	2	X	
5	6		X
7	8	X	X
9	10	X	
11	12		

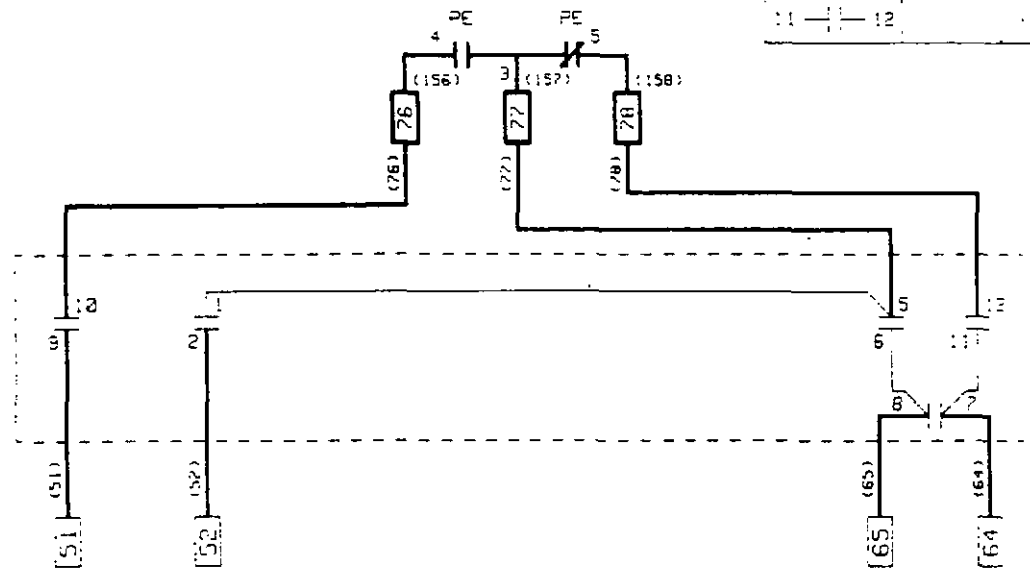

REMOVE JUMPER 64-65

- OPTION 12C - NORMAL POSITION LIGHT (NL)  
INDICATES LOAD IS CONNECTED TO NORMAL

SUPPLIED AS STANDARD

- OPTION 12D - EMERGENCY POSITION LIGHT (EL)  
INDICATES LOAD IS CONNECTED TO EMERGENCY

SUPPLIED AS STANDARD

- OPTION 12G - NORMAL SOURCE LIGHT (SN)  
INDICATES NORMAL SOURCE AVAILABLE

SUPPLIED AS STANDARD

- OPTION 12H - EMERGENCY SOURCE LIGHT (SE)  
INDICATES EMERGENCY SOURCE AVAILABLE

SUPPLIED AS STANDARD

- OPTION 12L - NORMAL TRIPPED INDICATOR (TN)  
INDICATES OVERLOAD TRIP ON NORMAL

NOTE: ONLY AVAILABLE WHEN  
OPTION 11F IS SUPPLIED

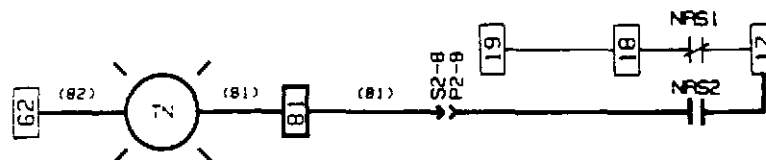

- OPTION 12M - EMERGENCY TRIPPED INDICATOR (TE)  
INDICATES OVERLOAD TRIP ON EMERGENCY

NOTE: ONLY AVAILABLE WHEN  
OPTION 11F IS SUPPLIED

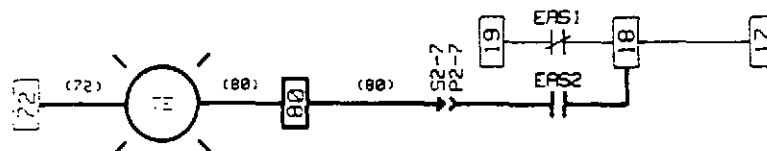



OPTION 14C - NORMAL AUXILIARY RELAY (NRA)  
PROVIDES ADDITIONAL RELAY CONTACTS ON NORMAL

NOTE: CUSTOMER CONTACTS ARE ON RELAY SOCKET  
SEE SOCKET DIAGRAM BELOW

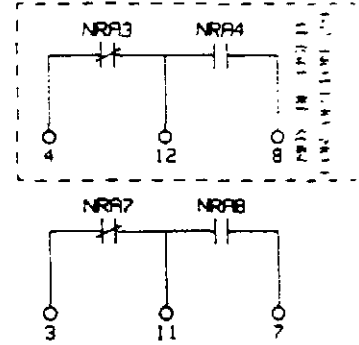
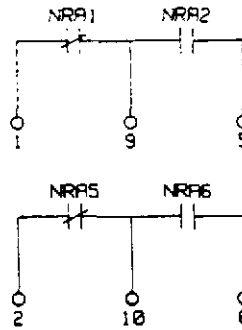
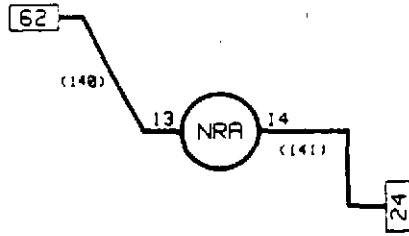

OPTION 14D - EMERGENCY AUXILIARY RELAY (ERA)  
PROVIDES ADDITIONAL RELAY CONTACTS ON EMERGENCY

NOTE: CUSTOMER CONTACTS ARE ON RELAY SOCKET  
SEE SOCKET DIAGRAM BELOW

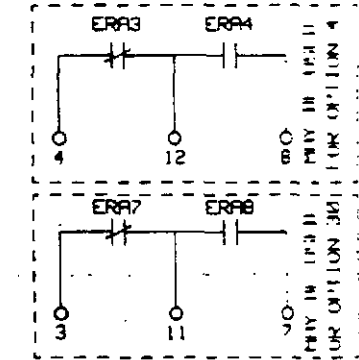
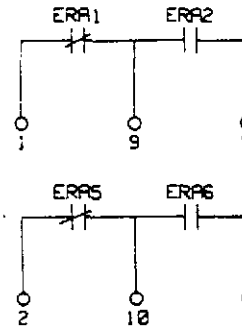

NRA - ERA SOCKET DIAGRAM

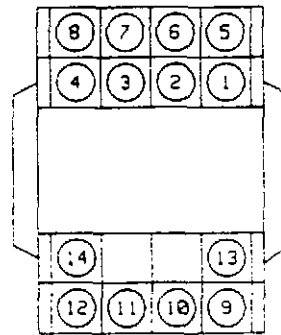

OPTION 23C - PLANT EXERCISER  
 RUN ENGINE AT SPECIFIED TIME  
 (NO LOAD)

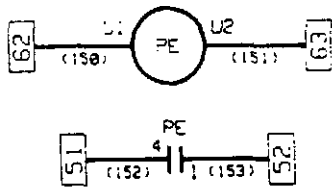

PE TERMINAL BLOCK

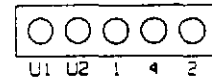

OPTION 23I = 23D W/FAILSAFE  
 OPTION 23J = 23G W/FAILSAFE

OPTION 23D - PLANT EXERCISER  
 RUN ENGINE AT SPECIFIED TIME  
 (LOAD)

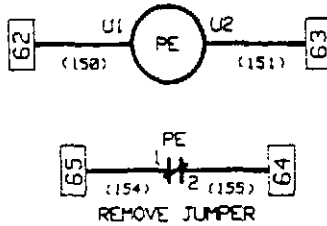

FAILSAFE CIRCUIT

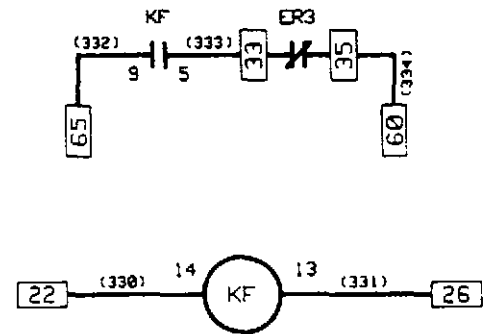

OPTION 23G - PLANT EXERCISER  
 RUN ENGINE AT SPECIFIED TIME  
 (SWITCH SELECTABLE  
 LOAD OR NO LOAD)

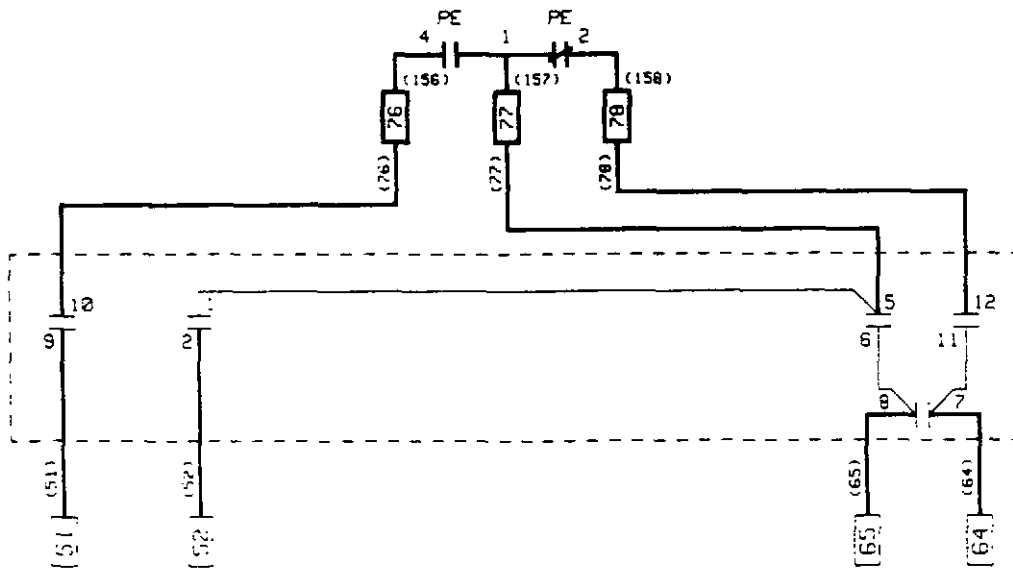

	ENGINE RUN	BYPASS (154)
1 - 2	X	
5 - 6		
7 - 8	X	X
9 - 10	X	X
11 - 12		X

REMOVE JUMPER 64-65

OPTION 28A - INTELLIGENCE CIRCUIT FUSES  
 FUSES NON-ESSENTIAL CIRCUITRY ONLY

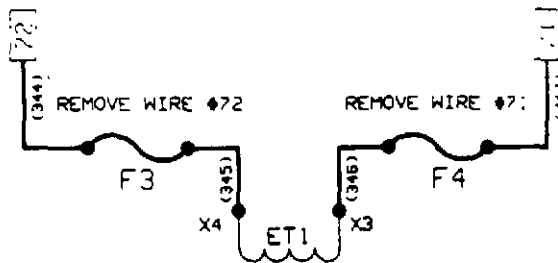
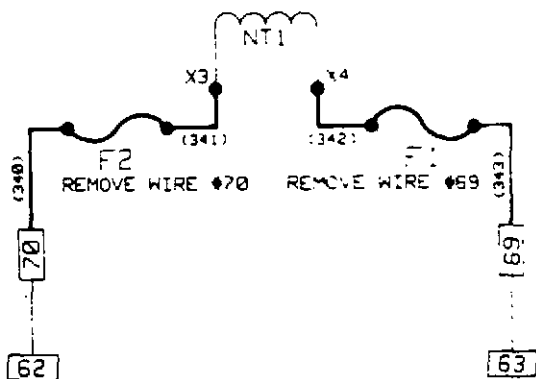

OPTION 33A - SHUNT TRIP  
 (NORMAL)

OPTION 33B - SHUNT TRIP  
 (EMERGENCY)

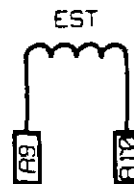
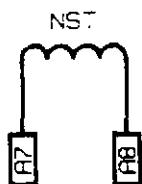

**OPTION 32 - TIME DELAY CRANK LIMITER (TDCL)**  
 INTERRUPTS ENGINE START CIRCUIT IF VOLTAGE DOES NOT APPEAR WITHIN A PRESELECTED TIME

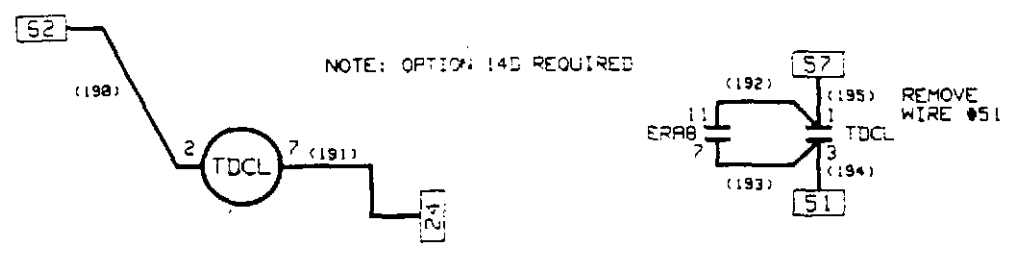

**OPTION 32A - TIME DELAY NEUTRAL (TDNC)**  
 PROVIDES A TIME DELAY IN THE NEUTRAL POSITION WHEN THE LOAD IS TRANSFERRED IN EITHER DIRECTION TO PREVENT EXCESSIVE INRUSH CURRENTS DUE TO OUT-OF-PHASE SWITCHING OF INDUCTIVE LOADS

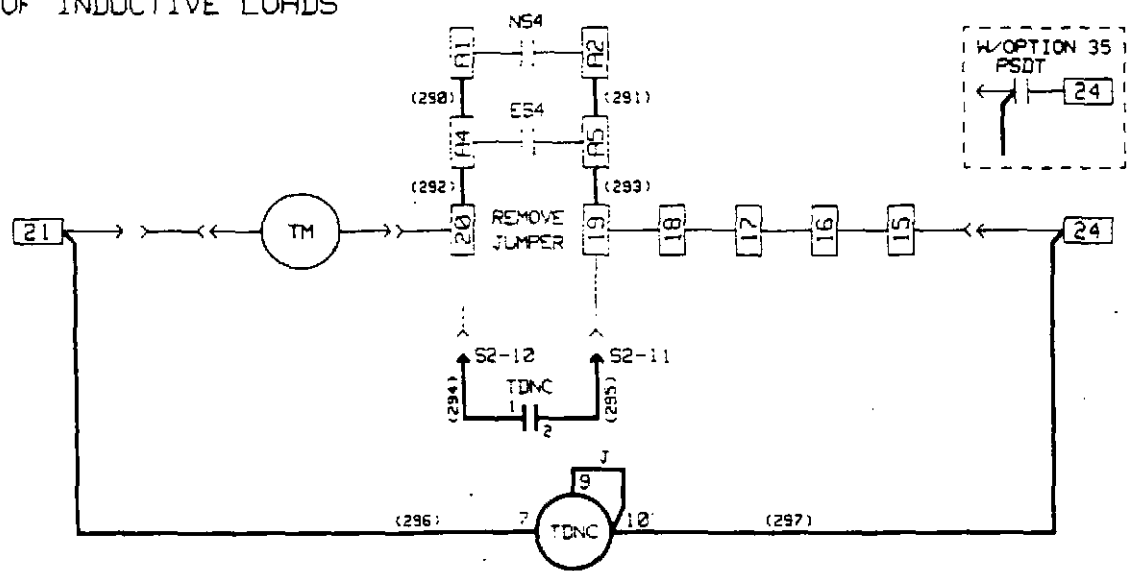

**OPTION 35A - PRETRANSFER SIGNAL DEVICE (PSD)**  
 RELAY CONTACTS CHANGE STATE PRIOR TO TRANSFER WITH PRESET TIME DELAY

