

IQ GENERATOR

LINE METERING SYSTEM USER'S MANUAL

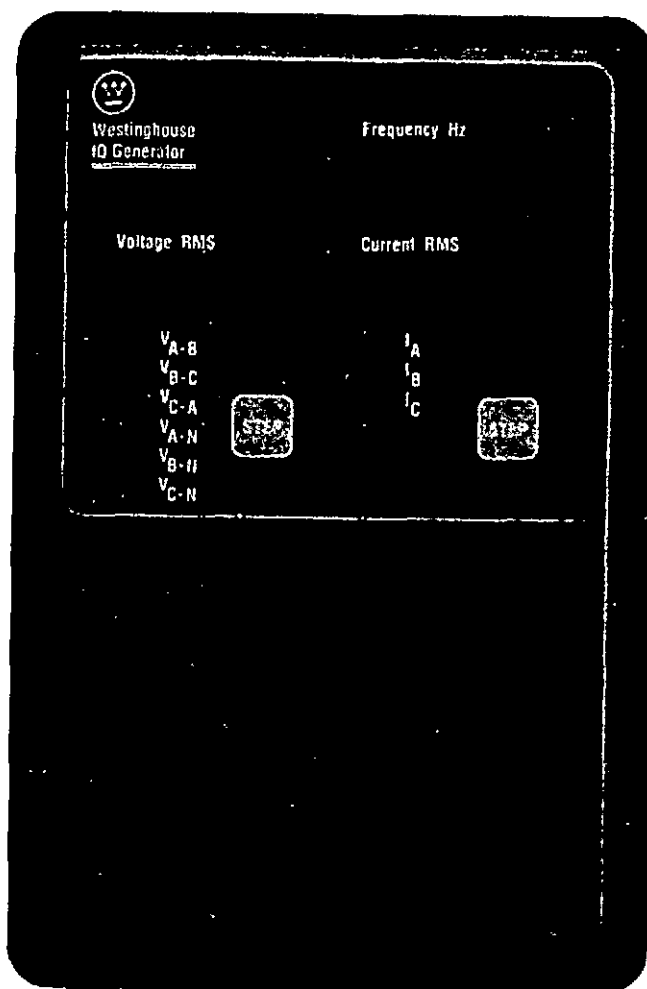

Instructions for Three-Phase Power Supply Module



I.L. 17285B

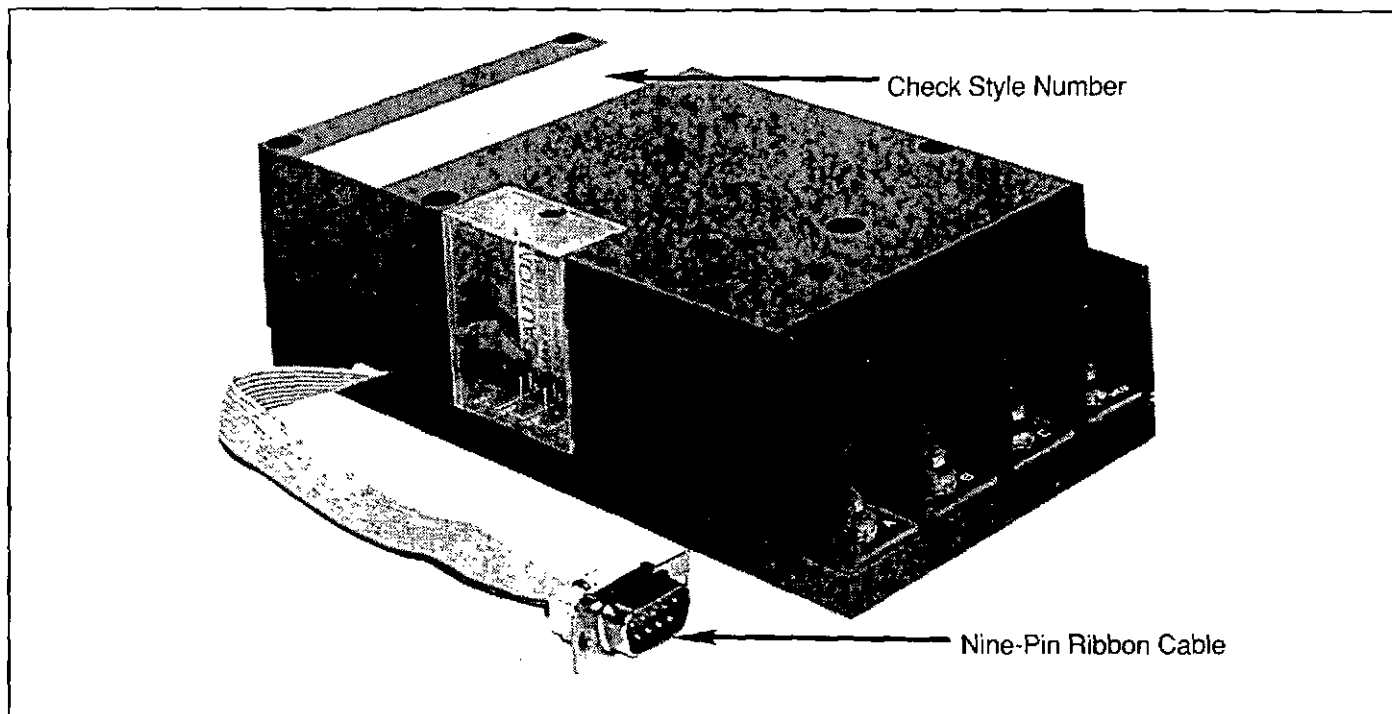

Fig. 1 Three-Phase Power Supply Module

THE MODULE

Three-phase power supply modules are offered in two styles (9966D75G01 and G02) for the specific applications shown in Table I. If a power module is used with an IQ metering device other than as shown, equipment damage will result. The appropriate power module will permit an IQ DATA, IQ GENERATOR, IQ DATA PLUS or IQ DATA PLUS II to be powered from the 50 or 60 hertz lines being monitored. The three-phase power module is used in lieu of a separate 120 or 240 VAC power supply.

VOLTAGE SWITCH

The difference between style 9966D75G01 and 9966D75G02 is the setting of the voltage switch located on the printed circuit board. See Figures 2 and 4. This switch position determines the voltage supplied to the IQ

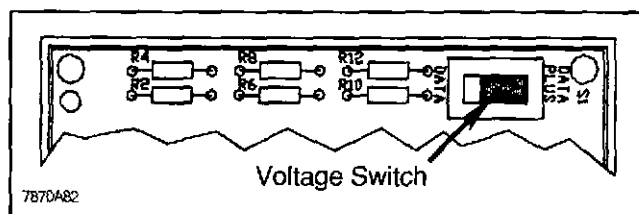

Fig. 2 Location of Voltage Switch

device via the 9-pin ribbon cable. Modules are marked with the style number corresponding to the switch position. Style number 9966D75G01 denotes the switch in the "Data Plus" position for use with the IQ Data Plus/Data Plus II/Data Plus II HV. Style number 9966D75G02 denotes the switch in the "Data" position for use with the IQ Data or IQ Generator.

TABLE I — MODULE APPLICATIONS

Style No. 9966D75G01 is a replacement for style 5281C55G02 power module.			Style No. 9966D75G02 is a replacement for style 5281C55G03 power module.		
Style No. 9966D75G01 may also be used with:			Style No. 9966D75G02 may also be used with:		
<u>IQ Metering Device</u>	<u>Style No. with Power Module Originally</u>		<u>IQ Metering Device</u>	<u>Style No. with Power Module Originally</u>	<u>Style No. w/o Power Module Originally</u>
IQ DATA PLUS	9966D38G01		IQ DATA	2D78533G03	2D78533G01
IQ DATA PLUS II	2D78522G01		IQ GENERATOR	2D78533G04	2D78533G02
IQ DATA PLUS II HV	2D78544G01				

THREE-PHASE POWER SUPPLY MODULE

I.L. 17285B

7870A82

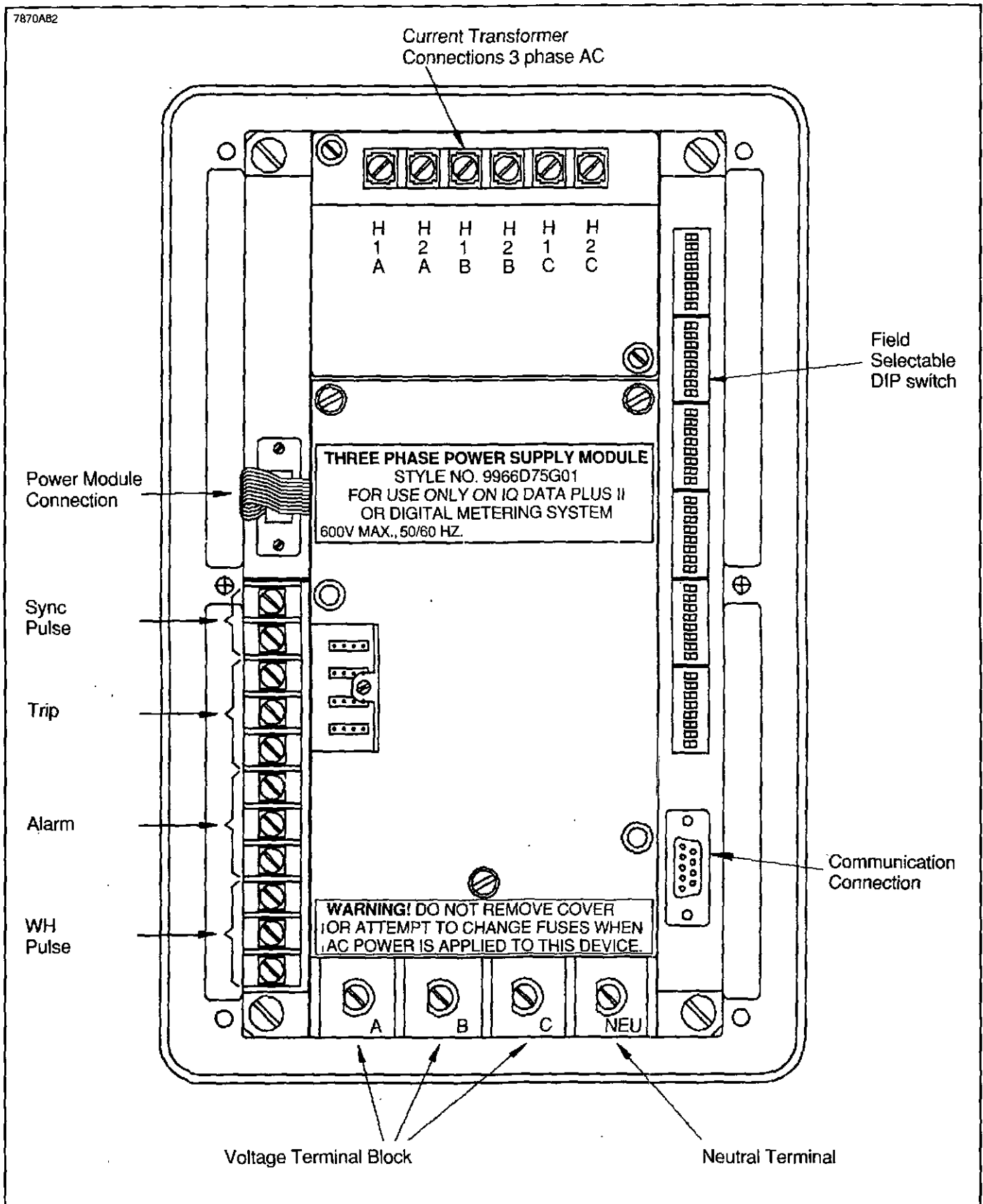

Fig. 6 IQ DATA PLUS II with Three-Phase Power Supply Module Installed

Effective 9/91
Supersedes 17285A (4/91)

Westinghouse Electric Corporation
Electrical Components Division
875 Greentree Road
Pittsburgh, PA 15220

Printed in USA

NOTE

All possible contingencies which may arise during installation, operation, or maintenance, and all details and variations of this equipment do not purport to be covered by these instructions. If further information is desired by purchaser regarding his particular installation, operation or maintenance of his equipment, the local Westinghouse Electric Corporation representative should be contacted.

Westinghouse Electric Corporation
Distribution and Control Business Unit
Electrical Components Division
Pittsburgh, PA 15220

TABLE OF CONTENTS

Sec/Par	Title	Page	Sec/Par	Title	Page
1	Introduction		4.1.3	Optional Power Module	13
1.0	General	4	4.1.4	Voltage Selector Jumper	13
1.1	Features and Options	4	4.2	Wiring	14
1.2	Required External Hardware	4	4.3	DIP Switch Settings	18
1.3	Use of Manual	5	4.4	Initial Startup	18
1.4	Level of Repair	5	4.4.1	Before Power Application	18
2	Hardware Description		4.4.2	Initial Power Application	18
2.0	General	6	5	Application Considerations	
2.1	Hardware Description	6	5.0	General	20
2.1.1	Operator Panel	7	5.1	DIP Switch Settings	20
2.1.2	Rear Access Area	7	5.1.1	Current Transformer Ratio	20
2.1.3	External Hardware	9	5.1.2	Line Frequency	20
2.2	Specifications	9	5.1.3	Potential Transformer's Ratio	21
3	Operator Panel		5.1.4	3 Wire/4 Wire Line	21
3.0	Introduction	10	5.1.5	AC Line Voltage	21
3.1	Pushbuttons	10	6	Theory of Operation	
3.2	LEDs	10	6.0	General	22
3.2.1	Menu LEDs	10	6.1	Basic Block	22
3.3	Display Window	11	7	Maintenance	
4	Installation and Startup		7.0	General	23
4.0	Introduction	12	7.1	Troubleshooting	23
4.1	Panel Preparation	12	7.1.1	Initial Startup	23
4.1.1	Cutout, Clearances	12	7.1.2	Operational	24
4.1.2	Mounting	12	7.2	Unit Replacement	24

LIST OF FIGURES

Figure	Title	Page	Figure	Title	Page
1.1	IQ Generator	4	4.2	Optional Power Module	13
2.1A	Rear Access Area	6	4.3	Fusing for 3-Phase Power Module	14
2.1B	IQ Generator with 3-Phase Power Module ..	7	4.4	Wiring Diagrams	15-17
2.2	Dimensions	8	4.5	DIP Switches	18
3.1	Operator Panel	10	4.6	DIP Switch - Side View	18
4.1	Chassis Cutout Dimensions	12	6.1	IQ Data Basic Block	22

LIST OF TABLES

Table	Title	Page	Table	Title	Page
1.A	IQ Generator Features and Benefits	5	4.A	IQ Generator Installation Record Sheet	19
1.B	Communication Arrangements	5	5.A	CT Ratio Settings	20
2.A	General Specifications	8	5.B	PT Ratio Settings	21
2.B	Metering Specifications	9	7.A	Initial Power-On Troubleshooting	23
3.A	Metered Values	11	7.B	Operational Troubleshooting	24

QUICK LIST FOR IQ GENERATOR INSTALLATION

It is suggested that you thoroughly familiarize yourself with the IQ Generator User's Manual before attempting installation. This list should be used to assist you.

1. The first thing to check on the IQ Generator is that the voltage selector jumper is shorting at the correct level. Each product is shipped from the factory at 120 volts.

2. Using the technical manual, pages 18 and 19, set the DIP switches on the back of the IQ Generator at the desired values (CT ratio, PT ratio, nominal line voltage).
3. Connect the power leads to the voltage inputs of the IQ Generator — directly from the line if 600 volts or below, from PT's for up to 14.4 KV.
4. Connect CT inputs to the CT terminals of the IQ Generator. Be extremely careful to connect the inputs correctly and to line up the phases with the voltage.
5. If not using a 3-phase Power Module, then verify that

jumpers are installed correctly for your application (see Paragraph 2.1.2, item 3, page 7). Connect the 120/240 VAC control power to the unit at terminals 7 and 10. When DIP switches have been verified, apply control power to the unit.

6. Again be sure that the voltage jumper is in the correct position. Power up the unit. If the unit does not power up or if one or more phases are reading incorrect voltage, check the fuses located just above the voltage inputs inside the cover. The fuses should sit comfortably in both clips. Possible problems are blown fuses or fuses that have shaken loose in transit.

7. If you think a problem exists, check the voltage and current readings with hand-held meters. If they are correct, the unit should be operating correctly. If an LED is not functioning, return the device to the factory for repairs. **If a fuse is burned out in the 3-phase Power Module, replace it with Buss Type KTK-R-3/4 or equivalent.**

IMPORTANT

Areas in this manual shaded in gray (■) pertain only to those units which operate with the optional 3-phase Power Module (IQ Generator style number 2D78533G04). If your unit does not have this option, please skip these shaded areas.

■ Shaded area designates information that replaces or supplements applications using the 3-phase Power Module.

Section 1

INTRODUCTION

1.0 General — The IQ Generator is a microprocessor-based, self-contained, door-mounted device designed to both monitor and display electrical parameters. (See Figure 1.1)

The electrical parameters it meters are:

- AC line current (each phase)
- AC line to line voltage (all three)
- AC line to neutral voltage (four-wire systems — all three)
- Frequency

Voltage may be directly monitored on 3-phase AC lines within a range of 120 to 600 VAC nominal without external potential transformers and within a range above 600 VAC to 14.4KV with external potential transformers.

Current monitoring is through external current transformers with ratios between 25/5 to 5000/5.

Typical applications for the IQ Generator are:

- Engine generator sets
- Transformer feeder circuits
- Branch circuits
- Motor starters
- 3-phase electrical loads

The unit will auto-range all monitored values displayed on the screen by means of a floating decimal point.

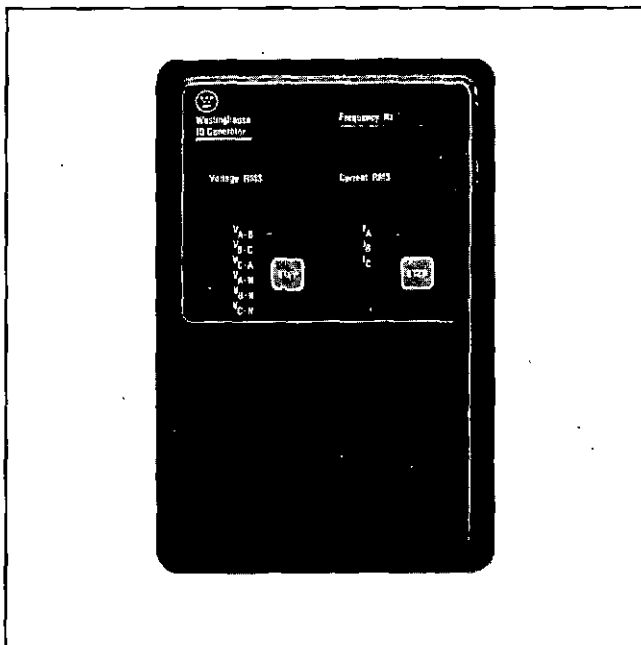

Figure 1.1 — IQ Generator

The program directing the monitoring function is permanently stored in the IQ Generator, and so there is no need to reload programs after an AC power loss.

The unit's monitoring functions are preprogrammed in the form of software supplied as standard and resident in the IQ Generator microprocessor.

The Operator Panel, which makes up the unit's front face, supports three Display Windows which visually indicate the actual value of the metered items selected for display.

The IQ Generator is available in two different models. One style (2D78533G02) is powered by separate 120 or 240 VAC control power. The second model (2D78533G04) is packaged with a three-phase Power Module. Power for this device is derived from the line being monitored.

Since the IQ Generator has only two models and very few external options, individualizing for an application is performed in the field by the user/OEM. Users choose and enter the specifications for the individual setpoints by setting a series of DIP switches. No specialized programming language is necessary.

1.1 Features and Options — Since the IQ Generator is a standardized package, there are very few external options. The options are:

- A 36-inch Extension Cable which allows removal of the 3-phase Voltage Power Module from the chassis for separate mounting
- A Communications Module (PONI Card)
See IL 17158A

The IQ Generator is capable of carrying on external data exchanges with a computer by means of a Communication Module. Electrical operating data supplied over a two-wire communication link will support plant energy management systems. This module can be added at any time.

1.2 Required External Hardware — In all instances, it is recommended that the IQ Generator use 3 user-supplied external current transformers, with 5 amp secondaries, in order to carry out metering functions involving current. In retrofit cases where only 2 CT's are provided, see the sample wiring diagrams in Figures 4.4A and 4.4B.

These may be chosen from a wide range of ratios, as is indicated in Table 5.A on page 20.

For applications in which the monitored AC line is 600 VAC, or less, **no external potential transformers are required**. In those cases where the monitored AC supply line exceeds 600 VAC, user-supplied potential transformers are required to step down the voltage to match the maximum allowable voltage permitted by the unit. See Table 5.B (page 21) for the voltage ranges the IQ Generator can monitor.

The standard unit requires 120/240 VAC control power to operate. See Figure 2.1A (page 6). The unit mounted with the three-phase Power Module draws its power from the line it is monitoring.

1.3 Use of Manual — This manual is designed for use during installation and troubleshooting and, if necessary, unit replacement. It also has information of specific importance for the user's application engineer who is planning the overall system and who is determining the setpoint values for a specific IQ Generator application.

The manual is broad enough in scope to form the basis of new employee familiarization, refresher training sessions, and on-going maintenance.

It is strongly advised that the application engineer carefully read Sections 2 thru 5 before producing the application's wiring plan drawings and filling out the Setpoint Record Sheet. Installation teams should carefully read all of Section 4 **before** starting final installation. Maintenance personnel should be familiar with Section 7 before attempting to service the IQ Generator.

1.4 Level of Repair — This manual is written with the assumption that only unit-level troubleshooting will be performed. If the cause of malfunction is traced to an IQ Generator, the unit should be replaced with a spare. The malfunctioning unit should then be returned to Westinghouse for factory repairs.

Table 1.A

IQ GENERATOR FEATURES AND BENEFITS

Feature	Benefit
<ul style="list-style-type: none"> • Microprocessor-based control • Two models • Simplified programming • Standard cutout 	<ul style="list-style-type: none"> • Reliable service without the need for numerous external measuring instruments. • Ease of purchasing, stocking • In many cases eliminates external transformers • Simplified wiring • No special languages to learn • One hole to cut • Interchangeability with IQ Data Plus II, IQ Data

Table 1.B

COMMUNICATION ARRANGEMENTS

Feature	Benefit
<ul style="list-style-type: none"> • Communication to an IBM PC (or clone) personal computer. This computer acts as the master and can also be used as the interface to other microprocessor-based devices. • Communications via RS232C to other microprocessor-based products or phone modems. 	<ul style="list-style-type: none"> • A Local Area Network, Westinghouse INCOM, is formed by 2 or more IQ Generators connecting to a personal computer via a shared twisted pair of wires. The personal computer acts as a master. In this arrangement the PONI Communication Module is mounted on each IQ Generator. A CONI Communication Card is used in an expansion slot of the personal computer. A standardized software package is provided with the CONI Card for data collection and storage. • Using INCOM, 2 or more IQ Generators (or other IQ products), each with a PONI Communication Module, can be connected to the two wire network to transmit data to a single Translator Module. This module converts INCOM formatted messages to RS232C for use with other RS232C compatible devices. No software is provided in this case.

Section 2

HARDWARE DESCRIPTION

2.0 General — The purpose of this Section is to familiarize the reader with the IQ Generator hardware, its nomenclature, and to list the specifications of the unit.

2.1 Hardware Description — The IQ Generator is designed to be mounted through a cutout in a panel. (This will generally be a cabinet's face or door.)

The description here is divided into the following:

- Operator Panel (Par. 2.1.1)
- Rear access area (Par. 2.1.2)
- External hardware (Par. 2.1.3)

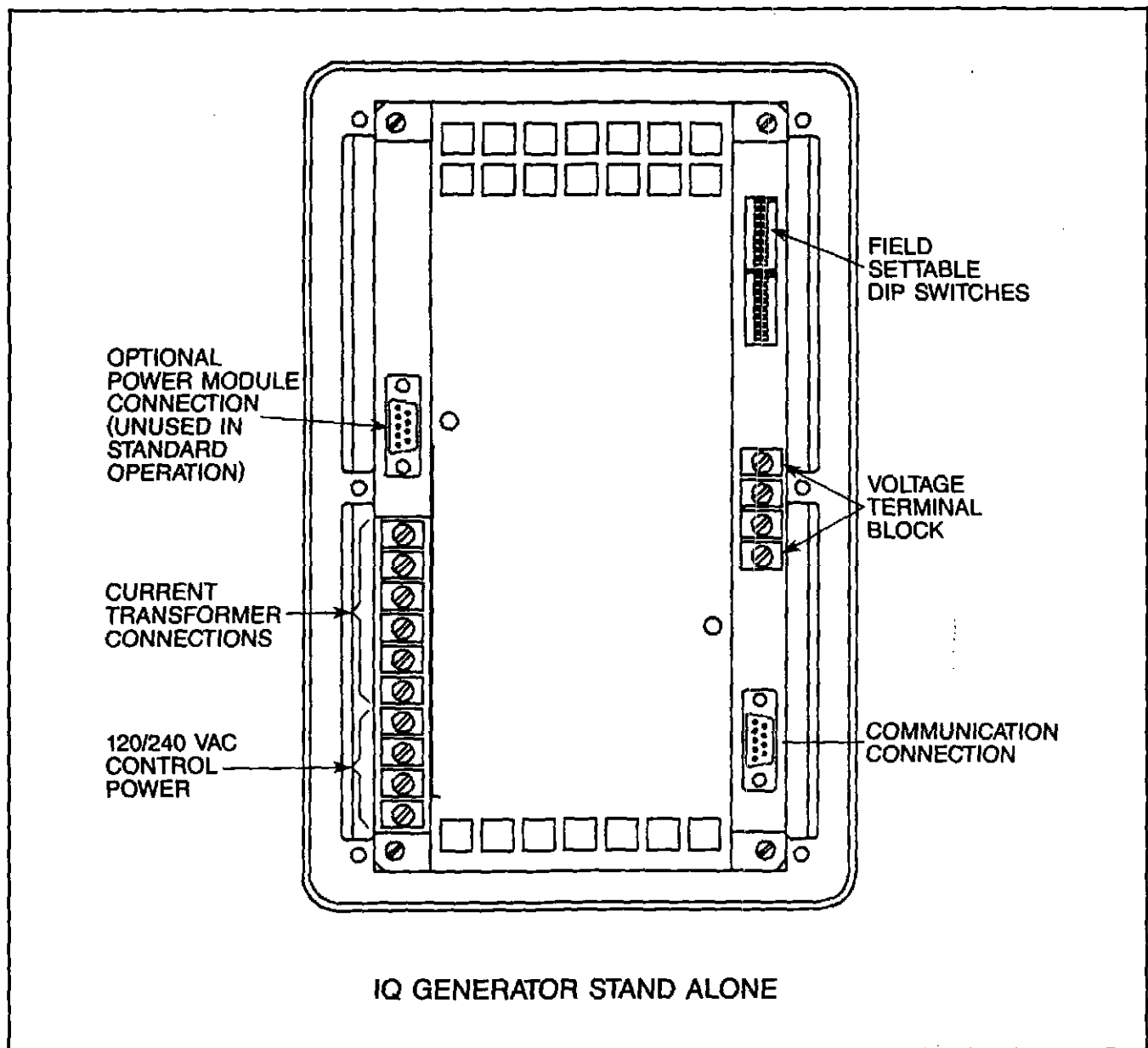

Figure 2.1A — Rear Access Area

2.1.1 Operator Panel — The Operator Panel, which is normally accessible from the outside of the panel or door, provides a means to:

- Monitor the actual metered values on the Display Window. (See Figure 3.1.)
- Determine which metered value is being displayed by means of an illuminated LED located at the left of the monitor menu
- Step through the menu of metered items and actual values

The use of the Operator Panel is detailed in Section 3.

2.1.2 Rear Access Area — The rear of the IQ Generator is normally accessible from the rear of the panel's door. All wiring connections to the unit are made at the chassis' rear.

When using the IQ Generator without the 3-phase Power Module, study Figure 2.1A and note the following items:

1. The 3-phase line voltage connects to the unit on the right side of the unit. These contacts can accept an input from 120 volts to 600 volts without external potential transformers. Phase A, B, C and Neutral.
2. Connections from the 3 required external current transformers are made at the Current Transformer Terminal Block located on the left side of the chassis.
3. The 9-pin connector on the upper left of the unit is unused in this case. 120 or 240 VAC must be supplied to terminals 7 and 10. For 120 VAC operation, jumpers must be installed from terminals 8 to 10 and 7 to 9. For 240 VAC operation, a jumper must be installed from terminal 8 to 9. This will supply control power to the IQ Generator independent of the AC line voltage being monitored.

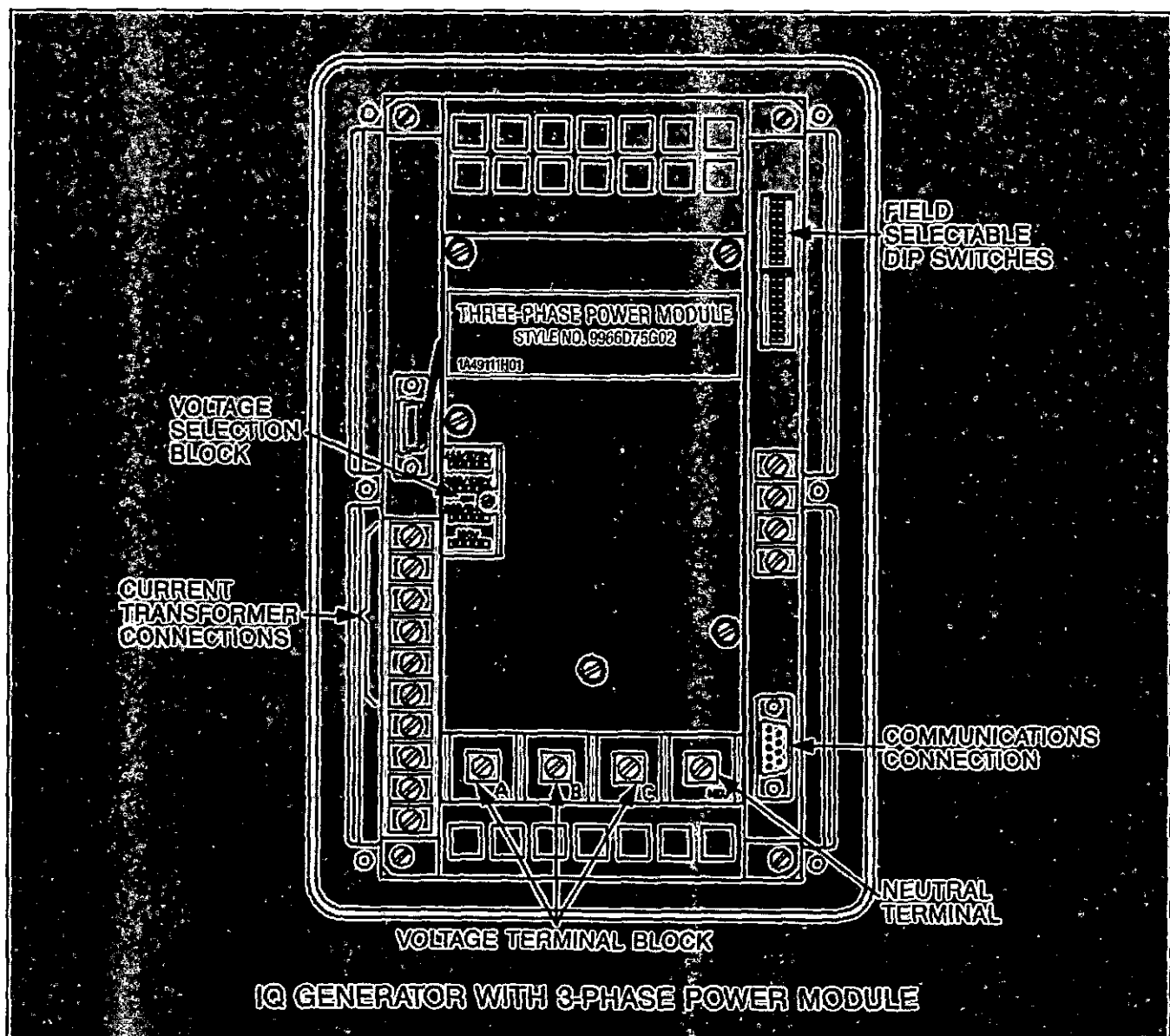

Figure 2.1B — IQ Generator with 3-Phase Power Module

 Shaded area designates information that replaces or supplements applications using the 3-phase Power Module.

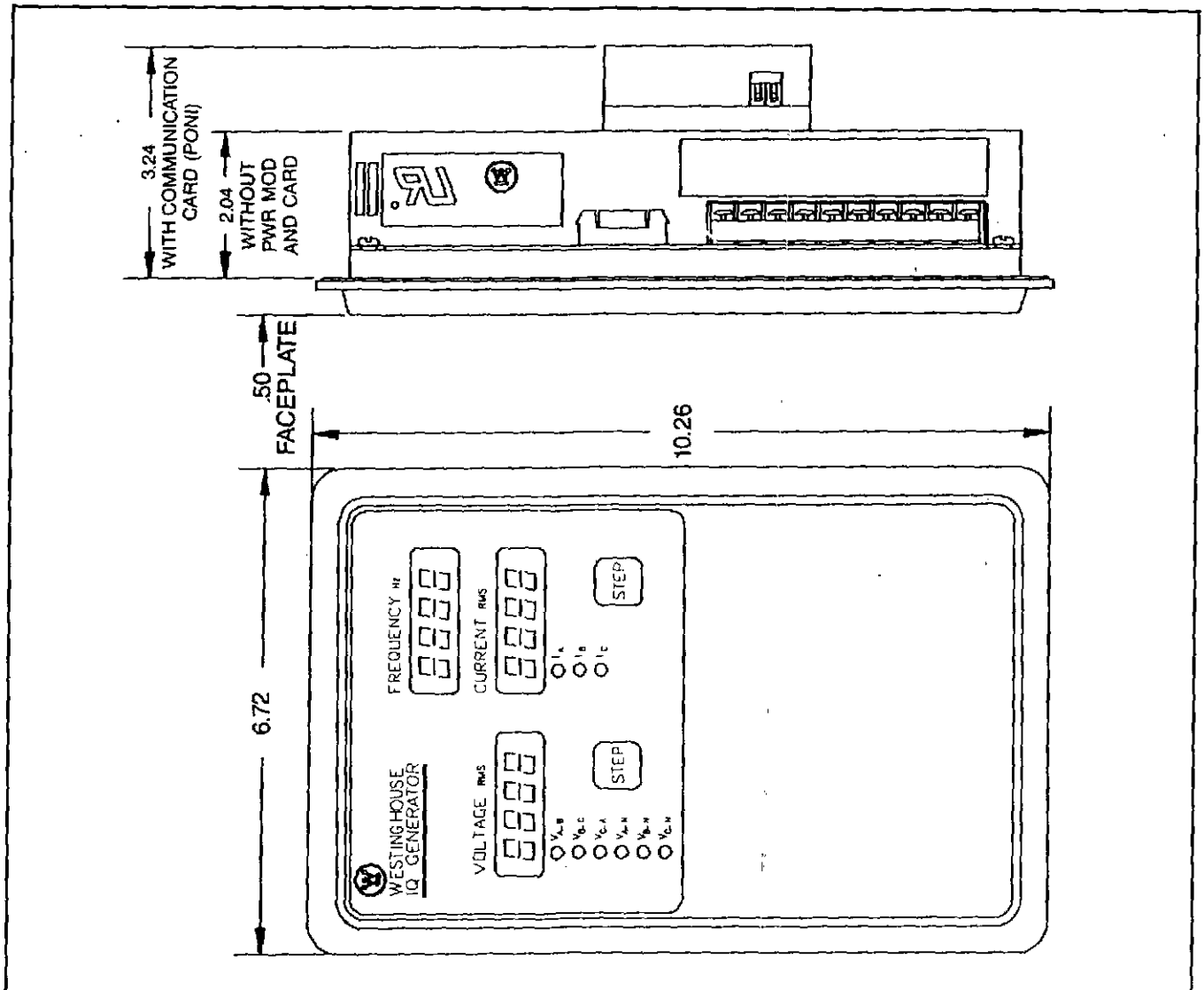
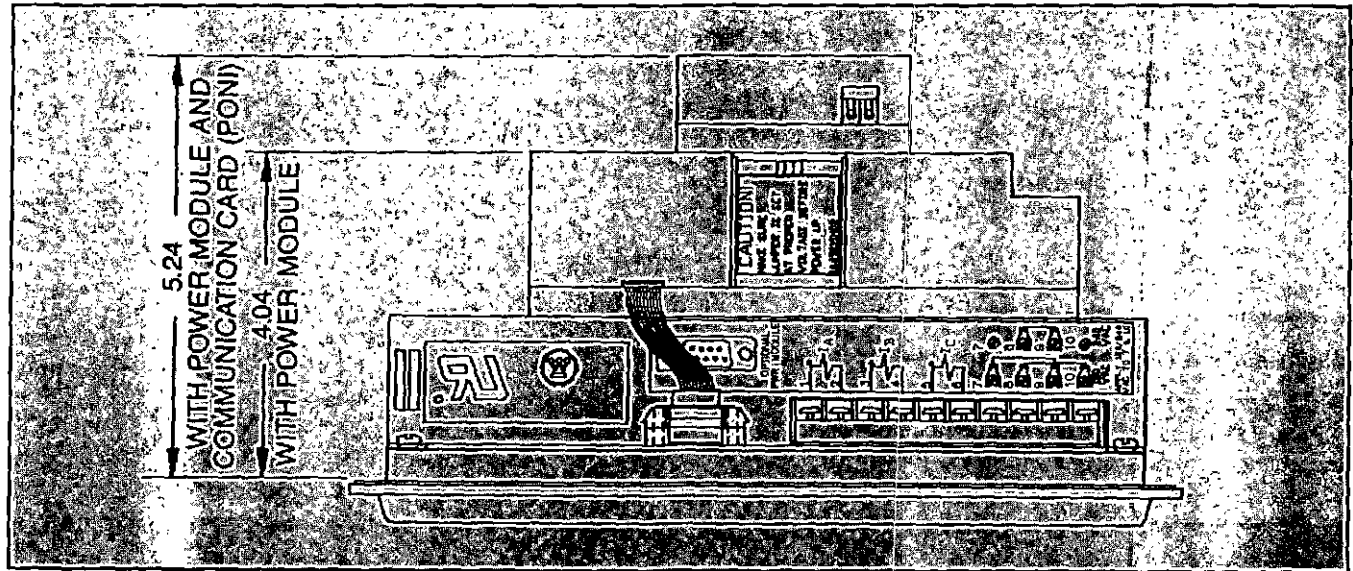

Figure 2.2 — Dimensions

independent of the AC line voltage being monitored.

4. A neutral is provided for 4-wire systems. (Where the monitored AC lines are a 3-wire configuration, this terminal is not to be wired.) Note: This neutral connection must be at the same potential as the ground connection used at the current transformers.
5. DIP switches, located on the right side of the chassis, tailor each IQ Generator to a specific application. These DIP switches are set according to characteristics such as the external PT and CT ratios. A complete description of each DIP switch setting is listed in Section 4.
6. A Communication Port, located on the lower right of the chassis, is designed to connect with an optional Communication Module (PONI Card).

When using the 3-phase Power Module, study Figure 2.1B and notice the differences between it and Figure 2.1A. The following are differences and additions to the 6 items above.

1. The 3-phase line voltage connects to the unit on the bottom of the 3-phase Power Module. These contacts can accept an input from 120 volts to 600 volts without external potential transformers. Phase A, B and C. The Neutral is connected on the bottom of the Power Module, next to the voltage connections.
3. The Power Module is connected to the 9-pin connector on the upper left of the unit. The Power Module supplies the IQ Generator with 3-phase voltage and control power. In this case, separate control power is not required. Thus, terminals 7 through 10 will be unused.
7. The Voltage Selector Jumper, essentially a shorting bar, must be positioned by the user during installation to match 1 of 4 operating voltage ranges. (Installation procedures, along with a listing of ranges, are given in Paragraph 4.1.4.)
8. The Voltage Power Module is factory-shipped mounted on the rear of the IQ Generator chassis. This component may be detached from the chassis and moved up to 36 inches (91.44 cm.) away if local codes prevent AC power devices being located on the cabinet door. An extension cable must be specified in this case.
9. A fuse is located in series with each of the 3 incoming AC lines. The fuses are 3/4 Amp, 600 volt, 200 kA interrupting rating. These fuses are internal to the Power Module and can be accessed by removing the three screws holding the cover in place. (See Figure 4.3) If it is necessary to replace fuses, make sure all voltage has been removed from the IQ Generator before removing/replacing the fuses.

2.1.3 External Hardware — Each IQ Generator requires current transformers be wired into the CT Terminal Block from an external location (see Figures 4.4A – 4.4F). These are user-supplied and must have a 5 ampere secondary.

Potential transformers are required when line voltage is above 600 volts. These are wired directly to the AC Line Connection Terminals (see Figures 4.4B, 4.4D and 4.4F).

2.2 Specifications — The following specifications of the IQ Generator are contained here:

- General specifications (Table 2.A)
- Metering specifications (Table 2.B)

Table 2.A

GENERAL SPECIFICATIONS

Device's Power Requirement	
PT Burden	0.02 VA
With 3-phase Power Module	10 VA
C.T. Burden	1.25 VA
Frequency	
	50/60 Hz ⁽¹⁾
Line Characteristics	
• Nominal Line \pm 20%	
• Will continue to operate in event of a phase loss	
Operating Temperature	
	0° to 70°C (32° to 158°F)
Storage Temperature	
	-20° to 85°C (-4° to 185°F)
Humidity	
	0 to 95% R.H. noncondensing
Fuses	
(Supplied with the unit) 3/4 ampere, 600 volts Buss Type KTK-R-3/4 (3 required)	

(1) DIP switch must be set for the correct incoming frequency.

Table 2.B METERING SPECIFICATIONS⁽¹⁾

Item	Description	Accuracy In % of Reading
AC Amperes	Phase A, B, C	\pm 1%
Voltage	Line A-to-B, B-to-C, and C-to-A	\pm 1%
Voltage	Line A-to-neutral, B-to-neutral, and C-to-neutral	\pm 1%
Frequency	Frequency in Hertz	\pm 0.5%

(1) Updated every 1.4 seconds with a 60 Hz line, or 1.5 seconds with a 50 Hz line, unless otherwise noted.
 (2) \pm 1% Accuracy of Reading valid for currents above 20% of the CT primary rating.

Section 3

OPERATOR PANEL

3.0 Introduction — This Section describes the operation of the IQ Generator. It is divided into the following 3 Sections:

- Pushbuttons (Par. 3.1)
- LEDs (Par. 3.2)
- Display Windows (Par. 3.3)

3.1 Membrane Pushbuttons — The Operator Panel supports 2 membrane pushbuttons. (See Figure 3.1.) Both membrane pushbuttons perform the following function:

- **STEP Display.** Pushbuttons are used to step through the monitored items listed on the respective monitor menus shown on the Operator Panel's face. Each time one of these pushbuttons is pressed, the LED at the left of the newly selected monitored item is illuminated. At the same time the current operating value corresponding to that

item is shown in the Display Window.

For example, while the V_{AB} LED is illuminated, the STEP pushbutton is pressed once. Immediately the LED next to V_{BC} lights, and a new value is shown in the Display Window.

Table 3.A contains a description of each of the 10 items that can be displayed.

3.2 LEDs — The Operator Panel LEDs are divided into 2 types:

3.2.1 Menu LEDs. At any given time, two of the LEDs associated with a menu item are illuminated. (See Table 3.A for a listing of these 10 items.) Each acts to identify which menu item value is currently being shown in the Display Window.

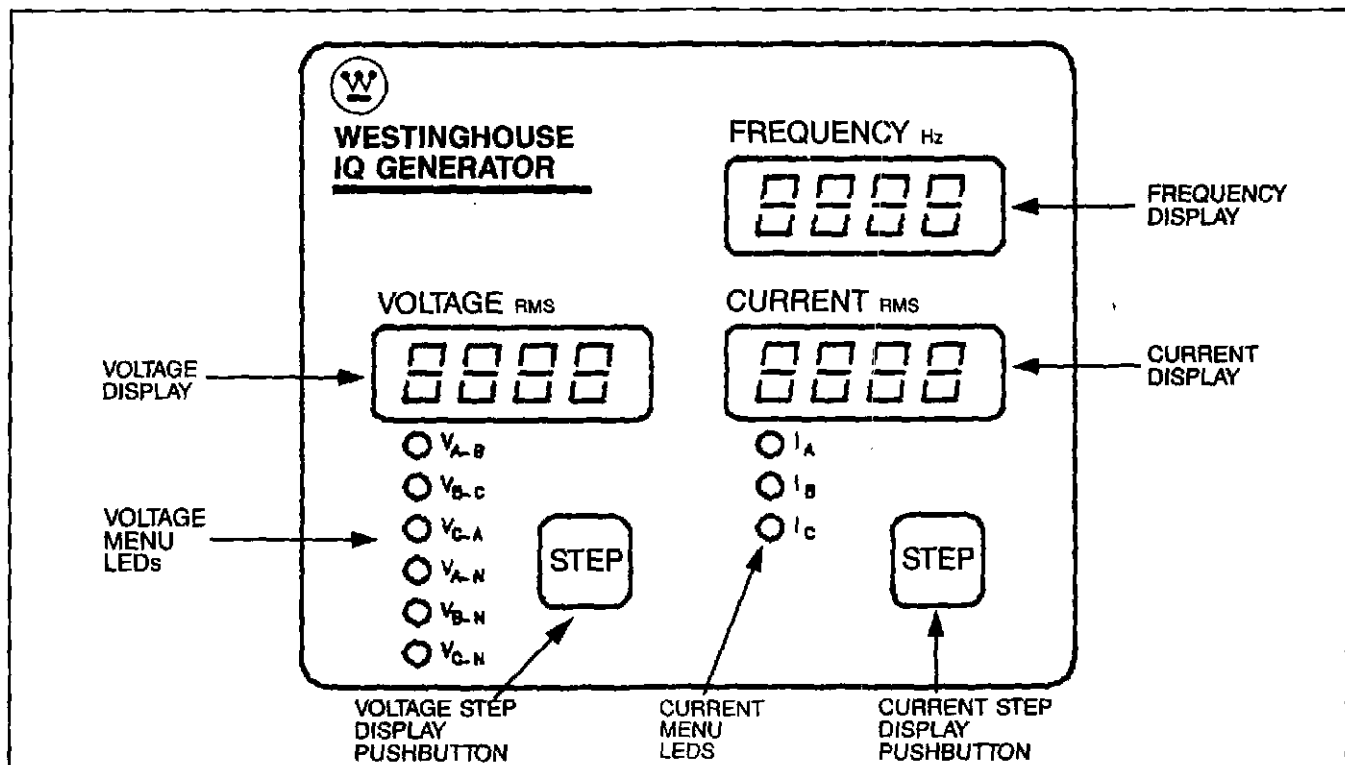

Figure 3.1 Operator Panel

Table 3.A
METERED VALUES

Selection		Display Format	Description
V _{A-B} Volts RMS	V KV	XXXX or XX.XX	Phases A-to-B
V _{B-C} Volts RMS	V KV	XXXX or XX.XX	Phases B-to-C
V _{C-A} Volts RMS	V KV	XXXX or XX.XX	Phases C-to-A
V _{A-N} Volts RMS (1)	V KV	XXXX or XX.XX	Phase A-to-neutral
V _{B-N} Volts RMS (1)	V KV	XXXX or XX.XX	Phase B-to-neutral
V _{C-N} Volts RMS (1)	V KV	XXXX or XX.XX	Phase C-to-neutral
I _A Amps RMS I _B Amps RMS I _C Amps RMS	Amps K Amps	XXXX or XX.XX	Phase currents
Frequency	Hertz	XX.XX	Frequency

(1) These values are skipped automatically with systems which do not wire the neutral line to the Neutral Terminal of the IQ Generator. The blanking occurs when position 8 of SW1 is set for the 3-wire position.

3.3 Display Windows — The three 4-digit LED Display Windows display three of the 10 metered values listed in Table

3.A at any given time. (See Paragraph 3.1 for details on selecting an individual value.)

Section 4

INSTALLATION AND STARTUP

4.0 Introduction — This Section describes the following items associated with the installation and startup of the IQ Generator:

- Mounting (Par. 4.1)
- Wiring (Par. 4.2)
- DIP switch setting (Par 4.3)
- Initial startup (Par. 4.4)

Earlier Sections, especially Section 2, Hardware Description, should be read by anyone using this Section to install an IQ Generator.

4.1 Panel Preparation — This Paragraph describes the panel preparation and mounting of the IQ Generator.

4.1.1 Cutout, Clearances — Since the IQ Generator is typi-

cally mounted on a cabinet's door, it is necessary to prepare a cutout in which it will be placed. The dimensions for this cutout, along with the location of 6 mounting holes, are shown in Figure 4.1. Before actually cutting the panel, be sure that the required 3-dimensional clearances for the IQ Generator chassis allow mounting in the desired location. (Clearances are shown in Figure 2.2.)

It is necessary to hold fairly close to tolerances when making the cutout and placing the holes for the mounting screws. In particular the horizontal dimension between the center of the mounting holes and the cutout's vertical edge must be within 0 and +0.050 in. (0.13 cm).

4.1.2 Mounting — Do not use a tap on the face since this will remove excessive plastic from the holes, resulting in less threaded material to secure the IQ Generator to its mounting panel.

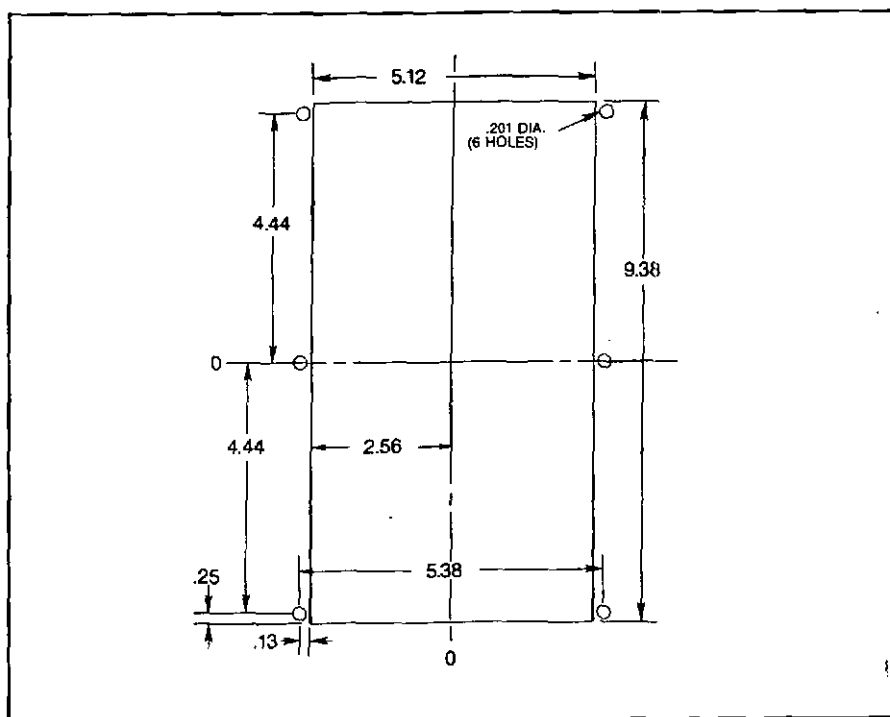

Figure 4.1 Chassis Cutout Dimensions

These dimensions must be -0 and $+0.050$ in.

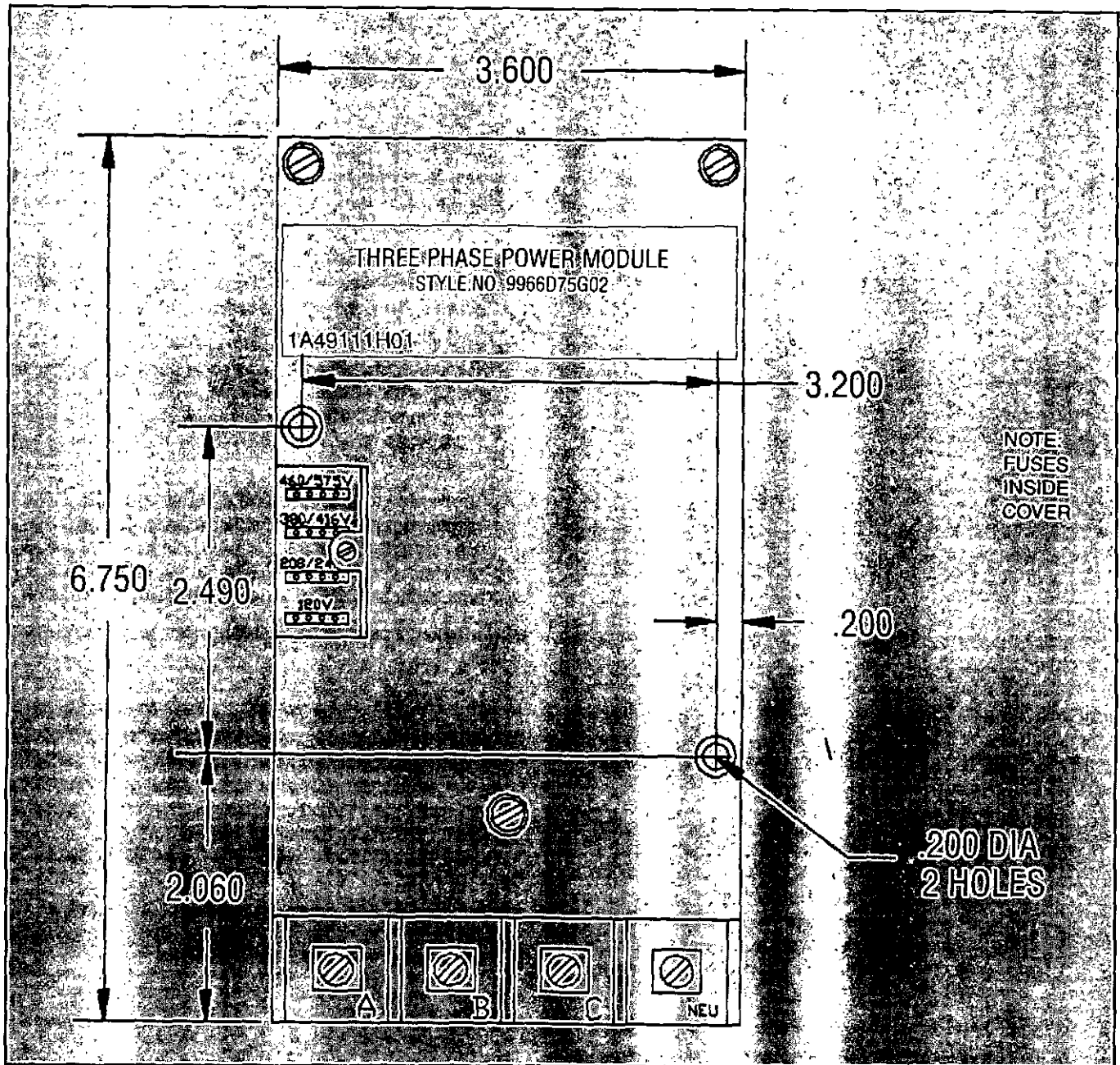

Figure 4.2 — Optional Power Module

Place the IQ Generator through the cutout in the panel. Be sure the Operator Panel faces outward. Use 0.5 in. (1.2 cm) long screws (included with the IQ Generator) to mount the unit on a single-thickness panel. Be sure to start the screws from inside the panel so that they go through the metal first.

4.1.3. Optional Power Module — In those cases where it is necessary to remove the Power Module and mount it separately from the chassis, be sure that:

- The location allows for a cable connection between the IQ Generator chassis and Power Module by means of the 36 in. (91.4 cm) Extension Cable Option.
- The separated Power Module can physically fit in the

location desired. (See clearance dimensions in Figure 4.2.)

Use the Module as a drilling template at the desired location. The two 8-32 screws can be used to remount the Module in holes properly drilled and tapped.

4.1.4. Voltage Selector Jumper — It is necessary to match the placement of the Voltage Selector Jumper with the incoming AC line voltage, measured line-to-line. (See Figure 2-1 B.)

Shaded area designates information that replaces or supplements applications using the 3-phase Power Module.

WARNING

Never attempt to change the position of the Voltage Selector Jumper when AC line power is applied to the IQ Generator. Personal injury, including death, could result.

CAUTION

The Voltage Selection Block on the Module accepts the Voltage Selector Jumper **ONLY**. Do not connect any other type of wires to this Terminal Block since improper operation and/or equipment damage will result. Do not apply control power to terminals 7 and 10 when the 3-phase Power Module is used.

A plastic cover with a screw is used to cover the Voltage Selector Jumper. The Jumper is positioned as determined by the monitored, nominal AC line voltage. There are 4 possible positions, which represent ranges, measured line-to-line. These are:

- 425 to 630 VAC = 460/575V
- 270 to 432 VAC = 380/416V
- 170 to 272 VAC = 208/220/240V
- 96 to 154 VAC = 120V

These ranges are indicated on the Power Module, as shown in Figure 4.2. Consult the wiring plan drawings made up by the user or OEM to determine the intended line voltage. Change the Selector Jumper to the Line Voltage when not using potential transformers. When using potential transformers with a 120 volt secondary, the Selector Jumper should be positioned for 96-154 volt range.

After repositioning the Jumper, replace plastic cover and secure with screw.

4.2 Wiring — The wiring of the IQ Generator must follow a suitable "wiring plan drawing." The term wiring plan, as used here, refers to the drawings made for the specific application. It describes all electrical connections between the IQ Generator and the machine or process equipment. This is made

up by the user or OEM.

A typical wiring plan is shown in Figures 4.4A thru 4.4F. Observe the Figures and note the following:

1. Phasing and polarity of the AC current inputs and the AC voltage inputs.
2. The incoming AC line phases A, B and C wire directly to the AC Line Connection Terminals on the chassis, when line voltage is 600 volts or less.
3. The wires connecting to the IQ Generator must not be larger than AWG No. 14. Larger wires will not connect properly with the various terminal blocks.
4. Wiring between the current transformers and the IQ Generator should be kept as short as possible (200 feet max.). Also, whenever possible, route these lines away from other AC lines and inductive devices. If the lines must cross other AC lines, plan to cross them at right angles.
5. Terminals ground, 2, 4, and 6 should be maintained at the same potential to prevent errors in the current metering. If the IQ Generator is to read line-to-neutral voltages, the Neutral must be connected to the system ground or terminals 2, 4, and 6 must be connected to Neutral.

All wiring must conform to applicable federal, state, and local codes.

WARNING

Ensure that the incoming AC power and all "foreign" power sources are turned OFF and locked out before performing any work on the IQ Generator or its associated equipment. Failure to observe this practice can result in serious or even fatal injury and/or equipment damage.

Shaded area designates information that replaces or supplements applications using the 3-phase Power Module.

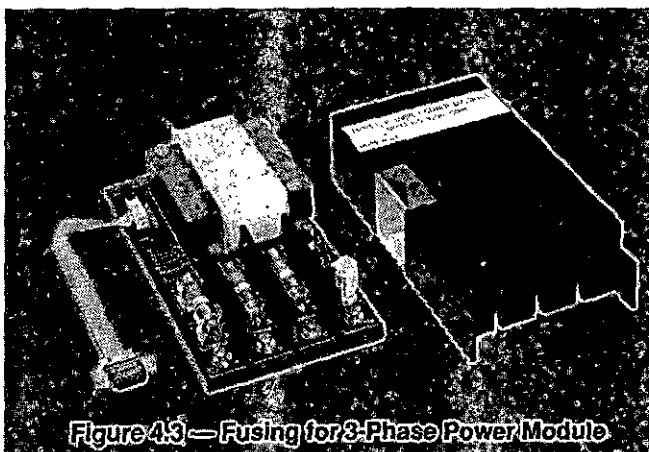

Figure 4.3 — Fusing for 3-Phase Power Module

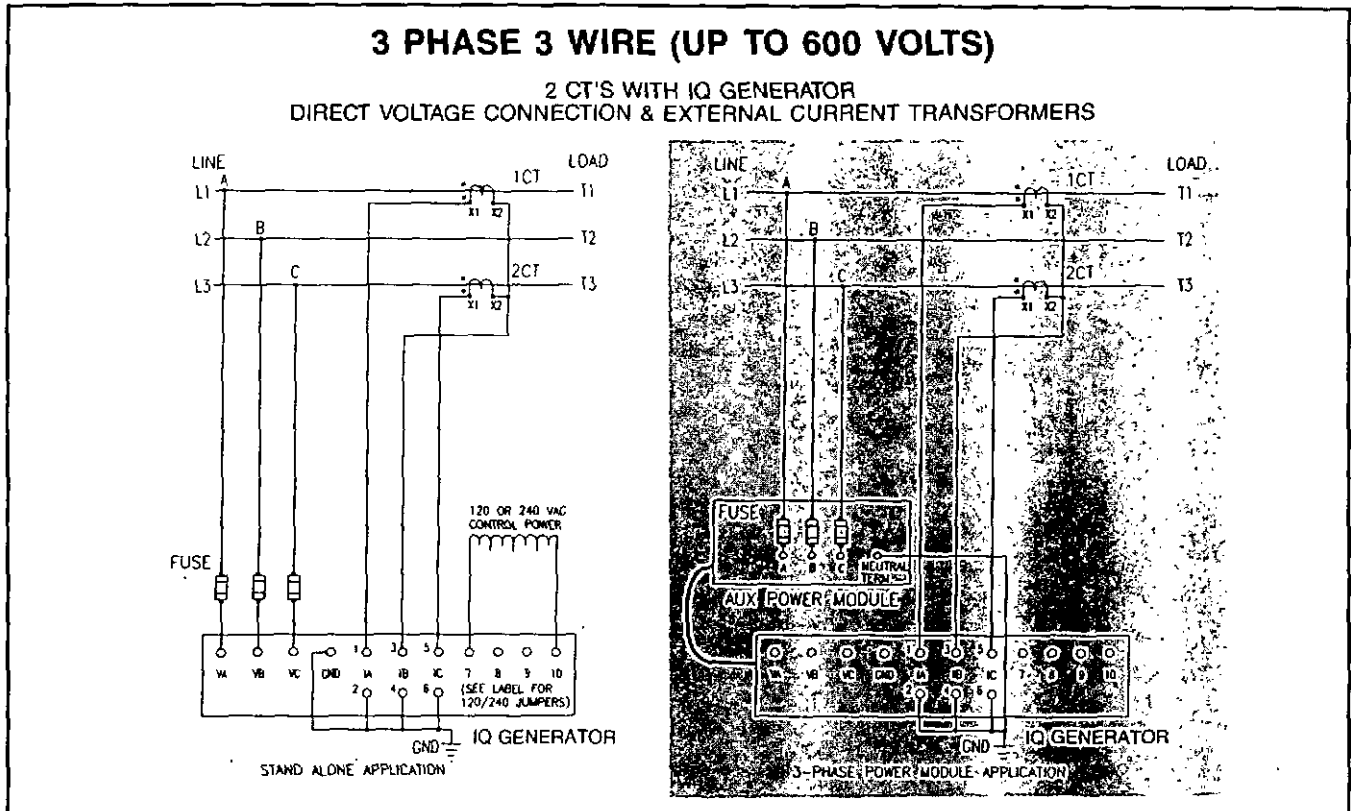

Figure 4.4A — Wiring Diagram

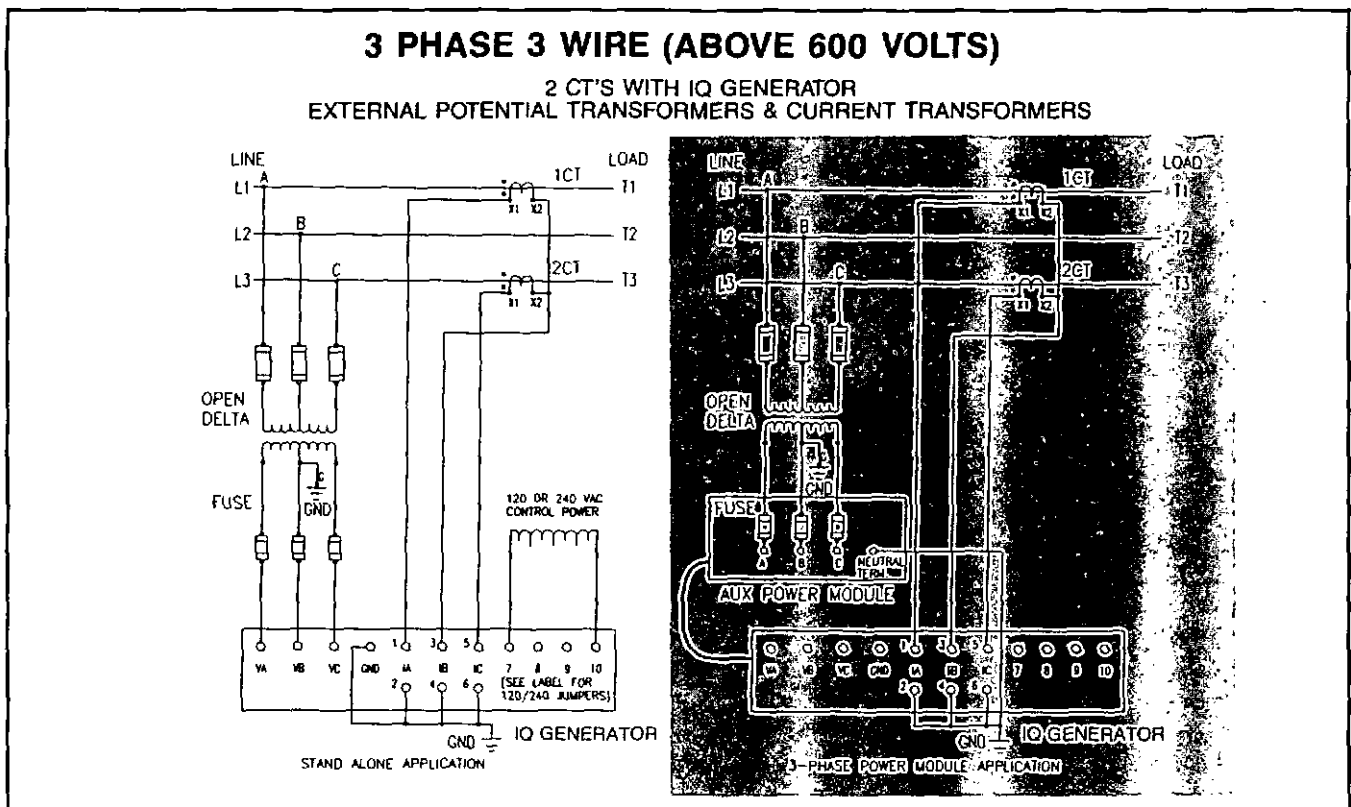

Figure 4.4B — Wiring Diagram

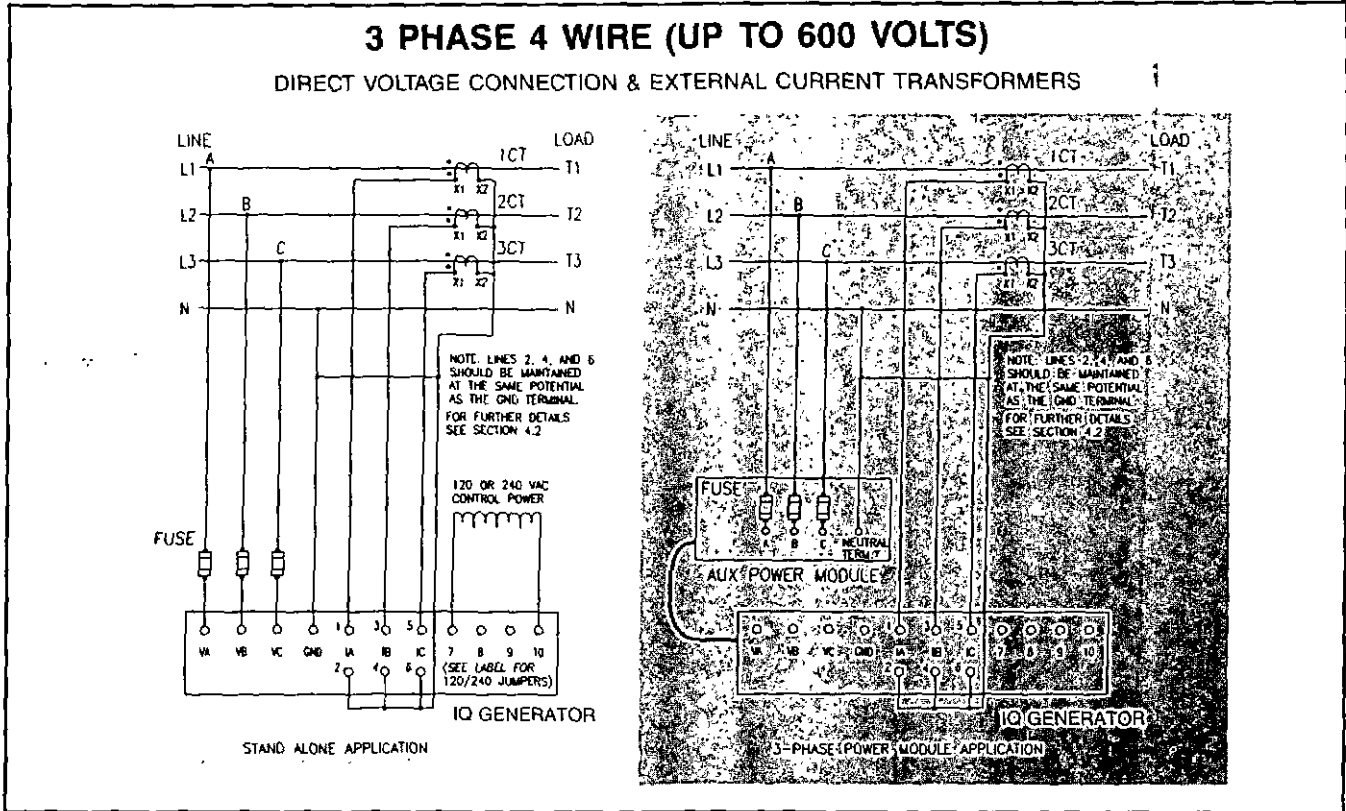

Figure 4.4C — Wiring Diagram

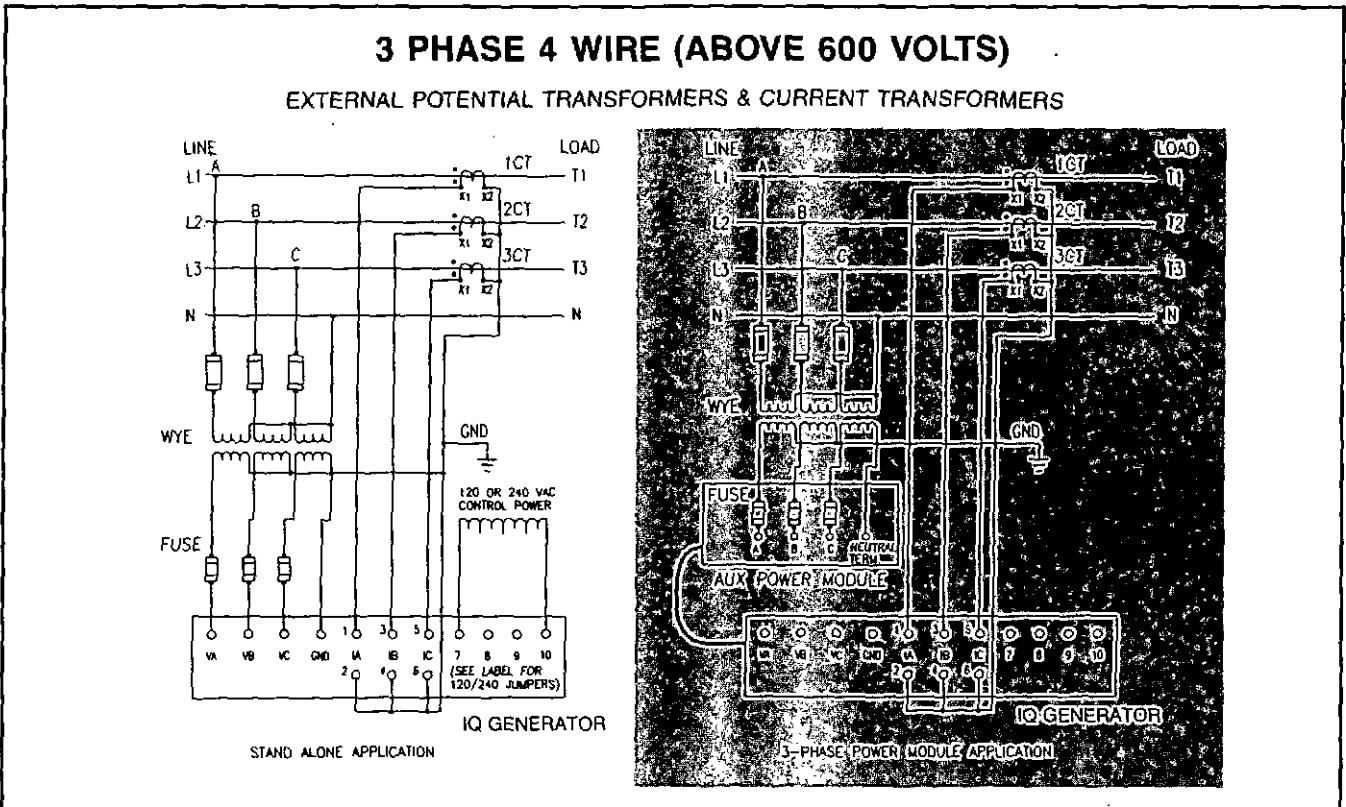

Figure 4.4D — Wiring Diagram

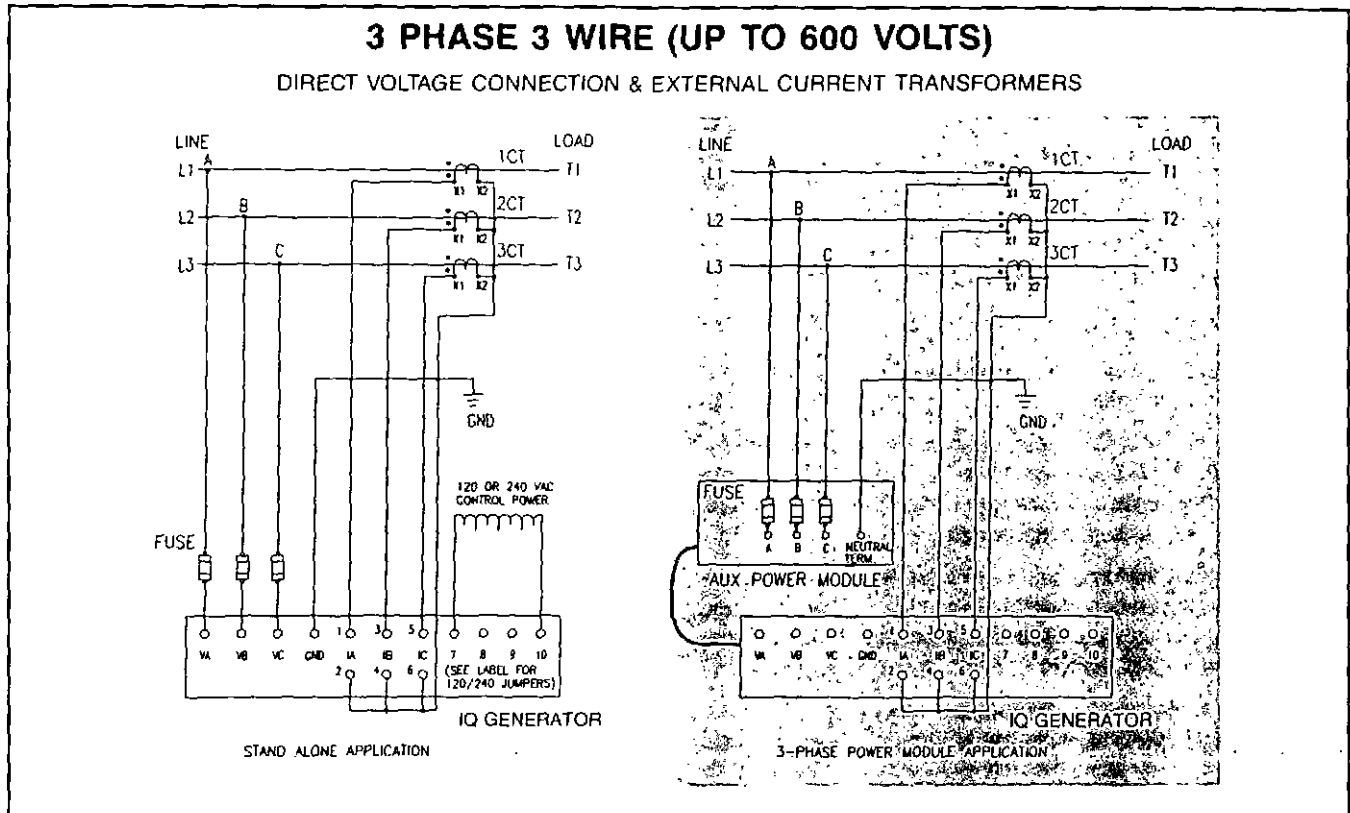

Figure 4.4E — Wiring Diagram

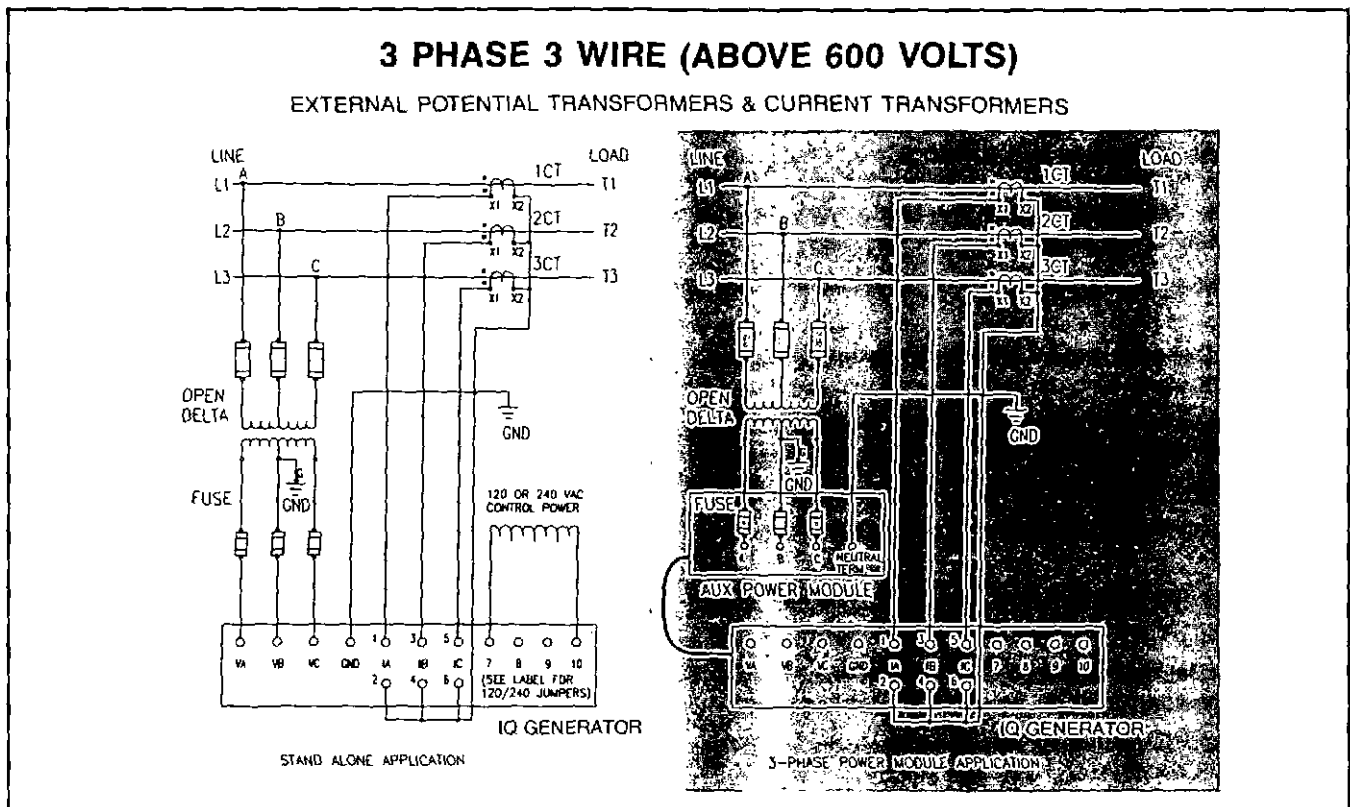

Figure 4.4F — Wiring Diagram

4.3 DIP Switch Settings — The DIP switches located and accessed from the rear-right portion of the chassis must be properly set according to application requirements. Obtain the Installation Record Sheet produced specifically for the application. A blank Record Sheet is shown in the Table 4.A, page 19. Both DIP switches contain eight 2-position switches which are set in combination. (See Figure 4.5.) The switches are turned ON or OFF by sliding the switch. As you face the DIP switches, slide:

- To the LEFT to turn the switch OFF
- To the RIGHT to turn the switch ON

Figure 4.6 shows a side view of a single slide switch and how it is turned on and off.

Observe the ON and OFF designations on the DIP switches shown in Figure 4.5. Always look for the OFF and ON designations on the hardware or printed circuit board to be sure you are setting the switches correctly.

After all the DIP switches are set according to the settings listed on the Installation Record Sheet, the system is ready to have AC power applied. Follow the procedure listed in Paragraph 4.4 when first applying power to the IQ Generator.

4.4 Initial Startup — The information here is intended to be used when first applying AC power to the IQ Generator. Each item is shown with a box to the left. In this way it can be used as a checklist to reduce the chance of omitting or skipping an item.

WARNING

The following startup procedures must be performed only by qualified personnel who are familiar with the IQ Generator and its associated electrical and/or mechanical equipment. Failure to observe this caution can result in serious or even fatal personal injury and/or equipment damage.

4.4.1 Before Power Application — Before applying AC power to the IQ Generator, perform the following:

- Verify that the incoming AC power to the system is disconnected.
- Verify all DIP switches are set according to the Installation Record Sheet.

If using the 3-phase Power Module, verify that the position of the Voltage Selector Jumper on the Voltage Terminal Block is correct for the nominal voltage.

- Verify that all wiring is correct, as shown on the wiring plan drawings.
- When possible, disable the IQ Generator until the rest of the machine or process has been started up and checked out.

4.4.2 Initial Power Application — Perform the following steps when first applying AC power to the IQ Generator:

If installing an IQ Generator without a three-phase Power Module (2D78533G02):

- Apply 120 or 240 VAC to terminals 7 and 10 of the unit. Zeros should appear in both screens and the V_{A-B} and I_A LEDs should be lit.
- Turn on AC power and verify the voltage and current values shown.

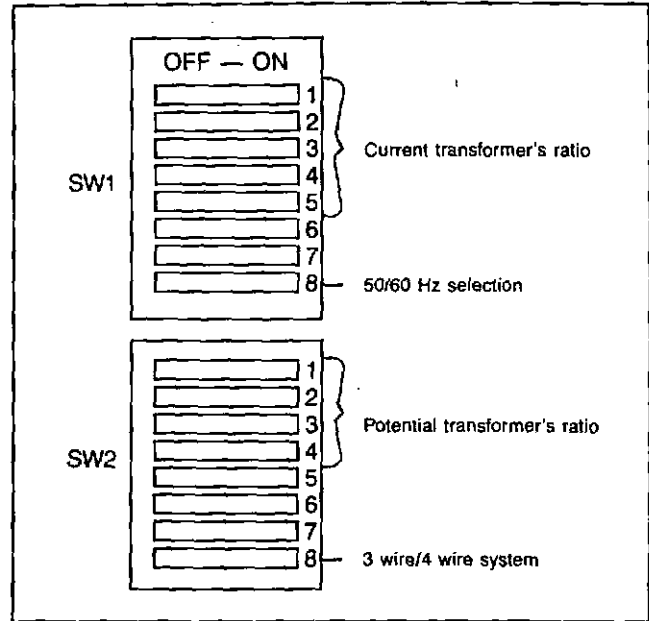

Figure 4.5 DIP Switches

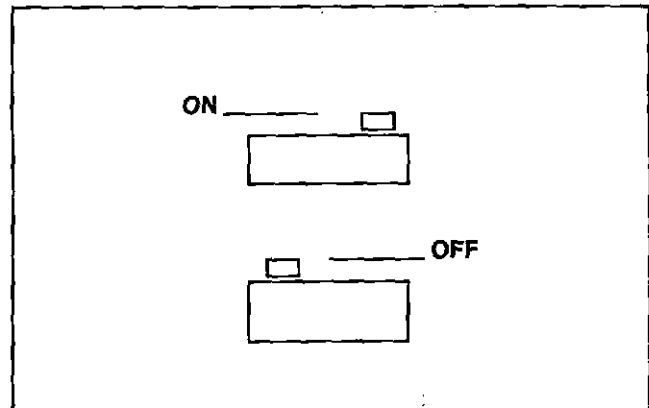

Figure 4.6 — DIP Switch (side view)

This is the last step if installing an IQ Generator without a three-phase Power Module.

If installing an IQ Generator with a three-phase Power Module (2D78533G04):

- Remove the 3 line fuses contained in the Power Module of the IQ Generator.
- Turn on AC power and verify that the line-to-line voltages (A-to-B, A-to-C, and B-to-C) fall within the correct range, as noted on the wiring plan drawing. Note: The voltage range must match the Voltage Selector Jumper's position. See Paragraph 4.1.4 which lists the ranges.
- If the voltages do not match—as determined by comparing the actual reading with the Voltage Selector Jumper's position, refer to the system wiring drawings to locate the error.
- Remove AC power and re-install the 3 line fuses.

Shaded area designates information that replaces or supplements applications using the 3-phase Power Module.

Restore AC power and verify that the Operator Panel functions, after an initial 2-second delay, are as follows:

- The I_A AMPS RMS LED illuminates
- The V_{AB} — LED illuminates
- The Display Window shows the actual line phase A amperes, the actual line phase A voltage and the actual frequency value.

Table 4.A
IQ GENERATOR INSTALLATION RECORD SHEET

DIP Switch	Slide Switch	Setting ON/OFF Combinations	Description
SW1	1	—	The ratio of the external current transformers. Refer to Table 5.A, page 20
	2	—	
	3	—	
SW2	4	—	Potential transformers if used. Refer to Table 5.B, page 21
	5	—	
	6	—	
	7	—	
	8	—	
SW1	6		Unused
	7		Unused
	8	—	Line frequency ON = 60 Hz; OFF = 50 Hz
SW2	5		Unused
	6		Unused
	7		Unused
	8	—	AC line wiring OFF = 4-wire; ON = 3-wire

 Shaded area designates information that replaces or supplements applications using the 3-phase Power Module.

Section 5

APPLICATION CONSIDERATIONS

5.0 General — This Section contains various considerations to be kept in mind when applying the IQ Generator to a specific application. It is designed primarily for the systems or application engineer responsible for making up the wiring plan drawings.

It is strongly suggested that all earlier Sections — especially 2 and 3 — be read thoroughly before proceeding.

5.1 DIP Switch Settings — A number of DIP switches, located on the right rear side of the chassis, tailor each IQ Generator to a specific application. The switches provide 4 selection groupings which must be set by the user during installation. Once these settings are determined, they should be recorded on a copy of the Installation Record Sheet, shown in Table 4.A, page 19. The filled-in Record Sheet should then be made available to the installation team and to maintenance personnel. Paragraph 4.3 describes how to physically set the switches.

5.1.1 Current Transformer Ratio — The ratio of the user-provided external current transformers can vary from 25:5 to 5000:5. Switch SW1, Nos. 1 thru 5 must be set to correspond to the external current transformer's ratio, as listed in Table 5.A.

5.1.2 Line Frequency — The IQ Generator can accept a line frequency of either 50 or 60 Hz. Selection is made at SW1, No. 8. Place the switch in the:

- OFF position for a 50 Hz line
- ON position for a 60 Hz line

Table 5.A
CT RATIO SETTINGS

CT Ratios	SW1 Switch Settings ⁽¹⁾				
	1	2	3	4	5
25:5	ON	ON	ON	ON	ON
50:5	OFF	ON	ON	ON	ON
100:5	ON	OFF	ON	ON	ON
150:5	OFF	OFF	ON	ON	ON
200:5	ON	ON	OFF	ON	ON
250:5	OFF	ON	OFF	ON	ON
300:5	ON	OFF	OFF	ON	ON
400:5	OFF	OFF	OFF	ON	ON
500:5	ON	ON	ON	OFF	ON
600:5	OFF	ON	ON	OFF	ON
800:5	ON	OFF	ON	OFF	ON
1000:5	OFF	OFF	ON	OFF	ON
1200:5	ON	ON	OFF	OFF	ON
1500:5	OFF	ON	OFF	OFF	ON
1600:5	ON	OFF	OFF	OFF	ON
2000:5	OFF	OFF	OFF	OFF	ON
2500:5	ON	ON	ON	ON	OFF
3000:5	OFF	ON	ON	ON	OFF
3200:5	ON	OFF	ON	ON	OFF
4000:5	OFF	OFF	ON	ON	OFF
5000:5	ON	ON	OFF	ON	OFF

(1) All other combinations are invalid.

5.1.3 Potential Transformer's Ratio — Some systems may include optional, user-provided potential transformers. Their ratios must be taken into account by means of settings on Switch **SW2, Nos. 1, 2, 3 and 4**, as listed in Table 5.B.

CAUTION

When external potential transformers are used, calculate the secondary output level of the transformers by dividing the nominal voltage input to the PT's primary side by the turns ratio. The result must be 120 VAC, measured line-to-line.

Examples:

1. 4160 Volt System: Select a potential transformer with a 4160/120 ratio = 35/1. Therefore, set switch SW2 for 35:1 ratio.
2. 3300 Volt System: Select a potential transformer with a 3600/120 ratio = 30/1. Therefore, set switch SW2 for 30:1 ratio.

If the optional Power Module is used, be sure that the Voltage Selector Jumper is set to the 120 volt level.

If potential transformers are not used, select a ratio of 1:1.

5.1.4 3 Wire/4 Wire Line — The IQ Generator can be used to monitor either a 3-conductor or 4-conductor AC line. An example of a 4-wire system is a case in which a transformer's secondary is wired in a wye configuration with the G neutral terminal ground brought out as the fourth wire. In this case the G fourth wire connects with the Neutral Terminal on the IQ Generator's chassis. (See Figure 2.1A.)

Switch **SW2, No. 8** must be set to correspond to the chosen wiring configuration. Set this switch to the:

- OFF position for a 4-wire wiring configuration
- ON position for a 3-wire wiring configuration

When the ON position is selected for the 3-wire configuration, the Display Window does not display the 3 line-to-neutral AC line measurements of the Operator Panel's menu. The measurements not displayed are:

- V_{A-N} Volts RMS
- V_{B-N} Volts RMS
- V_{C-N} Volts RMS

5.1.5 AC Line Voltage — The IQ Generator can be set to measure AC line voltage in one of two ways:

- Line-to-line — 3 Phase 3 Wire
- Line-to-neutral — 3 Phase 4 Wire

**Table 5.B
PT RATIO SETTINGS**

PT Ratio	SW2 Switch Settings			
	1	2	3	4
1:1 ⁽¹⁾	ON	ON	ON	ON
2:1	OFF	ON	ON	ON
4:1	ON	OFF	ON	ON
5:1	OFF	OFF	ON	ON
20:1	ON	ON	OFF	ON
30:1	OFF	ON	OFF	ON
35:1	ON	OFF	OFF	ON
40:1	OFF	OFF	OFF	ON
55:1	ON	ON	ON	OFF
60:1	OFF	ON	ON	OFF
70:1	ON	OFF	ON	OFF
100:1	OFF	OFF	ON	OFF
120:1	ON	ON	OFF	OFF
120:1	ON	ON	OFF	OFF
Any other combinations				
⁽¹⁾ Required setting when no PT used.				

Note that the settings of these potential transformers' switches allow the IQ Generator to calculate and display the original, unreduced line voltage even though the level at the AC Line Connection Terminals is reduced with an external potential transformer.

Shaded area designates information that replaces or supplements applications using the 3-phase Power Module.

Section 6

THEORY OF OPERATION

6.0 General — This Section provides a general description of how the IQ Generator functions internally. Its purpose is to give the user only an overview theory of operation.

6.1 Basic Block — The IQ Generator is controlled by a self-contained microprocessor which is directed by an "executive program" resident in ROM (read-only memory). (See Figure 6.1.) The microprocessor directs the following 2 operations:

- Monitoring the AC line voltage and currents and storing their levels in a "data table" which is a solid state mem-

ory device. (The actual signals from the AC line are "conditioned" by various circuits grouped together here and referred to simply as the line interface.)

- Updating the Operator Panel on a regular basis. When a component of the Panel — such as the STEP Display pushbutton — is pressed, the executive program reacts by displaying the new information requested in the Display Window.

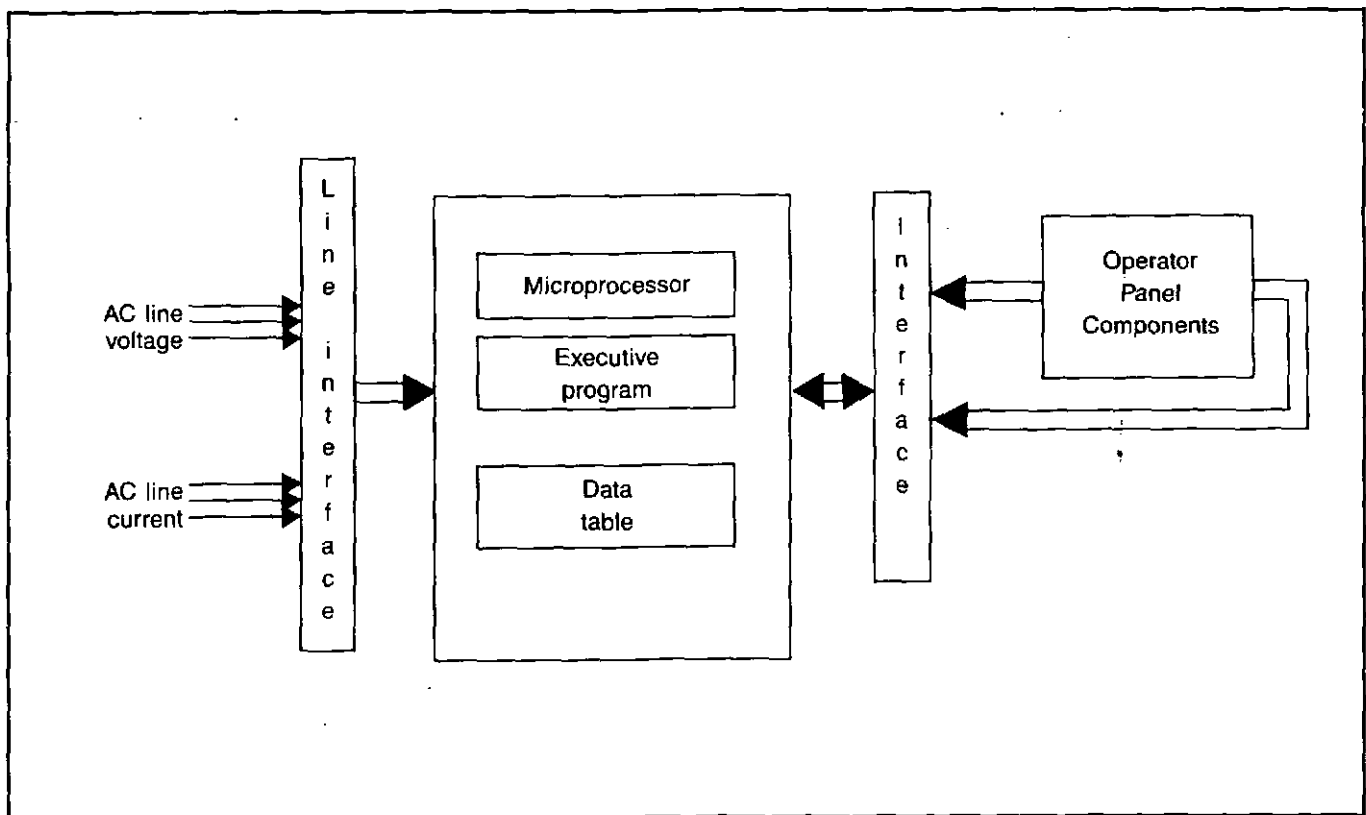

Figure 6.1 — IQ Generator Basic Block

Section 7

MAINTENANCE

7.0 General — This Section describes maintenance procedures for the IQ Generator. The information contained here is divided as follows:

- Isolating a malfunction (Par. 7.1)
- Replacing the IQ Generator (Par. 7.2)

Earlier Sections of this Manual, especially Section 2, Hardware Description; Section 3, Operator Panel; and Section 4, Installation and Startup, should be read thoroughly to familiarize the maintenance person with the IQ Generator.

Table 7.A

INITIAL POWER-ON TROUBLESHOOTING

Symptom	Probable Cause(s)	Solution
All Operator Panel indicators are off.	• Control power is deficient.	<ul style="list-style-type: none"> • Locate deficiency in control power line. • Replace unit. (See Paragraph 7.2)
	◦ AC line, Voltage Selector Jumper, or external PT's are not properly selected, wired, or installed.	<ul style="list-style-type: none"> ◦ Verify that the AC line and/or PT's are wired as shown on the wiring plan drawings for the application. ◦ Check the position of the Voltage Selector Jumper for proper placement. (See Paragraph 4.1.4.) ◦ Replace unit. (Paragraph 7.2)
One or more voltage phases read incorrectly.	◦ Blown or loose fuse(s)	<ul style="list-style-type: none"> ◦ Check fuse(s) in affected phase(s), located above voltage inputs behind cover of Power Module. Reseat fuse(s). Replace if necessary with 3/4 Ampere, 600 volt, Buss Type KTK-R-3/4. (See Par. 2.1.2, no. 9)

7.1 Troubleshooting — This Paragraph describes the following procedures:

- Troubleshooting when AC power is first applied to an IQ Generator in an application (Par. 7.1.1).
- Troubleshooting assuming the IQ Generator has been installed and was operational for a period of time (Par. 7.1.2).

7.1.1 Initial Startup — This Paragraph lists procedures to follow when the IQ Generator is not operating properly after AC power is first applied. The procedures assume that:

- All steps listed in Paragraphs 4.4.1 and 4.4.2 have been completed, and
- One or all display windows do not display values and/or the I_A AMPS RMS LED or V_{AB} VOLTS RMS LED are not lit.

 Shaded area designates information that replaces or supplements applications using the 3-phase Power Module.

DANGER

All maintenance procedures must be performed only by qualified personnel who are familiar with the IQ Generator and the associated AC lines being monitored. Failure to observe this caution can result in serious or even fatal personal injury and/or equipment damage.

The following procedures at times involve working in equipment areas where the hazard of fatal electrical shock is present. Live parts are exposed. Personnel must exercise extreme caution to avoid injury, including possible fatal injury.

Always disconnect and, if necessary, lock out the AC power source before touching the components on the rear of the IQ Generator. Failure to do so can result in serious or even fatal personal injury and/or equipment damage.

Table 7.B
OPERATIONAL TROUBLESHOOTING

Symptom	Probable Cause(s)	Solution
All Operator Panel indicators are off.	• Control power is deficient.	• Locate control power deficiency.
	• Unit is malfunctioning.	• Replace unit. (See Paragraph 7.2)
	• AC line fuses on the IQ Generator are blown or missing, or are not contacting correctly.	• Verify that the incoming AC line is at the correct voltage level. Check that the fuses are sitting correctly in their housing.
One or more voltage phases read incorrectly.	• Blown or loose fuse(s)	• Check fuse(s) in affected phase(s), located above voltage inputs behind cover of Power Module. Reseat fuse(s). Replace if necessary with 3/4 Ampere, 600 volt, Buss Type KTK-R-3/4. (See Par. 2.1.2, no. 9)

Before attempting to troubleshoot the IQ Generator and the associated equipment, read and observe the Dangers listed in the box on the previous page. When the normal operational conditions of the IQ Generator listed above cannot be observed, refer to Table 7.A. This Table lists a probable cause and suggests an approach for each possible symptom.

7.1.2 Operational Troubleshooting — A troubleshooting chart, shown in Table 7.B, lists the probable causes and solutions for each of a number of symptoms. This Table assumes the IQ Generator has been operating properly for a period of time. Before attempting to troubleshoot the unit and its associated equipment, read and observe the Dangers listed in this Section.

7.2 Unit Replacement — Follow this procedure to replace the IQ Generator.

Step 1 — Remove AC power at the main disconnect or isolation switch of the line being monitored. If the switch is located at a distance from the IQ Generator, lock it out to guard against personnel accidentally turning it on.

Step 2 — Before disconnecting any wires from the unit, make sure they are individually identified to assure that reconnection will be correctly performed. Make a sketch to help with the task of terminal and wire identification.

Step 3 — If an optional module connects with the Communications Port, carefully unplug it. The connectors may be screwed together.

Step 4 — If the unit has an optional Power Module, carefully unplug the cable from the IQ Generator's chassis, not the Power Module. (See Figure 2.1B.)

Step 5 — Loosen each screw terminal or nut where there is

a wire connection. Remove the associated wire.

Step 6 — Remove the 6 mounting screws holding the unit against the door or panel. These are accessed from the IQ Generator's rear.

CAUTION: Be prepared to support the IQ Generator from its front side once most of the screws are loosened or removed. Without such support, the unit could fall off, and the Panel could be damaged.

Step 7 — Carefully lay these screws aside for later use.

Step 8 — Read Paragraph 4.1.2 before attempting to mount the replacement unit.

Step 9 — Reverse the procedure noted in Steps 3 thru 6.

Step 10 — Using the sketch noted in Step 2, above, replace each wire at the correct terminal. Be sure each is firmly tightened.

Step 11 — Set the DIP switches on the right rear of the unit according to the individual application's Installation Record Sheet. (If necessary, see Paragraph 4.3 for details.)

Step 12 — Restore AC power and verify that the Operator Panel functions, after an initial 2-second delay, are as follows:

- The I_A AMPS RMS LED and V_{AB} VOLTS RMS LED illuminate.
- The Display Window shows the actual line phase A amperes, phase A-B voltage and frequency.

 Shaded area designates information that replaces or supplements applications using the 3-phase Power Module.

IQ GENERATOR USER MANUAL

Customer Comments

Did you find any corrections that need to be made to this manual? (Include page number.)

Were any parts of the manual unclear? Do any require further detail or description? (List parts.)

What are your special application needs?

As part of a constant effort to serve your needs, Westinghouse is interested in any information you can supply about your application or use of the IQ GENERATOR. If you would like to share this information, please check the box below.

Please call me to discuss my application or use of the IQ GENERATOR.

Name _____ Title _____

Company _____ Phone _____

Street and Number _____

City _____ State _____ Zip _____

Just fill in above and drop this card in the mail. No postage needed.

Information Request

Please send me updated application materials when available.

Please send me information on _____

Please have a Sales Engineer call.

Please contact me to discuss INCOM Local Area Network applications.

Name _____ Title _____

Company _____ Phone _____

Street and Number _____

City _____ State _____ Zip _____



Distribution and Control Business Unit
Electrical Components Division

Tear along perforation. Fold the top half down and tape.

ATTN: COMMUNICATIONS PRODUCTS
MARKETING

5 Parkway Center
Pittsburgh, PA 15220

**Westinghouse
Electric Corporation**

POSTAGE WILL BE PAID BY ADDRESSEE

BUSINESS REPLY MAIL
First Class Permit No. 46 Asheville, NC



NO POSTAGE
NECESSARY
IF MAILED
IN THE
UNITED STATES



**PLACE
STAMP
HERE**

**Westinghouse
Electric Corporation**
5 Parkway Center
Pittsburgh, PA 15220