

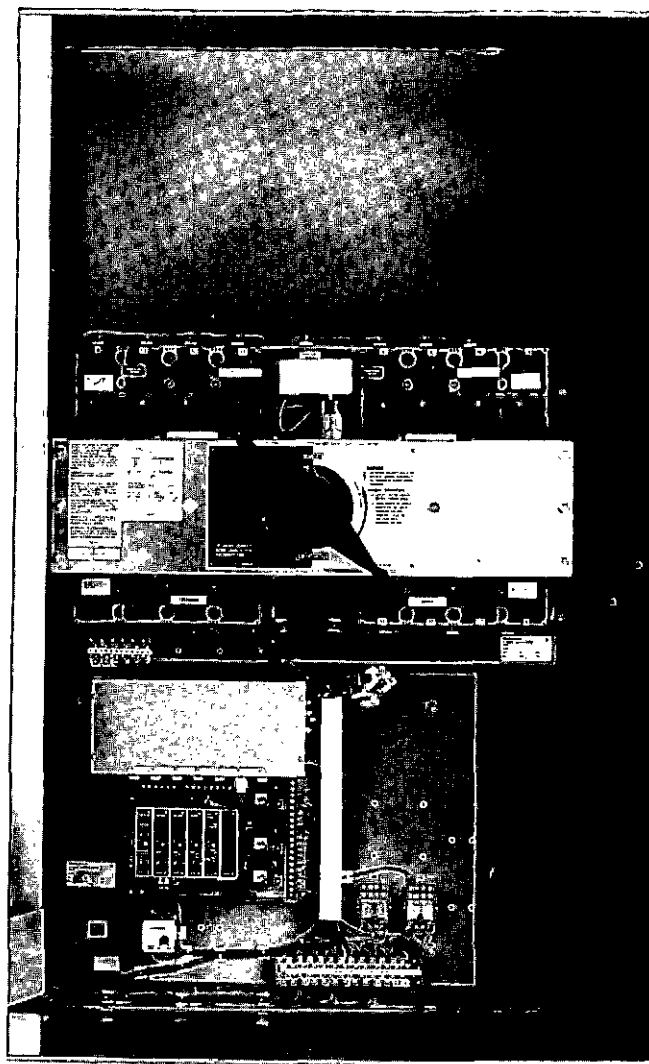

September, 1991
Supersedes Technical Data 29-295,
pages 1-44, dated September, 1990
Mailed to: E, D, C/29-900A

Automatic, Basic and Manual Types

Transfer Switch Equipment 30 through 4000A

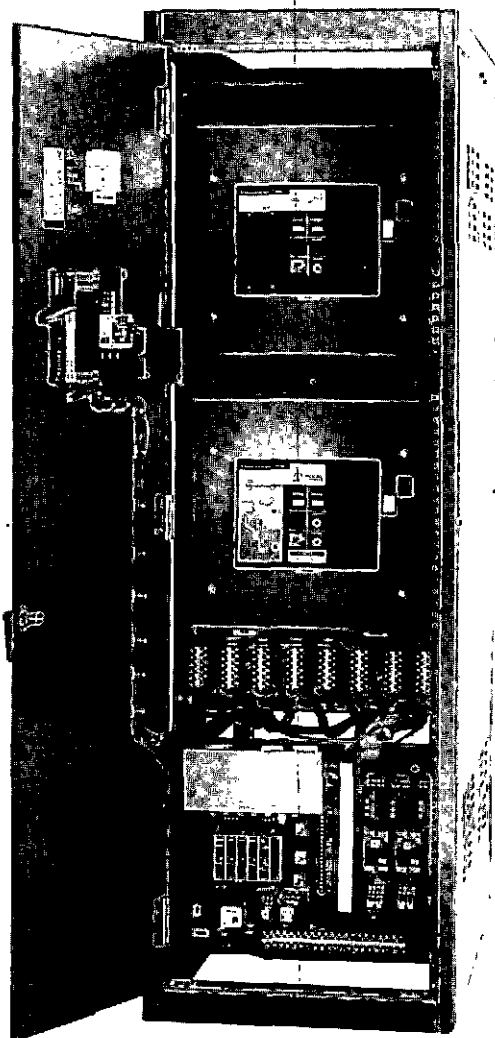

- Westinghouse Transfer Switches
 - Solid State Logic
 - Relay Logic
- Drawout Transfer Switches

- Automatic Transfer Switches
- Non-Automatic Transfer Switches
- Manual Transfer Switches
- Service Entrance Transfer Switches
- Bypass Isolation Transfer Switches



Transfer Switch Equipment 30 through 4000A

Table of Contents

General Information	A
Transfer Switch Logic	B
Automatic Transfer Switches	C
Modular Solid State Logic Relay Logic	
Non-Automatic Transfer Switches	D
Manually Operated Electrically Operated	
Service Entrance Transfer Switches	E
Bypass Isolation Transfer Switches	F
Options/Accessories	G
Catalog Information	H
Ordering Information	
Terminal Data	
Open Unit Dimensions	
Specification Section	I

Westinghouse Transfer Switches

Control and Protection for Emergency Power Systems

Westinghouse is a world leader in the design and manufacture of power switching and power systems protection devices. The Westinghouse family of products includes a complete line of Transfer Switch Equipment designed to control Emergency and Standby power systems.

Automatic Transfer Switches: Available open or enclosed with either solid state or relay logic. Amp Rating: 30 - 4000A

Bypass Isolation Transfer Switches: Designed to allow for on-site testing, maintenance and inspection while maintaining continuity of power to critical loads.
Amp Rating: 100 - 1000A

Non-Automatic Transfer Switches: These manually initiated, electrically operated switches are used in applications where an automatic load transfer is not necessary.
Amp Rating: 100 - 4000A

Manual Transfer Switches: Engineered for those applications requiring manual transfer of power. Available in either a Dual Handle or Single Handle design.
Amp Rating: 100 - 1000A

Service Entrance Transfer Switch: A Westinghouse exclusive — these switches meet all the NEC and UL 1008 standards for safety requirements pertaining to service equipment.
Amp Rating: 100 - 4000A

Index

Westinghouse Transfer Switches **meet and exceed all of the industry standards for endurance, reliability and performance.**

They are listed under Underwriters Laboratory's UL 1008 Standard for Safety for Automatic Transfer Switches. The Power Switching Section also complies with UL 489 Underwriters Laboratory's Standard for Circuit Breakers and UL 1087 Underwriters Laboratory's for Molded Case Switches.

Westinghouse **File #E38116** covers the requirements for Westinghouse Transfer Switches intended for use in applications to provide lighting and power as follows:

Emergency Systems: Westinghouse Transfer Switches are designed and built in accordance with:

- Articles 517 and 700 in the National Electric Code
- ANSI/NFPA 70
- National Fire Protection Association No. 76A
- UL 1008
- EGSA Standard for Transfer Switches
- NEMA Part ICS 2-447 for AC Transfer Switch Equipment

Standby Systems: Westinghouse Transfer Switches also meet or exceed the requirements of Article 702 of the NEC and for . . .

Legally Required Standby Systems: defined in National Electric Code Article 701

In addition, Westinghouse Transfer Switch equipment can be supplied with accessories to meet the requirements of:

- NFPA 110 for Emergency and Standby Power Systems
- NFPA 99 for Health Care Facilities

NEMA Definition

The National Electrical Manufacturers Association publishes a Standard (ICS 2-447) covering Transfer Switches.

By definition, an Automatic Transfer Switch is self-acting equipment for transferring one or more load conductor connections from one power source to another.

A Non-Automatic Transfer Switch is a device operated by direct manpower or via electrical remote manual control for transferring one or more load conductor connections from one power source to another.

A Bypass Isolation Switch is a manually operated device used in conjunction with a Transfer Switch to provide means of directly connecting load conductors to a power source and of disconnecting the Transfer Switch to permit maintenance and testing of the transfer switch with minimal interruption to the load.

Transfer Switch Classifications

NEMA ICS 2-447.10 covers the classification of Transfer Switches. In this Standard, it classifies Transfer Switches as either Type A or Type B. **Type A (PC), is a Transfer Switch that is not intended to provide integral overcurrent (short circuit and overload) protection. This is the Standard Westinghouse Transfer Switch design utilizing high withstand molded case switches as main power contacts.**

Type B (CB), is a Transfer Switch that is intended to provide integral overcurrent (short circuit and overload) protection. Westinghouse can supply a Type B Transfer Switch as an option or if the requirement is for a Service Entrance Transfer Switch, it comes standard as a Type B Transfer Switch.



Transfer Switch Equipment 30 through 4000A

A

Reliability and Quality:

Westinghouse Transfer Switches offer the assurance of reliable performance. The Westinghouse switch is the only switch on the market which, by design, is tested to multiple UL standards (UL1008,UL1087,UL489).

Westinghouse, as an inaugural winner of the prestigious Malcolm Baldrige Quality Award, does more than commit to quality. We succeed in providing the highest quality products and services available.

The Malcolm Baldrige National Quality Award is an annual Award to recognize U.S. companies which excel in quality achievement and quality management.

Companies participating in the Award process submit applications which include completion of the Award Examination. The Examination is based upon quality excellence criteria, created through a business-government partnership. In responding to these criteria, applicants are expected to provide information and data on their quality processes and quality improvement. Information and data submitted must be adequate to demonstrate that the applicant's approaches could be replicated or adapted by other businesses.



The Award promotes:

- awareness of quality as an increasingly important element in competitiveness,
- understanding of the requirements for quality excellence, and
- sharing of information

The Award Examination is designed to serve not only as a reliable basis for making Awards, but also to permit a diagnosis of the applicant's overall quality management. All Award applicants receive feedback reports prepared by teams of U.S. quality experts.

The importance of just competing for the U.S. Government's Baldrige Award is so significant that Westinghouse has developed an internal award, the George Westinghouse Total Quality Award, which serves for us as a prelude to competing for the national award. In fact, a sister Westinghouse business won the inaugural Baldrige Award in 1988. This success

has challenged other Westinghouse businesses, including Transfer Switches, to become the best in providing superior quality products. At Westinghouse, we're proud to say, "**You can be sure.....if it's Westinghouse**".



Transfer Switch Equipment 30 through 4000A

TYPICAL TRANSFER SWITCH APPLICATIONS

A

Utility Service - Standby Generator

The most common application of Transfer Switch Equipment involves switching of critical loads from a preferred utility service to an onsite, engine driven generator power source.

Fig. 1

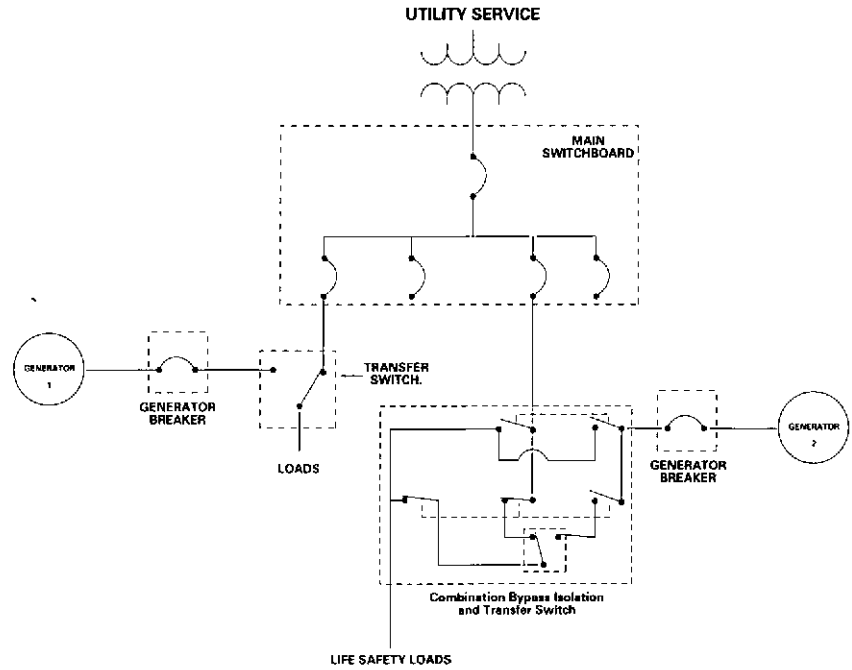

Dual Utility Service

Transfer Switch equipment is often employed to switch load circuits between separate utility services.

Fig. 2

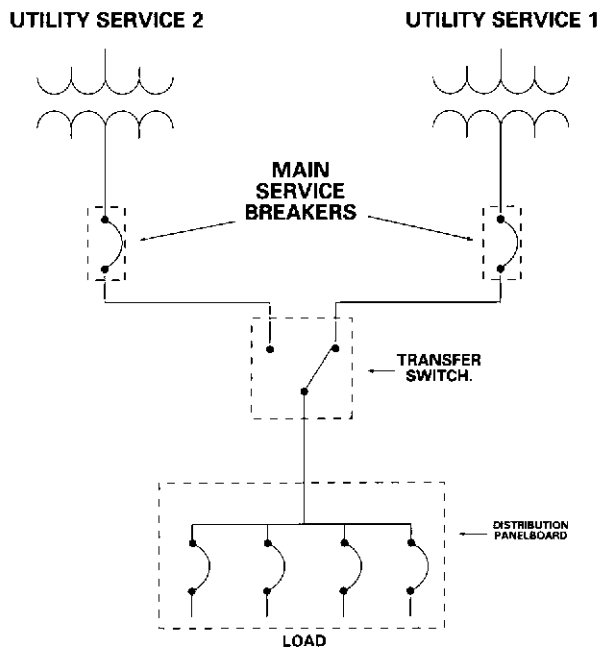

Illustrations depict stand alone transfer switches. Westinghouse switches can also be supplied in Pow-R-I, Pow-RMS Switchgear, Pow-R Line C Switchboards, Series 2100 Motor Control Centers, and DS Switchgear.

Please contact your local Westinghouse representative for more information.



Transfer Switch Equipment 30 through 4000A

A

TYPICAL TRANSFER SWITCH APPLICATIONS

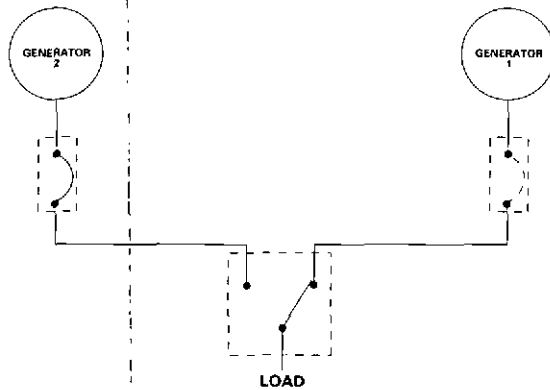

Dual Generator Sources

Some installations employing onsite power generation for both prime and standby service may use transfer switch equipment to alternately switch between such sources.

Fig.3

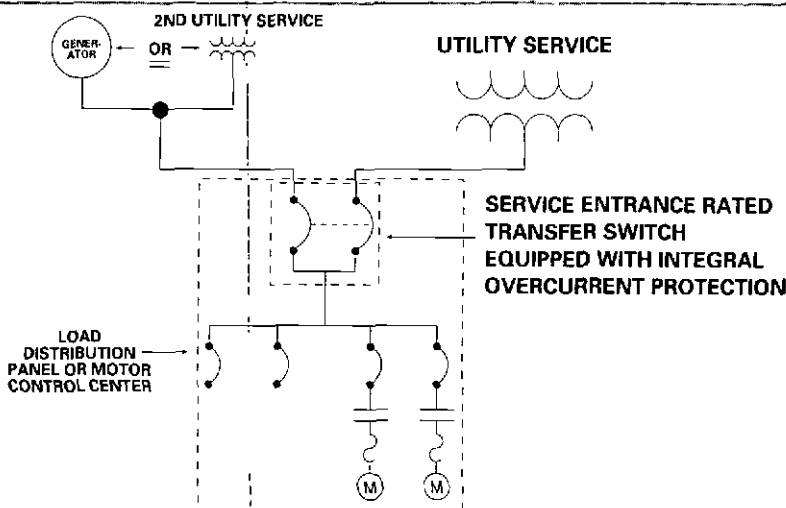

Service Entrance Transfer Switch

Often it is desirable to apply the transfer switch as a service equipment device thereby eliminating the need for separate service disconnects and overcurrent protective devices. This switch is particularly adaptable to waste water and water treatment plants, pumping stations, industrial plants, telecommunications facilities and other installations where all of the loads are critical in nature and need to be backed up by an alternate power source.

Fig.4

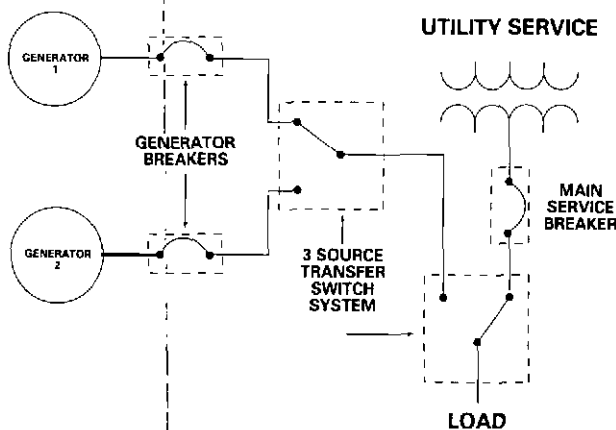

Utility Service - Dual Standby Generators (3 Power Sources)

Installations, where extremely critical loads may require a second back-up standby power source, utilize a 3-source transfer switch system.

Fig.5



Transfer Switch Equipment 30 through 4000A

Quick-Ship Automatic Transfer Switches

A

Even the best service in the industry cannot meet every emergency that may arise. That's why Westinghouse has a Quick-Ship Program. These are Transfer Switches that are **available from stock**.

All Quick-Ship Transfer Switches are Type 1 Enclosed, 3-pole, Solid State Logic Automatic Transfer Switches which include all the standard features plus Option Group 9. **They can be applied on any system voltage in the world with a simple change to the rating plug.**

Ampere Rating	Style Number	Includes Options
100	693C999G01	1A-TDNE Adj. 1-60 sec.
150	693C999G02	2B-TDES Adj. .5-15 min.
225	693C999G03	3C-TDEN Adj. .2-30 min.
300	693C999G04	4C-TDEC Adj. .2-30 min.
400	693C999G05	5B-Voltage/Frequency Sensing of emergency source
600	693C999G06	12C-Normal Position Light
800	693C999G07	12D-Emergency Position Light
1000	693C999G08	14C-Relay Aux. Contacts Normal 14D-Relay Aux. Contacts Emergency

The Westinghouse Technical Support Hotline 1-800/354-2070 will connect you to our factory-based application engineers 24 hours/day, 365 days/year. Our Product Specialists can provide invaluable on-the-spot expertise in such areas as:

- Transfer Switch application and stand by system design
- Installation/Start-up assistance
- Field problem analysis/identification and repair advice
- Replacement part identification with same-day shipment
- Expediting same or next-day field service when necessary

In addition to our factory technical support team, Westinghouse offers its Transfer Switch users an extensive worldwide network of field service locations manned 24 hours/day by factory trained service technicians just a telephone call away from even the most remote installation location. Each field service location is capable of offering a full range of services including:

- On-site start-up and installation
- Expanded maintenance and warranty service
- On-site problem identification and repair
- Field upgrade and retrofit



Service and Engineering Support

Call: 1-800-354-2070 (in Kentucky: 1-606-878-6100) for Factory Technical Assistance



Transfer Switch Equipment 30 through 4000A

Westinghouse Electric Corporation ATS Quality Assurance Certificate

A

Shop Order: _____ Tested By: _____
Serial Number: _____ Inspected By: _____

- I. Insulation Check (2200 volts for 3 seconds.)
 1. Transformer primaries and secondaries to ground. ()
 2. Secondary transformer winding - one to the other. ()
 3. When transformers are not used, check control wiring to ground and phase to phase. ()
 4. Motor windings to ground (900 volts.) ()
- II. Visual Inspection.
 1. Verify transformer taps wired for specified system voltage and frequency. ()
 2. Verify that catalog number, nameplates, and wiring diagrams match order write-up. ()
 3. Check for loose wire connections. ()
 4. Verify that wiring and paint finishes are neat and orderly. ()
 5. Check enclosure type and color with order write-up.
 - Open ()
 - Nema 1 ()
 - Nema 3R ()
 - Nema 12 ()
- III. Mechanical Tests (Switch in vertical position.)
 1. Apply rated voltage to both normal and emergency line terminals and verify correct input to each voltage sensing relay. Simulate field operation by removing normal power and applying emergency power. Switch should transfer to emergency. Reapply normal power - switch should retransfer to the normal position. Repeat the cycle 50 times. ()
 2. Verify that contacts close in each position. ()
 3. Check all auxiliary and limit switches in both normal and emergency positions. ()
 4. Check mechanical interlock with switch in both normal and emergency positions for freedom of movement and proper adjustment. ()
 5. Verify that operating mechanism is timed properly. ()
 6. Verify that mechanism does not overtravel or bind. ()
 7. If option 16 is supplied, manually operate switch to verify that breakers will reset from the tripped position. ()
- IV. Electrical Tests (Switch in vertical position)
 1. Turn on normal power; switch must transfer to normal if not already there. Turn normal off. ()
 2. Turn on emergency power; switch must transfer to emergency. ()
 3. With emergency power on, restore normal power; switch must return to normal position. ()
 4. Verify that switch will transfer from normal to emergency under the following conditions:
 - A. Loss of voltage in any phase. ()
 - B. If voltage in any phase falls below 70%. ()
 5. Verify that switch will return to normal when normal voltage reaches 90% of rating. ()
 6. Record final settings:
 - Pick-up _____% Drop-out _____%
 7. Check engine start contact for proper operation ()
 8. List options supplied. Verify proper operation of each. Set all time delays as necessary. Check for proper voltage and frequency ratings.
 - A. Option ()
 - B. Option ()
 - C. Option ()
 - D. Option ()
 - E. Option ()
 - F. Option ()
 - G. Option ()
 - H. Option ()
 - I. Option ()
 - J. Option ()
 - K. Option ()
 - L. Option ()



Units are cycled 50 times by alternately removing normal and emergency power sources.

Westinghouse thoroughly tests every transfer switch that is built. The tests that are performed are verified by the tester and results are shipped with each switch.

Insulation Check: Ensures the integrity of insulation and continuity of the entire system.

Visual Inspection: Ensures that the switch matches the customer requirements and verifies that the fit and finish meet Westinghouse quality standards.

Mechanical Tests: Verifies that the switch's logic and power sections work together and are free of mechanical hindrances.

Electrical Tests: Verifies the complete electrical operation of the switch and sets up the time delays and voltage sensing settings of the logic.



Transfer Switch Equipment 30 through 4000A

Solid State Logic for Automatic and Non-Automatic Switches

Westinghouse offers two types of logic panels which are used in conjunction with the power switching panel to achieve completely automatic operation or non-automatic operation as required. Both logic panels share the following standard features:

B

- Engine contacts wired to red color-coded terminal blocks for easy identification of customer connection.
- Limitless combinations of options available for superior flexibility in addressing the most demanding job application.
- Logic panel interconnects with power switching panel via keyed plug connectors to permit total isolation of controls for maintenance purposes.
- All wiring hot ink stamped with designations corresponding to wiring diagram supplied with each unit.
- Wiring to external pilot devices or for customer connections is brought out to clearly identified terminal blocks.
- Solid neutral bar supplied as standard on all 2 & 3 pole units.

Solid State Logic - 100-4000Amps
2,3,4 Poles
(for use with switch catalog numbers ATSBM,ATSRM,ATSBI,ATSRD, MTSRM, and MTSBM)

The Westinghouse Solid State Logic is a highly reliable, flexible intelligence system designed to comply with your most demanding standby power application. This field-proven logic provides the ultimate in protection against power interruption by use of precision calibrated solid state components.

Universal Multi-Tap
Voltage Selection

Modular Solid State
Logic Cards

Time Delay Engine
Start Timer

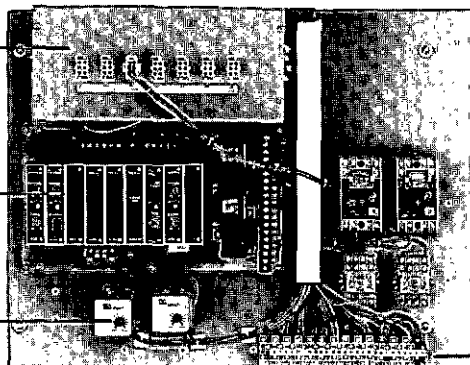

Engine
Start
Contact

Typical Solid State Logic (Shown with Options)

Features

- Complete 3 phase,close differential undervoltage sensing of normal source is standard. Normally set at 70% dropout, 90% pickup and field adjustable for alternate settings.
- Most optional sensing and timing functions performed by plug-in printed circuit cards (options 1,3,4,5 & 26).
- Solid state cards come equipped with lockable adjustment knobs and L.E.D. indicators for ease of field settings and diagnostics.
- Sensing cards (voltage and frequency) and timing cards are interchangeable by function, but are keyed to prevent improper insertion of card of dissimilar function (i.e. timing card in sensing card slot).
- Multi-tap transformer package permits line voltage selection of 208, 220, 240, 380, 415, 480, or 600 volts AC, 50 to 60 Hz simply by proper insertion of voltage selection plug.

- Options 2,30,32, and 35 performed by clearly marked solid state panel-mounted timers with 10 amp contact ratings.
- Wide range of field installable option kits available with retention of UL label.

Benefits

- Flexible adjustable settings for ease of applying to specific application needs. Settings can be locked in to prevent tampering.
- Key interlocked cards to prevent improper insertion.
- Modular design eases preventive maintenance and adapting to new application requirements.
- Provides the ultimate in transient isolation protection and versatility in application set-up. Meets IEEE surge withstand requirements.

Solid State Logic Control Panel

Solid State Logic Panel - 100-1000 Amperes, 2, 3, 4, Poles
Automatic and Non-Automatic Transfer Switches

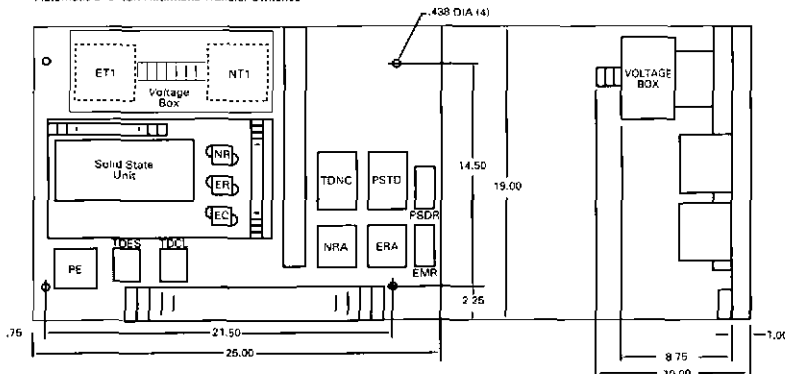



Transfer Switch Equipment 30 through 4000A

Relay Logic Available on switches 30-600A

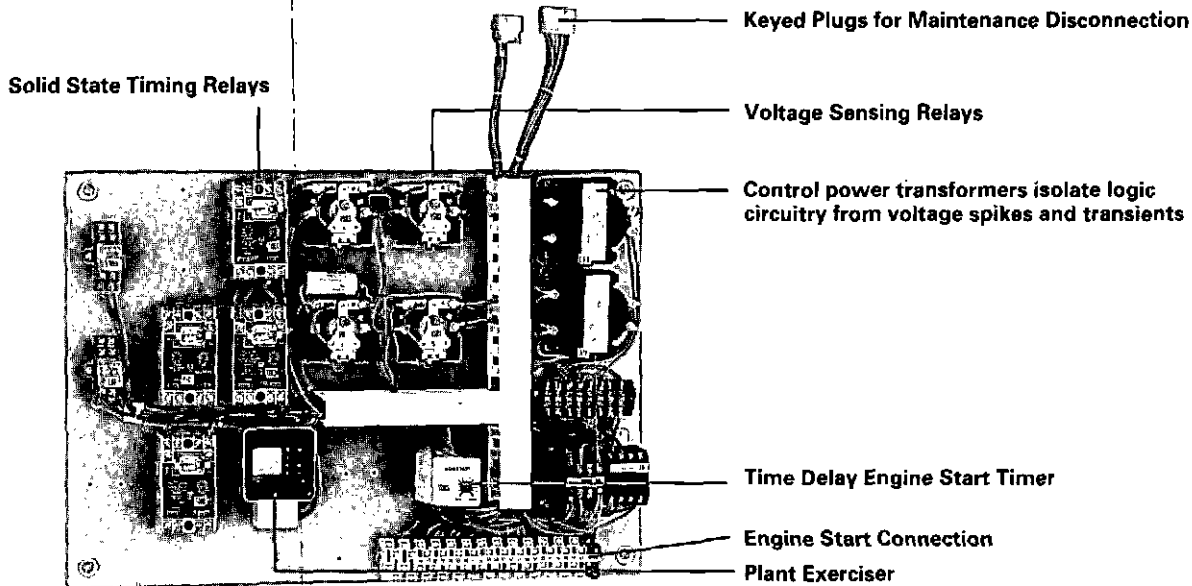

B

Typical Relay Logic (Shown with Options)

Features

- Complete full phase undervoltage sensing of normal source via panel mounted relays is standard. Normally set and fixed at 75% dropout, 85% pickup.
- Optional sensing and timing functions performed by clearly marked panel mounted type relays with 10 amp contact ratings.
- The same full range of option additions are available with the relay logic design as with solid state logic.
- Simple, straightforward relay logic simplifies field installation and diagnostics.

Benefits

- Reliable design suitable for environments requiring low maintenance.
- Can accommodate a wide variety of transfer switch applications.
- Eases troubleshooting and maintenance.

Relay Logic Control Panel

Electromechanical Logic Panel - 30-400 Amperes, 2, 3, 4 Poles
Automatic Switches Only

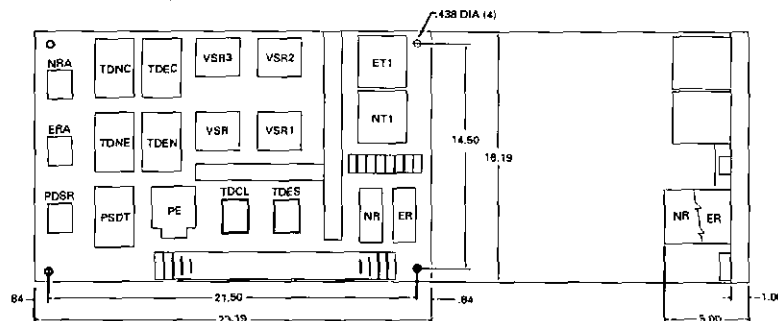

Approximate Shipping Weight - 30 lbs.



Transfer Switch Equipment

30 through 4000A

Automatic Transfer Switches — Type ATSBM Solid State Logic 100 - 1000 amps

The ATSBM Series of Transfer Switches provide the specifying engineer and the ultimate customer with the most flexible switch available for complete system load transfer. The power panel utilizes molded case switches specifically designed for transfer switch application. The solid state logic panel and its wide array of options maximizes system versatility. This makes the ATSBM Series the choice for requirements through 1000 amps.

C

Transfer Switch Catalog Number Explanation

	No. of Switched Poles	Ampere Rating	Voltage	Enclosure
ATSBM - Solid State Logic Automatic Transfer Switch (100-1000A)	3	0225	X	K
	2 - 2 Pole	0100 - 100 Amp	A - 120/60	K - Open
	3 - 3 Pole	0150 - 150 Amp	B - 208/60	S - Nema 1
	4 - 4 Pole	0225 - 225 Amp	W - 240/60	J - Nema 12
		0300 - 300 Amp	X - 480/60	R - Nema 3R
		0400 - 400 Amp	E - 600/60	L - Nema 4 ¹
		0600 - 600 Amp	G - 220/50/60	D - Nema 4 X ¹
		0800 - 800 Amp	M - 230/50	
		1000 - 1000 Amp	Z - 365/60	
			H - 380/50	
			N - 401/50	
			O - 415/50	
			K - 600/50	

¹ Call Factory for Dimensions.

Features

- Solid state logic panel.
- Molded case switch power contact assemblies.
- Permanently affixed safe manual operating handle.
- Quick keyed disconnect plug between power switching panel and logic panel.
- Three levels of interlocking; two mechanical interlocks and one electrical interlock.
- High withstand, closing and interrupting ratings.
- High pressure, silver alloy weld resistant contact structures.
- Air Break Deion arc quenching.

Benefits

- Reliable and versatile systems monitoring and interaction with all transfer switch functions. Offers wide array of options for customer design flexibility.
- High withstand switching devices, totally enclosed for maximum arc suppression and isolation during power transfer. Optional trip units offer system overcurrent protection.
- Permits true quick break, quick make manual operation under full load. Operation under load is completely safe to personnel and equipment.
- Provides safe, positive disconnection for electrical isolation of the logic circuits for maintenance or manual operation.
- Redundant interlocking affords the safest possible installation to positively prevent paralleling of two sources of power.

For Withstand, Closing and Interrupting Ratings, Circuit Breaker and Fuse Coordination, see page 14.



Transfer Switch Equipment 30 through 4000A

Three Levels of Interlocking

- Operating Mechanism
- Walking Beam Interlock
- Electrical Interlock

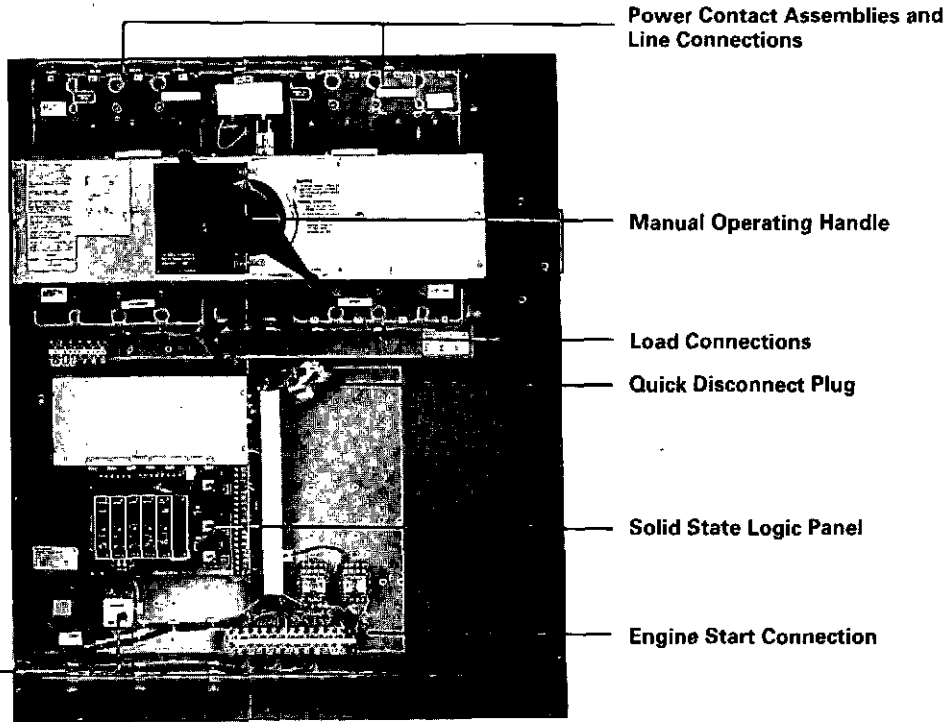

C

Enclosed Unit Dimensions

NEMA 1, 3R & 12 Enclosures^② 100-1000 Amperes, 2, 3, 4 Poles

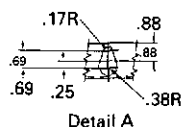
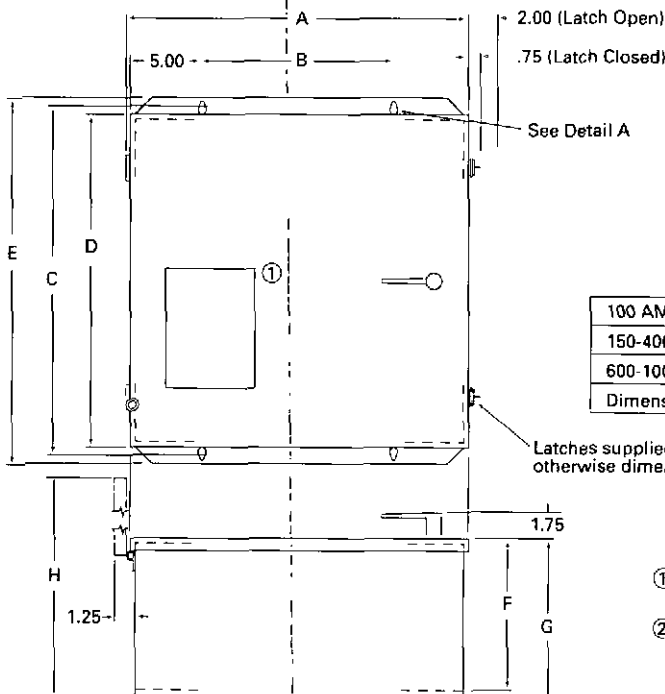

	Approximate Shipping Weight (lbs.)
100 Amps	195
150-300 Amps	425
400 Amps	450
600 Amps	550
800-1000 Amps	625

Note: Add 10% for 4 Pole Units.

	A	B	C	D	E	F	G	H
100 AMP	28.88	19.13	39.74	39.62	41.50	9.72	10.22	38.25
150-400 AMP	38.88	29.13	49.74	49.62	51.50	17.28	17.78	55.81
600-1000 AMP	38.88	29.13	59.74	59.62	61.50	17.28	17.78	55.81

Dimensions for MTSRM are same as ATSRM - page - 13

Latches supplied on NEMA 12 & 3R only otherwise dimensions same as NEMA 1

① Device panel supplied to house required pilot control devices (lights, selector switches, etc.)

② Call Factory for Dimensions of Type 4 Enclosures



Transfer Switch Equipment

30 through 4000A

SPB Transfer Switches - Type ATSRM Solid State Logic 1200-4000 AMPS

The Westinghouse SPB Transfer Switch represents the latest in transfer switching technology. The fast-acting stored energy mechanism and high withstand ratings make it ideally suited for the transfer of critical electrical loads in emergency/standby, dual generator, load shedding, peak shaving and cogeneration control systems. It can fully coordinate with any upstream power breaker's short time delay protection.

Transfer Switch Catalog Number Explanation

	No. of Switched Poles	Ampere Rating	Voltage	Enclosure
ATSRM - SPB Automatic Transfer Switch Solid State Logic (1200-4000A)	4	3000	X	S
	2 - 2 Pole	1200 - 1200 Amp	A - 120/60	K - OPEN
	3 - 3 Pole	1600 - 1600 Amp	B - 208/60	S - NEMA 1
	4 - 4 Pole	2000 - 2000 Amp	W - 240/60	R - NEMA 3R
		2500 - 2500 Amp	X - 480/60	
		3000 - 3000 Amp	E - 600/60	
		* 4000 - 4000 Amp	G - 220/50/60	
			M - 230/50	
			Z - 365/60	
			H - 380/50	
			N - 401/50	
			O - 415/50	
			K - 600/50	

*Available as 3 pole unit only.

Features

- Complies with UL 1008, UL 1087 and UL 489 standards.
- High withstand, totally enclosed Pow-R switches.
- High speed, stored energy switching mechanism.
- Mechanical and electrical interlocking.
- Fully rated true 4th pole on common shaft.
- Westinghouse close differential sensing logic.

Benefits

- The endurance and interrupting requirements of the combined standards provide the engineer with the assurance of safe and reliable operation.
- Provides the maximum arc suppression and isolation during power transfer.
- Provides the fastest switching times available, (less than 5 cycles.)
- Ensures that the sources will not be paralleled.
- Provides 4-pole switching for systems where switching

Standard Withstand, Closing and Interrupting Ratings^{(1) (2)}

Transfer Switch Amp Rating	Rating when used with upstream circuit breaker ⁽⁴⁾			Rating when used with upstream fuse ⁽⁴⁾		
	240V	480V	600V	Max Fuse Rating	Fuse Type	480V
1200	100	100	85	2000	L	200
1600	100	100	85	3000	L	200
2000	100	100	85	3000	L	200
2500	100	100	85	4000	L	200
3000	100	100	85	4000	L	200
4000	100	100	85	5000 ⁽³⁾	L	200

(1) Tested In Accordance with UL-1008.

(2) For Maximum breaker rating in circuits where the transfer switch is evaluated as a "motor branch circuit conductor" refer to the NEC Section 430-25 for sizing.

(3) Westinghouse Class L Fuse only for 5000A rating.

(4) All ratings are KA.



Transfer Switch Equipment 30 through 4000A

SPB Transfer Switches

Dimensions are approximate.
Should not be used for construction purposes.
Refer to Dimension Sheet 29-970 Pages 1-6.

4 pole 2000A Service Entrance Switch Shown

Enclosures for Systems Pow-R Switches

1200-2000 Amperes, 3, 4 Poles

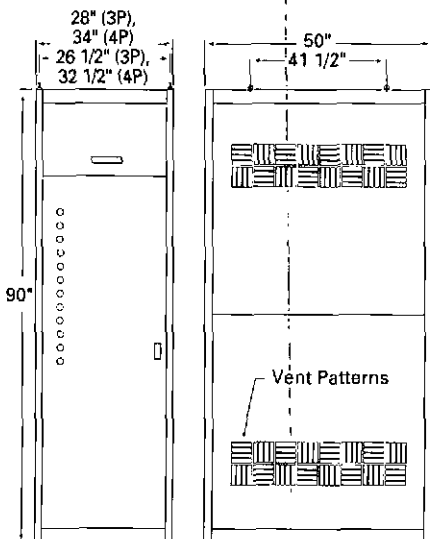

2500-4000 Amperes, 3 Poles
2500-3000 Amperes, 4 Poles

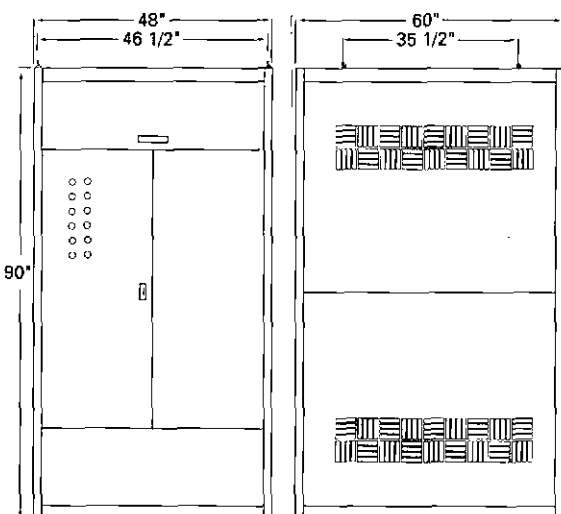

Conduit 3 & 4 Pole 1200-4000 Amps

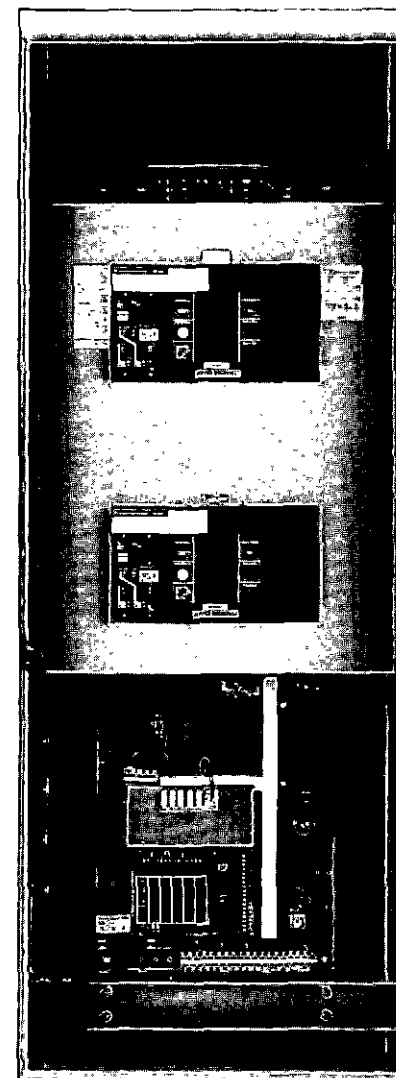
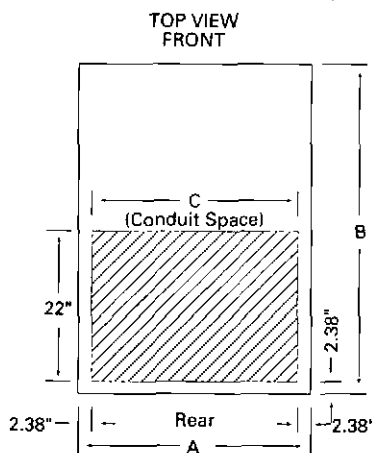

Transfer Switch can be mounted in corner or against a wall - access to cable space can be via either side or the rear.

	A	B	C	Approximate Shipping Weight (lbs)
3 Pole, 1200-2000A	28	50	23.5	1300
4 Pole, 1200-2000A	34	50	29.5	1400
3, 4 Pole 2500-3000A	48	60	43.25	1900
3 Pole 4000A				2100

Note: When Open Switch is Mounted in Customer Enclosure, a Vent Pattern Similar to that used on Westinghouse Enclosure must be utilized. See SPB Enclosure Drawing 1368D63.



Transfer Switch Equipment

30 through 4000A

SPB Drawout Transfer Switches - Type ATSRD and MTSRD Solid State Logic 800 - 4000 Amps

Westinghouse Drawout Transfer Switches are designed for applications where preventive maintenance, inspection, and/or testing must be accomplished while maintaining continuity of power to the load. This design is typically used in critical life safety/support systems and power situations that require safe maintenance of the system without lengthy disruption of power.

Westinghouse Drawout Transfer Switches meet or exceed all industry standards for endurance, reliability and performance. They are listed under Underwriters Laboratory's UL 1008 Standard for Safety for Transfer Switch Equipment. They also comply with emergency and standby system requirements as defined in NFPA 110, NEC Article 700 and meet the basic requirements of NFPA 99 for health care facilities. [Catalog Number Chart]

C

Transfer Switch Catalog Number Explanation

Switch Type	No. of Switched Poles	Switch Rating	Phase to Phase Voltage/Frequency	Enclosure Type
ATSRD - Automatic Transfer Switch	2 - 2 Pole	800 - 800 Amp	A - 120/60	S - Type 1
	3 - 3 Pole	1000 - 1000 Amp	B - 208/60	R - Type 3R
	4 - 4 Pole	1200 - 1200 Amp	W - 240/60	Type 12
MTSRD - Non-Automatic Transfer Switch		1600 - 1600 Amp	X - 480/60	
		2000 - 2000 Amp	E - 600/60	
		2500 - 2500 Amp	G - 220/60/50	
		3000 - 3000 Amp	M - 230/50	
		4000 - 4000 Amp	Z - 365/50	
BTSRD - Basic Transfer Switch (no logic included)			H - 380/50	
			N - 401/50	
			O - 415/50	
			K - 600/50	

Features

- Superior Main Contact Structure
- Reliable Solid State Logic
- Ease of Operation
- Ease of Coordination

Benefits

The Westinghouse Drawout Transfer Switch meets or exceeds the standards set forth in UL 1008, UL 1087 and UL 489. No other transfer switch manufacturer has met the rigid testing requirements of this combination of standards. Completely enclosed contacts add a measure of safety and reliability. It also insures the integrity of the contact assemblies and minimizes the need for periodic maintenance of the contacts, reducing downtime and maintenance costs.

The intelligence panel utilizes the reliable, close differential sensing Westinghouse Modular Solid State Logic Package. This give the systems designer the opportunity to tailor the product to any particular application as well as providing the capability of upgrading logic components in the field as needed.

The Westinghouse Drawout Transfer Switch utilizes Systems Pow - R Breaker Drawout Cassettes for mounting of the molded case switches. This design allows for quick removal of the switches for inspection or maintenance, or if required, quick replacement.

The Westinghouse Drawout Transfer Switch is easily coordinated with any system power or air circuit breaker. The SPB switches can withstand a short circuit for up to 60 cycles. Typical Drawout Transfer Switch Applications

Functional Features

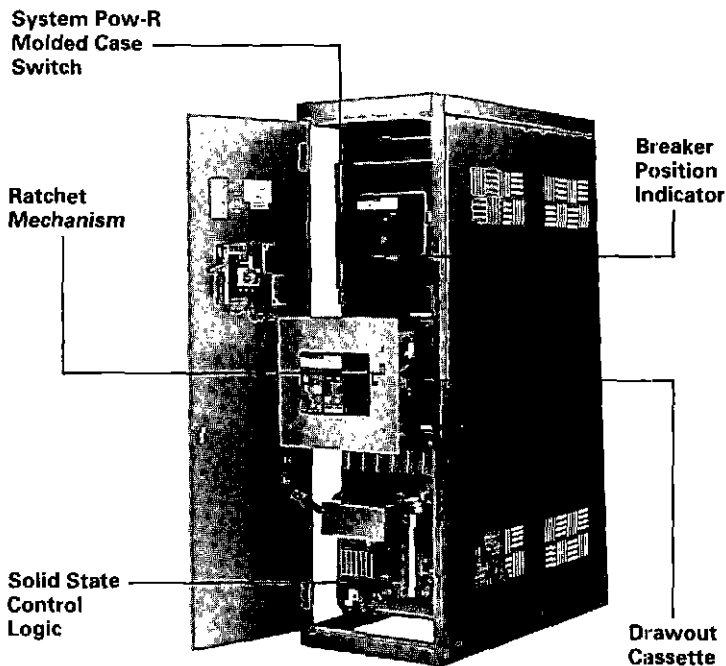



Transfer Switch Equipment 30 through 4000A

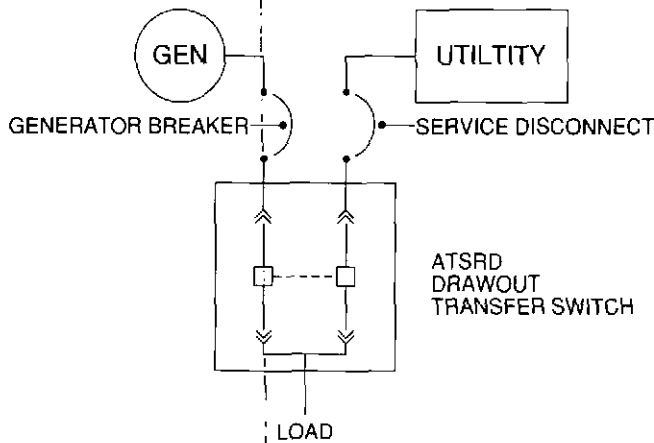

Fig. 1 Standard Application

The most common application of Transfer Switch Equipment involves switching of critical loads from a preferred utility service to an onsite, engine driven generator power source.

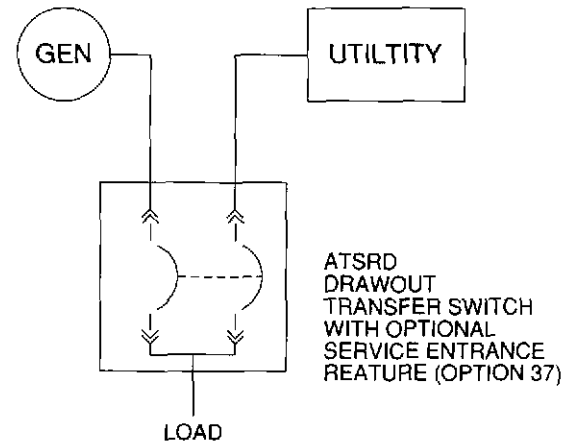

Fig. 2. Service Entrance Transfer Switch

Often it is desirable to apply the transfer switch as a service equipment device thereby eliminating the need for separate service disconnects and overcurrent protective devices. This switch is particularly adaptable to waste water and water treatment plants, pumping stations, industrial plants, telecommunications facilities and other installations where all of the loads are critical in nature and need to be backed up by an alternate power source.

The Westinghouse ATSRD Comes With The Following Standard Features And Accessories

- **Test Selector Switch** - Provides a spring released pushbutton for test operation of the ATS. It simulates a loss of the normal power source, initiates an engine start and transfers the load to the emergency/standby power source.
- **Engine Starting Contact** - Provides a 10A, 30 VDC contact closure to initiate engine starting upon failure of the normal power source. This feature, specifically designed for low current applications, is wired to red terminal blocks on the control panel for ease of identification and maintenance.
- **Full Phase Protection** - Provides phase failure protection on each phase of the normal power/supply. Should the voltage drop below a pre-selected, fully adjustable value on any phase, a signal is sent to initiate engine start.
- **Time Delay Normal To Emergency** - Provides a delay, adjustable 1 - 60 seconds, when transferring from the normal power source to the emergency power source. This accessory does not affect the engine starting circuit. Timing begins when emergency/standby voltage appears.
- **Time Delay Engine Start** - This accessory is used when the emergency power source is an engine generator. It delays initiation of the engine start circuit for 5 - 15 seconds (adjustable) in order to override momentary power outages or voltage fluctuations of the normal power source.
- **Time Delay Emergency To Normal** - Delays the retransfer from the emergency/standby power source to the normal power source to permit stabilization of the normal power source before retransfer is made. Timing is adjustable 2 - 30 minutes and begins when the normal power source appears. If the emergency/standby power source fails during timing, retransfer to the normal power source is immediate, overriding the time delay.
- **Time Delay Engine Cooldown** - Permits the engine to continue to run unloaded after retransfer to the normal power source has been made. Timing is adjustable 2 - 30 minutes and begins when retransfer is completed.
- **Full Rated Neutral** - Provides a fully rated solid neutral for all two and three pole switches. All four pole switches are supplied with

- switched neutral contacts of identical construction and rating as the power poles and are mounted on the power contact shaft integral to the completely enclosed contact assemblies.
- **Multi - Tap Voltage Selection** - Provides line voltage selection of 209, 220, 240, 380, 415, 480 or 600 volts AC, 50 to 60 Hz by proper insertion of voltage selection plug.
- **Emergency/Standby Source Monitoring** - Relay monitor prevents transfer from the normal power source to the emergency/standby power source until that source has attained 90% of nominal voltage and frequency. In addition, when the switch is in the emergency/standby position and that source falls outside the monitor parameters, a load retransfer is initiated to the normal power source if it is present.
- **Indicating Lights** - Indicate switch position. Green for normal position, red for emergency/standby position.
- **Relay Auxiliary Contacts** - Provides 3 Form C contacts for each source. On the normal power source, energized when the load is connected to the normal power supply and normal voltage is present. On the emergency/standby power source, energized whenever emergency/standby voltage is present.

C



Transfer Switch Equipment 30 through 4000A

Dimensions, Enclosed Units

All Westinghouse enclosures are constructed of high quality, 12 gauge steel and include a key lockable door handle as standard equipment. Enclosures for Westinghouse Type ATSRD Switches are freestanding Type 1 or Type 3R, and meet all current applicable NEMA and UL

standards for conduit entry, cable bending, gutter space, and shielding of live components. See chart below for approximate enclosure dimensions.

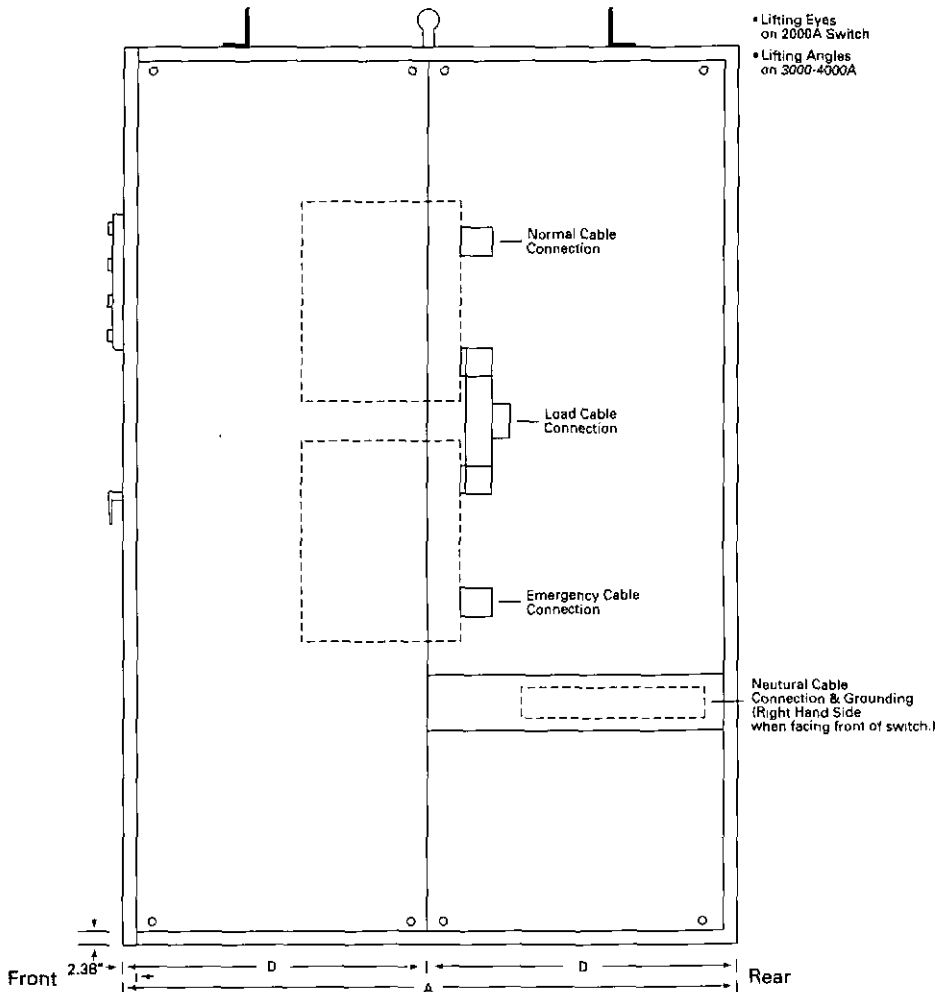

Rating	Depth	
	A	D
800-2000A	60.00	30.00
2500-4000A	72.00	36.00

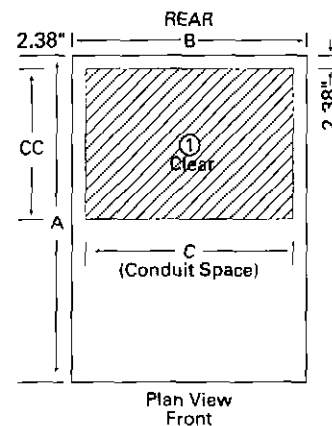

Dimensions Conduit Opening ATSRD Switches	A	B	C	CC Cable Space Depth	Weight (lbs.)
3 Pole, 800-2000A	60"	28"	23.24	28.44	1650
4 Pole, 800-2000A	60"	34"	29.24	28.44	1900
3 Pole 2500-4000A	72"	48"	43.24	33.84	2200
4 Pole 2500-3000A	72"	48"	43.24	29.62	2400

① Clear Area assumes no floor channels used under the frame members.



Transfer Switch Equipment 30 through 4000A

Typical Specifications For Westinghouse Electric Corporation Type ATSRD Drawout Transfer Switch 800 4000 Amperes

1.0 General

- 1.1 Furnish and install where indicated Transfer Switches having the Ratings, Features/Accessories, Enclosures, etc. indicated on the drawings or noted herein.
- 1.2 Transfer Switches and Features/Accessories shall be manufactured by Westinghouse Electric Corporation.

2.0 Ratings

- 2.1 The Transfer Switches specified herein shall be rated as shown on the drawings. All 3 phase 4 wire Transfer Switches used with ground fault equipment shall be the true 4 pole switched neutral type with all four poles for each source being fully rated and connected to a common shaft.
- 2.2 The Transfer Switches shall be rated for non-welding of contacts when used with the upstream overcurrent protective devices shown on the plans and with the available fault current specified herein.
- 2.3 The withstand, interrupting and closing current ratings of the Transfer Switches shall be no less than those required to be compatible with the available system short circuit and the type and rating of systems protective devices and shall have a 60 cycle withstand rating of 51KA on 800-3000 and 85KA on 4000 amp switches.
- 2.4 The transfer switches shall be 100% equipment rated and shall conform to the requirements of UL1008. All transfer switches shall bear the UL1008 label.
- 2.5 All switches shall be 600V class equipment.

3.0 Construction

- 3.1 Transfer Switches specified herein shall consist of completely enclosed contact assemblies and a separate control logic panel. The contact assemblies shall be operated by a stored energy mechanism and be energized only momentarily during transfer providing inherently double throw switching action. Control power for all transfer operations shall be derived from the line side of the source to which the load is being transferred.
- 3.2 Transfer Switches shall be capable of being operated manually under full load conditions. Manual operation shall be accomplished via integrally mounted pushbutton operators located on the face of the contact assemblies. Removeable manual operating handles and handles which will move in the event electrical operators should suddenly become energized while performing a manual transfer operation are not acceptable. In addition, provisions should be provided to allow disengagement of the electrical operator during manual operation.
- 3.3 The Transfer Switches shall be positively interlocked mechanically and electrically to prevent simultaneous closing of both sources under either automatic or manual operation. A neutral position shall not be possible under normal electrical operation unless a delayed transition accessory is required for switching highly inductive loads. The Transfer Switches shall have a manual neutral position for load circuit maintenance. A position indicator shall be visible from the front of the switch to show to which source the Transfer Switch is connected.
- 3.4 The Transfer Switches shall be provided with a drawout mechanism to allow easy access to the molded case switches/breakers for preventive maintenance, testing or inspection. The drawout mechanism shall provide visual indicators as to position of switch/breaker during the drawout operation.
- 3.5 Inspection and replacement of all separate arcing contacts (moving and stationary) shall be possible from the front of the Transfer Switch.
- 3.6 A solid state sensing and control logic panel shall be separately mounted from the power switching portion of the Transfer Switch. The two sections shall be connected together by control cables with plug-in connectors. The control section shall be capable of being disconnected from the power section for maintenance purposes.

- 3.7 The logic circuit shall utilize solid state components mounted on printed circuit boards to accomplish proper operation, wherever practical, to perform functions such as timing, voltage and frequency monitoring. LEDs shall be furnished to indicate the operation of each function furnished. Construction shall be such that functions are individually replaceable without requiring replacement of the complete solid state package. Plug-in modifications shall be available for field installation with retention of the UL label.
- 3.8 The Transfer Switch shall be equipped with a voltage selection plug making it suitable for operation on any voltage from 208 through 600 volts AC, 50 or 60 Hertz, by placing the voltage selection plug in the proper voltage receptacle. Covers shall be used to block off the unused receptacles.
- 3.9 Each Transfer Switch shall be supplied in the appropriate enclosure as shown on the plans. The enclosure shall be painted with the manufacturer's standard painting procedures to insure suitability for environmental conditions as referred in the plans. The contractor's field wiring terminations within the enclosure shall comply with NFPA 70. If wiring is not color coded, wires shall be permanently marked near the terminal at each end with the wire number shown on the approved shop drawings. Terminal blocks shall conform to NEMA ICS 4. Main transfer switch terminals shall be suitable for the termination of conductors shown on the plans.

4.0 Sequence of Operation

- 4.1 Upon loss of phase-to-phase voltage of the normal source to 70% of nominal, and after a time delay of .5-15 seconds (adjustable to meet conditions present) to override momentary dips and/or outages, a 10 ampere, 30VDC contact shall close to initiate starting of the Emergency/Standby Source power plant. Transfer to the alternate source shall take place immediately upon attainment of 90% of rated voltage and frequency of that source. For switches not involving engine generator sets as power plants, transfer shall occur after an adjustable time delay of 1-60 seconds to override momentary dips and outages.
- 4.2 When the Normal Source has been restored to 90% of rated voltage, and after a time delay adjustable from .2-30 minutes (to insure the integrity of the Normal Power Source), the load shall be retransferred to the Normal Source.
- 4.3 A time delay, adjustable .2-30 minutes, shall delay shutdown of the Emergency/Standby Power Source after retransfer to allow the generator to run unloaded for cool-down, after which the generator shall shut down.
- 4.4 If the Emergency/Standby power plant should fail while carrying the load, transfer to the Normal Power supply shall be made instantaneously upon restoration of the Normal Source to satisfactory conditions.

5.0 Features/Accessories

The following Features/Accessories shall be supplied:

- 5.1 Auto/Test Switch to provide test operation of the Transfer Switch by simulating a loss of Normal Power Source.
- 5.2 Pilot lights to indicate to which source the load is connected.
- 5.3 Relay auxiliary contacts (2NO, 2NC) to indicated Transfer Switch position and integrity of each source.
- 5.4 Plant Exerciser Timer providing automatic test operation of the Emergency/Standby Power Source at pre-selected intervals (adjustable 0-168 hours in multiples of 15 minutes) at least once per week.
- 5.5 Hand held test kit for field testing and calibration of all plug-in timing and monitoring cards, as well as the output relays from the solid-state logic panel.

6.0 Installation

- 6.1 Installation of all Transfer Switches specified herein shall be in accordance with all applicable codes, standards, and practices.
- 6.2 Installation of all Transfer Switches specified herein shall be in accordance with the recommendations of the manufacturer.

C



Transfer Switch Equipment

30 through 4000A

Automatic Transfer Switches — Type ATSBP

Relay Logic 30-600 Amps

The Westinghouse Relay Logic is a reliable system for those applications that require low maintenance or where a harsh environment may favor simpler to maintain logic.

Transfer Switch Catalog Number Explanation

	No. of Switched Poles	Ampere Rating	Voltage 60 Hz Only	Enclosure
ATSBP - Relay Logic Transfer Switch (30-1000A)	3	0225	X	K
	2 - 2 Pole	0030 - 30 Amp	A - 120/60	K - Open
	3 - 3 Pole	0070 - 70 Amp	B - 208/60	S - Nema 1
	4 - 4 Pole	0100 - 100 Amp	G - 220/60	J - Nema 12
		0150 - 150 Amp	W - 240/60	R - Nema 3R
		0225 - 225 Amp	X - 480/60	
		0300 - 300 Amp	E - 600/60	
		0400 - 400 Amp		
		0600 - 600 Amp		

Features

- Interconnection between switching and intelligence panels made via control plug connectors. Removal of plug isolates the intelligence panel.
- Complete 3 phase undervoltage sensing on normal source. Factory set at 70% dropout and 85% pickup.
- A multitude of different option combinations for sensing and timing functions.
- All customer control connections are easily accessible from the bottom of the power panel.
- Straightforward, uncomplex, relay logic.

Benefits

- Intelligence panel maintenance can be performed safely with no power connected.
- Provides complete undervoltage protection.
- Satisfies a wide range of application requirements.
- Easy connection to external circuits.
- Simplifies field installation and diagnostics.

Standard Withstand, Closing and Interrupting Ratings^{(1) (3)}

Transfer Switch Amp Rating	Rating when used with upstream circuit breaker ⁽⁵⁾			Rating when used with upstream fuse ⁽⁶⁾		
	240V	480V	600V	Max Fuse Rating	Fuse Type ⁽⁴⁾	480V
30	100	65	25	200	J,T	200
70	100	65	25	200	J,T	200
100	100	65	25	200	J,T	200
150	100	65	25	400	J,T	200
225	100	65	25	400	J,T	200
300	100	65	25	400	J,T	200
400	65	35	25	600	J,T	200
600	65	50 ⁽²⁾	25	800/1200	J,T	100/200

(1) Tested In Accordance with UL-1008.

(2) 4 Pole units are rated 35KA.

(3) For Maximum breaker rating in circuits where the transfer switch is evaluated as a "motor branch circuit conductor" refer to the NEC Section 430-25 for sizing.

(4) Also can use Class RK5 fuse with 100KA rating.

(5) All ratings are KA.



Transfer Switch Equipment 30 through 4000A

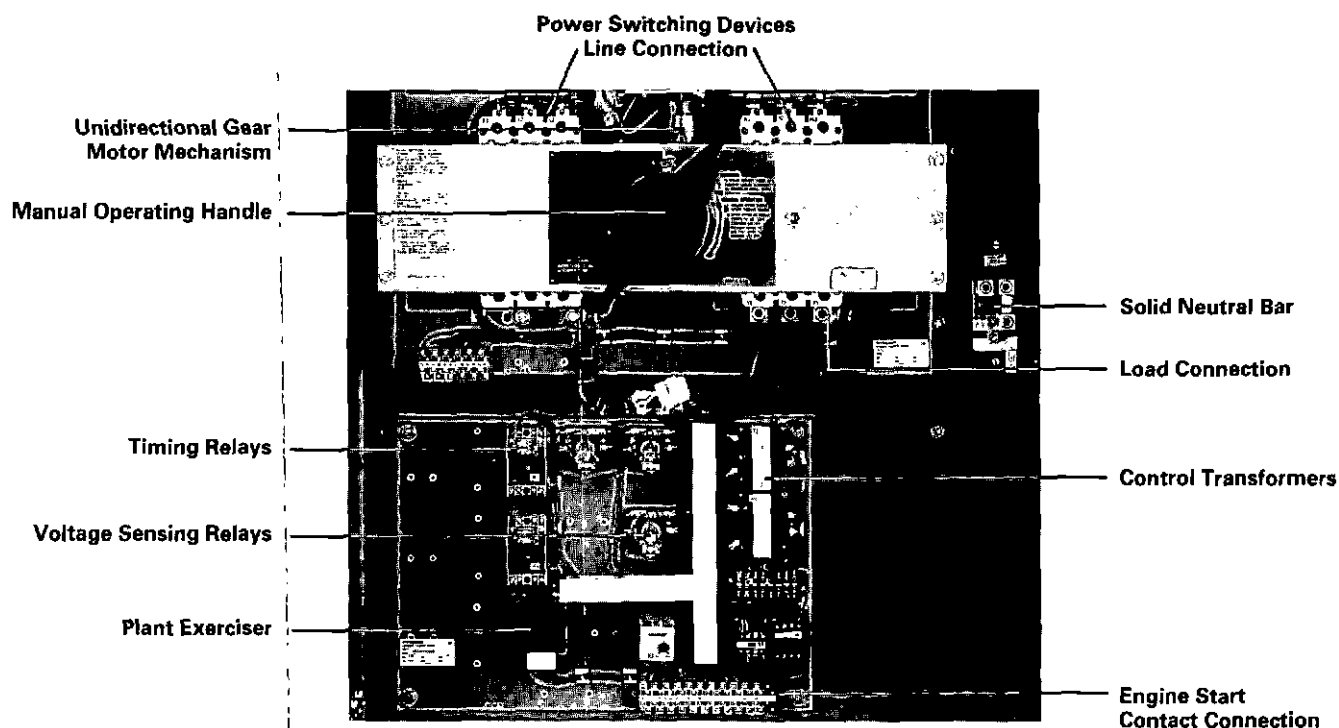

C

Dimensions, Enclosed Unit

NEMA 1, 3R & 12 Enclosures ② 30-1000 Ampere, 2, 3, 4 Poles

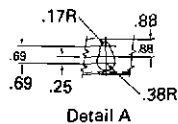
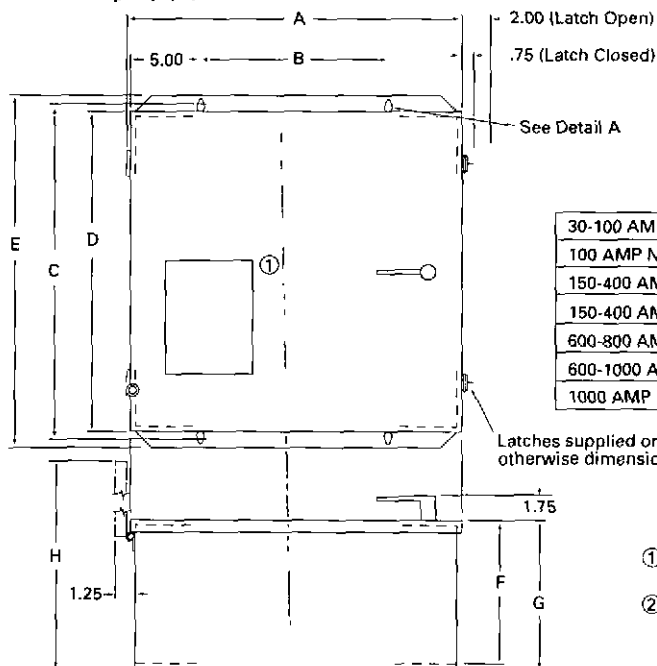

	Approximate Shipping Weight (lbs.) Manual Non-Automatic
100 Amps	195
150-300 Amps	425
400 Amps	450
600 Amps	550
800-1000 Amps	625

Note: Add 10% for 4 Pole Units.

	A	B	C	D	E	F	G	H
30-100 AMP Manual	22.88	13.13	22.74	22.62	24.50	9.78	10.28	32.31
100 AMP Non Automatic	28.88	19.13	39.74	39.62	41.50	9.72	10.22	38.25
150-400 AMP Manual	38.88	29.13	35.74	35.62	37.50	17.28	17.78	55.81
150-400 AMP Non Automatic	38.88	29.13	49.74	49.62	51.50	17.28	17.78	55.81
600-800 AMP Manual	38.88	29.13	49.74	49.62	51.50	17.28	17.78	55.81
600-1000 AMP Non Automatic	38.88	29.13	59.74	59.62	61.50	17.28	17.78	55.81
1000 AMP Manual	38.88	29.13	59.74	59.62	61.50	17.28	17.78	55.81

Latches supplied on NEMA 12 & 3R only
otherwise dimensions same as NEMA 1

- ① Device panel supplied to house required pilot control devices (lights, selector switches, etc.)
- ② Call Factory for Dimensions of Type 4 Enclosures



Transfer Switch Equipment

30 through 4000A

Non-Automatic Transfer Switches Electrically Operated Type MTSBM & MTSRM Manual Types MTSSM & MTSDM

The MTSBM, MTSRM, MTSSM and MTSDM series of transfer switches offer the customer non-automatic operation when fully automatic operation is not required. This can be specified in either electrically operated or manual configurations.

Transfer Switch Catalog Number Explanation

Type Switch	Construction	No. of Switched Poles	Ampere Rating	Voltage	Enclosure
M Manual	B Power Assisted Non-Automatic	3 2 - 2 Pole 3 - 3 Pole 4 - 4 Pole	0225 0100 - 100 Amp 0150 - 150 Amp 0225 - 225 Amp 0300 - 300 Amp 0400 - 400 Amp 0600 - 600 Amp 0800 - 800 Amp 1000 - 1000 Amp 1200 - 1200 Amp 1600 - 1200 Amp 2000 - 1200 Amp 2500 - 1200 Amp 3000 - 1200 Amp 4000 - 1200 Amp	X A - 120/60 B - 208/60 W - 240/60 X - 480/60 E - 600/60 G - 220/50/60 M - 230/50 Z - 365/60 H - 380/50 N - 401/50 O - 415/50 K - 600/50	S K - Open S - Nema 1 J - Nema 12 R - Nema 3R L - Nema 4 D - Nema 4X Refer to (W) for enclosure availability
TS Transfer Switch	R Power Assisted Non-Automatic SPB-Type	M Mechanically Held			
	D Dual (2) Operating Handles				
	S Single (1) Operating Handle				

Features

- Molded case switch power contact assemblies.
- Positive mechanical interlocking.
- Permanently affixed manual operating handles (MTSSM & MTSDM).
- Pushbutton operation (MTSBM & MTSRM).

Benefits

- High withstand, totally enclosed for maximum arc suppression and isolation during power transfer. Optional trip units offer system overcurrent protection.
- Prevents the paralleling of two sources of power. MTSRM & MTSBM series are also electrically interlocked.
- Permits safe and convenient manual transfer of power.
- Allows transfer of power under load via external pushbutton initiated operation. MTSBM & MTSRM series can easily be upgraded to fully automatic operation.

Standard Withstand, Closing and Interrupting Ratings^{(1) (3)}

Transfer Switch Amp Rating	Rating when used with upstream circuit breaker ⁽⁵⁾			Rating when used with upstream fuse ⁽⁵⁾		
	240V	480V	600V	Max Fuse Rating	Fuse Type (4)	480V
30	100	65	25	200	J,T	200
70	100	65	25	200	J,T	200
100	100	65	25	200	J,T	200
150	100	65	25	400	J,T	200
225	100	65	25	400	J,T	200
300	100	65	25	400	J,T	200
400	65	35	25	600	J,T	200
600	65	50 ⁽²⁾	25	800/1200	J,T	100/200
800	65	50 ⁽²⁾	25	1200/1600	L	100/200
1000	65	50 ⁽²⁾	25	1600	L	200

(1) Tested In Accordance with UL-1008.

(2) 4 Pole units are rated 35KA.

(3) For Maximum breaker rating in circuits where the transfer switch is evaluated as a "motor branch circuit conductor" refer to the NEC Section 430-25 for sizing.

(4) Also can use Class RK5 fuse with 100KA rating.

(5) All ratings are KA.



Transfer Switch Equipment 30 through 4000A

Manual and Non-Automatic Transfer Switches

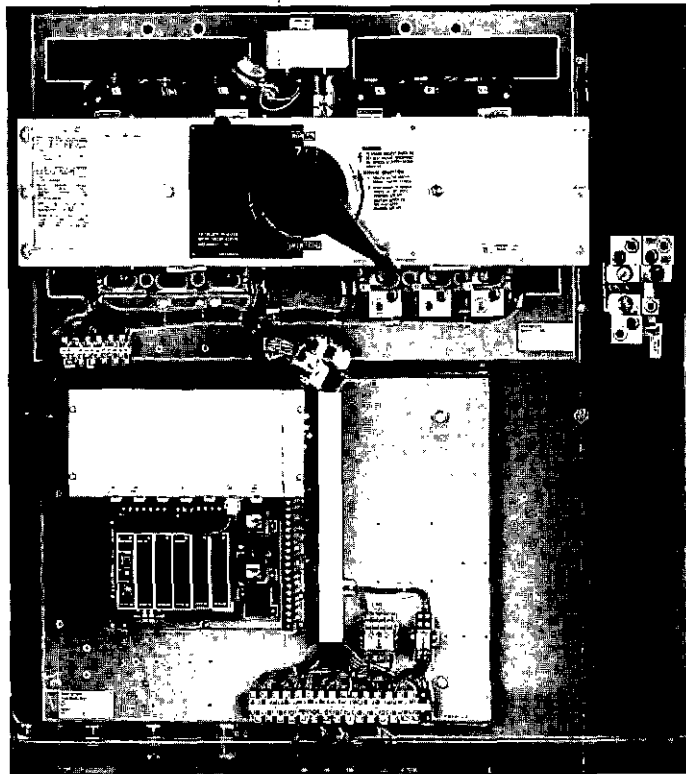

**Non-Automatic Transfer Switch
— Type MTSBM**

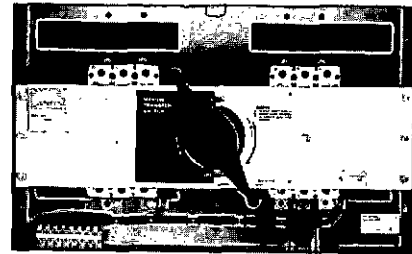

**Single Handle Manual Transfer Switch
— Type MTSSM**

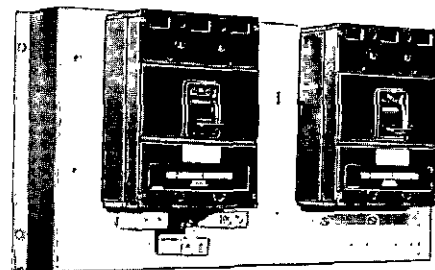

Type MTSDM Dual Operating Handles

Enclosed Units

Open Units

NEMA 1, 3R & 12 Enclosures^② 100-1000 Ampere, 2, 3, 4 Poles

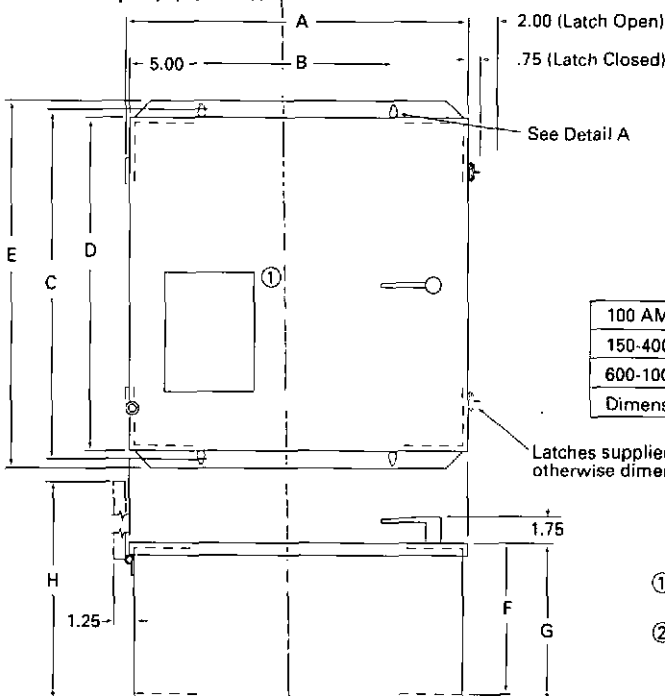

Latches supplied on NEMA 12 & 3R only
otherwise dimensions same as NEMA 1

	A	B	C	D	E	F	G	H
100 AMP	28.88	19.13	39.74	39.62	41.50	9.72	10.22	38.25
150-400 AMP	38.88	29.13	49.74	49.62	51.50	17.28	17.78	55.81
600-1000 AMP	38.88	29.13	59.74	59.62	61.50	17.28	17.78	55.81

Dimensions for MTSRM are same as ATSRM - page - 13

	Approximate Shipping Weight (lbs.)
100 Amps	195
150-300 Amps	425
400 Amps	450
600 Amps	550
800-1000 Amps	625

Note: Add 10% for 4 Pole Units.

① Device panel supplied to house required pilot control devices (lights, selector switches, etc.)

② Call Factory for Dimensions of Type 4 Enclosures

D



Transfer Switch Equipment 30 through 4000A

Transfer Switches - Option 37 Service Entrance Rated 100-4000 Amps

Westinghouse Service Entrance Transfer Switches (Option 37) are the same as other solid state logic design Transfer Switch products with the addition of a service disconnect function accessible externally on the enclosure door. A keyed service disconnect switch permits power assisted load disconnection from either power supply without opening the enclosure. Additionally, the keyed operator can be locked with the load circuits isolated to permit safe downstream maintenance. The Service Entrance Transfer Switch is also equipped with external visual indication of the service disconnect position. Integral overcurrent protection (Options 16) is also included with the Service Entrance Transfer Switch thereby eliminating the need for separate upstream protective devices.

E

Features

- Service disconnect function.
- Integral overcurrent protection.
- Totally integrated design.
- Increased system reliability.
- Solid state logic design.
- Visible indication of service disconnected.
- Lockout in disconnected position.
- Ground fault protection available on all switch ratings - required by code on ratings above 1000 Amps.
- Disconnecting neutral assembly.
- Type B transfer switch.

Benefits

- Lockable disconnect position permits safe downstream maintenance.
- Eliminates the need for separate upstream protective devices.
- **Combined service disconnect, overcurrent protection, and transfer switch functions substantially reduce overall equipment and installation costs and saves space.**
- **Fewer components and power interconnections maximize circuit integrity and minimize maintenance requirements.**
- Same rugged, time-proven design utilized on other Westinghouse solid state logic transfer switch products.

Standard Withstand, Closing and Interrupting Ratings⁽¹⁾

Transfer Switch Amp Rating	Rating when used with upstream circuit breaker			Max Fuse Rating	Fuse Type	Rating when used with upstream fuse
	240V	480V	600V			
30	100	65	25	200	J,T	200
70	100	65	25	200	J,T	200
100	100	65	25	200	J,T	200
150	100	65	25	400	J,T	200
225	100	65	25	400	J,T	200
300	100	65	25	400	J,T ⁽⁴⁾	200
400	65	35	25	600	J,T	200
600	65	50 ⁽²⁾	25	800/1200	J,T	100/200
800	65	50 ⁽²⁾	25	1200/1600	L	100/200
1000	65	50 ⁽²⁾	25	1600	L	200

- (1) Tested In Accordance with UL-1008.
 (2) 4 Pole units are rated 35KA.
 (3) For Maximum breaker rating in circuits where the transfer switch is evaluated as a "motor branch circuit conductor" refer to the NEC Section 430-25 for sizing.
 (4) Also can use Class RK5 fuse with 100KA rating.



Transfer Switch Equipment 30 through 4000A

Service Entrance Transfer Switch (Option 37)

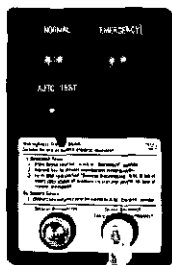
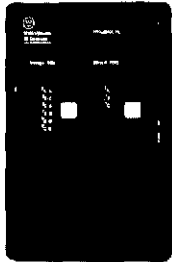

Shown with IQ Generator



Suitable for use as service entrance equipment

To Disconnect Power

- 1 - Place keyed selector switch in "Disconnect" position.
- 2 - Remove key to prevent unauthorized reenergization.
- 3 - Verify pilot light marked "Services Disconnected" is lit. If not lit, verify open status of breakers via flags on breaker faces.

To Restore Service

- 1 - Reinsert key and place selector switch back to "Energize" position.

Services Disconnected



Service Disconnect
Energize Disconnect



Service Disconnect Switch (keyed)

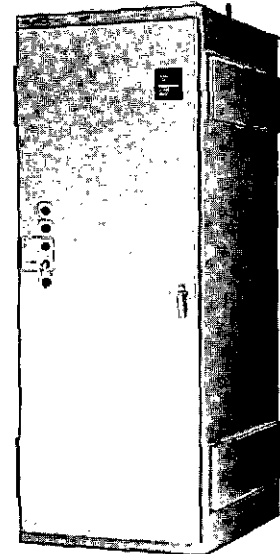

SPB Transfer Switch shown in NEMA 3R enclosure.

E

Dimensions of enclosed units 100-4000 Amps are shown on page 11 (100-1000A) and page 13 (1200-4000A).

Service Entrance Available on the following switches.*

Switch - Type/Construction

- () ATSRD - Drawout/Solid State logic (800-4000A)
- () ATSBM - Automatic/Solid State Logic (100-1000 Amps)
- () ATSRM - SPB Automatic Solid State Logic (1200-4000 Amps)
- () MTSBM - Non-Automatic (Power Assisted Transfer) Solid State Logic (100-1000 Amps)
- () MTSRM - Non-Automatic (Power Assisted Transfer) Solid State Logic (1200-4000 Amps)
- () MTSRD - Drawout (Non-Automatic) (800-4000A)
- () ATSB1 - Bypass Isolator - Solid State logic (100-1000 Amps)

No. of Switched Poles
3

Ampere Rating
0300

Voltage
X

Enclosure
S

- () 2 - 2 Pole
- () 3 - 3 Pole
- () 4 - 4 Pole

- () 0100 - 100 Amp
- () 0150 - 150 Amp
- () 0225 - 225 Amp
- () 0300 - 300 Amp
- () 0400 - 400 Amp
- () 0600 - 600 Amp
- () 0800 - 800 Amp
- () 1000 - 1000 Amp
- () 1200 - 1200 Amp
- () 1600 - 1600 Amp
- () 2000 - 2000 Amp
- () 2500 - 2500 Amp
- () 3000 - 3000 Amp
- () 4000 - 4000 Amp

- () A-120/60
- () B-208/60
- () W-240/60
- () X-480/60
- () E-600/60
- () G-220/50/60
- () M-230/50
- () Z-365/50
- () H-380/50
- () N-401/50
- () O-415/50
- () K-600/50

- () K-Open
- () S-NEMA 1
- () J-NEMA 12

* Equipped with Option 37



Transfer Switch Equipment

30 through 4000A

Westinghouse Combination Bypass Isolation and Automatic Transfer Switches - Type ATSB1 100-1000 Amps

Westinghouse Combination Bypass Isolation and Automatic Transfer Switches are designed for installations where maintenance, inspection, and/or testing must be performed while maintaining continuity of power to the load. This combination switch is typically used in critical life safety/support and extreme emergency power situations that require a higher level of redundancy than the normal standby power application.

Transfer Switch Catalog Number Explanation Switch -Type/Construction

(J)ATSB1-Combination Bypass Isolation and Automatic Transfer Switch

No. of Switched Poles	Ampere Rating	Phase to Phase Voltage	Enclosure
2 - 2 Pole	0100-100 Amp	A - 120/60	S - NEMA 1
3 - 3 Pole	0150-150 Amp	B - 208/60	
4 - 4 Pole	0225-225 Amp	W - 240/60	
	0300-300 Amp	X - 480/60	
	0400-400 Amp	E - 600/60	
	0600-600 Amp	G - 220/50/60	
	0800-800 Amp	M - 230/50	
	1000-1000 Amp	Z - 365/50	
		H - 380/60	
		N - 401/60	
		O - 415/60	
		K - 600/50	

Features

- Superior main contact structure.
- Reliable solid state logic.
- Ease of operation.
- Simple test circuit.
- Designed to safely withstand fault currents.
- Eliminates need for complex interlocks.

Benefits

- Westinghouse requires all power contacts of the Bypass Isolation Transfer Switch to meet UL 1008, UL 1087, and UL 489 standards. This added measure of safety and reliability insures the integrity of the contact assemblies and eliminates the need for periodic maintenance of the contacts, reducing downtime and maintenance costs.
- The Transfer Switch section of the Westinghouse Bypass Isolation Switch utilizes the reliable, time-proven Westinghouse Modular Logic Package. This gives the systems designer the opportunity to tailor the product to his particular application as well as providing the capability of upgrading logic components as needed in the field.
- The Westinghouse Bypass Isolation Switch eliminates all the complicated drawout mechanisms in order to isolate the transfer switch, it utilizes foolproof mechanical Kirk Key interlocking and a positive isolation mechanism. The result is the safest, easiest to operate Bypass Isolation Switch available in the marketplace today.
- When the transfer switch is in the "Isolated" position, complete testing of the automatic transfer switch can be accomplished via a special insulated keyed connector. This allows the operator to completely test the entire operating sequence of the ATS while maintaining power to the connected load. In addition, a portable, hand-held test kit is available to easily test and accurately calibrate the modular solid state logic sensing and timing cards.
- The Westinghouse Bypass Isolation Switch utilizes modified molded case switches, designed specifically for high duty repetitive load transfer, as a means to bypass and isolate the transfer switch. This device provides a reliable, rugged installation that can withstand very high level short circuit.

Bypass Isolation Switch One-Line Diagram

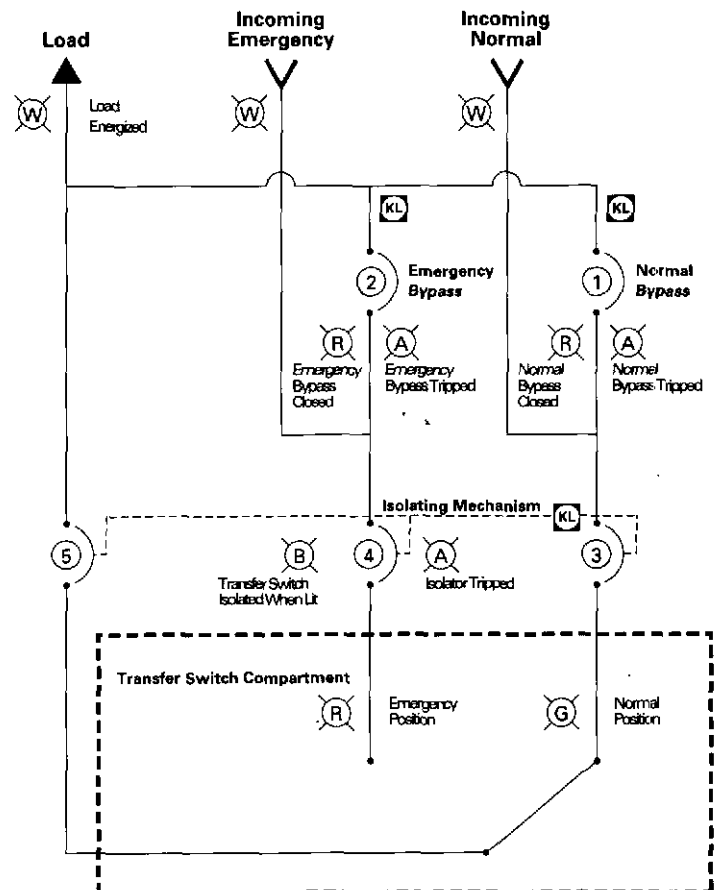



Transfer Switch Equipment 30 through 4000A

Westinghouse Bypass Isolation Switch

"Status" Panel
and Operator Interfaces

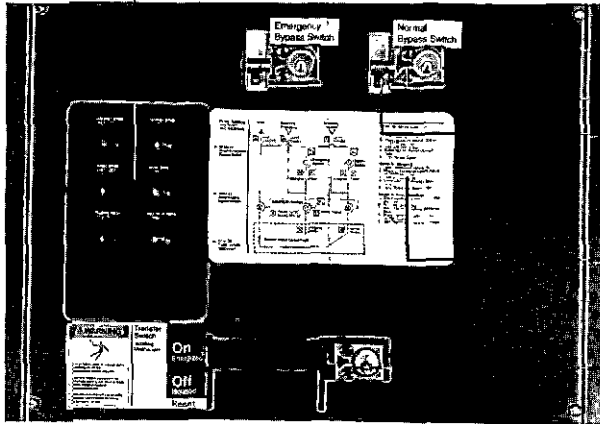

- Rugged Type 1 Enclosure
- Normal Bypass Switch
- Emergency Bypass Switch
- Complete Operational Instructions
- Isolation Switch

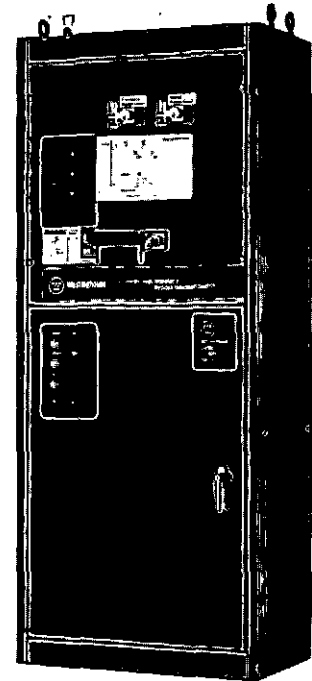

F

100A Bypass Isolation Switch

ENCLOSURE DIMENSIONS 100 AMPS

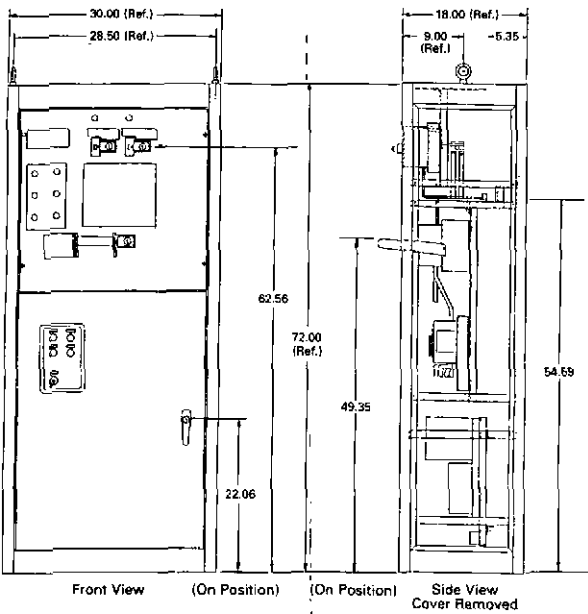

ENCLOSURE DIMENSIONS 150-1000 AMPS

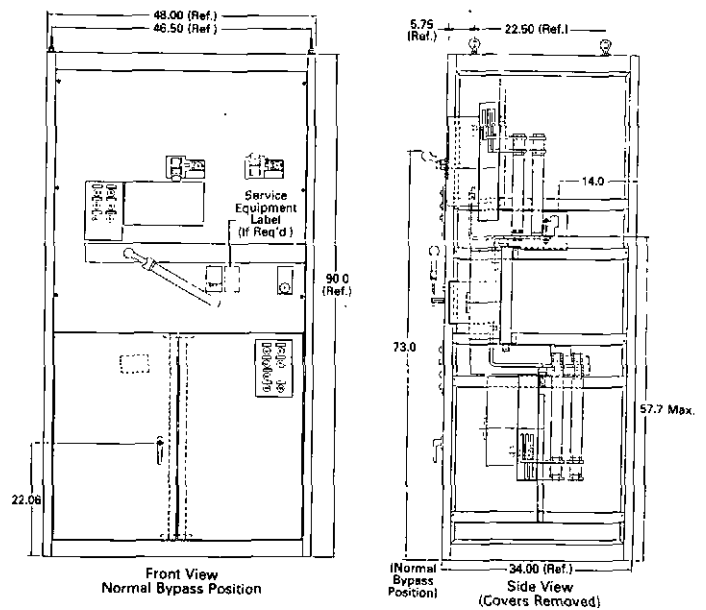

Weights of ATSB

Amps	Lbs.
100	467
300	1078
400	1178
600	1178
800/1000	1358



Transfer Switch Equipment 30 through 4000A

TRANSFER SWITCH FEATURES/ ACCESSORIES

Westinghouse Transfer Switches offer the system designer and user the utmost in flexibility and versatility. All switches include, as standard, the basic features necessary for normal operation. **Westinghouse offers a complete set of options and accessories that allow you to design a switch for a specific application.** Most options can be installed in the field. The Westinghouse line provides a simple and inexpensive means to upgrade or retrofit a transfer switch already installed. NOTE: For features/ accessories not shown below, contact your local Westinghouse Transfer Switch Representative or the factory (800-354-2070) for assistance.

Standard Features/Accessories - The following features are included or standard on all Westinghouse Transfer Switches:

Test Push Button (TPB)- Provides testing of transfer switch operation via the use of a momentary contact push button. Engine starting is initiated by simulation of a Normal Power Source loss and transfer to the Emergency/Standby source will occur.

Full Phase Failure Protection - Provides phase failure protection on each phase of the Normal Power Supply. Should the voltage drop below a pre-selected value on any phase, a signal is sent to start the generator and initiate a load transfer. (For additional voltage and/or frequency sensing requirements for the Normal Power Source, see Optional Accessory 26. For Emergency/Standby sensing, See Optional Accessory 5)

Engine Starting Contacts - Provides a 10A,30VDC contact closure to initiate engine starting upon failure of the Normal Power Source. This feature, specifically designed for low current applications is wired to color-coded, red, terminal blocks on the control panel for ease of identification and maintenance.

Control Circuit Disconnect - Provides plugs to completely isolate the control circuitry for maintenance purposes.

Transfer Motor Disconnect - Provides a plug to disconnect control power to the transfer mechanism to allow testing of the Transfer Switch control logic circuitry without initiating load transfer. (For electrical selector switch transfer motor disconnect, see Optional Accessory 9.)

Transfer Switch Position Indicator - Provides visual contact position indication on the face of the Power Switching Device contact assemblies.

Auxiliary Contacts - Provide indication of switch position for each source via integrally mounted auxiliary switches. 30-1000 Ampere switches include two form C contacts for each Power Source and 1200-4000 Ampere switches include three form C contacts for each Power Source as standard. For additional position indication contacts, consult the factory. (Note: Optional Accessories 12 and 32 may utilize standard auxiliary position contacts as indicated below. Auxiliary Relay Contacts are also available to perform a variety of functions. See Optional Accessory 14.)

Fully Rated Neutral - A fully rated solid neutral is supplied on all two and three pole Westinghouse Automatic transfer switches. All four pole switches are supplied with switched neutral contacts of identical construction and rating as the power poles and are mounted on the power contact shaft integral to the completely enclosed contact assemblies.

Optional Features/Accessories - Listed below are Optional Features/Accessories that will allow you to customize a Westinghouse Automatic Transfer Switch to your particular application. All Features/Accessories are Underwriter's Laboratories, Inc. listed unless noted otherwise. (Note: If a Feature/Accessory is chosen that is not UL listed, the switch will not be supplied with a UL label.)

- 1. Time Delay Normal to Emergency (TDNE)** - Provides a time delay when transferring from the Normal Power Source to the Emergency/Standby Power Source. This Accessory does not affect the engine starting circuit. Timing begins when the source voltage of the emergency/standby power source appears.
 - A. Adjustable 1-60 seconds
 - B. Adjustable .1-10 minutes
 - C. Adjustable .2-30 minutes
- 2. Time Delay Engine Start (TDES)** - This option is for use when the Emergency/ Standby Source is an engine generator. It delays initiation of the engine start circuit in order to override momentary power outages or voltage fluctuations of the normal power source.
 - A. Adjustable .5-15 seconds
 - B. Adjustable 4-120 seconds
- 3. Time Delay Emergency to Normal (TDEN)** - Delays the transfer from the Emergency/Standby Power Source to the Normal Power Source to permit stabilization of the normal power source before retransfer is made. Timing begins when the Normal Power Source appears. If the Emergency/Standby Source fails during timing, transfer to the normal power source is immediate, overriding the time delay.
 - A. Adjustable 1-60 seconds
 - B. Adjustable .1-10 minutes
 - C. Adjustable .2-30 minutes
- 4. Time Delay Engine Cooldown (TDEC)** - Permits the generator to continue to run unloaded after retransfer to normal has occurred. Timing begins when transfer is made.
 - A. Adjustable 1-60 seconds
 - B. Adjustable .1-10 minutes
 - C. Adjustable .2-30 minutes
 - D. Fixed, non-adjustable, five (5) minutes
- 5. Emergency/Standby Source Monitoring** - Provides more precise voltage and/or frequency monitoring of the Emergency/Standby Power Source. Relay prevents transfer from the Normal Power Source to the Emergency/Standby Power Source until that source is within a pre-selected range. In addition, when the switch is in the Emergency/Standby position and that source falls outside the monitor parameters, a load transfer is initiated to the Normal Power Source if it is present.
 - A. Under Frequency Monitor - Provides single phase frequency sensing, adjustable 45-60 HZ (Available on switches utilizing solid state logic sensing only).
 - B. Under Voltage/Frequency Monitor - Provides single phase voltage/frequency sensing. On solid state logic switches, frequency sensing is adjustable 45-60 Hz while voltage sensing is fixed at 90 % of nominal voltage pickup and 70% of nominal voltage dropout. On Electromechanical logic switches, frequency and voltage sensing are fixed at 85% of nominal pickup and 70% of nominal dropout.
 - C. Over Frequency Monitor - Provides single phase frequency sensing adjustable 50- 65 Hz (Available on switches utilizing solid state logic sensing only.)



Transfer Switch Equipment 30 through 4000A

- D. Under Voltage Monitor - Provides adjustable single phase voltage sensing, nominally set at 90% pickup, 70% dropout unless otherwise specified. (Available on switches utilizing solid state logic sensing only.)
- E. Over Voltage Monitor - Provides adjustable single phase voltage sensing, nominally set at 115% dropout, 105% pickup unless otherwise specified. (Available on switches utilizing solid state logic sensing only.)
- F. Under Voltage Monitor - Provides adjustable three phase voltage sensing, nominally set at 90% pickup, 70% dropout unless otherwise specified. (Available on switches utilizing solid state logic sensing only.)
- G. Over Voltage Monitor - Provides adjustable three phase voltage sensing, nominally set at 115% dropout, 105% pickup unless otherwise specified. (Available on switches utilizing solid state logic sensing only.)
- 6. Alternate Test Operators** - While all Westinghouse Automatic Transfer Switches are supplied with a Test Selector Switch as a standard Feature/Accessory, certain applications and/or customer preferences dictate the use of an alternate test operator. When one of the following alternatives is selected, the standard Test Selector Switch is omitted. (Exception: The Standard TSS is not omitted when the override switch, Optional Accessory 6I, is chosen, unless another alternate Test Operator is also selected.)
- D. Test Selector Switch (TSS) - Provides a two-position maintained contact marked "AUTO", "TEST". Test operation of the Automatic Transfer Switch by simulating a loss of the Normal Power Source, causing the engine to start and initiate a load transfer to the Emergency/Standby Power Source.
- F. Three Position Key Operated Test Selector (TPKS) - Provides testing of transfer switch operation via the use of a key operated selector switch. Includes the standard Test Selector Switch features in addition to a "Bypass" feature that overrides the TDEN function this allowing instantaneous retransfer from Emergency Power Source to the Normal Power Source when desired. Key removeable in the "Auto" position.
- G. Two Position Key Operated Test Selector Switch (KOTS) - Identical to the Standard Test Selector Switch except key operated. Key removeable in the "Auto" position.
- H. Four Position Test Selector Switch (FPSS) - Marked "Test", "Auto", "Engine Start", and "Off". Permits four modes of Transfer Switch operation. The "Test" position simulates a failure of the Normal Power Source and functions like the standard Test Selector Switch. The "Auto" position is the regular operational mode. The "Off" position de-energizes the control logic relays and opens the engine start circuit. The switch will not operate nor will the engine start upon failure of the Normal Power Source. A white pilot light is provided to indicate that the FPSS is in the "Off" position. The "Engine Start" position provides testing of the engine start circuit by closing the engine starting contacts and allowing the engine to run unloaded. The switch will not initiate a load transfer with the FPSS in the "Engine Start" position unless there is a failure of the Normal Power Supply.
- I. Fail safe test switch (FTS) - refer to Westinghouse.
- 8. Transfer Time Delay Bypass** - Provides a manual push button operated by-pass on the TDNE (Optional Accessory 1) and/or the TDEN (Optional Accessory 3) function permitting the switch to be transferred to either Power Source without a time delay. This optional accessory is normally used during routine testing of the Emergency/Standby system when it is not desirable to wait for the respective timers to complete their timing sequence before transfer.
- C. Bypass TDEN pushbutton (PBEN)
- D. Bypass TDNE pushbutton (PBNE)
- 9. Maintenance Selector Switch (MSS)** - Marked "OFF", "ON". Provides selector switch disconnection of control power to the Transfer Motor circuit thus allowing testing of the Transfer Switch Control logic circuitry without initiating load transfer. (Manual disconnection is standard on all Westinghouse Automatic Transfer Switches.) Positioning the MSS in the "Off" position isolates the control logic circuit from the Transfer Motor, permitting manual operation of the Transfer Switch or testing of logic circuitry without load transfer.
- B. Maintained Contact MSS
- D. Key Operated MSS. Key Removeable in the "On" position.
- 10. Preferred Source Selector Switch (PSSS)** - Permits the selection of either source as the "Preferred" source to which the automatic transfer switch will always seek if that source is available. Marked "SOURCE 1", "SOURCE 2".
- B. PSSS for use on systems comprised of Dual Utility or Utility/Engine Generator power sources.
- D. PSSS for use on systems comprised of Dual Engine Generator power sources. (Dual Engine starting circuits are provided when option/accessory 10D is selected.)
- 12. Indicating Lights**
- Switch Position**
- C. Green Pilot Light (NL) indicates that the load is connected to the Normal Power Source. Marked "NORMAL". Switch utilizes 1A Power Switching Device auxiliary contact from the respective power sources.
- D. Red Pilot Light (EL) indicates that the load is connected to the Emergency/Standby Power Source. Marked "EMERGENCY". Switch utilizes 1A Power Switching Device auxiliary contact from the respective power sources.
- Source Availability**
- G. White Pilot Light (SN) indicates voltage is present on the line side of the Normal Power Source. Marked "NORMAL SOURCE".
- H. White Pilot Light (SE) indicates voltage is present on the line side of the Emergency/Standby Power Source. Marked "EMERGENCY SOURCE".
- Tripped Condition** (Available only when integral overcurrent protection selected - Option 16)
- L. Amber Pilot Light (TN) indicates overcurrent trip condition on normal side main contacts.
- M. Amber Pilot Light (TE) indicates overcurrent trip condition on emergency side main contacts.
- 14. Relay Auxiliary Contacts** - Three Form C contacts are provided on all Automatic Transfer Switches utilizing solid state logic sensing and two Form C contacts are provided on those utilizing Relay Logic sensing.
- C. Normal Source Relay Auxiliary Contacts (NRA) - Energized when the load is connected to the Normal Power Source Power Supply and Normal voltage is present.
- D. Emergency/Standby Source Relay Auxiliary Contacts (ERA) - Energized whenever Emergency/Standby Source voltage is present.



Transfer Switch Equipment 30 through 4000A

16. Integral Overcurrent Protection - Provides overcurrent protection integral to the Power Switching Device(s). Use of the option/ accessory can, in many cases, eliminate the need for separate upstream, overcurrent/short circuit protection and provide significant material, labor, and space savings over other system layouts. In addition to overcurrent protection, for safety purposes, selection of this optional accessory also includes a lock-out function that prevents further automatic transfer operation until the appropriate source is manually reset. (Note: Four pole transfer switches include overcurrent protection only on the three power poles.) Units rated 1200 amps and greater will also be supplied with an amber indicating light marked "Tripped Condition" indicating an overcurrent trip status. (See Options 12 L and M for trip lights on units 1000 amps and below.) For detailed information regarding integral overcurrent protection, contact the factory.

Transfer Switches Rated 30-1000 Amperes

Thermal Magnetic Overcurrent Protection

- A. Overcurrent Protection on Both Power Sources.
- E. Overcurrent Protection on the Emergency/Standby Power Source only.
- F. Overcurrent Protection on the Normal Power Source Supply only.

Transfer Switches Rated 1200-4000 Amperes

Digitrip RMS Microprocessor Overcurrent Protection

Digitrip RMS provides true RMS sensing in lieu of conventional bimetal trip elements allowing the ultimate in selectivity and system coordination, and can be supplied with integral ground fault protection, energy monitoring, and/or remote communication capabilities. Contact the factory for further information on this Westinghouse Transfer Switch exclusive feature.

The specifier and/or user has a choice of several protection function combinations as shown in Table 16-2 below. Please specify the particular combination required for system coordination. (Note: If a combination is not specified, the Digitrip RMS will be provided with Long Time/Instantaneous Protection.)

Table 16-2

Protection Function	Designation	
	W/O GFP	W/GFP
Long Time/Instantaneous	LI	LIG
Long Time/Short Time	LS	LSG
Long Time/Short Time/Instantaneous	LSI	LISG

- R. Digitrip RMS on both power sources (specify designation from Table 16-2 i.e. 16R w/LI.)
- S. Digitrip RMS on Emergency/Standby Power Source only (specify designation from Table 16-2 i.e. 16S w/LS.)
- T. Digitrip RMS on Normal Power Source only (Specify designation from Table 16-2 i.e. 16T w/LSIG.)

Table 16-1

(Contact the factory for application requiring trip ratings other than those listed below.)

SWITCH RATINGS	NO. OF SWITCHED POLES	TRIP RATINGS
30	2,3,4	15,20,25,& 30
70	2,3,4	15,20,25,30,35,40,45,50,60 & 70
100	2,3,4	15,20,25,30,35,40,45,50,60,70,80,90,& 100
150	2,3,4	100,125,& 150
225	2,3,4	100,125,150,175,200, & 225
300	2,3,4	100,125,150,175,200,225,250 & 300
400	2,3,4	250,300,350, & 400
600	2,3	150,175,200,225,250,300,350,400,500, &600
600	4	600
800	2,3,4	600,700 & 800
1000	2,3,4	600,700,800,900, & 1000
1200	2,3,4	600,800,1000 & 1200
1600	2,3,4	800,1000,1200, & 1600
2000	2,3,4	1000,1200,1600, & 2000
2500	2,3,4	1600,2000 & 2500
3000	2,3,4	1600,2000,2500 &3000
4000	2,3	2000,2500,3000,3200, &4000

Note: 1. Trip rating should be specified when ordered. If no rating is specified, the Transfer Switch will include trip units rated the same as the switch rating.)

2. Transfer switches supplied with integral overcurrent protection comply with IEC 947-1 and NEMA ICS 2-447 requirements for Type B Transfer Switches equipped with integral overcurrent protection.





Transfer Switch Equipment 30 through 4000A

18. Metering and Communications

• Analog Meters

- E. Analog Voltmeter - Includes PT's and seven position selector switch allowing voltage reading of the line side of all phases of both power sources. (2% accuracy)
- F. Analog Ammeter - Includes CT's and four position selector switch allowing current reading of each phase of the connector load. (2% accuracy)
- G. Analog Frequency Meter - Includes transducer allowing frequency reading of the line side of the Emergency/Standby Power Source. (.5% accuracy)
- H. Analog Running Time Meter - Indicates the total amount of time that voltage is present on the line side of the Emergency/ Standby Power Source.

Westinghouse IQ Meters

The Westinghouse IQ Family of Microprocessor based digital meters offers the latest technological advances in metering and communications functions for today's complex system designs. Line side voltage is monitored phase-to-phase and phase-to neutral with 1% accuracy, and current is monitored from each phase of the connected load with 1% accuracy. Frequency is monitored from the line side of the source with .5% accuracy. The entire IQ Family is also available with remote monitoring and communications capabilities via the Westinghouse IMPACC System. Consult the factory for applications requiring remote monitoring/communications.

- **IQ Generator** - The IQ Generator is a microprocessor based monitoring device that provides simultaneous current, voltage and frequency metering. In one compact standard package, the IQ Generator provides an alternative to individually mounted and wired ammeters, voltmeters, ammeter and voltmeter switches, and frequency meters. The IQ Generator provides 1% accuracy on voltmeter and ammeter function and .5% on frequency. Includes CT's, PT's and power module required for operation and can be supplied on the Normal Power Source, The Emergency/ Standby Power Source, or with a selector switch allowing reading for both power sources (please specify).

- I. Normal
- J. Emergency
- K. Both N and E

- **IQ Data Plus II** - The IQ Data Plus II is a microprocessor based monitoring device that provides complete electrical metering and energy monitoring. In one compact, standard package, the IQ Data Plus II provides an alternative to individually mounted and wired ammeters, voltmeter, ammeter, ammeter and voltmeter switches, wattmeter, watthour meters, and more. This device provides 1% accuracy on voltmeter and ammeter functions, .5% accuracy on frequency, 2% accuracy on watts, watt demand, watt hours, and vars, and 4% accuracy on power factor readings. It will also provide indication of phase loss, phase unbalance, phase reversal, over voltage and under voltage. The IQ Data Plus II includes the CT's, PT's and power module required for operation and can be supplied on the normal or emergency/ standby power (please specify).

- L. Normal
- M. Emergency
- N. Both N and E

- P. **IMPACC Communications** - Refer to factory for applications requiring remote monitoring and/or communications capabilities.

- 20. **Rear Bus Provisions** Standard 30-1000 Ampere Westinghouse Transfer Switches are assembled with front connected solderless lugs. Standard 1200-4000 Ampere Switches are assembled with rear connected solderless lugs.

- A. Rear Bus Provisions- Provide separate bus stabs extending to the rear from the line side of the Normal and Emergency/ Standby Power Switching Devices as well as common load stabs, allowing the installer to connect his bus to the transfer switch. Available only on open switches from 150-1000 Amperes, and on open or enclosed 1200-4000 Ampere switches. (Not available on 30-100 Ampere switches)

21. Optional Terminals

- A. Refer to Wire Terminal Data, Page 32 to make the appropriate selection for your applications.

23. Plant Exerciser (PE)

Solid state, digital clock timer with long-life lithium battery backup provides means for automatic testing of the Emergency/Standby Power Plant. This device is programmable to allow a maximum of 10 programs of automatic testing per week. Run time is fully adjustable with set points from 1 second to 168 hours.

- C. Engine Start/Run Only - Starts Emergency/Standby Power Plant and runs engine without load transfer. However, if the Normal Power Supply fails during the exercise period, load transfer will occur.
- D. Exercise With Load Transfer - starts Emergency/Standby Power Plant and initiates load transfer. Automatically transfers back to the Normal Power Source at the end of the Exercise period.
- G. Exercise With or Without Load Transfer- Programmable to allow selection of Engine Start/Run only, Exercise with Load Transfer, or a complete bypass of the Exercise system. Includes selector switch marked "Engine Run", "Bypass", "Load Transfer".
- I. Exercise with Load Transfer and Failsafe Feature - Similar to Optional Accessory 23D except with Failsafe Feature. This feature provides an immediate transfer to the Normal Power Source if Emergency/Standby Power Source fails during exercising period. (Available only on Transfer Switches utilizing solid state logic sensing.)
- J. Exercise with or without Load Transfer and Failsafe Feature - Similar to Optional Accessory 23G except with Failsafe Feature. If the Emergency/Standby Power Source should fail while Exercising in the "Load Transfer" mode, and immediate retransfer to the Normal Power Supply will occur. (Available only on transfer switches utilizing solid state logic sensing.)

24. Battery Charger (BC)

Fully automatic 5 Ampere float battery charger for engine cranking batteries. Uses ferroresonant transformer technology which is self-regulating and completely devoid of any complicated switching circuits. The charger comes in its own #304 stainless steel housing for separate mounting and includes a DC Ammeter allowing instant visual identification of charger output status. Unit requires a separate 100-135 VAC/60 Hz power supply for hookup. (Contact the factory for applications requiring a 220VAC/50Hz power supply.)

- C. Battery Charger with 12 VDC output
- D. Battery Charger with 24 VDC output
- E. Battery Charger with 32 VDC output.

26. Type of Protection (Normal Source) ⁽¹⁾⁽⁴⁾

Full phase protection is standard. A voltage sensing relay monitors each phase of the normal power supply. Normally set at 70% dropout and 90% pickup.





Transfer Switch Equipment 30 through 4000A

- C. *Overvoltage sensing relay - Adjustable. Nominally set at 115% dropout, pickup below 105%.*
- D. *Area Protection Connections With Override Circuit - Provides two terminal blocks for connection of one or more NO (open when there is no voltage) area protection contacts; these terminal blocks are wired in the same manner as the test switch and when the NO area protection contact opens, the switch initiates engine start and will transfer to Emergency Power Source. In the event that the NO area protection contact remains open and the Emergency Source fails when the switch is in the Emergency position, an override circuit will retransfer the switch to the Normal Source if it is available.*
- E. *Under frequency, adjustable 45-60 Hz (Drops out 2 Hz lower than setting). A frequency sensing relay is connected to 1 phase only of the Normal Source, constantly monitoring that phase.*
- F. *Over frequency, adjustable 50-65 Hz (Drops out 2 Hz above setting). A frequency sensing relay is connected to 1 phase only of the Normal Source, constantly monitoring that phase.*

28. Intelligence Circuit Fuses ⁽¹⁾

- A. Provides fuses on all non-essential control circuitry.

29. Type of Operation ⁽¹⁾

Automatic operation is standard. Provides for automatic transfer and retransfer from source to source as dictated by the reset values of the transfer switch intelligence circuits.

- E. *Pushbutton return to normal. Automatic operation Normal to Emergency. Pushbutton operation Emergency to Normal. Includes failsafe feature providing immediate retransfer to Normal if Emergency fails while in that position.*
- G. *Automatic/Manual Operation. Two position selector switch (marked Auto/Manual) permits selection of Automatic or Manual operation. Includes pushbuttons for manual operation when selector switch is in the manual position.*
- J. *Automatic/Pushbutton Operation Return to Normal. Two position selector (marked Auto/Manual) permits selection of automatic or pushbutton operation Emergency to Normal, automatic Normal to Emergency. Includes option 29E which only operates to return to Normal when the switch is in the manual mode.*

30. Cranking Limiter ^{(1) (2)}

- A. Adjustable 0-120 seconds. Interrupts engine start circuit if voltage does not appear within preselected time.

32. Delayed Transition Timer

- A. Provides a time delay in the Neutral (Off) position when the load is transferred in either direction to prevent excessive inrush currents due to out-of-phase switching of large inductive loads. Utilizes one normally open breaker contact.

33. Shunt Trip

Wired to terminal blocks for customer connection. Specify coil voltage desired (120VAC standard).

- A. Supplied in normal breaker
- B. Supplied in emergency breaker

34. Extender Cable ⁽¹⁾

Permits remote mounting of intelligence circuitry to accommodate limited space applications.

- A. 48 inches
- B. 72 inches
- C. 96 inches
- D. 120 inches
- E. 144 inches

(Special lengths available. Contact Westinghouse).

35. Pre-Transfer Signal Device ⁽¹⁾

Contacts open/close on a timed basis (adjustable 0-120 seconds) to allow the load to be de-energized prior to transfer in either direction. (Typically used in conjunction with elevator controls).

- A. Form C contacts (2NO, 2NC)

37. Service Entrance Rated Transfer Switches (See Page 18 for detailed information.)

- A. SE. Rated w/o GFP
- B. SE. Rated w/ GFP

38. Hand Held Test Kit

Self-contained test kit used for calibration and testing of printed circuit cards and output relays used in the solid state logic units. Works on standard 120 VAC wall outlet.

39. Freestanding Enclosure 100-1000 Ampere Transfer Switch

40. Remote Load Shed/Add Capability

Refer to Westinghouse for specific application

41. Space Heater with Thermostat

- A. 100W
- B. 200W
- C. 400W

- (1) Available only on Automatic Switches
- (2) Not UL listed
- (3) Timing ranges are recommended ranges only. Actual time setting can be adjusted from 0 seconds to 10 hours. All timers are factory set at 0 seconds.
- (4) A maximum of two Normal Source sensing options from Options 26C, 26E, and 26F may be chosen at the same time.
- (5) Supplied unmounted if Option 22 is selected.
- (6) Available on Automatic, Basic and Manual Switches

Other Engineered Accessories

Due to the flexibility of the Westinghouse Transfer Switch design and our unique customer driven manufacturing facility, we can modify our products to meet many user requirements. Some of the most common engineer modifications are listed below, but if your installation requires something different, give us a call at 1-800-354-2070. Our experienced design engineers are well equipped to solve your most challenging application problems and provide greater value to your transfer switch equipment.

Load Sequencing

It is often desirable to buffer the full load impact accompanying power transfer to a standby generator source. The Westinghouse ATS can be equipped with timed sequence restart contracts which permits step loading of the engine generator and avoids the potential for overburdening your only remaining source of power.



Transfer Switch Equipment 30 through 4000A

Load Shedding

Our Option 40 covers a wide range of load shedding capabilities available with the Westinghouse ATS; some are industry exclusives.

- Local Load Shedding

Our transfer switch products can be modified to permit independent power contact operation enabling total disconnection of load circuits when required.

A very practical example of the importance to this local load shed feature is the aviate to protect highly sensitive loads. Should a single phase condition occur on the normal power source feeding a polyphase motor downstream of the transfer switch, immediate disconnection of this load must occur to prevent motor damage. A Westinghouse ATS equipped with a load shed feature would not only sense this condition and start the standby generator, but would also disconnect the load from the failing normal source until a stable standby power supply could safely assume the load. This feature could be added to the ATS at a fraction of the cost and complexity of separate motor protection logic.

- Remote Load Shedding

The Westinghouse ATS can be provided with load shed contact which interface with other downstream load circuits to selectively disconnect such loads.

Examples include: Disconnecting non-critical loads prior to transfer to a reduced capacity standby power source, disconnection of selected loads as current usage exceeds certain levels, alternately disconnecting or reconnecting similar loads such as pump motors on timed sequential basis.

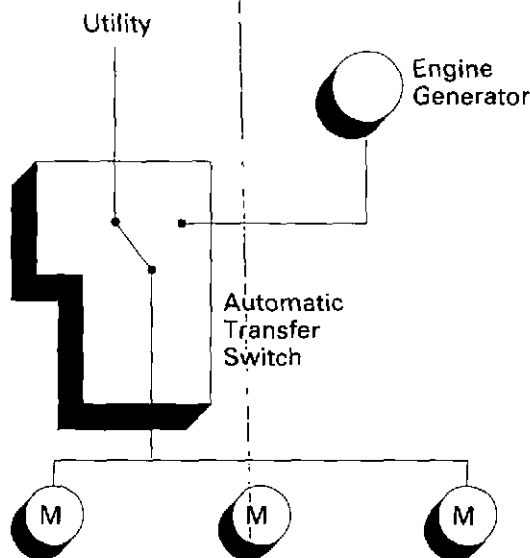

- Alternate Switching Between Dual Generator Sources

On page 5, figure 3 of this bulletin, a dual generator is illustrated. In certain remote areas where commercial power is either not accessible or unreliable and in installations where on-site power generation is economically desirable, dual generators may be employed for both prime and standby power.

The Westinghouse ATS can be equipped with timing logic to periodically switch between such sources of power to permit maintenance of such generating equipment.

- Three Power Source Standby Systems

On page 5, figure 5, of this bulletin, a 3 source standby system is illustrated. Westinghouse can provide a completely integrated product to meet the added considerations that such a system may entail.

- Peak Shaving

Whether we supply the logic or receive signals from other equipment, the Westinghouse ATS can automatically transfer load circuits to standby power to avoid peak demand charges.

- Mounting Modifications

Westinghouse Transfer Switches can be arranged to provide a narrower, more compact design for mounting in other equipment such as motor control centers.

- Alternate Power Sensing

Some of our customers want to make transfer decisions based on criteria other than conventional voltage/frequency monitoring. We can provide alternate power sensing functions such as: Phase sequence/reversal, current, power factor, phase unbalance, ground fault, and power circuit conditions as required.

- Surge Suppressors

Lightning surge suppressors are at times needed in order to minimize problems associated with lightning strikes.

Whatever your standby power installation requirements may be, the Westinghouse Engineering Support Team can work with you to create a superior engineered transfer switch products to satisfy the most demanding application parameters.

IQ-IMPACC FAMILY

Integrated Monitoring Protection and Control Communications System.

IQ Generator (TM) - Digital Metering Device

The IQ Generator is a microprocessor based monitoring device that provides simultaneous current, voltage and frequency metering. In one compact, standard package, the IQ Generator provides an alternative to individually mounted and wired ammeters, voltmeters, ammeter and voltmeter switches, and frequency meters.





Transfer Switch Equipment 30 through 4000A

Direct Reading Metered Values

<u>AC Ampere</u>		1% accuracy
Phase A		
Phase B		
Phase C		
<u>AC Voltage</u>		1% accuracy
Phase A-B	Phase A - Neutral	
Phase B-C	Phase B - Neutral	
Phase C-A	Phase C - Neutral	
Frequency		0.5% accuracy

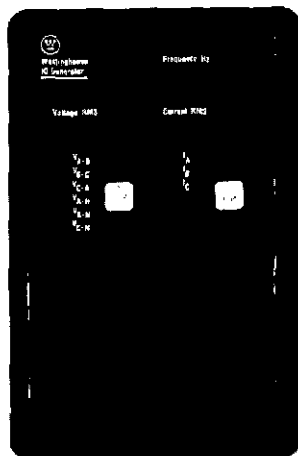

Customer Benefits

- Space savings replaces Ammeter, Voltmeter, Selector Switches and Frequency Meter.
- Standardization of design. One door mounted device
- Three, 4-digit display windows for simultaneous viewing of current, voltage and frequency.
- Separate step buttons for current and voltage.
- Optional communications port for two wire connection to Westinghouse IMPACC network.

Additional Features

- Simple electrical connections
- 50/60 cycle
- Door mounted (2.5 inches depth)
- Membrane faceplate, designed and tested to perform in a harsh industrial environment (NEMA 3R,12)
- Retains preset parameter through power failure with use of field settable DIP switches (no batteries).
- UL recognized
- CSA certified
- ANSI 37.90
- Unit will be powered from the line it is monitoring.
- Frequency 50/60 Hz
- Line characteristics Nominal Line +20% will continue to operate in the event of phase loss.

IQ Data Plus II

The IQ Data Plus II is a microprocessor based monitoring and protective device that provides complete electrical metering and system voltage protection. In one compact, standard package, the Data Plus II provides an alternative to individually mounted and wired ammeters, voltmeters, ammeter and voltmeter switches, wattmeters, watt-hour meters, and more.

Direct Reading Metered Values

<u>AC Ampere</u>		1% Accuracy
Phase A		
Phase B		
Phase C		
<u>AC Voltage</u>		1% Accuracy
Phase A-B	Phase A - Neutral	
Phase B-C	Phase B - Neutral	
Phase C-A	Phase C - Neutral	
Watts		2% Accuracy
Vars		2% Accuracy
Power Factor		4% Accuracy
Frequency		0.5% Accuracy
Watt Demand		2% Accuracy
Watt Hours		2% Accuracy

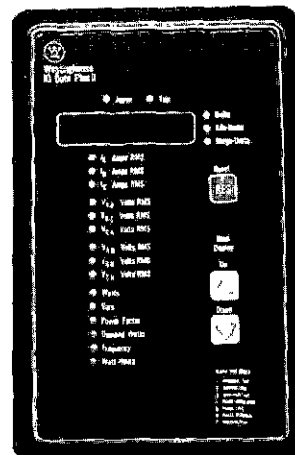

Additional Features of IQ Data Plus II

- Pulse initiation on watt-hour pulse as programmed by the user at certain KWH or MWH rates.
- A sync pulse contact for the demand window provides for synchronizing time with the utility (rated 24VDC.)
- Auto ranging of units (units, kilounits, megaunits.)
- Alternate power factor calculation (for unbalanced and non-sinusoidal waveforms.)
- Simple electrical connections (same as wattmeter).
- 50/60 cycle.
- 3 wire or 4 wire systems.
- Door mounted (4.5 inches in depth.)
- Selfprotected from fault.
- Updated data every 1.5 seconds.
- Optional communication port for two-wire connection to Westinghouse INCOM network.
- Frequency 50/60 Hz.

G



Transfer Switch Equipment 30 through 4000A

Line Characteristics

- Nominal Line +20%
- Will continue to operate in the event of a phase loss

Customer Benefits

- Space savings in structure. Replaces Ammeter, Voltmeter, Selector Switches, Wattmeter, etc.
- Standardization of design. One door mounted device.
- Interface capability to computer network for data collection, storage and/or printout via IMPACC, the Westinghouse two-wire local area network.
- Membrane faceplate designed and tested to perform in harsh industrial environment (NEMA 3R, 12).
- Retains preset parameters through power failure with use of field settable DIP switches (no batteries).
- Non-volatile memory for storage of readings at time of trip.
- Separate Alarm and Trip relay outputs.
- UL recognized
- CSA certified
- ANSI C37.90

Field Settable Protection Functions with Trip and/or Alarm Outputs

- Phase Loss (Voltage or Current)
- Phase Unbalance (Voltage)
- Phase Reversal (Voltage)
- Overvoltage
- Undervoltage
- Unit will be powered from the line it is monitoring.

Communications Software Packages

Series I: This software is provided with a computer operated network interface expansion card. It provides the capability for on-site communications via IMPACC to a computer or can be used to connect IMPACC via a telephone modem and a MINT unit to a remote computer. Series I performs the following functions: Time/event data logging, device alarm/trip status logging data storage and retrieval, hardware diagnostics and a remote ON/OFF control.

Series II: Provides a customer with the opportunity to tailor their own IMPACC System Software program. It utilizes a Master INCOM Network Translator (MINT) to translate between IMPACC and RS-232. Along with the MINT customers receive a INCOM Protocol Manual that describes the structure of RS-232 messages, how to issue commands and how to receive data.

Series III: This is a menu driven complete software package that permits easy set up and operation. In addition to all the features of Series I it also provides: Operation in the Microsoft Windows™ environment, Security Access, Analog Alarming, Enhanced Graphics and a Gateway Interface to another computer or SCADA System via RS-232.

Communications

From a central location, an operator utilizes a computer to monitor, control and communicate with transfer switches and other electrical equipment. As many as 1000 devices can be on the system and communications lines can be extended up to 7500 feet from the PC without using repeaters.

Series III Communications and Control

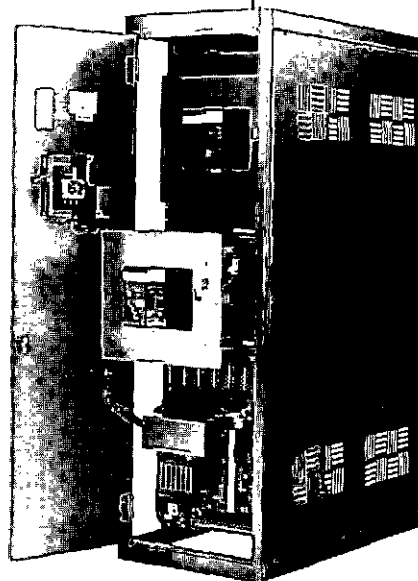

G

Controls	Communications	Monitors
Test Load	Switch Position	System Parameters
No Load	Source Availability	Voltage
Transfer T.D.	Load Energized	Current
Bypass	System Parameters	Frequency
		PF, etc.
		Mode of Transfer



Transfer Switch Equipment 30 through 4000A

Ordering Information

1. Order by description and catalog number
 - A. Type of System
 - 1 Phase, 2 Wire: Use 2 pole switch plus solid neutral
 - 3 Phase, 3 Wire: Use 3 pole switch
 - 3 Phase, 4 Wire: Use 3 pole switch plus solid neutrals or 4 pole switch.
- For other applications, refer to Westinghouse.
4. Ordering example: Automatic Transfer Switch, Catalog Number ATSBM30225XK, 480 volts, 60Hz, 3 phase, 4 wire, 225 ampere, with Options 1A, 2A, 3C and 9B.

List Prices: Refer to Price List 29-920.

Enclosures, Description

- NEMA 1: Intended for indoor use to protect against a limited amount of falling dirt.
- NEMA 12: Intended for indoor use to protect against dust, falling dirt, and dripping non-corrosive liquids.
- NEMA 3R: Intended for outdoor use to protect against falling rain and sleet.
- NEMA 4: Intended for indoor or outdoor use to protect against splashing water and windblown rain.
- NEMA 4X: Intended for indoor or outdoor use to protect against splashing water and windblown rain. Resists corrosion.

30-1000 Amps	1200-4000 Amps
K-Open	K-Open
S-NEMA 1	S-NEMA 1
J-NEMA 12	R-NEMA 3R
R-NEMA 3R	
L-NEMA 4	
D-NEMA 4X	

H Transfer Switch Catalog Explanation

Switch Type/Construction	NO. OF SWITCHED POLES	AMPERE RATING	VOLTAGE	ENCLOSURE
	3	0600	X	S
<input type="checkbox"/> ATSBM — AUTOMATIC/SOLID STATE LOGIC (100-1000 AMPS)	<input type="checkbox"/> 2 - 2 POLE	<input type="checkbox"/> 0030-30 AMP	<input type="checkbox"/> A - 120/60	<input type="checkbox"/> K - OPEN
<input type="checkbox"/> ATSRM — SPB AUTOMATIC/SOLID STATE LOGIC (1200-4000 AMPS)	<input type="checkbox"/> 3 - 3 POLE	<input type="checkbox"/> 0070-70 AMP	<input type="checkbox"/> B - 208/60	<input type="checkbox"/> S - NEMA 1
<input type="checkbox"/> ATSBP — AUTOMATIC/RELAY LOGIC (30-1000 AMPS/60 HZ ONLY)	<input type="checkbox"/> 4 - 4 POLE	<input type="checkbox"/> 0100-100 AMP	<input type="checkbox"/> W - 240/60	<input type="checkbox"/> J - NEMA 12
<input type="checkbox"/> MTSSM — MANUAL/SINGLE HANDLE OPERATION (100-1000 AMPS)		<input type="checkbox"/> 0150-150 AMP	<input type="checkbox"/> X - 480/60	<input type="checkbox"/> R - NEMA 3R
<input type="checkbox"/> MTSDM — MANUAL/DUAL HANDLE OPERATION (100-1000 AMPS)		<input type="checkbox"/> 0225-225 AMP	<input type="checkbox"/> E - 600/60	<input type="checkbox"/> L - NEMA 4
<input type="checkbox"/> MTSBM — NON-AUTOMATIC/TRANSFER MANUALLY INITIATED, ELECTRICALLY OPERATED (100-1000 AMPS)		<input type="checkbox"/> 0300-300 AMP	<input type="checkbox"/> G - 220/50/60	<input type="checkbox"/> D - NEMA 4X
<input type="checkbox"/> MTSRM — SPB NON-AUTOMATIC, ELECTICALLY OPERATED (1200-4000 AMPS)		<input type="checkbox"/> 0400-400 AMP	<input type="checkbox"/> M - 230/50	
<input type="checkbox"/> BTSBM — BASIC/POWER PANEL ONLY — NO LOGIC (100-1000A)		<input type="checkbox"/> 0600-600 AMP	<input type="checkbox"/> Z - 365/50	
<input type="checkbox"/> BTSRM — BASIC/POWER PANEL ONLY — (1200-4000A)		<input type="checkbox"/> 0800-800 AMP	<input type="checkbox"/> H - 380/50	
<input type="checkbox"/> ATSB1 — BYPASS ISOLATION TRANSFER SWITCH (100-1000 AMPS)		<input type="checkbox"/> 1000-1000 AMP	<input type="checkbox"/> N - 401/50	
<input type="checkbox"/> ATSRD — DRAWOUT TRANSFER SWITCH (800-4000A)		<input type="checkbox"/> 1200-1200 AMP	<input type="checkbox"/> O - 415/50	
<input type="checkbox"/> MTSRD — DRAWOUT NON-AUTOMATIC (800-4000A)		<input type="checkbox"/> 1600-1600 AMP	<input type="checkbox"/> K - 600/50	
		<input type="checkbox"/> 2000-2000 AMP		
		<input type="checkbox"/> 2500-2500 AMP		
		<input type="checkbox"/> 3000-3000 AMP		
		<input type="checkbox"/> 4000-4000 AMP		

To be used only for catalog number interpretation — cannot be used to build a catalog number.



Transfer Switch Equipment
30 through 4000A

Wire Size Data For External Power Cable Connections

Switch Cables Rating (Amps)	Per Phase	Range of Wiring Sizes	Standard	Alternate (Opt. 21A)	Type of Conductor
<input type="checkbox"/> 30-100	1	#4-1/0	X	N/A	CU/AL
<input type="checkbox"/> 150-300	1	#3-350MCM	X		CU/AL
<input type="checkbox"/> 150-300	1	#3-350MCM		X	CU
<input type="checkbox"/> 150-300	2	#3-350MCM		X	CU/AL
<input type="checkbox"/> 400	2	250-500MCM	X	X	CU
<input type="checkbox"/> 600	2	#1-500MCM	X		CU/AL
<input type="checkbox"/> 600	3	3/0-400MCM		X	CU/AL
<input type="checkbox"/> 600	2	500-750MCM		X	CU/AL
<input type="checkbox"/> 600	1	#1-600MCM		X	CU
<input type="checkbox"/> 600	2	2/0-500MCM		X	CU
<input type="checkbox"/> 800	3	3/0-400MCM	X		CU/AL
<input type="checkbox"/> 800	4	4/0-500MCM		X	CU/AL
<input type="checkbox"/> 1000	4	4/0-500MCM	X		CU/AL
<input type="checkbox"/> 800-1000	3	500-700MCM		X	CU/AL
<input type="checkbox"/> 800-1000	4	3/0-400MCM		X	CU
<input type="checkbox"/> 1200	4	4/0-500MCM	X		CU/AL
<input type="checkbox"/> 1200	3	3/0-400MCM		X	CU/AL
<input type="checkbox"/> 1200	3	500-750MCM		X	CU/AL
<input type="checkbox"/> 1200	3	3/0-500MCM		X	CU
<input type="checkbox"/> 1200	4	3/0-400MCM		X	CU
<input type="checkbox"/> 1600-2000	8	4/0-500MCM	X		CU/AL
<input type="checkbox"/> 1600-2000	6	3/0-400MCM		X	CU/AL
<input type="checkbox"/> 1600-2000	6	500-750MCM		X	CU/AL
<input type="checkbox"/> 1600-2000	6	2/0-500MCM		X	CU
<input type="checkbox"/> 1600-2000	8	3/0-400MCM		X	CU
<input type="checkbox"/> 2500-3000	12	4/0-500MCM	X		CU/AL
<input type="checkbox"/> 2500-3000	9	3/0-400MCM		X	CU/AL
<input type="checkbox"/> 2500-3000	9	500-750MCM		X	CU/AL
<input type="checkbox"/> 2500-3000	9	3/0-500MCM		X	CU
<input type="checkbox"/> 2500-3000	12	3/0-400MCM		X	CU
<input type="checkbox"/> 4000	16	4/0-500MCM	X		CU/AL
<input type="checkbox"/> 4000	12	3/0-400MCM		X	CU/AL
<input type="checkbox"/> 4000	12	500-750MCM		X	CU/AL
<input type="checkbox"/> 4000	12	3/0-500MCM		X	CU
<input type="checkbox"/> 4000	16	3/0-700MCM		X	CU

H



Transfer Switch Equipment

30 through 4000A

Open Panel and Basic Panel Switch Dimensions

- Power Panel 30-100 Amperes 2, 3, 4 Poles
Automatic - Electromechanical and Solid State Logic Switches
Non-Automatic and Basic Switches

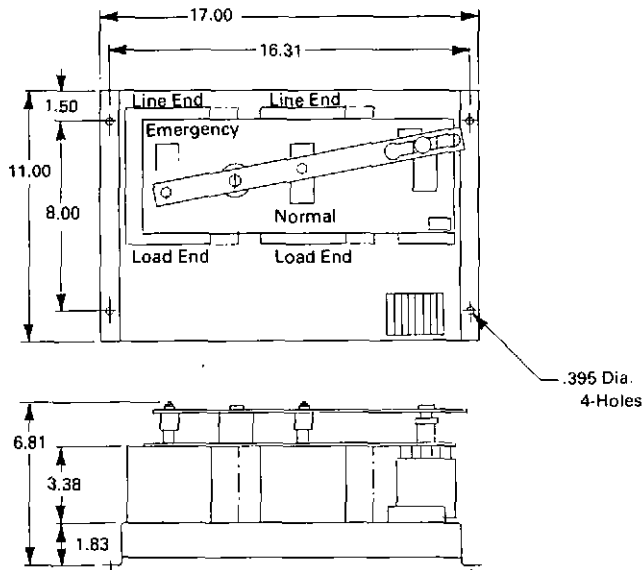

Approximate Shipping Weight - 30 lbs.

See DS 29-970, Page 3, for Logic Panel Dimensions

- Power Panel 30-100 Amperes 2, 3, 4 Poles
Manual - Single and Dual Handle Operated Switches

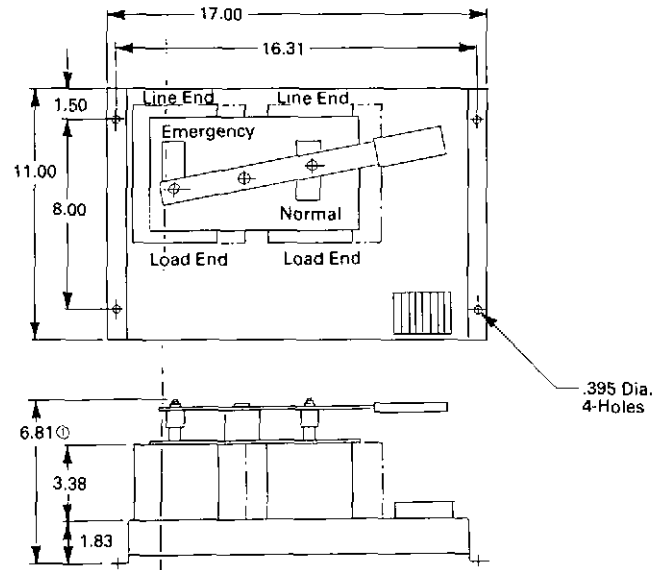

Ⓢ Dual Handle Unit - Single Handle Mechanism is omitted
Depth Dimension becomes 5.62

Approximate Shipping Weight - 25 lbs.

- Power Panel 150-1000 Amperes 2, 3, 4 Poles
Automatic-Electromechanical and Solid State Logic Switches
Non-Automatic, Basic, & Single Handle Operation Manual Switches

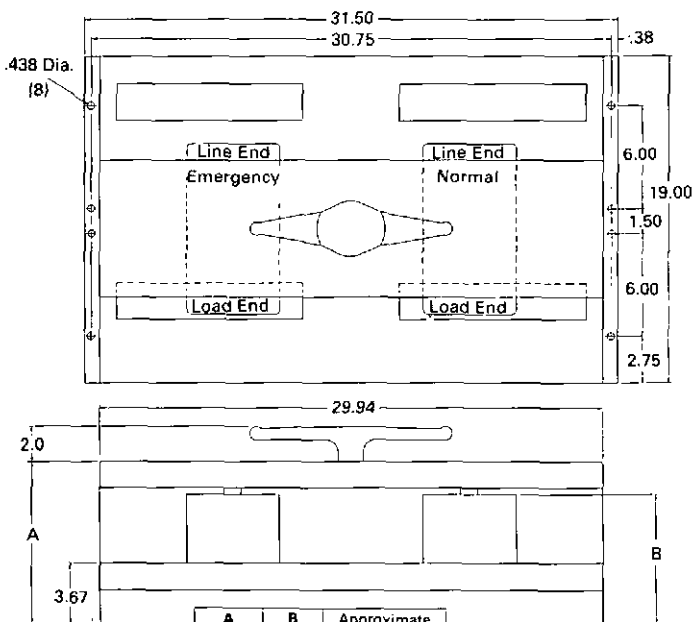

	A	B	Approximate Shipping Weight (lbs)
□ 150-280 AMP	10.75	7.74	225
□ 400 AMP	11.22	7.74	250
□ 600 AMP	11.84	7.74	275
□ 800-1000 AMP	12.96	9.17	325

See DS 29-970, Page 3, for Logic Panel Dimensions

- Power Panel 150-1000 Amperes 2, 3, 4 Poles
Dual Handle Operated Manual Switches

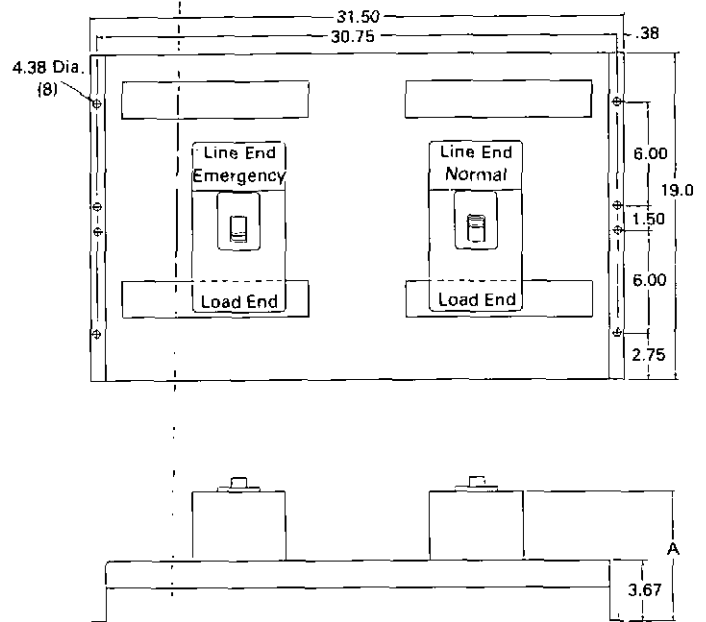

	A	Approximate Shipping Weight (lbs)
□ 150-600 AMP	7.74	250
□ 800-1000 AMP	9.17	300

H



Transfer Switch Equipment 30 through 4000A

Systems Pow-R Breaker Type Switches

1200-2000 Amperes, 3, 4 Pole, Open - Rear Bus Connected

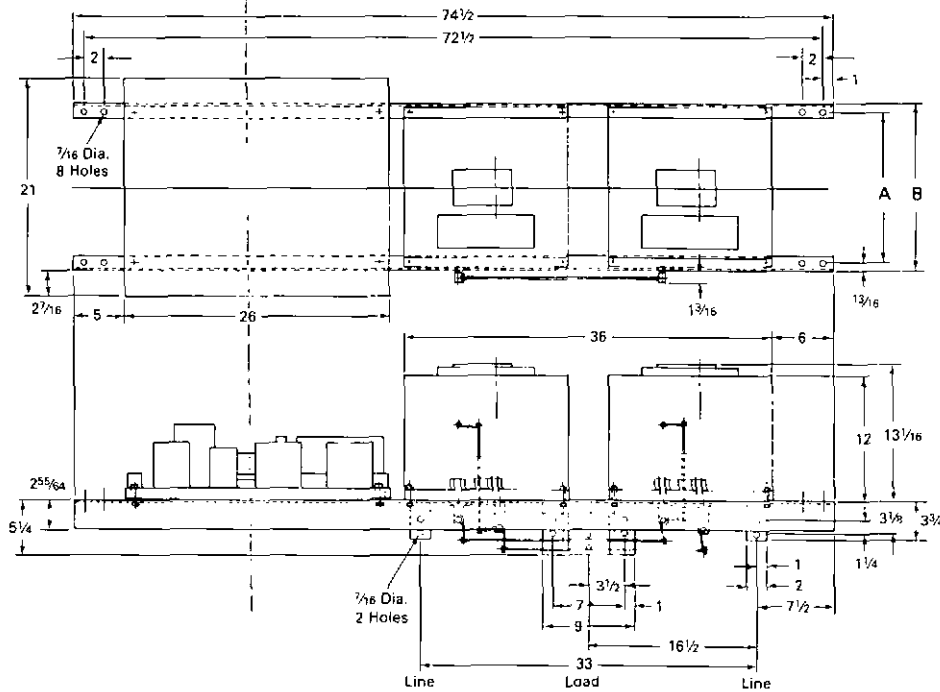

	A	B	Approximate Shipping Weight (lbs)
<input type="checkbox"/> 3 Pole	14 1/2	16 1/8	700
<input type="checkbox"/> 4 Pole	19	20 1/2	775

Systems Pow-R Breaker Type Switches

1200-2000 Amperes, 3 Pole, Open-Customer Bus Connections

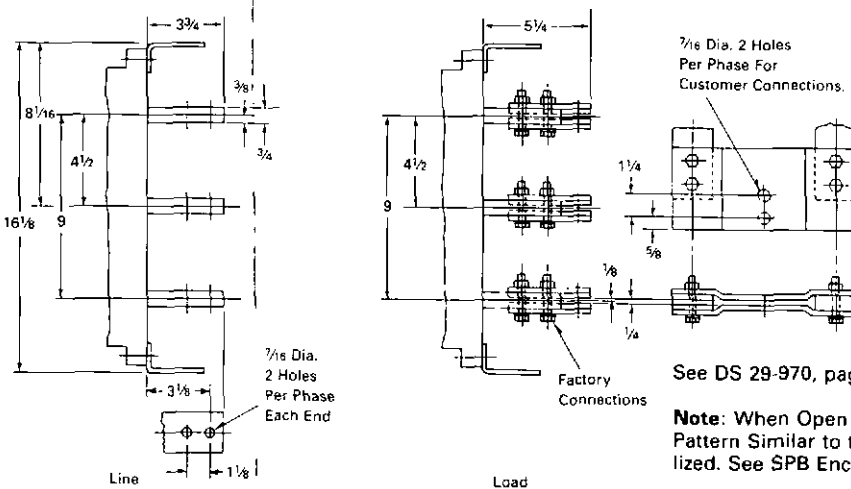

See DS 29-970, page 6, for logic panel dimensions.

Note: When Open Switch is Mounted in Customer Enclosure, a Vent Pattern Similar to that used on Westinghouse Enclosure must be utilized. See SPB Enclosure Drawing 1368D63.

Note: On 4 Pole Units the Bus Connection Pattern and spacing will be duplicated with 4th pole addition.

Figure 1 Reproduced From Drawing 1375D52





Transfer Switch Equipment

30 through 4000A

Systems Pow-R Breaker Type Switches

2500-3000 Amperes, 3, 4 Pole, Open - Rear Bus Connected
4000 Amperes, 3 Pole, Open - Rear Bus Connected

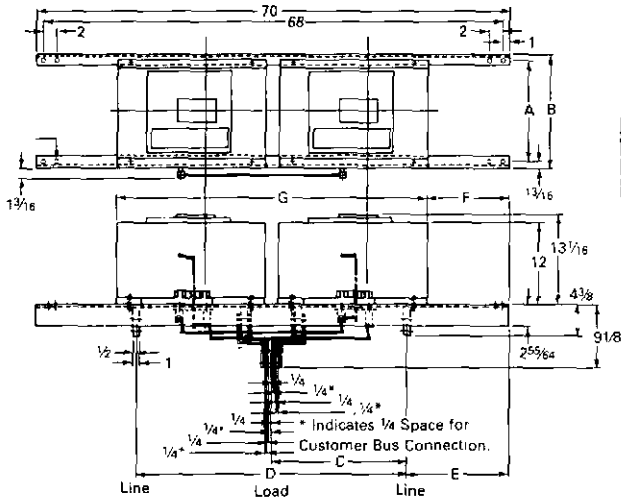

Switch Amp Rating	Pole	Dimensions, Inches							Approximate Shipping Weight (lbs)
		A	B	C	D	E	F	G	
2500	3	14 1/4	16 1/8	20	40	15	12	46	1200
3000	3	14 1/2	16 1/8	20	40	15	12	46	1200
4000	3	25	26 5/8	24	48	11	7 3/4	54 1/2	1400
2500-3000	4	19	20 1/2	20	40	15	12	46	1300

Note: On 4 pole units the bus connection pattern and spacing will be duplicated with 4th pole addition.

2500-3000 Amperes, 3 Pole, Open - Customer Bus Connections

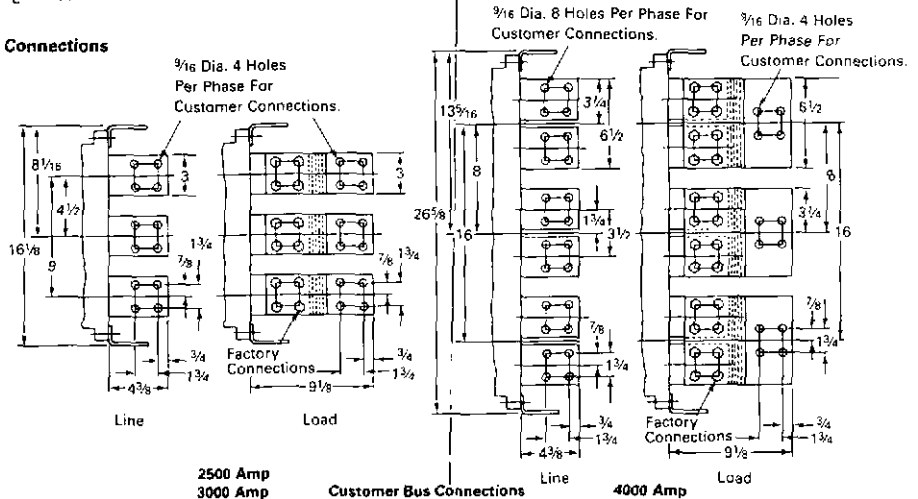

Figure 1 Reproduced From Drawing 1375D51

Drilling Plans for Pilot Devices when Automatic Switch Supplied Open (No Enclosure)

Fig.	Option Description
A	6A, 6C, 8A, 8B, 9A, 11B, 11C, 12A, 12B, 12E, 12F, 12J, 12K, 7C (light), 29B, 29C, 29F, 29H 7C (Selector Switch), 10A, 10C, 23G (Selector Switch)
B	18E (Meter), 18F (Meter), 18G, 18H
C	18E (Selector Switch), 18F (Selector Switch)

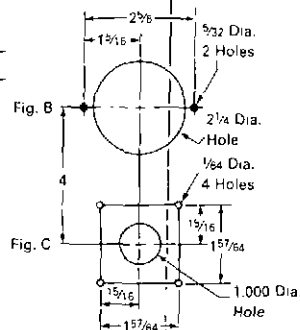
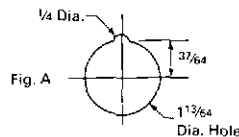

Figure 2 Reproduced From Drawings 1370D19, 751B655



Transfer Switch Equipment 30 through 4000A

WESTINGHOUSE ELECTRIC CORPORATION AUTOMATIC TRANSFER SWITCH GUIDE SPECIFICATION

1.0 GENERAL

1.1 Furnish and install where indicated Transfer Switches having the ratings, features/accessories, enclosures, etc. indicated on the drawings or noted herein. The Transfer Switches shall be fully rated to protect all types of loads, inductive and resistive, from loss of continuity of power, without derating, either open or enclosed.

1.2 Material and equipment shall be a standard product of a manufacturer regularly engaged in the manufacture of Transfer Switches and shall essentially duplicate product that has been in satisfactory use for a period of no less than five years prior to the scheduled installation date. The experience shall include applications of equipment and materials of the same design and/or rating as the Transfer Switches specified.

1.3 Transfer Switches and Features/Accessories shall be as manufactured by Westinghouse Electric Corporation.

2.0 REFERENCE STANDARDS

2.1 The latest revision of Standards listed below form a part of this Specification as engineering references where applicable.

2.1.1 Institute of Electrical and Electronics Engineers (IEEE) Publication and/or Standard

- a. 241 Recommended Practice for Electric Power Systems in Commercial Buildings
- b. 446 Recommended Practice for Emergency and Standby Power Systems
- c. 472 Surge Withstand Capability (SWC) Tests

2.1.2 National Electrical Manufacturers Association (NEMA) Publication and/or Standard

- a. ICS Industrial Controls and Systems

2.1.3 Electrical Generating Systems Association (EGSA) Publication and/or Standard

- a. 100-S Performance Standard for Transfer Switches For Use With Engine Generator Sets
- b. 101-E Glossary of Standard Industry Terminology and Definitions - Electrical
- c. 101-M Glossary of Standard Industry Terminology and Definitions - Mechanical

2.1.4 National Fire Protection Association (NFPA) Publication and/or Standard

- a. 20 Centrifugal Fire Pumps
- b. 70 National Electric Code
- c. 99 Health Care Facilities
- d. 110 Emergency Power Supplies

2.1.5 Underwriters' Laboratories, Inc. Publication and/or Standard

- a. 50 Cabinets and Boxes
- b. 489 Molded Case Circuit Breakers
- c. 508 Industrial Control Systems
- d. 1008 Transfer Switches
- e. 1087 Molded Case Switches

3.0 SUBMITTALS

3.1 A complete list of equipment and materials proposed, with an adequate description of each item to be furnished, shall be submitted prior to approval.

3.2 A typical schematic diagram shall be furnished showing normal operation of the Transfer Switch. As built point-to-point wiring schematics must be attached to the inside of the enclosure door in a weather-proof pouch for use by operating and maintenance personnel.

3.3 A certificate of compliance to UL 1008 must be submitted for the Transfer Switches to be supplied. The certificate is not required if the manufacturer's published data submitted and approved reflect a UL 1008 listing. Proof of UL 1008 listing does not, however, relieve the contractor of compliance with other provisions of this specification.

3.4 A test report and Operations and Instructions Manual shall be included with the point-to-point wiring schematic shipped with each Transfer Switch supplied. It shall include results from factory functional testing on the identical unit and shall show each Feature/Accessory as being tested satisfactorily in accordance with the requirements of this specification. The test report shall indicate the manufacturer's Shop Order Number and Serial Number of each Transfer Switch supplied.

4.0 RATINGS

4.1 The Transfer Switches specified herein shall be 100% equipment rated for continuous duty as shown on the drawings and shall conform to the applicable requirements of UL 1008 for emergency total system load. All Transfer Switches supplied shall bear the UL label. All 3 phase 4 wire Transfer Switches used with ground fault equipment shall be the true 4 pole switched neutral type with all four poles for each source being fully rated and connected to a common shaft. Overlapping neutral shall not be acceptable.

4.2 The Transfer Switch shall be rated for non-welding of contacts when used with the upstream overcurrent devices shown on the plans and with the available fault current specified herein.

4.3 The withstand and closing current ratings of the Transfer Switch shall be no less than those required to be compatible with the available system short circuit current and the type and rating of systems protective devices.

4.4 The voltage rating of the Transfer Switch shall be no less than the system voltage rating.

4.5 The continuous current rating of the Transfer Switch shall be no less than the maximum continuous current requirements of the system.

4.6 All pilot devices and relays shall be of the industrial type rated 10 amperes with self-cleaning contacts.



Transfer Switch Equipment 30 through 4000A

5.0 CONSTRUCTION

5.1 Transfer Switches specified herein shall consist of completely enclosed contact assemblies and a separate control logic panel. The contact assemblies shall be operated by a non-fused motor operator or stored energy mechanism, and be energized only momentarily during transfer providing inherently double throw switching action. Control power for all transfer operations shall be derived from the line side of the source to which the load is being transferred.

5.2 Transfer Switches shall be capable of being operated manually under full load conditions and shall be equipped with a permanently affixed manual operator designed to prevent injury to operating personnel in the event that the electrical operator should suddenly become energized during transfer. In addition, provisions should be provided to allow disengagement of the electrical operator during manual operation. The manual operator shall provide the same contact-to-contact transfer time as provided under normal automatic operation to prevent possible flashovers from switching the main contacts slowly.

5.3 Each Transfer Switch shall be positively interlocked mechanically and electrically to prevent simultaneous closing of both sources under either automatic or manual operation. Main contacts shall be mechanically locked in position in both Normal and emergency positions. A neutral position shall not be possible under normal electrical operation unless a Delayed Transition accessory is required for switching highly inductive loads. Each Transfer Switch shall have a manual neutral position for load circuit maintenance. A Transfer Switch position indicator shall be visible from the front of the switch to show to which source the Transfer Switch is connected.

5.4 Inspection and replacement of all separate arcing contacts (moving and stationary) shall be possible from the front of the Transfer Switch.

5.5 A solid state sensing and control logic panel shall be separately mounted from the power switching portion of the Transfer Switch. The two sections shall be connected together by control cables with plug in connectors. The control section shall be capable of being disconnected from the power section for maintenance purposes.

5.6 The logic circuit shall utilize solid state components mounted on printed circuit boards to accomplish proper operation, wherever practical, to accomplish functions such as timing, voltage and frequency monitoring. LED's shall be furnished to indicate the operation of each function furnished. Construction shall be such that functions are individually replaceable without requiring replacement of the complete solid state package. Plug-in modifications shall be available for field installation with retention of the UL label.

5.7 The Transfer Switch shall be equipped with a voltage selection plug making it suitable for operation on any voltage from 208 through 600 volts AC, 50 or 60 Hertz, by placing the voltage selection plug in the proper voltage receptacle. Covers shall be used to block off the unused receptacles.

5.8 Each Transfer Switch shall be supplied in the appropriate enclosure as shown on the plans. The enclosure shall be painted with the manufacturer's standard painting procedures to insure suitability for environmental conditions as referenced in the plans. The contractor's field wiring terminating within the enclosure shall comply with NFPA 70. If wiring is not color coded, wires shall be permanently marked near the terminal at each end with the wire number shown on the approved shop drawings. Terminal blocks shall conform to NEMA ICS 4. Terminal facilities shall be arranged for entrance of external conductors from the top or bottom of the enclosure. Main Transfer Switch terminals shall be suitable for the termination of conductors shown on the plans.

6.0 SEQUENCE OF OPERATION

6.1 Upon loss of phase-to-phase voltage of the normal source to 70% of nominal, and after a time delay of .5 - 15 seconds (adjustable to meet conditions present) to override momentary dips and/or outages, a 10 ampere, 30VDC contact shall close to initiate starting of the Emergency/Standby Source power plant. Transfer to the Alternate Source shall take place immediately upon attainment of 90% of rated voltage and frequency of that source. For switches not involving engine generator sets as power plants, transfer shall occur after an adjustable time delay of 1- 60 seconds to override momentary dips and outages.

6.2 When the Normal Source has been restored to 90% of rated voltage, and after a time delay adjustable from .2 - 30 minutes (to insure the integrity of the Normal Power Source), the load shall be retransferred to the Normal Source.

6.3 A time delay, adjustable .2 - 30 minutes, shall delay shutdown of the Emergency/Standby Power Source after retransfer to allow the generator to run unloaded for cool-down, after which the generator shall be automatically shut down.

6.4 If the Emergency/Standby power plant should fail while carrying the load, transfer to the Normal Power supply shall be made instantaneously upon restoration of the Normal Source to satisfactory conditions.

7.0 FEATURES/ACCESSORIES

The following Features/Accessories shall be supplied as indicated:

7.1.a _____ Auto/Test Switch to provide test operation of the Transfer Switch by simulating a loss of the Normal Power Source, or

7.1.b _____ Four Position Switch permitting four modes of Transfer Switch operation: "TEST" (simulates Normal Power outage), "AUTO" (standard automatic operation), "OFF" (de-energizes control relays and opens the engine start circuit for maintenance purposes), "ENGINE START" (retains Transfer Switch in Normal position and initiates a testing of the engine start circuit).

Note: Either the Test Switch or Four Position Selector Switch MUST be supplied to comply with UL 1008 requirements for Automatic Transfer Switches.

7.2 _____ Pilot lights to indicate to which source the load is connected.

7.3 _____ Pilot lights to indicate presence of voltage at the line side of each source.

7.4 _____ Relay/auxiliary contacts (2 N/O, 2 N/C) to indicate Transfer Switch position and integrity of each source.

7.5 _____ Plant Exerciser Timer providing automatic test operation of the Emergency/Standby Power Source at pre-selected intervals (Adj. 0 - 168 hrs. in multiples of 15 minutes) at least once per week. Available for Exercise: (___ without interruption of Normal Power Supply), (___ by simulation of Normal Power failure, thus transferring the load to the Emergency/Standby Source), (___ with selector switch for choosing exercise with load transfer, without load transfer, or for bypassing the exercise period).



Transfer Switch Equipment 30 through 4000A

- 7.6 _____ Delayed Transition position (adjustable 0 - 120 seconds) to allow disconnection of the load during transfer in either direction to prevent excessive inrush currents due to out-of-phase switching of large inductive loads.
- 7.7 _____ Pre-transfer Signal Devices with 2 N/O, 2 N/C contacts that open/close on a timed basis (adjustable 0 - 120 seconds) to allow the load to be de-energized prior to transfer in either direction. (Typically used in conjunction with elevator controls.)
- 7.8 _____ Preferred Source Selector Switch permitting selection of either source as the preferred source to which the Transfer Switch will always transfer if that source is available.
- 7.9 _____ Bypass pushbuttons for time delay on transfer and retransfer to be used during testing when it is not desirable to wait for timers to finish their timing sequence before transferring.
- 7.10 _____ Cranking Limiter (adjustable 4 - 120 seconds) that interrupts the engine start circuit if voltage does not appear within a preselected time.
- 7.11 _____ Extender Cable to permit remote mounting of intelligence circuitry to accommodate limited space requirements. Length required is (_ 2, _ 4, _ 6, _ 8, _ 10) feet.
- 7.12 _____ Overcurrent protection and tripped position indicating light for the (_ Normal Source) (Emergency/Standby Source).
- 7.13 _____ Shunt trip on the (_ Normal Source) (_ Emergency/ Standby Source) wired to terminal blocks for ease of contractor connection. Coil voltage required ____.
- 7.14 _____ UL listing as "Suitable for use as Service Equipment." (Selection of this feature requires overcurrent protection on both sources for UL listing. Ground Fault Protection is required on systems rated above 1000 amperes with systems voltages of greater than 150 volts to ground.)
- 7.15 _____ Pushbutton retransfer from the Emergency/Standby Source to the Normal Source. This feature provides automatic operation Normal to Emergency and also includes an immediate automatic retransfer to the Normal Source (if available) upon failure of the Emergency/Standby Source.
- 7.16 _____ Automatic/Manual Operation Switch which permits selection of automatic or manual operation of the Transfer Switch. (Note: This option is not covered under UL 1008; thus, if included, the Transfer Switch will not bear the UL Label.)
- 7.17 _____ Hand held test kit for field testing and calibration of all plug-in timing and monitoring logic cards, as well as the output relays from the solid state logic panel.

8.0 INSTALLATION

- 8.1 Installation of all Transfer Switches specified herein shall be in accordance with all applicable codes, standards, and practices.
- 8.2 Installation of all Transfer Switches specified herein shall be in accordance with the recommendations of the manufacturer.

WESTINGHOUSE ELECTRIC CORPORATION MANUAL TRANSFER SWITCH

1.0 GENERAL

- 1.1 Furnish and install where indicated Transfer Switches having the Ratings, Feature/Accessories, Enclosures, etc. indicated on the drawings or noted herein.
- 1.2 Transfer Switches and Features/Accessories shall be Single Handle Manual Type as manufactured by Westinghouse Electric Corporation, or approved equal.

2.0 RATINGS

- 2.1 The Transfer Switches specified herein shall be 100% equipment rated for continuous duty as shown on the drawings and shall conform to the applicable requirements of UL 1008 for emergency total system load. All Transfer Switches supplied shall bear the UL label. All 3 phase 4 wire Transfer Switches used with ground fault equipment shall be the true 4 pole switched neutral type with all four poles for each source being fully rated and connected to a common shaft.
- 2.2 The Transfer Switch shall be rated for non-welding of contacts with the available fault current specified herein.

2.3 The Interrupting current ratings of the Transfer Switch shall be no less than those required to be compatible with the available system short circuit current. To insure the integrity of the system, Transfer Switches whose interrupting rating is not equal to or greater than their withstand rating will not be approved under this specification.

2.4 All Transfer Switches shall be rated for operation at all voltages up to and including 600VAC.

3.0 CONSTRUCTION

- 3.1 Transfer Switches specified herein shall consist of completely enclosed contact assemblies. The contact assemblies shall be equipped with a single operating handle in an arrangement to provide inherently double throw switching action.
- 3.2 Transfer Switches shall be capable of being operated manually under full load conditions. The manual operator shall provide true quick-make, quick-break operation to prevent possible flashovers from switching the contacts slowly.
- 3.3 Each Transfer Switch shall be positively interlocked via means of the operating mechanism, and shall also be equipped with a Walking Beam Interlock to prevent simultaneous closing of both sources during manual operation. Each Transfer Switch shall be capable of achieving a neutral position for systems maintenance purposes. A position indicator shall be included on the face of the transfer mechanism to display the switch position.



Transfer Switch Equipment 30 through 4000A

3.4 Main contacts shall be designed to withstand multiple fault currents, and shall meet UL 489 and or UL 1087 requirements.

3.5 Each Transfer Switch shall be supplied in an appropriate enclosure as shown on the plans. The enclosure constructed of galvanized steel and shall be painted with the manufacturer's standard painting procedures to insure suitability for environmental conditions. The contractor's field wiring terminating within the Enclosure shall comply with NFPA 70. If wiring is not color coded, wires shall be permanently marked near each end with the wire number shown on the approved shop drawings. Terminal blocks shall conform to NEMA ICS 4. Main Transfer Switch terminals shall be suitable for the termination of conductors shown on the plans.

4.0 FEATURES/ACCESSORIES

The following Features/Accessories shall be supplied as indicated:

4.1 Main contact assemblies shall be equipped with Thermal Magnetic Trip Units and AB De-ion Arc Extinguishers. Trip units shall have adjustable Magnetic trip values for each pole. Tripping mechanisms shall be designed "Trip Free" so that the contacts cannot be held closed against an abnormal circuit condition.

4.2 Auxiliary contacts (2 N/O, 2 N/C) for each source to indicate Transfer Switch position.

4.3 Pilot Lights to indicate source position and/or availability of voltage.

5.0 INSTALLATION

5.1 Installation of all Transfer Switches specified herein shall be in accordance with all applicable codes, standards, and practices.

5.2 Installation of all Transfer Switches specified herein shall be in accordance with the recommendations of the manufacturer.

WESTINGHOUSE ELECTRIC CORPORATION NON-AUTOMATIC TRANSFER SWITCH SPECIFICATION

1.0 GENERAL

1.1 Furnish and install where indicated Transfer Switches having the Ratings, Features/Accessories, Enclosures, etc. indicated on the drawings or noted herein.

1.2 Transfer Switches and Features/Accessories shall be Electrically Operated Non-Automatic Type as manufactured by Westinghouse Electric Corporation.

2.0 RATINGS

2.1 The Transfer Switches specified herein shall be 100% equipment rated for continuous duty as shown on the drawings and shall conform to the applicable requirements of UL 1008 for emergency total system load. All Transfer Switches supplied shall bear the UL Label. All 3 phase 4 wire Transfer Switches used with ground fault equipment shall be the true 4 pole switched neutral type with all four poles for each source being fully rated and mounted on a common shaft. Add-on, bolt-on or overlapping neutrals are not acceptable for 4 pole applications.

2.2 The Transfer Switch shall be rated for non-welding of contacts with the available fault current specified herein.

2.3 The interrupting current ratings of the Transfer Switch shall be no less than those required to be compatible with the available system short circuit current. To insure the integrity of the system, Transfer Switches whose interrupting rating is not equal to or greater than their withstand rating will not be approved under this specification.

2.4 All Transfer Switches shall be UL 1008 Listed and rated for operation at all voltages up to and including 600VAC.

3.0 CONSTRUCTION

3.1 Transfer Switches specified herein shall consist of completely enclosed contact assemblies and a separately mounted control/accessory panel. The contact assemblies shall be operated by a non-fused unidirectional motor operator or stored energy mechanisms, and be energized only momentarily during transfer. Control power for all transfer operations shall be derived from the line side of the source to which the load is being transferred.

3.2 Transfer Switch operation shall be manually initiated, electrical operation accomplished via pushbuttons mounted on the enclosure door. Transfer Switches shall be capable of being operated electrically or manually under full load conditions. The manual operator shall provide true quick-make, quick-break operation to prevent possible flashovers from switching the contacts slowly.

3.3 Each Transfer Switch shall be positively mechanically interlocked to prevent simultaneous closing of both sources during manual operation. A neutral (both sources off) condition shall not be possible under normal electrical operation; however, Transfer Switches shall be capable of achieving a manual neutral position for systems maintenance purposes. A position indicator shall be included on the face of the transfer mechanism to display the switch position.

3.4 Main contacts shall be designed to withstand multiple fault currents, and shall meet or exceed UL 1087 requirements for short circuit and endurance testing.

3.5 Each Transfer Switch shall be supplied in an appropriate enclosure as shown on the plans. The enclosure shall be painted with the manufacturer's standard painting procedures to insure suitability for environmental conditions. The contractor's field wiring terminating within the Enclosure shall comply with NFPA 70. If wiring is not color coded, wires shall be permanently marked near each end with the wire number shown on the approved shop drawings. Terminal blocks shall conform to NEMA ICS 4. Main Transfer Switch terminals shall be suitable for the termination of conductors shown on the plans.



Transfer Switch Equipment 30 through 4000A

4.0 FEATURES/ACCESSORIES

- 4.1 Provide auxiliary relay contacts (3 N/O, 3 N/C) for each source for customer use.
- 4.2 Provide a Red Pilot Light to indicate the transfer switch is closed in the emergency position, and a Green Pilot Light to indicate the switch is closed in the normal position.

WESTINGHOUSE ELECTRIC CORPORATION COMBINATION TRANSFER SWITCH AND BYPASS ISOLATION SWITCH TYPICAL SPECIFICATION (100 - 1000 AMPERES)

1.0 GENERAL

- 1.1 Furnish and install where indicated Combination Automatic Transfer and Bypass Isolation Switches having the Ratings, Features/Accessories, Enclosures, etc. indicated on the drawings or noted herein.
- 1.2 Combination Automatic Transfer and Bypass Isolation Switches and their associated Features/Accessories shall be Type ATSB1 as manufactured by Westinghouse Electric Corporation.

2.0 RATINGS

- 2.1 The Transfer Switch Equipment as specified herein shall be 100% equipment rated for continuous duty as shown on the drawings and shall conform to the applicable requirements of UL 1008 for emergency total system load. All Transfer Switch Equipment supplied shall bear the UL label. All 3 phase 4 wire Transfer Switch equipment used with ground fault equipment shall be the true 4 pole switched neutral type with all four poles for each source being fully rated and connected to a common shaft. The fourth (Neutral) pole contacts shall be of identical construction as, and operate simultaneously with, the main power contacts. Add-on or overlapping neutral contacts shall not be acceptable under this specification.
- 2.2 The Transfer Switch Equipment shall be rated for non-welding of contacts when used with the upstream overcurrent devices shown on the plans and with the available fault current specified herein.
- 2.3 The withstand, closing and interrupting ratings of the Transfer Switch Equipment shall be no less than those required to be compatible with the available system short circuit current and the type and rating of systems protective devices.
- 2.4 All main power contacts shall be rated for multiple fault interruptions per UL 1087. On 4 pole equipment, the Neutral pole shall have identical withstand, closing, and interrupting ratings as the main power contacts.

5.0 INSTALLATION

- 5.1 Installation of all Transfer Switches specified herein shall be in accordance with all applicable codes, standards, and practices.
- 5.2 Installation of all Transfer Switches specified herein shall be in accordance with the recommendations of the manufacturer.

3.0 CONSTRUCTION

- 3.1 Automatic Transfer Switches specified herein shall consist of completely enclosed contact assemblies and a separate control logic panel. The contact assemblies shall be operated by a non-fused unidirectional gear motor and be energized only momentarily during transfer providing inherently double-throw switching action. Control power for all automatic transfer operations shall be derived from the line side of the source to which the load is being transferred.
- 3.2 Automatic Transfer Switches shall be capable of being operated manually under full load conditions and shall be equipped with a *permanently affixed manual operator designed to prevent injury to operating personnel in the event that the electrical operator should suddenly become energized during transfer.* The manual operator shall provide the same contact-to-contact transfer as provided under normal automatic operation to prevent possible flashovers from switching the main power contacts slowly. It shall provide true quick-break, quick-make manual operation. In addition, a motor disconnect plug shall be provided to allow disengagement of the electrical operator during manual operation.
- 3.3 Each Automatic Transfer Switch shall be positively interlocked mechanically and electrically to prevent simultaneous closing of both sources under either automatic or manual operation. A neutral position shall not be possible under normal electrical operation unless a Delayed Transition Timer is required for switching highly inductive loads. Each Automatic Transfer Switch shall have a manual neutral position for load circuit maintenance. Indicating lights shall be provided on the enclosure door to show the status of main power contacts for each source. In addition, a position indicator shall be visible from the front of the switch to show to which source the load is connected.
- 3.4 Inspection and replacement of all separate arcing contact assemblies (moving and stationary) shall be possible from the front of the switch.
- 3.5 A solid state sensing and control logic panel shall be separately mounted from the power switching portion of the Transfer Switch. The two sections shall be connected together by control cables with keyed plug-in connectors. The control section shall be capable of being disconnected from the power section for maintenance purposes. On switches above 100 amperes, the control panel shall be provided on drawout rails for ease of maintenance and testing.
- 3.6 The logic circuit shall utilize solid state components mounted on printed circuit boards to accomplish proper operation, wherever practical, to perform functions such as timing and close differential voltage and frequency monitoring. LED's shall be furnished to indicate the operation of each function furnished. Construction shall be modular such that functions are individually replaceable without requiring removal or replacement of the complete solid state package. Plug-in modifications shall be available for field installation with retention of the UL label.



Transfer Switch Equipment

30 through 4000A

3.7 The Transfer Switch shall be equipped with a voltage selection plug making it suitable for operation on any systems voltage from 208 through 600 VAC, 50 or 60 Hertz, by placing the voltage selection plug in the proper receptacle. Covers shall be provided to block off the unused receptacles.

3.8 Each Automatic Transfer Switch and its associated Bypass Isolation Switch shall be supplied in a single Type 1 Enclosure. The enclosure shall be painted with the manufacturer's standard painting procedures to insure suitability for environmental conditions as referenced in the plans. The contractor's field wiring terminating within the enclosure shall comply with NFPA 70. If wiring is not color coded, wires shall be permanently marked near the terminal at each end with the wire number shown on the approved shop drawings. Terminal blocks shall be suitable for the termination of conductors as shown on the plans.

4.0 SEQUENCE OF OPERATION

4.1 Upon loss of phase-to-phase voltage of the Normal Power Source on any phase to 70% of nominal, and after a time delay of .5 to 15 seconds (adjustable to meet conditions present) to override momentary dips and/or outages, a 10 ampere, 30 VDC contact shall close to initiate starting of the Emergency/Standby Power Source. Transfer to the Emergency/Standby Power Source shall take place immediately upon attainment of 90% of rated voltage and frequency of that source. For switches not involving motor generator sets as power plants, transfer shall occur after an adjustable time delay of 1-60 seconds to override momentary dips and outages.

4.2 When the Normal Power Source has been restored to 90% of rated voltage and after a time delay adjustable from .2-30 minutes (to insure the integrity of the Normal Power Source), the load shall be retransferred to the Normal Source.

4.3 A time delay, adjustable .2 - 30 minutes, shall delay shutdown of the Emergency/Standby Power Source after retransfer to allow the generator to run unloaded for cool-down, after which the generator shall automatically shut down.

4.4 If the Emergency/Standby Power Source should fail while carrying the load, transfer to the Normal Power Source shall be made instantaneously upon restoration of the Normal Source to satisfactory conditions.

5.0 FEATURES/ACCESSORIES

The following Features/Accessories shall be provided:

5.1 Auto/Test Switch to provide test operation of the Automatic Transfer Switch by simulating a loss of the Normal Power Source. The Auto/Test Switch shall allow complete testing of the Automatic Transfer Switch while the Isolating Mechanism of the Bypass Isolation Switch is in the "On" or "Isolated" position.

5.2 Pilot Lights to indicate to which source the load is connected, isolated condition of the transfer switch, bypass switch position, and whether a fault has occurred on the system.

5.3 Relay auxiliary contacts (3N/O, 3 N/C) to indicate Transfer Switch position and integrity of each source.

5.4 Plant Exerciser Timer providing automatic test operation of the Emergency/Standby Power Source at pre-selected intervals (adjustable from 1 minute to 168 hours) at least once per week. The Clock Timer shall be provided with a digital readout and have a lithium battery backup to assure continuity of power.

5.5 Hand held test kit for field testing, maintenance, and calibration of all plug-in timing and monitoring logic cards, as well as the output relays from the solid state logic panel.

BYPASS ISOLATION SWITCH SECTION

6.0 CONSTRUCTION

6.1 Bypass Isolation Switches specified herein shall consist of completely enclosed contact assemblies with Dead Front operation.

6.2 Positive Mechanical Key Interlocks shall be provided for the Bypass and Isolation Switches to prevent simultaneously closing of the Normal and Emergency Power Sources when in the "Bypass" and/or "Isolated" mode. Bypass Isolation Switches utilizing Electrical Interlocking to prevent simultaneous closing of both power sources are not acceptable.

6.3 Operating handles for the Bypass and Isolation Switches shall be externally operable with a maximum of two handles required to bypass and isolate the Automatic Transfer Switch.

6.4 Operating instructions shall be permanently affixed to the outside of the enclosure.

6.5 The Automatic Transfer Switch and Bypass Isolation Switch Sections shall be connected together via copper bus or cable and shall not rely on drawout mechanisms to provide total isolation of the Automatic Transfer Switch.

6.6 All pilot lights shall be industrial grade, oil tight and corrosion resistant.

7.0 SEQUENCE OF OPERATION

7.1 Total Isolation of all line and load connections of the Automatic Transfer Switch shall be performed with the turn of a single handle opening the load-break isolation devices. A key interlock shall then be released locking the switch in the "Isolated position. (Note: The Isolation devices shall meet all rating requirements of the Automatic Transfer Switch and Bypass Switches including full load current ratings, withstand, closing, and interrupting ratings, and mechanical endurance ratings.)

7.2 The Key interlock on the "Normal Bypass" or "Emergency Bypass" shall then be released to allow Bypassing to the appropriate Power Source. Key interlocking shall not allow simultaneous closing of both power sources in the "Bypass" mode, but shall allow for Manual Transfer of the load from one Power Source to the other when necessary.

7.3 Reversal of the above procedures shall allow reconnection of the Automatic Transfer Switch.

8.0 FEATURES/ACCESSORIES

8.1 Key Interlocks shall be provided for Normal Bypass, Emergency Bypass, and the Isolation Mechanism. Only one key shall be provided.

8.2 Pilot Lights shall be provided as follows: White Lights to indicate the availability of Normal Power Source, Emergency Power Source, and Load Power; Red/Green lights to indicate position of the Automatic Transfer Switch; and Amber lights to indicate that a Normal Bypass, Emergency Bypass, or Isolation Switch has automatically opened; and a blue light to indicate that the transfer switch is isolated.



Transfer Switch Equipment 30 through 4000A

9.0 INSTALLATION

9.1 Installation of all Transfer Switch Equipment specified herein shall be in accordance with all applicable codes, standards, and practices.

9.2 Installation of all Transfer Switch Equipment specified herein shall be in accordance with the recommendations of the Manufacturer.

WESTINGHOUSE ELECTRIC CORPORATION TYPICAL SPECIFICATION SERVICE ENTRANCE TRANSFER SWITCH

1.0 GENERAL

1.1 Furnish and install where indicated Automatic Transfer Switch Rated "Suitable for Use as Service Equipment" with Ratings, Features/Accessories, Enclosures, etc. indicated on the drawings or noted herein.

1.2 Service Entrance Rated Automatic Transfer Switches and their associated Features/Accessories shall be as manufactured by Westinghouse Electric Corporation

2.0 RATINGS

2.1 The Transfer Switch Equipment as specified herein shall be 100% equipment rated for continuous duty at the ratings as shown on the plans and shall conform to the applicable requirements for UL 1008 for emergency total system load. All Transfer Switch Equipment supplied shall bear the UL label.

2.2 The Transfer Switch Equipment shall be rated for non-welding of contacts with the available fault current specified herein.

2.3 The minimum withstand, closing and interrupting ratings of the Transfer Switch Equipment shall be no less than those required to be compatible with the available system short circuit current as shown on the plans.

2.4 All main power contacts shall be rated for multiple fault interruptions per UL 489, and/or UL1087.

3.0 CONSTRUCTION

3.1 Service Entrance Rated Automatic Transfer Switches specified herein shall consist of completely enclosed contact assemblies including Thermal Magnetic Integral Overcurrent Protection or RMS current sensing Trip Units rated as shown on the plans, and a separately mounted control logic panel. The contact assemblies shall be operated by a non-fused unidirectional gear motor or stored energy operators and be energized only momentarily during transfer providing inherently double-throw switching action. Control power for all automatic transfer operations shall be derived from the line side of the source to which the load is being transferred.

3.2 Automatic Transfer Switches shall be capable of being operated manually under full load conditions and shall be equipped with a permanently affixed manual operator designed to prevent injury to operating personnel in the event that the electrical operator should suddenly become energized during transfer. The manual operator shall provide the same contact-to-contact transfer time as provided under

normal automatic operation to prevent possible flashovers from switching the main power contacts slowly. That is, it must provide true quick-break, quick-make manual operation. In addition, means shall be provided to allow disengagement of the electrical operator during manual operation.

3.3 Each Automatic Transfer Switch shall be positively interlocked mechanically and electrically to prevent simultaneous closing of both sources under either automatic or manual operation. A neutral position shall not be possible under normal electrical operation unless a Delayed Transition Timer is required for switching highly inductive loads. Each Automatic Transfer Switch shall have a manual neutral position for load circuit maintenance. A position indicator shall be visible from the front of the switch to show to which source the load is connected.

3.4 Inspection and replacement of all separate arcing contact assemblies (moving and stationary) shall be possible from the front of the Switch.

3.5 A solid state close differential sensing and control logic panel shall be separately mounted from the powerswitching portion of the Transfer Switch. The two sections shall be connected together by control cables with keyed plug-in connectors. The control section shall be capable of being disconnected from the power section for maintenance purposes.

3.6 The logic circuit shall utilize solid state components mounted on printed circuit boards to accomplish proper operation, wherever practical, to perform functions such as timing, voltage and frequency monitoring. LED's shall be furnished to indicate the operation of each function furnished. Construction shall be such that functions are individually replaceable without requiring removal or replacement of the complete solid state package. Plug-in modifications shall be available for field installation with retention of the UL label.

3.7 The Service Entrance Rated Automatic Transfer Switch and its associated control logic panel shall be supplied in the appropriate enclosure as shown in the plans. The enclosure shall be painted with the manufacturer's standard painting procedures to insure suitability for environmental conditions as referenced in the plans. The contractor's field wiring terminating within the enclosure shall comply with NFPA 70. Wires shall be permanently marked near the terminal at each end with the wire number shown on the approved shop drawing. Terminal blocks shall be suitable for the termination of conductors as shown on the plans.

3.8 The Transfer Switch shall include provisions for simultaneous disconnection of load circuits from both sources of power via an externally mounted key operated disconnect operator. This service disconnect operator shall be lockable in the disconnect position positively preventing unauthorized reconnection of load circuits. A pilot light shall be mounted on the enclosure door to indicate that the load has been disconnected from both sources of power for maintenance purposes. An instruction label shall be permanently affixed to the front of the switch immediately adjacent to the service disconnect operator



Transfer Switch Equipment

30 through 4000A

identifying the appropriate operating instructions for the service disconnect function. In addition, a 100% rated service disconnect solid neutral assembly shall be provided to allow disconnection of the Normal Power Supply Neutral and the Emergency/Standby Power Supply Neutral during maintenance.

4.0 SEQUENCE OF OPERATION

4.1 Upon loss of phase-to-phase voltage of the Normal Power Source on any phase to 70% of nominal, and after a time delay of .5 - 15 seconds (adjustable to meet conditions present) to override momentary dips and/or outages, a 10 ampere, 30 VDC contact shall close to initiate starting of the Emergency/Standby Power Source. Transfer to the Emergency/Standby Power Source shall take place 1 - 60 seconds (adjustable) after attainment of 90% of rated voltage and frequency of that source.

4.2 When the Normal Power Source has been restored to 90% of rated voltage and after a time delay adjustable from .2- 30 minutes (to insure the integrity of the Normal Power Source), the load shall be retransferred to the Normal Source.

4.3 A time delay, adjustable .2 - 30 minutes, shall delay shutdown of the Emergency/Standby Power Source after retransfer to allow the generator to run unloaded for cool-down, after which the generator shall be automatically shut down.

4.4 If the Emergency/Standby Power Source should fail while carrying the load, transfer to the Normal Power Source shall be made instantaneously upon restoration of the Normal Source to satisfactory conditions.

5.0 FEATURES/ACCESSORIES

The following Features/Accessories shall be provided:

5.1 Auto/Test Switch to provide test operation of the Automatic Transfer Switch by simulating a loss of the Normal Power Source.

5.2 Pilot Lights to indicate to which source the load is connected.

5.3 Pilot Lights to indicate that an Integral Overcurrent Protective Device has tripped.

5.4 Relay auxiliary contacts (3 N/O, 3N/C) to indicate Transfer Switch position and integrity of each source.

5.5 Plant Exerciser Timer providing automatic test operation of the Emergency/Standby Power Source at pre-selected intervals (adjustable from 1 minute to 168 hours) at least once per week, including a selector switch to select Exercise with or without load or a bypass of the Exercise period. The Clock Timer shall be provided with a digital readout and include a lithium battery backup to assure continuity of power to the Clock Timer for a minimum of 72 hours during an outage.

5.6 Portable hand held test unit for field testing, maintenance, and calibration of all plug-in timing and monitoring logic cards, as well as the output relays from the solid state logic panel.

5.7 Integral ground fault sensing and protective trip functions.

6.0 INSTALLATION

6.1 Installation of all Transfer Switch Equipment specified herein shall be in accordance with all applicable codes, standards, and practices.

6.2 Installation of all Transfer Switch Equipment specified herein shall be in accordance with the recommendations of the Manufacturer.



Transfer Switch Equipment 30 through 4000A

This brochure is published solely for information purposes and should not be considered all inclusive. If further information is required, you should consult Westinghouse Electric Corporation.

Sale of product shown in this literature is subject to terms and conditions outlined in appropriate Westinghouse Electric Corporation selling policies or other contractual agreement between the parties. This literature is not intended to and does not enlarge or add to any such contract. The sole source governing the rights and remedies of any purchaser of this equipment is the contract between the purchaser and Westinghouse.

NO WARRANTIES, EXPRESSED OR IMPLIED, INCLUDING WARRANTIES OF FITNESS FOR A PARTICULAR PURPOSE OR MERCHANTABILITY, OR WARRANTIES ARISING FROM COURSE OF DEALING OR USAGE OF TRADE, ARE MADE REGARDING THE INFORMATION, RECOMMENDATIONS AND DESCRIPTIONS CONTAIN HEREIN. In no event will Westinghouse be responsible to the purchaser or user in contract, in tort (including negligence), strict liability or otherwise for any special, indirect, incidental or consequential damage or loss whatsoever, including but not limited to damage or loss of use of equipment, plant or power system, cost of capital, loss of power, additional expenses in the use of existing power facilities, or claims against the purchaser or user by its customers resulting from the use of the information, recommendations and descriptions contained herein.



Westinghouse Electric Corporation
Transfer Switch Department
250 Westinghouse Drive
London, Kentucky 40741